

SM-2020 Series

Full-Featured 5½-Digit
ISA-Bus Digital Multimeters

Functional Description

SM-2020 instruments are 5½-digit multimeters that plug directly into any full-length I/O slot of an ISA-bus compatible PC/XT/AT computer. The instruments deliver the full functionality and performance you'd expect from a high-end benchtop multimeter without the cost and programming complexity of a typical GPIB instrument.

Instead of LCDs or LEDs, knobs and buttons, SM-2020s are operated graphically via the display on your computer screen, using a standard mouse or keyboard for control. The SM-2020 Series instruments feature user-friendly GUI control panels, presenting the familiar look and feel of benchtop multimeters.

SM-2020 users can make extremely low-level measurements simply and quickly, even in notoriously noisy PC environments. There is no longer the need to provide external signal conditioning or execute the difficult low-level programming of analog-to-digital (A/D) converters.

Careful isolation techniques and internal signal conditioning, along with 24-bit A/D technology, deliver uncompromising integrated solutions to a range of users' measurement needs.

The SM-2020 is a full-featured, cost-effective DMM with robust analog measurement capability. The SM-2020CT extends the capabilities of the SM-2020 with an additional set of valuable functions: frequency and period measurement, external hardware trigger, and programmable level trigger.

SM-2020

The SM-2020 employs a state-of-the-art integrating A/D converter in conjunction with onboard digital signal processing to deliver measurement capabilities unparalleled in PC instrumentation.

FEATURES

- DC and AC volts, current, 2-wire, 4-wire, Ω
- 1 μ V to 300VDC
- AC rms 10Hz to 100KHz
- Versatile 5½-digit DMM
- Simple, fast frequency measurement from 2Hz to 300kHz with up to 1mHz resolution
- With external trigger mode, rates of up to 1000 readings/ second
- Built tough, with more than 300V isolation
- CE-approved
- Windows 3.X/95/98/NT/2000 32-bit driver support

APPLICATIONS

- Portable/field test
- General-purpose bench instrumentation
- Automated/production test
- Automatic data logging
- Laboratory automation

Block Diagram

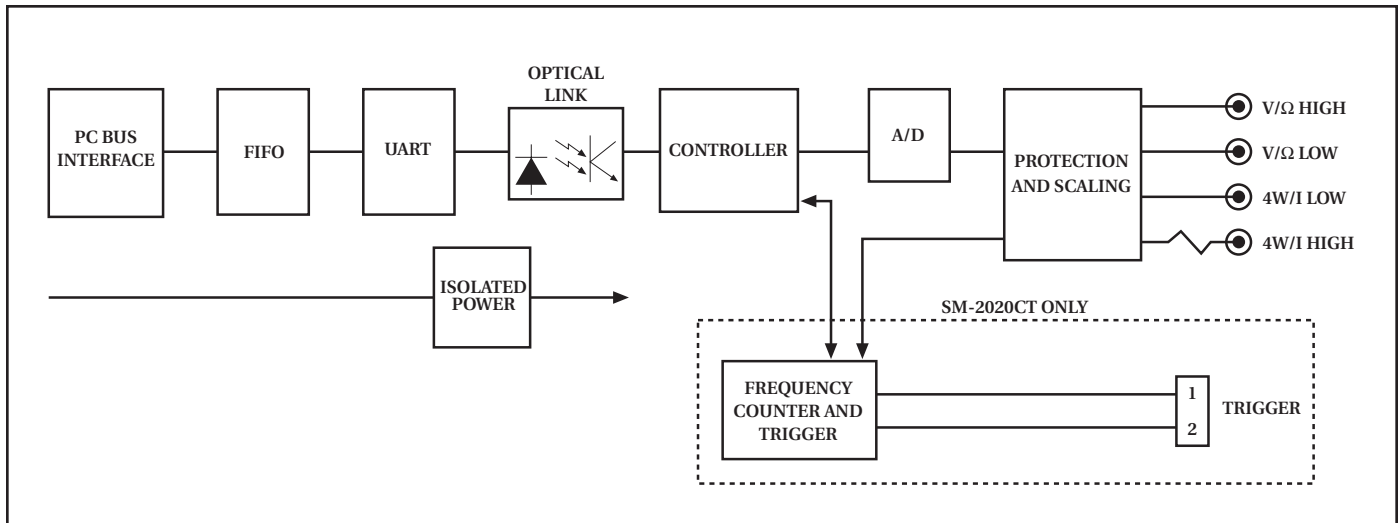

SM-2020 Series

WHY VIRTUAL INSTRUMENTS?

SM-2020 instruments deliver high performance at an impressively low cost, but the advantages of virtual instruments go beyond cash savings.

A significant plus for PC-based instruments is that they plug directly into a PC's bus. External boxes that plug directly into a printer or serial port are useful, but a noteworthy benefit from devices such as the SM-2020 is that they connect to the PC through the ISA bus, removing the requirement for an IEEE-488 interface card, cables, and external power for the instruments.

Enhancements to the capabilities of the basic PC platform have increased the utility of virtual instruments. Computers based on Pentium chips with additional processing bandwidth provide the space needed to create responsive user interfaces that feel like stand-alone instruments.

Virtual instruments are as portable as the computer you plug them into. Portable PCs equipped with SM-2020 or -2020CT boards travel easily to worksites.

Extensive software options are available for SM-2020s making it easy for users to turn data into information. By making information accessible quickly, in terms that can be readily interpreted and applied, virtual instruments optimize time and effort for end-users in a wide variety of applications.

The SM-2020 reliability exceeds that of bench top instruments and exceeds 50,000 hours MTBF in operation.

The SM-2020 has four DC voltage ranges of 300mV, 3V, 30V, and 300V, with outstanding 1 μ V resolution in the lowest range. VAC measurements are made incorporating a true RMS converter, capable of measuring bandwidth from 10Hz to 100kHz. Four VAC ranges are provided, with 1 μ V resolution on the most sensitive range.

The first PC-based DMM to offer 4-wire sensing in ohms, the SM-2020 allows users to make reliable measurements as low as 1m Ω with confidence.

For extraordinary toughness, the SM-2020 is protected to 300V, using MOV and fusible resistor technology found in the most rugged bench and handheld DMMs. An onboard DC-to-DC converter isolates critical analog circuits from the host computer; the PC communicates with the SM-2020 using optically isolated gates.

The high-accuracy, fast-reading SM-2020 has the most full-scale digits (5½) of any PC plug-in DMM readily available. Reading rates are programmed to exactly match the user's application.

Set to the highest resolution reading rate, the SM-2020 delivers precise, highly linear measurements (typically better than 10ppm) and over 80dB of line frequency rejection.

Using the self-calibration function, absolute or relative measurement can be used to null cable parasitic resistance in a system.

SM-2020CT

Offering frequency measurement, period measurement, external hardware trigger and programmable level trigger, the SM-2020CT expands on the functions and specifications of the SM-2020, delivering comprehensive performance from a PC platform.

Frequency measurements can be made in AC voltage and current with 5 digits of resolution. One mHz resolution is provided from 2–100Hz, with an overall measuring bandwidth of 300kHz. From the DOS or Windows control panel, the actual voltage or current is displayed simultaneously with the frequency or period.

The external hardware and programmable level trigger provides a sure means to capture low frequency waveforms, taking advantage of the SM-2020's resolution, high-speed analog-to-digital converter. Users can apply these capabilities in digitizing low-frequency waveforms for seismic studies, stress analysis, sonar, and more.

Reading rates in the external trigger modes are up to 5 times faster than the SM-2020, yielding 1000 readings per second into an onboard buffer.

The external trigger is activated through a hardware signal, or by using the level trigger command. The level trigger allows capture events by means of a user-defined threshold: for example, triggering the DMM if and when voltage exceeds a pre-defined limit.

QUESTIONS?

1-800-552-1115 (U.S. only)

Call toll free for technical assistance, product support or ordering information, or visit our website at www.keithley.com.

SM-2020 Series

Software Support

Keithley SM-2020 Series boards include a Windows-based control panel written in Visual Basic and a DOS-based control panel. Source code for the Windows-based program is provided, enabling you to modify and adapt the panel for your application. DOS drivers for Microsoft/Borland C and Windows 3.x/95/98 drivers are supplied for language-based programming, and can be added directly to your application program. The Series ships with a Windows 3.x/95/98 DLL for use with application software packages such as TestPoint, and with an ActiveX (OCX) control for Windows 95/98 that can be linked to a variety of applications and is a convenient tool for off-line development. Windows NT support is available as an option to support 32-bit applications.

Using the 16- and 32-bit DLLs, the SM-2020 Series can interface to a wide range of application control software, such as LabWindows/CVI and other popular packages.

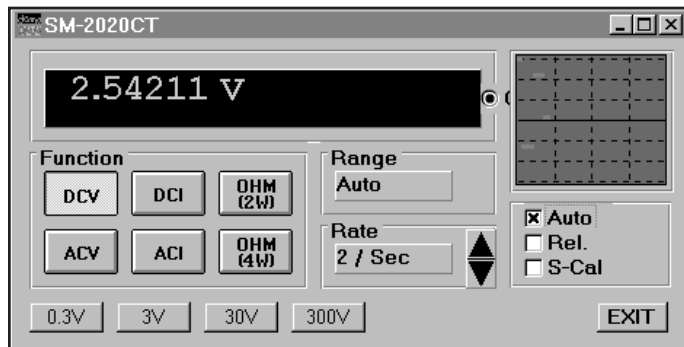

SAMPLE PROGRAM

****This is code showing how a Visual Basic Button is used to select an AC measurement function and take a reading.****

****Click on button to set an ACV Function****

```
Private Sub ACVButton_Click()
    sm2020.MousePointer = 11 'Busy mouse pointer
    ShowFault DMMSetFunction(0, ACVFunc)
    DCVButton.FontBold = False
    ACVButton.FontBold = True
    Ohms2wButton.FontBold = False
    FunctionText.Text = "Volts AC"
    sm2020.MousePointer = 0
End Sub
```

****Updates a display with an AC Voltage reading****

```
Private Sub MeasureTimer_Timer()
    Dim reading As String * 32
    Dim state As Integer
```

```
state = DMMReadingStr(0, reading)
If status = 0 Then
    disp1.Caption = reading
Else
    ShowFault state
End If
End Sub
LF
```

****This is code written in Visual Basic used to read the Frequency and Period using an SM-2020CT****

```
If CounterCheck.Value = True Then
    If DMMFrequencyStr(0, reading) <> 0 Then
        CounterText.Text = "00.000 Hz"
    Else
        CounterText.Text = reading
    End If
End If
If PeriodCheck.Value = True Then
    If DMMPeriodStr(nDmm, reading) <> 0 Then
        CounterText.Text = "00.000 ms"
    Else
        CounterText.Text = reading
    End If
End If
End Sub
```

****Borland C++ example code measuring DC volts**

```
void main(void)
{
    int i;
    double measr;
    system("cls");
    printf("Initializing SM2020 Hardware");
    /* read card type and base address from configuration file dmm.cfg */
    /* and also read Cal file. Initialize structure, Initialize H/W */
    if( (i=InitDmm(0)) != NO_ERR){
        else if(i==ERR_HW_INIT)
            printf("Can't reset H/W, I/O conflict, bad address, or H/W fail.");
        else printf("Fail, can't identify cause.");
        exit(1);
    }
    SetDmmRate(0,DMMRate30); // 30 readings per sec.
                                // VDC 3V Range;
    SetDmmFunction(0,VDC);
    SetDmmRange(0,_3V);
    while( !kbhit() ){ /* measure until key is entered */
        printf("\n");
        measr = ReadDmm(0); // take a reading
        printf("VDC 3V Range:");
        printf(DMMstate[0].prnt_format, (float) measr);
        printf(" %s\n",DMMstate[0].units);
    }
}
```

QUESTIONS ?
1-800-552-1115 (U.S. only)
 Call toll free for technical assistance,
 product support or ordering information, or
 visit our website at www.keithley.com.

SM-2020 Series

SPECIFICATIONS (1 Year Spec)

HARDWARE

RESOLUTION: 5½ digits, ±310,000 counts

MAX READING RATE/SEC: 200 (SM-2020); 1000 (SM-2020CT)

INPUT PROTECTION (ISOLATION): 300VDC, 250VAC from PC Earth ground

DC VOLTAGE

RANGE	RESOLUTION	ACCURACY (one year)*
300mV	1 µV	.024 + 6**
3 V	10 µV	.010 + 4
30 V	100 µV	.022 + 5
300 V	1mV	.018 + 5

AC VOLTAGE, TRUE RMS

RANGE/RESOLUTION	FREQUENCY	ACCURACY (one year)*
[300mV/1 µV]	10 Hz - 20 Hz	2.5 + 400
	20 Hz - 45 Hz	1.0 + 400
	45 Hz - 1 kHz	0.3 + 300
	1 kHz - 10 kHz	0.4 + 350
	10 kHz - 50 kHz	2.0 + 400
[3 V/10 µV 30 V/100 µV 250 V/1 mV]	10 Hz - 20 Hz	2.5 + 300
	20 Hz - 45 Hz	1.0 + 300
	45 Hz - 1 kHz	0.1 + 275
	1 kHz - 10 kHz	0.3 + 275
	10 kHz - 50 kHz	1.0 + 300
	50 kHz - 100 kHz	4.0 + 500

RESISTANCE, 2-WIRE AND 4-WIRE

RANGE	RESOLUTION	ACCURACY (one year)*
3 kΩ	0.001 Ω	0.030 + 6
300 Ω	0.01 Ω	0.029 + 4
30 kΩ	0.1 Ω	0.029 + 5
300 kΩ	1 Ω	0.029 + 5
3MΩ	10 Ω	0.190 + 10
30MΩ	100 Ω	0.650 + 10

DC CURRENT

RANGE	RESOLUTION	ACCURACY (one year)*
3 mA	10 nA	0.070 + 8
30 mA	100 nA	0.090 + 15
300 mA	1 µA	0.090 + 15

AC CURRENT, TRUE RMS

RANGE/RESOLUTION	FREQUENCY	ACCURACY (one year)*
[300 mA/10 nA]	10 Hz - 20 Hz	2.2 + 400
	20 Hz - 45 Hz	0.8 + 400
	45 Hz - 1 kHz	0.7 + 300
	1 kHz - 10 kHz	0.8 + 400
[30 mA/100 nA 300 mA/1 µA]	10 Hz - 20 Hz	2.0 + 300
	20 Hz - 45 Hz	0.8 + 300
	45 Hz - 1 kHz	0.7 + 300
	1 kHz - 10 kHz	0.8 + 400

FREQUENCY MEASUREMENT, FOR AC VOLTAGE INPUT (SM-2020CT ONLY)

FREQUENCY RANGE	RESOLUTION	UNCERTAINTY (% of reading and adder)
2 Hz - 100 Hz	1 mHz	0.01 + 4 mHz
100 Hz - 1 kHz	10 mHz	0.01 + 20 mHz
1 kHz - 10 kHz	100 mHz	0.01 + 200 mHz
10 kHz - 300 kHz	1 Hz	0.01 + 2 Hz

FREQUENCY MEASUREMENT, FOR AC CURRENT INPUT (SM-2020CT ONLY)

FREQUENCY RANGE	RESOLUTION	UNCERTAINTY (% of reading and adder)
100 Hz - 1 kHz	10 mHz	0.01 + 20 mHz
1 kHz - 10 kHz	100 mHz	0.01 + 200 mHz
10 kHz - 30 kHz	1 Hz	0.01 + 2 Hz

* Accuracy is ± (% of reading + Number of counts) To convert "Number of counts" to volts, multiply the "Resolution" by the "Number of counts." For example, the 300 mV Range has 6 counts of error or 6µV. The 300 mV Range accuracy for one year is .024% - 6µV

**Within one hour of DCV zero, using Relative control

ENVIRONMENTAL (BOTH MODELS)

TEMPERATURE RANGE: 0°C to 50°C operating

POWER: +5 volts, 300mA max

EMC: Conforms to European Union Directive 89/336/EEC.

SAFETY: Meets EN61010-1/IEC 1010.

DIMENSIONS: 13.125in L × 4.25in W (one full ISA slot)
(33.4cm L × 10.8cm W)

SOFTWARE

	SM-2020	SM-2020CT
DOS		
Driver:	.lib	.lib
Control Panel:	yes	yes
Windows 3.1/95/NT		
Driver:	.DLL	.DLL
Control Panel:	yes	yes
OCX	yes	yes

ORDER	DESCRIPTION
SM-2020	Full featured 5½-digit DMM
SM-2020CT	Same as SM-2020 with frequency, hardware and triggering
OPTIONS	
SM-2020WNT	Windows NT (V4.0) driver software upgrade

QUESTIONS?

1-800-552-1115 (U.S. only)

Call toll free for technical assistance, product support or ordering information, or visit our website at www.keithley.com.