

Enhancing Trigger Synchronization for High Volume Production Testing of VCSELs with Series 2600B System SourceMeter® Instruments

APPLICATION NOTE

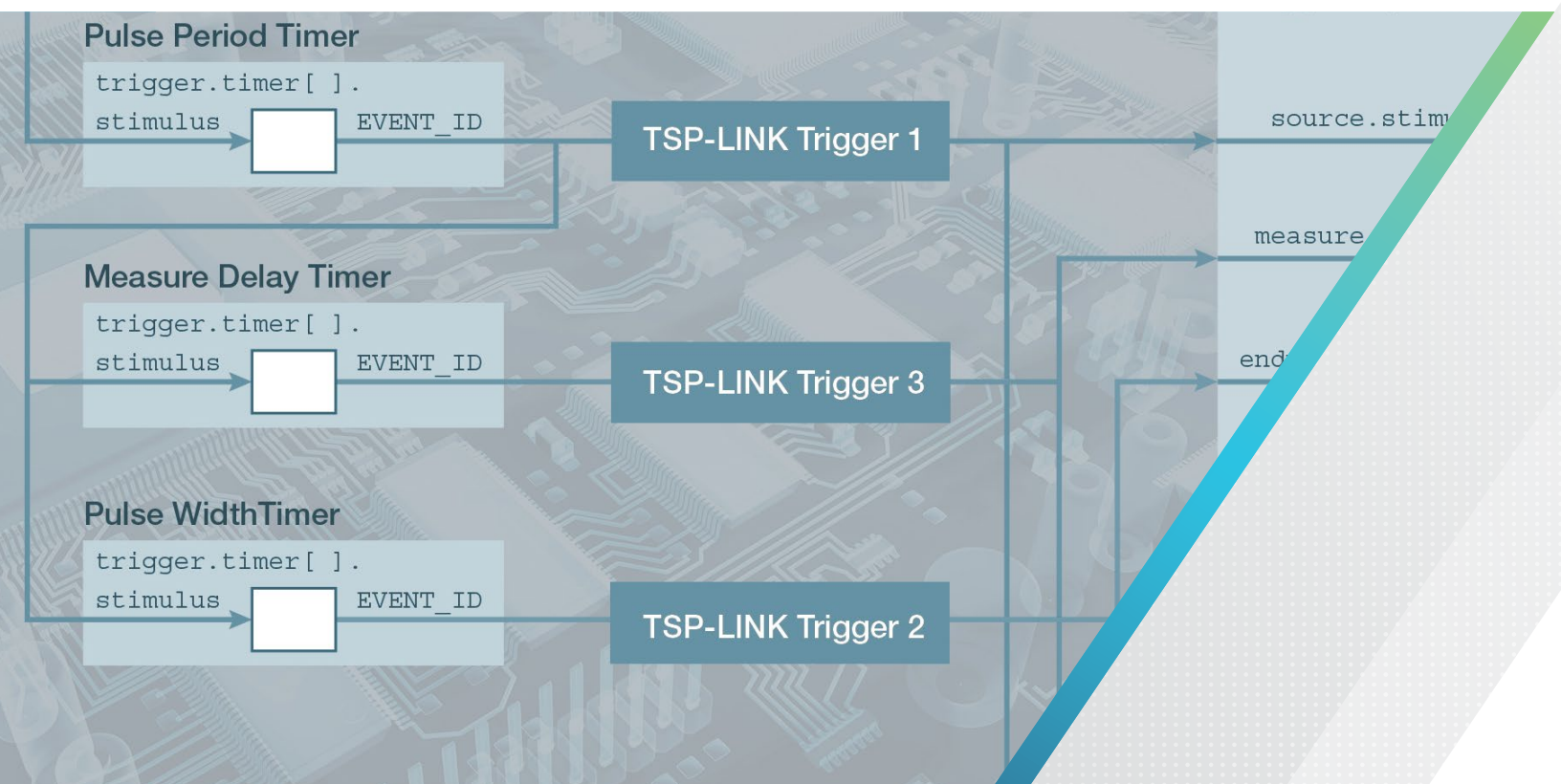

Introduction

A VCSEL (Vertical Cavity Surface Emitting Laser) is a semiconductor laser diode that emits a laser beam perpendicular to its top surface. These devices are used in many applications for illumination, sensing, spectroscopy, communications, with power levels ranging from milli-watts to tens of watts. Recently, the consumer electronics and automotive industries have been increasingly adopting VCSEL-enabled 3D sensing technology, thereby creating even higher demand for these devices and making developing fast, accurate, cost-effective strategies for production test crucial.

Unlike edge-emitting semiconductor lasers, which can't be tested until production is complete, VCSELs can be tested earlier in the production process at the wafer level (**Figure 1**). This allows identifying failed DUTs sooner, which allows eliminating the time and money associated with further processing steps for devices that would eventually be scrapped. It also allows flagging problems that occurred in earlier processing steps so they can be corrected quickly.

Synchronization challenges in a production environment

For a number of reasons, a key aspect of LIV—Light (output optical power)/Current/Voltage—testing is the precise control of timing and synchronization. Typically, LIV testing involves one instrument to pulse currents into the laser diode (LD) and another instrument to measure the light response from a photodiode (PD). The time response of the photodiode can impose different timing requirements on the photodiode channel versus the laser diode channel; however, the measurements from the photodiode are not asynchronous with the laser diode excitation. During an automated LIV sweep, it is important to prevent a loss of synchronization between the photodiode and the laser diode channels; if there is such a loss, false failures will appear as a “kink” in the first derivative of the light measurement to current drive, thereby presenting an incorrect slope efficiency result.

Because VCSEL tests are performed at wafer level, thermal management of the DUT is important. The probe station chuck or a thermoelectric cooler (TEC) is part of the thermal management. However, precise control of pulse width and duty cycle by the instrument is also an important consideration. Pulsed current should reach full current fairly quickly but not so fast that it causes overshoot and ringing.

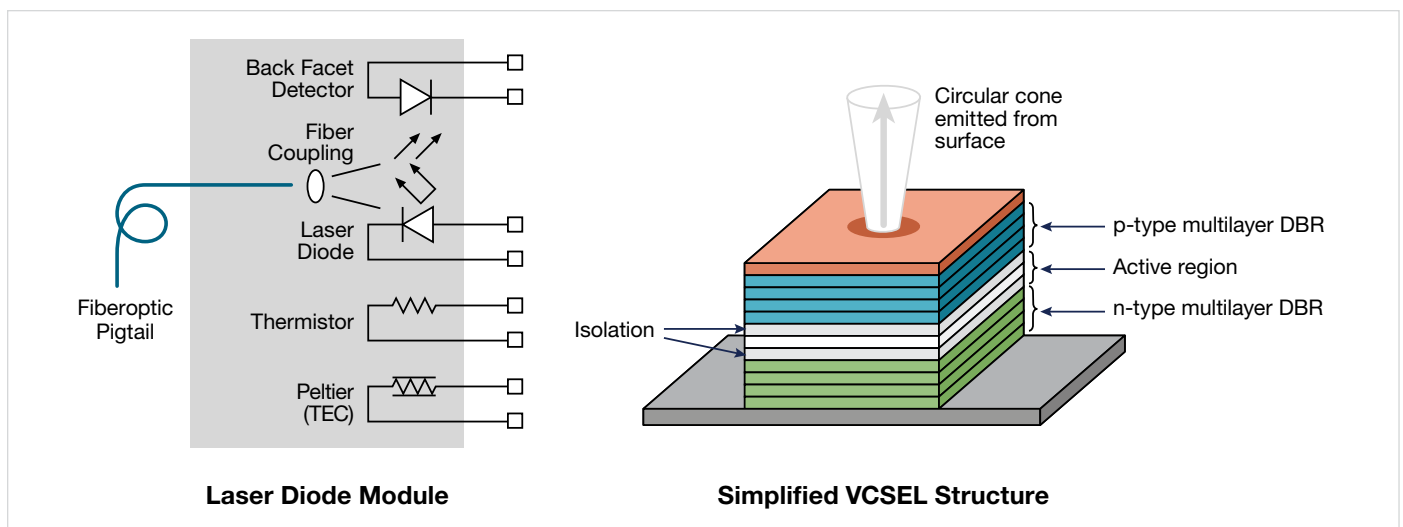

Figure 1. A simplified VCSEL structure.

Pulsed current should stay flat long enough to ensure that the result accurately represents the laser diode’s true output. Laser diodes become optically unstable a few microseconds after lasing is initiated as heat dissipation increases. This is accompanied by the optical output dropping to a fraction of the expected power level. Highly deterministic pulse control allows highly repeatable test outcomes by reducing signal uncertainty, therefore tremendously improving electrical measurement efficiency.

Efficiency and low cost of test are vital to any manufacturing production environment. Testing must be fast, accurate and inexpensive. The growth in VCSEL demand means that high volume VCSEL testing requires flexible system expansion capability to meet parallel testing requirements at different stages of a manufacturer’s workflow. The ideal instrument would allow for seamless integration of more or fewer parallel channels in order to achieve the desired throughput. Program consistency, minimal operator training, and consistent system performance with any number of channels are ideal qualifications.

In addition to the electrical tests, the light quality and wavelength spectrum analysis in the LIV testing can employ a variety of optical spectrum analyzers, spectrometers and cameras in the same system. Proper handshaking from VCSEL excitation to the light instrument is crucial to the entire LIV test. In many cases, the response time from light analysis instruments is slower than electrical measurement. In production, allowing customizable delay and recovery times for the light instruments becomes extremely challenging to handle in order maintain data synchronization and precision.

Techniques for boosting test speed

Keithley Series 2600B System SourceMeter® instruments (SMUs) are widely used for these applications because their high speed pulsing and measurement allow for faster testing, and their highly precise and synchronized trigger system reduces system overhead. The Series 2600B SMU trigger system incorporates TSP-Link interfaces for easy system scaling for multi-channel parallel testing, as well as digital I/O for interfacing with optical spectrum analyzers, spectrometers and cameras. The trigger model state machine in Series 2600B SMUs achieves pulse timing with less than 1 μs of jitter. These advantages support the use of a number of techniques that can help achieve maximum testing speed and measurement performance.

Flexible 2600B trigger model

The trigger model state machine in Series 2600B instruments is extremely powerful. Not only is it a robust source measure sequencer, it also has timer objects, event blender objects, as well as support for interfacing with digital I/O lines for input or output signaling with external equipment. The possible sequences are almost limitless. This allows a single half-rack instrument to perform both the laser diode and the photodiode measurements in a highly optimized way.

The triggering overview in **Figure 2** illustrates all the trigger objects in a Series 2600B SMU. These objects include two Trigger generators, eight timers, one manual front panel key trigger, six event blenders, 14 hardware digital I/O triggers, three hardware TSP-Link triggers, five LAN triggers and a software command trigger.

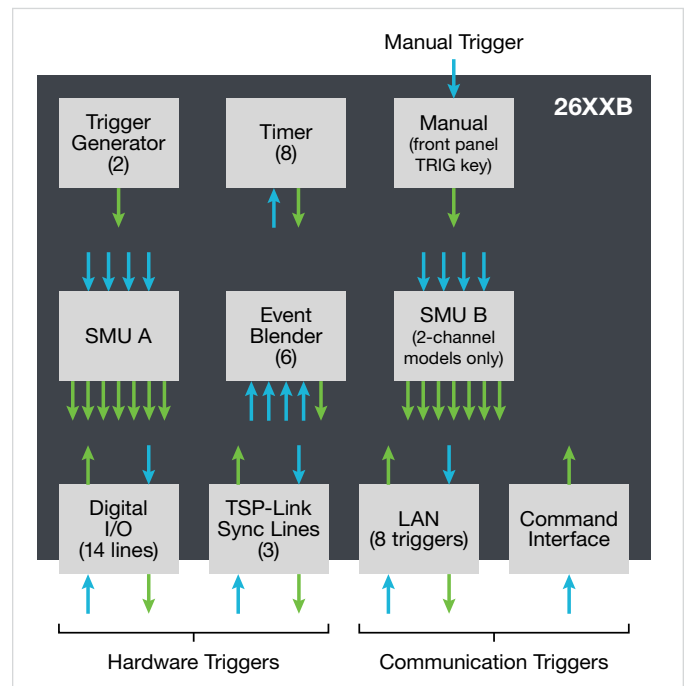

Figure 2. Triggering overview.

Each Series 2600B SMU operates on a state machine as illustrated in the flow chart for synchronous trigger model (**Figure 3**). The state machine consists of three layers: Idle, Arm, and Trigger. In an automated test environment, the SMU enters the Idle layer as soon as the instrument is put under remote control. When the *smuX.trigger.initiate()* command is received, the SMU will move into the Arm layer. The SMU can be configured to bypass or wait in the Arm layer for an *arm.stimulus* to go into the Trigger layer. As the Trigger layer is entered, the *ARMED_EVENT_ID* output signal occurs.

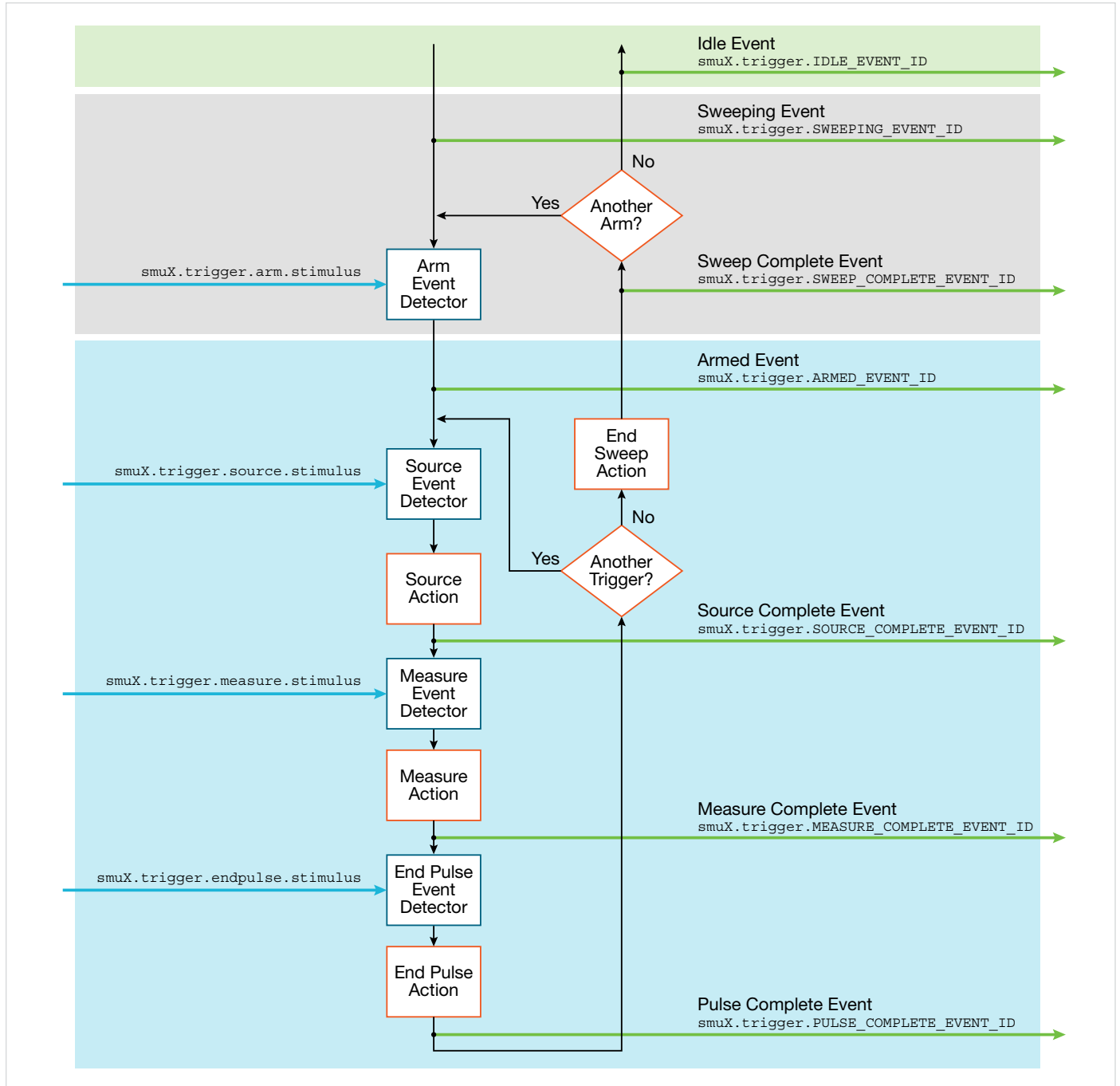

Figure 3. Flow chart for synchronous trigger model.

Output *EVENT_ID* notification can be used as stimulus signals to other trigger model objects, such as digital output to cause a hardware trigger to external instruments. While in the Trigger layer, the timing for the sourcing, measuring

and cessation of sourcing can be tightly controlled by using the input stimuli and the output *EVENT_ID* notifications. The instrument will stay in the Trigger layer until the trigger count is satisfied.

Series 2600B SMU Instruments for Production Testing

The features described above are available on any Series 2600B System SourceMeter® instruments, and users may select a specific model based on their current voltage requirements (see chart below). The 2606B is commonly recommended in applications like these where the current requirements are below 3 amps because it enables four channels in a compact, rack-mountable packaging.

MODEL	2601B	2602B	2604B	2611B	2612B	2614B	2634B	2635B	2636B	2606B	
Digits	6½	6½	6½	6½	6½	6½	6½	6½	6½	6½	
Quadrants of Operation	4	4	4	4	4	4	4	4	4	2	
Max Output Power	200 W Pulse, 40 W DC	200 W Pulse, 40 W DC/ Channel	200 W Pulse, 40 W DC/ Channel	200 W Pulse, 30 W DC	200 W Pulse, 30 W DC/ Channel	200 W Pulse, 30 W DC/ Channel	200 W Pulse, 30 W DC/ Channel	200 W Pulse, 30 W DC	200 W Pulse, 30 W DC/ Channel	20 W/ Channel	
SOURCE/ MEASURE											
I	min	±100 fA	±100 fA	±100 fA	±100 fA	±100 fA	±100 fA	±0.1 fA	±0.1 fA	±0.1 fA	±100 fA
	max	±10 A Pulse, ±3A DC	±10 A Pulse, ±3A DC	±10 A Pulse, ±3A DC	±10 A Pulse, ±1.5A DC	±10 A Pulse, ±1.5A DC	±10 A Pulse, ±1.5A DC	±10 A Pulse, ±1.5A DC	±10 A Pulse, ±1.5A DC	±10 A Pulse, ±1.5A DC	±3A Pulse, ±3A DC
V	min	±100 nV	±100 nV	±100 nV	±100 nV	±100 nV	±100 nV	±100 nV	±100 nV	±100 nV	±100 nV
	max	±40 V	±40 V	±40 V	±200 V	±200 V	±200 V	±200 V	±200 V	±200 V	±20 V
Basic Accuracy	I	0.020%	0.020%	0.020%	0.020%	0.020%	0.020%	0.020%	0.020%	0.020%	0.020%
	V	0.015%	0.015%	0.015%	0.015%	0.015%	0.015%	0.015%	0.015%	0.015%	0.015%
GENERAL FEATURES											
Reading Speed	20,000 rdgs/s	20,000 rdgs/s	20,000 rdgs/s	20,000 rdgs/s	20,000 rdgs/s	20,000 rdgs/s	20,000 rdgs/s	20,000 rdgs/s	20,000 rdgs/s	20,000 rdgs/s	
TSP-Link	Yes	Yes	No	Yes	Yes	No	No	Yes	Yes	Yes	
Digital I/O	Yes	Yes	No	Yes	Yes	No	No	Yes	Yes	Yes	
Computer Interface	USB 2.0 LAN/LXI-C IEEE-488 RS-232	USB 2.0 LAN/LXI-C IEEE-488 RS-232	USB 2.0 LAN/LXI-C IEEE-488 RS-232	USB 2.0 LAN/LXI-C IEEE-488 RS-232	USB 2.0 LAN/LXI-C IEEE-488 RS-232	USB 2.0 LAN/LXI-C IEEE-488 RS-232	USB 2.0 LAN/LXI-C IEEE-488 RS-232	USB 2.0 LAN/LXI-C IEEE-488 RS-232	USB 2.0 LAN/LXI-C IEEE-488 RS-232	USB 2.0 LAN/LXI-C only	

Synchronized Laser Diode and Photodiode trigger model implementation

Now, let us take a look an example of coordinating a laser diode and a photodiode sweep using a single dual-channel Series 2600B SMU (The same concept applies to a single four-channel 2600B SMU). The trigger model can be set up as shown in **Figure 4**.

For a pulse I-V sweep test, it is essential to control:

- The start of current sourcing,
- The start of measuring upon sufficient settling time, and
- The cessation of current sourcing.

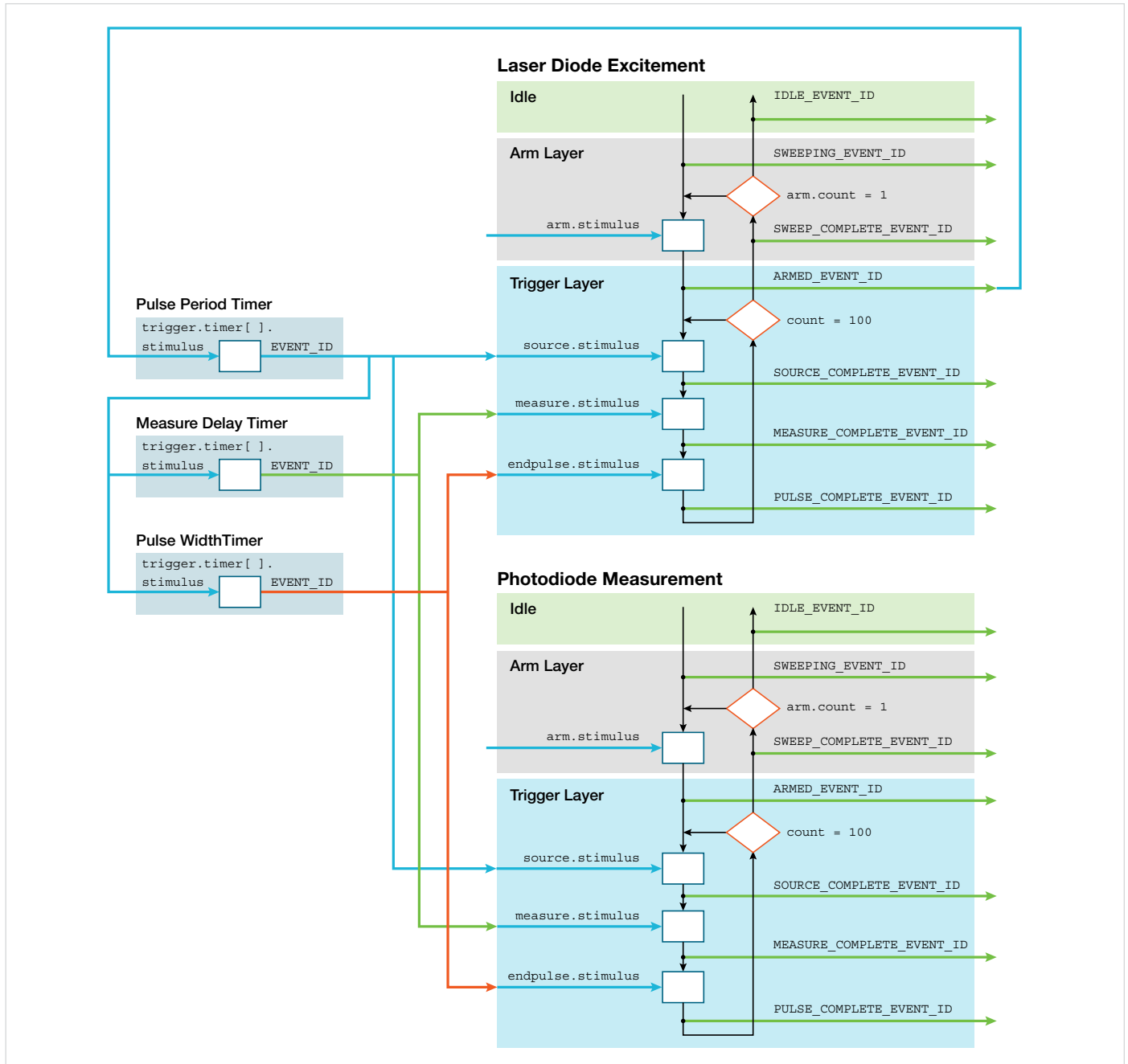

Figure 4. Series 2600B trigger model interconnect for a coordinated laser diode and photodiode sweep.

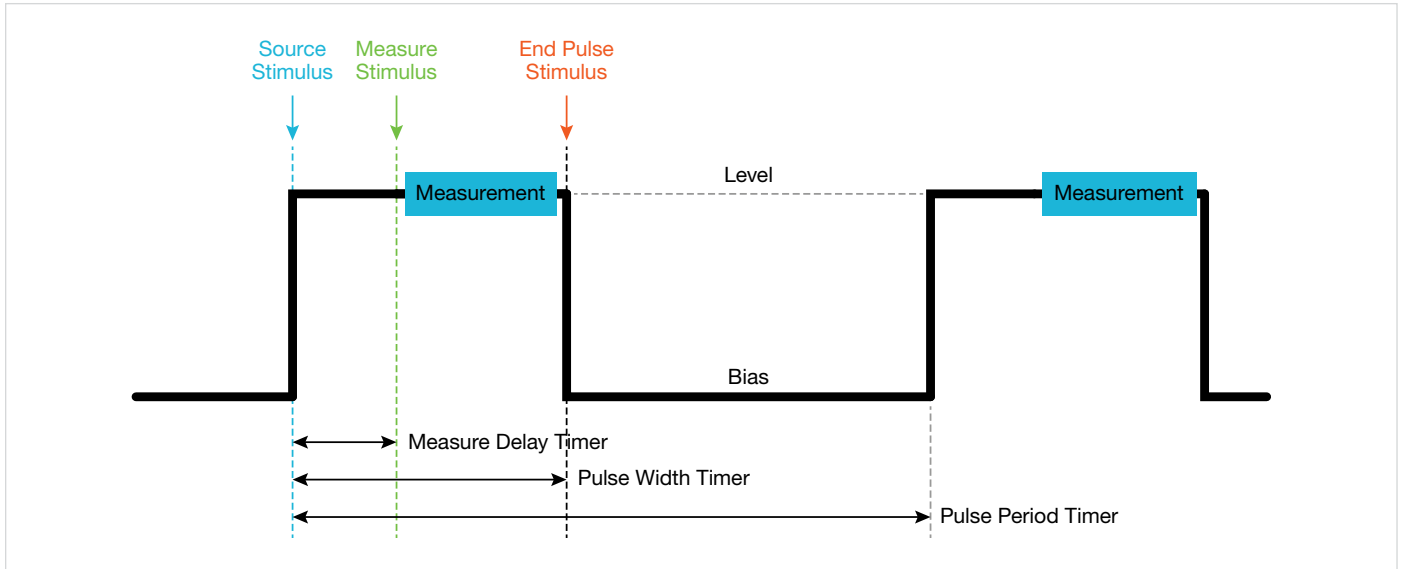

Figure 5. Laser diode and photodiode pulse I-V sweep pulse diagram.

The trigger model provides three input stimuli event detectors for these coordinated actions:

- Source stimulus
- Measure stimulus
- Endpulse stimulus

A timer object is used to control the overall pulse period for the I-V sweep. For an N point sweep, we can program this timer to issue *N number of EVENT_ID* output signals. Additional timer objects, such as pulse width timer and

measure delay timer, use the pulse period output signal to count down and then raise their output signal *EVENT_ID*. This allows both the measure delay and the endpulse to occur after a suitable delay relative to the start of the pulse.

TSP-Link enabled synchronized multi-channel system

The TSP-Link interface allows treating the laser diode—photodiode (source—measure) test sequence written for a single paired action as an object and easily running it with up to 32 physical 2600B SMUs (nodes) that are added to the TSP-Link network.

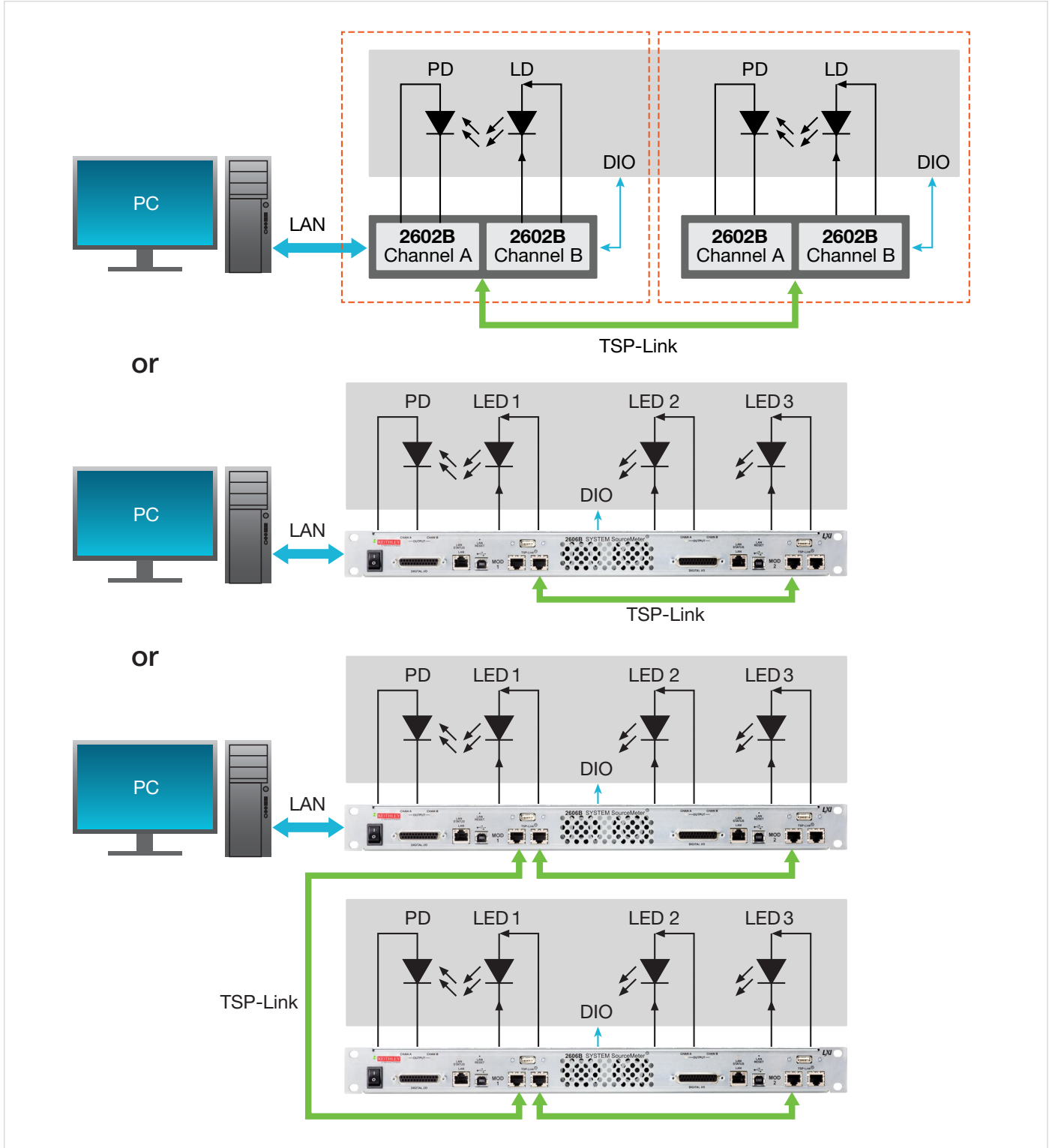

Figure 6. TSP-Link enabled multi-channel system.

Within each single-node implementation, the two SMU channels in a single two-channel or single four channel 2600B SMU can directly share output *EVENT_ID* notifications. However, with multiple 2600B SMUs, that is, multiple remote nodes, *EVENT_ID* notifications need to be echoed on the TSP-Link trigger lines. Therefore, it is a good practice to implement the TSP-Link triggering even when dealing with a single node or a single two-channel or four-channel 2600B SMU because it simplifies future system expansions.

To program the TSP-Link trigger lines to “echo” a local node event, simply add a line of code like this:

```
node[1].tsplink.trigger[1].stimulus = node[1].trigger.timer[1].EVENT_ID
```

Remote nodes can then be programmed to consume the *EVENT_ID* of the TSP-Link trigger line with a line of code like this:

```
node[2].smua.trigger.source.stimulus = node[2].tsplink.trigger[1].EVENT_ID
```

Figure 7 illustrates a modified trigger model for sharing trigger signals with remote nodes.

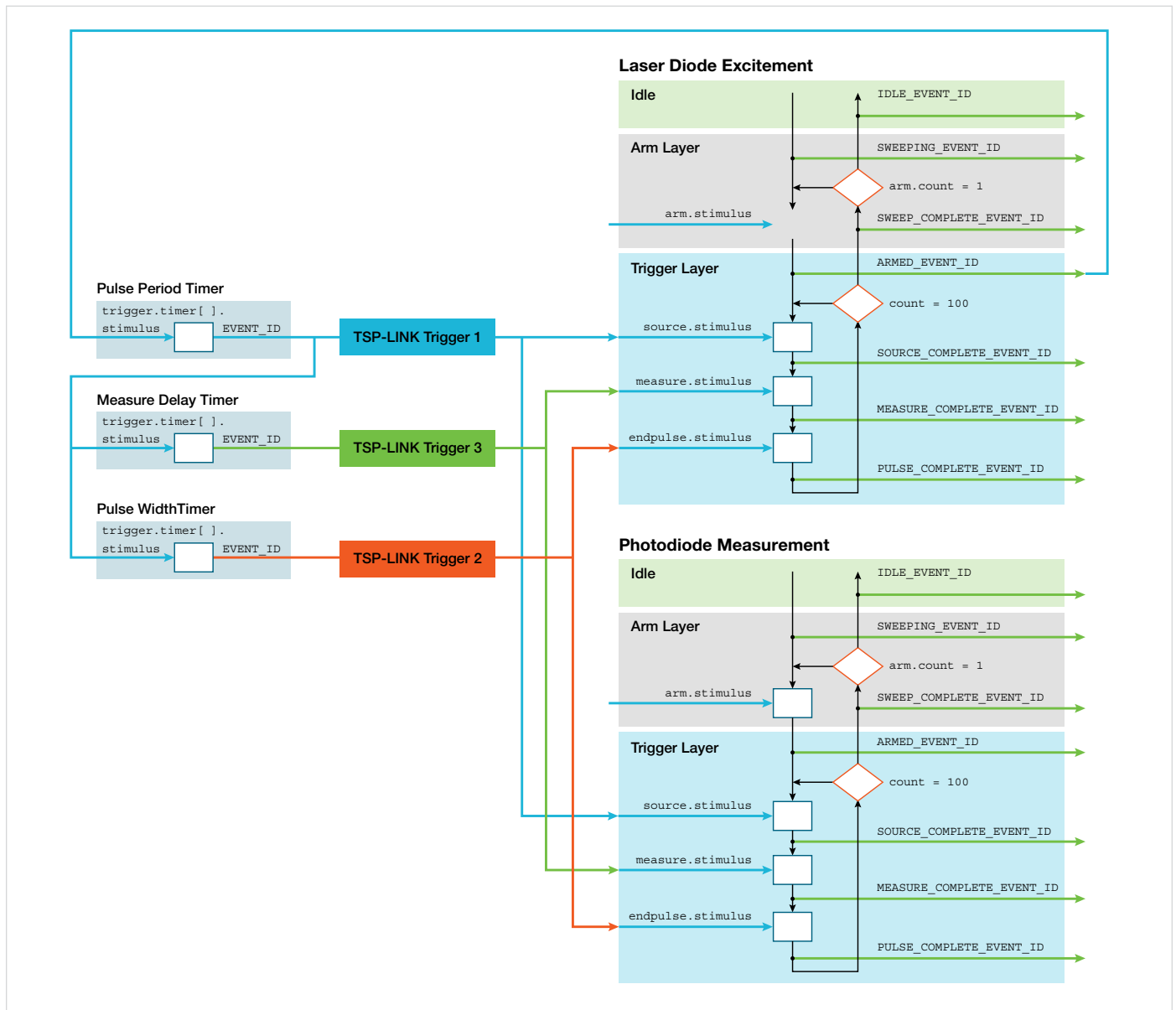

Figure 7. Modified trigger model for sharing trigger signals with remote nodes.

Closed-loop triggering scheme maintains synchronization with auto-range

In the preceding laser diode pulse I-V sweep example, fixed ranges for both sourcing and measurement are being used in order to accommodate the requested pulse timing. Whenever range changes are allowed, the overall task timing and synchronization become more complex. For DC sweeps or leakage current measurements, utilizing auto-range is advantageous to preserve source and measure accuracy over the entire dynamic operating voltage and current region, if the resulting timing variability is tolerable. A closed-loop triggering scheme may be needed when auto-ranging is in use in order to maintain synchronization across multiple 2600B nodes. This scheme ensures that no sequence action will take place until the previous action completes. In other words, it would prevent sourcing the next current value in the sweep until all SMUs report “measure complete” with the prior measurement. Likewise, the start of measuring could be

prevented until all SMUs have completed and stabilized all the source current values

When performing parallel testing with a large number of SMUs, as in a production environment, the hardware handshaking (i.e., triggering) required for the desired closed-loop control for all SMUs is greatly simplified by using one or more of the three hardware trigger lines within the TSP-Link interface, along with the Synchronous Master and Synchronous Acceptor trigger modes. **Figure 8** shows four instruments in a closed-loop control scheme using conventional triggering. Instrument #1, the trigger master, outputs a negative pulse. Instruments #2, #3 and #4, the trigger slaves, detect the falling edge and perform their operations. When their operations complete, the trigger slaves each output a trigger pulse. The AND gate represents the logic to combine the trigger slave pulses into a single pulse returned to the trigger master. The trigger master detects the falling edge of the trigger pulse, and then performs its next operation.

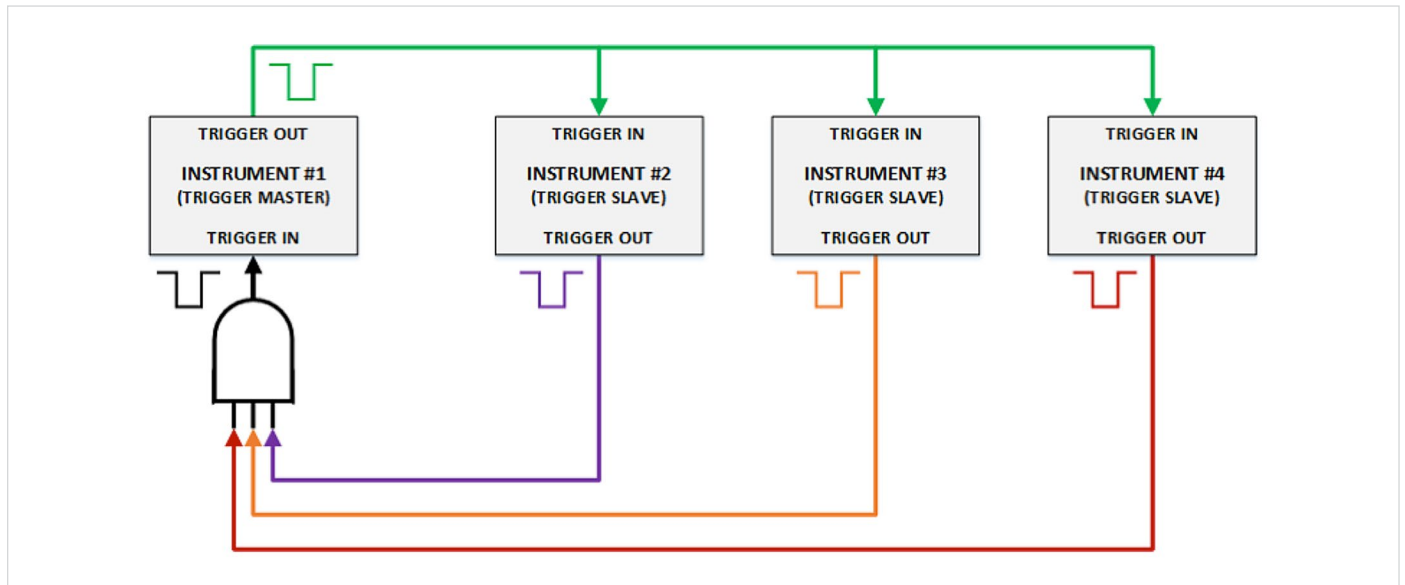

Figure 8. Closed loop control scheme using conventional triggering.

Figure 9 shows the timing diagram of synchronous trigger modes operation. TSP-Link Node #1, the trigger master, completes some operation and then pulses the trigger line low. TSP-Link Nodes #2, #3 and #4, the trigger slaves, detect the falling edge trigger and begin their operations. At the same time, they all latch the trigger line low. When all nodes are no longer being held low, the trigger line changes state and goes high. The trigger master detects the rising edge trigger and performs its next operation. The process continues until all trigger counts are satisfied.

For example, coordinating on *MEASURE_COMPLETE_EVENT_ID* with two single-channel 2600B nodes (SMUs), the

Synchronous Master node combines measure complete from its two SMU channels and the TSP-Link trigger line controlled by the Synchronous Acceptor nodes.

For extra time savings, it's also possible to raise an SRQ on a user-defined event. This allows better coordination of when tasks are performed, such as having the SMU signal that a test is done so that the controller can command stepping to the next site on the wafer, and then download data from the instrument while the prober is finishing the move to the next site. This puts time that would otherwise be wasted to productive use.

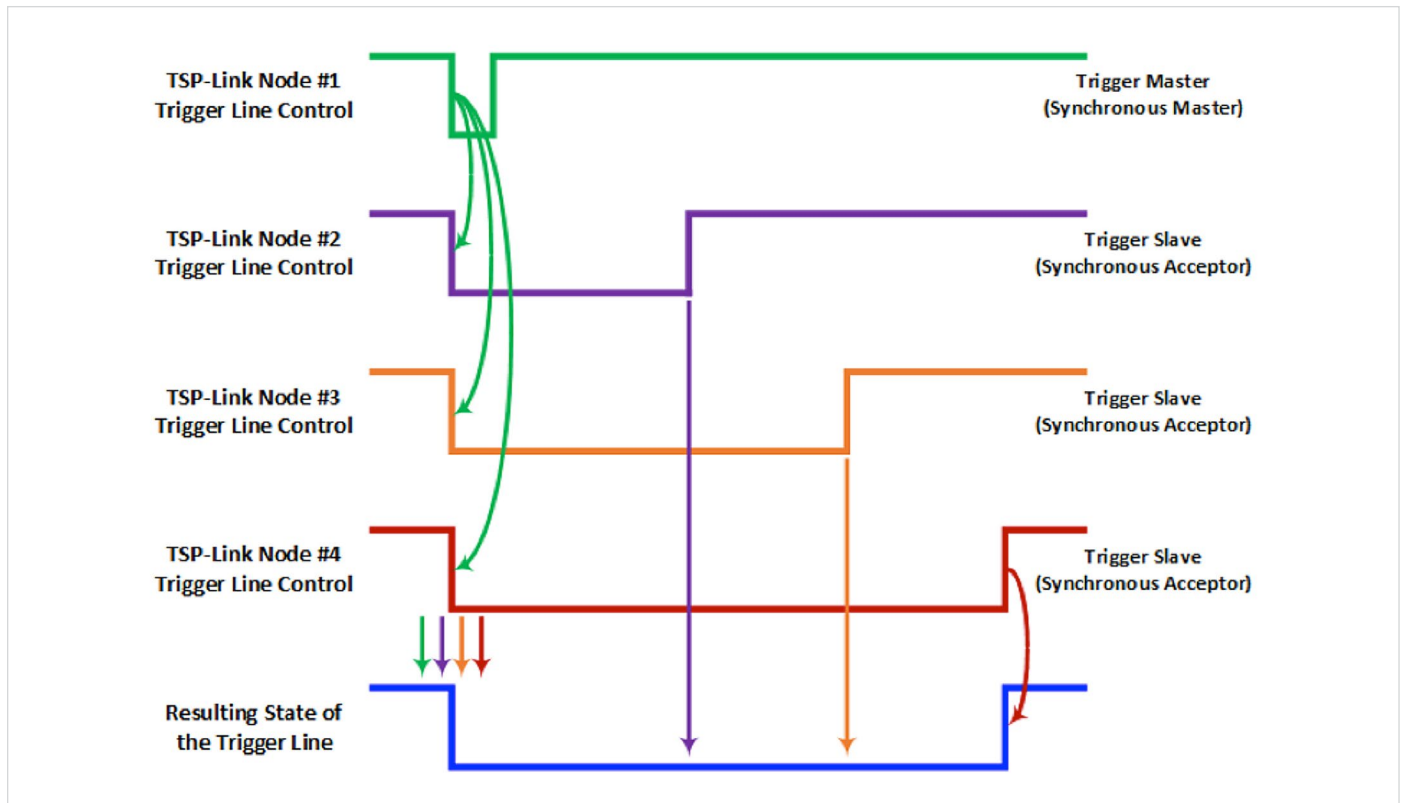

Figure 9. How the Synchronous Master and Acceptor trigger modes work.

Test Script Processing

TSP processing allows code to be organized into logical functions that can be called as needed. The function names and the parameters are defined by the user and become customized APIs. The logic for decision-making, such as repeat until or do while, can be performed within the Series 2600B SMU's TSP scripting engine. This greatly reduces the content that must be transferred via the bus to the test executive and speeds up the overall process. Let us suppose these were the commands to perform an LIV test:

First Initialization:

```
--define some variables
local NumSystemNodes = 1
local PulsePeriod = 0.012
local PulseWidth = 0.001
local MeasDelay = 400e-6
-- compute NPLC value that is compatible with pulse width and measure delay timing
local nplc = (PulseWidth - MeasDelay - 50e-6) * 60

local currentSweepStartVal = 0.01
local currentSweepStopVal = 0.01
local numPulses = 5

--call our init function
Init(NumSystemNodes)
```

Configure the PD and LD channels:

```
-- config the Laser Diode SMU: force I and measure V
--function prototype:
--LD_Config(nodenum, node[x].smuX, start, stop, numPoints, limitV, nplc, remoteSense)
LD_Config(1, node[1].smua, currentSweepStartVal, currentSweepStopVal, numPulses, 10, nplc, true)
-- config the Photo Detector SMU: force 0 volts and measure i
--function prototype:
--PD_Config(nodenum, node[1].smub, start, stop, numPoints, limitI, nplc, remoteSense)
PD_Config(1, node[1].smub, 0, 0, numPulses, 0.125, nplc, false)
```

Run the test:

```
for i = 1 , 1 do
  timer.reset()
  --LIV_test(show_data, PulsePeriod, PulseCount, PulseWidth, MeasDelay)
  LIV_test(true, PulsePeriod, numPulses, PulseWidth, MeasDelay) -- pass true to print data back
  to console
  time = timer.measure.t()
  print("Time to run the sweep and xfer data: %.time)
  timer.reset()
  LIV_test(false, PulsePeriod, numPulses, PulseWidth, MeasDelay) -- pass false
  time = timer.measure.t()
  print("Time to run the sweep: %.time)
  print("*****")
end
```

The free Keithley Test Script Builder prototyping environment (Figure 10 to Figure 14) allows executing the code against the hardware and viewing the output. This development approach allows unit testing of code blocks and a high degree of confidence in the instrument-specific code before porting it to the Test Executive (VS.NET, LabVIEW®, etc.).

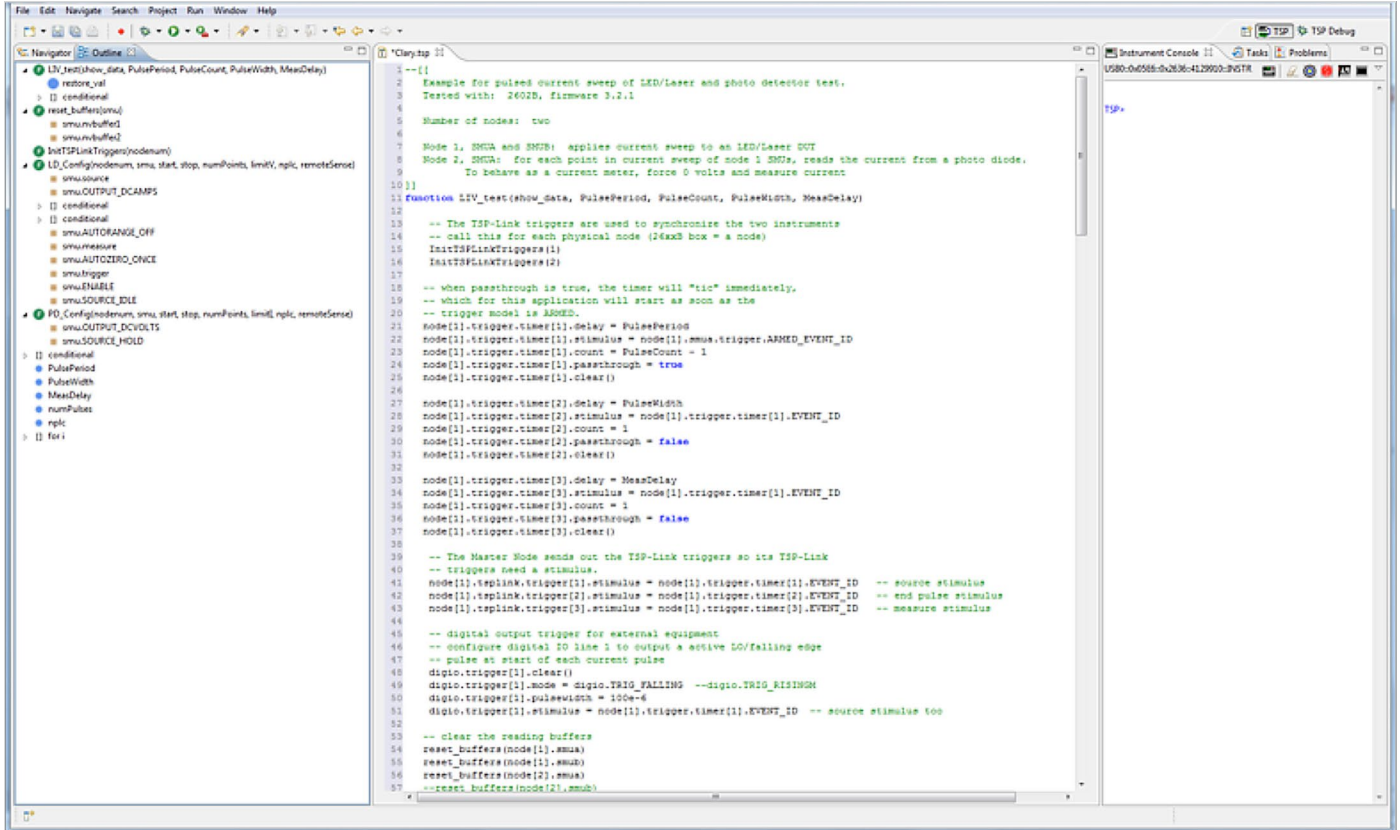

Figure 10. Test Script Builder work environment.

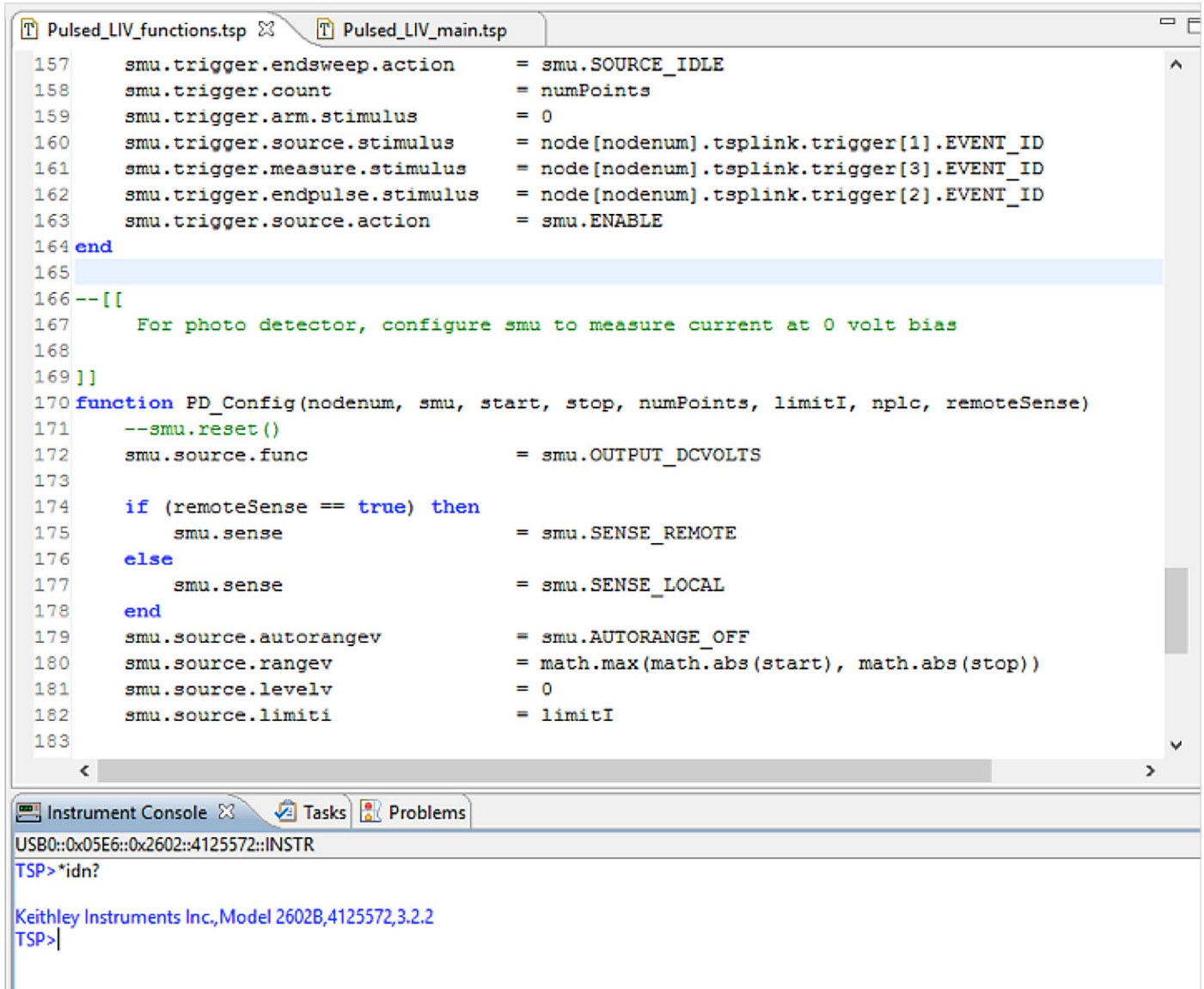

Figure 11 Test Script Builder active project with instrument console.

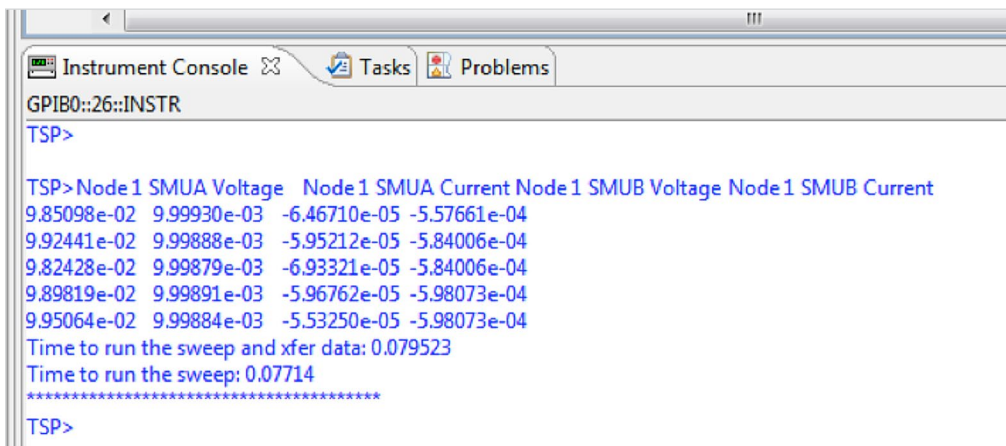

Figure 12. Test Script Builder interactive console.

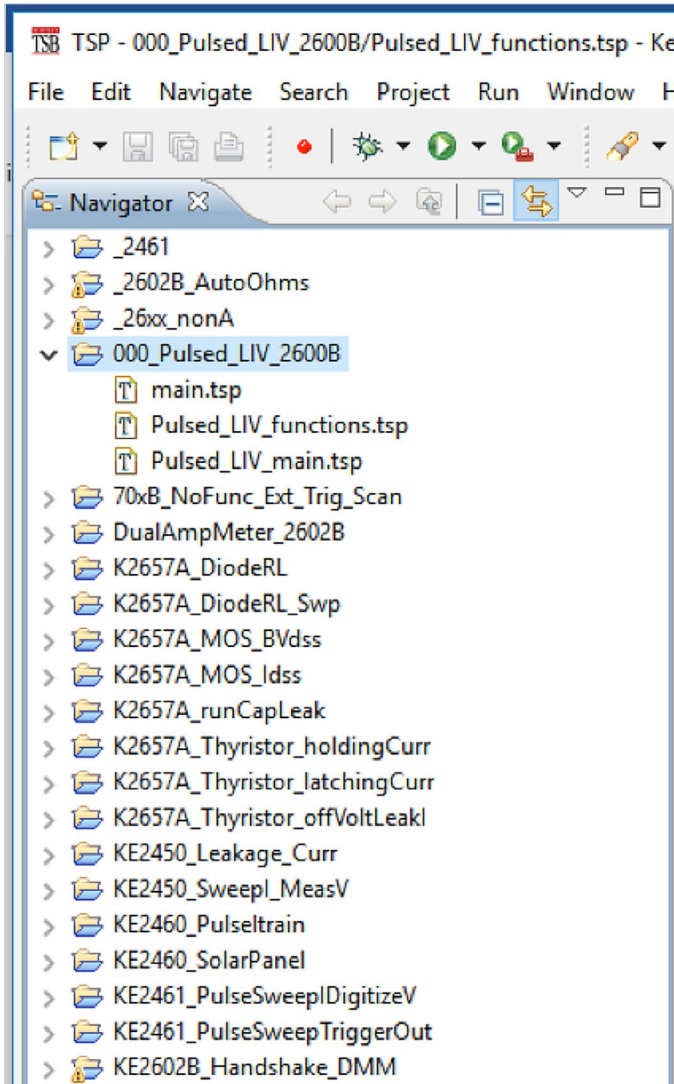

Figure 13. Test Script Builder project navigator.

Note on the built-in *smu.trigger.source.XX* sweep commands:

The built-in pulse sweep command can greatly simplify coding a linear pulse sweep waveform as shown in **Figure 15**. Simply call this TSP command:

```
smuX.trigger.source.linearI(start, stop, numPoints)
```

where the start and stop values don't need to be different from each other. This allows the linear sweep function to specify a bias condition with multiple measurements coincident with the "sweep steps." This feature of the "sweep" function can greatly simplify coding.

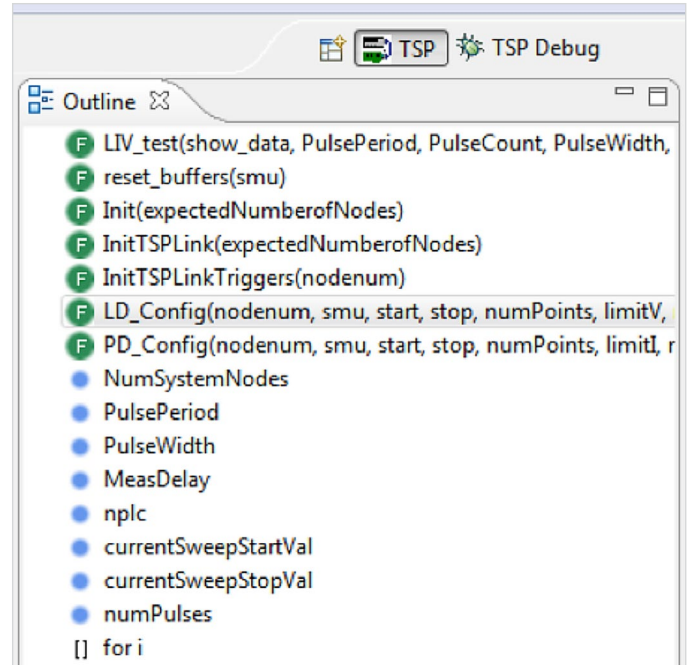

Figure 14. Test Script Builder user-defined functions and parameters.

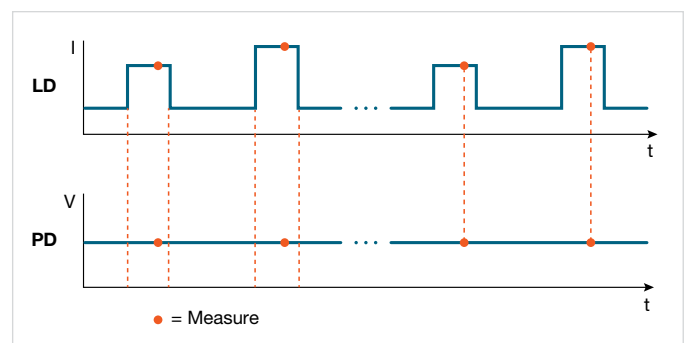

Figure 15. Pulse I-V sweep.

Integrated Switching through TSP-Link

TSP-Link enabled switching hardware, such as the 3706A System Switch/Multimeter, with the 3760 10-Channel High Current Multiplexer Card, should be considered for wafer-level probing where it's desirable to test multiple devices for each touchdown on the wafer but that are not true SMU-per-pin situations. The current carrying capacity of the switch, as well as the bandwidth of the cabling, switches, and probe card should be considered. Typical maximum current carrying capacity with respect to duty cycle is shown in **Figure 16**. Care should be taken to minimize the capacitive and inductive aspects that can interfere with delivering well-formed pulses to the DUT.

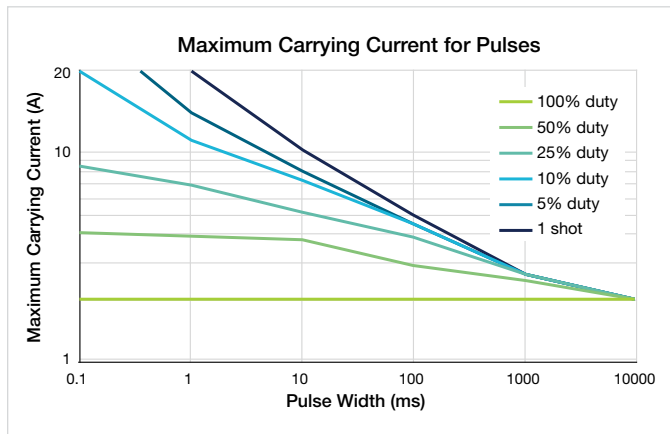

Figure 16. Maximum current carrying capacity and pulse width.

De-trapping device charges during production

It is not uncommon to see the voltage remains at a non-zero state in a high speed LIV sweep. For example, **Figure 17** illustrates the voltage profile for 100 mA current pulses with a resistor. Note how the voltage response starts and returns to 0 V after each current pulse. In contrast, the result of the same 100 mA current pulses with a diode or laser diode will look like **Figure 18**.

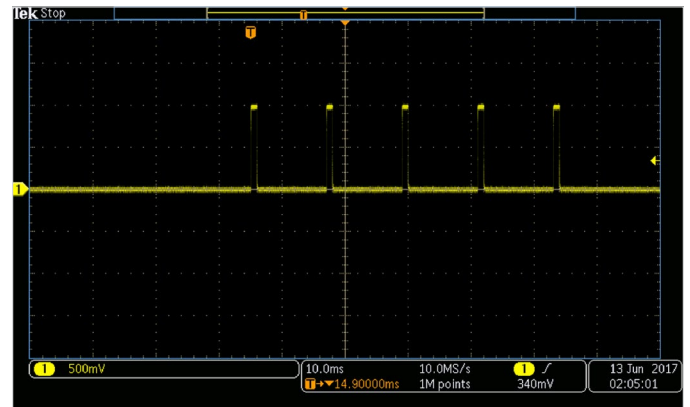

Figure 17. Voltage profile for 100 mA current pulses with a resistor.

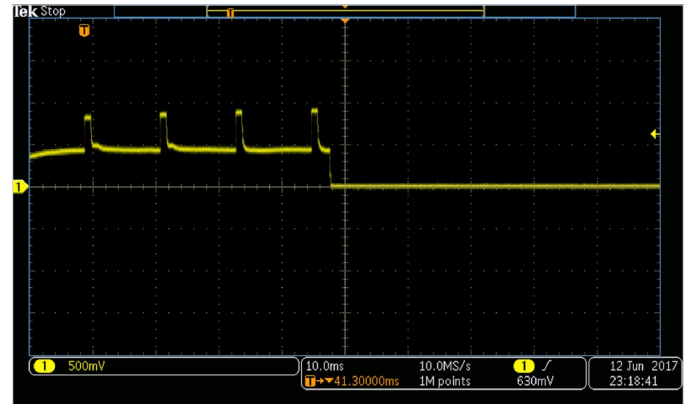

Figure 18. Voltage profile for 100 mA current pulses with a diode or laser diode.

The voltage level in between the four pulses above does not return to 0 V because the SMU is in a high impedance state when forcing current, at 0 A in this case. Charge trapped on the junction capacitance of the DUT from the pulse testing cannot discharge, or bleed off, into a high impedance current source in a short time frame, and it results in a non-zero voltage across the laser diode.

In order to discharge the DUT back to 0 V, the SMU must bleed off the stored charge, which requires the SMU to leave the “sourcing 0 A” high impedance state briefly. There are several ways to accomplish this. One is to lower the voltage limit briefly while staying in the force current mode of operation. A lower voltage limit, in this scenario, forces the SMU into voltage compliance as a constant voltage source. The excess voltage can be removed quickly, as shown in **Figure 18**, where the voltage was returned to 0 V after the fourth pulse. Alternatively, reset the SMU to voltage source mode to perform charge de-trapping by measuring a leakage or dark current of the photodiode under reverse voltage bias. Resetting this test will also allow the discharge.

When switching is involved, to extend switch contact life, cold switching is always advised when stepping to the next site on the wafer or switching to the next DUT with a multiplexer. That makes it important to eliminate the non-zero voltage at the end of the LIV sweep before breaking contact with the DUT.

Checking for contact in production

The wattages that VCSELS can produce are becoming increasingly impressive and the current amplitudes used during the tests are well into the single-digit amps range. For currents of this magnitude, it is important to use four-wire or Kelvin connections from the DUT. The Series 2600B’s contact check feature allows verification of the low ohms Kelvin point so that the LIV sweep is only performed when a reliable contact is made. An additional cabling consideration is the use of the cable guard and triax cables. Even when the currents being measured aren’t very small leakage currents, the guarded cable improves response time by charging the guard to LO system capacitances quickly.

Conclusion

This application note uncovers several effective test methodologies for achieving a highly synchronized trigger system on a Keithley Series 2600B SMU. SMU instruments also further enhance this capability through TSP scripting and TSP-Link hardware triggering, so users of any level can easily maximize the advantages of a Series 2600B SMU.

Series 2600B System SourceMeter® instruments are an excellent choice for production testing of VCSELS because of they provide:

- High speed embedded programming
- 1, 2, or 4-channel options
- Source up to 10 A Pulse, 200 V, 200 W
- Measure down to 0.1 fA, 100 nV

The 2606B System SourceMeter Source Measure Unit (SMU) Instrument offers four 20-watt SMU channels in a 1U high form factor chassis. The result is a powerful solution that significantly boosts productivity for demanding automated qualification and production testing for optoelectronic devices.

To learn more about laser diode I-V characterization from bench to mass production environment, or download the full script described in this application note, please visit www.tek.com.

Contact Information

Australia* 1 800 709 465
Austria 00800 2255 4835
Balkans, Israel, South Africa and other ISE Countries +41 52 675 3777
Belgium* 00800 2255 4835
Brazil +55 (11) 3759 7627
Canada 1 800 833 9200
Central East Europe / Baltics +41 52 675 3777
Central Europe / Greece +41 52 675 3777
Denmark +45 80 88 1401
Finland +41 52 675 3777
France* 00800 2255 4835
Germany* 00800 2255 4835
Hong Kong 400 820 5835
India 000 800 650 1835
Indonesia 007 803 601 5249
Italy 00800 2255 4835
Japan 81 (3) 6714 3086
Luxembourg +41 52 675 3777
Malaysia 1 800 22 55835
Mexico, Central/South America and Caribbean 52 (55) 56 04 50 90
Middle East, Asia, and North Africa +41 52 675 3777
The Netherlands* 00800 2255 4835
New Zealand 0800 800 238
Norway 800 16098
People's Republic of China 400 820 5835
Philippines 1 800 1601 0077
Poland +41 52 675 3777
Portugal 80 08 12370
Republic of Korea +82 2 6917 5000
Russia / CIS +7 (495) 6647564
Singapore 800 6011 473
South Africa +41 52 675 3777
Spain* 00800 2255 4835
Sweden* 00800 2255 4835
Switzerland* 00800 2255 4835
Taiwan 886 (2) 2656 6688
Thailand 1 800 011 931
United Kingdom / Ireland* 00800 2255 4835
USA 1 800 833 9200
Vietnam 12060128

* European toll-free number.

If not accessible, call: +41 52 675 3777

Rev. 090617



Find more valuable resources at TEK.COM

Copyright © Tektronix. All rights reserved. Tektronix products are covered by U.S. and foreign patents, issued and pending. Information in this publication supersedes that in all previously published material. Specification and price change privileges reserved. TEKTRONIX and TEK are registered trademarks of Tektronix, Inc. All other trade names referenced are the service marks, trademarks or registered trademarks of their respective companies.

083018 SBG 1KW-61292-1

