

Generating Advanced Radar Signals Using Arbitrary Waveform Generators

Application Note

Radar signal generation and processing techniques are growing ever more advanced. These advances are being driven by the need to improve resolution (the ability to detect targets that are very close together) and reduce radar spectrum occupancy. Reducing spectral occupancy can serve two goals: reduce interference and minimize the probability of intercept (POI). These advanced designs are being implemented as digital radar where the data converters are very close to the antenna and parameters such as demodulation, matched filtering, range gating, etc. are performed using digital signal processing (DSP). Field Programmable Gate Arrays (FPGAs) are emerging as a useful approach to digitally implemented radar systems due to flexibility and cost reduction. The use of FPGAs and DSP

means that the effectiveness of the radar system is becoming increasingly dependent on the pre-distortion, filtering and detection algorithms.

This application note will provide a summarized review of radar essentials and some of the challenges in modern radar systems. This is followed by an explanation of how to take advantage of the increased sample rate, analog bandwidth, memory, and digital outputs found in the Arbitrary Waveform Generators (AWGs) in order to: increase resolution, decrease false target returns, and increase the probability of detecting actual targets. The last section will cover troubleshooting the radar transceiver chain and generation of a phase modulated (Frank Code) pulsed radar signal using Tektronix RFXpress software.

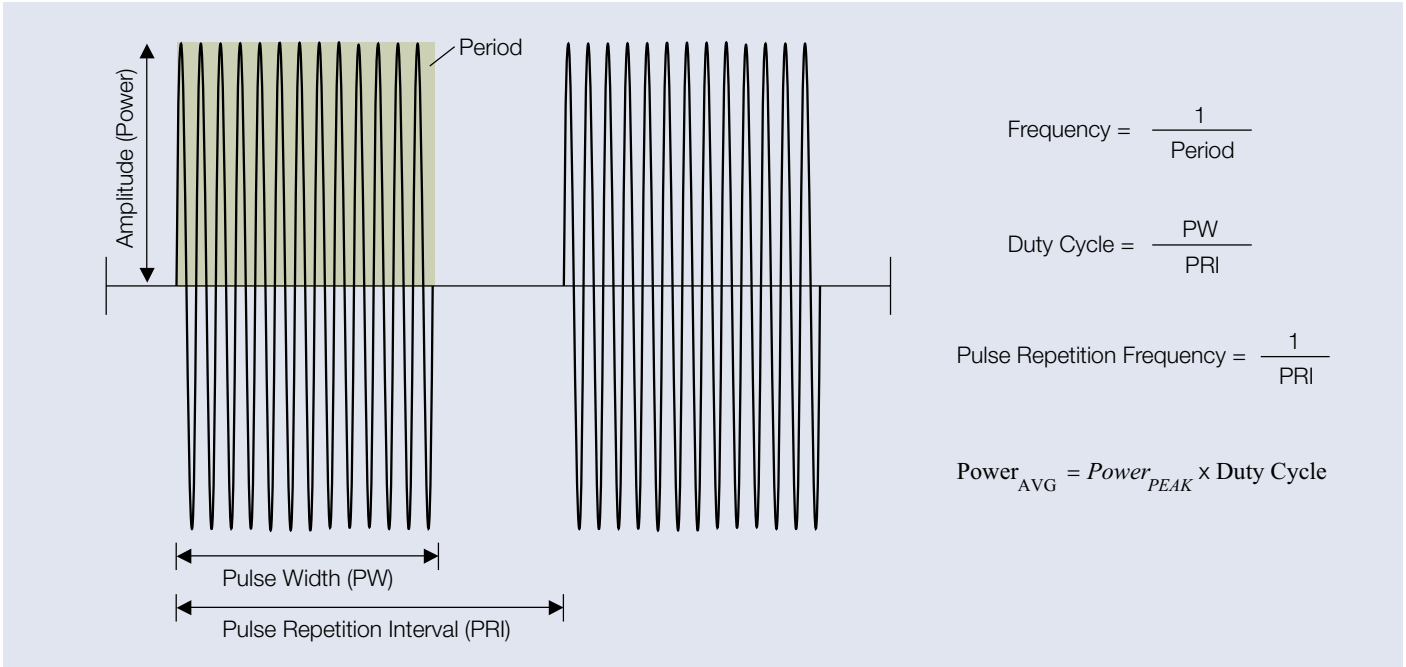

Figure 1. Basic pulsed radar parameters.

Radar Range and Resolution - the Fundamental Challenge

As with most transceiver design, radar is all about trade-offs; the transceiver typically gives up effectiveness in one parameter (for example resolution) in order to achieve better performance in another parameter (for example. range). Let's begin by discussing some fundamentals of radar range and resolution. Figure 1 includes the basic concepts and terms used in this section.

The first concept to understand is the range equation which tells us how much power that has been reflected from the target will be present at the radar receiver. The radar range equation and its defined variables are shown in Equation 1.

$$P_r = \frac{P_t G_t A_r \sigma}{(4\pi)^2 R^4}$$

- P_r = power at Rx
- P_t = average Tx power
- G_t = gain of Tx antenna
- A_r = area of Rx antenna
- σ = target scattering coefficient
- R = target distance

Equation 1. The Radar Range Equation.

If it is desired to have increased range by increasing the reflected power from the target, why not simply increase the average transmitted power (P_t in the numerator of the range equation) in order to increase P_r ? The answer lies in the fact that it is average power, meaning power integrated over time, which includes the time when no signal is being transmitted. So, as we recall from Figure 1, in order to increase average power, we need to increase the peak power or the duty cycle.

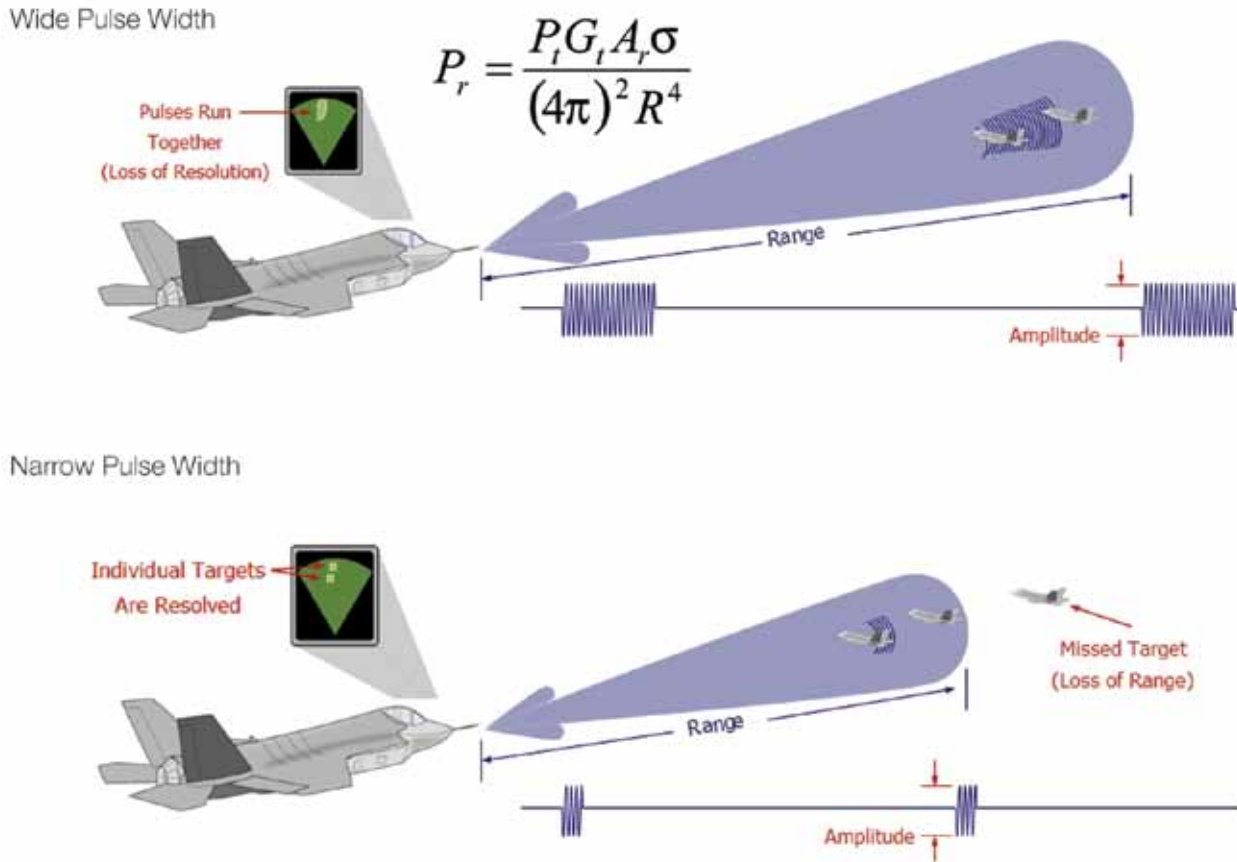

Figure 2. Range versus resolution.

Increasing the peak power increases the complexity and cost of hardware such as klystron amplifiers, and all associated hardware in the transceiver chain has to be able to handle the larger peak power output. The other way to increase the average power is to increase the average “on time” of the RF burst, i.e. increase the duty cycle. While some radar systems are designed to “jitter” or vary the PRI over time, the most desirable method of increasing the duty cycle is to increase the pulse width. This is primarily due to the strain put on the transceiver by rapidly switching on and off the RF burst when increasing the PRI.

One significant disadvantage of increasing the pulse width is that resolution suffers. For a radar with an unmodulated pulse to resolve two targets in range, their range separation must be such that the trailing edge of the transmitted pulse will have passed the near target before the leading edge of the echo from the far target reaches the near target. This is illustrated in the Figure 2. As seen here, when the pulse is transmitted for a longer period of time, targets which are close together will both be the same pulse. This means that the return pulse (echo) from these returns will be overlapped, making it difficult to distinguish one from the other. Using a narrower pulse width, as seen in the bottom half of Figure 2, allows for the illumination of only one target at a time; however, the more distant target is missed.

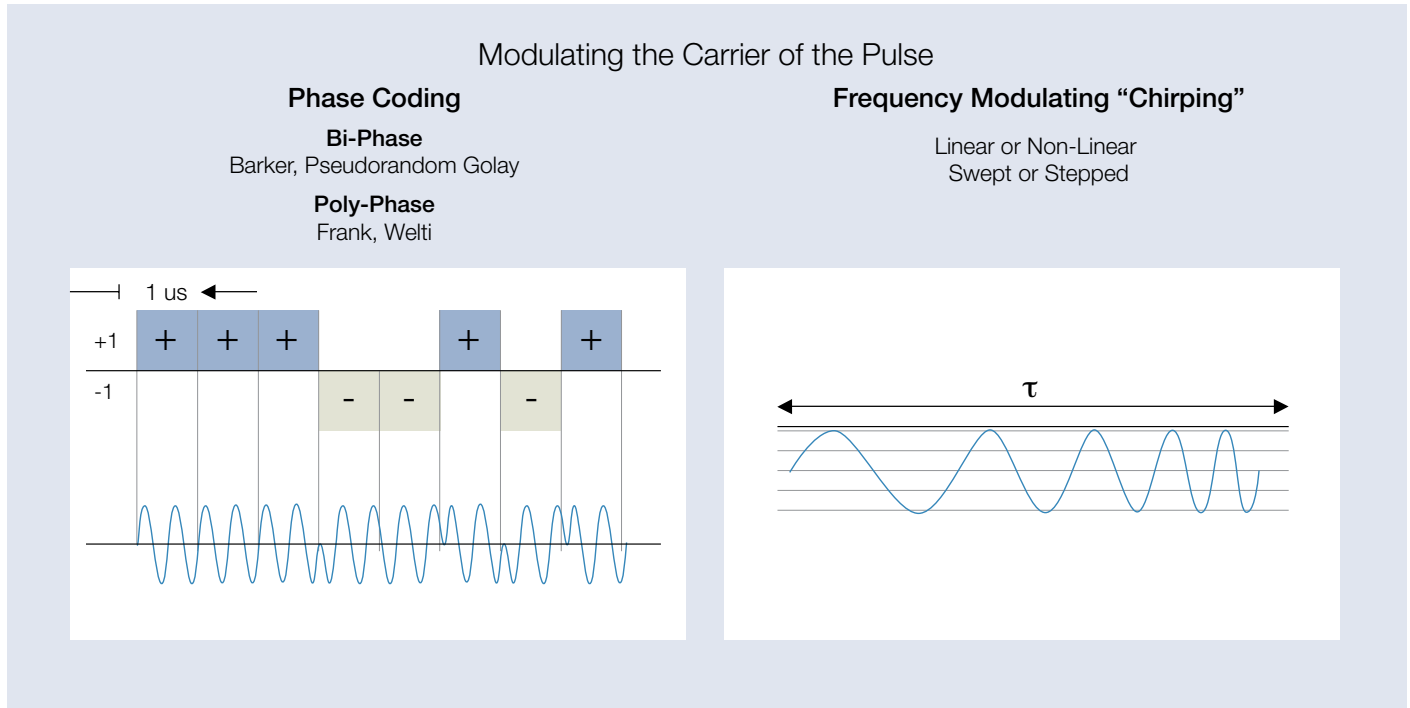

Figure 3. Methods of creating a pulse compression waveform.

Pulse Compression – the Solution to the Fundamental Challenge

So far we have seen there is a fundamental trade-off in radar system design; range versus resolution. As average transmitted power, and thus range, is increased by widening the pulse width, the resolution, the ability to detect targets which are close together, suffers. This situation exists in every radar system. Aircraft were used in Figure 2, but this would hold true regardless of the transceiver platform, (satellite, ground based, ship-borne, or hand-held) or the target (clouds, rain, missiles, or underground pipes).

The solution to this problem is what is known as pulse compression. Pulse compression is employed in most every radar system around the world regardless of type and location. The fundamental concept of pulse compression is that rather than simply transmitting a burst CW (unmodulated) signal, one of two parameters are changed over time. Either the phase, shown on the left side of Figure 3, or the frequency, shown on the right side of Figure 3, is changed.

In the case of phase modulation, the phase can be varied either between two states which are 180 degrees apart, known as Binary Phase Shift Keying or BPSK, or varied by a number of phase states, known as poly-phase. QPSK is one example of a poly-phase signal.

RF frequency of the pulse continuously changes over the pulse duration in a linear sweep

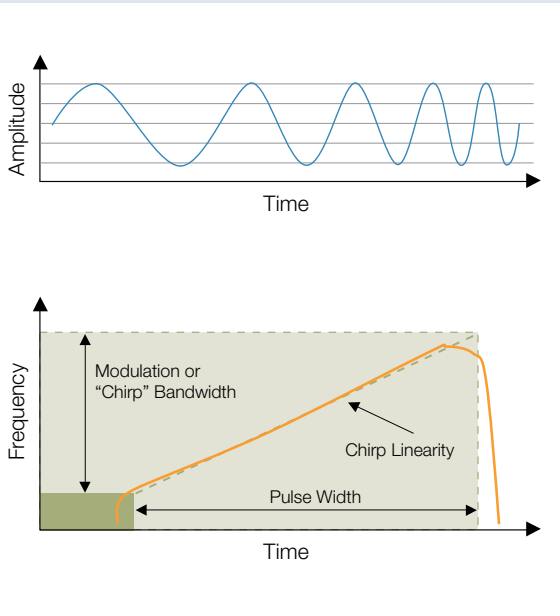

Figure 4. Illustration of a linear FM modulated signal where the RF frequency of the pulse continuously changes over the pulse duration.

```

clock = 10e9;           // AWG clock
fc = 1.25e9;           // Center frequency

pd = 4e-6;             // sweep period
fs = -4.5e6;           // starting frequency
fe = 4.5e6;            // ending frequency

len = pd * clock;
t = [0:len-1]/clock;

i = cos(2*pi*fs*t + 2*pi*(fe-fs)*(t^2)/2/pd);
q = sin(2*pi*fs*t + 2*pi*(fe-fs)*(t^2)/2/pd);

t = [0:len-1]/clock;
wfm = i .* cos(2*pi*fc*t) - q .* sin(2*pi*fc*t);
    
```

Figure 5. Sample MATLAB® to generate a linear FM modulated signal.

Linear FM, as illustrated in Figure 4, is one of the most common forms of pulse compression. Let's examine what happens when these types of modulated pulses are processed by the receiver. Such a signal could be generated using an arbitrary waveform generator (AWG) with the code shown in Figure 5.

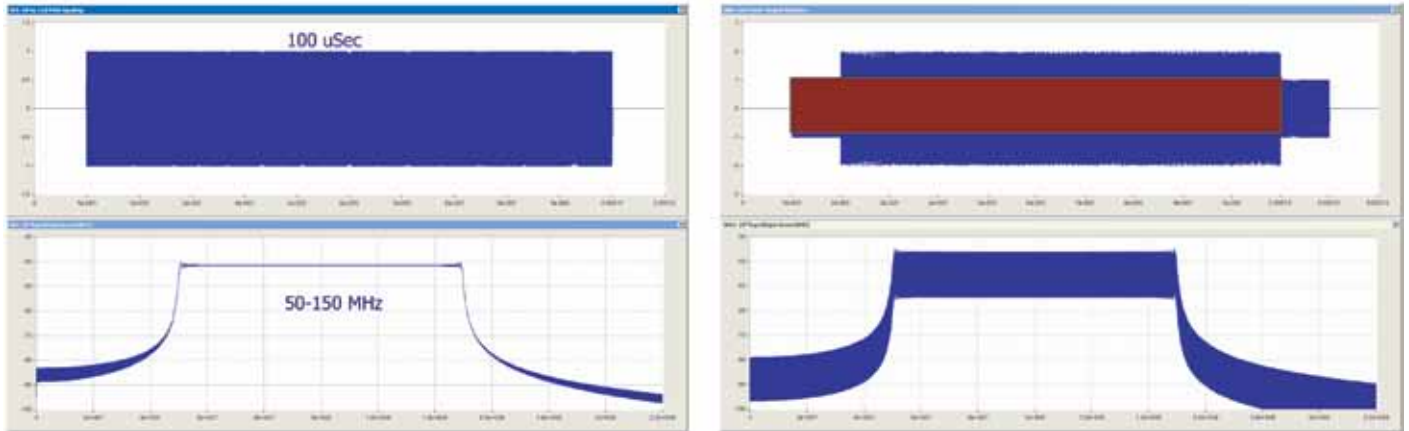

Figure 6. Transmitted LFM signal (left) versus returned signal with 2 targets (right): the brown area in the time domain view is where the target returns overlap.

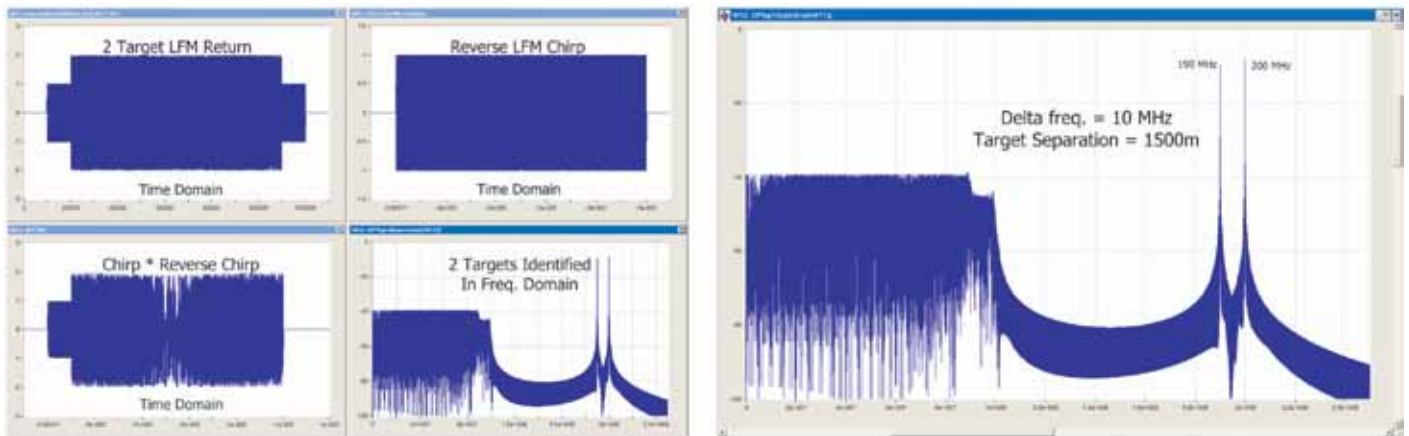

Figure 7. Results of an FFT on the chirp*reverse chirp product.

In Figure 6, an FFT is performed both on the 100usec LFM transmitted pulse and on the returned signal, which has some overlapping target returns in the time domain. This translates to a broader spectrum with more power spectral density but tells us nothing about the number of targets or their distance from one another. One of the techniques used to decode linear FM is called “stretch-radar” decoding. In this approach the returned signal is mixed with a reverse LFM signal and then an FFT is performed to convert the different returns into the frequency domain. Returns at different points in time (due to separation in distance) will be seen as separate frequencies. This is illustrated in Figure 7.

One benefit of the AWG offering two analog output channels is that this processing could be performed by simply having the AWG transmit a LFM signal from channel 1, while simultaneously transmitting the reverse LFM from channel 2

into the receiver or channel 2 of an oscilloscope, which mixes with the return signal (or is multiplied by using waveform math) before performing an FFT on the result.

There are also a number of benefits to using an AWG with a high sample rate and wide bandwidth when developing LFM signals. These will be covered later in this application note when covering stretch radar processing.

In the example in Figure 8, a 100us pulse is transmitted with 100MHz change in the transmitter frequency over the pulse duration. This is also known as modulation, or ‘chirp’, bandwidth. The first important factor to calculate is called the “time-bandwidth product” and is found by multiplying the pulse width and bandwidth, which in this case equals 10,000. This tells us that after pulse compression has been performed, we will have a 10,000:1 ratio of uncompressed to compressed pulse.

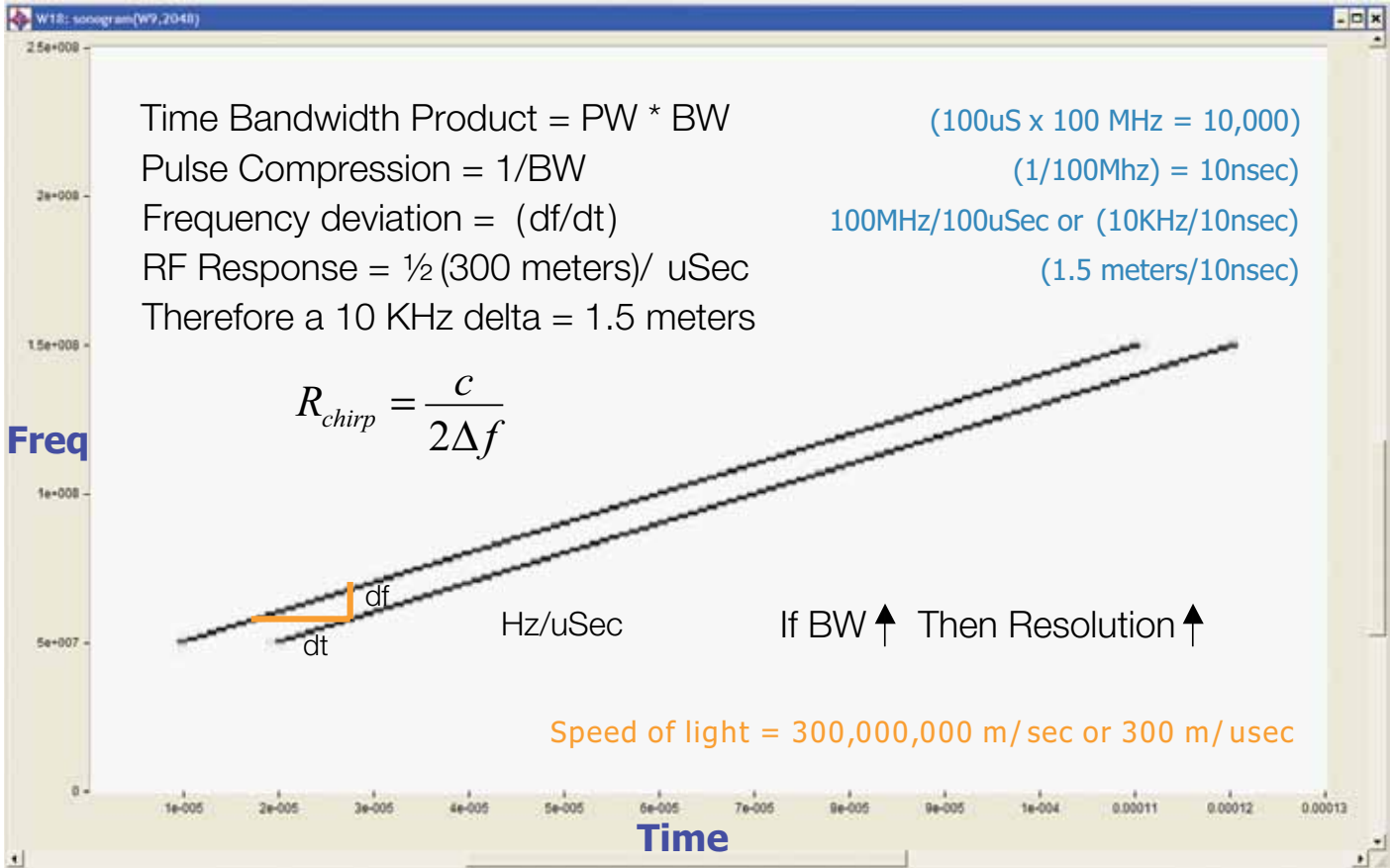

Figure 8. Spectrogram of two target returns from a LFM pulse signal.

The 100us transmitted pulse will offer the resolution of a 10nsec pulse. This can be confirmed by calculating the pulse compression, which is the inverse of the BW = 10nsec.

Next we calculate the rate of change (df/dt), which is 100MHz/100us or 10kHz/10nsec. We can correlate this to physical distance by knowing that the signal travels at the speed of light and that we are only interested in half of that value. We are seeing the result of the transmit and return time. Bringing everything into relative terms (150m/us = 1.5m/10ns=10 kHz) provides a way of relating the frequency difference measured on the FFT of the Chirp*Reverse Chirp signal to actual distance.

Bandwidth has a direct effect on the maximum resolution of a LFM as well as on non-linear FM. The minimum resolution can be calculated as shown in Figure 8. For a 100MHz bandwidth (Df = 100MHz) it is 1.5 meters. This means that targets must be separated by a minimum of 1.5 meters to be accurately measured using this bandwidth. Since the bandwidth product is in the denominator of the equation, we know that increasing its value will also increase the resolution.

Let's look at the signal range of this example. When the radar transmission is pulsed, the range of the target can be directly determined by measuring the time between the transmission of each pulse and the reception of the echo from the target. The round trip time is divided in half to calculate the time it took the signal to reach the target. This time, multiplied by the speed of light, is the distance to the target (for example R=ct/2). A useful rule of thumb is that 10us of round-trip transit time equals 1.5 kilometers of range, assuming there is sufficient transmit power. So the 100us pulse in our example allows for approximately 15 kilometers of range. Widening the pulse width would allow for a longer range, but would also require the extension of the bandwidth. Doubling the pulse width to 200us would require 200MHz of bandwidth, and so on.

$$\sigma_R = \frac{c}{2R\sqrt{2SNR}}$$

Equation 2. Bandwidth effect on range uncertainty.

The other affect of bandwidth is the uncertainty of the measured range. Equation 2 shows how bandwidth, along with signal-to-noise ratio, has a direct effect on range uncertainty.

For example, if the bandwidth (B) is 200 MHz and the SNR is 10dB, then the range accuracy is 0.167 meters. The measured range is within an accuracy window of ~0.17m. Many modern radars use hundreds of Megahertz or even many Gigahertz of bandwidth to allow for greater resolution and range. AWGs offers up to 9.6GHz of analog bandwidth to allow for LFM and other, even more complex, modulated pulses.

Along with the analog bandwidth needed to support wider frequency chirps, is the requirement for higher sample rate and more memory. Nyquist states that the sample rate needs to be a minimum of twice the highest frequency component. In reality, at least four times over-sampling is desired to improve signal quality. With a sample rate of up to 24GS/s, AWGs allow for direct generation of signals up to 6GHz without the use of an up-converter. For example, if a 1GHz frequency chirp is used, the AWG can sample at 10GS/s and create a pulse width of up to 6.4ms (64MS). Sequence memory can also be used to extend this to even longer duration of signals.

There are two fundamental drawbacks to a linear chip. One is that it does not allow for frequency shift of the returned pulse due to Doppler, which creates ranging errors. The other is that it creates time sidelobes, which can create false target returns (or “ghosts”) as well masking true returns.

One answer to allow for Doppler accuracy, the rate at which a target is moving toward or away from the transmitter, is to insert a constant frequency segment into the modulation cycle. This creates a ‘stepped’ frequency change as shown in Figure 9.

The overall accuracy of range in FM modulated pulses depends upon the steepness or rate of the transmitter frequency deviation, or df/dt as illustrated in Figure 8.

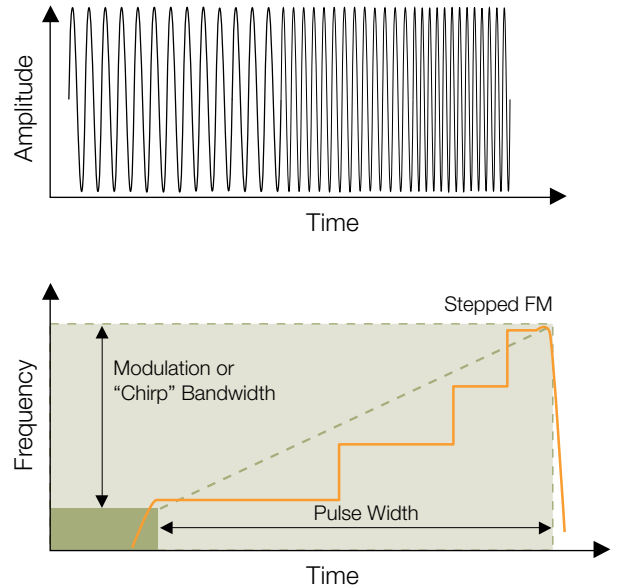

Figure 9. Stepped FM in which a CW component is added to the modulation cycle to allow for Doppler information.

The steeper this slope, the more accurately that target range can be determined. Generating steeper slopes with an AWG requires a faster sampling rate and more sample points in order to more precisely generate a highly linear chirp.

The resolution can be improved through the use of wider frequency bandwidth in a given pulse width, as this will increase the Time-Bandwidth product, allowing for greater pulse compression in the receiver. Generating wider frequency bandwidth modulation also requires a faster sample rate and wide analog bandwidth. By offering up to 24GS/s sample rate with 129.6M points of memory and bandwidth of 9GHz, the Tektronix AWGs allow for excellent FM modulation signals to be generated, thus improving both range and resolution.

Reducing False Returns and Increasing Probability of Detection

Recall from Equation 2 that the Signal-to-Noise ratio affects the uncertainty of the range measurement. Low SNR can also cause false returns and allow real targets to go undetected. The average transmitted power can be increased through use of wider pulses, increasing PRI, or increasing the peak power. The range equation shows that increasing the power of the transmitter by a given factor increases the detection range by only about the fourth root of that factor. Doubling the average transmitted power will only increase the detection range by about 19 percent. At the same time, the equation tells us that decreasing the mean level of the noise by a given factor has the effect of increasing the power by the same factor.

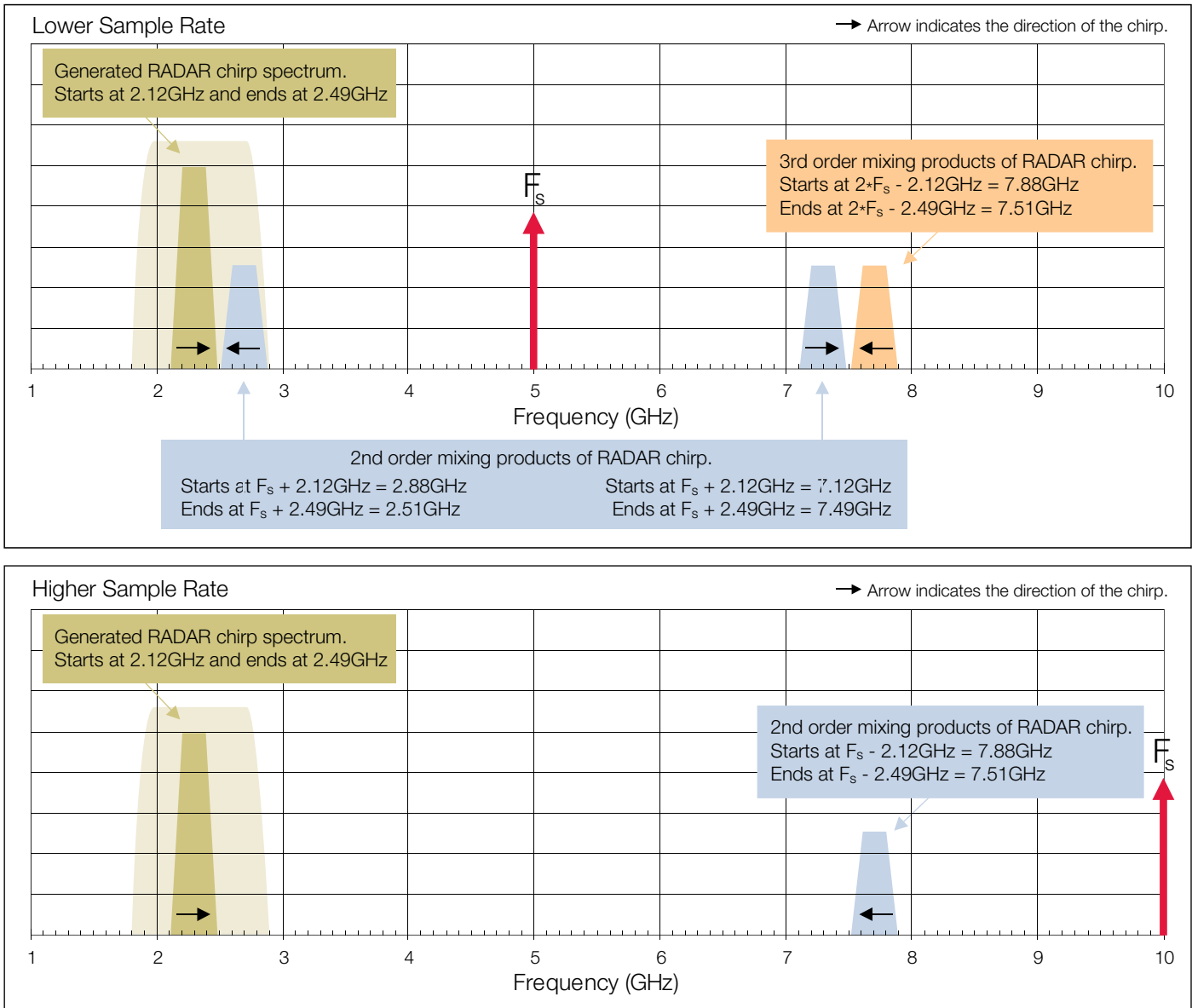

Figure 10. Spectral behavior when generating a LFM 'chirp' at lower sample rate (above) and higher sample rate (below). Note that 5GS/s still meets Nyquist minimum but allows images into the receiver pass-band (shown as a dotted line). Utilizing a 10GS/s sampling frequency moved the 2nd order image away from the receiver passband.

In addition to allowing for wide bandwidth and high direct generation, the high sample rate of the AWGs can be used to improve the signal to noise ratio (SNR). This is due to increasing the spectral placement of spurs such that they do not enter the receiver passband and by decreasing average noise. Let's look in more detail at how that is accomplished. As shown in the Figure 10, one clear advantage to over-sampling is moving the image/mixing products far outside the receiver passband. For an output signal at frequency F_{out} synthesized with a DAC updated at F_{clock} , images appear at $N \cdot F_{clock} \pm F_{out}$. The amplitude of these images rolls off with increasing frequency according to Equation 3, leaving "nulls" of very weak image energy around the integer multiples of the clock frequency.

$$\frac{\sin \pi(F_{out}/F_{clock})}{\pi(F_{out}/F_{clock})}$$

Equation 3. Amplitude of images vary according to this equation.

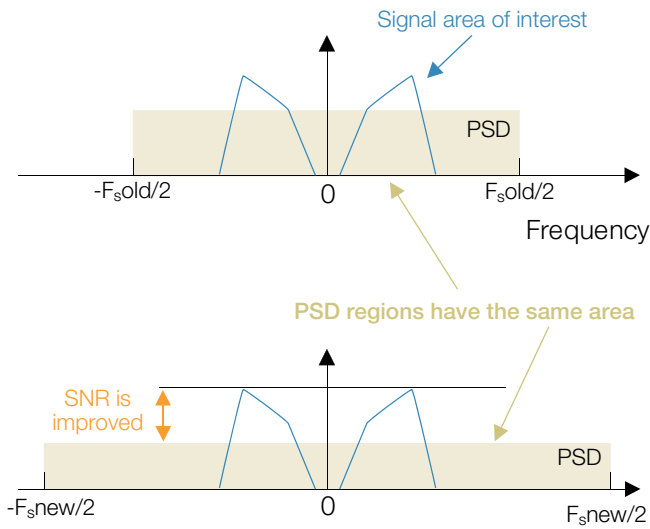

Figure 11. $PSD_{\text{noise}} = [(LSB \text{ value})^2/12](1/f_s) = (LSB \text{ value})^2/12f_s$.

Another advantage of the high sample rate of AWGs is over-sampling to reduce quantization noise. Over-sampling by a factor of 4, along with filtering, reduces the quantization noise by 1 bit (~6dB). Consequently, it is possible to achieve N+1-bit performance from an N-bit ADC, because signal amplitude resolution is gained when utilizing higher sampling speed. Figure 11 shows reducing Power Spectral Density (PSD) of the noise floor by spreading it across a wider spectral region.

AWGs offer 10 bit vertical resolution, which we have seen can be enhanced through the use of higher sampling to remove the effects of imaging products and reduce quantization noise.

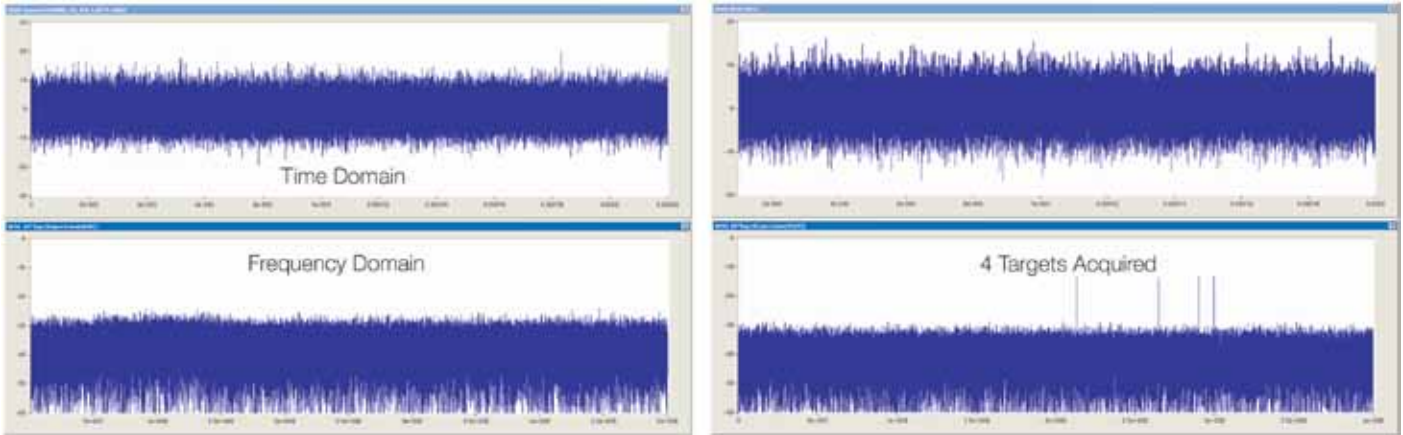

Figure 12. Unknown targets hidden in noise (left). Compression the power that was previously spread across a wider bandwidth so the signals (target returns) come out of the noise floor (right).

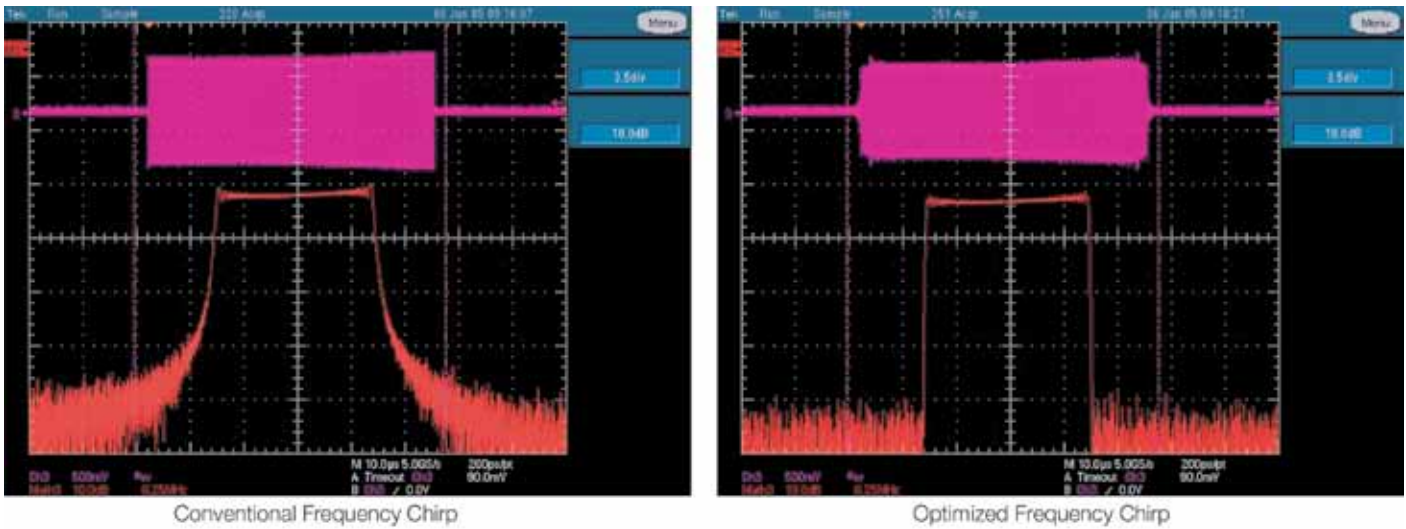

Figure 13. Use of windowing function to optimize frequency chirped pulses.

The matched filter will enhance the SNR, and as a result is able to detect chirp signals even when they are "buried" beneath the noise level.

Remote sensing systems, such as Synthetic Aperture Radar (SAR), usually apply FM signals to resolve nearly placed targets (objects) and improve SNR as shown in Figure 12.

As mentioned previously, one of the main drawbacks in the use of FM compression is that it can add range sidelobes in reflectivity measurements. Using weighting window processing in the time domain, it is possible to significantly decrease the sidelobe level (SLL) of output radar signals.

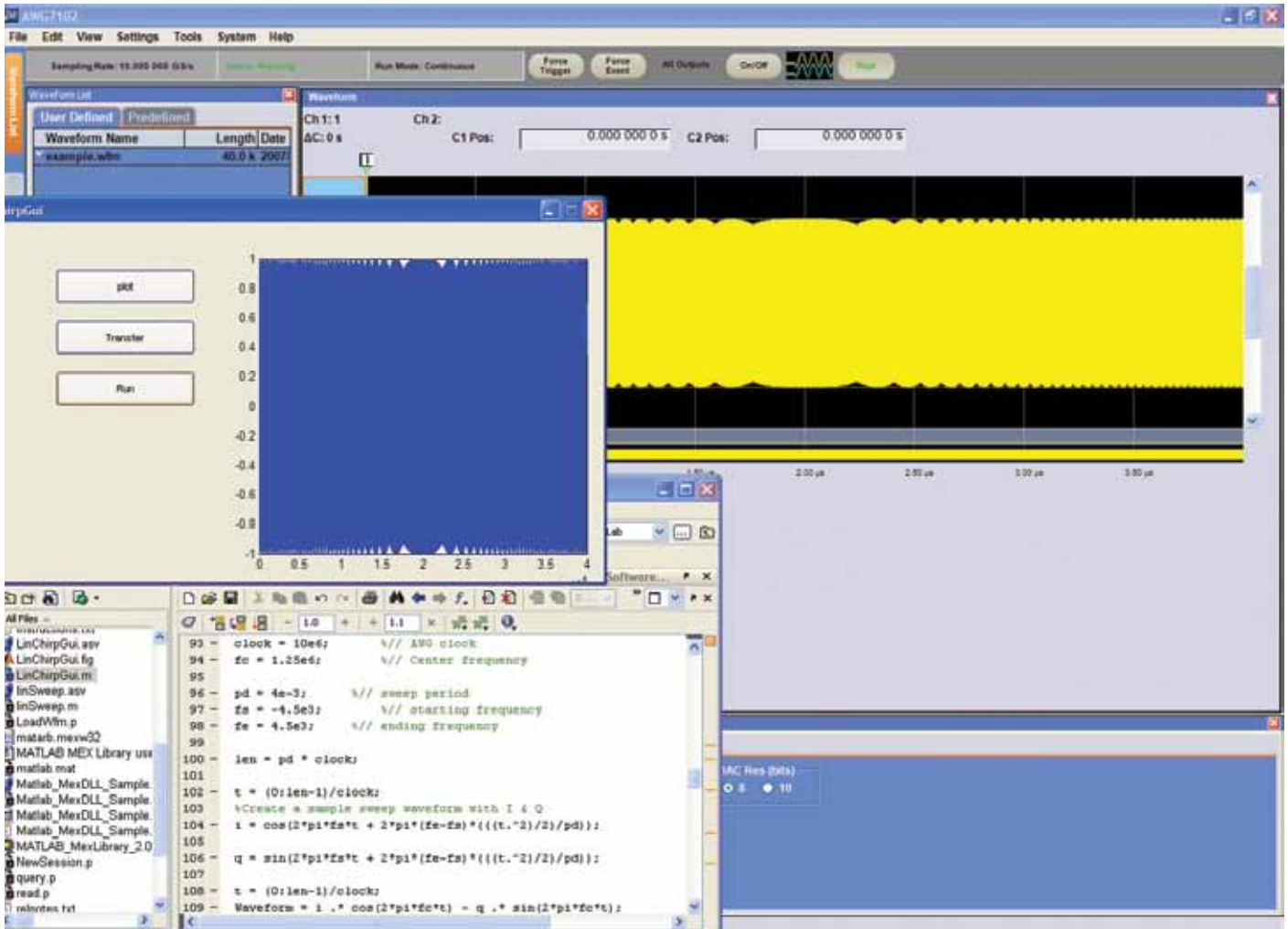

Figure 14. Using METLAB,® integration library to transfer a filtered chirp directly to the AWG.

Why not just use an FPGA test bench

Field programmable gate arrays (FPGAs) have wider potential than application-specific integrated circuits (ASICs) because they can be programmed in the field even after customer installation, allowing for future upgrades and enhancements. Typically, DSP designers are unfamiliar with FPGA design tools, and FPGA designers are unfamiliar with DSP algorithms. Building an FPGA test bench can be a time consuming exercise. Not only do all the components (power supplies, clock source, data converters, memory, etc.) need to be sourced, purchased, and assembled, but then the system must be fully characterized.

A user interface also needs to be written to allow for data transfer and parameter control. Use of an AWG allows for “known good” hardware and an existing GUI to be used so that the focus can be on algorithm development and transceiver chain optimization and troubleshooting. Once the DSP algorithms have been developed, they can be integrated into an FPGA implementation if desired.

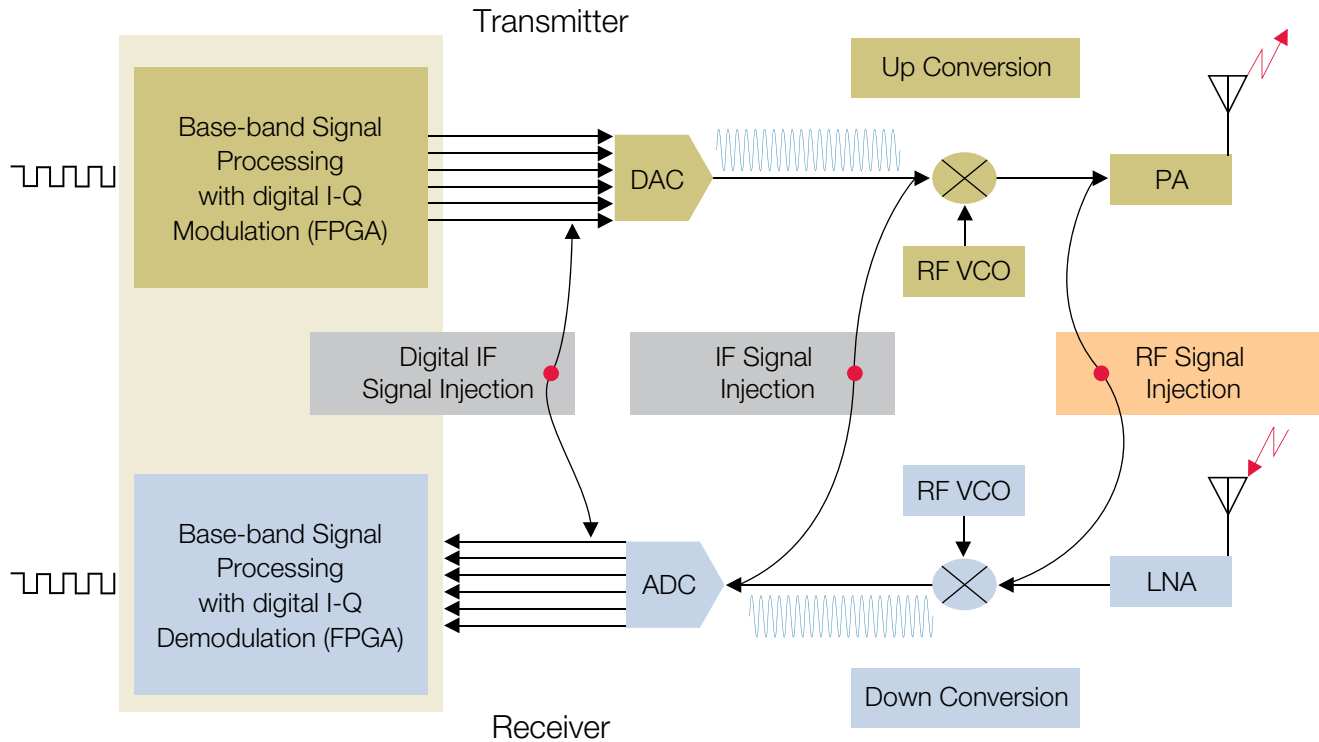

Figure 15. Signal injection at various stages of the digital transceiver chain.

Troubleshooting the Radar Transceiver Chain

More and more, modern radar systems are being implemented as digital (or software) defined radios. This is driving the need to test the radar transceiver chain at each stage, including digital IQ signal injection as seen in Figure 15.

Tektronix AWGs, specifically the AWG5000 Series, offer both analog and digital outputs, valuable for transceiver chain testing. The Tektronix AWG7000 Series is ideal for RF and IF signal generation. Both AWG Series offer multiple channel outputs which can be used to test the advanced implementation of antennas known as phased array which utilize beam-forming techniques.

When using phased antennas, it is important to delay signals at each antenna element by a precise amount so that the array's main lobe can be steered of bore sight. It is important to perform very precise and fast detection and tracking of targets with low reflected energy.

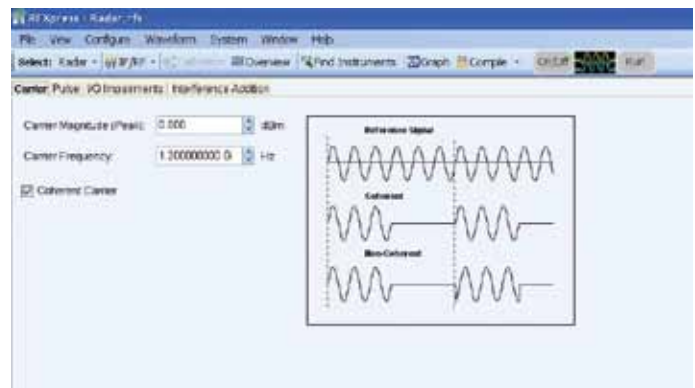

Figure 16. Waveform rotation on the Tektronix Arbitrary Waveform Generator.

This requires phase shifters in the system to produce minimum distortion. The AWG offers the ability to rotate the phase in increments as fine as 0.1 degree to allow for testing the receiver sensitivity to phase changes.

Introduction to RFXpress

RFXpress RFX100 is a software application that creates digitally modulated baseband, IQ, IF, RF, UWB-WiMedia, and Radar signals that can be generated through arbitrary waveform generators (AWG). This software runs as an integral part of AWG5000 and AWG7000 series arbitrary waveform generators and can also run from an external PC.

Using RFXpress RFX100 (referred to as RFXpress), you can define baseband I and Q signals with various modulation schemes and create single or multi-carrier signals where each carrier can be independently defined. For each carrier, you can apply impairments such as quadrature error and I/Q imbalance, add interferences such as sinusoidal interference, and define the graphs to create. Upon compilation, the signal can be viewed as graphs, sent to an arbitrary waveform generator, and saved for later use. Compilation options include sending signals directly to the AWG and completely eliminating the wrap-around effects found in arbitrary waveform generators. This provides seamless signals that can be played back continuously without any discontinuity or glitch in the time, frequency, modulation, or channel coding domains. Waveform transfer and control of the AWG5000 and AWG7000 series can be performed directly from RFXpress. RFXpress has several plug-ins that give users even more waveform generation capabilities. To date these include:

- Generic RF signals
- OFDM signals
- Radar pulses
- Environment additions
- UWB signals

Features of RFXpress

- Baseband data generation. Define baseband I and Q signals using a variety of modulation schemes such as No Mod, QPSK, Pi/2 QPSK, BPSK, Pi/4 QPSK, OQPSK, 8-PSK, O-8PSK, QAM-16, Pi/2 QAM16, QAM-32, QAM-64, QAM-128, QAM-256, QAM-512, QAM-1024, GMSK, 2-FSK, 4-FSK, 8-FSK, 16-FSK, 32-FSK, ASK, AM, PM, FM, nDPSK, OOK, and Pi/2 BPSK.
- Multi-carrier setup. Define multiple RF/IF carriers in a single waveform. Each carrier can be independently defined with parameters such as carrier frequency, symbol rate, modulation type, and baseband filters.
- Single or multiple pulse groups to form a pulse train. Each pulse group can be independently defined with various predefined pulse shapes and user defined shapes for a pulse group.
- Allows you to apply various modulation schemes or define your own.
- Allows you to have Pulse- to-Pulse hopping within a pulse group and to apply impairments like Edge Jitter, Width Jitter, Overshoot, Ripple and Droop on a pulse group.
- IQ impairments. Apply impairments including quadrature error and quadrature imbalance.
- Generate the following graphs:
 - Frequency Domain: Spectrum
 - I v Q: Constellation
 - Time Domain: I(t) and Q(t) versus time, and Pulse shape
 - Statistical: CCDF and Eye Diagram
 - Time versus Frequency: Spectrogram and Coherent Pulse Interval

- Distortion measurement for system calibration. To maintain system integrity and coherency with Amplitude, Phase inband flatness, and skew between separate channels. The setup includes capturing data from a TDS oscilloscope and a real-time spectrum analyzer and downloading the data to generate the correction data.
- Noise/interference generation and addition. Generate and add interference for waveforms. Generate gated noise on specific frames designated by the user.
- Capture and Replay. Waveforms captured from oscilloscopes and real-time spectrum analyzers can be modified in RFXpress before they are regenerated.
- Wrap around. RFXpress completely eliminates all the wrap-around effects found in arbitrary waveform generators, providing seamless signals that can be played back continuously without any discontinuity or glitch in the time, frequency, modulation, or channel coding domains.
- Connectivity between AWG, oscilloscope, and Agilent Performance Signal Generator® (PSG). The ability to identify and connect to a Tektronix Arbitrary Signal Generator (AWG), a Tektronix oscilloscope, and the Agilent PSG®, and to configure their setups remotely. The radar application uses the AWG sequence mode is to optimize the memory and create large number of pulses. However if Option 08 is not purchased, the radar application uses the Continuous Mode instead of Sequence Mode.
- Remotely configure a Tektronix real-time spectrum analyzer and import I and Q trace data.
- Characterize a DUT and provide S-parameter emulation of RF components.
- Define antenna beam profile and simulate target returns for radar signals.
- Create multiple layers of modulation using subcarrier multiplexing.
- Define a staggered PRI with ramp and user-defined profiles, and add up to ten multipaths.
- Configure all parameters of OFDM
- Build custom OFDM frames from defining base data, symbols, packets, and frames
- Support Reed Solomon, Convolution coding, and Scrambling
- Add Impairments Phase noise, Multipath, and Quantization
- Define frequency hopping and gated noise
- Support a variety of subcarrier modulation (BPSK, QPSK, QAM (16,32,64,256) and 8-PSK)
- Support Tone Nulling and Clipping
- Provide presets for WiFi and WiMax standards

Note on RFXpress

RF signals are becoming more and more complex, making the job of RF engineers, who need to accurately validate and margin test their designs, more difficult. To solve this design challenge, Tektronix' RFXpress software delivers advanced RF/IF/IQ creation and editing tools.

RFXpress is a software package to synthesize digitally modulated baseband, IF and RF signals. It takes IQ, IF and RF signal generation to the next level and fully exploits the wideband signal generation capabilities of Tektronix arbitrary waveform generators (AWGs).

Radar signal creation using Option RDR, a software module for RFXpress, gives you the ultimate flexibility in creating Pulsed Radar waveforms. It gives you the ability to build your own Radar pulse suite starting from pulse to pulse trains to pulse groups. It supports a variety of Modulation schemes including LFM, Barker and Poly phase Codes, User defined codes, Step FM, Non-Linear FM, User Defined FM and Custom modulation. It also has the ability to generate pulse trains with staggered PRI to resolve: Range and Doppler ambiguity, Frequency Hopping for Electronic Counter Counter Measures (ECCM), and Pulse-to-Pulse Amplitude variation to simulate Swerling target models.

RFXpress also has a unique feature included in option RDR that allows users to create radar signals with environmental interferences.

This waveform generation technique is part of the growing requirement to test radar receiver equipment for interference from the wide variety of wireless applications flooding the airways. Some of the radar applications that are susceptible to these interference signals include:

- Short and Long range air traffic control
- Fixed ground-based weather surveillance
- Airborne weather surveillance
- Maritime navigation and surface search
- Electronic Warfare Systems
- Wireless spectrum Management

Radar frequency bands and their usage

Band	Frequency	Wavelength	Application
HF	3-30 MHz	10-100 m	Coastal radar systems, over-the-horizon (OTH) radars; 'high frequency'
P	< 300 MHz	1 m+	'P' for 'previous', applied retrospectively to early radar systems
UHF	300-1000 MHz	0.3-1 m	Very long range (e.g. ballistic missile early warning), ground penetrating, foliage penetrating; 'ultra high frequency'
L	1-2 GHz	15-30 cm	Long range air traffic control and surveillance; 'L' for 'long'
S	2-4 GHz	7.5-15 cm	Terminal air traffic control, long-range weather, marine radar; 'S' for 'short'
C	4-8 GHz	3.75-7.5 cm	Satellite transponders; a compromise (hence 'C') between X and S bands; weather radar
X	8-12 GHz	2.5-3.75 cm	Missile guidance, marine radar, weather, medium-resolution mapping and ground surveillance; in the USA the narrow range 10.525 GHz \pm 25 MHz is used for airport radar. Named X band because the frequency was kept secret during WWII

The AWG7000 series with its 24GS/s sample rate DAC architecture has the capability to produce direct RF frequencies up to 9.6 GHz and it affords engineers the capability to test many receivers without the requirement for up-converters.

Radar Interference Testing using Tektronix AWG 5000/7000 series and RFXpress Environment Signal Creation software

Application Introduction

Arbitrary Waveform Generators (AWGs) are one of the most versatile and useful test and measurement products used today. With an AWG users can create real world signals that enable engineers to re-create anomalies and test signals that are difficult or impossible to re-produce. AWGs can also be used to mimic environments that enable engineers to test complex scenarios that would require multiple test benches filled with equipment or costly live interactions with other electronic devices. One of the features available with an AWG and RFXpress software is what is called Environment Signal Creation. This RF waveform generation technique is part of the growing requirement to test receiver equipment for interference from the wide variety of wireless applications flooding the airways. Specifically some radar applications that are susceptible to these interference signals include:

- Short and Long range air traffic control
- Fixed ground-based weather surveillance
- Airborne weather surveillance
- Maritime navigation and surface search
- Electronic Warfare Systems
- Wireless spectrum Management

Why do we need to do interference testing for radar specifically? Radar systems have historically been allocated in bands where they do not share with communication systems. But in recent years, proposals have been made and granted for communication systems to operate in radar bands. These include:

- Radio local area networks (RLANS)
- Satellite Signals
- Various new mobile radio systems including WiMax

In 2002 NTIA (National Telecommunications and Information Administration) which is an agency that is part of the Department of Commerce and responsible for federal spectrum use, started a study on Interference Effects and Interference - Limit Criteria for Radar Receivers. The report was completed in July of 2010 and some of the findings were quite alarming.

The radar types that were measured as part of this study were:

- Several maritime radars in S and X-bands (in both the US and the UK)
- Airport surveillance radars in S-band
- Airborne weather surveillance radar in X-band
- Airport surface detection radar in X-band
- Precision approach radar in X-band
- Wind profiler radar in UHF

The Summary of the results includes:

- Interference at high duty cycles (above about 2%), such as from communication signals, typically causes target losses to begin at I/N levels between -10 to -6 dB
- Target losses due to low levels of interference are insidious because no visible effects are associated with the interference. The targets simply fade away
- Target losses can occur at any range. Losses do not just occur at the edge of radar coverage, but rather anywhere that the targets are close to radar receiver noise

With these results now published and available at: <http://www.its.bldrdoc.gov/pub/ntia-rpt/06-444/> many radar facilities are requiring testing of their receivers to find out how susceptible their systems are to these interference signals. These tests can require multiple racks of test equipment in order to create these types of interference signals. But with an Arbitrary Waveform Generator (AWG) along with some specific software (RFXpress) these signals can be simulated very effectively and they can also include the interference that allows for complete testing of the radar receivers and their susceptibility.

RFXpress with the Environment Radar plug-in allows users to create their own environment such as:

- Defining up to 25 signals that add up to your complete stressed environment
- Direct support for WiMAX, WiFi, GSM, CDMA, W-CDMA, DVB-T, Noise & CW Radar
- Seamlessly integrate other signals from RFXpress plug-ins in to the environment
- Add Noise to the environment

RFXpress also allows users to configure the signal's parameters such as:

- Configure PHY parameters of your signals
- Control Carrier frequency, Power, Start time and Duration for all the signals in the environment
- Capture / Import signals from Real Time Spectrum Analyzer (RTSA), Scope or MATLAB

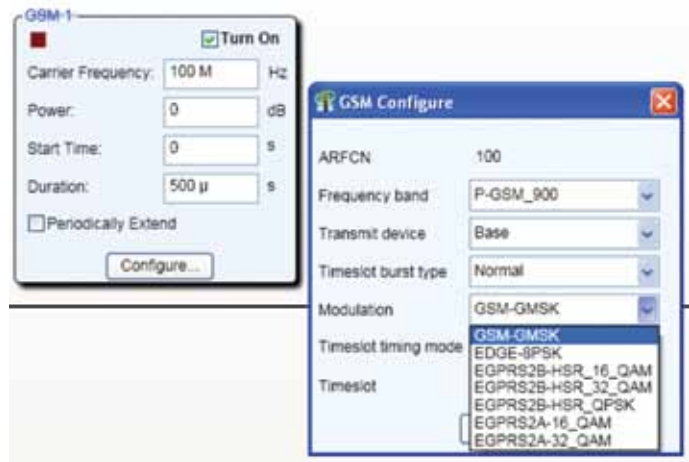

For this note we will build a radar test scenario using RFXpress to show how easy this interference testing can be accomplished.



Starting with RFXpress

1. First we want to select Environment as the signal type.

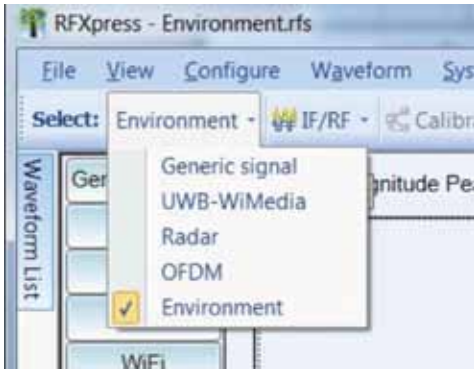

2. Next we will select the output type; in this case we will be using the AWG in direct IF/Rf single channel mode.

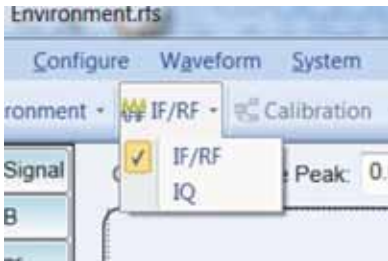

3. In the Environment window we will use Radar as our primary signal, to do this just drag and drop Radar into the Environment signal box.

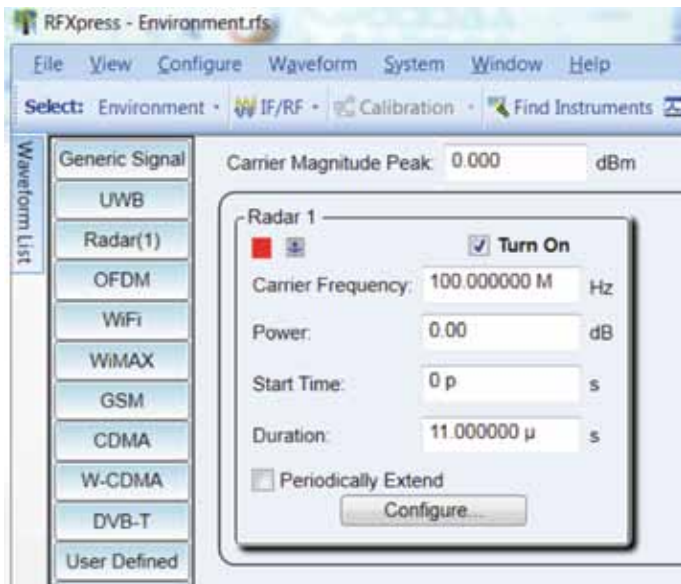

4. Next we need to set the parameters in the Radar 1 fields for our specific signal characteristics. For this example we will create a Pulse-to-Pulse Frequency Hopping signal.

5. To configure the Radar parameters we will select the Configure button and then Advanced to get to the detailed Radar configuration menu.

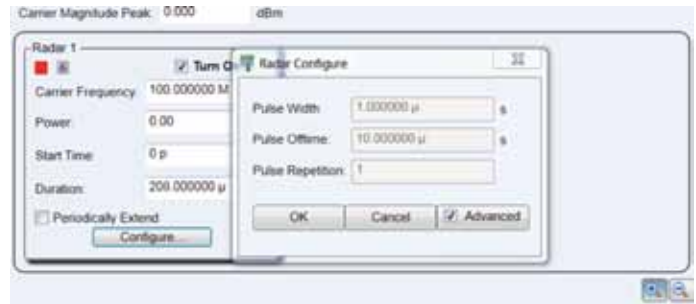

6. We will set the amplitude to 2.5dB Peak and carrier frequency to 200MHz.

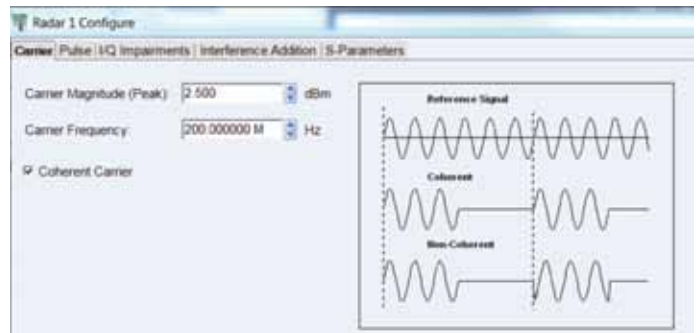

Application Note

7. Next select the Pulse Tab and the Pulse Envelope Tab and configure as such:

- Pulse Shape to Raised Cosine.
- Start Time to 0 ps (default).
- Rise Time to 0.1 μ s at 20–80%.
- Pulse Width to 15 μ s at 50%.
- Fall Time to 0.1 μ s at 20–80%.
- Off Time to 30 μ s.
- Amplitude Relative to Carrier to 0 dB (default).
- Offset from Carrier Frequency to 0 Hz (default).
- Repeat to 6.

NOTE. The PRF and PRI values are calculated and automatically updated based on the parameters that you just set. In this case, the PRF is 22.102 KHz and the PRI (in the table) is 0.0452 ms



8. Select the Modulation tab and select Modulation to No Modulation.

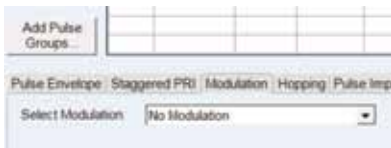

9. Select the Hopping tab and select Turn on.

10. In the table, select Add to add rows.

11. Set the following:

- Frequency Offset for the first hop to 50 MHz.
- Frequency Offset for the second hop to 40 MHz.
- Frequency Offset for the third hop to -50 MHz.
- Frequency Offset for the fourth hop to 0 MHz.
- Frequency Offset for the fifth hop to 30 MHz.
- Frequency Offset for the sixth hop to -30 MHz.

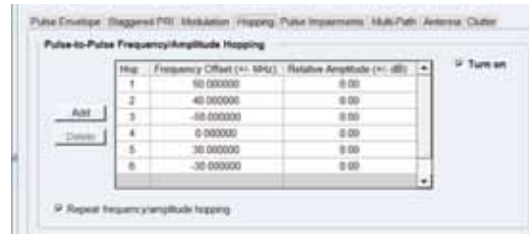

12. Select OK and OK to complete the radar 1 configuration

This is just one example of the many RF applications that can be tested using this and other techniques available with an AWG and RFXpress software.

In Conclusion; RFXpress and the Environment plug in along with the AWG7000 series allow for robust Radar receiver testing enabling confidence in Radar system performance.

Creating Polyphase coded (Frank code) Radar waveform using RFXpress

Radars strive for better range resolution coupled with improved detection capability.

Radars required high SNR or higher transmitted power to have higher detection capability. This would be accomplished by larger pulse width. But for better range resolution we need greater bandwidth, which is equal to 1/Pulsewidth. This means that improving resolution requires a shorter pulse, while improving detection performance requires a longer pulse. Thus detection and range resolution in a simple, constant-frequency pulsed waveform (No-modulation in RFXpress), conflict with each other.

Pulse Compression is a technique which decouples the above two parameters. This is done by abandoning the constant frequency modulation (No modulation) and instead adding frequency and phase modulation to a simple pulse. Pulse compression waveforms include Frequency modulated (Linear Frequency modulation Pulse compression, Stepped Frequency modulation, etc.) and Phase modulated Pulse compression (Biphase codes, Polyphases codes etc.).

In Frequency Modulation the frequency within the pulse is either swept with a known rate (LFM) or hopped between known frequency offsets (Costas codes).

In Phase Modulated (Phase coded) waveforms the RF frequency remains constant but an absolute phase is switched between some N fixed values at regular interval. Thus the entire pulse width is divided into N subpulse (or chips), each with same frequency but different phases. Phases code can be divided into two types, Biphase and Polyphase codes. In Biphase codes, the phase of the subpulse can be either 0 or 180 degrees. Example of Biphase codes are the Barker codes. In Polyphase codes, the phase of the subpulse can take arbitrary values. Polyphase codes have advantage over Biphase codes that they exhibit lower side lobes.

Frank Codes

Frank code is a type of Polyphase codes wherein the codes are harmonically related phases based on a certain fundamental increment.

Frank Codes provide very good resistance to Doppler shift. In the ambiguity function the main lobe amplitude remains greater than the side lobes with majority of the Doppler shifts in contrast to Bi-phase coded pulses where the mainlobe amplitudes reduces with the increasing Doppler shifts.

Frank code of length N has N^2 code defined. The number of subpulse is equal to N^2 , thus limiting the number of subpulses to be always a perfect square.

In this scheme a single pulse width (T_{on}) is divided into N^2 subpulses each of width T_{on}/N^2 . Thus this type of a modulation scheme has a compression ration of N^2 .

Phases in each of the subpulses will be constant and changes from one subpulse to another based on the fundamental phase offset which is obtained by following equation:

$$\Delta\theta = 360/N \text{ degrees}$$

Equation 4.

Phases for each of the subpulse can be obtained as

$$\theta_n = (2 \times (p \times q)/N) \times 180$$

$$p = 0, 1, 2, \dots, N-1$$

$$q = 0, 1, 2, \dots, N-1;$$

Equation 5.

Frank phase values are obtained from the below Frank Matrix and fundamental phase offset

$$\begin{pmatrix} 0 & 0 & 0 & 0 & \dots & 0 \\ 0 & 1 & 2 & 3 & \dots & N-1 \\ 0 & 2 & 4 & 6 & \dots & 2(N-1) \\ \dots & \dots & \dots & \dots & \dots & \dots \\ 0 & N-1 & 2(N-1) & 3(N-1) & \dots & (N-1)^2 \end{pmatrix} \Delta\theta$$

Equation 6.

The Frank codes are then obtained by concatenating the rows of the Frank Matrix

Creating a Frank Code of Length 4

Let us now create Frank Code of length 4.

The fundamental phase increment is:

$$\Delta\theta = 360/4 = 90 \text{ degrees}$$

Equation 7.

The phase codes for each of the subpulses from the Frank Matrix would be:

$$\begin{pmatrix} 0 & 0 & 0 & 0 \\ 0 & 1 & 2 & 3 \\ 0 & 2 & 4 & 6 \\ 0 & 3 & 6 & 9 \end{pmatrix} \times 90^\circ$$

$$= \begin{pmatrix} 0 & 0 & 0 & 0 \\ 0 & 90^\circ & 180^\circ & 270^\circ \\ 0 & 180^\circ & 0 & 180^\circ \\ 0 & 270^\circ & 180^\circ & 90^\circ \end{pmatrix}$$

Equation 8.

Concatenating the rows of the above Matrix, the phase for each subpulse is:

$$\theta_n = [0 \ 0 \ 0 \ 0 \ 0 \ 90^\circ \ 180^\circ \ 270^\circ \ 0 \ 180^\circ \ 0 \ 270^\circ \ 180^\circ \ 90^\circ]$$

Equation 9.

The above phase can be wrapped between +180 degrees and -180 degrees as:

$$\theta_n = [0 \ 0 \ 0 \ 0 \ 0 \ 90^\circ \ 180^\circ \ -90^\circ \ 0 \ 180^\circ \ 0 \ 180^\circ \ 0 \ -90^\circ \ 180^\circ \ 90^\circ]$$

Equation 10.

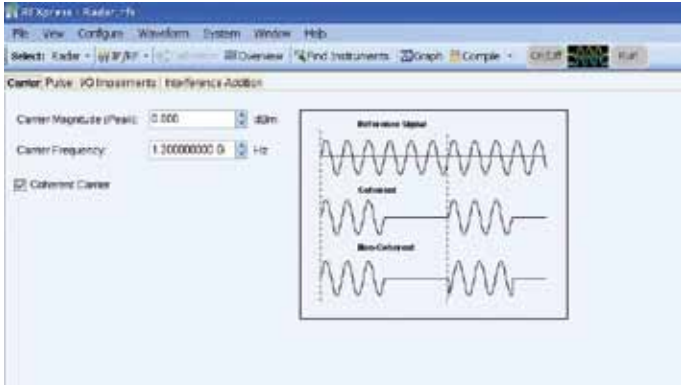

Figure 17. Setting a carrier frequency in RFXpress.

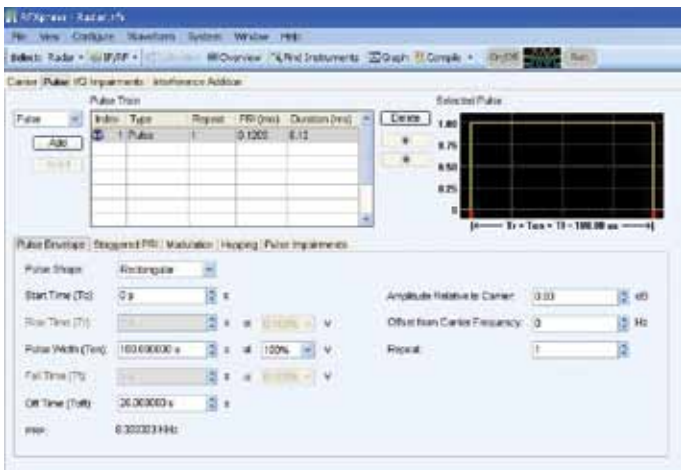

Figure 18. Defining the Pulse parameters in the Pulse Envelope Tab in RFXpress.

Creating a Frank Coded Waveform Using RFXpress

We will now create the Frank coded as define above. RFXpress Radar plug-in provides for generation of different types of pulses, RF/IF frequencies, modulation etc.

After we invoke the Radar plugin in RFXpress, we set the carrier frequency and the magnitude in the carrier tab as shown in the figure above.

Next the pulse type and the pulse width, offtime, rise time fall time can be set in the Pulse envelop tab. We will take a rectangular pulse with pulse width of 100usec and offtime of 20usec which will result in a PRI of 8.333Khz as shown in Figure 18.

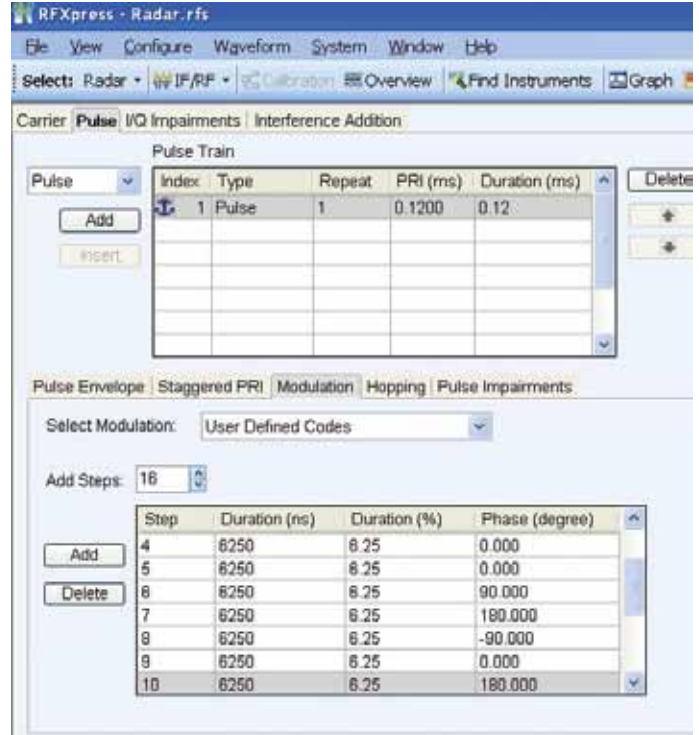

Figure 19. A[n 0 e x0a m Op l e0 o f0 u s9in0g° t h1e8 "0U°s e 2r 7D0e°fin e0d C18od0e°s °0 t o 2 d7e0fin° e 1a8 F0ra°n n9k0 C° o]de.

Now to set Phase modulation to the pulse, in the Modulation tab, select 'User Defined Codes'. This feature provides flexibility to the user to define arbitrary number of subpulses (by setting "Add steps") and setting arbitrary phases to each of the subpulse.

We will use User defined codes to define Frank Code of length 4. As we have Frank code of length 4, the number of subpulses would be 16.

Add 16 steps and enter the phases as per the Frank Matrix derived above.

$$\Theta_n = [0 \ 0 \ 0 \ 0 \ 0 \ 90^\circ \ 180^\circ \ -90^\circ \ 0 \ 180^\circ \ 0 \ 180^\circ \ 0 \ -90^\circ \ 180^\circ \ 90^\circ]$$

Equation 11.

Now we can compile the waveform to create a Polyphase coded waveform.

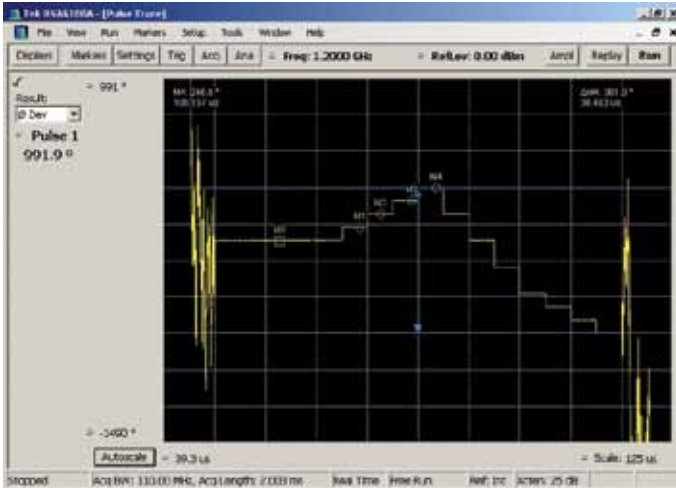

Figure 20. A snap shot of Pulse parameter as seen in the RTSA.

Verification

RSA6100 series with Pulse analysis software can be used to verify the created waveform.

Figure 20 shows the Pulse parameters and the spectrum of the created waveform.

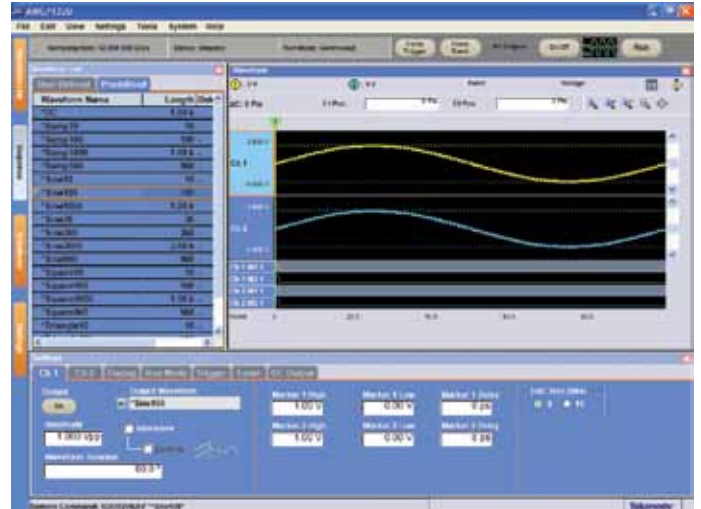

Figure 21. Snap shot of the ϕ deviation with in the pulse as seen in the RTSA.

Phase deviation within the Pulse can be viewed in the Pulse trace display shown in Figure 21.

Summary

Generating advanced radar signals often demands exceptional performance from an arbitrary waveform generator (AWG) in terms of sample rate, analog bandwidth, and memory.

The Tektronix AWG7000 Series sets a new industry standard for advanced radar signal generation, by delivering an exceptional combination of high sample rate, wide analog bandwidth, and deep memory. With a sample rate of up to 24Gs/s and 9GHz analog bandwidth, the AWG7000 Series can directly generate RF signals never before possible from an AWG. In instances where IQ generation is desired, the AWG7000 offers the ability to over-sample the signal, thereby improving signal quality. An internal, variable clock is utilized, thereby eliminating the cost and complexity of using an external clock source.

Advanced radar systems are also becoming more software defined, whereby more functionality is being handled in the digital baseband domain. Tektronix' AWG5000B Series offers 28 digital signal outputs as well as up to four analog outputs with 14 bits of vertical resolution for challenging dynamic range requirements. This combination allows for signal generation in a truly "mixed signal" environment.

RFXpress software with Radar plug-in fully utilizes the wide band capabilities of the AWG providing ultimate flexibility to create complicated Pulsed Radar waveform.

References and Acknowledgments

Tektronix application note: "How to Create Direct Synthesis Signals Using Arbitrary Waveform Generators", available at www.tektronix.com/signal_generators.

The author wishes to thank the following organization for their contribution to this document: - X-COM Systems, a Tektronix value added reseller (VAR).

The author wishes to acknowledge the following authors and their books:

Radar Systems Analysis & Design Using MATLAB

by Bassem R Mahafza

Fundamentals of Radar Signal Processing

by Mark A Richards.

Contact Tektronix:

- ASEAN / Australasia (65) 6356 3900
- Austria* 00800 2255 4835
- Balkans, Israel, South Africa and other ISE Countries +41 52 675 3777
- Belgium* 00800 2255 4835
- Brazil +55 (11) 3759 7627
- Canada 1 (800) 833-9200
- Central East Europe and the Baltics +41 52 675 3777
- Central Europe & Greece +41 52 675 3777
- Denmark +45 80 88 1401
- Finland +41 52 675 3777
- France* 00800 2255 4835
- Germany* 00800 2255 4835
- Hong Kong 400-820-5835
- India 000-800-650-1835
- Italy* 00800 2255 4835
- Japan 81 (3) 6714-3010
- Luxembourg +41 52 675 3777
- Mexico, Central/South America & Caribbean 52 (55) 56 04 50 90
- Middle East, Asia and North Africa +41 52 675 3777
- The Netherlands* 00800 2255 4835
- Norway 800 16098
- People's Republic of China 400-820-5835
- Poland +41 52 675 3777
- Portugal 80 08 12370
- Republic of Korea 001-800-8255-2835
- Russia & CIS +7 (495) 7484900
- South Africa +27 11 206 8360
- Spain* 00800 2255 4835
- Sweden* 00800 2255 4835
- Switzerland* 00800 2255 4835
- Taiwan 886 (2) 2722-9622
- United Kingdom & Ireland* 00800 2255 4835
- USA 1 (800) 833-9200

*** If the European phone number above is not accessible,
please call +41 52 675 3777**

Contact List Updated 10 February 2011

For Further Information

Tektronix maintains a comprehensive, constantly expanding collection of application notes, technical briefs and other resources to help engineers working on the cutting edge of technology. Please visit www.tektronix.com



Copyright © 2012, Tektronix. All rights reserved. Tektronix products are covered by U.S. and foreign patents, issued and pending. Information in this publication supersedes that in all previously published material. Specification and price change privileges reserved. TEKTRONIX and TEK are registered trademarks of Tektronix, Inc. All other trade names referenced are the service marks, trademarks or registered trademarks of their respective companies.

05/12 EA/FCA-POD

76W-20730-3

Tektronix[®]

