

**WVR6020, WVR7020, WVR7120,  
WVR6100 Opt. MB, WVR7000 Opt. MB, and  
WVR7100 Opt. MB Waveform Rasterizers, and  
WVRRFP Remote Front Panel  
Service Manual**



077-2235-00

**Tektronix**



**WVR6020, WVR7020, WVR7120,  
WVR6100 Opt. MB, WVR7000 Opt. MB, and  
WVR7100 Opt. MB Waveform Rasterizers, and  
WVRRFP Remote Front Panel**

**Service Manual**

Revision A

[www.tektronix.com](http://www.tektronix.com)

077-2235-00

**Tektronix**

Copyright © Tektronix. All rights reserved. Licensed software products are owned by Tektronix or its subsidiaries or suppliers, and are protected by national copyright laws and international treaty provisions.

Tektronix products are covered by U.S. and foreign patents, issued and pending. Information in this publication supersedes that in all previously published material. Specifications and price change privileges reserved.

TEKTRONIX and TEK are registered trademarks of Tektronix, Inc.

## **Contacting Tektronix**

Tektronix, Inc.  
14200 SW Karl Braun Drive  
P.O. Box 500  
Beaverton, OR 97077  
USA

For product information, sales, service, and technical support:

- In North America, call 1-800-833-9200.
- Worldwide, visit [www.tektronix.com](http://www.tektronix.com) to find contacts in your area.

## Warranty

Tektronix warrants that this product will be free from defects in materials and workmanship for a period of one (1) year from the date of shipment. If any such product proves defective during this warranty period, Tektronix, at its option, either will repair the defective product without charge for parts and labor, or will provide a replacement in exchange for the defective product. Parts, modules and replacement products used by Tektronix for warranty work may be new or reconditioned to like new performance. All replaced parts, modules and products become the property of Tektronix.

In order to obtain service under this warranty, Customer must notify Tektronix of the defect before the expiration of the warranty period and make suitable arrangements for the performance of service. Customer shall be responsible for packaging and shipping the defective product to the service center designated by Tektronix, with shipping charges prepaid. Tektronix shall pay for the return of the product to Customer if the shipment is to a location within the country in which the Tektronix service center is located. Customer shall be responsible for paying all shipping charges, duties, taxes, and any other charges for products returned to any other locations.

This warranty shall not apply to any defect, failure or damage caused by improper use or improper or inadequate maintenance and care. Tektronix shall not be obligated to furnish service under this warranty a) to repair damage resulting from attempts by personnel other than Tektronix representatives to install, repair or service the product; b) to repair damage resulting from improper use or connection to incompatible equipment; c) to repair any damage or malfunction caused by the use of non-Tektronix supplies; or d) to service a product that has been modified or integrated with other products when the effect of such modification or integration increases the time or difficulty of servicing the product.

THIS WARRANTY IS GIVEN BY TEKTRONIX WITH RESPECT TO THE PRODUCT IN LIEU OF ANY OTHER WARRANTIES, EXPRESS OR IMPLIED. TEKTRONIX AND ITS VENDORS DISCLAIM ANY IMPLIED WARRANTIES OF MERCHANTABILITY OR FITNESS FOR A PARTICULAR PURPOSE. TEKTRONIX' RESPONSIBILITY TO REPAIR OR REPLACE DEFECTIVE PRODUCTS IS THE SOLE AND EXCLUSIVE REMEDY PROVIDED TO THE CUSTOMER FOR BREACH OF THIS WARRANTY. TEKTRONIX AND ITS VENDORS WILL NOT BE LIABLE FOR ANY INDIRECT, SPECIAL, INCIDENTAL, OR CONSEQUENTIAL DAMAGES IRRESPECTIVE OF WHETHER TEKTRONIX OR THE VENDOR HAS ADVANCE NOTICE OF THE POSSIBILITY OF SUCH DAMAGES.

[W2 – 15AUG04]



---

# Table of Contents

General Safety Summary .....	v
Service Safety Summary .....	vii
Preface .....	ix
Manual Conventions .....	ix
Related Manuals .....	ix

## Introduction

Introduction .....	1-1
Service Strategy .....	1-1
Specifications .....	1-1
Performance Verification .....	1-1
Options and Accessories .....	1-1
Configurations .....	1-1
Hardware Installation .....	1-2
Product Upgrade .....	1-2
Operating Information .....	1-2

## Theory of Operation

Theory of Operation .....	2-1
Serial Digital Input .....	2-2
Composite Input .....	2-2
Reference Input .....	2-2
Digital Waveform Processing Engine .....	2-2
Rasterizing Engine .....	2-4
Recursion and Picture Processing Engine .....	2-4
Control Processor .....	2-4
Front Panel .....	2-5
LTC .....	2-5
Audio Option Board .....	2-5
Audio Processing .....	2-6
Audio Inputs .....	2-6
Audio Outputs .....	2-6
Option EYE/PHY .....	2-6
Fault LED and Fan Block Diagram .....	2-8
Power Supply and Distribution .....	2-10

## Adjustment Procedures

Adjustments .....	3-1
-------------------	-----

## Maintenance

General Maintenance .....	4-1
Preventing ESD .....	4-1
Inspection and Cleaning .....	4-2
Troubleshooting .....	4-5
Detailed Troubleshooting Procedures .....	4-11
Repackaging Instructions .....	4-27
Packaging .....	4-27
Shipping to the Service Center .....	4-27

## Replaceable Mechanical Parts

Replaceable Parts .....	5-1
Parts Ordering Information .....	5-1
Using the Replaceable Parts Lists .....	5-2



---

# List of Figures

Figure 2-1: WVR7020, WVR7120, and WVR6020 Waveform Rasterizers block diagram .....	2-3
Figure 2-2: High-level fault and fan block diagram .....	2-9
Figure 4-1: Main board indicator LED, connector, and test point locations .....	4-23
Figure 4-2: Options AD and DDE Audio board, component side .....	4-24
Figure 4-3: Options AD and DDE Audio board back side indicator LED and test point locations ...	4-25
Figure 4-4: Front panel board indicator LED locations (viewed from back side).....	4-26
Figure 5-1: Replaceable parts, circuit boards and chassis .....	5-5
Figure 5-2: WVR6020, WVR7020, and WVR7120 replaceable cables, connectors, and other mechanical parts .....	5-7
Figure 5-3: Main board replaceable components and connectors, WVR7020, WVR7120, and WVR6020 .....	5-9
Figure 5-4: Option EYE/PHY and Audio Options boards and connectors .....	5-11
Figure 5-5: Audio board component-side components, Options AD and DDE .....	5-13
Figure 5-6: Audio board back-side components, Options AD and DDE.....	5-15
Figure 5-7: WVR RFP.....	5-17
Figure 5-8: Analog audio breakout cable assembly .....	5-18

## List of Tables

Table i: Related documentation .....	ix
Table 2-1: Supported audio options .....	2-5
Table 4-1: External inspection check list .....	4-3
Table 4-2: Internal inspection check list .....	4-3
Table 4-3: Required test equipment .....	4-6
Table 4-4: Symptoms and causes .....	4-7
Table 4-5: Circuits that can assert faults .....	4-12
Table 4-6: Digital secondary supplies .....	4-15
Table 4-7: Analog supplies .....	4-15
Table 4-8: Audio secondary supplies .....	4-15

# General Safety Summary

Review the following safety precautions to avoid injury and prevent damage to this product or any products connected to it.

To avoid potential hazards, use this product only as specified.

*Only qualified personnel should perform service procedures.*

While using this product, you may need to access other parts of a larger system. Read the safety sections of the other component manuals for warnings and cautions related to operating the system.

## To Avoid Fire or Personal Injury

**Use Proper Power Cord.** Use only the power cord specified for this product and certified for the country of use.

**Connect and Disconnect Properly.** Do not connect or disconnect probes or test leads while they are connected to a voltage source.

**Ground the Product.** This product is grounded through the grounding conductor of the power cord. To avoid electric shock, the grounding conductor must be connected to earth ground. Before making connections to the input or output terminals of the product, ensure that the product is properly grounded.

**Observe All Terminal Ratings.** To avoid fire or shock hazard, observe all ratings and markings on the product. Consult the product manual for further ratings information before making connections to the product.

Do not apply a potential to any terminal, including the common terminal, that exceeds the maximum rating of that terminal.

**Power Disconnect.** The power cord disconnects the product from the power source. Do not block the power cord; it must remain accessible to the user at all times.

**Do Not Operate Without Covers.** Do not operate this product with covers or panels removed.

**Do Not Operate With Suspected Failures.** If you suspect that there is damage to this product, have it inspected by qualified service personnel.

**Avoid Exposed Circuitry.** Do not touch exposed connections and components when power is present.

**Replace Batteries Properly.** Replace batteries only with the specified type and rating.

**Recharge Batteries Properly.** Recharge batteries for the recommended charge cycle only.

**Use Proper Fuse.** Use only the fuse type and rating specified for this product.

**Wear Eye Protection.** Wear eye protection if exposure to high-intensity rays or laser radiation exists.

**Do Not Operate in Wet/Damp Conditions.**

**Do Not Operate in an Explosive Atmosphere.**

**Keep Product Surfaces Clean and Dry.**

**Provide Proper Ventilation.** Refer to the manual's installation instructions for details on installing the product so it has proper ventilation.

**Terms in this Manual** These terms may appear in this manual:



**WARNING.** *Warning statements identify conditions or practices that could result in injury or loss of life.*

---



**CAUTION.** *Caution statements identify conditions or practices that could result in damage to this product or other property.*

---

**Symbols and Terms on the Product**

These terms may appear on the product:

- DANGER indicates an injury hazard immediately accessible as you read the marking.
- WARNING indicates an injury hazard not immediately accessible as you read the marking.
- CAUTION indicates a hazard to property including the product.

The following symbol(s) may appear on the product:



## Service Safety Summary

Only qualified personnel should perform service procedures. Read this *Service Safety Summary* and the *General Safety Summary* before performing any service procedures.

**Do Not Service Alone.** Do not perform internal service or adjustments of this product unless another person capable of rendering first aid and resuscitation is present.

**Disconnect Power.** To avoid electric shock, switch off the instrument power, then disconnect the power cord from the mains power.

**Use Care When Servicing With Power On.** Dangerous voltages or currents may exist in this product. Disconnect power, remove battery (if applicable), and disconnect test leads before removing protective panels, soldering, or replacing components.

To avoid electric shock, do not touch exposed connections.



# Preface

This manual supports servicing to the module level of the WVR6020, WVR7020, and WVR7120 Waveform Rasterizers, which rasterize video signals for XGA display. The rasterizer finds use as a monitor for broadcasting, production, and post-production environments.

This manual explains how to troubleshoot and service the rasterizer to the module level. The manual is divided into the following sections:

- *Introduction* provides a general product description and tells where to find product installation information.
- *Theory of Operation* provides descriptions of the rasterizer modules.
- *Maintenance* tells you how to troubleshoot the product to the module level and how to handle the modules.
- *Replaceable Parts* illustrates the replaceable modules and mechanical parts and provides replacement part numbers.

## Manual Conventions



The following terms and conventions are used throughout this manual:

- The terms "rasterizer" and "instrument" are used interchangeably to refer to the WVR6020, WVR7020, and WVR7120 Waveform Rasterizers.
- Where information is model-specific to either the WVR6020, WVR7020, or WVR7120 model, it is indicated as such. (See page 1-1, *Configurations*.)

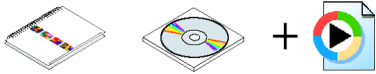

## Related Manuals

This manual assumes you have access to the following manuals when servicing this product. These manuals ship with the product and are also downloadable from the Tektronix Web site.

Table i: Related documentation

Item	Purpose	Location
WVR6020, WVR7020, WVR7120, WVR6020 Opt. MB, WVR7020 Opt. MB, and WVR7120 Opt. MB Waveform Rasterizers Quick Start User Manual	Installation and high-level operational overview	
WVR6020, WVR7020, and WVR7120 Online Help	In depth operation and UI help	

**Table i: Related documentation (cont.)**

<b>Item</b>	<b>Purpose</b>	<b>Location</b>
<i>WVR6020, WVR7020, WVR7120, WVR6020 Opt. MB, WVR7020 Opt. MB, and WVR7120 Opt. MB Waveform Rasterizer Specifications and Performance Verification</i>	Procedure for checking performance and list of specifications	
<i>WVR &amp; WFM Series Master Information Base</i>	Programmers command reference for controlling the waveform rasterizer	



---

# Introduction



---

# Introduction

The WVR6020, WVR7020, and WVR7120 Waveform Rasterizers rasterize serial digital video and composite video signals (depending on installed options) for an XGA display, providing a new standard of display quality and flexibility.

## Service Strategy

The Waveform Rasterizer will be repaired to the module level at selected Tektronix service centers. Repair includes functional verification of the product.

## Specifications

The specifications for this product are found on the *WVR6020, WVR7020, and WVR7120 Documents CD* that ships with the product and is published on the Tektronix Web site. (See page ix, *Related Manuals*.)

## Performance Verification

The Performance Verification procedure for this product is found in the *WVR6020, WVR7020, and WVR7120 Documents CD* that ships with the product and is published on the Tektronix Web site. (See page ix, *Related Manuals*.)

## Options and Accessories

The lists of options and accessories for this product are found in the *WVR6020, WVR7020, WVR7120, WVR6020 Opt. MB, WVR7020 Opt. MB, and WVR7120 Opt. MB Waveform Rasterizers Quick Start User Manual* that ships with the product. (See page ix, *Related Manuals*.)

## Configurations

- WVR6020** The base WVR6020 instrument monitors SD inputs, and can be ordered with options CPS to add monitoring of analog composite inputs, options AD or DDE for multiple-channel audio, and options EYE or PHY for physical-layer measurements.
  
- WVR7020** The base WVR7020 instrument monitors SD inputs, and can be ordered with option HD to add monitoring of HD inputs, option CPS to add monitoring of analog composite inputs, or option AD for multiple-channel audio.

**WVR7120** The base WVR7120 instrument monitors SD inputs, and can be ordered with option HD to add monitoring of HD inputs, CPS to add monitoring of analog composite inputs, options AD or DDE for multiple-channel audio, and options EYE or PHY for physical-layer measurements.

**WVRRFP** A Remote Front Panel, WVRRFP, is available as a companion product. When connected, both front panels are fully operational.

## Hardware Installation

This product is to be rack mounted. For installation instructions, refer to the *WVR6020*, *WVR7020*, *WVR7120*, *WVR6020 Opt. MB*, *WVR7020 Opt. MB*, and *WVR7120 Opt. MB Waveform Rasterizers Quick Start User Manual*.

## Product Upgrade

Hardware and software upgrades are available for all products, either as a field upgrade kit or as a free software download from the Tektronix.com Web site. The *WVR6020*, *WVR7020*, *WVR7120*, *WVR6020 Opt. MB*, *WVR7020 Opt. MB*, and *WVR7120 Opt. MB Waveform Rasterizers Quick Start User Manual* includes instructions for updating product firmware.

## Operating Information

For basic operating instructions, refer to the *WVR6020*, *WVR7020*, *WVR7120*, *WVR6020 Opt. MB*, *WVR7020 Opt. MB*, and *WVR7120 Opt. MB Waveform Rasterizers Quick Start User Manual* that shipped with this product, and for more detailed reference information, refer to the instrument Online help (Push the HELP button to display online help on the rasterizer screen.)

**Power-On Procedure** This product has no power switch; to power it up, plug it in to a line voltage source.

1. Wait for the system to complete its power-on self-tests.

**Power-Down Procedure** Unplug the instrument.

---

# Theory of Operation



---

# Theory of Operation

The base WVR6020 instrument monitors SD inputs, and can be ordered with options CPS to add monitoring of analog composite inputs, options AD or DDE for multiple-channel audio, and options EYE or PHY for physical-layer measurements.

The base WVR7020 instrument monitors SD inputs, and can be ordered with option HD to add monitoring of HD inputs, option CPS to add monitoring of analog composite inputs, or option AD for multiple-channel audio.

The base WVR7120 instrument monitors SD inputs, and can be ordered with option HD to add monitoring of HD inputs, CPS to add monitoring of analog composite inputs, options AD or DDE for multiple-channel audio, and options EYE or PHY for physical-layer measurements.

All models use an external XGA monitor for the display. This section covers the full capability, so some portions may not apply to a model with fewer features.

This theory of operation is mainly based on the High-level block diagram. (See Figure 2-1.) When necessary, other block diagrams may also be referenced. The upper portion of the block diagram covers functions on the main board. The lower section covers those of the audio board. The primary functions on the main board are:

1. Serial Digital Input
2. Composite input
3. Reference Input
4. Digital Waveform Processing Engine
5. Rasterizing Engine
6. Recursion and Picture processing Engine
7. Control Processor and it's associated peripherals
8. Front Panel
9. LTC decoder

The primary functions on the audio board are:

1. Processing
2. Inputs
3. Outputs

There are also miscellaneous circuits such as the fans and their thermal control system, and the "Fault" bus. These are covered in the High-level fault and fan block diagram.(See Figure 2-2.)

Power Distribution is not shown in the block diagram but is covered at the end of this section.

## Serial Digital Input

The serial digital signal inputs are passive loop-throughs, so they must be terminated to operate properly. Each input is applied to a cable equalizer and then to a serial-to-parallel conversion circuit. The output of these sections are parallel data and a word clock.

## Composite Input

The Composite inputs are also passive loop-throughs. If unterminated, the signal appears twice as large as it should. The two sets of inputs go through a 2-to-1 multiplexer; then the selected signal is clamped if selected by the user. After the clamp, the signal is filtered and then applied to an A-to-D converter to generate a 12-bit parallel signal. There is also a sync separator to generate timing information and a picture decoder. The output of the picture decoder is very similar to the parallel data from the serial digital input. The separated sync passes on to the waveform processing (WFM) FPGAs, where it is processed in the digital domain.

## Reference Input

The Reference input is a passive loopthrough similar to that of the Composite inputs. The buffered signal is clamped and then digitized to generate a 10-bit stream. A simple sync separator generates timing information, which is sent to the waveform processing FPGAs. As on the composite inputs, the separated sync from the reference passes on to the WFM FPGAs, where it is processed in the digital domain.

## Digital Waveform Processing Engine

The parallel data streams from all three video inputs are applied to the waveform processing FPGA. This block up-samples, interpolates, demodulates and otherwise processes the data to generate the signals needed to create the displays.



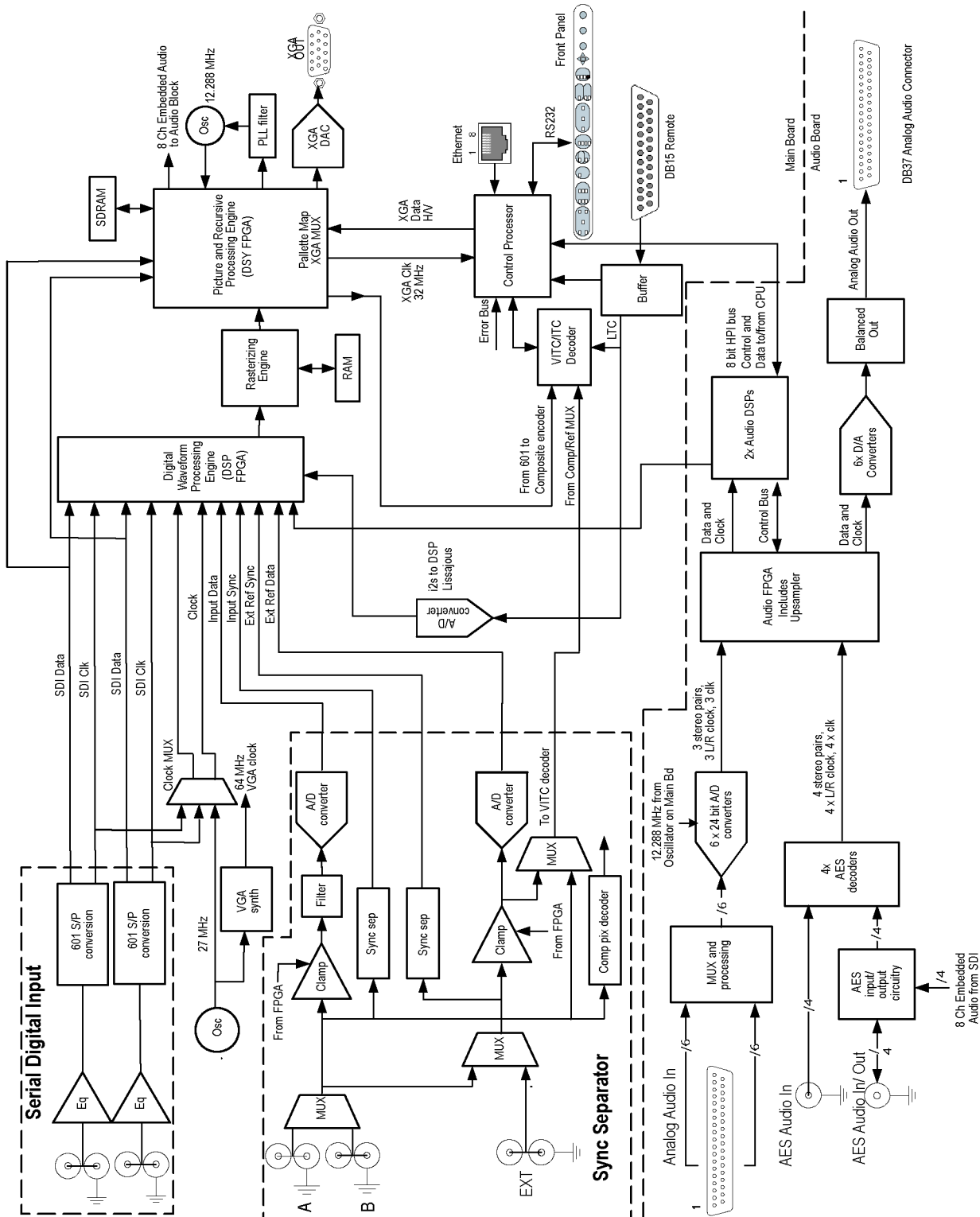

Figure 2-1: WVR7020, WVR7120, and WVR6020 Waveform Rasterizers block diagram

## Rasterizing Engine

The Rasterizer engine resides in the waveform processing FPGAs. This block builds up the variable intensity images in the fast static RAM. For each pixel of the display, the Rasterizer Engine increments the intensity of that pixel every time the waveform hits its coordinates. As a result, the waveform areas hit more frequently display more brightly. For any given frame, the intensity map is built up in one memory chip and read out of the other. The functions swap on the next frame.

## Recursion and Picture Processing Engine

The output of the rasterizer feeds the picture and recursive processing engine in the display (DSY) FPGA. This engine adds the previous frame to the present frame to reduce flicker and improve brightness. It also converts the picture and waveform signals from the input rate of 50 or 59.94 Hz to 60 Hz frame rate to work with the XGA monitor. The picture and waveform data combine with the graphics and audio bar information from the control processor, and then output to the XGA DAC to drive the external monitor. Note that the parallel data from the serial digital input and the parallel stream from the composite decoder connect directly to this FPGA to provide the picture functionality, bypassing the waveform processing engine.

## Control Processor

The control processor is in charge of all the operational modes in the instrument. It draws the audio bars, communicates with the front panel through RS232 signaling, and controls most other internal devices though either the parallel or the I2C bus. A few parts communicate through other bus types like JTAG or SPI. Audio data is input to the control processor via the 8 bit HPI bus.

The control processor interfaces to the Ethernet through a dual rate switch. This allows the network connection to run at 10 or 100 MB/s.

## Front Panel

The front panel contains a small processor that communicates to the control processor through RS232 signaling. Power, ground, fault and a programming signals allow the front panel processor flash code to be updated.

## LTC

LTC signals are routed to the decoder chip. The control processor reads the time values from the decoder chip. If selected by the user, the decoded time values can be displayed on the XGA monitor and used to time stamp alarm log entries.

LTC inputs come from the remote connector. The LTC signal is also applied to an A/D converter and then input to the waveform processing FPGA to create the LTC waveform display.

---

**NOTE.** *The FPGA's decode VITC signals digitally.*

---

## Audio Option Board

The audio option (if installed) resides on the upper "mezzanine" board.

There are two audio options:

- Option AD adds support for Analog audio and Digital audio monitoring
- Option DDE adds support for Dolby E decode, Dolby Digital (AC-3) decode, and Analog/Digital audio monitoring

**Table 2-1: Supported audio options**

To add this option to a previously purchased instrument	Order this kit		
	WVR6020	WVR7020	WVR7120
AD	WVR6UP-AD	WVR70UP-AD	WVR7UP-AD
DDE	WVR6UP-DDE	not supported	WVR7UP-DDE

## Audio Processing

The audio options use an FPGA to route the audio input into two DSP chips whose main function is to calculate the peak values for the selected meter ballistics (response characteristics).

The audio data has two paths to the display. On one path, peak values are sent to the control processor which then plots the bar displays. On the second path, raw data samples are sent to the waveform processing engine which interpolates and plots them to generate the lissajous display.

## Audio Inputs

There are three basic audio input paths: AES, analog, and embedded. AES inputs are accepted at rates up to 192 kHz. All input data rates are resampled at 192 kHz before processing by the DSPs.

Analog inputs are digitized at 48 kHz and then go through the same path as the AES inputs.

The embedded audio path starts at the DSY FPGA. First the audio samples are extracted from the serial digital video data using a 12.288 MHz oscillator and sent to the audio board. At the audio board, the streams are multiplexed into the AES decoders and then follow the same path as the AES data. The user can choose to have the de-embedded audio output on the AES B port.

## Audio Outputs

There are two audio outputs, analog and AES. Both outputs always follow the source that is currently selected for the audio bar display. The analog outputs can come from any input. The selected signal output from the FPGA, is converted from digital to analog and then sent as a balanced output to the rear panel Dsub connector.

The AES outputs are available with any input. They can serve as an active loop-through if the input is AES, a de-embedder if the input is embedded, or an A/D converter if the input is analog.

## Option EYE/PHY

Options EYE and PHY provide the following features:

- Eye pattern display
- Jitter waveform display<sup>1</sup>
- Jitter readout

- Jitter Meter
- Cable Loss readout
- Approx Cable readout
- Source Level readout
- Eye Amplitude readout <sup>1</sup>
- Eye Risetime readout <sup>1</sup>
- Eye Falltime readout <sup>1</sup>
- Eye Rise-Fall (difference) readout <sup>1</sup>

<sup>1</sup> Requires Option PHY.

Options EYE and PHY support both HD and SD SDI signals, limited by the capability of the instrument they are installed in:

- WVR6020: Not applicable; EYE and PHY options are not supported.
- WVR7020: Not applicable; EYE and PHY options are not supported.
- WVR7120: HD only.
- WVR7120 Option SD: Both HD and SD.

The hardware to support these features is contained on the Eye board, which is installed on standoffs over the left front quadrant of the Main board.

The Eye board receives an input signal through two coaxial cables. These coaxial cables bring the input signal from the Loophrough board. Output data and control I/O pass through a 60-pin connector (J6) to the Main board. Most of the power required is provided by a two-conductor cable directly from the main power supply (+5 V) to J3 on the Eye board. A small amount of additional power is supplied through J6, from the Main board.

**Operation.** The selected SDI input signal is sampled by a wideband track-and-hold circuit, and then digitized. The same signal is also applied to a cable equalizer and clock recovery circuit. The recovered clock is divided by 10 for SD (by 20 for HD), filtered to form a sine wave, and then digitized. Both the SDI input and the recovered clock sine wave are sampled by the same asynchronous clock, and then both are passed to the main board for processing by FPGAs. These arrays produce the Eye Display, Jitter Display, Jitter Readout, and Jitter Thermometer. The Eye Display data is further processed to derive the Eye Amplitude, Eye Rise Time, and Eye Fall Time measurements, which are shown in the SDI Status Display.

The selected SDI input signal also drives the Cable Meter circuit, which measures signal energy at two frequencies. These measurements are read by the CPU on the Main board, which calculates Cable Loss, Approximate Cable Length, and Source Level for display in the SDI Status screen.

## Fault LED and Fan Block Diagram

The Fan control and the bus that drives the front-panel "Fault" LED, the *High-level fault and fan block diagram*. (See Figure 2-2 on page 2-9.)

The fan circuit senses the temperature to set the fan speed. Each fan has a tachometer output to indicate fan speed so the circuit can run the fans at low speed without stalling. The slower of the two fans controls a power supply that provides the voltage for both fans. If a fan is not turning, the circuit senses the stall and asserts the fault line and a line to the control processor so the event can be entered in the diagnostic log.

The front panel "Fault" LED is driven by a line accessible by most of the instrument. The concept is to provide fault information independent of the control processor, since it may not always be working. If any circuit detects a fault, it pulls the fault line low. This line is what is called a "wire-OR." Circuits are also expected to assert a local LED when asserting the fault line. Because of this local LED, a technician should be able to look inside the box and see a red LED near the site of the fault. Faults are usually also sent independently to the control processor.

For details about the circuits that can assert the fault light and their associated local LEDs. (See page 4-5, *Troubleshooting*.)

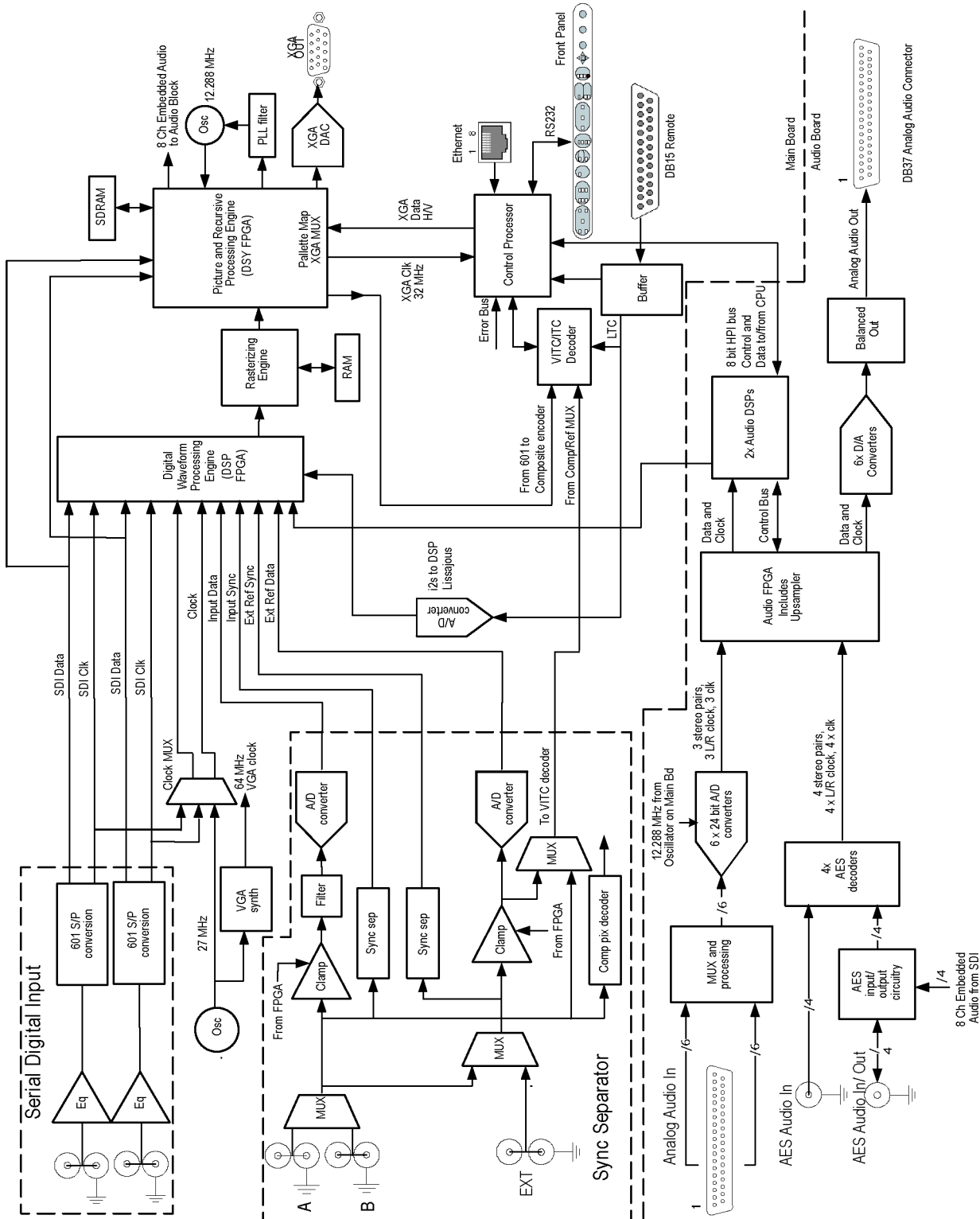

Figure 2-2: High-level fault and fan block diagram

## Power Supply and Distribution

The power supply has a universal AC input that enables it to accommodate 100 VAC to 264 VAC without any user range switching. The output is 5 V DC. Circuits convert this output to any other supply voltage that they require at the point of usage.

Fuses on the Primary supply 5 V output protect the main board. See the diagrams in the troubleshooting section for locations of these fuses.

The secondary supplies and their tolerances are specified in the troubleshooting section. The location of the supply test points is shown in *Maintenance* section.



---

# Adjustment Procedures



---

# Adjustments

The waveform rasterizer does not normally require any adjustments. The adjustments which can be made should only be made while performing a Performance Verification. Refer to the following procedures in the *WVR6020, WVR7020, WVR7120, Specifications and Performance Verification Technical Reference* manual (on the Product Documentation CD that shipped with this instrument) for the adjustments:

- *Composite Analog Vertical Measurement Accuracy* (Option CPS only),
- *Composite Analog Frequency Response* (Option CPS only),
- *Composite Analog Input DC Offset Restore Off* (Option CPS only)
- *Analog Audio Level Meter Accuracy Over Frequency* (Options AD and DDE only)
- *HD Cable Meter* (WVR7120 Option EYE or PHY only)
- *HD Jitter Noise Floor* (WVR7120 Option EYE or PHY only)
- *Eye Gain* (WVR7120 Option EYE or PHY only)
- *SD Cable Meter* (WVR7120 Options EYE and PHY)



---

# Maintenance



---

# General Maintenance

This section contains the information needed to perform periodic and corrective maintenance on the waveform rasterizer. The following subsections are included:

- *Preventing ESD* — General information on preventing damage by electrostatic discharge.
- *Inspection and Cleaning* — Information and procedures for inspecting and cleaning the waveform rasterizer.
- *Troubleshooting* — Information for isolating and troubleshooting failed modules. Included are instructions for operating the waveform rasterizer diagnostic routines and troubleshooting trees. Most of the trees make use of the internal diagnostic routines to speed fault isolation to a module.
- *Repackaging Instructions* — Information on returning a waveform rasterizer for service.

## Preventing ESD

Before servicing this product, read the *Safety Summary* and *Introduction* at the front of the manual and the ESD information below.



**CAUTION.** *Static discharge can damage any semiconductor component in the waveform rasterizer.*

---

When performing any service that requires internal access to the waveform rasterizer, adhere to the following precautions to avoid damaging internal modules and their components due to electrostatic discharge (ESD).

1. Minimize handling of static-sensitive circuit boards and components.
2. Transport and store static-sensitive modules in their static protected containers or on a metal rail. Label any package that contains static-sensitive boards.
3. Discharge the static voltage from your body by wearing a grounded antistatic wrist strap while handling these modules. Do service of static-sensitive modules only at a static-free work station.
4. Nothing capable of generating or holding a static charge should be allowed on the work station surface.
5. Handle circuit boards by the edges when possible.
6. Do not slide the circuit boards over any surface.
7. Avoid handling circuit boards in areas that have a floor or work-surface covering capable of generating a static charge.

## Inspection and Cleaning

*Inspection and Cleaning* describes how to inspect for dirt and damage. It also describes how to clean the exterior and interior of the waveform rasterizer. Inspection and cleaning are done as preventive maintenance. Preventive maintenance, when done regularly, may prevent waveform rasterizer malfunction and enhance its reliability.

Preventive maintenance consists of visually inspecting and cleaning the waveform rasterizer and using general care when operating it.

How often maintenance should be performed depends on the severity of the environment in which the waveform rasterizer is used. A proper time to perform preventive maintenance is just before any waveform rasterizer adjustment.

**General Care** The cabinet helps keep dust out of the waveform rasterizer and should normally be in place when operating the waveform rasterizer.

**Module Handling** When handling modules comprising circuit boards, especially larger circuit boards, support the board on two sides to avoid flexing of the board material. Flexing can cause breaks in the solder joints of SMDs.



**WARNING.** *Before performing any procedure that follows, power down the instrument and disconnect it from line voltage.*

---

**Interior Cleaning** Use a dry, low-velocity stream of air to clean the interior of the chassis. Use a soft-bristle, non-static-producing brush for cleaning around components. If you must use a liquid for minor interior cleaning, use a 75% isopropyl alcohol solution and rinse with deionized water.

**Exterior Cleaning** Clean the exterior surfaces of the chassis with a dry lint-free cloth or a soft-bristle brush. If any dirt remains, use a cloth or swab dipped in a 75% isopropyl alcohol solution. Use a swab to clean narrow spaces around controls and connectors. Do not use abrasive compounds on any part of the chassis that may damage the chassis.



**CAUTION.** *Avoid the use of chemical cleaning agents that might damage the plastics used in the waveform rasterizer. Use only deionized water when cleaning the front-panel buttons. Use a 75% isopropyl alcohol solution as a cleaner and rinse with deionized water. Before using any other type of cleaner, consult your Tektronix Service Center or representative.*

---



**Inspection — Exterior.** Inspect the outside of the waveform rasterizer for damage, wear, and missing parts, using the following table as a guide. Immediately repair defects that could cause personal injury or lead to further damage to the waveform rasterizer.

**Table 4-1: External inspection check list**

Item	Inspect for	Repair action
Cabinet, front panel, and cover	Cracks, scratches, deformations, damaged hardware	Repair or replace defective module
Front-panel knobs	Missing, damaged, or loose knobs	Repair or replace missing or defective knobs
Connectors	Broken shells, cracked insulation, and deformed contacts. Dirt in connectors	Repair or replace defective modules. Clear or wash out dirt
Rackmount slides	Correct operation	Repair or replace defective module
Accessories	Missing items or parts of items, bent pins, broken or frayed cables, and damaged connectors	Repair or replace damaged or missing items, frayed cables, and defective modules

**Inspection — Interior.** To access the inside of the waveform rasterizer for inspection and cleaning, you will need to remove the top cover.

Inspect the internal portions of the waveform rasterizer for damage and wear, using the following table as a guide. Defects found should be repaired immediately.

If any circuit board is repaired or replaced, check the following table to see if it is necessary to adjust the waveform rasterizer.



**CAUTION.** To prevent damage from electrical arcing, ensure that circuit boards and components are dry before applying power to the waveform rasterizer.

**Table 4-2: Internal inspection check list**

Item	Inspect for	Repair action
Circuit boards	Loose, broken, or corroded solder connections. Burned circuit boards. Burned, broken, or cracked circuit-run plating.	Remove and replace damaged circuit board.
Resistors	Burned, cracked, broken, blistered condition.	Remove and replace damaged circuit board.
Solder connections	Cold solder or rosin joints.	Resolder joint and clean with isopropyl alcohol.

**Table 4-2: Internal inspection check list (cont.)**

<b>Item</b>	<b>Inspect for</b>	<b>Repair action</b>
Capacitors	Damaged or leaking cases. Corroded solder on leads or terminals.	Remove and replace damaged circuit board.
Wiring and cables	Loose plugs or connectors. Burned, broken, or frayed wiring.	Firmly seat connectors. Repair or replace modules with defective wires or cables.
Chassis	Dents, deformations, and damaged hardware.	Straighten, repair, or replace defective hardware.

**Cleaning Procedure — Interior.** To clean the waveform rasterizer interior, perform the following steps:

1. Blow off dust with dry, low-pressure, deionized air (approximately 9 psi).
2. Remove any remaining dust with a lint-free cloth dampened in isopropyl alcohol (75% solution) and rinse with warm deionized water. (A cotton-tipped applicator is useful for cleaning in narrow spaces and on circuit boards.)

---

**NOTE.** *If, after doing the above steps, a module is clean upon inspection, skip the remaining steps.*

---

3. If steps 1 and 2 do not remove all the dust or dirt, the waveform rasterizer may be spray washed using a solution of 75% isopropyl alcohol by doing steps 4 through 6.
4. Gain access to the parts to be cleaned by removing easily accessible shields and panels.
5. Spray wash dirty parts with the isopropyl alcohol and wait 60 seconds for the majority of the alcohol to evaporate.
6. Dry all parts with low-pressure, deionized air.

**Lubrication.** There is no periodic lubrication required for the waveform rasterizer.

## Troubleshooting

The procedures in this section will help you trace the root cause of a problem back to one of the replaceable parts. In general, this is a board-level replacement but there are a few components on some boards that are replaceable.



---

**WARNING.** *Before performing this or any other procedure in this manual, read the General Safety Summary and Service Safety Summary found at the beginning of this manual.*

---

To prevent possible injury to service personnel or damage to electrical components, please read Preventing ESD.(See page 4-1, *Preventing ESD.*)

### Getting Started

This procedure consists of two main sections; the first section contains the *Symptoms and Causes*

To properly test a waveform rasterizer you must have a known good XGA monitor and appropriate signal sources. Depending on what portion of the instrument you are testing, this might include Composite Video, Serial Digital Video, Analog Audio, or Digital Audio. In some cases, you may also need receivers or an oscilloscope to check outputs.

**Table 4-3: Required test equipment**

Test equipment	Requirements	Example
XGA Monitor	Computer monitor capable of 1024 x 768 x 60 Hz scan rate	
SDI serial digital video test generator with embedded audio and composite signal source	NTSC Black	Tektronix TG2000 with BG1 and additional modules indicated below.
	1080i 59.94 HD signals required for WVR7020 and WVR7120:	HDVG1 module for TG2000 (Embedded audio needed for audio options AD or DDE)
	<ul style="list-style-type: none"> <li>■ 100% color bars</li> <li>■ 10-bit shallow ramp</li> <li>■ SDI Matrix Split Field Pathological Signal</li> <li>■ 100% sweep</li> </ul>	
	HD signal with adjustable SDI amplitude required for WVR7120	HDST1 module for TG2000
	1080i 59.94 analog tri-level sync required for WVR7120	AWVG1 module for TG2000
	525/270 SD signals required for WVR7020 and WVR7120 Option SD, and for WVR6020:	DVG1 with option S1 module for TG2000 (Embedded audio needed for audio options AD or DDE)
	<ul style="list-style-type: none"> <li>■ 100% color bars</li> <li>■ 10-bit shallow ramp</li> <li>■ SDI Matrix Pathological Signal</li> <li>■ 100% sweep</li> <li>■ Adjustable SDI amplitude</li> </ul>	
Composite signals required for Option CPS: NTSC SMPTE bars	AVG1 module for TG2000	
Precision calibration signals for Option CPS	Tektronix part number 067-0465-00 module for TG2000	
AES Audio Signal Generator	48 kHz, 24 bit word length signals	Rohde & Schwarz UPL06, Tektronix AM700 and AM70.
Analog Audio Signal Generator		Rohde & Schwarz UPL06, Tektronix AM700 and AM70.
Voltmeter		Fluke 87 or equivalent
Oscilloscope	Video trigger capability	Tektronix TDS3000B Series

**Table 4-4: Symptoms and causes**

<b>Symptom</b>	<b>Possible sources or recommended detailed troubleshooting procedure to follow</b>
No LEDs lit and XGA output not working	Perform general checks Perform primary power supply checks Perform secondary power supply checks Replace main circuit board
Fault Light on after 15 sec boot up	Check error status page for more information Check diagnostic log for more information Perform fault LED problem isolation
Inconsistent or partial hardware failures	Perform primary power supply checks Perform secondary power supply checks Replace main circuit board
Fails any of these Power On Self Tests (POST): Timecode Decoder Cmpst Decoder Composite DAC DSP FPGA Display FPGA	Review messages in diagnostic log Perform primary power supply checks Perform secondary power supply checks Replace the main board
Diagnostic log shows Fail on any of these Advanced Diagnostics: ADV_DIAG_LSS	Review messages in diagnostic log. If the waveform rasterizer also fails other tests as well, then suspect main board and perform the primary and secondary power supply tests. If only this test fails, then perform <i>Isolating Advanced Diagnostic Lissajous Errors</i> procedure to isolate the problem to main or audio board.

**Table 4-4: Symptoms and causes (cont.)**

<b>Symptom</b>	<b>Possible sources or recommended detailed troubleshooting procedure to follow</b>
Failures while running the advanced diagnostics:	<ul style="list-style-type: none"> <li>■ Perform secondary power supply checks</li> <li>■ Replace the main board</li> </ul>
■ PLD Data Bus	
■ PLD Address Bus	
■ Power Supply	
■ Raster Data Bus Output	
■ Raster Data Bus Input	
■ Raster Data Bus Input	
■ Display Data Bus	
■ Display Address Bus	
■ DSP1 Data Bus	
■ DSP1 Address Bus	
■ DSP2 Data Bus	
■ DSP2 Address Bus	
■ DSP1 QDR1	
■ DSP1 QDR2	
■ DSP2 QDR1	
■ DSP2 QDR2	
■ Display SDRAM Data Bus	
■ Display SDRAM Address Bus	
■ DSP1 SDRAM Data Bus	
■ DSP1 SDRAM Address Bus	
■ DSP2 SDRAM Data Bus	
■ DSP2 SDRAM Address Bus	

**Table 4-4: Symptoms and causes (cont.)**

<b>Symptom</b>	<b>Possible sources or recommended detailed troubleshooting procedure to follow</b>
Failures while running the advanced diagnostics (Cont.):	<ul style="list-style-type: none"> <li>■ Perform secondary power supply checks</li> <li>■ Replace the main board</li> </ul>
<ul style="list-style-type: none"> <li>■ Display → DSP1 Bus Output</li> <li>■ Display → DSP1 Bus Input</li> <li>■ DSP1 → Display Bus Output</li> <li>■ DSP1 → Display Bus Input</li> <li>■ Display → DSP2 Bus Output</li> <li>■ Display → DSP2 Bus Input</li> <li>■ DSP2 → Display Bus Output</li> <li>■ DSP2 → Display Bus Input</li> <li>■ DSP1 → DSP2 Bus Output</li> <li>■ DSP1 → DSP2 Bus Input</li> <li>■ DSP2 → DSP1 Bus Output</li> <li>■ DSP2 → DSP1 Bus Input</li> </ul>	
Failures while running the advanced diagnostics (Cont.):	Replace the eye board
<ul style="list-style-type: none"> <li>■ Eye Power A2D</li> <li>■ Eye Cable A2D</li> <li>■ Eye Option</li> </ul>	
Failures while running the Audio PLL Frequency Check:	Replace the main board
<ul style="list-style-type: none"> <li>■ Lissajous Bus</li> <li>■ DSP1 Data Bus</li> <li>■ Display Composite Controls</li> <li>■ DSP1 Composite Tests</li> <li>■ DSP2 Composite Tests</li> </ul>	
Note: Only tests pertinent to installed options are reported.	
Log Message:	If the audio function works OK, but this message still appears occasionally, then upgrade the software to the current version, clear the log, and bench test to see if the problem persists. If it does, then search for an intermittent problem in the audio board, cables, or main board.
<ul style="list-style-type: none"> <li>■ Fail AUDIO_DSP_HEARTBEAT</li> </ul>	

**Table 4-4: Symptoms and causes (cont.)**

<b>Symptom</b>	<b>Possible sources or recommended detailed troubleshooting procedure to follow</b>
Functional Test Failures PVD Test Failures	<p>In case of failure on either Functional or the Performance tests, the board at fault is generally obvious. Before replacing a board:</p> <ol style="list-style-type: none"> <li>1. Perform the primary and secondary power supply checks.</li> <li>2. Run the advanced diagnostics and check the diagnostic log for help in isolating the fault.</li> </ol> <p>If this does not isolate the problem, then replace the main board if the test is in one of the following areas:</p> <ul style="list-style-type: none"> <li>■ SDI</li> <li>■ Composite</li> <li>■ Ref</li> <li>■ LTC</li> <li>■ XGA output</li> <li>■ Color Palette</li> <li>■ Remote I/O</li> <li>■ Ethernet</li> </ul> <p>If the problem is in the audio board, perform these tests:</p> <ol style="list-style-type: none"> <li>3. Isolating Advanced Diagnostic Lissajous errors.</li> <li>4. Audio POST Failure.</li> </ol>
Unknown Problems Often an instrument will come into service with vague or intermittent symptoms. In cases like these, the following set of tests may help find the problem or the marginal condition.	<ol style="list-style-type: none"> <li>1. Check the diagnostic log. This log records a variety of problems and will enable you to see messages for an error that may not be currently happening.</li> <li>2. Check the power supplies by performing the Primary and Secondary Supply checks. A marginal supply can lead to intermittent operation if it is near the acceptable threshold. This includes the main supply and the secondary supplies on each board</li> <li>3. Check the error log. This may give clues about how the unit was operating when the user saw problems.</li> <li>4. Run the functional test. This will exercise a majority of the functions in the unit and includes the advanced diagnostics. Some parts of the test may not be necessary for all problem areas.</li> <li>5. If the unit has an audio board, remove it and re-check any problem areas in the video performance. The audio board can place too much of a load on the supplies if they are marginal. If the performance changes with the audio board removed, then you should perform the primary and secondary power supply checks and look for an excess load on one of the supplies.</li> </ol>



## Detailed Troubleshooting Procedures

The following tests should be run as indicated in the *Symptom and Causes* table above. The procedures check for specific problems or will help you isolate a problem to a board. You can run them at any time for informational purposes but if you do not run the procedures in the correct context, then the final recommendation identifying a root cause might be suspect.

List of detailed troubleshooting procedures:

- General Checks
- Fault LED Problem Isolation
- Primary Power Supply Checks
- Secondary Power Supplies Checks
- Front Panel Troubleshooting
- Isolating Audio Problems
- Isolating Advanced Diagnostic Lissajous Errors.

### General Checks

Check that the power cord is installed.

1. Check that the XGA monitor cable is connected on both ends and that the screws are holding it securely.
2. Check that all internal cables are correctly connected and seated.
3. Check for any discolored or burned components.

### Fault LED Problem Isolation

The waveform rasterizer has a red FAULT LED on the front panel. This indicator lights up when specific types of problems occur in the instrument. The FAULT LED is different from the error icon on the XGA display, which indicates a problem with the signals. It is normal for the FAULT LED to be lit for 10 to 15 seconds during boot up.

The fault system is simple and does not require the processor be running to indicate faults. However, the fault system does not cover everything and does not give full details about the nature of the fault. Note that some problems that are covered by the FAULT LED are also reported to the diagnostic log.

If the instrument runs sufficiently to access the CONFIG menu, then check the diagnostic log for messages about the cause of the fault. Skip directly to that portion of this section if such information is available.

All subsystems that assert the FAULT LED also assert a local, red LED to indicate the area that generated the fault. Thus, whenever the instrument fault line is asserted, you need only remove the top cover and look for the red LEDs inside to find the location of the fault. The following table lists the circuits that can assert faults and identifies the LEDs associated with the circuit. (See Figure 4-2 on page 4-24.) There are also duplicates of the instrument FAULT LED and the audio fault LED on the main board (DS940 and DS840.) (See Figure 4-1 on page 4-23.)

**Table 4-5: Circuits that can assert faults**

Circuit area	Local LED
Fans	DS170, DS270
Audio	DS590 on main
Front Panel	DS252 (between preset 1, 2) on Front Panel board
CPU	DS680

**Fan Failures.** One possible source of an asserted FAULT LED is a fan failure.

If the right-side fan fails, then LED DS170 will be lit.

If the left-side fan fails, the LED DS270 will be lit.

The fan failure is sensed through tachometer feedback, thus a fault will be asserted if the fan is not connected, stalled, or if the tachometer feedback line is not working correctly.

If one fan fails, the control circuit will increase the voltage and the other fan will be driven at full speed.

If neither fan is spinning, then check fuse F70 and the dedicated switching supply that drives them.

If both fans are spinning, but one is showing a fault, swap the fans. If the problem moves with the fan, then replace the defective fan. If the fault does not track the swap, then there is a problem on the main board.

The normal voltage to drive the fans (pin 1) varies from about 6 V to 13.5 V in response to temperature and fan speed.

**DSP.** The following conditions can assert the FAULT LED from the DSP circuitry:

- Over temperature 2.5 V supply
- Over temperature 3.3 V supply

If any of these are in fault condition, the front-panel FAULT light will be lit and the local, red LED DS550 will be lit. Over temperature faults are reported in the diagnostic log - so you can look there to see if the DSP is asserting the line and which supply is the root cause.

If the system is not running, then check the voltage on the 2.5 V and 3.3 V supplies. If these are good, then check the temperature of the regulators U50 and U60. If they are hot to touch, then they are overloaded or defective; replace the main board.

Additionally, there are LEDs, DS260, DS261, and DS262, on the "Power Good" lines from each of the DSP secondary supplies. If the supply has fallen out of regulation, then the Power Good LED will not be lit.

**Audio.** The board has one watch-dog LED for each processor and one LED for the FPGA. The LED for DSP0, DS0310, blinks at 1 Hz and the LED for DSP1, DS420, blinks at 0.5 Hz. The LED for the FPGA, DS0820, is dim if the FPGA is not programmed and bright if it is programmed. If any of the LEDs are continuously off, replace the audio board.

The POST does the following:

- Reads all of the AES decoder internal registers and verifies that what is read is correct
- Tests the D/A control interface
- Performs an active-bit test on the A/D output clocks
- Checks the serial EEPROM to see which of the analog inputs have been calibrated
- Tests the Audio DSP/FPGA interface
- The AES encoder internal registers are read and verified
- The DSP interface between the Dolby E and Dolby Digital decoders is tested
- The main CPU asserts the fault line if the DSP heartbeat fails. This condition will be shown in the diagnostic log.

**Front Panel.** The front panel local fault LED is DS252 (behind the PRESETS buttons near the top of board ). The LED that shows through the panel is DS890.

If the Front panel asserts the Fault line, then replace the front panel board.

The front-panel processor asserts the fault indicator for about 1 second during reset. If it does not finish initializing and running internal diagnostics, then the fault LED remains lit. If the front-panel processor detects a fault in the diagnostics, then it leaves the fault asserted after it finishes.

The internal tests are:

- **RAM Test** - Entire RAM is tested. If this test fails, the ROM Test is skipped.
- **ROM Test** - The front-panel processor calculates the checksum of the program stored in flash and compares it with the stored checksum.

**CPU.** The CPU fault LED is DS680. The CPU section also has DS591, which is a duplicate of the FAULT LED, and DS590, which is a duplicate of the audio fault light.

The CPU can detect that the fault line is asserted. If the user has configured the alarm section to monitor hardware faults, then alarms will be generated and / or logged as set by the user. Since the CPU has access to many of the individual error flags, some of these are displayed on the diagnostic log.

The CPU can also assert the fault line for some failures during initialization and power on self test (POST).

If the CPU is asserting the fault line, then replace the main board.

### Primary Power Supply Tests

This section describes methods for verifying the proper operation of the waveform rasterizer primary power supply.



---

**WARNING.** *Some parts of this test require removing the insulating safety shield. To avoid personal injury, be careful not to contact the circuitry while the shield is removed. Be sure to replace the shield as soon as possible to prevent injury.*

---

The main power supply accepts 100 to 264 VAC and outputs 5 VDC. The output voltage at the supply must be between 4.9 and 5.3 V for correct operation. On the main board, the common 5 V supply must be between 4.80 and 5.25 V.

If the voltage at the output of the supply is not correct, check the input voltage. If the input voltage is in the correct range, then replace the power supply.

If the supply output voltage is zero, then check the input circuit. The voltage should be the same at the line cord, at the input to the power supply, and on both ends of the fuse on the input to the supply. If the input voltage is correct while the output is not, replace the supply. If the input voltage is not correct replace the element in the chain that is not passing the AC input.

If the power supply output is correct, also check the fuses F40, F50, F51 and F160 in the 5 V system near the main board power connector J581. All should have 5 V on both sides. If not, replace the fuse. (See Figure 4-1.)

### Secondary Power Supply Tests

There are multiple secondary supplies that are derived from the main 5 V supply. Be sure all fuses are good (as noted in *Primary Power Supply Tests*) before checking the secondary supplies.

First, check the digital secondary supplies as shown in the following table. Each supply has an LED and a test point. If any supplies are out of range, replace the main board. (See Figure 4-1.)

**Table 4-6: Digital secondary supplies**

Nominal (+V)	Allowed range (+V)	Measure at
1.5	1.4 to 1.6	TP430
1.8	1.7 to 1.9	TP20
2.5	2.4 to 2.6	TP432
2.6	2.6 to 2.8	TP19
3.3	3.3 to 3.55	TP530
5.0	4.75 to 5.25	TP531

After you have checked the Digital Secondary Supplies, check the Analog supplies as shown in the following table. These have LEDs and test points. If any voltages are out of tolerance, replace the main board. (See Figure 4-1.)

**Table 4-7: Analog supplies**

Nominal (V)	Allowed range (V)	Measure at
-5	-5.2 to -4.8	TP171
+5 "good"	+4.75 to 5.25	TP383

Check the Audio supplies on the Audio board as shown in the following table, (if an Audio board is installed). The test points are available, with the board installed, at the location specified. Check fuse F870 if there are no audio supply voltages. (See Figure 4-3 on page 4-25.)

**Table 4-8: Audio secondary supplies**

Supply name	Range
+1.26 V	1.20 to 1.32
+1.5 V	1.425 to 1.575
+1.8 V	1.71 to 1.89
+3.3 V	3.1 to 3.6
+5 VA	4.8 to 5.2
+5 V	4.8 to 5.2
-5 V	-4.5 to -5.5
+15 V	14 to 15.5
-15 V	-14 to -15.5

**Front Panel  
Troubleshooting**

If the instrument has a reasonable display on the screen, but the front panel does not work, follow this procedure:

1. Do the LEDs turn on for 2 to 3 seconds at power up? If not, check the 5 V fuse, F130, on the main board and check the cable from the main board to the front panel. If there is power to the front panel and the LEDs do not turn on at power up, then replace the front panel board.
2. After power up, do most of the LEDs turn on and stay on? If not, proceed to next step. Otherwise probe J390, pin 6 and pin 7 on the main board. Pin 6 should be TTL high (about 3.3 V) and pin 7 should be low (RS232 level, about -7 V). If not, suspect the main board. Otherwise probe pin 6 and 7 of J670 on the front panel board. If they are high and low, respectively, suspect the front panel, otherwise replace the cable.
3. When you press buttons on the front panel, do LEDs DS291 and DS292 on the main board flash? These LEDs monitor the transmit and receive lines on the main board side of the RS232 transceiver. If they flash, then go to step 5.
4. If DS291 is not flashing, then check pin 3 of J390 on the main board. When you press a key, you should see pulses about a 15 V high and 100 to 300  $\mu$ s long. If not, suspect the front panel board.
5. If pin 3 of J390 is toggling and DS291 is not, then the RS232 receiver on the main board is not working. Replace the main board.
6. If both DS291 and DS292 are flashing, then check pin 5 on main board connector J390. When a front panel button is pressed, the front panel sends a message to the main board via pin 3. The CPU on the main board responds via pin 5 and this instructs the front panel to change which LEDs on the front panel are illuminated. Pin 5 should have a burst of pulses with about 15 V signal swing and a basic pulse width of about 100  $\mu$ s. If there is no response from the CPU on pin 5 of main board connector J390, then the RS232 transmitter is bad; replace the main board.
7. If both the DS291 and DS292 LEDs are flashing and the signals at the main board connector are also good but the operation of the front panel is not correct, check the cable between the two boards. This can be done by probing pin 5 on J670 of the front panel board. As in step 5, it should have a burst of pulses about 15 V high and 100  $\mu$ s long after a button press. If the signal is bad, suspect the cable. If the signal is good, replace the front panel board.
8. If some buttons work, but others do not, then the front panel or the elastomeric key pads are bad. Disassemble the front panel assembly and use a small piece of wire or foil to emulate the carbon pad on the switch mat. If this registers as a switch closure then replace the elastomeric key pad. Otherwise replace the front panel board.
9. If some front panel button LEDs work and others do not, then the problem must be in the front panel board. These LEDs have the anodes connected to +5 V and the cathodes connected to a resistor driven by a logic gate. Probe

the voltage on the LED. If the LED is bad replace it, otherwise replace the front panel board.

10. The FAULT LED should be lit at power up for about 10 seconds. It should also be lit if either fan is stopped. If it is not lit at power up or when a fan is stopped, then check the voltage on the LED. The cathode connects to a 332 ohm resistor tied to ground and the anode connects to the output of a logic gate. If the voltage looks correct, then replace the LED, otherwise replace the front panel board.
11. If the buttons and LEDs work but knobs do not work, then replace the front panel.
12. If the buttons and LEDs work but the beeper does not sound, then replace the front panel board.
13. Check fuse F970 if the remote front panel is not functioning.

### **Audio POST Failure**

It is sometimes difficult to isolate the root cause of audio problems. Most audio problems are due to faults on the audio board, but the audio board communicates with the main board, so in some cases the problem may be there as well. This test isolates an audio POST failure to either the audio board, main board, or the cable between.

Not all errors are reported by the power up diagnostics; therefore, if you are detecting a loss in audio functionality, check the diagnostic log for any reported audio errors. If any errors are found, perform the following procedure to narrow the problem to either the audio board or the main board.

1. Prepare a test oscilloscope with the following settings:
  - a. Horizontal Scale 5.00  $\mu$ s/div
  - b. Vertical Scale 2.00 V/div
2. If the diagnostic log contains an entry that reads **Fail Audio DSP Self Test fpga**, do the following substeps:
  - a. Check the FPGA programmed indicator (DS0820 on the audio board). If this LED is off, skip to next step; otherwise probe pin 34 of connector J750 of the main board during the boot sequence. If the signal on the pin toggles, replace the main board; otherwise, probe pin 34 of J200 on the audio board. If the signal toggles on pin 34, replace the cable; otherwise, replace the audio board.
  - b. Probe pin 33 of J750 on the main board during the boot sequence. If the signal does not exhibit a low-to-high transition, replace the main board. If the signal does transition, check pin 33 of J200 on the audio board. If the signal does not toggle on pin 33, replace the cable.
  - c. Probe pins 31 and 32 of connector J750 during the boot sequence. If the signal on either of these pins does not toggle, replace the main board. If both signals do toggle, probe pins 31 and 32 on the audio board. If the signal does not toggle on either pin, suspect the cable.
  - d. Probe pin 30 of J200 on the audio board during the boot sequence. If the signal does not exhibit a low-to-high transition, replace the audio board. If the signal does transition, check pin 30 of connector J750 on the main board. If the signal on pin 30 does not toggle, suspect the cable; if the signal on pin 30 does toggle, suspect the audio board.
  - e. If all signals in a through d are correct replace the audio board.



3. If the Diagnostic Log screen reports the failure **Audio DSP Self Test—dsp0**, perform the following procedure:
  - a. Check to see if the audio board is recognized by the main board by pressing **CONFIG** and selecting **Utilities > View HW/SW Version**.
  - b. If there is an audio option listed, suspect the audio board; otherwise, proceed to next step.
  - c. Probe pins 3 through 14 on the main board connector J750, and verify that the signals on all pins are toggling. If any signals are not toggling, replace the main board. If they all are toggling, check them again on the audio board J200. If any of the signals do not toggle on the audio board, replace the cable.
  - d. Probe pins 15 and 18 on connector J750 during boot-up and verify that the signals toggle. If they are not toggling, suspect the main board. If they are toggling, check them again on the audio board J200. If either of the signals on pins 15 and 18 do not toggle on the audio board, replace the cable.
  - e. Probe pin 25 on the audio board connector J200 during the boot sequence. If the signal does not toggle, replace the audio board; otherwise, check it again on the main board at connector J750. If the signal on pin 25 does not toggle on the main board, then replace the cable; otherwise, replace the main board.
  - f. If all of these steps pass, replace the audio board.
4. If the Diagnostics Log reports the failure **Audio DSP Self Test—dsp1**, perform the following procedure:

Check to see if surround display is functioning correctly by doing the following.

  - a. Push the factory button, and then push and hold the display select #4 button.
  - b. In the audio pop-up menu, select **Aux Display>Surround Display**.
  - c. Also in the pop-up menu, select **Audio Input> AES A**.
  - d. Hook up an AES test tone generator to the AES A1-2 input.
5. If there is nothing displayed on the surround display, proceed to next step; otherwise, replace the audio board.
6. Probe pins 3 through 14 on the main board connector J750, and verify that the signals on all the pins are toggling. If any of the signals on pins 3 through 14 do not toggle, replace the main board. If they all do toggle, check them again on the audio board J200. If any of the signals on the pins do not toggle on the audio board, replace the cable.
7. Probe pins 15 and 20 on connector J750 during the boot sequence, and verify that the signals on the pins toggle. If they do not toggle, suspect the main

board. If the signals do toggle, check them again on the audio board J200. If any of the signals on the pins do not toggle on the audio board, replace the cable.

8. Probe pin 27 on the audio board connector J200. If the signal on the pin does not toggle, replace the audio board; otherwise, check it again on the main board connector J750. If the signal on pin 27 does not toggle on the main board, then replace the cable; otherwise, replace the main board.
9. If all of these steps pass, replace the audio board.

### **Isolating Advanced Diagnostic Lissajous Errors**

The advanced diagnostics test the lissajous data path between the audio and main boards. A failure in this data path can be due to problem on either board. Perform the following tests to isolate the problem to one board or the other.

If the advanced diagnostics detect an error in the Lissajous circuitry, then they will display a failure in the following categories:

- Lissajous Frequency : should be 61.44 MHz  $\pm$ 0.1 Mhz
- Lissajous Bus V2 : pass/fail

1. If there are any failures, prepare a test oscilloscope with the following settings:
  - a. Vertical Scale 2.00 V/div
  - b. Horizontal Scale 200 ns/div
2. If there is Lissajous Frequency failure, perform the following substeps:
  - a. Put the oscilloscope probe on pin 62 of connector J200 on the audio board. Verify the signal is  $\sim 3 V_{p-p}$  and is a continuous 50% duty-cycle squarewave.
  - b. If the signal at J940 is not as just described in the previous step, the audio board most likely has a failure; otherwise, proceed to next step.
  - c. With the oscilloscope probe, verify the signal at J750 pin 62 of the main board is as described in step a. If it not as described, suspect the cable; if it is as described, replace the main board.
3. If there is a Lissajous Bus V2 failure, perform the following substeps:
  - a. Put the scope probe on connector J200 pin 61 of the audio board and verify the signal is  $\sim 3 V_{p-p}$  and toggles low at regular intervals.
  - b. If the signal on pin 61 looks OK, put the scope probe on pin 63. Pin 63 is the data line and the signal will have a somewhat random look depending on the audio source. Just verify that the signal is toggling and is  $\sim 3 V_{p-p}$ .
  - c. If either signal looks bad at J200 the audio board most likely has a failure, otherwise continue to next step. With the scope probe, check the signal at pin 61 of J750 on the main board. Verify the signal is  $\sim 3 V_{p-p}$  and toggles low at regular intervals.
  - d. If the signal on pin 61 looks OK, put the scope probe on pin 63. Pin 63 is the data line and the signal will have a somewhat random look depending on the audio source. Verify that the signal is toggling and is  $\sim 3 V_{p-p}$ .
  - e. If either signal is bad, suspect the cable; otherwise replace the main board.

### Option EYE/PHY Troubleshooting

The EYE/PHY functions depend on the Loopthrough, EYE, and Main boards, and the interconnections between them.

---

**NOTE.** Options EYE and PHY are available only for the WVR7120 instrument.

---

**Major Operational or Diagnostic Failure.**

- Check that J6, the 60-pin connector between the Eye and Main boards, is correctly mated and secure.
- Check that the power supply cable is securely plugged into J3, the 2-pin connector on the Eye board.
- Check that the coaxial cables from the Loophrough board to the Eye board are securely connected and not crossed.

**Eye Pattern or Jitter Waveform Display Problems.** Jitter waveform display is only available with Option PHY. The Eye Pattern and Jitter Waveform displays are formed from data sampled from the input signal and the recovered clock sine wave. Eye display bandwidth, rise and fall time, and transient response aberrations depend on both the Eye and the Loophrough boards.

When the same signal is applied to both channels, a problem that appears on one channel but not the other indicates a faulty Loophrough board. If the problem appears on both channels, then suspect a faulty Eye board. It is possible, though, that both channels of the Loophrough board contain the same fault.

**Cable Loss, Approx Cable, and Source Level Readout Problems.** These measurements are made by a "cable meter" circuit. This circuit is located on the EYE board, but is largely independent from the Eye and Jitter display and measurement functions. If other EYE/PHY functions operate correctly, then a "cable meter" circuit problem is indicated.

**Jitter Readout and Jitter Meter Problems.** These measurements are derived from sampled recovered clock sine wave data. Operation is unlikely to fail if the basic Eye pattern display works correctly. Measurement accuracy is not adjustable, but jitter noise floor depends on adjustment of Eye HD CDR calibration items.

**Eye Amplitude, Eye Risetime, Eye Falltime, and Eye Rise-Fall (difference) Readout Problems.** These readouts are only available with Option PHY. These readouts are derived from the Eye pattern display. Measurement accuracy depends on the Eye Gain calibration items, and on front-end bandwidth and transient response, which are not adjustable. Operation is unlikely to fail if the basic Eye pattern display works correctly.

It is normal for these measurements to stop or become intermittent if there is excessive waveform noise, aberrations, jitter, or cable loss.

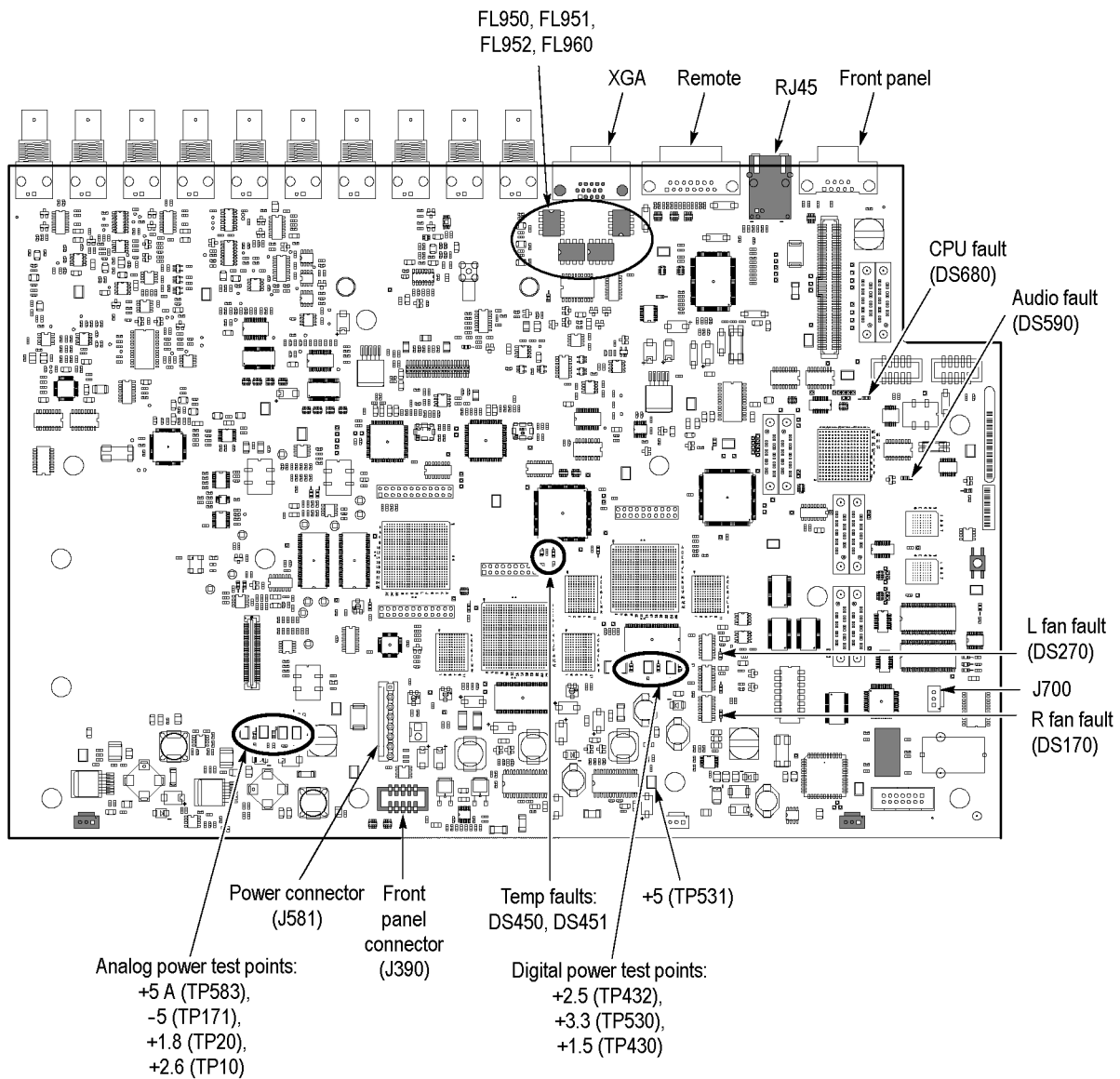

Figure 4-1: Main board indicator LED, connector, and test point locations

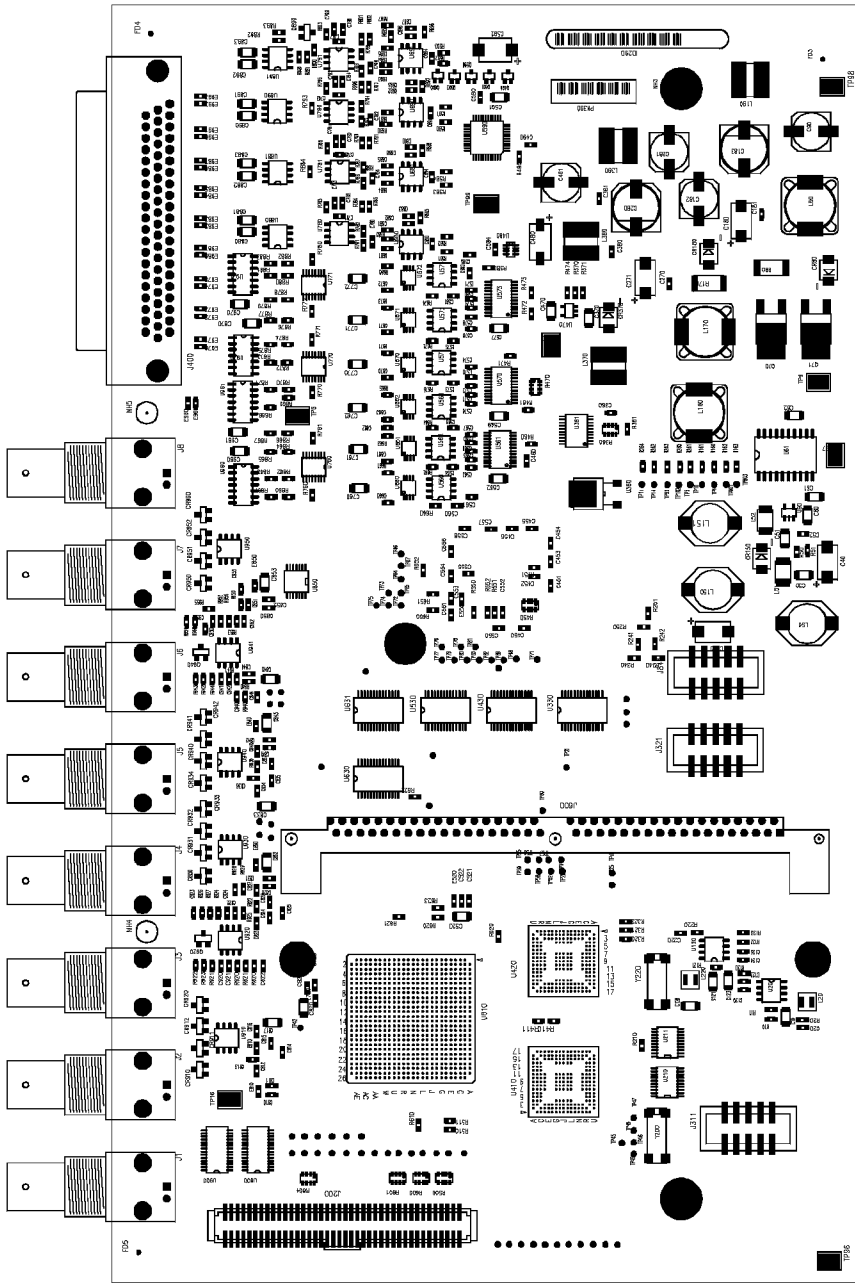

Figure 4-2: Options AD and DDE Audio board, component side

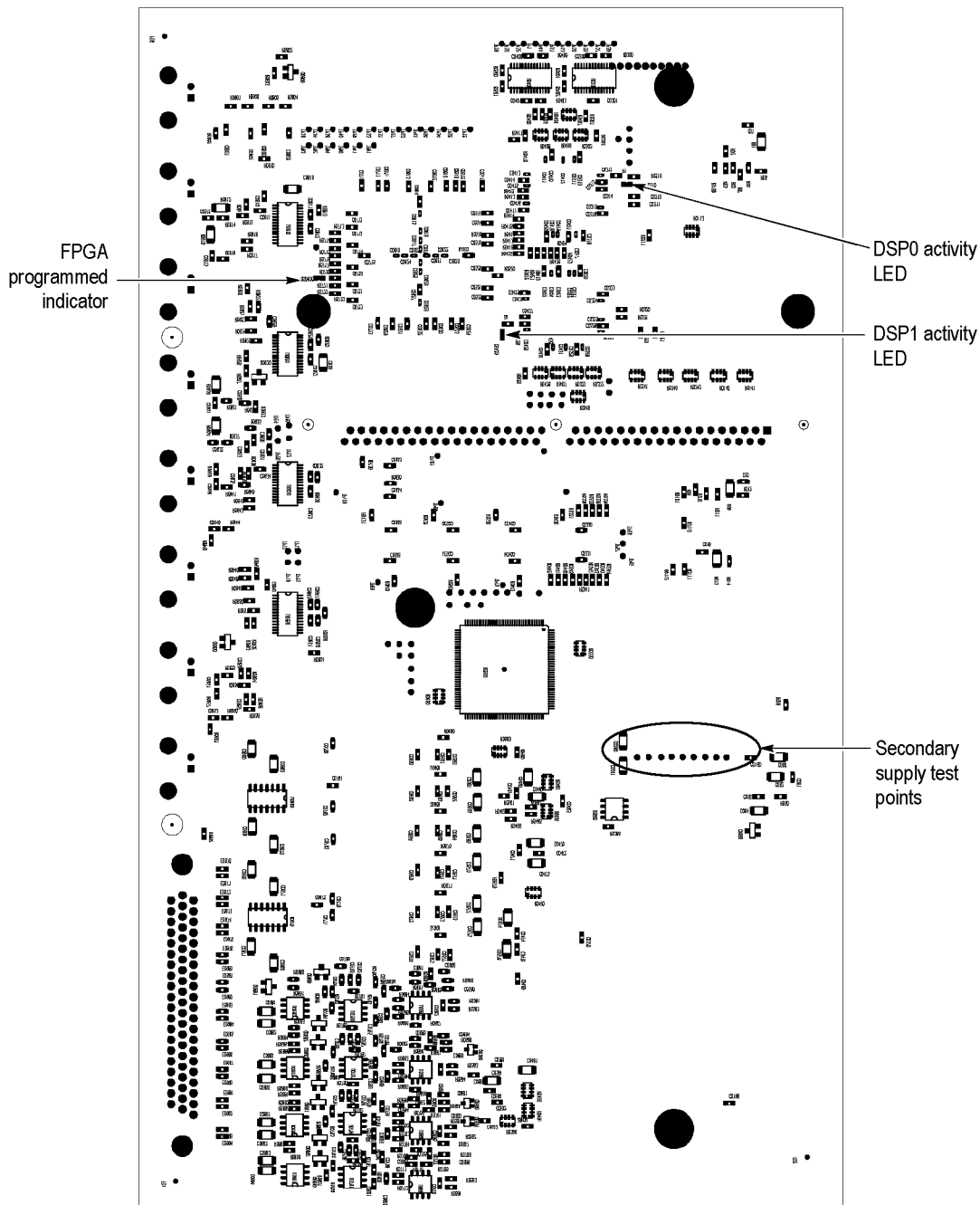
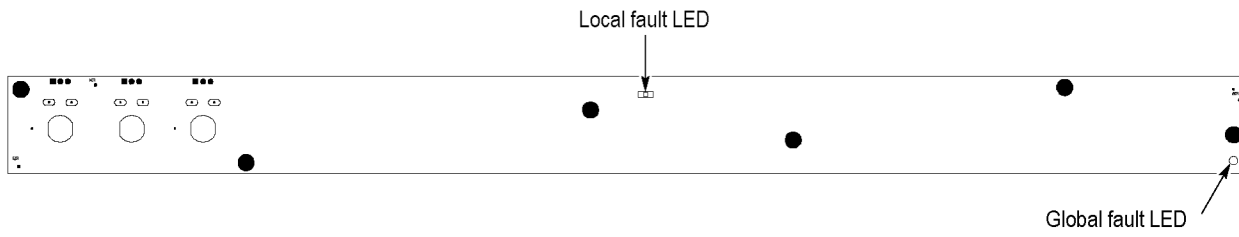

Figure 4-3: Options AD and DDE Audio board back side indicator LED and test point locations



**Figure 4-4: Front panel board indicator LED locations (viewed from back side)**



# Repackaging Instructions

This section contains the information needed to repack the waveform rasterizer for shipment or storage.

## Packaging

When repacking the instrument for shipment, use the original packaging. If the packaging is unavailable or unfit for use, contact your local Tektronix representative to obtain new packaging. Refer to *Contacting Tektronix*, following the copyright statement, for the mailing address, the email address, and phone number.

Seal the shipping carton with an industrial stapler or strapping tape.

## Shipping to the Service Center

Contact the Service Center to get an RMA (Return Material Authorization) number, and any return or shipping information you may need.

If the instrument is being shipped to a Tektronix Service Center, enclose the following information:

- The RMA number.
- The owner's address.
- Name and phone number of a contact person.
- Type and serial number of the instrument.
- Reason for returning.
- A complete description of the service required.

Mark the address of the Tektronix Service Center and the return address on the shipping carton in two prominent locations.



---

# Replaceable Mechanical Parts



---

# Replaceable Parts

This section contains a list of the replaceable modules and replaceable parts for the WVR6020, WVR7020, and WVR7120 Waveform Rasterizers. Use this list to identify and order replacement parts. Note that not all parts listed in this section are present on every model. The parts present will depend on the model and options installed.

## Parts Ordering Information

Replacement parts are available through your local Tektronix field office or representative.

Changes to Tektronix products are sometimes made to accommodate improved components as they become available and to give you the benefit of the latest improvements. Therefore, when ordering parts, it is important to include the following information in your order:

- Part number
- Instrument type or model number
- Instrument serial number
- Instrument modification number, if applicable

If you order a part that has been replaced with a different or improved part, your local Tektronix field office or representative will contact you concerning any change in part number.

### Module Servicing

Modules can be serviced by selecting one of the following three options. Contact your local Tektronix service center or representative for repair assistance.

**Module Exchange.** In some cases you may exchange your module for a remanufactured module. These modules cost significantly less than new modules and meet the same factory specifications. For more information about the module exchange program, call 1-800-833-9200. Outside North America, contact a Tektronix sales office or distributor; see the Tektronix Web site for a list of offices: [www.tektronix.com](http://www.tektronix.com).

**Module Repair and Return.** You may ship your module to us for repair, after which we will return it to you.

**New Modules.** You may purchase replacement modules in the same way as other replacement parts.

## Using the Replaceable Parts Lists

Use this list to identify and order replacement parts. The following table describes each column in the parts list.

Column	Column name	Description
1	Figure & index number	Items in this section are referenced by figure and index numbers to the exploded view illustrations that follow.
2	Tektronix part number	Use this part number when ordering replacement parts from Tektronix.
3 and 4	Serial number	Column three indicates the serial number at which the part was first effective. Column four indicates the serial number at which the part was discontinued. No entry indicates the part is good for all serial numbers.
5	Qty	This indicates the quantity of parts used.
6	Name & description	An item name is separated from the description by a colon (:). Because of space limitations, an item name may sometimes appear as incomplete. Use the U.S. Federal Catalog handbook H6-1 for further item name identification.

**Abbreviations**      Abbreviations conform to American National Standard ANSI Y1.1-1972.

Fig. & index number	Tektronix part number	Serial no. effective	Serial no. discont'd	Qty	Name & description
5-1					<b>CIRCUIT BOARDS AND CHASSIS</b>
-1	211-0734-00			16	SCREW,MACHINE; 6-32 X 0.250,FLH100,STL,CDPL,T-10 TORX DR
-2	200-4873-00			1	COVER; TOP,STANDARD INSTRUMENT,0.050 AL,SAFETY CONTROLLED
-3	671-6282-00			1	CIRCUIT BD ASSY; DUAL MAIN NO COMPOSITE,389-3789-00 WIRED,TESTED (WVR7020, WVR7120 ONLY)
	671-6249-00			1	CKT BD SUBASSY; DUAL MAIN WITH COMPOSITE, 389378900, WIRED,UNTESTED (WVR7020, WVR7120 ONLY)
	671-6043-02			1	CIRCUIT BD ASSY; MAIN,NO COMPOSITE,389-3789-00 WIRED,TESTED (WVR6020 ONLY)
	671-6100-02			1	CIRCUIT BD ASSY; MAIN WITH COMPOSITE,389-3789-00 WIRED,TESTED (WVR6020 ONLY)
-4	146-0116-00			1	BATTERY, DRY; 3.0V,850MAH,LITHIUM,0.57X1 INCHES;CR4250SE,SAFETY CONTROLLED
-5	131-4046-00			-	CONN,DSUB; PCB/PNL,FEMALE,RTANG,15 POS,0.318 MLG X 0.125 TAIL,4-40 THD INSERTS,BD RETENTION
-6	131-5450-00			-	CONN,DSUB; PCB,HIGH DENSITY;FEMALE,RTANG,15 POS,0.078 CTR,0.350 MLG X 0.125 TAIL,4-40 THD INSERT,BD RETENTION,30 GOLD,SAFETY CONTROLLED
-7	214-3903-00			6*	SCREW,JACK; 4-40 X 0.312 LONG,0.188 H HEX HEAD STAND OFF,4-40 INT THD, X 0.312 THD EXT 4-40
-8	131-4131-00			1	CONN,PLUG,ELEC; MALE W/LOCKING ADPTR,EXT MTG,SAFETY CONTROLLED
-9	211-0410-00			2	SCR,ASSEM WSHR; 4-40 X 0.437,PNH,STL,CDPL,T-10 TORX DR
-10	119-7086-00			1	FILTER,EMI; AC LINE CONNECTOR/INPUT FILTER;6.0A,120-250VAC,DC-400 HZ,2.2 NF CY,100 NF CX,IEC INPUT,FAST-ON/SOLDER LUG OUTPUT,CHASSIS MOUNT,SAFETY CONTROLLED;FN9222-6/06
-11	351-0104-03			1	SL SECT,DWR EXT; 12.625 L,W/O HARDWARE SAFETY CONTROLLED
-12	212-0158-00			8	SCREW,MACHINE; 8-32 X 0.375,PNH,STL,CDPL,T-20 TORX DR
-13	351-0751-01			1	TRK,SL OUT SECT; STATIONARY & INTERMEDIATE SAFETY CONTROLLED
-14	211-0721-00			4	SCREW,MACHINE; 6-32 X 0.375,PNH,STL,CDPL,T-15 TORX DR
-15	119-6801-00			1	POWER SUPPLY; 110W,AC-DC,5VDC 22A OUT,90-264VAC 47-63HZ IN,PFC,75% EFF,OPEN FRAME,6.5 X 3 X 1.26 IN,UL,CSA,VDE,SAFETY CONTROLLED
-16	311-2570-00			3	ENCODER; DIGITAL CONTACTING ENCODER; PCB MOUNT, .354 DIA HOLE,1.0 L X .25 DIA SHAFT, NO DETENTS, 36 COUNTS PER TURN. ECW1J-B32-SEO/058
-17	210-1039-00			6	WASHER,LOCK; 0.521 ID,INT,0.025 THK,SST
-18	671-5382-01			1	CIRCUIT BD ASSY; FRONT PANEL,TESTED,389-3257-00 WIRED
-19	366-0816-01			3	KNOB; SILVER GRAY, 0.420OD, 0.520H, PC/ABS BAYBLEND FR110,FRONT PANEL
-20	260-2774-01			1	SWITCH,KEYPAD; ELASTOMERIC,FRONT PANEL,PUSHBUTTON
-21	354-0025-00			1	RING,RETAINING; EXTERNAL,U/O 0.187 DIA SFT
-22	213-0216-00			1	THUMBSCREW; 10-32 X 0.85,0.375 OD HD,SST W/SLOT
-23	367-0530-00			2	HANDLE,BOW; AL,1.0 X 1.25,STAIN FINISH,SAFETY CONTROLLED

## Replaceable Parts

Fig. & index number	Tektronix part number	Serial no. effective	Serial no. discont'd	Qty	Name & description
-24	335-1835-00			1	MARKER,IDENT, FRONT PANEL ID W/O COMPOSITE, W/EYE, WVR7120
	335-1836-00			1	MARKER,IDENT, FRONT PANEL ID W/ COMPOSITE, W/EYE,WVR7120
	335-1837-00			1	MARKER,IDENT, FRONT PANEL ID W/O COMPOSITE, W/EYE,WVR7020
	335-1838-00			1	MARKER,IDENT, FRONT PANEL ID W/ COMPOSITE, W/EYE,WVR7020
	335-1839-00			1	MARKER,IDENT, FRONT PANEL ID W/O COMPOSITE, WVR6020
	335-1840-00			1	MARKER,IDENT, FRONT PANEL ID WITH COMPOSITE, WVR6020
-25	101-0160-01			1	TRIM RING; FRONT,19.000 X 1.718 X 0.345,PC/ABS
-26	441-2295-00			1	CHASSIS,FRONT; 0.050 AL,SAFETY CONTROLLED
-27	210-0457-00			7	NUT,PL,ASSEM WA; 6-32 X 0.312,STL CD PL,W/LOCKWASHER
-28	150-5009-00			1	DIODE,OPTO; LED;HI-EFFIC RED,626NM,3.4MCD AT 10MA;HLMP-6305-021, YOKE LEAD BEND, 12MM T&R
-29	211-0410-00			6 <sup>1</sup>	SCR,ASSEM WSHR; 4-40 X 0.437,PNH,STL,CDPL,T-10 TORX DR
-30	150-0277-00			46	LT EMITTING DIODE; GREEN, 570 NM, 1206, REVERSE MOUNT; APTD3216MGCK-01
-31	441-2362-00			1	CHASSIS,MAIN; STANDARD INSTRUMENT,0.050 AL,W/HARDWARE,SAFETY CONTROLLED
-32	211-0722-00			15	SCREW,MACHINE; 6-32 X 0.250,PNH,STL,CDPL,T-15 TORX DR
-33	337-4309-00			1	SHIELD; POWER SUPPLY,0.020 POLYCARBONATE,SAFETY CONTROLLED
-34	211-1161-00			8	SCREW,MACHINE; 4-40 X 1.500,PAN HEAD,T-10 TORX,ZINC PL
-35	119-7036-00			2	FAN ASSEMBLY; DC,12V;0.105A,8.6 CFM,30DBA,3 LEAD, TACH OUTPUT, WITH CONN & HOUSING,SAFETY CONTROLLED
-36	407-5010-00			1	BRACKET ASSY,FAN; 0.050 AL,SAFETY CONTROLLED
-37	671-9935-01			1	CIRCUIT BD ASSY; LOOP THROUGH,,389-3568-00,WIRED
-38	131-m057-00			1	CONN,RF:PCB,FEMALE,BNC,75OHM,EDGE LAUNCH TYPE
-39	131-3925-00			1	CONN,DSUB; PCB,FEMALE,RTANG,9 POS,0.112 CTR,0.318 MLG X 0.125 TAIL,4-40 THD INSERT,BD RETENTION,30 GOLD
-40	374-4371-00			1	SHIELD; POWER SUPPLY BOTTOM, 0.030 POLYCARBONATE, SAFETY CONTROLLED

<sup>1</sup> Quantity varies with instrument and audio option.



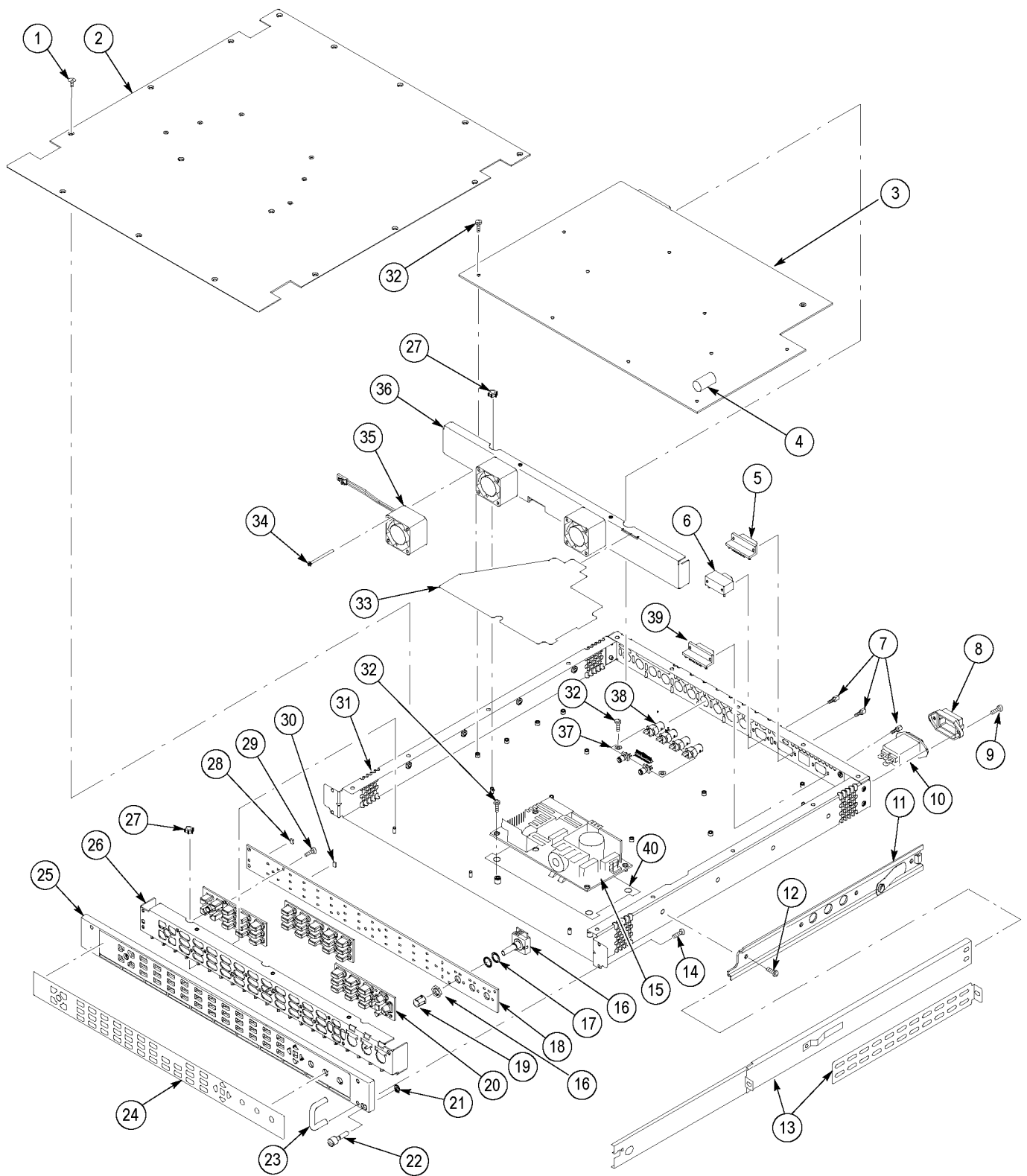

Figure 5-1: Replaceable parts, circuit boards and chassis

## Replaceable Parts

Fig. & index number	Tektronix part number	Serial no. effective	Serial no. discont'd	Qty	Name & description
5-2					<b>CABLES, CONNECTORS, ETC.</b>
-1	174-5224-00			1	CA ASSY,SP; PWR,BR;10.250 L;18 AWG;CONN HDR 1 X 8 AND CONN HDR 1 X12 AND 1X2;PWR SUPPLY TO MAIN BD AND EYE BDS
-2	174-4769-00			1	CA ASSY,SP; HV,BR,15.00 L & 4.00 L;CONN EACH END;LINE FILTER TO PWR SUPPLY,SAFETY CONTROLLED
-3	260-5012-00			1	SWITCH,DIP; SPST,SLIDE,DIP,4 POSITION,GOLD OVER NICKEL,0.4VA @ 20VDC,0.05 HALF PITCH;TD04H0SK1,SMD
-4	134-0246-00			12 <sup>1</sup>	PLUG,HOLE COVER; BUTTON PLUG.;0.578 HEAD DIA X 0.406 THK,ACCOM 0.5 DIA HOLE,0.015-0.125 THK PNL,NYLON,BLACK
-5	131-7270-00			10 <sup>1</sup>	CONN,RF PLUG; BNC,PCB,PNL MNT,FEMALE,RTANG,75 OHM, 0.510 H X 0.169 TAIL,LOW PROFILE ZINC DIE CAST HOUSING
-6	210-1039-00			10 <sup>1</sup>	WASHER,LOCK; 0.521 ID,INT,0.025 THK,SST
-7	220-0497-00			10 <sup>1</sup>	NUT,PLAIN,HEX; 0.5-28 X 0.562 HEX,BRS CD PL
-8	119-5067-00			4	FILTER,RFI; EMI, COMMON MODE CHOKE COIL; 2LINES, 200 OHM IMP, 20- 300MHZ, 50V, 0.5A; 8 PIN SMD; ZJYS51R5-4P
-9	131-7257-00			1	CONN,JACK; PCB/PNL,RJ45,CAT5,W/LEDS YELLOW & GREEN,FEMALE,RTANG,8 POS,0.1 CTR,0.528 H X 0.138 TAIL,10/100 BASE TX AND RX MAGNETICS MODULE,SAFETY CONTROLLED
-10	260-5015-00			1	SWITCH,PUSH; SPST,TACT;50MA,50V,MOMENTARY,SILVER CONTACTS;KSC221G,GULLWING SMD,T&R
-11	131-3572-00			1	CONN,HDR;; PCB,MALE,STR,2 X 7,0.1 CTR,0.385 H X 0.120 TAIL,SHRD/4 SIDES,CTR PLZ,30 GOLD,0.150 END DIM;,,
-12	260-5000-00			1	SWITCH,SLIDE; SPST;DIP8 POSITION,GOLD OVER NICKEL,3A,2PF,SEALED;90HBW08S
-13	150-1022-00			1	DISPLAY,OPTO; ,LED;RED,660NM,7SEG,0.3 INCH DISPLAY,125UCD PER SEGMENT AT10MA,COMMON ANODE,LEFT HAND DECIMAL;MAN72A
-14				1	FUSE; UL/IEC127, F3.15A H, 250VAC (5 x 20 mm)
-15	131-6187-00			1	CONN,HDR PWR; PCB,MALE,STR,1 X 8,0.156 CTR,0.450 MLG X 0.125 TAIL,PLZ WALL,TIN,SAFETY CONTROLLED
-16	131-7244-00			2	CONN,HDR; SMD,MALE,STR,2 X 5,0.100 CTR,0.350 H,0.165 MLG,SHRD/4 SIDES,MIL PLZ,30 GOLD,SAFETY CONTROLLED (ONE ON MAIN BOARD, ONE ON FRONT PANEL)
-17	131-5457-00			3	CONN,HDR; PCB,MALE,STR,1 X 3,0.10 CTR,0.535 H X 0.130 TAIL,SHRD/4 SIDES,CTR PLZ,LATCHING,BD RETENTION,30 GOLD,
-18	174-4771-00			1	CA ASSY,SP; IDC,RIBBON,10.00 L,DOUBLE ENDED,FEMALE,2 X 5 POS;F/P BD TO MAIN BD,SAFETY CONTROLLED
-19	200-4800-00			1	COVER,MINI; 2X FEX-440,SAFETY CONTROLLED
-20	210-0457-00				NUT,PL,ASSEM WA; 6-32 X 0.312,STL CD PL,W/LOCKWASHER
-21	211-0410-00				SCR,ASSEM WSHR; 4-40 X 0.437,PNH,STL,CDPL,T-10 TORX DR

<sup>1</sup> Quantity varies with instrument model.

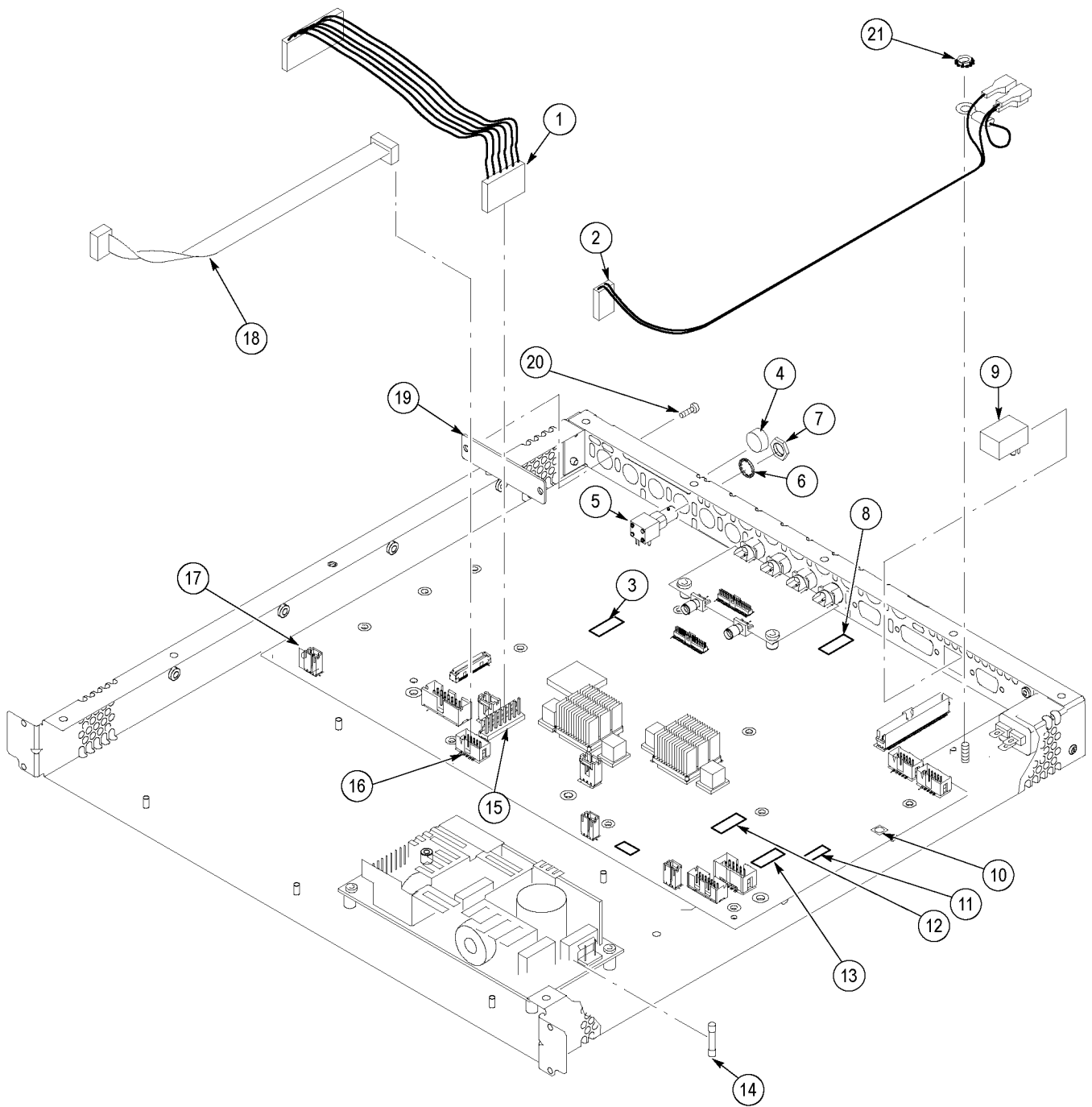

Figure 5-2: WVR6020, WVR7020, and WVR7120 replaceable cables, connectors, and other mechanical parts

## Replaceable Parts

Fig. & index number	Tektronix part number	Serial no. effective	Serial no. discont'd	Qty	Name & description
5-3					<b>MAIN BOARD</b>
-1	119-5067-00			4	FILTER,RFI; EMI,COMMON MODE CHOKE COIL;2LINES,200 0HM IMP,20- 300MHZ,50V,0.5A;8 PIN SMD;ZJYS51R5-4P
-2	131-7257-00			1	CONN,JACK; PCB/PNL,RJ45,CAT5,W/LEDS YELLOW & GREEN,FEMALE,RTANG,8 POS,0.1 CTR,0.528 H X 0.138 TAIL,10/100 BASE TX AND RX MAGNETICS MODULE,SAFETY CONTROLLED
-3	260-5015-00			1	SWITCH,PUSH; SPST,TACT;50MA,50V,MOMENTARY,SILVER CONTACTS;KSC221G,GULLWING SMD,T&R
-4	131-5457-00			3	CONN,HDR; PCB,MALE,STR,1 X 3,0.10 CTR,0.535 H X 0.130 TAIL,SHRD/4 SIDES,CTR PLZ,LATCHING,BD RETENTION,30 GOLD, SAFETY CONTROLLED
-5	150-5037-00			1	DIODE,OPTO; LED;GREEN,571NM,4.0 TO 9.0 MCD AT 20MA,155 DEG VIEW ANGLE,TINTED,DIFFUSED;HSMG-C170,SMD,0805,8MM T&R
-6	146-0116-00			1	BATTERY,DRY; 3.0V,850MAH,LITHIUM,0.57 X1.0;CR4250SE,SAFETY CONTROLLED
-7	260-5000-00			1	SWITCH,SLIDE; SPST;DIP8 POSITION,GOLD OVER NICKEL,3A,2PF,SEALED;90HBW08S,44MM T&R
-8	159-5010-00			2	FUSE,SMD; 7A,125V,FAST BLOW,0.1 X 0.1X 0.24;UL REG,CSA CERT,SAFETY CONTROLLED
-9	159-5022-00			3	FUSE; 5.0A,125V;FAST BLOW,0.1 X 0.1 X 0.24,UL REG,CSA CERT;451005,SAFETY CONTROLLED
-10	131-7244-00			3	CONN,HDR; SMD,MALE,STR,2 X 5,0.100 CTR,0.350 H,0.165 MLG,SHRD/4 SIDES,MIL PLZ,30 GOLD,SAFETY CONTROLLED
-11	159-5003-00			1	FUSE,THRM,CHIP; SELF RESETTING FUSE,1.1A HOLD,2.2A TRIP AT 20 DEG C,30V MAX,SAFETY CONTROLLED (MAIN)
-12	159-5008-00			2	FUSE,THRM,CHIP; SELF RESETTING FUSE,1.5A HOLD,3.0A TRIP AT 20 DEG C,30V MAX,SAFETY CONTROLLED (MAIN)

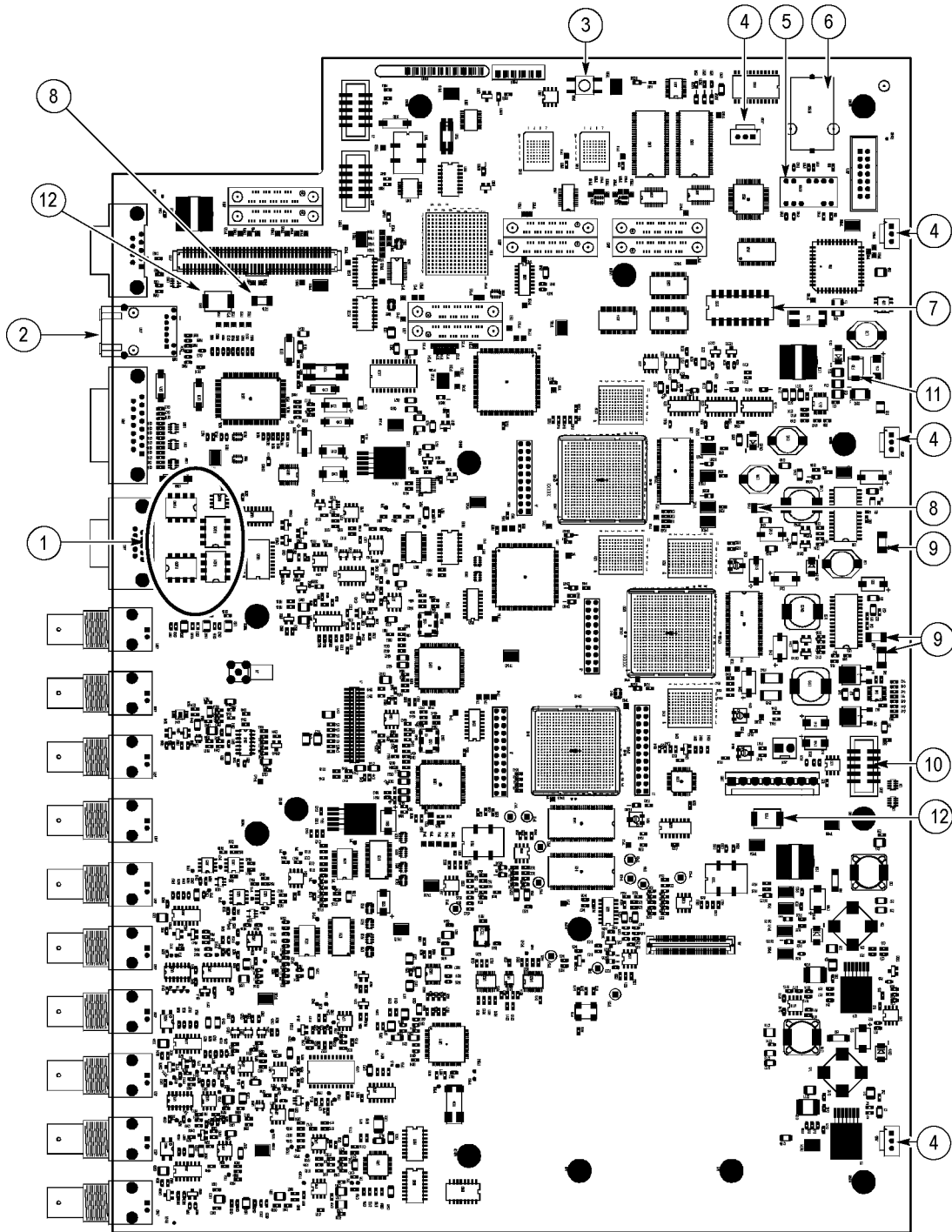

Figure 5-3: Main board replaceable components and connectors, WVR7020, WVR7120, and WVR6020

## Replaceable Parts

Fig. & index number	Tektronix part number	Serial no. effective	Serial no. discont'd	Qty	Name & description
5-4					<b>OPTIONS EYE/PHY AND AUDIO - BOARDS AND CONNECTORS</b>
-1	671-9938-02			1	CIRCUIT BD ASSY; DIGITAL ANALOG AUDIO, 389-3575-00 WIRED, TESTED WVR6020 & WVR7120 AUDIO OPTIONS ONLY.
-2	131-7270-00			8	CONN, RF, PLUG; BNC, PCB, PNL MNT, FEMALE, RTANG, 75 OHM, 0.510 H X 0.169 TAIL, LOW PROFILE ZINC DIE CAST HOUSING
-3	220-0497-00			8	NUT, PLAIN, HEX; 0.5-28 X 0.562 HEX, BRS CD PL
-4	210-1039-00			8	WASHER, LOCK; 0.521 ID, INT, 0.025 THK, SST
-5	174-4973-00			1	WVR6020 & WVR7120 OPTIONS AD & DDE ONLY. CABLE ASSY; 80 POS. CABLE WITH TWO 2X40 CONNECTORS
-6	131-7575-00			1	CONN, HDR; SMD, SYS50; MALE, STR, 2 X 40, 0.05 X 0.1 CTR, 0.480H, SHRD/4, CTR PLZ, LATCHING, 30 GOLD, SAFETY CONTROLLED
-7	129-0208-00			5	SPACER, POST; 0.312 L, 6-32 STUD, BRS, ELECTROLESS NICKEL, 0.25 HEX (OPTIONS EYE AND PHY ONLY)
-8	664-6099-00			1	CIRCUIT BD. SUB ASSY; SD, EYE BOARD, FUNCTIONAL BD. TEST LEVEL 389-3569-00, WIRED (WVR6020, OPTIONS EYE AND PHY ONLY )
-8	664-9936-00			1	CIRCUIT BD. SUB ASSY; HD/SD EYE BOARD, FUNCT BD. TEST LEVEL, 389-3569-00 WIRED (WVR7120, OPTIONS EYE AND PHY ONLY)
-9	174-5301-00			2	CABLE ASSY ELEC: RF, 50 OHM COAX, SMA/PLUG/ST (OPTIONS EYE AND PHY ONLY)
-10	119-7167-00			1	WVR6020 & WVR7120 OPTION DDE ONLY. CIRCUIT BD ASSY; CAT552 DOLBY E/DIGITAL DECODER MODULE; 72 PIN SIMM; SAFETY CONTROLLED
-11	129-1570-00			3	POST, SPACER; 1.385 X 0.250 X 0.375 DEEP
-12	131-7430-00			1	WVR6020 & WVR7120 OPTIONS AD & DDE ONLY.. CONN, DSUB; SLDR CUP, MALE, STR, 62 POS, 0.100 CTR, 30 GOLD
-13	214-3903-00			2	SCREW, JACK; 4-40 X 0.312 LONG, 0.188 H HEX HEAD STAND OFF, 4-40 INT THD, X 0.312 THD EXT 4-40
not shown	174-4281-00			2	CA ASSY, SP; FLAT RIBBON, IDC, 30 AWG, 6.100L, 40 POS, -DUBLIN, SAFETY CONTROLLED
not shown	200-4800-00			1	COVER, MINI; 2X FEX-440, SAFETY CONTROLLED
not shown	174-4586-00			1	CA ASSY; RIBBON, 2.0 L, DOUBLE ENDED, IDC, FEMALE, 2 X 20, 0.050 CTR, PLZ

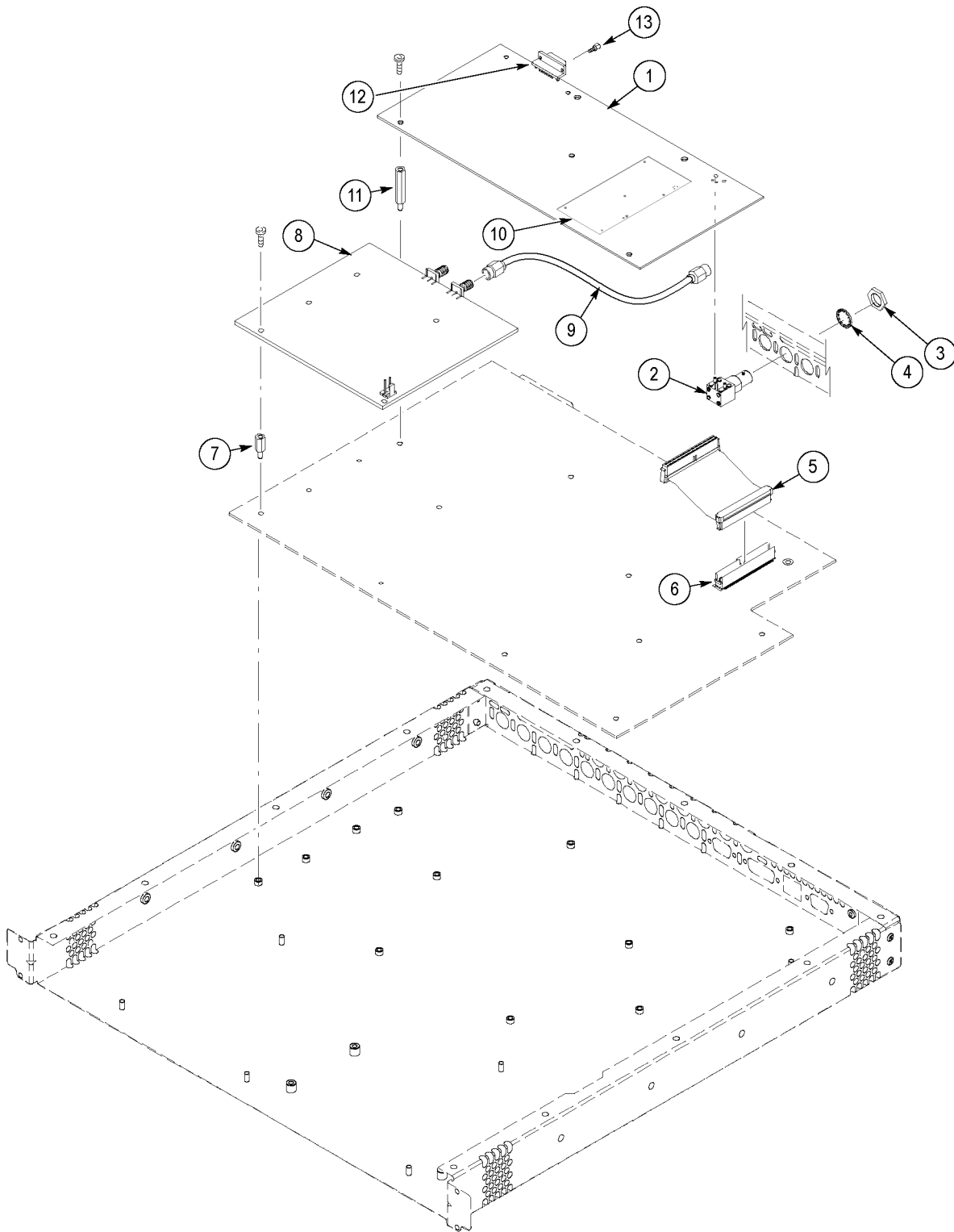

Figure 5-4: Option EYE/PHY and Audio Options boards and connectors

## Replaceable Parts

---

Fig. & index number	Tektronix part number	Serial no. effective	Serial no. discont'd	Qty	Name & description
5-5					<b>AUDIO BOARD - FRONT</b>
-1	276-5012-00			*	PB-FREE;EMI SUPPRESSION; FERRITE BEAD;120 OHMS@100MHZ, IMAX=200MA, DCR<0.2 OHM;BLM11A121SPT, 0603, 7 INCH T&R
-2	131-7272-00			1	CONN, DSUB; PCB/PNL, FEMALE, 62 POS, RTANG, 0.100 CTR, 0.495 H X 0.125 TAIL, 30 GOLD, 4-40 THD INSERTS, BOARD RETENTION, HIGH DENSITY CONN
-3	136-1435-00			1	SOCKET, SIMM; PCB, FEMALE, RTANG, 1 X 72, 0.05 CTR, 0.448 H X 0.11 TAIL, LEFT POLARIZED, 30 GOLD
-4	131-7575-00			1	CONN, HDR; SMD, SYS50;MALE, STR, 2 X 40, 0.05 X 0.1 CTR, 0.480H, SHRD/4, CTR PLZ, LATCHING, 30 GOLD, SAFETY CONTROLLED

\* Count varies with option



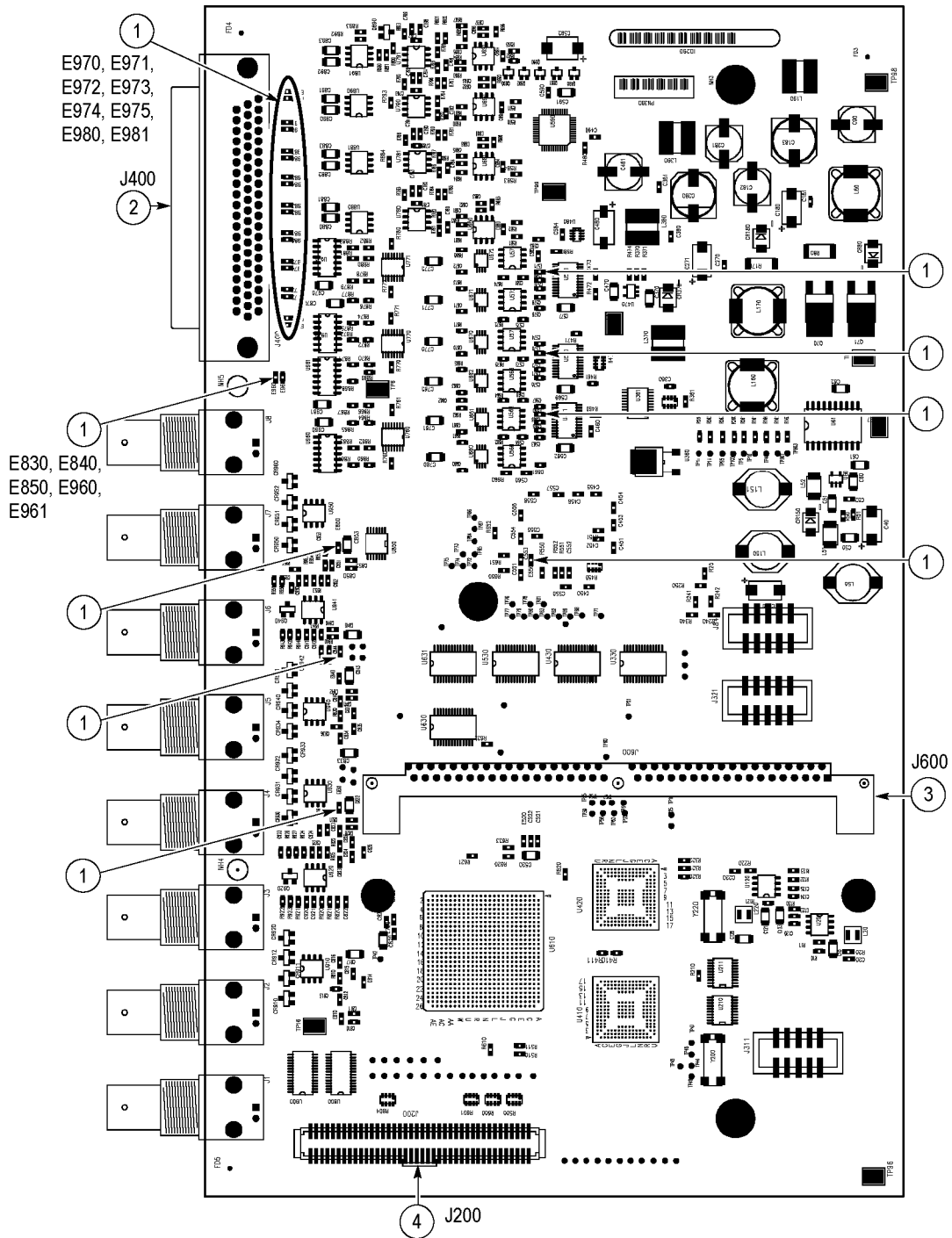

Figure 5-5: Audio board component-side components, Options AD and DDE

## Replaceable Parts

---

<b>Fig. &amp; index number</b>	<b>Tektronix part number</b>	<b>Serial no. effective</b>	<b>Serial no. discont'd</b>	<b>Qty</b>	<b>Name &amp; description</b>
5-6					<b>AUDIO BOARD - BACK</b>
-1	276-5012-00			20	PB-FREE; EMI SUPPRESSION; FERRITE BEAD;120 OHMS@100MHZ, IMAX=200MA, DCR<0.2 OHM;BLM11A121SPT, 0603, 7 INCH T&R

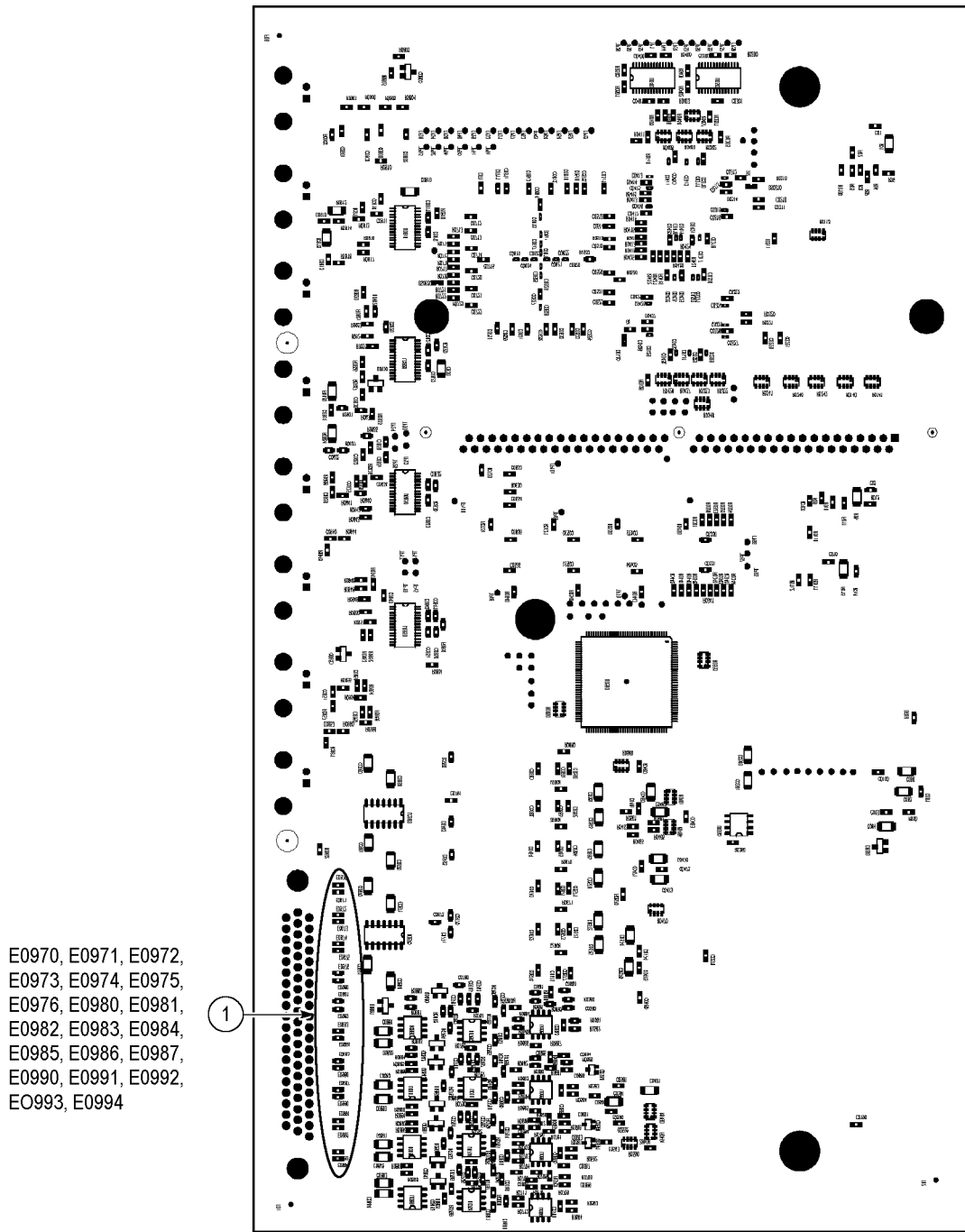
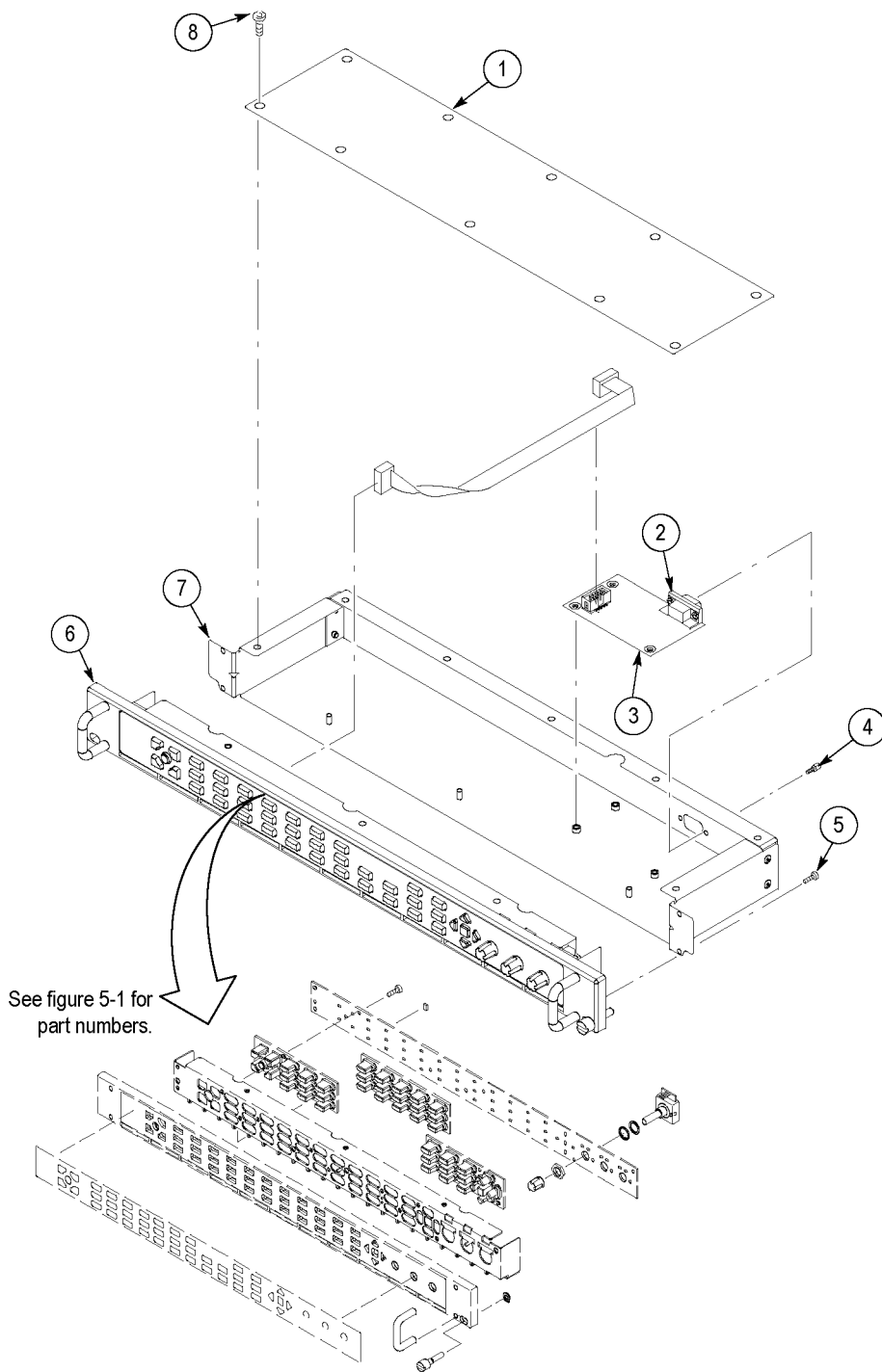

Figure 5-6: Audio board back-side components, Options AD and DDE

## Replaceable Parts

---

Fig. & index number	Tektronix part number	Serial no. effective	Serial no. discont'd	Qty	Name & description
5-7					<b>WVRRFP</b>
-1	200-4874-00			1	COVER; TOP TO REMOTE FRONT PANEL,0.050 AL,SAFETY CONTROLLED
-2	131-3295-00			1	CONN,RCPT,ELEC; HEADER,2 X 25,0.1 SPACING
-3	389-3574-00			1	CIRCUIT BOARD; FRONT PANEL REGULATOR,SAFETY CONTROLLED
	671-9937-00			1	CIRCUIT BD ASSY; FRONT PANEL REGULATOR,389-3574-00 WIRED,TESTED
-4	214-3903-00			-	SCREW,JACK; 4-40 X 0.312 LONG,0.188 H HEX HEAD STAND OFF,4-40 INT THD, X 0.312 THD EXT 4-40
-5	211-0721-00			-	SCREW,MACHINE; 6-32 X 0.375,PNH,STL,CDPL,T-15 TORX DR
-6	441-2295-00			1	CHASSIS,FRONT; REMOTE FRONT PANEL,0.050 AL
-7	441-2361-00			1	CHASSIS,MAIN; REMOTE FRONT PANEL,,0.050 AL,W/HARDWARE,SAFETY CONTROLLED



**Figure 5-7: WVRFP**

## Replaceable Parts

Fig. & index number	Tektronix part number	Serial no. effective	Serial no. discont'd	Qty	Name & description
5-8					<b>ANALOG AUDIO BREAKOUT CABLE - OPTIONAL ACCESSORY</b>
-1	012-1688-00			1	WVR7020, WVR7120 AND WVR6020 WITH OPTIONS AD AND DDE ONLY. CABLE ASSEMBLY; ANALOG/AUDIO BREAKOUT
-2	200-4804-00			1	COVER; SHIELD,ELEC CONN,37 POS DSUB,ZINC
-3	131-0422-00			1	CONN,DSUB; SLDR CUP/PNL,;MALE,STR,37 POS,0.112 CTR,0.186 H X 0.126 TAIL,0.125 DIA THRU MTG

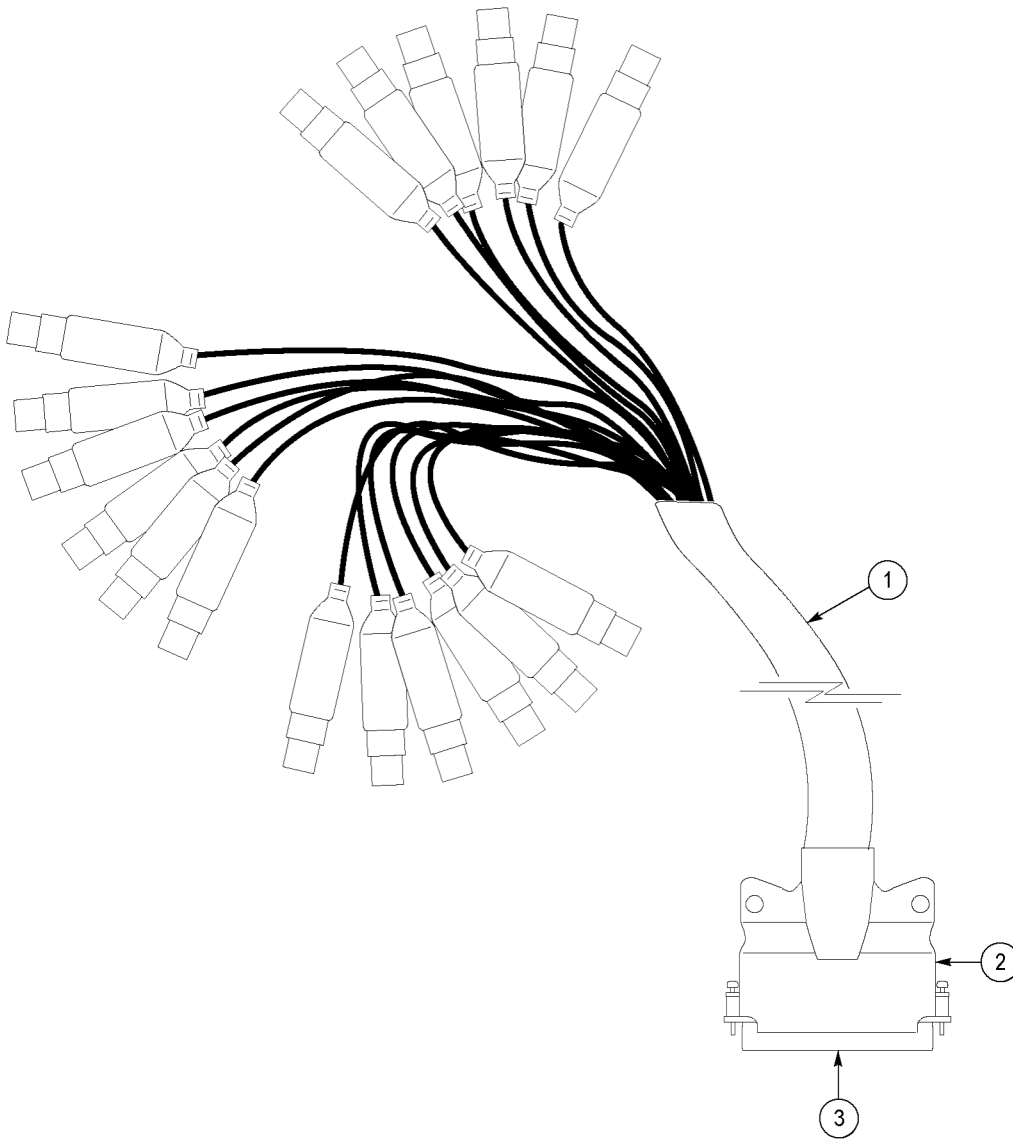

**Figure 5-8: Analog audio breakout cable assembly**

Fig. & index number	Tektronix part number	Serial no. effective	Serial no. discont'd	Qty	Name & description																											
<b>STANDARD ACCESSORIES</b>																																
	071-2231-xx			1	MANUAL, TECH;QUICK START USER MANUAL, ENGLISH, WVR6020/WVR7020/WVR7120 (OPTION L0 ONLY)																											
	071-2232-xx			1	MANUAL, TECH;QUICK START USER MANUAL, JAPANESE, WVR6020/WVR7020/WVR7120 (OPTION L5 ONLY)																											
	071-2233-xx			1	MANUAL, TECH;QUICK START USER MANUAL, SIMPLIFIED CHINESE, WVR6020/WVR7020/WVR7120 (OPTION L7 ONLY)																											
	071-2238-xx			1	MANUAL, TECH;RELEASE NOTES, WVR6020/WVR7020/WVR7120																											
	063-4056-xx			1	DOCUMENTATION;PRODUCT CD, ENGLISH, WVR6020/WVR7020/WVR7120																											
	See Description			1	CABLE ASSY, POWER:																											
					<table border="1"> <thead> <tr> <th><u>OPTION</u></th> <th><u>COUNTRY</u></th> <th><u>P/N</u></th> </tr> </thead> <tbody> <tr> <td>A0</td> <td>N. AMERICA</td> <td>161-0066-00</td> </tr> <tr> <td>A1</td> <td>UNIV EURO</td> <td>161-0066-09</td> </tr> <tr> <td>A2</td> <td>UK</td> <td>161-0066-10</td> </tr> <tr> <td>A3</td> <td>AUSTRALIA</td> <td>161-0066-13</td> </tr> <tr> <td>A4</td> <td>USA 240V</td> <td>161-0066-12</td> </tr> <tr> <td>A5</td> <td>SWITZERLAND</td> <td>161-0154-00</td> </tr> <tr> <td>A6</td> <td>JAPAN</td> <td>161-A008-00</td> </tr> <tr> <td>A10</td> <td>CHINA</td> <td>161-0304-00</td> </tr> </tbody> </table>	<u>OPTION</u>	<u>COUNTRY</u>	<u>P/N</u>	A0	N. AMERICA	161-0066-00	A1	UNIV EURO	161-0066-09	A2	UK	161-0066-10	A3	AUSTRALIA	161-0066-13	A4	USA 240V	161-0066-12	A5	SWITZERLAND	161-0154-00	A6	JAPAN	161-A008-00	A10	CHINA	161-0304-00
<u>OPTION</u>	<u>COUNTRY</u>	<u>P/N</u>																														
A0	N. AMERICA	161-0066-00																														
A1	UNIV EURO	161-0066-09																														
A2	UK	161-0066-10																														
A3	AUSTRALIA	161-0066-13																														
A4	USA 240V	161-0066-12																														
A5	SWITZERLAND	161-0154-00																														
A6	JAPAN	161-A008-00																														
A10	CHINA	161-0304-00																														