

Model 3762 10-Channel High Voltage Multiplexer Card

User's Manual

3762-900-01 Rev. A / July 2017



3762-900-01A

Model 3762

10-Channel High Voltage Multiplexer Card

User's Manual

© 2017, Keithley Instruments

Cleveland, Ohio, U.S.A.

All rights reserved.

Any unauthorized reproduction, photocopy, or use of the information herein, in whole or in part, without the prior written approval of Keithley Instruments is strictly prohibited.

These are the original instructions in English.

All Keithley Instruments product names are trademarks or registered trademarks of Keithley Instruments. Other brand names are trademarks or registered trademarks of their respective holders.

Microsoft, Visual C++, Excel, and Windows are either registered trademarks or trademarks of Microsoft Corporation in the United States and/or other countries.

Document number: 3762-900-01 Rev. A / July 2017

The following safety precautions should be observed before using this product and any associated instrumentation. Although some instruments and accessories would normally be used with nonhazardous voltages, there are situations where hazardous conditions may be present.

This product is intended for use by personnel who recognize shock hazards and are familiar with the safety precautions required to avoid possible injury. Read and follow all installation, operation, and maintenance information carefully before using the product. Refer to the user documentation for complete product specifications.

If the product is used in a manner not specified, the protection provided by the product warranty may be impaired.

The types of product users are:

Responsible body is the individual or group responsible for the use and maintenance of equipment, for ensuring that the equipment is operated within its specifications and operating limits, and for ensuring that operators are adequately trained.

Operators use the product for its intended function. They must be trained in electrical safety procedures and proper use of the instrument. They must be protected from electric shock and contact with hazardous live circuits.

Maintenance personnel perform routine procedures on the product to keep it operating properly, for example, setting the line voltage or replacing consumable materials. Maintenance procedures are described in the user documentation. The procedures explicitly state if the operator may perform them. Otherwise, they should be performed only by service personnel.

Service personnel are trained to work on live circuits, perform safe installations, and repair products. Only properly trained service personnel may perform installation and service procedures.

Keithley Instruments products are designed for use with electrical signals that are measurement, control, and data I/O connections, with low transient overvoltages, and must not be directly connected to mains voltage or to voltage sources with high transient overvoltages. Measurement Category II (as referenced in IEC 60664) connections require protection for high transient overvoltages often associated with local AC mains connections. Certain Keithley Instruments measuring instruments may be connected to mains. These instruments will be marked as category II or higher.

Unless explicitly allowed in the specifications, operating manual, and instrument labels, do not connect any instrument to mains.

Exercise extreme caution when a shock hazard is present. Lethal voltage may be present on cable connector jacks or test fixtures. The American National Standards Institute (ANSI) states that a shock hazard exists when voltage levels greater than 30 V RMS, 42.4 V peak, or 60 VDC are present. A good safety practice is to expect that hazardous voltage is present in any unknown circuit before measuring.

Operators of this product must be protected from electric shock at all times. The responsible body must ensure that operators are prevented access and/or insulated from every connection point. In some cases, connections must be exposed to potential human contact. Product operators in these circumstances must be trained to protect themselves from the risk of electric shock. If the circuit is capable of operating at or above 1000 V, no conductive part of the circuit may be exposed.

Do not connect switching cards directly to unlimited power circuits. They are intended to be used with impedance-limited sources. NEVER connect switching cards directly to AC mains. When connecting sources to switching cards, install protective devices to limit fault current and voltage to the card.

Before operating an instrument, ensure that the line cord is connected to a properly-grounded power receptacle. Inspect the connecting cables, test leads, and jumpers for possible wear, cracks, or breaks before each use.

When installing equipment where access to the main power cord is restricted, such as rack mounting, a separate main input power disconnect device must be provided in close proximity to the equipment and within easy reach of the operator.

For maximum safety, do not touch the product, test cables, or any other instruments while power is applied to the circuit under test. ALWAYS remove power from the entire test system and discharge any capacitors before: connecting or disconnecting cables or jumpers, installing or removing switching cards, or making internal changes, such as installing or removing jumpers.

Do not touch any object that could provide a current path to the common side of the circuit under test or power line (earth) ground. Always make measurements with dry hands while standing on a dry, insulated surface capable of withstanding the voltage being measured.

For safety, instruments and accessories must be used in accordance with the operating instructions. If the instruments or accessories are used in a manner not specified in the operating instructions, the protection provided by the equipment may be impaired.

Do not exceed the maximum signal levels of the instruments and accessories. Maximum signal levels are defined in the specifications and operating information and shown on the instrument panels, test fixture panels, and switching cards.

When fuses are used in a product, replace with the same type and rating for continued protection against fire hazard.

Chassis connections must only be used as shield connections for measuring circuits, NOT as protective earth (safety ground) connections.

If you are using a test fixture, keep the lid closed while power is applied to the device under test. Safe operation requires the use of a lid interlock.

If a  screw is present, connect it to protective earth (safety ground) using the wire recommended in the user documentation.

The  symbol on an instrument means caution, risk of hazard. The user must refer to the operating instructions located in the user documentation in all cases where the symbol is marked on the instrument.

The  symbol on an instrument means warning, risk of electric shock. Use standard safety precautions to avoid personal contact with these voltages.

The  symbol on an instrument shows that the surface may be hot. Avoid personal contact to prevent burns.

The  symbol indicates a connection terminal to the equipment frame.

If this  symbol is on a product, it indicates that mercury is present in the display lamp. Please note that the lamp must be properly disposed of according to federal, state, and local laws.

The **WARNING** heading in the user documentation explains dangers that might result in personal injury or death. Always read the associated information very carefully before performing the indicated procedure.

The **CAUTION** heading in the user documentation explains hazards that could damage the instrument. Such damage may invalidate the warranty.

The **CAUTION** heading with the  symbol in the user documentation explains hazards that could result in moderate or minor injury or damage the instrument. Always read the associated information very carefully before performing the indicated procedure. Damage to the instrument may invalidate the warranty.

Instrumentation and accessories shall not be connected to humans.

Before performing any maintenance, disconnect the line cord and all test cables.

To maintain protection from electric shock and fire, replacement components in mains circuits — including the power transformer, test leads, and input jacks — must be purchased from Keithley Instruments. Standard fuses with applicable national safety approvals may be used if the rating and type are the same. The detachable mains power cord provided with the instrument may only be replaced with a similarly rated power cord. Other components that are not safety-related may be purchased from other suppliers as long as they are equivalent to the original component (note that selected parts should be purchased only through Keithley Instruments to maintain accuracy and functionality of the product). If you are unsure about the applicability of a replacement component, call a Keithley Instruments office for information.

Unless otherwise noted in product-specific literature, Keithley Instruments instruments are designed to operate indoors only, in the following environment: Altitude at or below 2,000 m (6,562 ft); temperature 0 °C to 50 °C (32 °F to 122 °F); and pollution degree 1 or 2.

To clean an instrument, use a cloth dampened with deionized water or mild, water-based cleaner. Clean the exterior of the instrument only. Do not apply cleaner directly to the instrument or allow liquids to enter or spill on the instrument. Products that consist of a circuit board with no case or chassis (e.g., a data acquisition board for installation into a computer) should never require cleaning if handled according to instructions. If the board becomes contaminated and operation is affected, the board should be returned to the factory for proper cleaning/servicing.

Safety precaution revision as of June 2017.

Table of contents

Introduction.....	1-1
Your multiplexer card	1-1
System switch / multimeter card compatibility	1-1
Extended warranty	1-2
Series 3700A documentation	1-2
Contact information	1-2
General information.....	1-2
Specifications	1-3
Installation and connections.....	2-1
Handling precautions	2-1
Unpack and inspect.....	2-1
Card connectors	2-2
Card installation	2-2
General operation	3-1
General operation	3-1
Safety hazards	3-1
Wire selection and preparation.....	3-2
Wiring.....	3-3
Installation and removal	3-3
Operation considerations.....	4-1
Cables	4-1
External factors	4-1
Reactive loads.....	4-2
Capacitive loads.....	4-2
Inductive loads	4-3
Make a modification	4-3
Typical applications.....	5-1
Model 3762 typical applications	5-1
Shielded application	5-1
Guarded application	5-2
Driven guard application	5-2
Four-wire application.....	5-3
Switch terminology.....	6-1
Switch terminology	6-1

Index I-1

Introduction

In this section:

Your multiplexer card	1-1
System switch / multimeter card compatibility	1-1
Extended warranty	1-2
Series 3700A documentation	1-2
Contact information	1-2
General information	1-2
Specifications	1-3

Your multiplexer card

Thank you for choosing a Keithley Instruments product. The Model 3762 is a 10-channel high-voltage card that is capable of switching voltages to 1000 V peak or currents to 0.5 A. The current carry capacity of each relay contact is 1 A. Two-pole channels switch both circuit high and low for full floating measurements. A guard input common to all channels is provided for shielding or as a guard driven from a single instrument.

Guards may be isolated by removing jumpers installed at each input. Multiple switched guard circuits can be achieved by removing the jumper and connecting circuit guard to the low input terminal.

System switch / multimeter card compatibility

The following table lists the cards that are compatible with the 3706 and 3706A.

Mainframe System Switch / Multimeter	Compatible plug-in cards
Model 3706	3720, 3721, 3722, 3723, 3724, 3730, 3731, 3732, 3740, 3750
Model 3706A	All plug-in cards compatible with the 3706A mainframe, plus the following card models: <ul style="list-style-type: none"> • 3760 • 3761 • 3762 • 3765

NOTE

The 3762 is designed for use only with the Model 3706A System Switch / Multimeter. Using the 3762 with the Model 3706 mainframe can cause unpredictable behavior.

Extended warranty

Additional years of warranty coverage are available on many products. These valuable contracts protect you from unbudgeted service expenses and provide additional years of protection at a fraction of the price of a repair. Extended warranties are available on new and existing products. Contact your local Keithley Instruments office, sales partner, or distributor for details.

Series 3700A documentation

Complete documentation for the Series 3700A System Switch/Multimeter instruments is available at the [Keithley Instruments website](http://www.tek.com/keithley) (<http://www.tek.com/keithley>). The following is a list of available documentation.

Document number	Document name	Content description
3700AS-903-01	Series 3700A System Switch/Multimeter Quick Start Guide	Hardware and software requirements, switching card installation instructions, and a brief description of front-panel and remote interface operation.
3700AS-900-01	Series 3700A System Switch/Multimeter User's Manual	Information about scanning, reading, writing, and controlling channels.
3700AS-901-01	Series 3700A System Switch/Multimeter Reference Manual	Information about controlling the Series 3700A from a remote interface.

Contact information

If you have any questions after you review the information in this documentation, please contact your local Keithley Instruments office, sales partner, or distributor. You can also call the corporate headquarters of Keithley Instruments (toll-free inside the U.S. and Canada only) at 1-800-935-5595, or from outside the U.S. at +1-440-248-0400. For worldwide contact numbers, visit the [Keithley Instruments website](http://www.tek.com/keithley) (<http://www.tek.com/keithley>).

General information

General ratings for the 3762 are listed in the following table:

Category	Specification
Maximum signal levels	Voltage: 1000 V peak
	Carry current: 1 A, peak or DC
	Switching current: 0.5 A, RMS or DC
	Switching power: 10 W

Common mode voltage	1000 V peak
Environmental conditions	<p>Indoor use only</p> <p>Operating: 0 °C to 50 °C (32 °F to 122 °F), 70% relative humidity up to 35 °C (95 °F); derate 3% relative humidity per °C, 35 °C to 50 °C, noncondensing</p> <p>Storage: -25 °C to 65 °C (-13 °F to 149 °F)</p> <p>Altitude: 0 to 2000 m (0 to 6562 feet) above sea level</p> <p>Pollution degree: 2</p>

The 3762 is a two-pole high-voltage multiplexer card that switches signal levels up to 1000 V, 0.5 A or 10 VA peak (10 mA at 1000 V) for resistive loads only. Each of the 10 channels on the card consists of two single-pole relays combined to create a normally open, double-pole, two-form A channel with a user selectable shield or driven guard connection. The output connection and the input connections have screw terminals with a maximum allowable wire size No. 16. The schematic representation is shown in the next figure.

Figure 1: Model 3762 simplified schematic

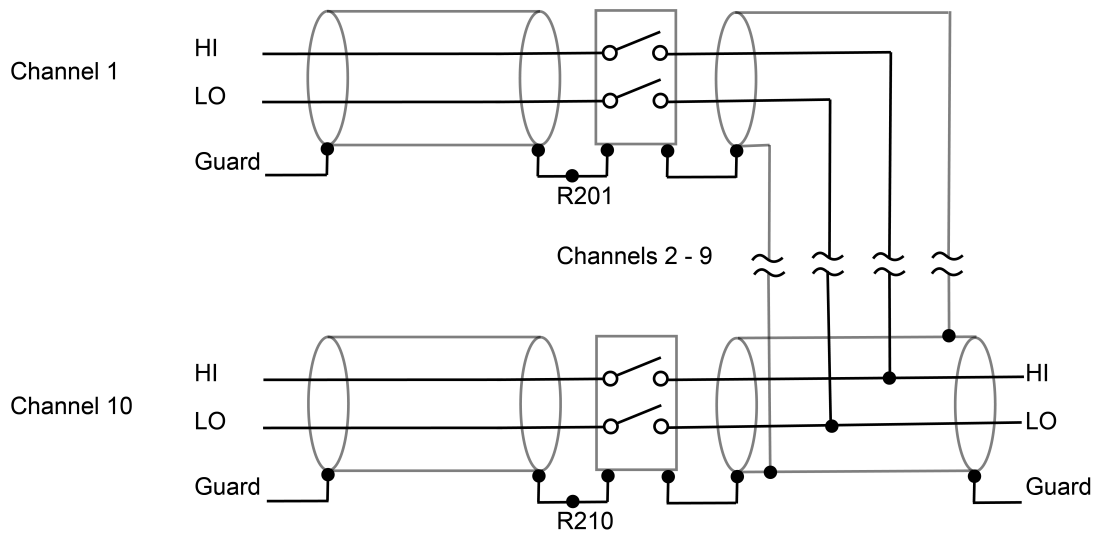

Switching is done in less than 2 milliseconds, exclusive of the mainframe, and the specified contact life is $>10^6$ closures with cold switching and $>1 \times 10^6$ closures at 1000 V/1 ma. The relay drive current is 80 mA per channel (40 mA per relay).

The 3762 is field installable in an appropriate Keithley Series 3700A Systems Switch Multimeter (for example, Model 3700A). With the isolation between each channel being greater than $10^{10} \Omega$ and less than 10 pF, each channel is well insulated from cross-channel noise and interference.

Specifications

For the most recent instrument specifications, search for the 3762 on the [Keithley Instruments website](http://www.tek.com/keithley) (<http://www.tek.com/keithley>).

Installation and connections

In this section:

Handling precautions	2-1
Unpack and inspect.....	2-1
Card connectors.....	2-2
Card installation	2-2

Handling precautions

Make sure to handle the 3762 carefully. Always grasp the multiplexer card by the side edges or covers. Do not touch board surfaces, components, or areas adjacent to electrical contacts. Contamination from foreign materials such as dirt, dust, and body oils can substantially lower leakage resistances, degrading card performance.

WARNING

The information in this section is intended only for qualified personnel. Do not perform these procedures unless you are qualified. Failure to recognize and observe standard safety precautions could result in personal injury or death due to electric shock.

Unpack and inspect

The 3762 was inspected both electrically and mechanically before shipment. Upon receiving the 3762, unpack all items from the shipping carton and check for any obvious damage that may have occurred during transit. Retain and use the original packaging materials in case reshipment is necessary.

To unpack and inspect your instrument:

1. Inspect the box for damage.
2. Open the top of the box.
3. Remove the contents (you should have received one 3762 card).
4. Inspect the 3762 card for any obvious signs of physical damage.
5. Report any damage to the shipping agent immediately.

Card connectors

All connections will need to be made before the card is installed in the mainframe. Because the card is rated at higher voltage than the mainframe, no backplane connectors are provided internal to the card. Ensure that any signals connected to the multimeter or mainframe are limited to the allowable ratings of the device. For more information about wire connections, see [Wire selection and preparation](#) (on page 3-2).

Figure 2: 3762 screw terminal connectors

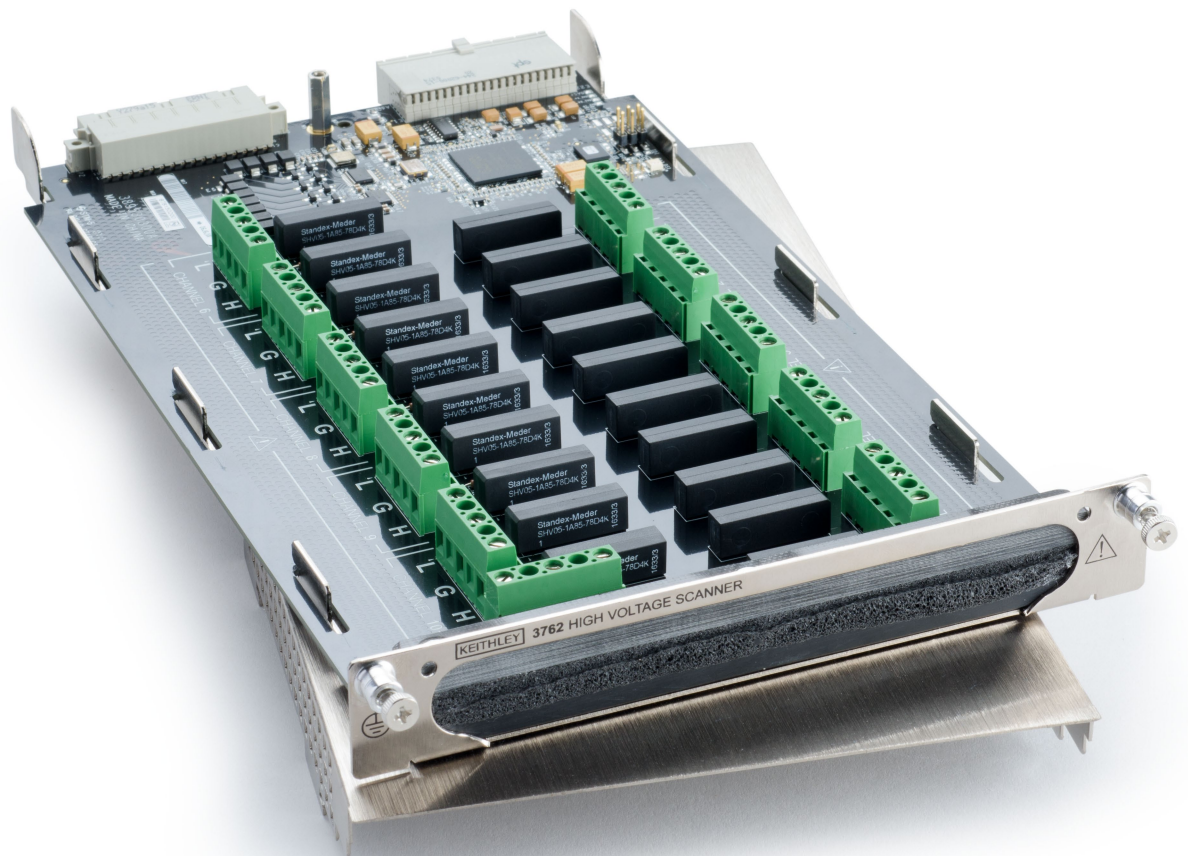

Card installation

WARNING

Slot covers must be installed on unused slots to prevent personal contact with high voltage circuits. Failure to recognize and observe standard safety precautions could result in personal injury or death due to electric shock.

Perform the following steps to install a switching card into the instrument mainframe:

1. Turn the instrument off and disconnect the power line cord and any other cables connected to the rear panel.
2. Position the instrument so that you are facing the rear panel.
3. Remove the slot cover plate from the desired mainframe slot. Retain the plate and screws for future use.
4. With the top cover of the switching card facing up, align the card's edge into the slot's card guide and slide in the card. For the last ¼ inch or so, press in firmly to mate the card connector to the mainframe connector.
5. On each side of the card, there is a mounting screw. Tighten these two screws to secure the card to the mainframe. Do not overtighten.
6. Reconnect the power line cable and any other cables to the rear panel, then turn the instrument on.
7. Press the **SLOT** key to see the model numbers, description, and the firmware revision of the installed switching cards, along with the mainframe firmware and DMM (if present).

NOTE

Item shipped may vary from model pictured here.

Figure 3: Typical module installation

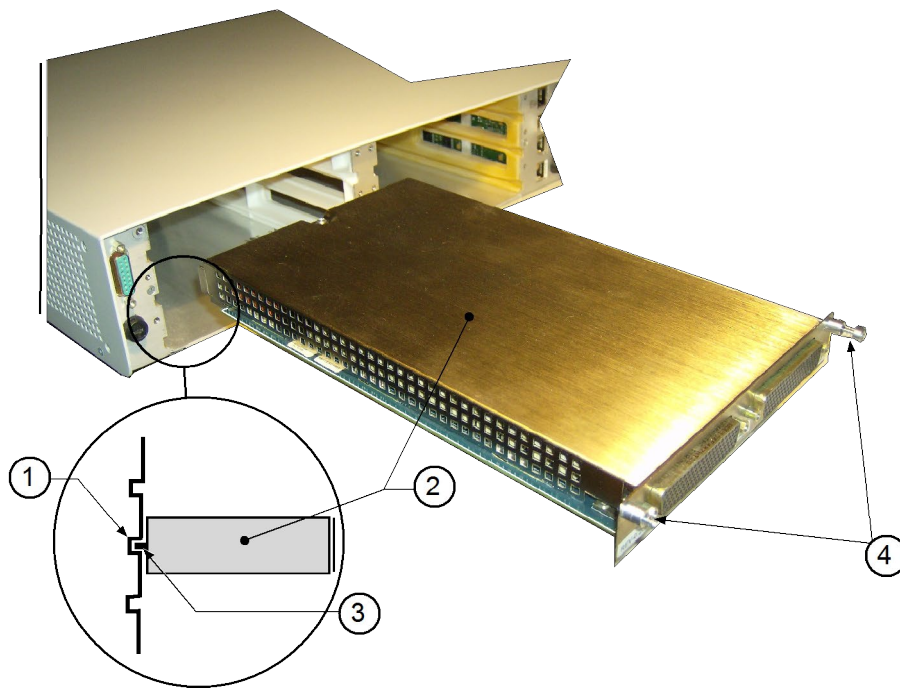

Item	Description
1	Card guide (part of mainframe)
2	Card
3	Card edge (part of card)
4	Mounting screw (part of card)

General operation

In this section:

General operation 3-1

General operation

This section provides information needed to use the 3762 10-channel 2 Form A High-Voltage Card with the Model 3706A system switch mainframe. Once the card is installed in the mainframe, refer to the *Series 3700A System Switch/Multimeter Reference Manual* for complete operating instructions.

Safety hazards

WARNING

To prevent electrical shock that could cause injury or death, never make or break connections while the equipment is powered on. User supplied lethal voltages may be present on the PC board or the connections. Turn off the equipment from the front panel, disconnect the main power cord, and discharge stored energy in external circuitry before making or breaking cable connections. Putting the mainframe equipment into an output-off state does not guarantee that the outputs are powered off if a hardware or software fault occurs. Precautions must be taken to prevent a shock hazard by surrounding the test device and any unprotected leads (wiring) with double insulation for 1000 volts, Category I.

Follow these recommendations before and after applying power to the equipment:

1. Do not exceed the 3762 maximum voltage as defined in the specifications.
2. Do not exceed the 3762 maximum common mode voltage of 1000 V as defined in the specifications. Exercise extreme caution when a shock hazard is present at the terminals. The American National Standard Institute (ANSI) states that a shock hazard exists when voltage levels greater than $30 V_{rms}$ or 42.4 V peak are present.
3. Make sure the system switch mainframe is grounded through an earth grounded receptacle before operation.
4. Turn off all power supplies and discharge any stored energy before installing or removing the 3762 from the system switch mainframe or the 3762 wires from the terminals.
5. Inspect all test lead connections for wear and defects such as cracks and exposed wires. Correct any defect found before operating the instrument.
6. Use appropriately rated cables when switching high voltages.
7. Ensure that the wire clamp at the rear of the card is securely installed.
8. Ensure that the mounting screws for the card are securely connected to the system switch mainframe chassis in order to provide the proper chassis protective grounding.
9. Read this manual carefully and adhere to all of the safety precautions listed before operating the instrument.

Wire selection and preparation

The internal wire conductor must be exposed (stripped) to the proper dimensions ensuring correct insertion depth in the screw terminal conductor. Excessive conductor length will expose electrical shock hazards to equipment and personnel. If the strip length is too short improper termination will result, due to the lack of electrical conductive surface area making contact with the screw terminal conductor.

NOTE

Strip wires to be inserted to six millimeters length, separate all wires by a minimum of one centimeter if connecting to High and Guard, or if connecting to High and Low, by a minimum of two centimeters. For example, the next figure is an example of the required distance between High and Low (2 cm).

Figure 4: Strip wire example

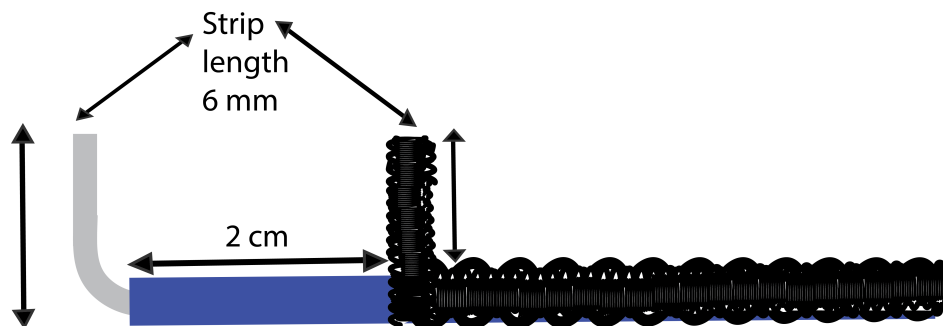

The wire must be inserted into the wire hole until the insulation is even with the housing at the wire hole opening. The screw must be hand tightened with the proper screwdriver to within 0.5 Newton meter (Nm) screw torque. Once tightened, pull back on the wire to make sure it is secure and make sure that there are no wire strands outside of the terminal block.

Wiring

NOTE

Because of the high impedance of the board, take special care when handling and using to prevent degradation of performance. Handle the board by the edges to avoid contaminating it with dirt or body oil.

Each channel on the 3762 consists of a double-pole, normally open (2 Form A) pair of single-pole switching relays. The 3762 will switch any one of the 10 signals (inputs) to one output, or switch one signal to any of one of 10 outputs.

⚠ WARNING

Hazardous voltages may be present on all input, output, and guard terminals. To prevent electric shock that could cause injury or death, never make or break connections to the 3762 while electrical equipment is powered on. Turn off the equipment from the front panel or disconnect the main power cord from the rear of the 3762 before handling cables. Turn off or disconnect any external equipment from the card before removing the card from the mainframe or changing any connections. Precautions must be taken to prevent a shock hazard by surrounding the test device and any unprotected leads (wiring) with double insulation for 1000 volts, Category I.

Wiring is accomplished by means of terminal strips as shown on the component layout (see [Wire selection and preparation](#) (on page 3-2)). Each channel has a HI connection, LO connection, and GUARD connection. Guard is common to all channels with the jumpers (R201-R210) installed. The 3762 is shipped with all jumpers installed.

1. Wiring is accomplished by means of terminal strips on screw terminals.
2. Resistance of the relay contacts (terminals) path is less than 0.2 Ω .
3. A common guard surrounds all analog signal paths.
4. Use wires or cables that are rated for maximum signal levels. The maximum allowable wire size is No. 16 AWG and the minimum size is No. 26 AWG.

NOTE

When operating at high current levels (amperes) consider the voltage burden ($I \times R$ drop) of the wire or cable that is used. For example, the approximate resistance of 24 gauge copper wire is 26 m Ω /ft. The voltage burden is approximately 26 mV/ft/amp. At the maximum signal current of 1 ampere the voltage burden would be 26 mV/ft. If the wire being used is 4 feet long, the voltage burden of the wire is approximately 0.1 V.

5. Route the wires through the rubber clamp pads located at the rear of the card.

Installation and removal

Once the card is wired, insert it card-edge first into the system switch mainframe by aligning it with the grooves in the appropriate slot. Make sure it is properly seated into the mainframe connector.

To remove a card, first turn off the mainframe and all other equipment connected to the card. Grasp the end of the card and carefully pull it out of the mainframe.

Operation considerations

In this section:

Cables.....	4-1
External factors	4-1
Reactive loads.....	4-2
Make a modification	4-3

Cables

Many electronic test systems use relay switching to connect multiple devices to sources and measurement instruments. In some cases, multiple sources and measuring instruments are connected to a single device. Switching allows automating the testing of multiple devices (for more information about switching, go to the [Keithley Instruments website](http://www.tek.com/keithley) (<http://www.tek.com/keithley>) and search for *Switching Handbook*).

WARNING

When switching signals greater than 30 V RMS or 42.4 V peak take care to prevent contact with live circuits which could cause electrical shock resulting in injury or death.

Shielded cables should be used with the 3762 high current card when switching above 50 V or high current. The shield should be connected to circuit guard. This helps prevent excessive radiation from the cables from interfering with any equipment. The cable rating must not exceed the maximum allowable signal levels as defined in the specifications.

External factors

The 3762 is specified for a resistive load, however, external circuit capacitances and inductances can cause excessive currents and voltages across the relay contacts. The currents and voltages must be limited to within the maximum allowable signal levels.

- **Capacitance** - Charged capacitances in the circuit can cause excessive currents (surge currents) to flow through the relay contacts if the source is shorted out or the output is switched to capacitive loads. This excessive current can weld the relay contacts together. Therefore, use series resistors, where needed, to limit the maximum current that can flow to within contact ratings. The maximum signal levels are stated in the specifications.
- **Inductance** - The inductance of cables can produce high voltage and arcing across relay contacts when switching. The peak transients must be limited to within the maximum signal levels as defined in the specifications.

Reactive loads

The 3762 is specified for resistive loads only. Since reactive loads can cause excessive currents and voltages, current surge limiting (for capacitive loads) and voltage clamping (for inductive loads) are required to prevent damaging the relays and external circuitry.

Capacitive loads

The surge current from a capacitive load must be less than 0.5 A to protect the relays. The next figure shows typical circuits to limit current surges. Also, consider the maximum load of 10 VA when determining the current limit. For example, when switching 500 V, the current must be limited to 20 mA ($A = 10 \text{ VA}/500 \text{ V}$) and the limiting resistor calculation of the next figure would be:

$$R = V/I = 500 \text{ V}/20 \text{ mA} = 25 \text{ k}\Omega$$

NOTE

Use an appropriately rated resistor in the test.

Figure 5: Model 3762 Limiting capacitive reaction (resistor limited)

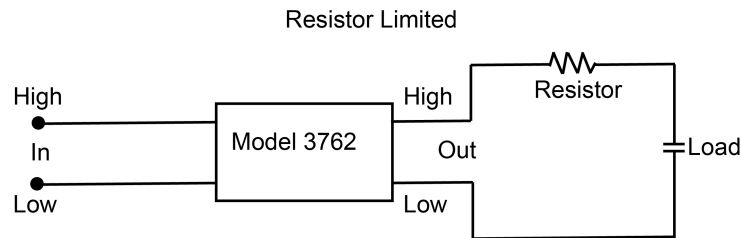

NOTE

The Thermistor must have high resistance when cold, low resistance when hot, and have fast thermal recovery.

Figure 6: Model 3762 Limiting capacitive reaction current (thermistor limited)

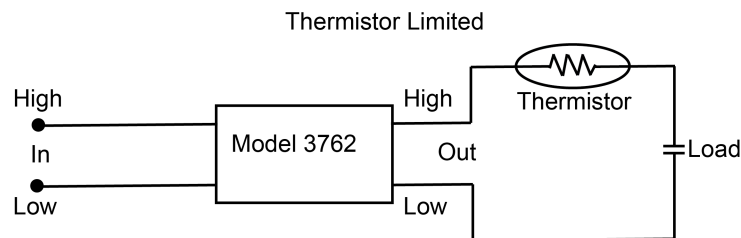

Inductive loads

Inductive reaction voltage, $L(di/dt)$, must be less than 1000 V. Typical clamping circuits are shown in the next figures. Also, consider the maximum load of 10 VA when determining the voltage limit. For example, when switching 40 mA, the voltage must be limited to 250 V ($V = 10 \text{ VA}/40 \text{ mA}$) and the clamping resistor calculation in the next figure would be:

$$R = V/I = 250 \text{ V}/40 \text{ mA} = 6.25 \text{ k}\Omega$$

Figure 7: Model 3762 Limiting inductive reaction voltage

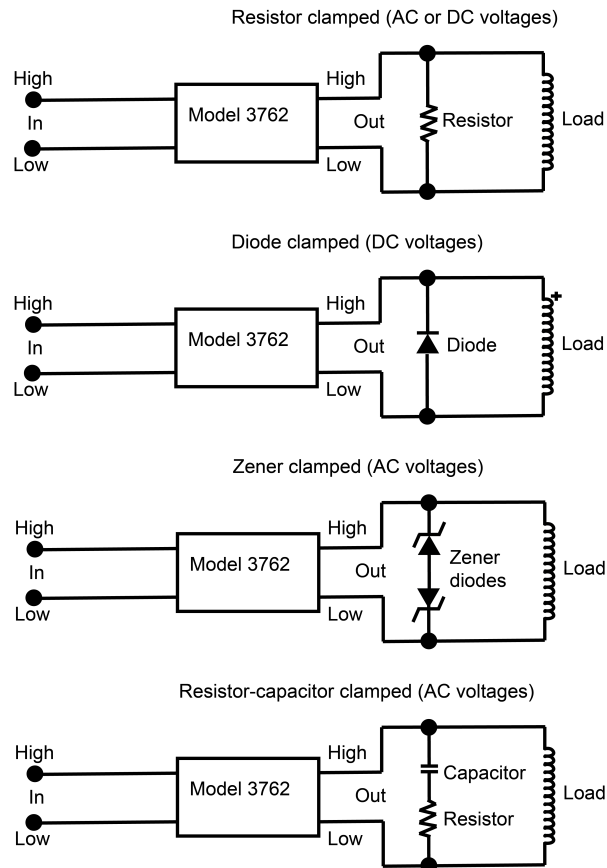

Make a modification

The guard for channels on the 3762 high voltage multiplexer card are all connected to a common guard path. If isolation of the guard is required between a channel to any other channel or the output, the 3762 can be modified to disconnect the guard. The modification involves removing a jumper for the channel that is to be modified. For example, remove jumper R201 to disconnect channel one's guard terminal from all other channel output guard terminals.

It is recommended to remove the jumpers by cutting them with a pair of wire cutters.

Typical applications

In this section:

Model 3762 typical applications 5-1

Model 3762 typical applications

The 3762 can monitor high voltages from 10 different devices under test (DUT), switch a high-voltage source to 10 separate DUTs, or connect multiple DUTs to multiple sources. For more information about some typical applications and graphics showing typical configurations, refer to the Keithley Instruments *Switching Handbook*. In some cases, multiple sources and measuring instruments are connected to a single device. Switching allows automating the testing of multiple devices (for more information about switching, go to the [Keithley Instruments website](http://www.tek.com/keithley) (<http://www.tek.com/keithley>) and search for *Switching Handbook*).

Shielded application

CAUTION

This application is one channel at a time. Due to the possibility of high voltage, be sure to break one connection before connecting another or the card could be damaged.

The measurement scheme shown in the next figure is used to make a shielded floating measurement on up to 10 DUTs with one multimeter. The guard traces are used as shield, so they are connected to the multimeter's LO. If both GUARD pins cannot be kept at the same potential, remove the jumper.

Figure 8: 3762 Shielded floating measurement

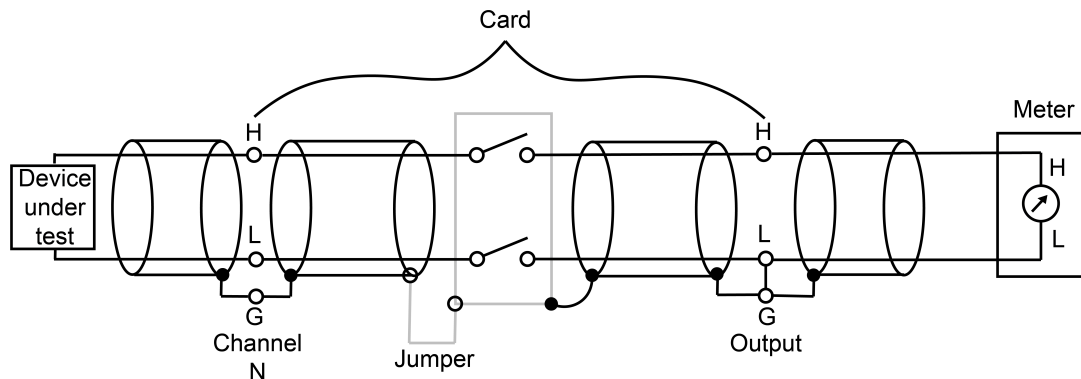

Guarded application

Non-driven guarded measurements are made with the set up shown in the next figure. The jumper is installed to provide a guard that completely encloses HI and LO. This guards HI and LO from other channels on the card for improved channel isolation.

Figure 9: Guarded floating measurement

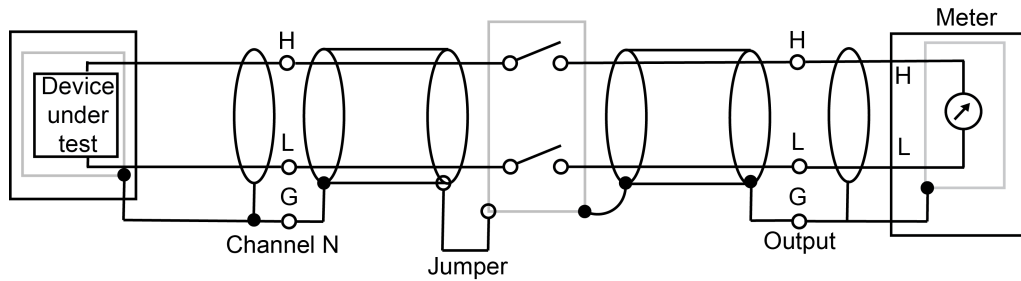

Driven guard application

If multiple sources are switched to a DUT using a driven guard, as shown in the next figure, the guard must be switched. The jumper for each channel in use is removed so that the various sources will not try to drive the guards. Instrument LO is not switched or is switched by another card in the next two figure.

Figure 10: 3762 Single pole switch with switched guard

Figure A: Channel N - Guard driven by sources; no jumper.

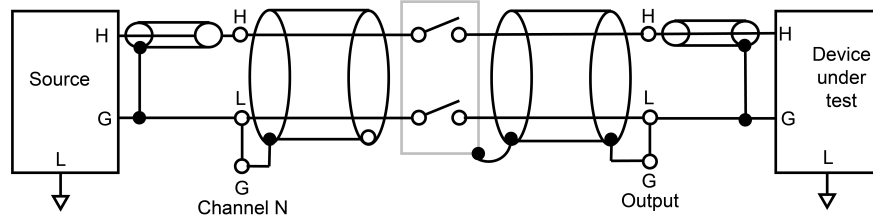
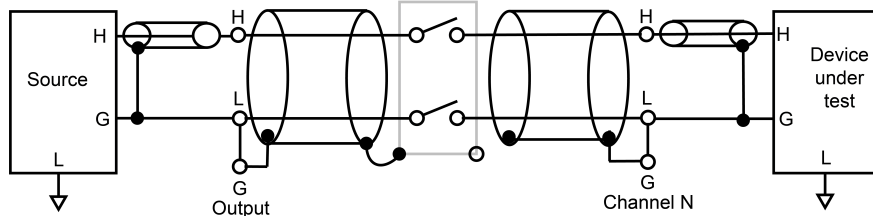

Figure B: Channel N - Guard driven by source; no jumper.



Note that the previous figure labeled B is the same configuration for connecting one source to multiple DUTs. In this case, the jumper is removed to reduce the capacitive loading on the guard.

LO and GUARD are shorted at both ends of the signal path to allow for the switched guard. LO for the sources and the DUT must have an external connection.

Four-wire application

Connecting multiple DUTs to one instrument using either a Kelvin technique or external sense as with a Source Measure Unit (SMU), requires two cards operating in four-pole mode. This is shown in the next figure.

NOTE

The Guard and Shield are connected to the card end only and not to the device under test. Also, on the source-measure instrument, the Guard connection is not always made. It may not be required at high current levels, such as when circuit leakage is lower than high current accuracy requirements.

Figure 11: 3762 Source with external sense or Kelvin Measurement

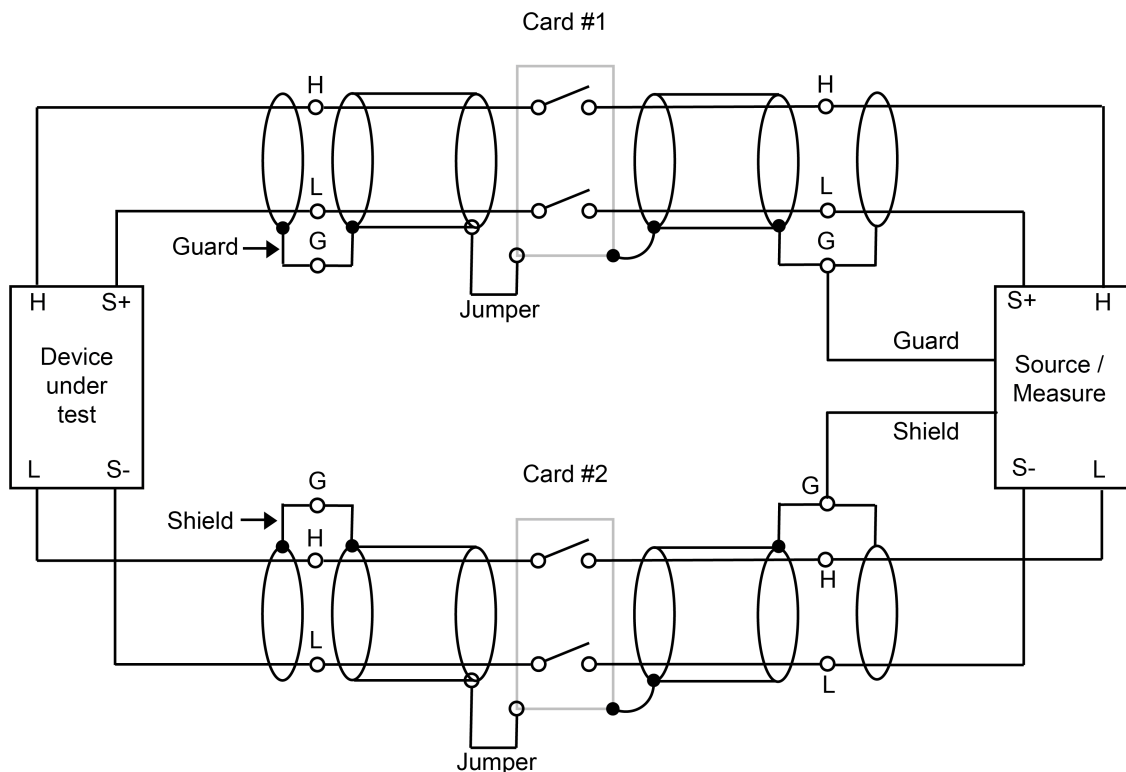

HI and Sense HI (S+) are switched through one card. The jumper is installed to provide a guard all the way to the DUT. Since this is a driven guard, it is connected only to the guard of the instrument and not terminated at the DUT.

LO and Sense LO (S-) are switched through the second card. The jumper is installed to provide shielding for these lines. The shield on the cabling is installed to provide shielding for these lines. The shield on the cabling should cover as much of the signal lines as possible, and should be terminated only at the instrument. Shields are typically at circuit low or earth ground.

This configuration combines sense and Kelvin configurations so that guard on the card is driven for the High leads and provides a shield for the Low leads.

Switch terminology

In this section:

Switch terminology 6-1

Switch terminology

The terms Form A, B, or C are used in switch terminology, throughout this manual, and are described as follows:

- Form A is simply a single-pole normally-open (SPNO) switch (see next figure) A double-pole switch normally-open is classified as a 2 Form A.
- Form B is similar to Form A except that its contacts are normally-closed (see next figure). A double-pole switch normally-closed is classified as a 2 Form B.
- Form C (see next figure) is a single-pole double-throw switch. It could also be a multiple switch such as a double-pole which would be classified as a 2 Form C.

Figure 12: Switch terminology

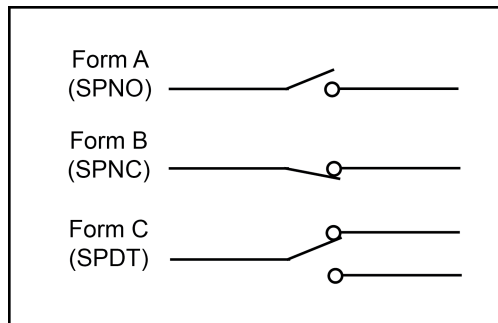

Index

C

Cables • 4-1
Capacitive loads • 4-2
Card connectors • 2-2
Card installation • 2-2
Contact information • 1-2

D

Driven guard application • 5-2

E

Extended warranty • 1-2
External factors • 4-1

F

Four-wire application • 5-3

G

General information • 1-2
General operation • 3-1
Guarded application • 5-2

H

Handling precautions • 2-1

I

Inductive loads • 4-3
Installation and connections • 2-1
Installation and removal • 3-3
Introduction • 1-1

M

Make a modification • 4-3
Model 3762 typical applications • 5-1
modules
 installation • 2-2

O

Operation considerations • 4-1

R

Reactive loads • 4-2

S

Safety hazards • 3-1
Series 3700A documentation • 1-2
Shielded application • 5-1
Specifications • 1-3
Switch terminology • 6-1
System switch / multimeter card compatibility • 1-1

T

Typical applications • 5-1

U

Unpack and inspect • 2-1

W

Wire selection and preparation • 2-2, 3-2, 3-3
Wiring • 3-3

Y

Your multiplexer card • 1-1

Specifications are subject to change without notice.
All Keithley trademarks and trade names are the property of Keithley Instruments.
All other trademarks and trade names are the property of their respective companies.

Keithley Instruments
Corporate Headquarters • 28775 Aurora Road • Cleveland, Ohio 44139 • 440-248-0400 • Fax: 440-248-6168 • 1-800-935-5595 • www.tek.com/keithley

