

Model 4200A-CVIV Multi-Switch

User's Manual

4200A-CVIV-900-01 Rev. B / November 2017



4200A-CVIV-900-01 B

Model 4200A-CVIV

Multi-Switch

User's Manual

© 2017, Keithley Instruments

Cleveland, Ohio, U.S.A.

All rights reserved.

Any unauthorized reproduction, photocopy, or use of the information herein, in whole or in part, without the prior written approval of Keithley Instruments is strictly prohibited.

All Keithley Instruments product names are trademarks or registered trademarks of Keithley Instruments. Other brand names are trademarks or registered trademarks of their respective holders.

Actuate®

Copyright © 1993-2003 Actuate Corporation.

All Rights Reserved.

Microsoft, Visual C++, Excel, and Windows are either registered trademarks or trademarks of Microsoft Corporation in the United States and/or other countries.

Document number: 4200A-CVIV-900-01 Rev. B / November 2017

The following safety precautions should be observed before using this product and any associated instrumentation. Although some instruments and accessories would normally be used with nonhazardous voltages, there are situations where hazardous conditions may be present.

This product is intended for use by personnel who recognize shock hazards and are familiar with the safety precautions required to avoid possible injury. Read and follow all installation, operation, and maintenance information carefully before using the product. Refer to the user documentation for complete product specifications.

If the product is used in a manner not specified, the protection provided by the product warranty may be impaired.

The types of product users are:

Responsible body is the individual or group responsible for the use and maintenance of equipment, for ensuring that the equipment is operated within its specifications and operating limits, and for ensuring that operators are adequately trained.

Operators use the product for its intended function. They must be trained in electrical safety procedures and proper use of the instrument. They must be protected from electric shock and contact with hazardous live circuits.

Maintenance personnel perform routine procedures on the product to keep it operating properly, for example, setting the line voltage or replacing consumable materials. Maintenance procedures are described in the user documentation. The procedures explicitly state if the operator may perform them. Otherwise, they should be performed only by service personnel.

Service personnel are trained to work on live circuits, perform safe installations, and repair products. Only properly trained service personnel may perform installation and service procedures.

Keithley Instruments products are designed for use with electrical signals that are measurement, control, and data I/O connections, with low transient overvoltages, and must not be directly connected to mains voltage or to voltage sources with high transient overvoltages. Measurement Category II (as referenced in IEC 60664) connections require protection for high transient overvoltages often associated with local AC mains connections. Certain Keithley Instruments measuring instruments may be connected to mains. These instruments will be marked as category II or higher.

Unless explicitly allowed in the specifications, operating manual, and instrument labels, do not connect any instrument to mains.

Exercise extreme caution when a shock hazard is present. Lethal voltage may be present on cable connector jacks or test fixtures. The American National Standards Institute (ANSI) states that a shock hazard exists when voltage levels greater than 30 V RMS, 42.4 V peak, or 60 VDC are present. A good safety practice is to expect that hazardous voltage is present in any unknown circuit before measuring.

Operators of this product must be protected from electric shock at all times. The responsible body must ensure that operators are prevented access and/or insulated from every connection point. In some cases, connections must be exposed to potential human contact. Product operators in these circumstances must be trained to protect themselves from the risk of electric shock. If the circuit is capable of operating at or above 1000 V, no conductive part of the circuit may be exposed.

Do not connect switching cards directly to unlimited power circuits. They are intended to be used with impedance-limited sources. NEVER connect switching cards directly to AC mains. When connecting sources to switching cards, install protective devices to limit fault current and voltage to the card.

Before operating an instrument, ensure that the line cord is connected to a properly-grounded power receptacle. Inspect the connecting cables, test leads, and jumpers for possible wear, cracks, or breaks before each use.

When installing equipment where access to the main power cord is restricted, such as rack mounting, a separate main input power disconnect device must be provided in close proximity to the equipment and within easy reach of the operator.

For maximum safety, do not touch the product, test cables, or any other instruments while power is applied to the circuit under test. ALWAYS remove power from the entire test system and discharge any capacitors before: connecting or disconnecting cables or jumpers, installing or removing switching cards, or making internal changes, such as installing or removing jumpers.

Do not touch any object that could provide a current path to the common side of the circuit under test or power line (earth) ground. Always make measurements with dry hands while standing on a dry, insulated surface capable of withstanding the voltage being measured.

For safety, instruments and accessories must be used in accordance with the operating instructions. If the instruments or accessories are used in a manner not specified in the operating instructions, the protection provided by the equipment may be impaired.

Do not exceed the maximum signal levels of the instruments and accessories. Maximum signal levels are defined in the specifications and operating information and shown on the instrument panels, test fixture panels, and switching cards.

When fuses are used in a product, replace with the same type and rating for continued protection against fire hazard.

Chassis connections must only be used as shield connections for measuring circuits, NOT as protective earth (safety ground) connections.

If you are using a test fixture, keep the lid closed while power is applied to the device under test. Safe operation requires the use of a lid interlock.

If a  screw is present, connect it to protective earth (safety ground) using the wire recommended in the user documentation.

The  symbol on an instrument means caution, risk of hazard. The user must refer to the operating instructions located in the user documentation in all cases where the symbol is marked on the instrument.

The  symbol on an instrument means warning, risk of electric shock. Use standard safety precautions to avoid personal contact with these voltages.

The  symbol on an instrument shows that the surface may be hot. Avoid personal contact to prevent burns.

The  symbol indicates a connection terminal to the equipment frame.

If this  symbol is on a product, it indicates that mercury is present in the display lamp. Please note that the lamp must be properly disposed of according to federal, state, and local laws.

The **WARNING** heading in the user documentation explains hazards that might result in personal injury or death. Always read the associated information very carefully before performing the indicated procedure.

The **CAUTION** heading in the user documentation explains hazards that could damage the instrument. Such damage may invalidate the warranty.

The **CAUTION** heading with the  symbol in the user documentation explains hazards that could result in moderate or minor injury or damage the instrument. Always read the associated information very carefully before performing the indicated procedure. Damage to the instrument may invalidate the warranty.

Instrumentation and accessories shall not be connected to humans.

Before performing any maintenance, disconnect the line cord and all test cables.

To maintain protection from electric shock and fire, replacement components in mains circuits — including the power transformer, test leads, and input jacks — must be purchased from Keithley Instruments. Standard fuses with applicable national safety approvals may be used if the rating and type are the same. The detachable mains power cord provided with the instrument may only be replaced with a similarly rated power cord. Other components that are not safety-related may be purchased from other suppliers as long as they are equivalent to the original component (note that selected parts should be purchased only through Keithley Instruments to maintain accuracy and functionality of the product). If you are unsure about the applicability of a replacement component, call a Keithley Instruments office for information.

Unless otherwise noted in product-specific literature, Keithley Instruments instruments are designed to operate indoors only, in the following environment: Altitude at or below 2,000 m (6,562 ft); temperature 0 °C to 50 °C (32 °F to 122 °F); and pollution degree 1 or 2.

To clean an instrument, use a cloth dampened with deionized water or mild, water-based cleaner. Clean the exterior of the instrument only. Do not apply cleaner directly to the instrument or allow liquids to enter or spill on the instrument. Products that consist of a circuit board with no case or chassis (e.g., a data acquisition board for installation into a computer) should never require cleaning if handled according to instructions. If the board becomes contaminated and operation is affected, the board should be returned to the factory for proper cleaning/servicing.

Safety precaution revision as of June 2017.

Table of contents

- Introduction..... 1-1**
 - Introduction 1-1
 - Extended warranty 1-2
 - Contact information 1-2
 - General ratings..... 1-2
 - Specifications 1-2
 - Unpack and inspect the instrument..... 1-3
 - Hardware and software requirements 1-3

- Getting started 2-1**
 - Introduction 2-1
 - DUT connections panel summary..... 2-1
 - DUT channel connections 2-2
 - Ground connections 2-2
 - Inputs panel summary..... 2-3
 - Connections 2-4
 - Display summary..... 2-5

- Install and configure the 4200A-CVIV 3-1**
 - Introduction 3-1
 - Mechanical dimensions..... 3-1
 - Location considerations 3-2
 - Connect to protective earth..... 3-3
 - Install and remove preamplifier and pass-thru modules 3-4
 - Install and remove channel blockers..... 3-7
 - Mount the 4200A-CVIV Model 4200A-CVIV 3-9
 - Configure the 4200A-CVIV with KCon 3-10

- Switching and software configuration 4-1**
 - Introduction 4-1
 - 4200A-CVIV switching 4-2
 - Open 4-3
 - SMU switching 4-4
 - CV HI switching..... 4-5
 - CV LO switching..... 4-5
 - CV Guard switching 4-6
 - Ground unit switching..... 4-7
 - AC coupled AC ground configuration 4-8
 - Bias tee switching 4-9
 - Bias tee SMU AC ground 4-10

Automate switching between 2-wire and 4-wire mode	4-11
Measurement compensation	4-12
CVU compensation	4-13
Model 4200A-CVIV compensation connections	4-14
Control the Model 4200A-CVIV with Clarius	4-16
cviv-configure	4-17
cvu-cviv-comp-collect	4-21
Enable compensation for a test	4-25
Control the 4200A-CVIV with LPT commands	4-26
cviv_config	4-27
cviv_display_config	4-28
cviv_display_power	4-29
Typical applications	5-1
Introduction	5-1
I-V characterization on a 2-terminal device	5-1
C-V characterization on a 2-terminal device	5-3
I-V characterization on a 3-terminal device	5-5
C-V characterization on a 3-terminal device	5-7
I-V characterization on a 4-terminal device	5-9
C-V characterization on a 4-terminal device	5-11
Maintenance	6-1
Introduction	6-1
Cleaning the display	6-1
Upgrade the instrument firmware	6-2

Introduction

In this section:

Introduction	1-1
Extended warranty	1-2
Contact information	1-2
General ratings.....	1-2
Specifications	1-2
Unpack and inspect the instrument.....	1-3
Hardware and software requirements	1-3

Introduction

The Keithley Instruments Model 4200A-CVIV Multi-Switch is a multiplexed switching accessory for the 4200A-SCS that allows you to switch between I-V and C-V measurements with no changes to cables or connections to the device under test (DUT). You can also perform I-V testing with up to four SMUs (4200-SMU or 4210-SMU) and switch the outputs of the 4210-CVU to any of the four output terminals. This accessory creates a faster and more efficient device testing workflow for any application that requires I-V and C-V measurements on the same device.

Figure 1: Keithley Instruments Model 4200A-CVIV Multi-Switch



The built-in display provides clear, real-time test information near the DUT. You can personalize the output naming convention with the Clarius software, rotate to match your testing environment, and turn off the display to reduce light near the DUT.

Extended warranty

Additional years of warranty coverage are available on many products. These valuable contracts protect you from unbudgeted service expenses and provide additional years of protection at a fraction of the price of a repair. Extended warranties are available on new and existing products. Contact your local Keithley Instruments office, sales partner, or distributor for details.

Contact information

If you have any questions after you review the information in this documentation, please contact your local Keithley Instruments office, sales partner, or distributor. You can also call the corporate headquarters of Keithley Instruments (toll-free inside the U.S. and Canada only) at 1-800-935-5595, or from outside the U.S. at +1-440-248-0400. For worldwide contact numbers, visit tek.com/keithley (tek.com/keithley).

General ratings

The 4200A-CVIV instrument's general ratings and connections are listed in the following table.

Category	Specification
Voltage rating	210 V
Current rating	1 A
Input and output connections	See DUT connections panel summary (on page 2-1) and Inputs panel summary (on page 2-3)
Environmental conditions	<p>For indoor use only</p> <p>Temperature range: Operating: 10 °C to 40 °C (50 °F to 104 °F) Storage: – 15 °C to 60 °C (5 °F to 140 °F)</p> <p>Humidity range: Operating: 5 % to 80 % relative humidity, non-condensing Storage: 5 % to 90 % relative humidity, non-condensing</p> <p>Altitude: Operating: 0 to 2000 m (0 to 6252 ft) Storage: 0 to 4600 m (0 to 15092 ft)</p> <p>Pollution degree: 1 or 2</p>

Specifications

For instrument specifications, search for the 4200A-SCS Parameter Analyzer Datasheet on the Keithley Instruments website (tek.com/keithley).

Unpack and inspect the instrument

To unpack and inspect the instrument:

1. Inspect the box for damage.
2. Open the top of the box.
3. Remove the accessories and verify that all items are included. You should have received:
 - Two 4200A-CVIV-SPT SMU Pass-Thru modules
 - Two channel blockers
 - Two safety ground cables
 - One USB cable
4. Remove the packaging insert.
5. Remove the 4200A-CVIV from the box.

CAUTION

Do not use the front bezel to lift the 4200A-CVIV. Using the front bezel can cause damage to the instrument.

6. Inspect the instrument for any obvious signs of physical damage.
7. Report any damage to the shipping agent immediately.

Hardware and software requirements

The following are required to use the 4200A-CVIV.

- Keithley Instruments 4200A-SCS Parameter Analyzer running the latest software release
- One (for 2-wire measurements) or two (for 4-wire measurements) 4200-TRX-0.75 or CA-534-24A triaxial cables (per channel)
- One 4210-CVU
- Up to four SMUs 4200-SMU or 4210-SMUs each, with either 4200-PA Remote Preamplifiers or 4200A-CVIV-SPT SMU Pass-Thru Modules

NOTE

For each SMU connected to the 4200A-CVIV, you must also install at least one 4200-PA or 4200A-CVIV-SPT Pass-Thru module.

Getting started

In this section:

Introduction	2-1
DUT connections panel summary	2-1
Inputs panel summary	2-3
Display summary	2-5

Introduction

This section provides an overview of the 4200A-CVIV display and connectors.

DUT connections panel summary

Device connections are made to the device under test (DUT) instrument panel of the 4200A-CVIV.

The DUT panel of the 4200A-CVIV is shown below. Descriptions of the connections are provided after the figure.

Figure 2: 4200A-CVIV DUT panel

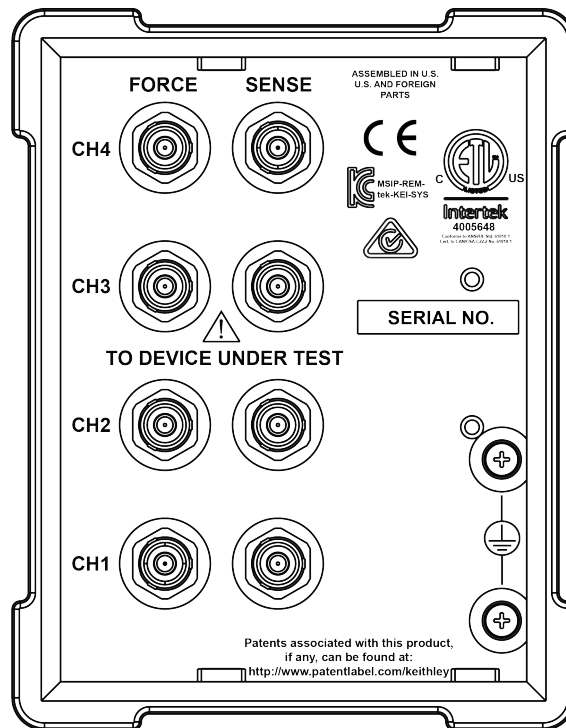

DUT channel connections

DUT channel connections

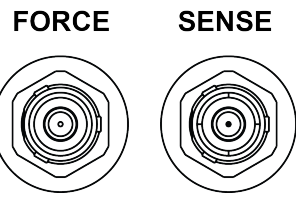

Triaxial force and sense connectors are provided on channels 1 through 4 for connection to a DUT.

Ground connections

Ground connections

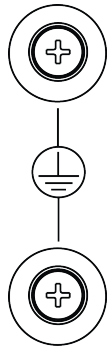

Two ground screws are provided for connections to protective earth (safety ground).

Inputs panel summary

Instruments are connected to the inputs panel of the 4200A-CVIV.

The inputs panel of the 4200A-CVIV is shown below. No preamplifier or pass-through modules are installed in this figure. Descriptions of the connections are provided after the figure.

NOTE

GNDU SENSE is available with 4200A-CVIV hardware versions 2.0 or newer.

⚠ WARNING

Each SMU input that is not in use must have its access restricted by an included channel blocker. Refer to the [Installing and removing channel blockers](#) (on page 3-7) topic for more information.

Figure 3: 4200A-CVIV inputs panel (SMU inputs empty)

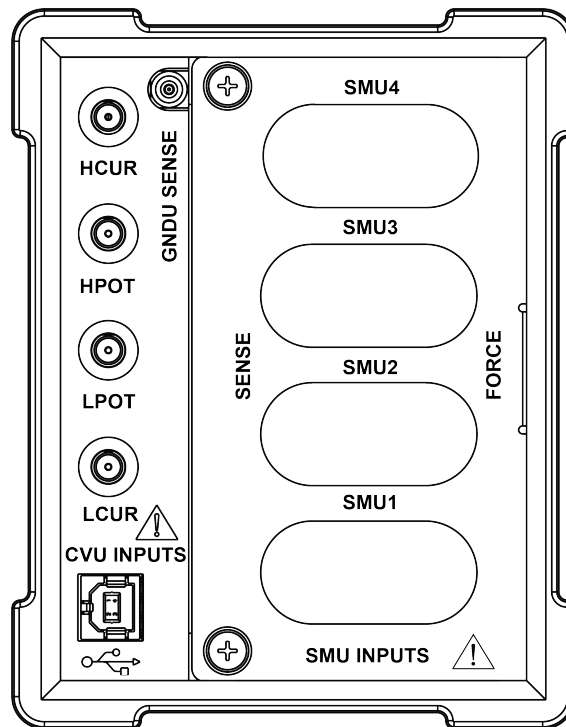

Connections

HCUR CVU input



HCUR

The HCUR (force HI) CVU input is a female SMA connector that you use to connect to the 4210-CVU.

HPOT CVU input



HPOT

The HPOT (sense HI) CVU input is a female SMA connector that you use to connect to the 4210-CVU.

LPOT CVU input



LPOT

The LPOT (sense LO) CVU input is a female SMA connector that you use to connect to the 4210-CVU.

LCUR CVU input



LCUR

The LCUR (force LO) CVU input is a female SMA connector that you use to connect to the 4210-CVU.

GNDU SENSE input



The GNDU SENSE input is a female miniature triaxial connector that you use to connect to the triaxial SENSE connector of the ground unit on the 4200A-SCS. This input is only available with 4200A-CVIV hardware versions 2.0 and newer.

SMU inputs (4200A-CVIV-SPT SMU Pass-Thru installed)

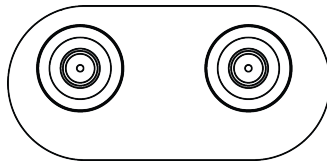

The 4200A-CVIV-SPT SMU Pass-Thru module can be installed in any bay of the 4200A-CVIV. The triaxial connectors provide a direct interface with your SMU.

SMU inputs (4200-PA Remote Preamp installed)

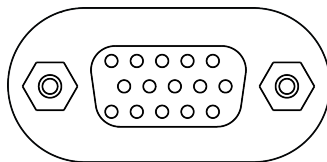

The 4200-PA Remote Preamp can be installed in any bay of the 4200A-CVIV. The preamplifier's serial interface provides a connection with the 42x0-SMU installed in the 4200A-SCS.

USB input

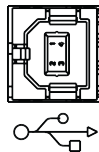

A USB-B port is provided to connect to your 4200A-SCS. The port provides both data and power to the 4200A-CVIV.

Display summary

Figure 4: 4200A-CVIV front display panel

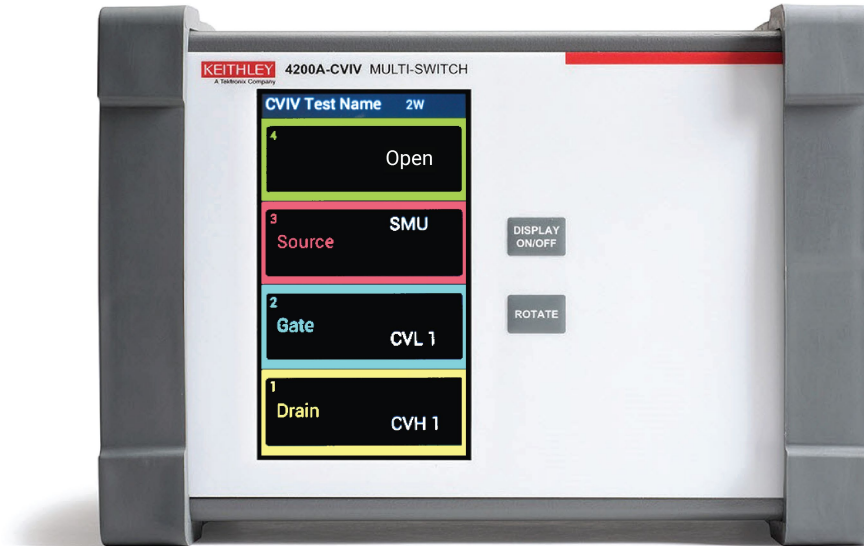

The 4200A-CVIV features a full-color LCD display that illustrates the name of your test, the name of the device under test (DUT), the instrument configuration for each channel, and a 2-wire or 4-wire indicator.

You can turn the display on or off with the DISPLAY ON/OFF button. Press the ROTATE button to orient the display for your test station configuration.

When you reset the 4200A-CVIV, the instrument returns to the default Open state. Any terminal setting names are removed (see the next figure) and replaced with "Open."

Figure 5: Default state display of the 4200A-CVIV

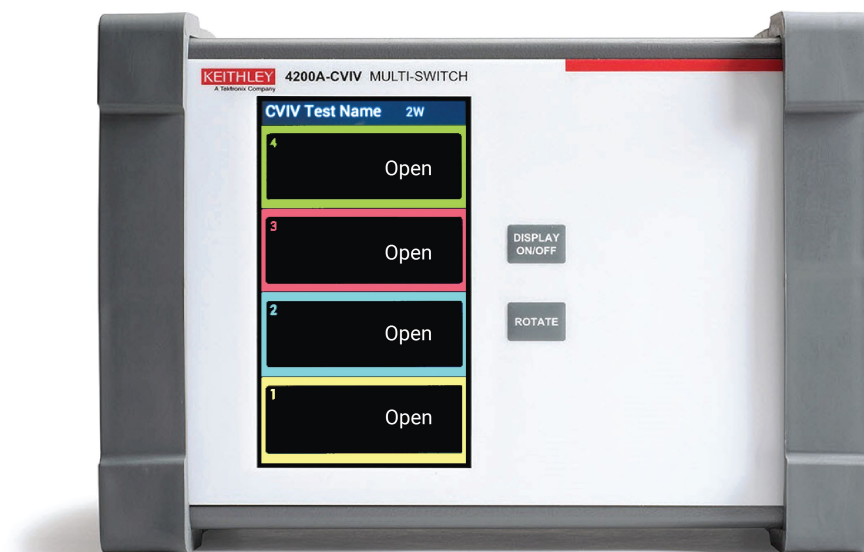

Install and configure the 4200A-CVIV

In this section:

Introduction	3-1
Mechanical dimensions	3-1
Location considerations	3-2
Connect to protective earth	3-3
Install and remove preamplifier and pass-thru modules	3-4
Install and remove channel blockers	3-7
Mount the 4200A-CVIV Model 4200A-CVIV	3-9
Configure the 4200A-CVIV with KCon	3-10

Introduction

The 4200A-CVIV can be quickly installed and configured for a variety of testing scenarios. This section contains information on locating and mounting the instrument, safety grounding, using the instrument with preamplifier modules, and configuration of the instrument using the Keithley Instruments Configuration Utility (KCon).

Mechanical dimensions

Figure 6: 4200A-CVIV mechanical dimensions, bumpers installed

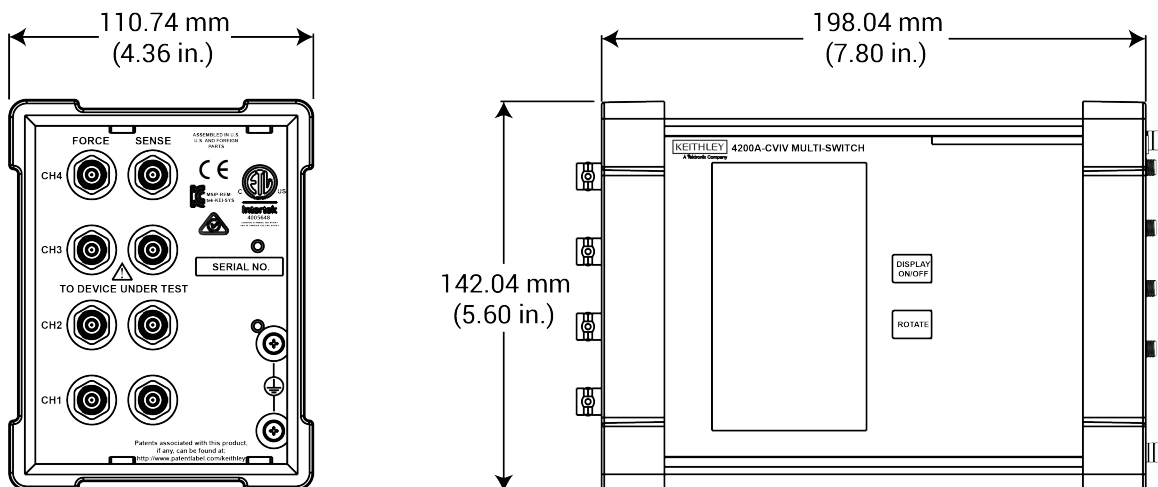
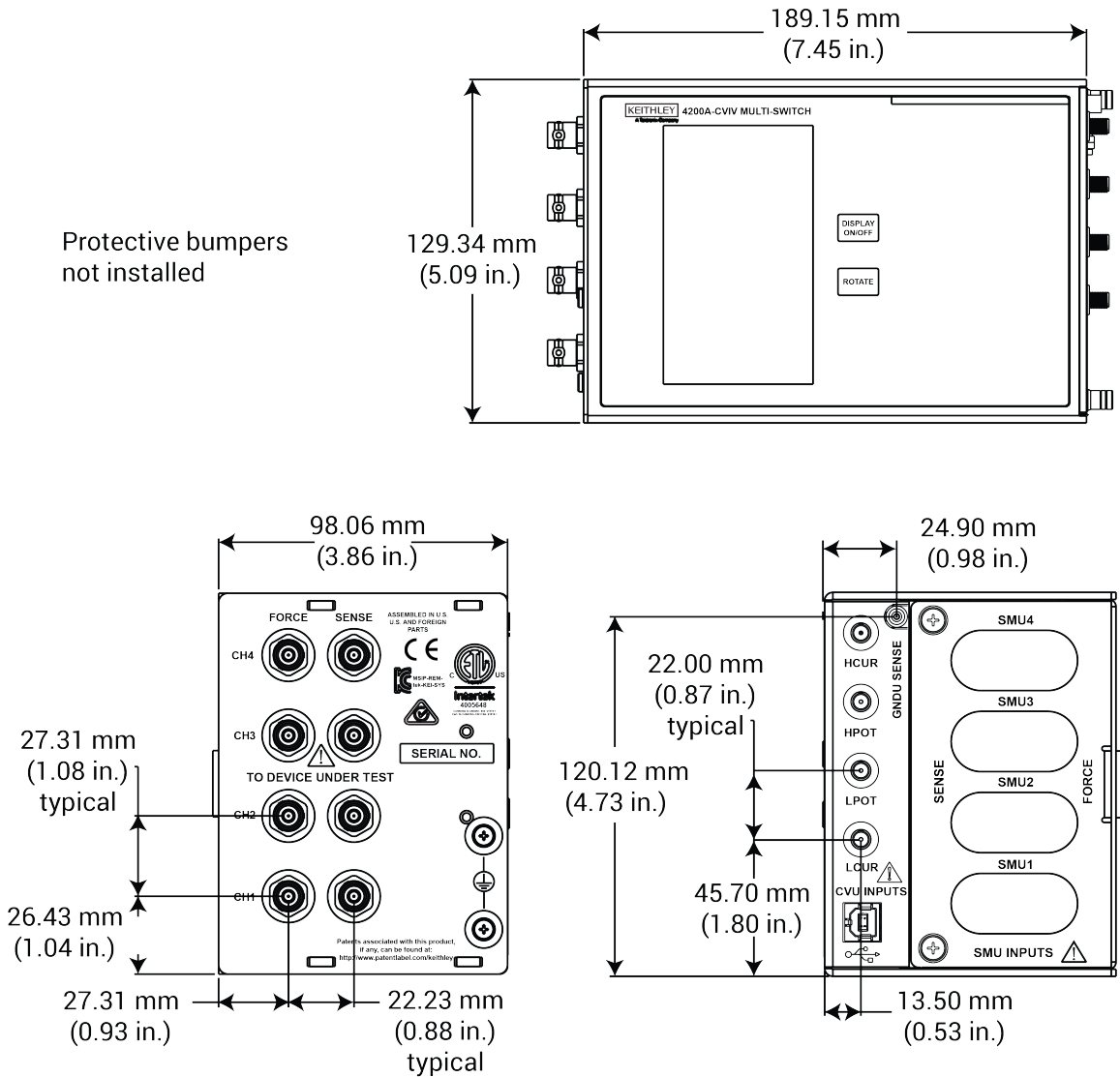

Figure 7: 4200A-CVIV mechanical dimensions, bumpers not installed



Location considerations

The 4200A-CVIV is designed to be located as close as possible to a probe station to ensure accurate measurements.

Connect to protective earth

WARNING

The 4200A-CVIV must be connected to protective earth (safety ground) using both of the supplied green-yellow ground cables. The ground wires must be attached to both ground screws on the 4200A-CVIV before powering on the unit, and they must be connected independently to earth ground (do not connect both ground wires to the same earth safety ground). Failure to attach the ground wires independently to a known protective earth may result in personal injury or electric shock.

1. Connect both of the supplied grounding cables to the two grounding terminals of the 4200A-CVIV.

Figure 8: Connecting ground cables to the 4200A-CVIV

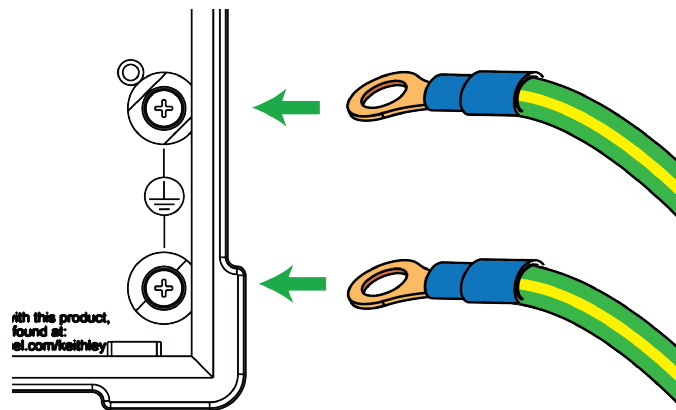

2. Connect the ends of the grounding cables to the two independent protective earth (safety ground) terminals.

Install and remove preamplifier and pass-thru modules

You can install up to four Keithley Instruments 4200-PA Remote Preamplifiers or 4200-CVIV-SPT SMU Pass-Thru modules (see the following figure) in the 4200A-CVIV in any combination.

Figure 9: 4200-PA Remote PreAMP and 4200A-CVIV-SPT SMU Pass-Thru modules

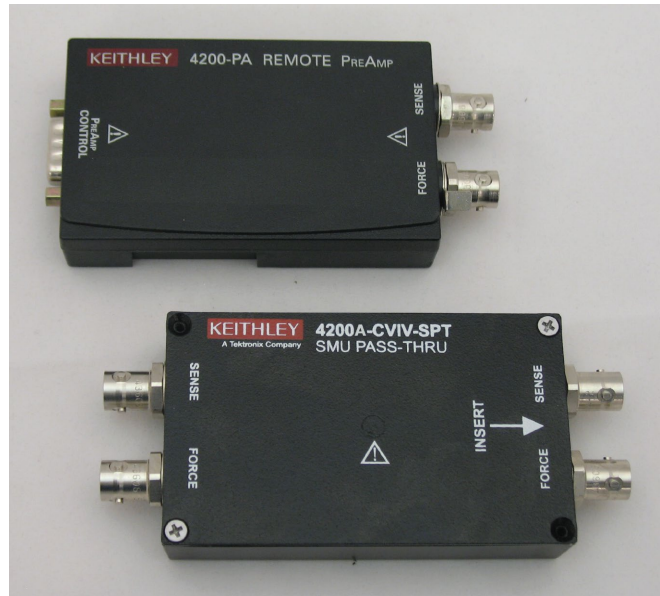

Make sure that the preamplifier and pass-through modules are properly aligned when they are inserted into the SMU input slots of the 4200A-CVIV. Additionally, be sure to install a channel blocker in each slot that is not in use (see the **WARNING** below and the [Install and remove channel blockers](#) (on page 3-7) topic for more information).

⚠ WARNING

Each SMU input on the 4200A-CVIV that is not in use must have its access restricted by an included channel blocker. Failure to use a channel blocker may result in personal injury or death due to electric shock.

To install a preamplifier or pass-through module:

1. Disconnect any cables from the instrument before installing a module.
2. Remove the rubber bumper from the SMU inputs side of the 4200A-CVIV.
3. Using a Phillips-head screwdriver, loosen the two captive screws securing the module door to the instrument.
4. Completely remove the module door and set it aside.
5. Align the module with the alignment rails of a vacant SMU input bay.
6. Firmly insert the module into the instrument until it is seated. Use the following graphics as a guide.

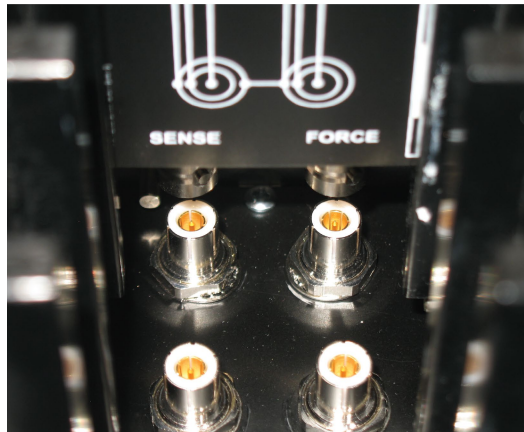
Figure 10: Correct alignment (left) and fully seated module

Correct alignment



Fully seated

CAUTION

Do not use excessive force when installing the preamplifier and pass-thru modules. The modules are designed to fit securely, but extreme pressure may cause damage to the modules or the instrument. Always verify the alignment of the module before inserting it into the 4200A-CVIV.

7. Place channel blockers into any SMU input slots without a module. See the [Install and remove channel blockers](#) (on page 3-7) topic for installation information.
8. Reinstall the module door.
9. Finger-tighten the captive screws on the module door, or use a screwdriver. Do not overtighten.

Reinstall the protective rubber bumper. A 4200A-CVIV with a pass-thru module installed in SMU slot 4 and a preamplifier in slot 3 is shown in the following graphic. Channel blockers are not installed in this graphic.

Figure 11: 4200A-CVIV input panel



To remove a preamplifier or pass-through module:

1. Disconnect any cables from the instrument before installing a module.
2. Remove the rubber bumper from the SMU inputs side of the 4200A-CVIV.
3. Loosen the two captive screws securing the module door to the instrument.
4. Completely remove the module door and set it aside.
5. Grasp the module and pull it straight out of the 4200A-CVIV.

CAUTION

Do not twist the module when removing it from the instrument. Do not use implements to grasp the triaxial connectors of the pass-through or the serial connector of the preamplifier.

6. Place channel blockers into any SMU input bays without a module. See the [Install and remove channel blockers](#) (on page 3-7) topic for more information.
7. Reinstall the module door.
8. Finger-tighten the captive screws on the module door, or use a Phillips screwdriver. Do not overtighten.

Install and remove channel blockers

WARNING

Each SMU input on the 4200A-CVIV that is not in use must have its access restricted by an included channel blocker. Failure to use a channel blocker may result in personal injury or death due to electric shock.

The 4200A-CVIV is shipped with two protective channel blockers. You must install a blocker in each SMU input module location that is not occupied with a 4200-PA Remote Preamplifier or 4200A-CVIV-SPT SMU Pass-Thru Module. The 4200A-CVIV input panel cover and channel blockers are shown in the next figure.

Figure 12: 4200A-CVIV input panel cover and channel blockers

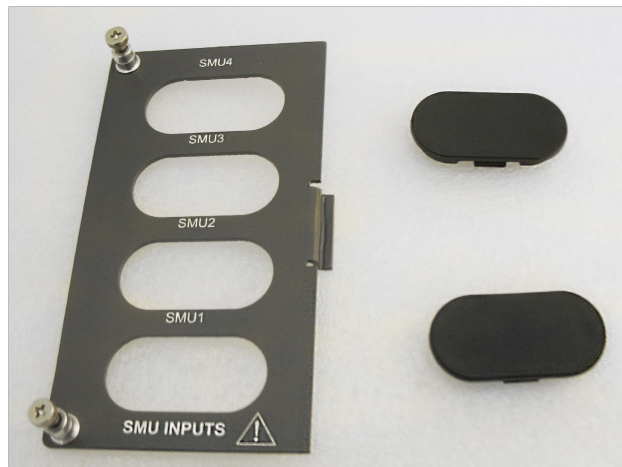

To install a channel blocker:

1. For the vacant channel, place a channel blocker into the opening, smooth side facing out.
2. Press down on the blocker firmly until you hear an audible click. The blocker is now positioned correctly.

NOTE

You may need to slightly press one of the tabs on the edge of the blocker flange before it seats flush with the front of the 4200A-CVIV input panel (see the next figure).

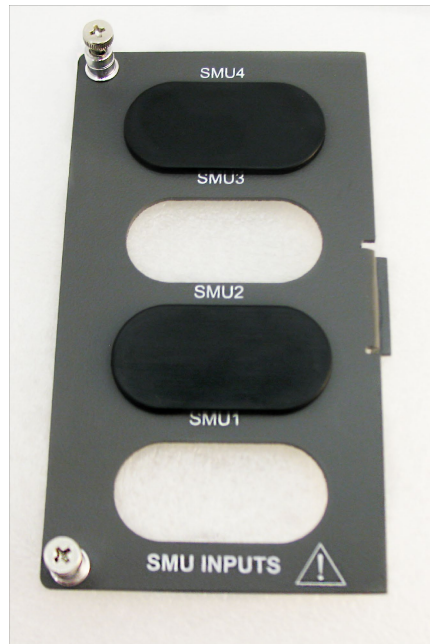
Figure 13: 4200A-CVIV input panel cover with channel blockers installed**To remove a channel blocker:**

On the rear of the panel cover, press one of the tabs on the inside edge of the blocker flange while pushing out. The blocker can now be removed.

CAUTION

To prevent damage to the channel blocker or the input panel, do not use excessive pressure when removing the channel blocker.

Mount the 4200A-CVIV Model 4200A-CVIV

The 4200A-CVIV can be mounted to a flat surface with four #4 screws. Threaded mounting holes are on the top, bottom, and rear panels of the instrument.

NOTE

Be sure to consider your test station layout, ground cable layout, and other cable routing before mounting the instrument.

Figure 14: 4200A-CVIV mounting dimensions

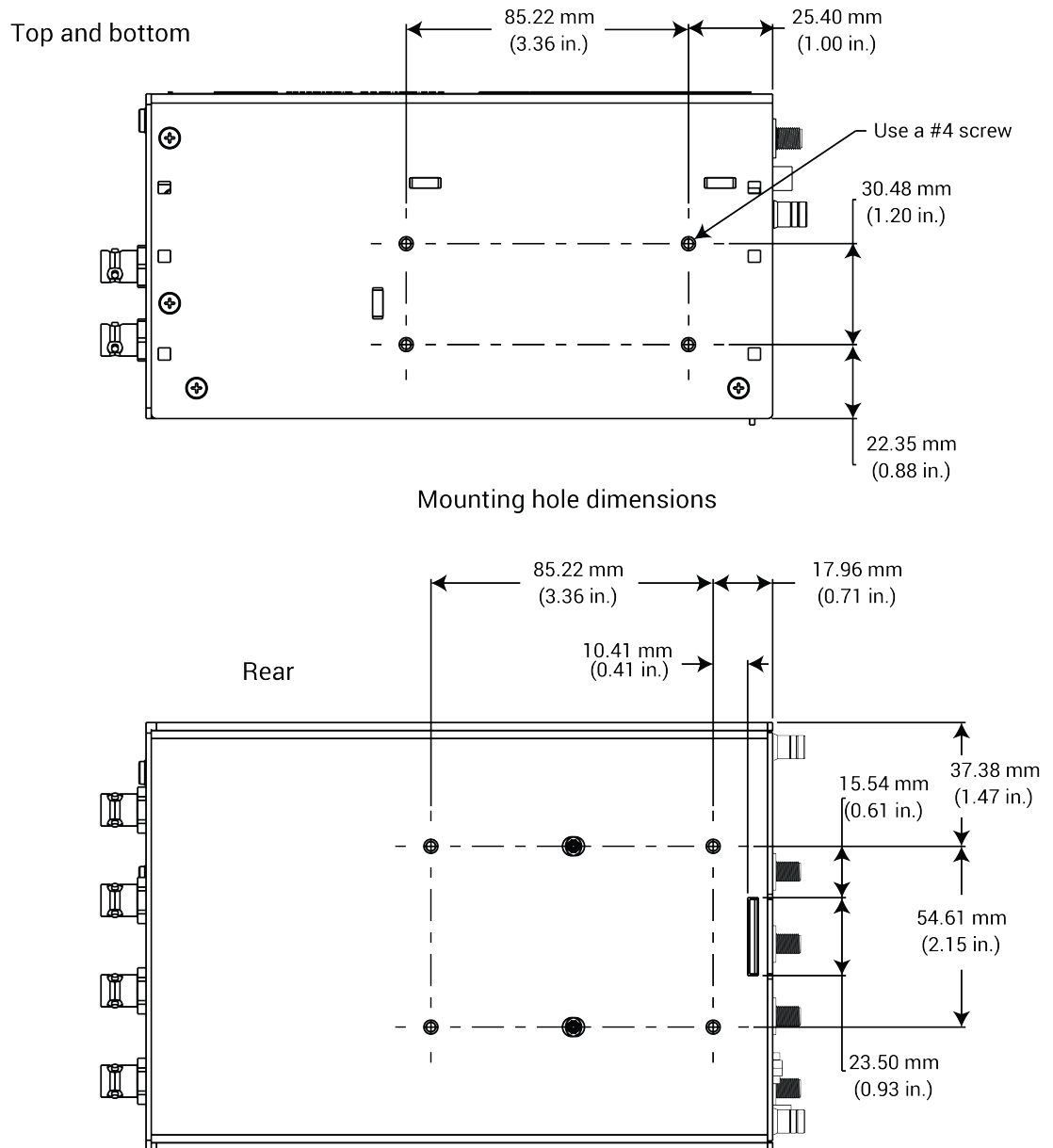

Configure the 4200A-CVIV with KCon

Before using the 4200A-CVIV, you must add the instrument to the 4200A-SCS using the Keithley Instruments Configuration Utility (KCon). This must be done each time an instrument is added, changed, or removed from the 4200A-CVIV. The outputs of the 4200A-CVIV are configured within Clarius+ and are not affected by KCon.

For more information on KCon, see the Keithley Instruments *Model 4200A-SCS Parameter Analyzer Reference Manual*.

To update the Model 4200A-CVIV configuration:

1. Turn off the 4200A-SCS system power.
2. Connect any SMU to one of the 4200A-CVIV input channel slots.
3. Make connections to the 4210-CVU Capacitance-Voltage Unit.
4. Connect the 4200A-CVIV to any USB port on the front or back of the 4200A-SCS using the included USB Type A to USB Type B cable.
5. Turn on the 4200A-SCS system power.
6. Start the KCon application.
7. Select **Update Preamp, RPM, and CVIV Configuration**.
8. Select **Save**.

Switching and software configuration

In this section:

Introduction	4-1
4200A-CVIV switching	4-2
Measurement compensation	4-12
Control the Model 4200A-CVIV with Clarius.....	4-16
Control the 4200A-CVIV with LPT commands	4-26

Introduction

This section of the 4200A-CVIV User's Manual covers the following topics:

- [4200A-CVIV switching modes](#) (on page 4-2)
- [Measurement compensation](#) (on page 4-12)
- [Controlling the 4200A-CVIV with the Clarius application](#) (on page 4-16)
- [Controlling the 4200A-CVIV with LPT commands](#) (on page 4-26)

4200A-CVIV switching

The 4200A-CVIV has the following output modes:

- Open
- SMU
- CV HI
- CV LO
- CV Guard
- Ground Unit
- AC Coup AC Gnd
- BiasT SMU CV HI
- BiasT SMU CV LO
- BiasT SMU LO I CV HI
- BiasT SMU LO I CV LO
- BiasT SMU AC Gnd

Changing the output mode for each channel reconfigures the switches in the 4200A-CVIV to route the correct signal to the output terminal. There is also a global 2-Wire/4-Wire CVU setting that affects all of the channels configured for CV HI and CV LO.

The next figure shows a simplified diagram of the Model 4200A-CVIV. In this diagram, all of the source-sense pairs are shown as a single wire for simplicity. Each channel has its own set of switches that control which input channel is routed to the output connectors. Only one option can be selected for an output at any one time.

The sections following the next figure describe the switching options in more detail.

Figure 15: 4200A-CVIV simplified switching

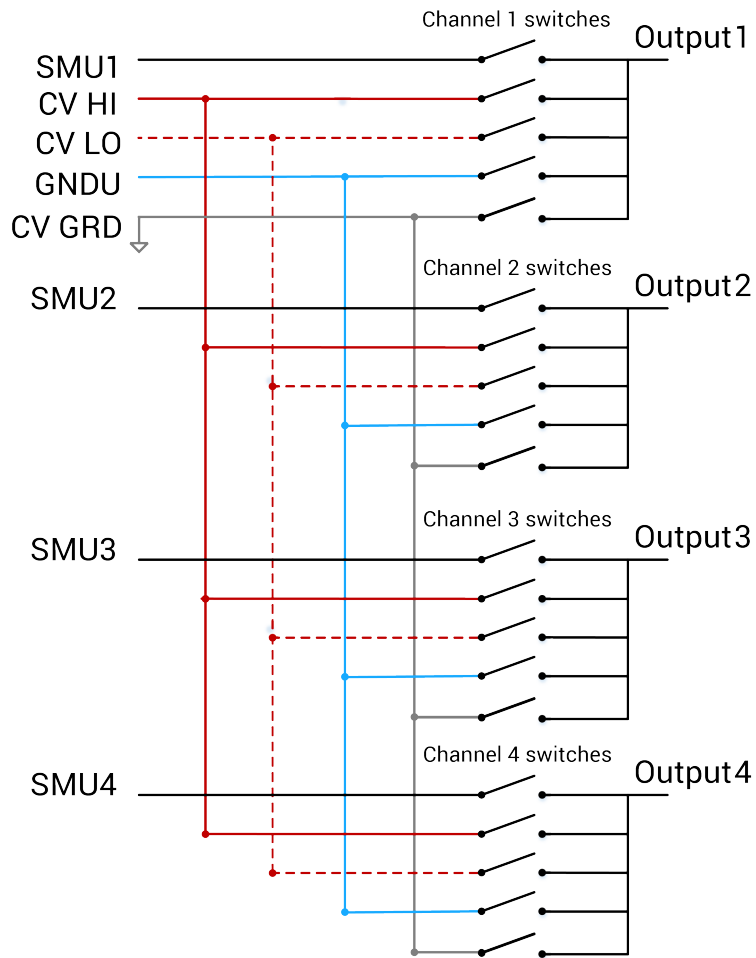

Open

Select the Open setting for an output channel if nothing will be connected to the output terminal. This is the default setting for the channels upon power up. The switches in the previous figure are all shown in the open position.

SMU switching

The 4200A-CVIV can connect and disconnect the force and sense terminals of the SMU channels to the output terminals. For example, select the SMU option for all four channels to perform I-V testing on a four-terminal device. This setting closes the relays that connect the SMU channels to the output connectors. The next figure shows a simplified diagram of the SMU switching configuration.

Figure 16: 4200A-CVIV SMU switching configuration

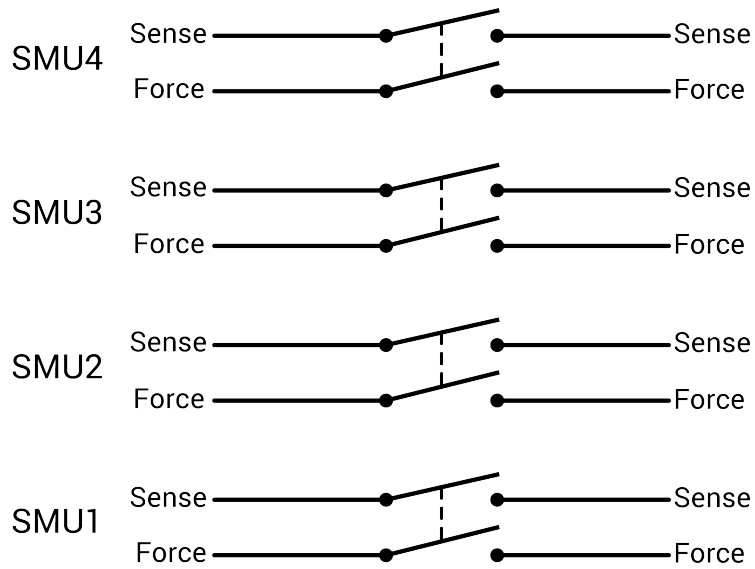

NOTE

The 4200A-CVIV instrument is not a full SMU switching matrix and it is not possible to connect an input SMU channel to a different output channel.

CV HI switching

The 4200A-CVIV can switch the HI connections of the 4210-CVU (HI POT and HI CUR) to any of the output channels. You can make C-V measurements between any set of output terminals. The CV HI setting can also be applied to more than one output terminal at a time if you are connecting multiple device terminals during C-V measurements. The next figure shows a simplified diagram of the CV HI switching configuration.

Figure 17: 4200A-CVIV CV HI switching configuration

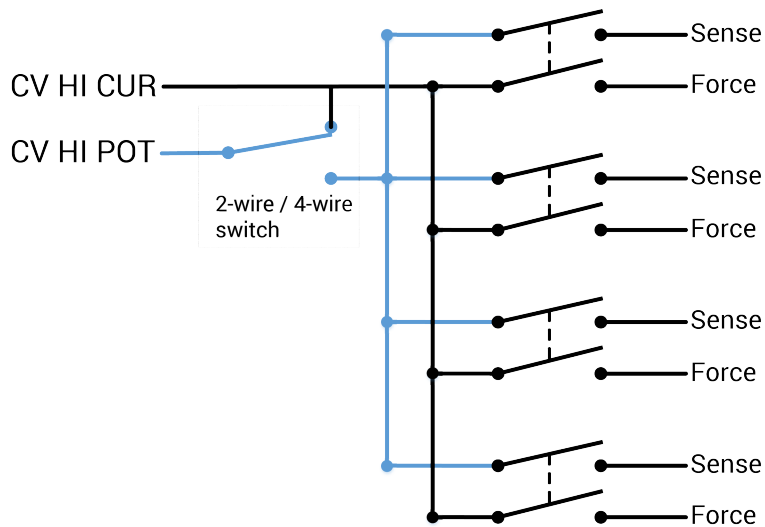

CV LO switching

The 4200A-CVIV can switch the LO connections of the 4210-CVU (LO POT and LO CUR) to any of the output channels. You can perform C-V measurements between any set of output terminals. The CV LO setting can also be applied to more than one output terminal if you are connecting multiple device terminals during C-V measurements. The next figure shows a simplified diagram of the CV LO switching configuration.

Figure 18: 4200A-CVIV CV LO switching configuration

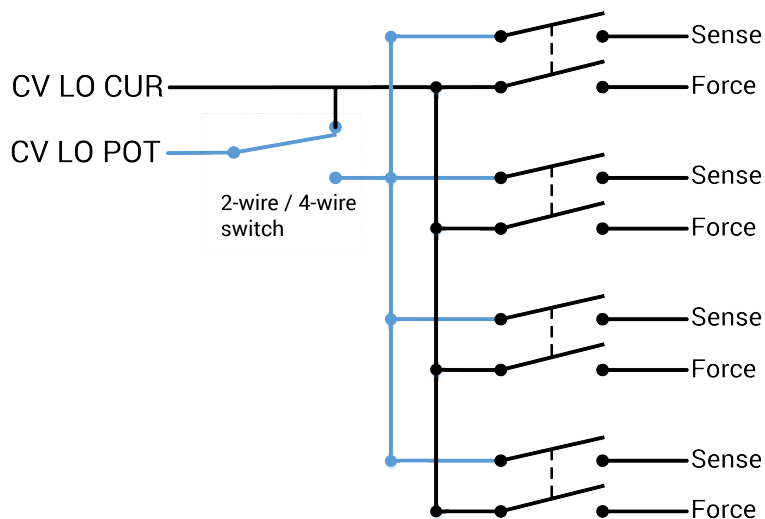

CV Guard switching

The 4200A-CVIV can apply an effective guard signal to any output terminal. You can make C-V measurements while guarding device terminals that should not be included in the measurement. The CV GRD setting can also be applied to more than one output terminal at a time if you are guarding multiple device terminals during C-V measurements.

The next figure shows a simplified diagram of the CV GRD switching configuration. This mode provides an AC low impedance ground return through the 4200A-CVIV to be used for guarding out terminals used in CV measurements.

Figure 19: 4200A-CVIV CV GRD switching configuration

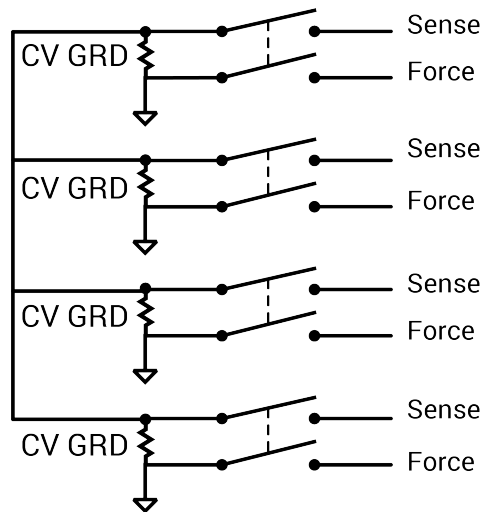

NOTE

The CV GRD mode cannot be used as a DC ground for SMUs in a test configuration. Model 4200A-SCS ground unit multiplexing is available for the 4200A-CVIV with hardware version 2.0 or later. See [Ground unit switching](#) (on page 4-7) for more information.

Ground unit switching

The 4200A-CVIV supports a ground unit (GNDU) that can be switched to any one of the four output channels. You can use a miniature triaxial to triaxial cable assembly to connect GNDU SENSE on the 4200A-CVIV to the SENSE connector of the ground unit on the 4200A-SCS. You do not need to make a physical connection between the FORCE connection of the Model 4200A-SCS ground unit and the Model 4200A-CVIV, as the connection is made through the outer shield of the triaxial cable.

Keithley Instruments does not recommend configuring multiple GNDU channels when GNDU SENSE is connected. Different terminals can have different potentials, which may cause measurement errors.

The GNDU detects whether the test configuration is 2-wire or 4-wire.

NOTE

The ground unit switching mode is only available with 4200A-CVIV hardware versions 2.0 or newer.

Figure 20: 4200A-CVIV GNDU switching configuration

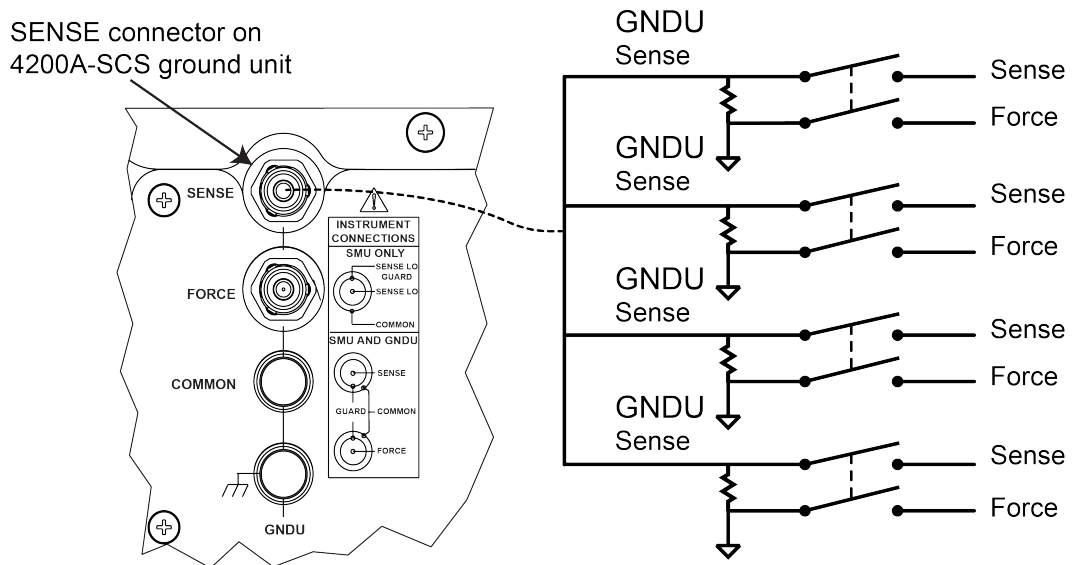

AC coupled AC ground configuration

The next figure shows a 4200A-CVIV AC coupled with AC ground configuration. This mode provides an AC-coupled, low-impedance return to ground through the 4200A-CVIV, and also blocks the DC component of the signal. This configuration allows the DC signal to float, and the AC signal is grounded.

A typical application for this configuration would be when performing a C-V measurement on a three-terminal device. Two of the terminals would be designated as CV HI and CV LO, and the third terminal would be grounded through a capacitor. DC bias is provided by the DUT, while the AC signal is grounded.

Figure 21: 4200A-CVIV AC coupled AC ground configuration

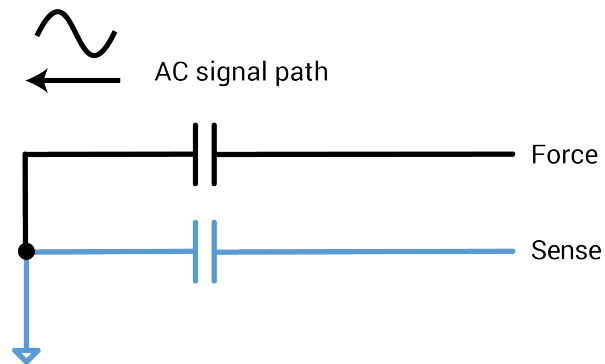

Bias tee switching

The 4200A-CVIV supports a bias tee on each of its four channels to allow DC biasing of AC signals at the channel outputs. The bias tee modes use the CVU to measure the capacitance and the SMUs to sweep the voltage or apply a DC bias of up to + / - 200 V, or 400 V differential. The bias tees also enable a current compliance of up to 100 mA or 1 A, depending on the SMU.

NOTE

Bias tee configuration modes are for C-V measurements only. For I-V measurements, use the SMU configuration mode.

You can select bias tee modes in Clarius+, as shown in the next figure. The `CvsT` and `SweepV` tests in the `hivcvulib` user library can be used with the bias tee modes.

Figure 22: Bias tee mode selection

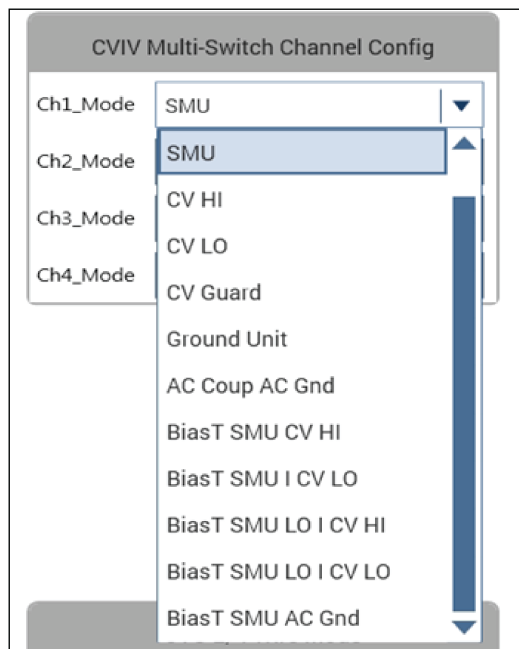

The next figure shows a 4200A-CVIV bias tee high-current SMU configuration with a CV HI or LO switching configuration. This combines the DC bias from a Model 4200-SMU or 4210-SMU with an AC signal from CV HI or LO through a 4200A-CVIV bias tee circuit. This mode is ideal for performing C-V measurements where a DC bias current of up to 1 A is required, such as when making C-V measurements on a semiconductor in the on-state.

Figure 23: 4200A-CVIV bias tee, high current SMU CV HI or LO switching configuration

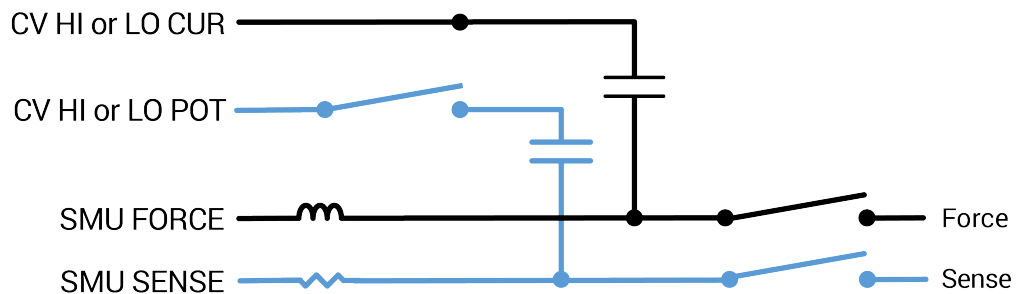

The next figure shows a 4200A-CVIV bias tee low-current SMU CV HI or LO switching configuration. This combines the DC bias from a 4200-SMU or 4210-SMU with an AC signal from CV HI or LO through the 4200A-CVIV bias tee circuit. This mode is optimized for use with currents below 100 μ A, and is the preferred mode for semiconductors in the off-state.

Figure 24: 4200A-CVIV bias tee, low current SMU CV HI or LO switching configuration

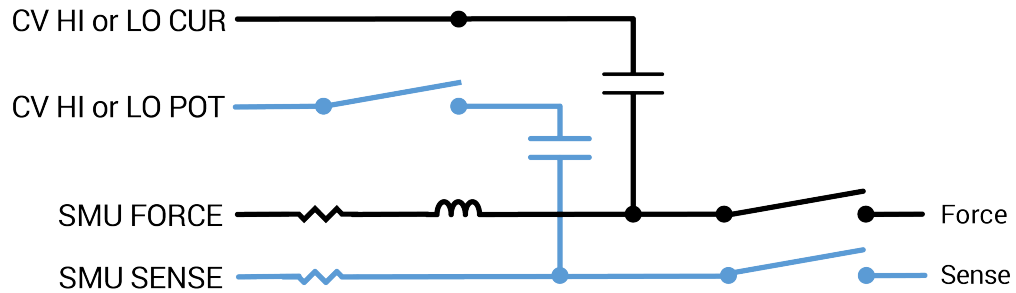

Bias tee SMU AC ground

The next figure shows a 4200A-CVIV bias tee with an AC ground configuration. This combines the DC bias from a 4200-SMU or 4210-SMU with local AC ground through the 4200A-CVIV bias tee circuit.

A typical application for this configuration would be when performing a C-V measurement on the drain to the source of a MOSFET while applying a DC bias to the gate. AC signals at the gate would have a ground return path.

Figure 25: 4200A-CVIV bias tee AC ground configuration

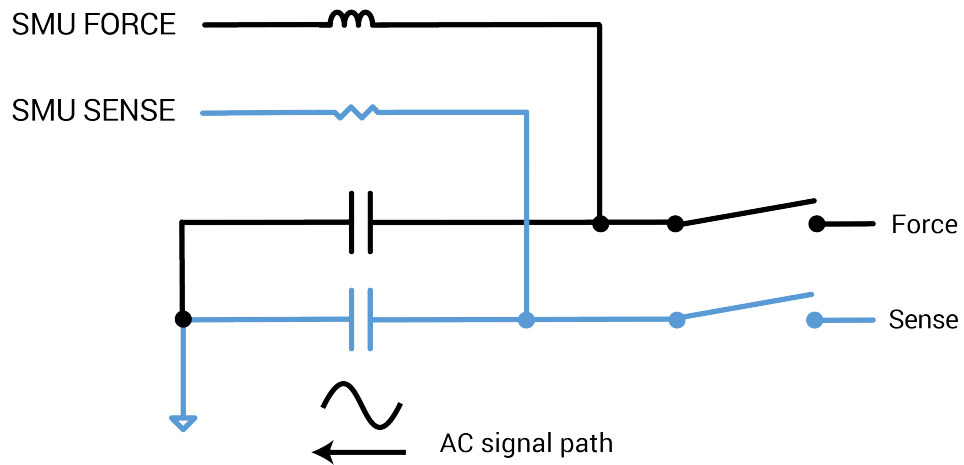

Automate switching between 2-wire and 4-wire mode

C-V measurements are typically performed in 4-wire mode with each source and sense pair (HI CUR/HI POT pair and LO CUR/LO POT pair) terminated together as close to the device under test (DUT) as possible. However, this setup can become difficult in switching applications where I-V and C-V measurements are made using the same cabling. The 4200A-CVIV can make 4-wire measurements, but it can also switch to 2-wire measurements when only two cables are connected to the DUT.

In 2-wire C-V mode, the source and sense pairs are terminated together internally and the coupled signal is passed to the selected output terminal on the source signal line. This setup is useful when you want to run the fewest number of triaxial cables to the DUT or if you are only making 2-wire I-V measurements and do not want to run extra triaxial cables for the C-V measurements. The next figure shows the CV HI and CV LO circuits in 2-wire mode. The output channel switches are omitted in the figure.

Figure 26: 4200A-CVIV CV HI and CV LO channels configured in 2-wire sense mode

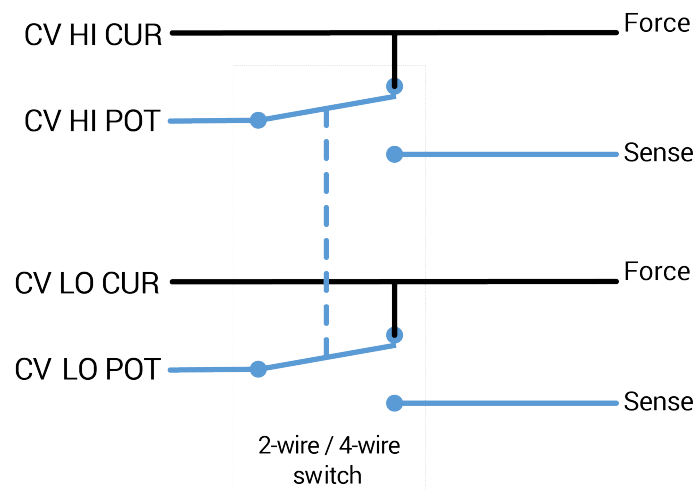

In 4-wire C-V mode, the source and sense pairs are independent of each other as they pass through the 4200A-CVIV. The HI CUR and LO CUR signals are routed directly to the source output terminal of the specified output channel and the HI POT and LO POT signals are routed directly to the sense output terminal of the specified output channel. This setup is useful if you already have 4-wire Kelvin connections to the DUT for I-V testing. The next figure shows the CV HI and CV LO circuits in 4-wire mode. The output channel switches are omitted in the figure.

Figure 27: 4200A-CVIV CVHI and CVLO channels configured in the 4-wire sense mode

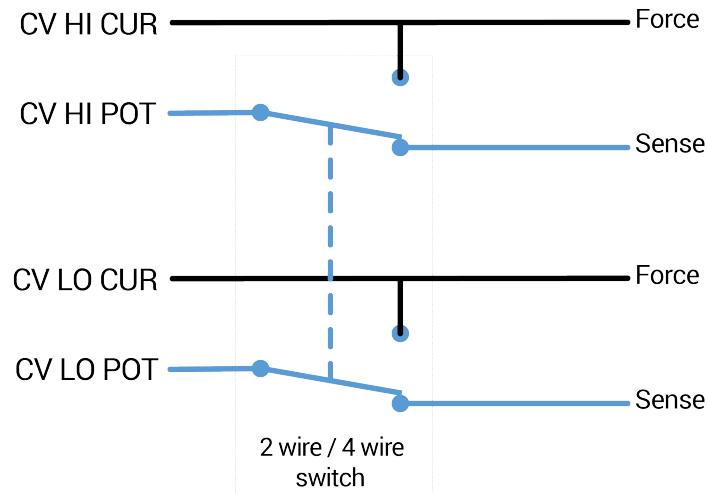

It is best to use 4-wire mode for measuring low impedance in both I-V and C-V applications. Four-wire mode removes the effect of the cable impedance by sensing voltage directly at the device terminals. The effect of cable impedance is more pronounced with low impedance devices because parasitic impedance in the cabling can become larger than that of the device itself.

Measurement compensation

Using the 4200A-CVIV with a 4210-CVU causes some degradation in CVU measurement accuracy. To resolve this, perform compensation with the 4200A-CVIV.

You run the `cvu-comp-cviv-collect` action in Clarius+ to gather open, short, and load compensation values that you apply to CVU readings.

CVU compensation

Offset and gain errors caused by the connections between the 4210-CVU, 4200A-CVIV, and the device under test (DUT) can be corrected by using connection compensation. General CVU compensation is a two-part process:

1. Generate connection compensation values for open, short, and load conditions. The compensation values are stored for future use.
2. Enable the compensation values for open, short, or load before running the interactive test module (ITM).

When using the 4200A-CVIV, perform compensation for each switch configuration used for C-V measurements in the test application. For example, perform compensation three times (one time for each C-V setup) if you plan to switch between three different C-V measurement setups on the terminals of a 3-terminal device.

The compensation values for all 4200A-CVIV configurations are stored by the Clarius⁺ software. When you run a test, the enabled compensation values are factored into each measurement. If you do not perform compensation for the current 4200A-CVIV configuration, the software will use the default compensation constants, which are equivalent to no compensation. If you disable open, short, and load compensation in a test, the software does not apply the compensation values to the test results.

NOTE

Perform connection compensation any time the connection setup is changed or disturbed. Changes in temperature or humidity do not affect connection compensation.

Guidelines to determine required compensation

Use the following general guidelines to determine which compensation needs to be done:

- **Open** compensation: Offset compensation for small capacitance ($> 1 \text{ M}\Omega$, large impedance)
- **Short** compensation: Offset compensation for large capacitance ($< 10 \text{ }\Omega$, small impedance)
- **Load** compensation: Resistive load compensation for gain error (seldom used)

Once you complete compensation for a specific 4200A-CVIV configuration, it is not necessary to gather compensation values each time you switch back to that configuration. However, over time the compensation values required for each configuration can drift from their original value. To avoid this, gather compensation values periodically for each switching configuration to make sure that the system is using the most accurate compensation values.

Model 4200A-CVIV compensation connections

Connect the output cables for open, short, or load compensation. Repeat this process for each channel configuration being compensated. The following figure examples are shown using channels 1 and 2, but the same connection scheme applies for any channel configuration. The next figure shows the connections for 2-wire and 4-wire open compensation. In 2-wire mode, leave the ends of the triaxial cables disconnected. In 4-wire mode, connect the force and sense triaxial cables for each channel with a triaxial tee connector.

For all compensation connections, make sure that the outer shields of the triaxial cables are shorted together as close to the DUT as possible for optimal measurements. This is commonly done by attaching the triaxial connectors to a test fixture.

See the *Model 4200A-SCS Reference Manual* for additional compensation information

NOTE

The DUT side of the 4200A-CVIV is intended to be used only with the 4200-TRX-0.75 or CA-534-24A blue triaxial cables. 4-wire connection compensation not supported with other cables.

Figure 28: Connections for open connection compensation

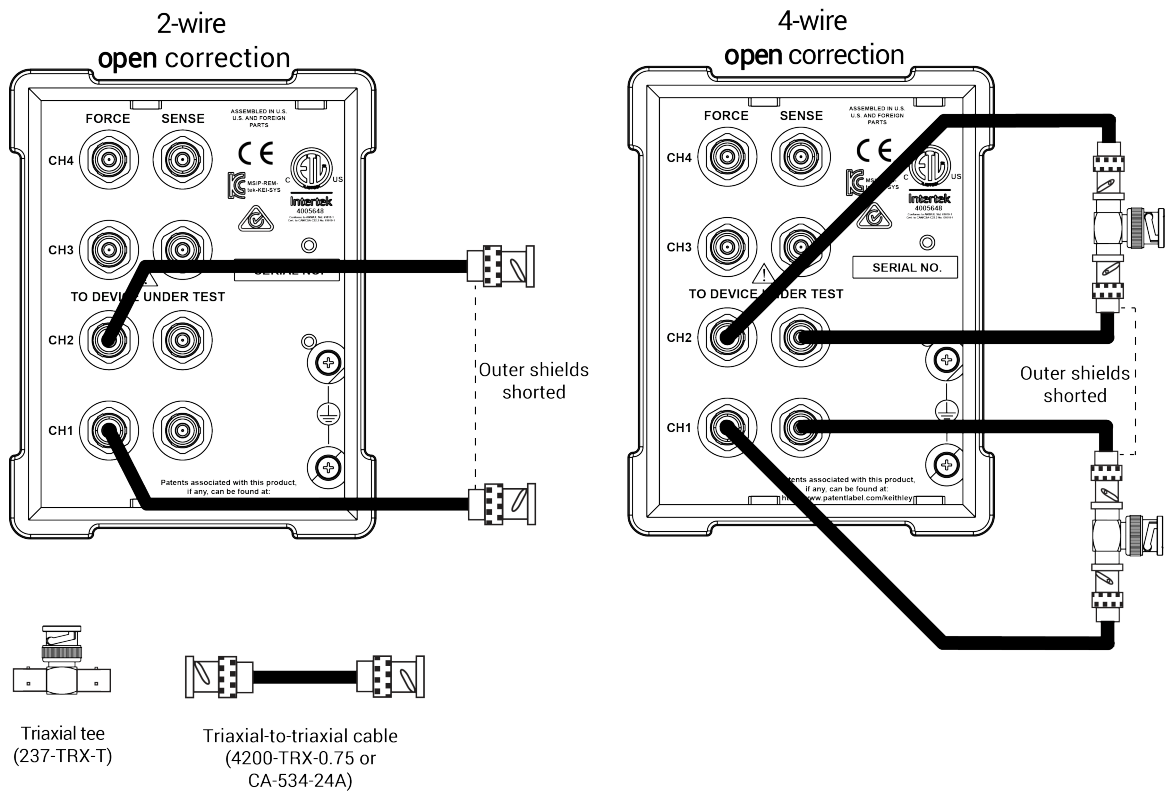

The next figure shows the connections for 2-wire and 4-wire short compensation. In 2-wire mode, short the force leads at the test fixture or at a probe station. In 4-wire mode, connect the force and sense triaxial cables for each channel with a triaxial tee connector. Short the outputs at the test fixture or at a probe station.

Figure 29: Connections for short connection compensation

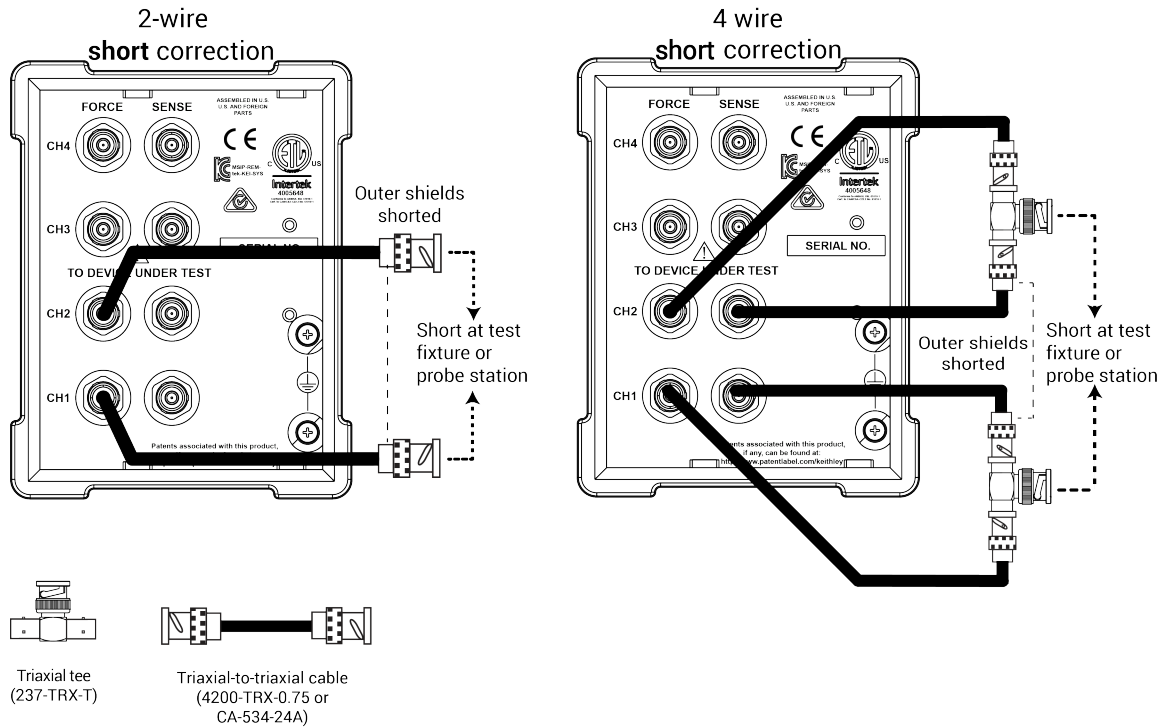

The next figure shows the connections for 2-wire and 4-wire load compensation. In 2-wire mode, connect the ends of the triaxial cables to the load. The load can be in a test fixture or a probe station. In 4-wire mode, connect the force and sense triaxial cables for each channel with a triaxial tee connector. Connect the triaxial tee outputs to the load.

Figure 30: Connections for load connection compensation

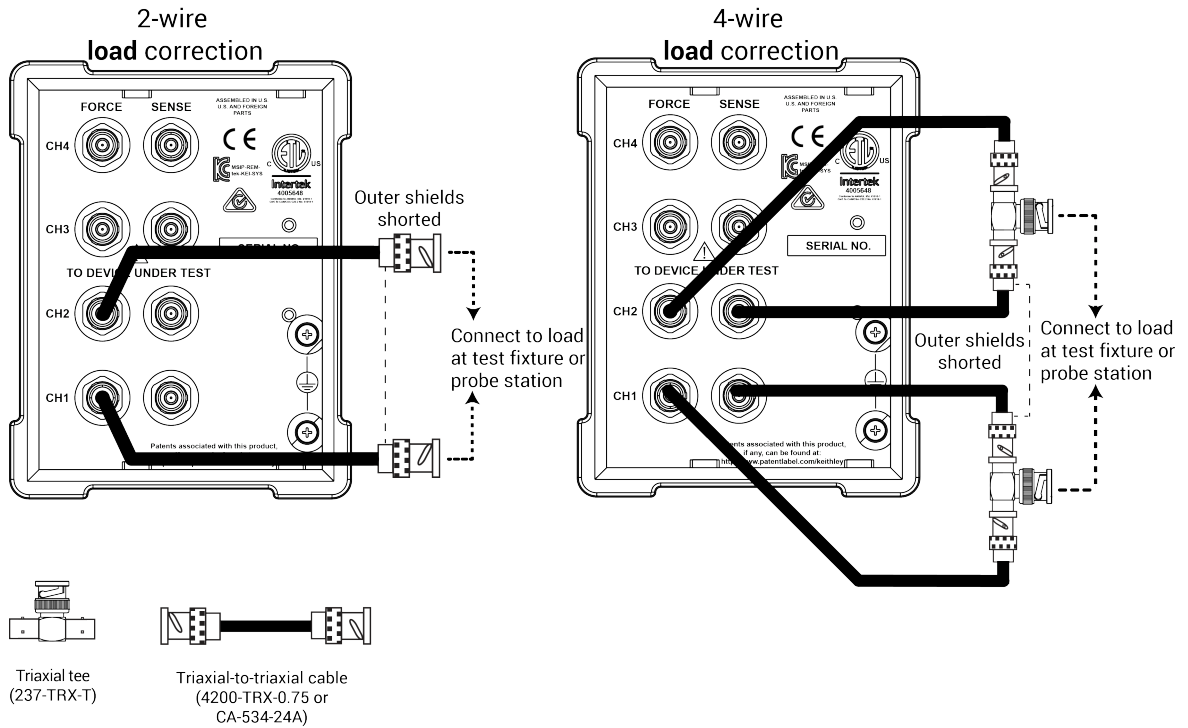

Control the Model 4200A-CVIV with Clarius

The Keithley Instruments Clarius+ software is pre-installed on your 4200A-SCS Parameter Analyzer. You can use Clarius+ to control the outputs of your 4200A-CVIV and its onboard display.

There are two actions built into the Clarius+ software on the 4200A-SCS that are used to control the 4200A-CVIV: `cviv-configure` and `cvu-cviv-comp-collect`. Each of these actions is also available as a user module in the `cvivulib` user library.

For more information on Clarius+, see the *Model 4200A-SCS Parameter Analyzer Reference Manual*.

cviv-configure

The `cviv-configure` action is used to set up and control the 4200A-CVIV output channels when performing a C-V or I-V test. To use the action, add it to the project tree structure and execute it when you want to reconfigure channels. The `cviv-configure` action can control the channel configuration, 2-wire and 4-wire CVU sense settings, and the names of the test and channels shown on the 4200A-CVIV display. The parameters for the action are shown in the table following the graphic.

Figure 31: Clarius+ cviv-configure action

Adjustable parameters in the cviv-configure module

Detailed descriptions of the input parameters are as follows:

Ch1-4Mode: The instrument terminal that will be connected to an output channel specified by numbers 1 through 4. The options are:

- **Open:** No Connection. The output channel will be an open circuit.
- **SMU:** The output channel signals will pass through the SMU terminals.
- **CV HI:** The output channel will be connected to the CVU HI side terminals.
- **CV LO:** The output channel will be connected to the CVU LO side terminals.
- **CV Guard:** The output channel will be connected to the guard (outside shield) of the CVU cables.
- **GNDU:** The output channel will be connected to the SENSE connector of the ground unit on the 4200A-SCS.
- **AC Coup AC Gnd:** The output channel will be connected to AC-coupled AC ground.
- **BiasT: SMU CV HI:** The output channel will be connected to the SMU and the CVU HI side terminals.
- **BiasT: SMU CV LO:** The output channel will be connected to the SMU and the CVU LO side terminals.
- **BiasT: SMU LO I CV HI:** The output channel will be connected to the SMU and the CVU HI side terminals. This parameter is optimized for lower SMU current (I).
- **BiasT: SMU LO I CV LO:** The output channel will be connected to the SMU and the CVU LO side terminals. This parameter is optimized for lower SMU current (I) .
- **BiasT: SMU AC Gnd:** The output channel will be connected directly to ground and the SMU through the bias tee.

CH1-4TermName: Up to six characters of text that will appear on the 4200A-CVIV display next to the output channel specified by numbers 1 through 4.

TestName: Up to sixteen characters of text that will appear at the top of the 4200A-CVIV display. This allows you to enter a name for the test.

TwoWireMode: Selects whether the 4210-CVU will output in two-wire or four-wire mode. This affects all output channels configured to CV HI or CV LO. Output channels configured to SMU or CV Guard are not affected.

- **Two Wire:** The sense output terminal is not used. The CUR and POT lines of CV HI or CV LO are shorted internally and connected to the force terminal of any output channel(s) specified by **Ch1-4Mode**.
- **Four Wire:** The POT and CUR lines of CV HI and CV LO are not shorted internally. POT is connected to sense while CUR is connected to force for any output channel specified by **Ch1-4Mode**.

cviv-configure return values

Two values are returned from `cviv-configure` to the Analyze sheet. The `cviv_configure` value returns a status number to indicate how the test completed. The `ConstantsName` value returns the configuration settings in the form of a short string of text used when CVU compensation is performed.

Figure 32: Analyze view of the completed cviv-configure action (no errors returned)

The screenshot shows the 'cviv-configure#1' Analyze view. At the top, there is a title 'cviv-configure#1' and a 'View:' button. Below the title is a 'Run8 Formulas List' dropdown menu. To the right of the dropdown are 'Save Data' and 'Edit' buttons. The main area contains a table with two columns, A and B, and rows numbered 1 through 10. The data in the table is as follows:

	A	B
1	cviv_configure	ConstantsName
2	0	constants_1_2_3_0_0
3		
4		
5		
6		
7		
8		
9		
10		

At the bottom of the window, there is a navigation bar with the text 'Run8 / Calc / Settings /'.

Detailed descriptions of the return parameters are as follows:

`cviv_configure`: A value that indicates if the action completed with any errors. The following values are the possible parameters.

- 0: Pass (no errors)
- -1: Invalid CVIV instrument Id
- -2: Display configuration error
- -78: Received Timeout Waiting for CVIV Response
- -88: Bad Configuration of Data Sent to CVIV
- -122: Invalid parameter
- -150: CVIV Device Not Found
- -167: Invalid CVIV Connection Configuration
- -169: CVIV Unit Name not configured

NOTE

If you receive -1, -150, or -169, run the KCon application and select the Validate Configuration option.

`ConstantsName`: The name of the file contains the 4200A-CVIV configuration set in the user module. Any CVU tests run after the `cviv-configure` action use this file and its contents.

The format of the string is:

```
constants_<2W/4W>_<Ch1_Mode>_<Ch2_Mode>_<Ch3_Mode>_<Ch4_Mode>_<cable
length>
```

The possible values are:

- <2W/4W>: 0 = 4-wire, 1 = 2-wire
- <Ch_Mode>: 0 = open, 1 = SMU, 2 = CV HI, 3 = CV LO, 4 = CV Guard 5 = Ground Unit, 6 = AC Coup AC Gnd, 7 = BiasT: SMU CV HI, 8 = BiasT: SMU CV LO, 9 = BiasT: SMU LO I CV HI, 10 = BiasT: SMU LO I CV LO, 11 = BiasT: SMU AC Gnd
- <cable length>:
 - 0 = 0 m
 - 1 = 1.5 m
 - 2 = 3 m
 - 3 = Custom
 - 4 = 1.5 m CVIV 2-wire
 - 5 = 1.5 m CVIV 4-wire 0.75 m (for use with the 4200-TRX-0.75 triaxial cables)
 - 6 = 1.5 m CVIV 4-wire 0.61 m (for use with CA-534-24A blue triaxial cables)

For example, `constants_1_2_3_0_0_4` signifies 2-wire mode, CV HI connected to channel 1, CV LO connected to channel 2, open connections for channels 3 and 4, and a cable length of 1.5 m CVIV 2-wire.

cvu-cviv-comp-collect

The `cvu-cviv-comp-collect` action is used to perform open, short, and load compensations on the 4200A-CVIV channels before running a C-V test. The action will configure the 4200A-CVIV channels before performing compensation, so it is not necessary to use the `cviv-configure` action before compensation. To use this action, it must be added into the project tree structure and executed once for each C-V measurement configuration used in the project.

The parameters in `cvu-cviv-comp-collect` are used to define the connections to the 4200A-CVIV output channels that will be used in your test. You must run the action for each 4200A-CVIV configuration that will be used, as compensation values are unique for each configuration. Details on each parameter are listed in this topic.

If more than one type of compensation is selected, open compensation is done first, then short, then load. Dialog boxes will prompt you to make the proper connections as described in [Compensations](#) (on page 4-12). To learn more about compensation and the connections required for each type, see the [Compensations](#) (on page 4-12) topic. For a specific example of how to set up a project that includes CVIV compensation switching in Clarius+, see the *Model 4200A-SCS Parameter Analyzer User's Manual*.

Figure 33: Clarius+ cvu-cviv-comp-collect action

Input parameters in the cvu-cviv-comp-collect action

Checkbox	Range	Description
CableLength	<ul style="list-style-type: none"> 1.5 m CVIV 2 wire 1.5 m CVIV 4 wire, 0.75 m 1.5 m CVIV 4 wire, 0.61 m, blue 	<p>Length of the cables from the output channels of the DUT to the Model 4200A-CVIV.</p> <p>The 1.5 m CVIV 4 wire, 0.75 m parameter is intended for use with 4200-TRX-0.75 triaxial cables.</p> <p>The 1.5 m CVIV 4 wire, 0.61 m parameter is intended for use with CA-534-24A blue triaxial cables.</p>
Select_Open	Selected or cleared	Selects whether to perform open compensation
Select_Short	Selected or cleared	Selects whether to perform short compensation
Select_Load	Selected or cleared	Selects whether to perform load compensation
LoadValue	0 to 10e3	The value of the resistance standard (in Ω) to be used in load compensation
Ch1-4_Mode	Open, SMU, CV HI, CV LO, CV Guard, Ground Unit, AC Coup AC Gnd, BiasT: SMU CV HI, BiasT: SMU CV LO, BiasT: SMU CV LO, BiasT: SMU LO I CV HI, BiasT: SMU LO I CV LO, BiasT: SMU AC Gnd	The instrument terminal that will be connected to the corresponding output channel
CV_2W_Mode	Two Wire, Four Wire	Selects whether the 4210-CVU terminals will be shorted internally (Two Wire) or not (Four Wire)
Ch1-4_TermName	Up to 6 alphanumeric characters	Text that will appear on the 4200A-CVIV display labeling the corresponding output channel
TestName	Up to 16 alphanumeric characters	Text that will appear at the top of the 4200A-CVIV display

Detailed descriptions of the input parameters are as follows:

CableLength: For the most accurate results, the cables from the output channels of the 4200A-CVIV must all be the same length. The recommended length is 75 cm, though other lengths can be used.

Select_Open: Select this box to have open compensation be performed when the action is executed.

Select_Short: Select this box to have short compensation be performed when the action is executed.

Select_Load: Select this box to have load compensation be performed when the action is executed.

LoadValue: The value of the resistance standard (in Ω) used in the load compensation. Preferred values range from 0 to 200 Ω , but any value up to 10 k Ω may be used. This value is not used if `Select_Load` is cleared.

Ch1-4_Mode: The instruments to be connected to each respective output channel. These must be the same connections that will be used in the `cviv-configure` action when you execute your test.

CV_2W_Mode: Selects whether the 4210-CVU will be in 2-wire or 4-wire mode. This must be the same setting that will be used in the `cviv-configure` action when you execute your test.

Ch1-4_TermName: Text that will appear on the 4200A-CVIV display when the action is running, labeling the corresponding output channel. The text here does not affect compensation.

TestName: Text that will appear at the top of the 4200A-CVIV display while the action is running. The text here does not affect compensation.

cvu-cviv-comp-collect return values

Two values are returned from `cvu-cviv-comp-collect` to the Analyze sheet. The `cvu_cviv_comp_collect` value returns a status number to indicate how the test completed. The `ConstantsName` value returns a string that contains the coded configuration settings.

Figure 34: Analyze view of the completed cvu-cviv-comp-collect action

	A	B
1	cvu_cviv_comp	ConstantsName
2	0	constants_1_2_3_0_0
3		
4		
5		
6		
7		
8		
9		
10		

Detailed descriptions of the return parameters are as follows:

`cvu-cviv-comp-collect`: A value that indicates if the Action completed with any errors. Possible values and associated explanations are:

- 0 : Pass (no errors)
- -1 : Invalid CVU instrument identification
- -2 : Invalid CVIV instrument identification
- -3 : Error: No CV HI connection configured
- -4 : Error: No CV LO connection configured
- -5 : Display configuration error
- -6 : Load Value out of range (0 to 10 K)
- -78 : Receive timeout waiting for CVIV response
- -88 : Bad configuration of data sent to CVIV instrument
- -122 : Invalid parameter
- -150 : CVIV device not found
- -167 : Invalid CVIV connection configuration
- -169 : CVIV instrument name not configured

NOTE

If you receive the -2, -150, or -169 return values, run the KCon application and select the Validate Configuration option.

`ConstantsName`: This is the CVU compensation file containing open, short, and load correction values. The name of the file contains the Model 4200A-CVIV configuration set in the user module. Any CVU tests run after the `cvu-cviv-comp-collect` action use this file and its contents.

The format of the string is:

```
constants_<2W/4W>_<Ch1_Mode>_<Ch2_Mode>_<Ch3_Mode>_<Ch4_Mode>_<cable length>
```

The possible values are:

- <2W/4W> : 0 = 4-wire, 1 = 2-wire
- <Ch_Mode> : 0 = open, 1 = SMU, 2 = CV HI, 3 = CV LO, 4 = CV Guard 5 = Ground Unit, 6 = AC Coup AC Gnd, 7 = BiasT: SMU CV HI, 8 = BiasT: SMU CV LO, 9 = BiasT: SMU LO I CV HI, 10 = BiasT: SMU LO I CV LO, 11 = BiasT: SMU AC Gnd
- <cable length>:
 - 0 = 0 m
 - 1 = 1.5 m
 - 2 = 3 m
 - 3 = Custom
 - 4 = 1.5 m CVIV 2-wire
 - 5 = 1.5 m CVIV 4-wire 0.75 m (for use with the 4200-TRX-0.75 triaxial cables)
 - 6 = 1.5 m CVIV 4-wire 0.61 m (for use with CA-534-24A blue triaxial cables)

For example, `constants_1_2_3_0_0_4` signifies 2-wire mode, CV HI connected to channel 1, CV LO connected to channel 2, open connections for channels 3 and 4, and a cable length of 1.5 m CVIV 2-wire.

Enable compensation for a test

After you use the `cvu-cviv-comp-collect` action to gather compensation values for the channels of the 4200A-CVIV, you must enable the compensation for the test you want to run.

To enable compensation for a test:

1. Make sure that the `cviv-configure` action has been placed into the project tree before your C-V test.
2. In the project tree, select the C-V test that you want to apply compensation to.
3. Select **Configure**.

Figure 35: Configure selected

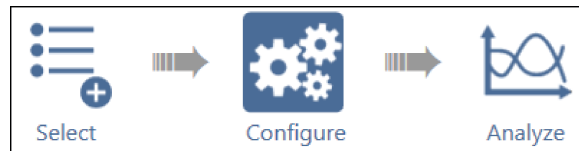

- From the Terminal Settings pane, select the type of compensation you want to perform.

Figure 36: Enabling open compensation for the test

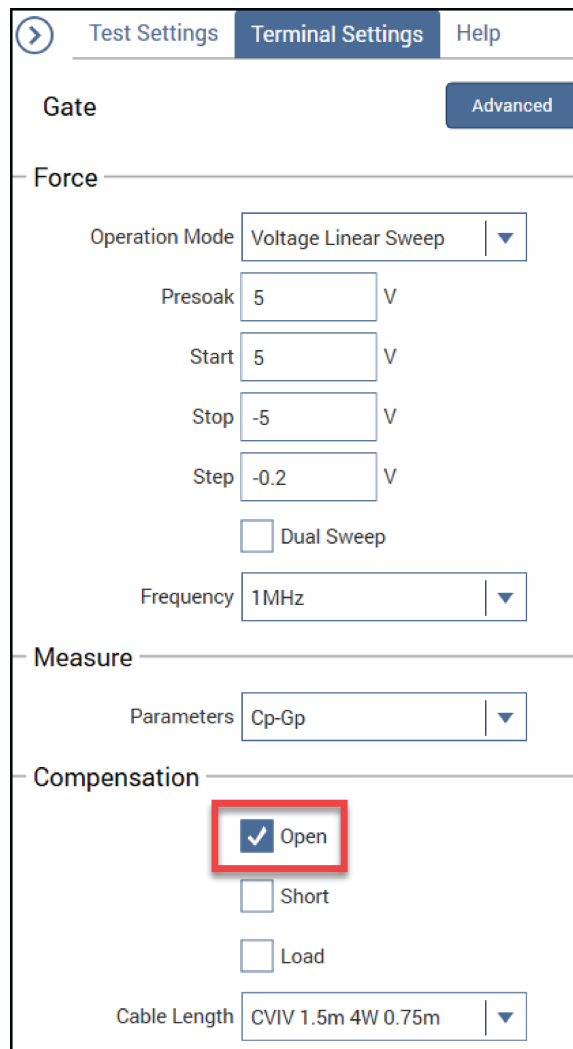

The screenshot shows the 'Terminal Settings' pane with the following configuration:

- Gate:** Advanced
- Force:**
 - Operation Mode: Voltage Linear Sweep
 - Presoak: 5 V
 - Start: 5 V
 - Stop: -5 V
 - Step: -0.2 V
 - Dual Sweep:
 - Frequency: 1MHz
- Measure:**
 - Parameters: Cp-Gp
- Compensation:**
 - Open
 - Short
 - Load
 - Cable Length: CVIV 1.5m 4W 0.75m

- Select **Run** to run the test. The compensation values are applied to the measurements.

Control the 4200A-CVIV with LPT commands

The 4200A-CVIV can be controlled through LPT commands if you want to configure the CVIV outputs or display from inside a user module created with the Keithley User Library Tool (KULT).

For more information on KULT, see the *Model 4200A-SCS Parameter Analyzer Reference Manual*.

cviv_config

This command sends switching commands to the 4200A-CVIV Multi-Switch.

Usage

```
int cviv_config(int instr_id, int channel, int mode);
```

<i>instr_id</i>	The instrument identification code of the 4200A-CVIV: CVIV1
<i>channel</i>	4200A-CVIV channel: 1 to 4 4200A-CVIV all channels: 5
<i>mode</i>	<p>For channels 1 to 4, the switch settings for the selected channel:</p> <ul style="list-style-type: none"> • Open connection to output terminal: <code>KI_CVIV_OPEN</code> or 0 • Connect channel to SMU (4200-SMU or 4210-SMU): <code>KI_CVIV_SMU</code> or 1 • Connect channel to CVU HI (4210-CVU): <code>KI_CVIV_CVH</code> or 2 • Connect channel to CVU LO (4210-CVU): <code>KI_CVIV_CVL</code> or 3 • Connect CV guard to the output connector shell with AC ground to center: <code>KI_CVIV_CV_GRD</code> or 4 • Connect channel to ground unit: <code>KI_CVIV_GNDU</code> or 5 • Connect channel to AC-coupled AC ground: <code>KI_CVIV_AC_COUPLED_AC_GND</code> or 6 • Connect channel to bias tee SMU CV HI: <code>KI_CVIV_BT_CVH</code> or 7 • Connect channel to bias tee SMU CV LO: <code>KI_CVIV_BT_CVL</code> or 8 • Connect channel to bias tee low current SMU CV HI: <code>KI_CVIV_BT_LOI_CVH</code> or 9 • Connect channel to bias tee low current SMU CV LO: <code>KI_CVIV_BT_LOI_CVL</code> or 10 • Connect channel to bias tee AC ground: <code>KI_CVIV_BT_AC_GND</code> or 11 <p>If <i>channel</i> is set to 5 (all channels), the switch settings for the Model 4200A-CVIV instrument are:</p> <ul style="list-style-type: none"> • All CV channels to C-V 2-wire: <code>KI_CVIV_CVU_2WIRE</code> or 1 • All CV channels to C-V 4-wire: <code>KI_CVIV_CVU_4WIRE</code> or 0

Details

The 4200A-CVIV includes input connections for four 4200-SMU or 4210-SMU cards and one 4210-CVU. Use this command to control switching inside the 4200A-CVIV to connect the SMU and CVU instruments to the output terminals.

The 4200A-CVIV connections are cleared by the `clrcon` command.

Example

```
cviv_config(CVIV1, 1, KI_CVIV_SMU);
```

This command connects channel 1 of the CVIV to a SMU.

Also see

`clrcon`

[cviv_display_config](#) (on page 4-28)

[cviv_display_power](#) (on page 4-29)

cviv_display_config

This command configures the LCD display on the 4200A-CVIV Multi-Switch.

Usage

```
int cviv_display_config(int instr_id, int channel, int identifier, char *value);
```

<i>instr_id</i>	The instrument identification code of the 4200A-CVIV: CVIV1
<i>channel</i>	4200A-CVIV channel (use to set a terminal name): 1 to 4 4200A-CVIV virtual channel (use to set the test name): 5 See Details
<i>identifier</i>	Display the name of the terminal: KI_CVIV_TERMINAL_NAME or 1 Display the name of the test: KI_CVIV_TEST_NAME or 0 See Details
<i>value</i>	A string that defines the name (up to 16 characters for a test name or 6 characters for a terminal name)

Details

Sets the name for the channel terminal or test that is displayed on the 4200A-CVIV for the selected channel.

The *channel* and *identifier* settings must be set for either terminal or test name. For example, if *channel* is set to 2, *identifier* must be set to KI_CVIV_TERMINAL_NAME.

If the `clrcon` command is sent, the 4200A-CVIV display is updated to show the change in connections. If the 4200A-CVIV display is turned off, it remains off after a `clrcon`.

Example

```
cviv_display_config(CVIV1, 2, KI_CVIV_TERMINAL_NAME, "Source");
```

This command sets the name of the channel 2 terminal on the 4200A-CVIV display.

Also see

`clrcon`
[cviv_config](#) (on page 4-27)
[cviv_display_power](#) (on page 4-29)

cviv_display_power

This command sets the display state of the LCD display on the 4200A-CVIV.

Usage

```
int cviv_display_power(int instr_id, int state);
```

<i>instr_id</i>	The instrument identification code of the 4200A-CVIV: CVIV1
<i>state</i>	Display on: KI_CVIV_DISPLAY_ON or 1 Display off: KI_CVIV_DISPLAY_OFF or 0

Details

This command turns the display of the 4200A-CVIV on or off.

When the display is turned off, the 4200A-CVIV clears the displays. A small green circle is displayed to indicate that the 4200A-CVIV instrument is powered.

When the display is turned on, the latest configuration is displayed.

If the `clrcon` command is sent, the 4200A-CVIV display is updated to show the change in connections. If the 4200A-CVIV display is turned off, it remains off after a `clrcon`.

Example

```
cviv_display_power(CVIV1, KI_CVIV_DISPLAY_OFF);  
Turns off the 4200A-CVIV display.
```

Also see

[cviv_config](#) (on page 4-27)

[cviv_display_config](#) (on page 4-28)

Typical applications

In this section:

Introduction	5-1
I-V characterization on a 2-terminal device	5-1
C-V characterization on a 2-terminal device.....	5-3
I-V characterization on a 3-terminal device	5-5
C-V characterization on a 3-terminal device.....	5-7
I-V characterization on a 4-terminal device	5-9
C-V characterization on a 4-terminal device.....	5-11

Introduction

This section provides several simplified connection and switch configuration diagrams to connect the 4200A-CVIV and a device under test (DUT).

I-V characterization on a 2-terminal device

You need two SMUs to perform I-V characterization of a 2-terminal device. The SMUs can be installed in any channel of the 4200A-CVIV, but they are in channel 1 and 2 in this example. Using the `cviv-configure` action in Clarius⁺, configure the 4200A-CVIV to the following settings:

- Ch1Mode: Set Channel 1 to SMU
- Ch2Mode: Set Channel 2 to SMU
- Ch3Mode: Set Channel 3 to Open
- Ch4Mode: Set Channel 4 to Open

Figure 37: Configuration settings for I-V characterization on a 2-terminal device

CV-IV Multi-Switch Channel Config	
Ch1Mode	SMU
Ch2Mode	SMU
Ch3Mode	Open
Ch4Mode	Open

If using 2-wire sense, connect a single triaxial cable to the force output connectors of channels 1 and 2 of the 4200A-CVIV to the device under test. If using 4-wire sense, connect two triaxial cables to the force and sense output connectors of each channel and terminate them together at the device under test. See the next figure for an example of the internal switch configurations and device connections.

Figure 38: 4200A-CVIV connections to a 2-terminal device for I-V characterization

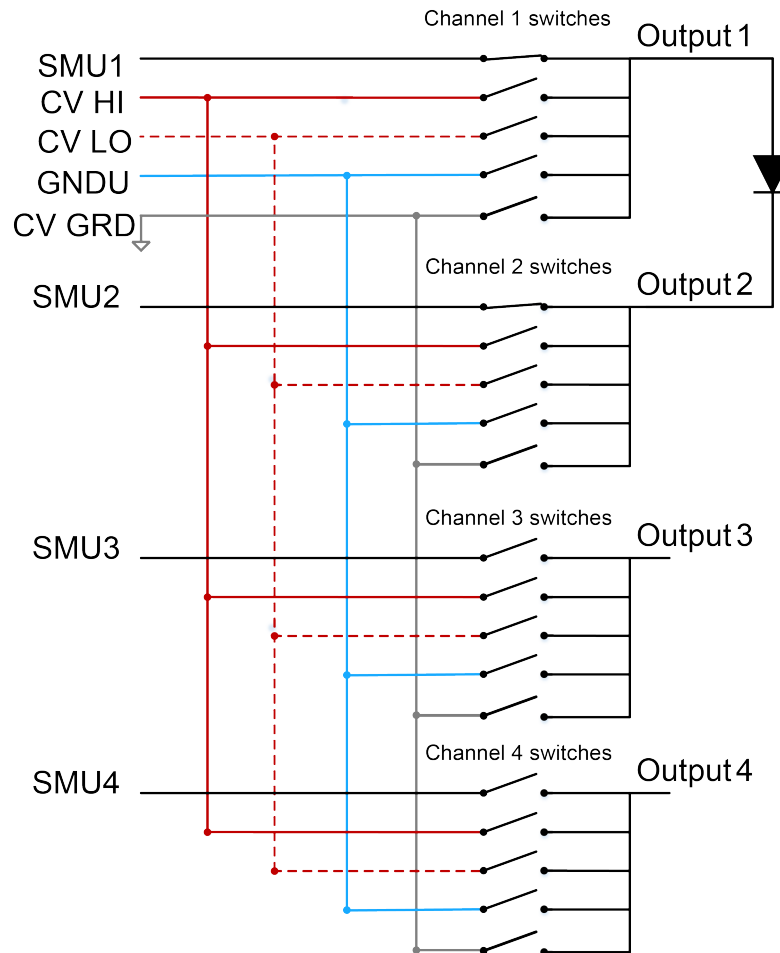

C-V characterization on a 2-terminal device

Only the 4210-CVU is necessary for C-V measurements through the 4200A-CVIV. The 2-terminal device can be connected to any two terminals on the 4200A-CVIV, but channel 1 and channel 2 are used in this example. Using the `cviv-configure` action in Clarius+, configure the 4200A-CVIV to the following settings:

- Ch1Mode: Set Channel 1 to CV HI
- Ch2Mode: Set Channel 2 to CV LO
- Ch3Mode: Set Channel 3 to Open
- Ch4Mode: Set Channel 4 to Open

Figure 39: Configuration settings for C-V characterization on a 2-terminal device

CV-IV Multi-Switch Channel Config	
Ch1Mode	CV HI
Ch2Mode	CV LO
Ch3Mode	Open
Ch4Mode	Open

If using 2-wire sense, connect a single triaxial cable to the force output connector of channels 1 and 2 of the 4200A-CVIV to the device under test. If using 4-wire sense, connect two triaxial cables to the force and sense output connectors of each channel and terminate them together at the device under test. See the next figure for an example of the internal switch configurations and device connections.

Figure 40: 4200A-CVIV connections to a 2-terminal device for C-V characterization

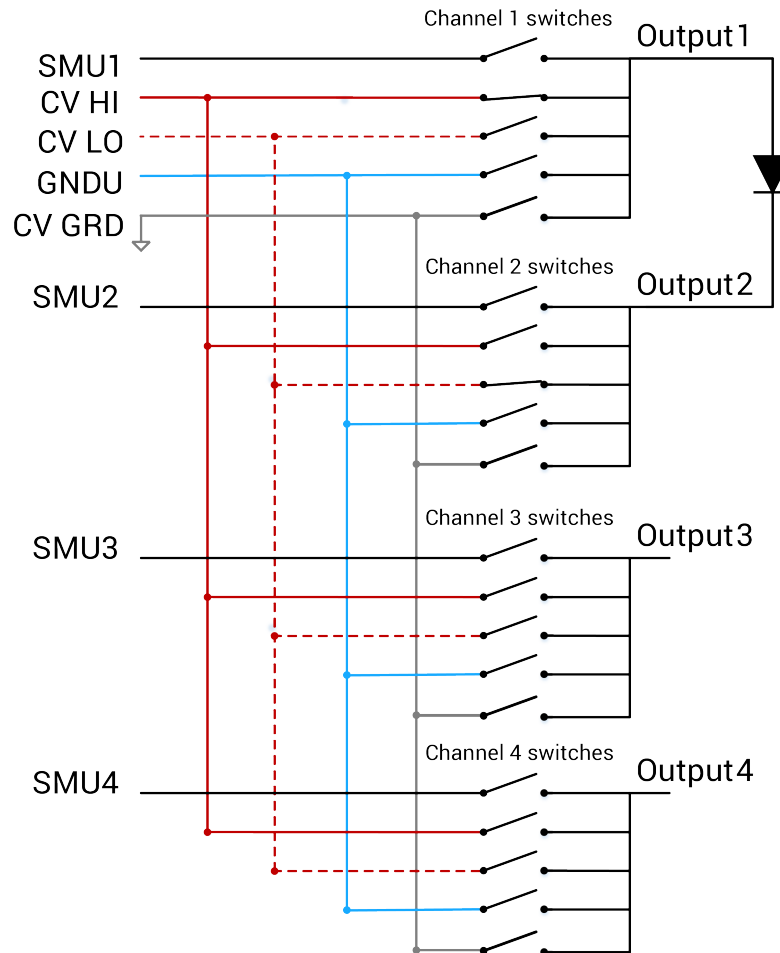

I-V characterization on a 3-terminal device

Three SMUs are necessary to perform an I-V characterization of a 3-terminal device. The SMUs can be installed in any channel of the 4200A-CVIV, but they are in channels 1, 2 and 3 in this example. Using the `cviv-configure` action in Clarius⁺, configure the 4200A-CVIV to the following settings:

- Ch1Mode: Set Channel 1 to SMU
- Ch2Mode: Set Channel 2 to SMU
- Ch3Mode: Set Channel 3 to SMU
- Ch4Mode: Set Channel 4 to Open

Figure 41: Configuration settings for I-V characterization on a 3-terminal device

CV-IV Multi-Switch Channel Config	
Ch1Mode	SMU
Ch2Mode	SMU
Ch3Mode	SMU
Ch4Mode	Open

If using 2-wire sense, connect a single triaxial cable to the force output connector on channels 1, 2, and 3 of the 4200A-CVIV to the device under test. If using 4-wire sense, connect two triaxial cables to the force and sense output connectors of each channel and terminate them together at the device under test. See the next figure for an example of the internal switch configurations and device connections.

Figure 42: 4200A-CVIV connections to a 3-terminal diode device for I-V characterization

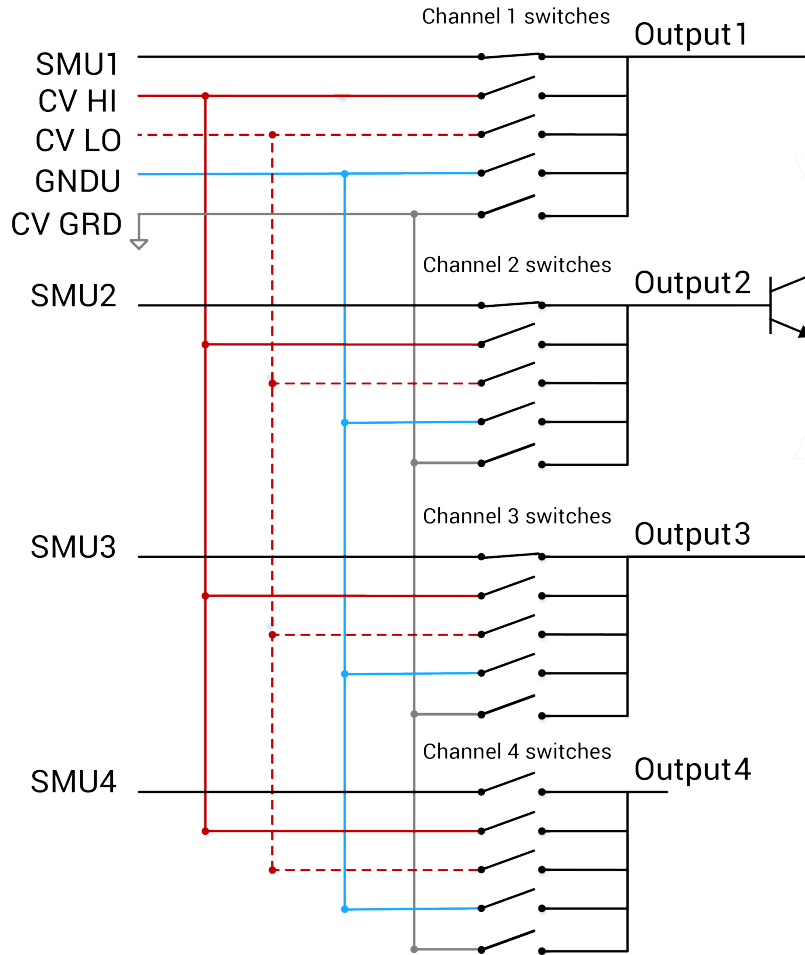

C-V characterization on a 3-terminal device

Only the 4210-CVU is necessary for C-V measurements through the 4200A-CVIV. The 3-terminal device can be connected to any three terminals on the 4200A-CVIV, but channels 1, 2, and 3 are used in this example. This measurement setup demonstrates how to guard a device terminal to be excluded from the measurements. Using the `cviv-configure` action in Clarius+, configure the 4200A-CVIV to the following settings:

- Ch1Mode: Set Channel 1 to CV HI
- Ch2Mode: Set Channel 2 to CV LO
- Ch3Mode: Set Channel 3 to CV Guard
- Ch4Mode: Set Channel 4 to Open

Figure 43: CVIV Multi-switch channel configuration

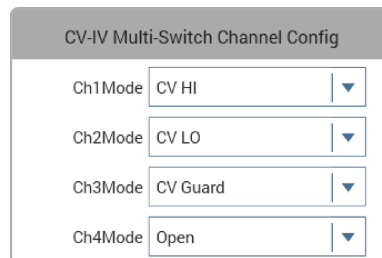

CV-IV Multi-Switch Channel Config	
Ch1Mode	CV HI
Ch2Mode	CV LO
Ch3Mode	CV Guard
Ch4Mode	Open

If using 2-wire sense, connect a single triaxial cable to the force output connectors of channels 1, 2, and 3 of the 4200A-CVIV to the device under test. If using 4-wire sense, connect two triaxial cables to the force and sense output connectors of each channel and terminate them together at the device under test. See the next figure for an example of the internal switch configurations and device connections.

Figure 44: 4200A-CVIV connections to a 3-terminal device for C-V characterization

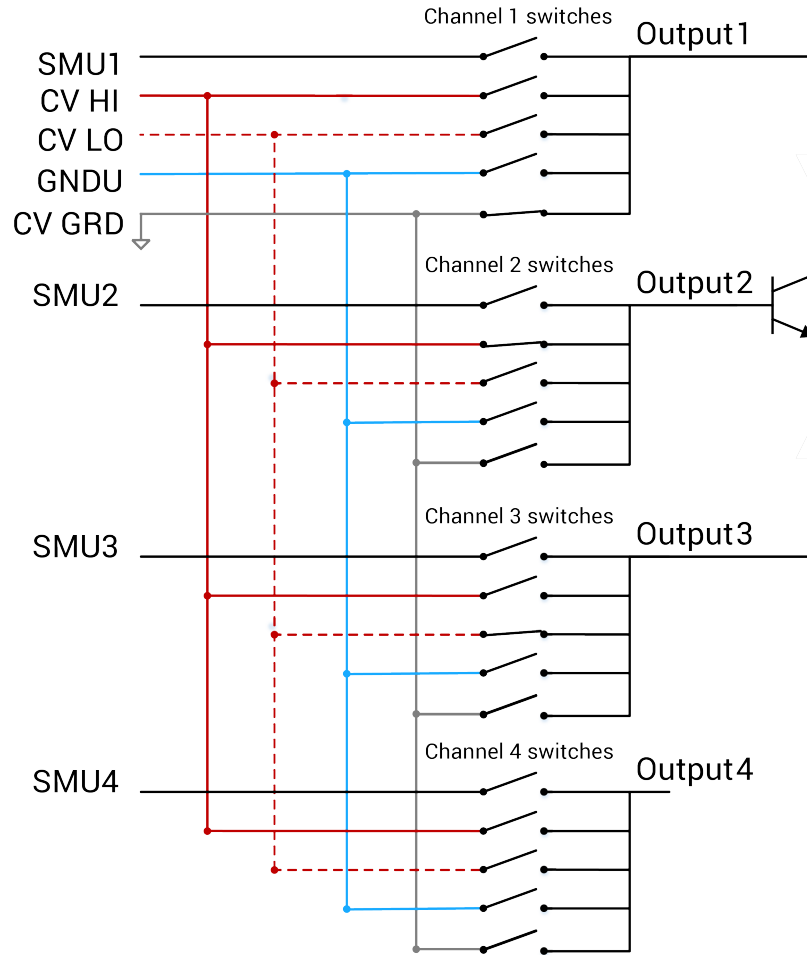

I-V characterization on a 4-terminal device

Four SMUs are necessary to perform an I-V characterization of a 4-terminal device. All four output channels are used in this example. Using the `cviv-configure` action in Clarius+, configure the 4200A-CVIV to the following settings:

- Ch1Mode: Set Channel 1 to SMU
- Ch2Mode: Set Channel 2 to SMU
- Ch3Mode: Set Channel 3 to SMU
- Ch4Mode: Set Channel 4 to SMU

Figure 45: Configuration for I-V settings on a 4-terminal device

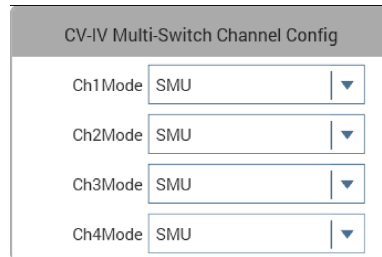

The image shows a configuration window titled "CV-IV Multi-Switch Channel Config". It contains four rows, each representing a channel's mode. Each row has a label (Ch1Mode, Ch2Mode, Ch3Mode, Ch4Mode) followed by a dropdown menu. All four dropdown menus are currently set to "SMU".

Channel	Mode
Ch1Mode	SMU
Ch2Mode	SMU
Ch3Mode	SMU
Ch4Mode	SMU

If your test uses 2-wire sense, connect a single triaxial cable to the force output connector on channels 1, 2, 3, and 4 of the 4200A-CVIV to the device under test. If using 4-wire sense, connect two triaxial cables to the force and sense output connectors of each channel and terminate them together at the device under test. See the next figure for an example of the internal switch configurations and device connections.

Figure 46: 4200A-CVIV connections to a 4-terminal MOSFET device for I-V characterization

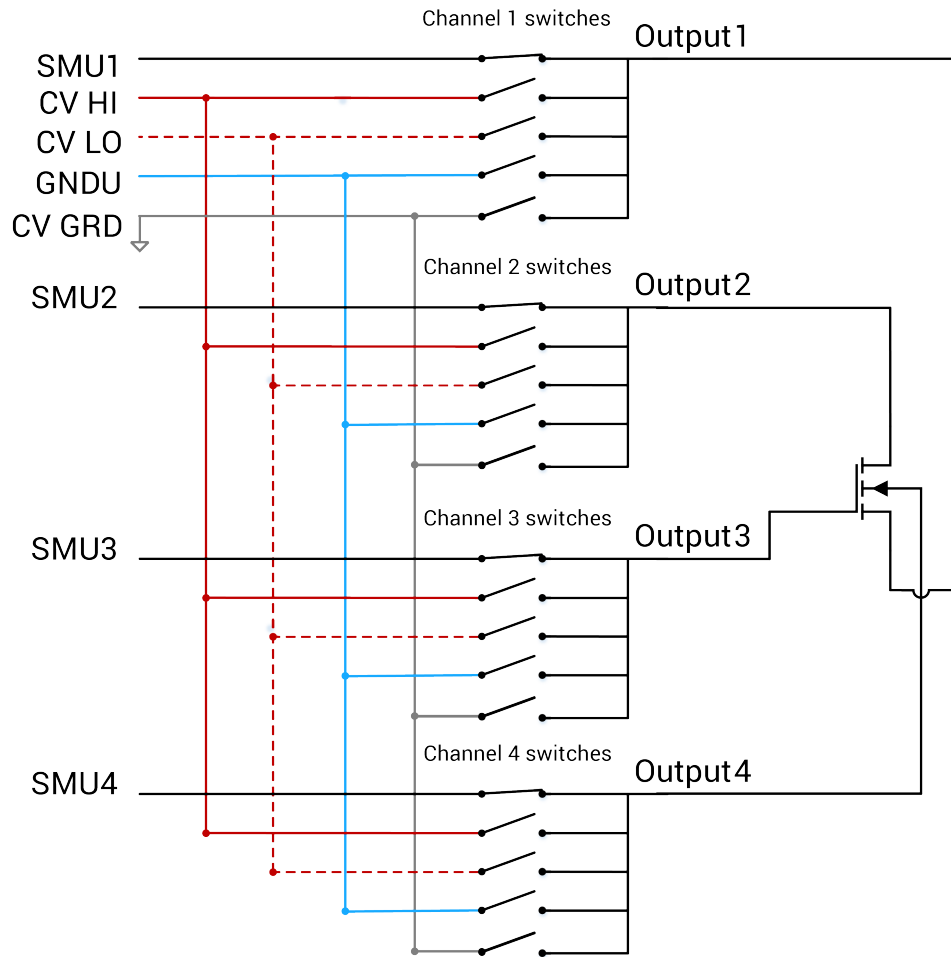

C-V characterization on a 4-terminal device

Only the 4210-CVU is necessary for C-V measurements through the 4200A-CVIV. All four output channels are used in this example. This measurement setup demonstrates how to connect multiple device terminals for a single C-V measurement by assigning them to the same C-V channel. Using the `cviv-configure` action in Clarius⁺, configure the 4200A-CVIV to the following settings:

- Ch1Mode: Set Channel 1 to CV LO
- Ch2Mode: Set Channel 2 to CV LO
- Ch3Mode: Set Channel 3 to CV HI
- Ch4Mode: Set Channel 4 to CV LO

Figure 47: Configuration settings for C-V characterization on a 4-terminal device

CV-IV Multi-Switch Channel Config	
Ch1Mode	CV LO
Ch2Mode	CV LO
Ch3Mode	CV HI
Ch4Mode	CV LO

If using 2-wire sense, connect a single triaxial cable to the force output connector on channels 1, 2, 3, and 4 of the 4200A-CVIV to the device under test. If using 4-wire sense, connect two triaxial cables to the force and sense output connectors of each channel and terminate them together at the device under test. See the next figure for an example of the internal switch configurations and device connections.

Figure 48: 4200A-CVIV connections to a 4-terminal MOSFET device for C-V characterization

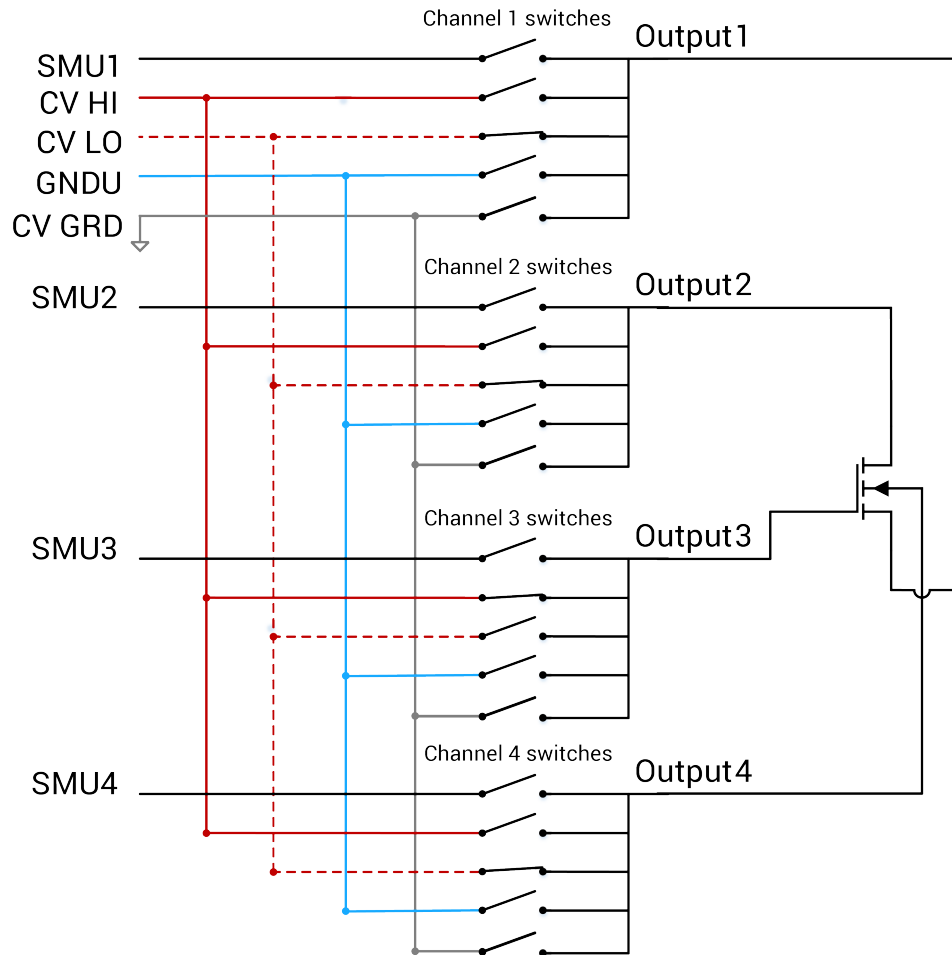

Maintenance

In this section:

Introduction	6-1
Cleaning the display	6-1
Upgrade the instrument firmware	6-2

Introduction

The information in this section describes routine maintenance of the 4200A-CVIV instrument.

Cleaning the display

If you need to clean the front-panel LCD touchscreen display, use a soft dry cloth.

CAUTION

Do not use liquids to clean the display.

Upgrade the instrument firmware

Keithley Instruments releases periodic firmware updates for your 4200A-CVIV. These upgrades are included with each new software build of the Clarius+ application. To upgrade the firmware, you run the **Firmware Upgrade** application on your 4200A-SCS Parameter Analyzer.

To upgrade the instrument firmware:

1. Make sure that the 4200A-CVIV is powered on and connected to the 4200A-SCS Parameter Analyzer with the included USB cable.
2. From the Windows Start menu, enter **FWUpgrade** in the search box. The results display the Keithley Instruments Firmware Upgrade application.
3. Press <Enter> to open the application. A list of installed instruments is displayed.
4. Select **Upgrade** from the bottom of the **Firmware Upgrade** screen to begin.

NOTE

If the Clarius+ software build includes updates for other 4200A-SCS instruments, such as SMU cards, those instruments will also be updated when you run the **Firmware Upgrade** application.

A progress bar is displayed as the firmware is upgraded. When the upgrade is complete, a PASS or FAIL result is displayed next to your 4200A-CVIV in the list of instruments.

Figure 49: 4200A-CVIV firmware upgrade screen

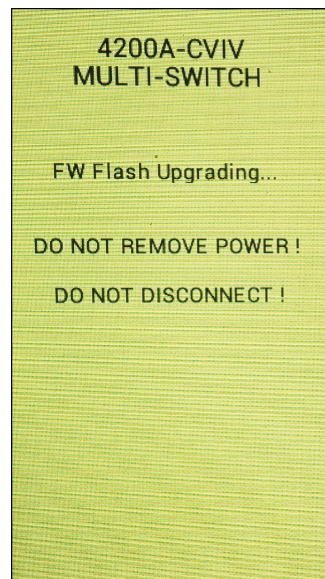

CAUTION

Do not remove instrument power or disconnect any cables from the 4200A-CVIV during the firmware upgrade.

Specifications are subject to change without notice.
All Keithley trademarks and trade names are the property of Keithley Instruments.
All other trademarks and trade names are the property of their respective companies.

Keithley Instruments
Corporate Headquarters • 28775 Aurora Road • Cleveland, Ohio 44139 • 440-248-0400 • Fax: 440-248-6168 • 1-800-935-5595 • www.tek.com/keithley

