Instruction Manual

Models 7013-S and 7013-C

20-channel Relay Switch Cards

Contains Operating and Servicing Information

KEITHLEY

WARRANTY

Keithley Instruments, Inc. warrants this product to be free from defects in material and workmanship for a period of 1 year from date of shipment.

Keithley Instruments, Inc. warrants the following items for 90 days from the date of shipment: probes, cables, rechargeable batteries, diskettes, and documentation.

During the warranty period, we will, at our option, either repair or replace any product that proves to be defective.

To exercise this warranty, write or call your local Keithley representative, or contact Keithley headquarters in Cleveland, Ohio. You will be given prompt assistance and return instructions. Send the product, transportation prepaid, to the indicated service facility. Repairs will be made and the product returned, transportation prepaid. Repaired or replaced products are warranted for the balance of the original warranty period, or at least 90 days.

LIMITATION OF WARRANTY

This warranty does not apply to defects resulting from product modification without Keithley's express written consent, or misuse of any product or part. This warranty also does not apply to fuses, software, non-rechargeable batteries, damage from battery leakage, or problems arising from normal wear or failure to follow instructions.

THIS WARRANTY IS IN LIEU OF ALL OTHER WARRANTIES, EXPRESSED OR IMPLIED, INCLUDING ANY IMPLIED WARRANTY OF MERCHANTABILITY OR FITNESS FOR A PARTICULAR USE. THE REMEDIES PROVIDED HEREIN ARE BUYER'S SOLE AND EXCLUSIVE REMEDIES.

NEITHER KEITHLEY INSTRUMENTS, INC. NOR ANY OF ITS EMPLOYEES SHALL BE LIABLE FOR ANY DIRECT, INDIRECT, SPECIAL, INCIDENTAL OR CONSEQUENTIAL DAMAGES ARISING OUT OF THE USE OF ITS INSTRUMENTS AND SOFTWARE EVEN IF KEITHLEY INSTRUMENTS, INC., HAS BEEN ADVISED IN ADVANCE OF THE POSSIBILITY OF SUCH DAMAGES. SUCH EXCLUDED DAMAGES SHALL INCLUDE, BUT ARE NOT LIMITED TO: COSTS OF REMOVAL AND INSTALLATION, LOSSES SUSTAINED AS THE RESULT OF INJURY TO ANY PERSON, OR DAMAGE TO PROPERTY.

KEITHLEY

Keithley Instruments, Inc. • 28775 Aurora Road • Cleveland, OH 44139 • 440-248-0400 • Fax: 440-248-6168 • <http://www.keithley.com>

CHINA: Keithley Instruments China • Yuan Chen Xin Building, Room 705 • 12 Yumin Road, Dewai, Madian • Beijing 100029 • 8610-62022886 • Fax: 8610-62022892
FRANCE: Keithley Instruments SARL • BP 60 • 3 Allée des Garays • 91122 Palaiseau Cédex • 33-1-60-11-51-55 • Fax: 33-1-60-11-77-26
GERMANY: Keithley Instruments GmbH • Landsberger Strasse 65 • D-82110 Germering, Munich • 49-89-8493070 • Fax: 49-89-84930759
GREAT BRITAIN: Keithley Instruments, Ltd. • The Minster • 58 Portman Road • Reading, Berkshire, England RG3 1EA • 44-1189-596469 • Fax: 44-1189-575666
ITALY: Keithley Instruments SRL • Viale S. Gimignano 38 • 20146 Milano • 39-2-48303008 • Fax: 39-2-48302274
NETHERLANDS: Keithley Instruments BV • Avelingen West 49 • 4202 MS Gorinchem • 31-(0)183-635333 • Fax: 31-(0)183-630821
SWITZERLAND: Keithley Instruments SA • Kriesbachstrasse 4 • 8600 Dübendorf • 41-1-8219444 • Fax: 41-1-8203081
TAIWAN: Keithley Instruments Taiwan • 1FL., 85 Po Ai Street • Hsinchu, Taiwan • 886-3-572-9077 • Fax: 886-3-572-9031

Models 7013-S and 7013-C Instruction Manual

©1991, Keithley Instruments, Inc.
All Rights Reserved
Cleveland, Ohio, U.S.A.
Second Printing, September 1998
Document Number 7013-901-01 Rev. B

Manual Printing History

The printing history shown below lists the printing dates of all Revisions and Addenda created for this manual. The Revision Level letter increases alphabetically as the manual undergoes subsequent updates. Addenda, which are released between Revisions, contain important change information which the user should incorporate immediately into the manual. Addenda are numbered sequentially. When a new Revision is created, all Addenda associated with the previous Revision of the manual are incorporated into the new Revision of the manual. Each new Revision includes a revised copy of this printing history page.

| | |
|--|----------------|
| Revision A (Document Number 7013-901-01) | November 1991 |
| Addendum A (Document Number 7013-901-02) | January 1992 |
| Revision B (Document Number 7013-901-01) | September 1998 |

Safety Precautions

The following safety precautions should be observed before using this product and any associated instrumentation. Although some instruments and accessories would normally be used with non-hazardous voltages, there are situations where hazardous conditions may be present.

This product is intended for use by qualified personnel who recognize shock hazards and are familiar with the safety precautions required to avoid possible injury. Read the operating information carefully before using the product.

The types of product users are:

Responsible body is the individual or group responsible for the use and maintenance of equipment, and for ensuring that operators are adequately trained.

Operators use the product for its intended function. They must be trained in electrical safety procedures and proper use of the instrument. They must be protected from electric shock and contact with hazardous live circuits.

Maintenance personnel perform routine procedures on the product to keep it operating, for example, setting the line voltage or replacing consumable materials. Maintenance procedures are described in the manual. The procedures explicitly state if the operator may perform them. Otherwise, they should be performed only by service personnel.

Service personnel are trained to work on live circuits, and perform safe installations and repairs of products. Only properly trained service personnel may perform installation and service procedures.

Exercise extreme caution when a shock hazard is present. Lethal voltage may be present on cable connector jacks or test fixtures. The American National Standards Institute (ANSI) states that a shock hazard exists when voltage levels greater than 30V RMS, 42.4V peak, or 60VDC are present. **A good safety practice is to expect that hazardous voltage is present in any unknown circuit before measuring.**

Users of this product must be protected from electric shock at all times. The responsible body must ensure that users are prevented access and/or insulated from every connection point. In some cases, connections must be exposed to potential human contact. Product users in these circumstances must be trained to protect themselves from the risk of electric shock. If the circuit is capable of operating at or above 1000 volts, **no conductive part of the circuit may be exposed.**

As described in the International Electrotechnical Commission (IEC) Standard IEC 664, digital multimeter measuring circuits (e.g., Keithley Models 175A, 199, 2000, 2001, 2002, and 2010) are Installation Category II. All other instruments' signal terminals are Installation Category I and must not be connected to mains.

Do not connect switching cards directly to unlimited power circuits. They are intended to be used with impedance limited sources. NEVER connect switching cards directly to AC mains. When connecting sources to switching cards, install protective devices to limit fault current and voltage to the card.

Before operating an instrument, make sure the line cord is connected to a properly grounded power receptacle. Inspect the connecting cables, test leads, and jumpers for possible wear, cracks, or breaks before each use.

For maximum safety, do not touch the product, test cables, or any other instruments while power is applied to the circuit under test. ALWAYS remove power from the entire test system and discharge any capacitors before: connecting or disconnecting cables or jumpers, installing or removing switching cards, or making internal changes, such as installing or removing jumpers.

Do not touch any object that could provide a current path to the common side of the circuit under test or power line (earth) ground. Always make measurements with dry hands while standing on a dry, insulated surface capable of withstanding the voltage being measured.

Do not exceed the maximum signal levels of the instruments and accessories, as defined in the specifications and operating information, and as shown on the instrument or test fixture panels, or switching card.

When fuses are used in a product, replace with same type and rating for continued protection against fire hazard.

Chassis connections must only be used as shield connections for measuring circuits, NOT as safety earth ground connections.

If you are using a test fixture, keep the lid closed while power is applied to the device under test. Safe operation requires the use of a lid interlock.

If a  screw is present, connect it to safety earth ground using the wire recommended in the user documentation.

The  symbol on an instrument indicates that the user should refer to the operating instructions located in the manual.

The  symbol on an instrument shows that it can source or measure 1000 volts or more, including the combined effect of normal and common mode voltages. Use standard safety precautions to avoid personal contact with these voltages.

The **WARNING** heading in a manual explains dangers that might result in personal injury or death. Always read the associated information very carefully before performing the indicated procedure.

The **CAUTION** heading in a manual explains hazards that could damage the instrument. Such damage may invalidate the warranty.

Instrumentation and accessories shall not be connected to humans.

Before performing any maintenance, disconnect the line cord and all test cables.

To maintain protection from electric shock and fire, replacement components in mains circuits, including the power transformer, test leads, and input jacks, must be purchased from Keithley Instruments. Standard fuses, with applicable national safety approvals, may be used if the rating and type are the same. Other components that are not safety related may be purchased from other suppliers as long as they are equivalent to the original component. (Note that selected parts should be purchased only through Keithley Instruments to maintain accuracy and functionality of the product.) If you are unsure about the applicability of a replacement component, call a Keithley Instruments office for information.

To clean the instrument, use a damp cloth or mild, water based cleaner. Clean the exterior of the instrument only. Do not apply cleaner directly to the instrument or allow liquids to enter or spill on the instrument.

7013-C and 7013-S 20-Channel Relay Switch Cards Specifications

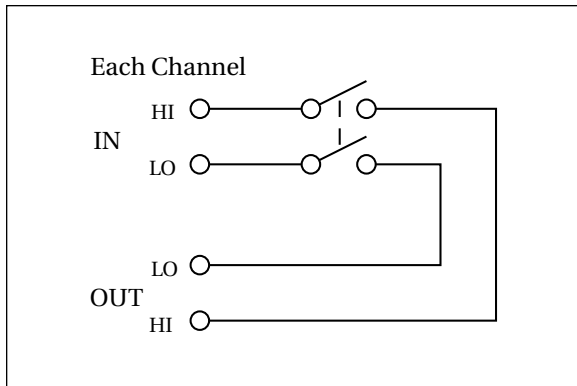

RELAY SWITCH CONFIGURATION: 20 independent channels of 2-pole switching.

CONTACT CONFIGURATION: 2-pole Form A (Hi, Lo).

CONNECTOR TYPE:

7013-C: 96-pin male DIN connector.

7013-S: Screw terminal, #16AWG maximum wire size, with .092 inch O.D. 28 conductors per card maximum. #22AWG typical wire size with .062 inch O.D. 88 conductors per card maximum.

MAXIMUM SIGNAL LEVEL:

DC Signals: 110V DC between any two pins, 1A switched, 30VA (resistive load).

AC Signals: 125V rms and 175V AC peak, between any two pins, 1A switched, 60VA (resistive load).

COMMON MODE VOLTAGE: 175V peak, any pin to chassis.

CONTACT LIFE: Cold Switching: 10⁸ closures.

At Maximum Signal Levels: 10⁵ closures.

CHANNEL RESISTANCE (per conductor): < 1Ω.

CONTACT POTENTIAL:

7013-C: <1μV per channel contact pair

<3μV typical per single contact.

7013-S: <500nV per channel contact pair

<1.5μV typical per single contact.

OFFSET CURRENT: < 100pA.

ACTUATION TIME: 3ms.

ISOLATION: Channel to Channel: >10¹⁰Ω, <25pF

Differential: >10¹⁰Ω, <50pF

Common Mode: >10¹⁰Ω, <100pF

CROSSTALK (1MHz, 50Ω Load): <-50dB.

INSERTION LOSS (50Ω Source, 50 Load): <0.1dB below 1MHz, <3dB below 10MHz.

RELAY DRIVE CURRENT (per relay): 16mA.

ENVIRONMENT: Operating: 0° to 50°C, up to 35°C <80% RH.

Storage: -25°C to 65°C.

Table of Contents

| | | |
|----------|---|------|
| 1 | General Information | |
| 1.1 | Introduction | 1-1 |
| 1.2 | Features | 1-1 |
| 1.3 | Warranty information | 1-1 |
| 1.4 | Manual addenda | 1-2 |
| 1.5 | Safety symbols and terms | 1-2 |
| 1.6 | Specifications | 1-2 |
| 1.7 | Unpacking and inspection | 1-2 |
| 1.7.1 | Inspection for damage | 1-2 |
| 1.7.2 | Shipping contents | 1-2 |
| 1.7.3 | Instruction manual | 1-3 |
| 1.8 | Repacking for shipment | 1-3 |
| 1.9 | Optional accessories | 1-3 |
| | | |
| 2 | Relay Switching Basics | |
| 2.1 | Introduction | 2-1 |
| 2.2 | Basic switch configuration (DPST) | 2-1 |
| 2.3 | Multiple pole configurations | 2-2 |
| | | |
| 3 | Card Connections and Installation | |
| 3.1 | Introduction | 3-1 |
| 3.2 | Handling precautions | 3-1 |
| 3.3 | Connections | 3-1 |
| 3.3.1 | Screw terminal connector card | 3-2 |
| 3.3.2 | Multi-pin (mass termination) connector card | 3-3 |
| 3.4 | Typical connection schemes | 3-8 |
| 3.4.1 | Connection scheme for Model 7013-C | 3-8 |
| 3.4.2 | Connection scheme for Model 7013-S | 3-8 |
| 3.5 | Model 7013 installation and removal | 3-11 |
| | | |
| 4 | Operation | |
| 4.1 | Introduction | 4-1 |
| 4.2 | Power limits | 4-1 |
| 4.2.1 | Maximum signal levels | 4-1 |
| 4.2.2 | Reactive loads | 4-1 |

| | | |
|-------|--|------|
| 4.3 | Mainframe control of relay card | 4-3 |
| 4.3.1 | Channel assignments | 4-3 |
| 4.3.2 | Front panel control | 4-5 |
| 4.3.3 | IEEE-488 bus operation | 4-5 |
| 4.4 | Relay switching examples | 4-6 |
| 4.4.1 | Controlling sources, supplies and loads | 4-6 |
| 4.4.2 | Activating external devices and circuits | 4-8 |
| 4.4.3 | Switching loads | 4-9 |
| 4.5 | Measurement considerations | 4-10 |
| 4.5.1 | Path isolation | 4-10 |
| 4.5.2 | Magnetic fields | 4-11 |
| 4.5.3 | Radio frequency interference | 4-11 |
| 4.5.4 | Ground loops | 4-11 |
| 4.5.5 | Keeping connectors clean | 4-12 |
| 4.5.6 | AC frequency response | 4-12 |

5 Service Information

| | | |
|-------|--|------|
| 5.1 | Introduction | 5-1 |
| 5.2 | Handling and cleaning precautions | 5-1 |
| 5.3 | Performance verification | 5-2 |
| 5.3.1 | Environmental conditions | 5-2 |
| 5.3.2 | Recommended equipment | 5-2 |
| 5.3.3 | Switch card connections | 5-3 |
| 5.3.4 | Channel resistance tests | 5-3 |
| 5.3.5 | Offset current tests | 5-5 |
| 5.3.6 | Contact potential tests | 5-5 |
| 5.3.7 | Channel to channel isolation tests | 5-7 |
| 5.3.8 | Differential isolation tests | 5-10 |
| 5.3.9 | Common-mode isolation tests | 5-11 |
| 5.4 | Special handling of static-sensitive devices | 5-12 |
| 5.5 | Principles of operation | 5-12 |
| 5.5.1 | Block diagram | 5-12 |
| 5.5.2 | ID data circuits | 5-12 |
| 5.5.3 | Relay control | 5-12 |
| 5.5.4 | Relay power control | 5-14 |
| 5.5.5 | Power-on safeguard | 5-14 |
| 5.6 | Troubleshooting | 5-15 |
| 5.6.1 | Troubleshooting equipment | 5-15 |
| 5.6.2 | Troubleshooting access | 5-15 |
| 5.6.3 | Troubleshooting procedure | 5-15 |

6 Replaceable Parts

| | | |
|-----|--|-----|
| 6.1 | Introduction | 6-1 |
| 6.2 | Parts lists | 6-1 |
| 6.3 | Ordering information | 6-1 |
| 6.4 | Factory service | 6-1 |
| 6.5 | Component layouts and schematic diagrams | 6-2 |

List of Illustrations

2 Relay Switching Basics

| | | |
|------------|--|-----|
| Figure 2-1 | Model 7013 20-channel switch card (simplified schematic) | 2-1 |
| Figure 2-2 | 4PST configuration using card pair | 2-2 |

3 Card Connections and Installation

| | | |
|-------------|--|------|
| Figure 3-1 | Screw terminal connector card | 3-2 |
| Figure 3-2 | Typical terminal block connections | 3-3 |
| Figure 3-3 | Cable clamp for screw terminal connector card | 3-3 |
| Figure 3-4 | Multi-pin connector card terminal identification | 3-4 |
| Figure 3-5 | Typical round cable connection techniques | 3-6 |
| Figure 3-6 | Model 7011-MTR connector pinout | 3-7 |
| Figure 3-7 | Model 7011-KIT-R (cable) assembly | 3-7 |
| Figure 3-8 | Typical connection scheme for Model 7013-C | 3-9 |
| Figure 3-9 | Typical connection scheme for Model 7013-S | 3-10 |
| Figure 3-10 | Model 7013-S card installation in Model 7001 | 3-12 |
| Figure 3-11 | Model 7013-C card installation in Model 7001 | 3-13 |

4 Operation

| | | |
|-------------|---|------|
| Figure 4-1 | Limiting inductive reaction voltage | 4-2 |
| Figure 4-2 | Limiting capacitive reaction current | 4-2 |
| Figure 4-3 | Channel status display (two Model 7013 cards installed) | 4-3 |
| Figure 4-4 | Display organization for relay card channels | 4-4 |
| Figure 4-5 | Channel assignments | 4-4 |
| Figure 4-6 | Controlling sources, supplies and loads | 4-7 |
| Figure 4-7 | Controlling external devices and circuits | 4-8 |
| Figure 4-8 | Switching loads | 4-9 |
| Figure 4-9 | Path isolation resistance | 4-10 |
| Figure 4-10 | Voltage attenuation by path isolation resistance | 4-10 |
| Figure 4-11 | Power line ground loops | 4-12 |
| Figure 4-12 | Eliminating ground loops | 4-12 |

5

Service Information

| | | |
|------------|---|------|
| Figure 5-1 | Channel resistance testing | 5-4 |
| Figure 5-2 | Offset current testing | 5-6 |
| Figure 5-3 | Contact potential testing | 5-7 |
| Figure 5-4 | Channel to channel testing | 5-8 |
| Figure 5-5 | Differential isolation testing | 5-10 |
| Figure 5-6 | Common-mode isolation testing | 5-11 |
| Figure 5-7 | Model 7013 block diagram | 5-13 |
| Figure 5-8 | Start and stop sequences | 5-13 |
| Figure 5-9 | Transmit and acknowledge sequence | 5-14 |

List of Tables

3 Card Connections and Installation

| | | |
|-----------|------------------------------------|-----|
| Table 3-1 | Mass termination accessories | 3-3 |
|-----------|------------------------------------|-----|

5 Service Information

| | | |
|-----------|---|------|
| Table 5-1 | Verification equipment | 5-2 |
| Table 5-2 | Channel to channel isolation tests | 5-9 |
| Table 5-3 | Recommended troubleshooting equipment | 5-15 |
| Table 5-4 | Troubleshooting procedure | 5-16 |

6 Replaceable Parts

| | | |
|-----------|---|-----|
| Table 6-1 | Relay board for Model 7013-S and 7013-C, parts list | 6-3 |
| Table 6-2 | Screw terminal board for Model 7013-S, parts list | 6-4 |
| Table 6-3 | Mass terminated board for Model 7013-C, parts list | 6-4 |

General Information

1.1 Introduction

This section contains general information about the Model 7013 20-Channel Relay card.

There are two basic versions of this relay switch card; the Model 7013-S and the Model 7013-C. The Model 7013-S assembly consists of a screw terminal connector card and the relay card. External test circuits are wired directly to the screw terminals of the connector card. Also available from Keithley is the Model 7013-ST. This is an extra screw terminal connector card. With an extra connector card, you can wire a second test system without disturbing the wiring configuration of the first test system.

The Model 7013-C assembly consists of a multi-pin (mass termination) connector card and the relay card. External test circuit connections to the 7013 are made via the 96-pin male DIN connector on the connector card. Keithley offers a variety of optional accessories that can be used to make connections to the connector card (see paragraph 1.9).

The rest of Section 1 is arranged in the following manner:

1.2 Features

1.3 Warranty information

1.4 Manual addenda

1.5 Safety symbols and terms

1.6 Specifications

1.7 Unpacking and inspection

1.8 Repacking for shipment

1.9 Optional accessories

1.2 Features

The Model 7013 is a general purpose, 20-channel relay switch card. Some of the key features include:

- Low contact potential and offset current for minimal effects on low-level signals.
- The connector board detaches from the relay board. This allows easy access to the screw terminals of the Model 7013-S.

1.3 Warranty information

Warranty information is located on the inside front cover of this instruction manual. Should your Model 7013 require warranty service, contact the Keithley representative or authorized repair facility in your area for

further information. When returning the card for repair, be sure to fill out and include the service form at the back of this manual in order to provide the repair facility with the necessary information.

1.4 Manual addenda

Any improvements or changes concerning the switch card or manual will be explained in an addendum included with the card. Addenda are provided in a page-replacement format. Simply replace the obsolete pages with the new pages.

1.5 Safety symbols and terms

The following symbols and terms may be found on an instrument or used in this manual.

The  symbol on an instrument indicates that the user should refer to the operating instructions located in the instruction manual.

The  symbol on an instrument shows that high voltage may be present on the terminal(s). Use standard safety precautions to avoid personal contact with these voltages.

The **WARNING** heading used in this manual explains dangers that might result in personal injury or death. Always read the associated information very carefully before performing the indicated procedure.

The **CAUTION** heading used in this manual explains hazards that could damage the switch card. Such damage may invalidate the warranty.

1.6 Specifications

Model 7013 specifications may be found at the front of this manual. These specifications are exclusive of the Model 7001 mainframe specifications.

1.7 Unpacking and inspection

1.7.1 Inspection for damage

The Model 7013 is packaged in a re-sealable, anti-static bag to protect it from damage due to static discharge and from contamination that could degrade its performance. Before removing the card from the bag, observe the following precautions on handling.

Handling precautions:

1. Always grasp the card by the side edges and shields. Do not touch the board surfaces or components.
2. When not installed in a Model 7001 mainframe, keep the card in the anti-static bag and store it in the original packing carton.

After removing the card from its anti-static bag, inspect it for any obvious signs of physical damage. Report any such damage to the shipping agent immediately.

1.7.2 Shipping contents

The following items are included with every Model 7013 order:

- Model 7013 20-channel Relay Switch Card
- Model 7013 Instruction Manual
- Additional accessories as ordered.

1.7.3 Instruction manual

The Model 7013 Instruction Manual is three-hole drilled so that it can be added to the three-ring binder of the Model 7001 Instruction Manual. After removing the plastic wrapping, place the manual in the binder following the mainframe instruction manual. Note that a manual identification tab is included and should precede the switch card instruction manual.

If an additional instruction manual is required, order the manual package, Keithley part number 7013-901-00. The manual package includes an instruction manual and any pertinent addenda

1.8 Repacking for shipment

Should it become necessary to return the Model 7013 for repair, carefully pack the unit in its original packing carton or the equivalent, and include the following information:

- Advise as to the warranty status of the switch card.
- Write ATTENTION REPAIR DEPARTMENT on the shipping label.
- Fill out and include the service form located at the back of this manual.

1.9 Optional accessories

The following accessories are available for use with the Model 7013:

Model 7013-ST — This screw terminal connector card is identical to the one provided with the Model 7013-S assembly. An extra screw terminal connector card allows you to wire a second test system without disturbing the wiring configuration of the first connector card.

Model 7011-KIT-R — This connection kit includes a 96-pin female DIN connector that will mate directly to the connector on the Model 7013-C or to a standard 96-pin male DIN bulkhead connector (see Model 7011-MTR). This connector uses solder cups for connections to external circuitry. It includes an adapter for a round cable and the housing.

Model 7011-MTC-2 — This two-meter round cable assembly is terminated with a 96-pin female DIN connector on each end. It will mate directly to the connector on the Model 7013-C and to a standard 96-pin male DIN bulkhead connector (see Model 7011-MTR).

Model 7011-MTR — This 96-pin male DIN bulkhead connector uses solder cups for connections to external circuitry. It will mate to the Model 7011-KIT-R connector, and Model 7011-MTC-2 cable assembly.

2

Relay Switching Basics

2.1 Introduction

This section covers switching basics and is arranged as follows:

- 2.2 Basic switch configuration** — Covers the basic double-pole single-throw (DPST) switch configuration.
- 2.3 Multiple pole configurations** — Shows how to use two or more relays together for multiple pole switching.

2.2 Basic switch configuration (DPST)

A simplified schematic of the Model 7013 switch card is shown in Figure 2-1. The card consists of 20 independent channels. Each channel is made up of a double-pole single-throw (DPST), normally open (NO) switch.

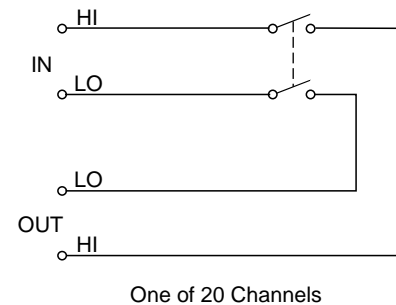

Figure 2-1
Model 7013 20-channel switch card (simplified schematic)

2.3 Multiple pole configurations

Multiple pole configurations are possible by energizing two or more relays at the same time. A four-pole single-throw (4PST) switch system can be configured using two relay channels. Both loads are selected when the two relays are energized. Each additional relay adds two poles to the switch system.

A convenient way to perform multiple-pole switching is to use two Model 7013 switch cards; one installed in Slot 1 of the mainframe and the other installed in Slot 2. By using the Card-Pairing feature of the Model 7001, closing a channel on Card 1 will automatically close the corresponding channel on Card 2. For example, closing channel 1 on Card 1 will automatically close Channel 1 on Card 2 providing 4PST switching, as shown in Figure 2-2.

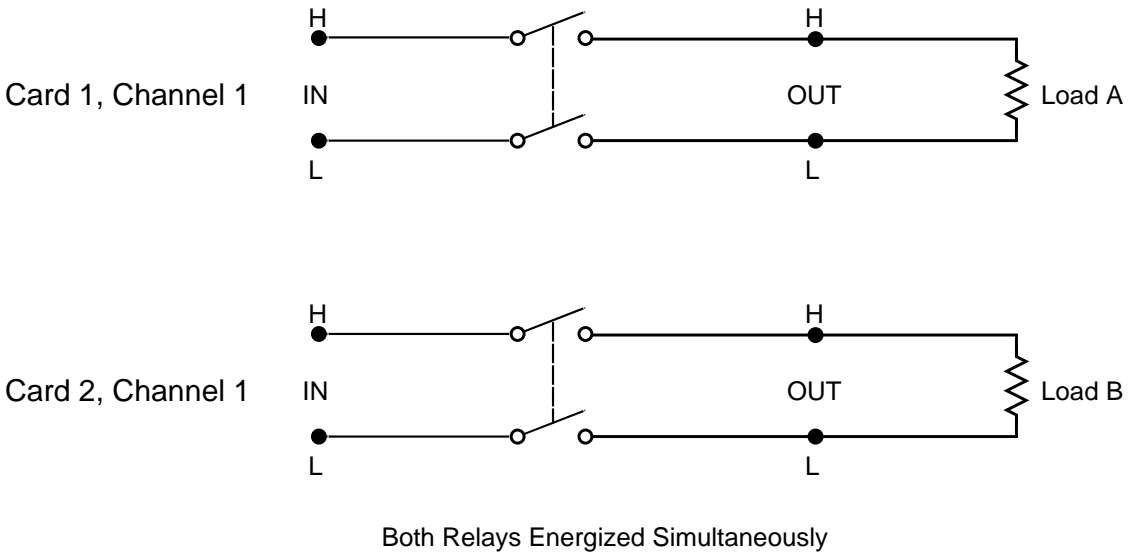

Figure 2-2
4PST configuration using card pair

3

Card Connections and Installation

3.1 Introduction

WARNING

The procedures in this section are intended only for qualified service personnel. Do not perform these procedures unless qualified to do so. Failure to recognize and observe normal safety precautions could result in personal injury or death.

The information in this section is arranged as follows:

- 3.2 Handling precautions** — Explains precautions that must be followed to prevent contamination to the switch card assembly. Contamination could degrade the performance of the switch card.
- 3.3 Connections** — Covers the basics for connecting external circuitry to the two available connector cards; the screw terminal connector card and the multi-pin connector card.
- 3.4 Typical connection schemes** — Provides some typical connection schemes for single card, two-card, and two-mainframe system configurations.
- 3.5 Model 7013 installation and removal** — Provides the procedures to install and remove the switch card assembly in the Model 7001 mainframe.

3.2 Handling precautions

To maintain high impedance isolation, care should be taken when handling the relay card to avoid contamination from such foreign materials as body oils. Such contamination can substantially lower leakage resistances, thus degrading performance.

To avoid possible contamination, always grasp the relay card and the connector card by the side edges or shields. Do not touch the board surfaces or components. On connectors, do not touch areas adjacent to the electrical contacts. Dirt build-up over a period of time is another possible source of contamination. To avoid this problem, operate the mainframe and switch card assembly in a clean environment.

If a card becomes contaminated, it should be thoroughly cleaned as explained in paragraph 5.2.

3.3 Connections

This paragraph provides the basic information needed to connect your external test circuitry to the switch card. It includes detailed information on the two available connector cards.

WARNING

The following connection information is intended to be used by qualified service personnel. Failure to recognize and observe standard safety precautions could result in personal injury or death.

3.3.1 Screw terminal connector card

The screw terminal connector card is shown in Figure 3-1. Connections are made directly to the screw terminals of the 20-terminal blocks. One terminal block is dedicated to each of the 20 channels. Each screw terminal will accommodate #16-22 AWG wire.

Wiring procedure

Perform the following procedure to wire circuitry to the screw terminal connector card:

WARNING

Make sure all power is off and any stored energy in external circuitry is discharged.

1. If mated together, separate the connector card from the relay card by removing the mounting screw and pulling the two cards away from each other. Remember to only handle the cards by the edges and shields to avoid contamination.
2. Using an insulated screwdriver, connect the circuitry to the appropriate terminals. Figure 3-2 shows how connections would be made to deliver power to a DUT (device under test) using Channel 2.
3. Referring to Figure 3-3, remove the top half of the cable clamp as follows:
 - a. Loosen the cable clamp screw enough to disengage it from the bottom half of the cable clamp.
 - b. Using your thumb and forefinger, press the retaining clips inward and, with your other hand, remove the top half of the clamp.

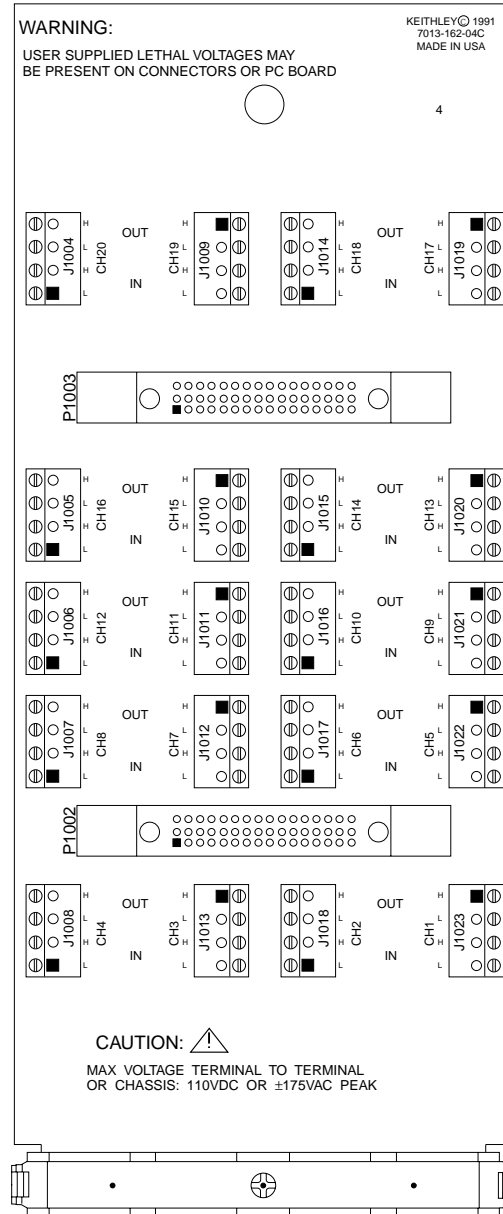

Figure 3-1
Screw terminal connector card

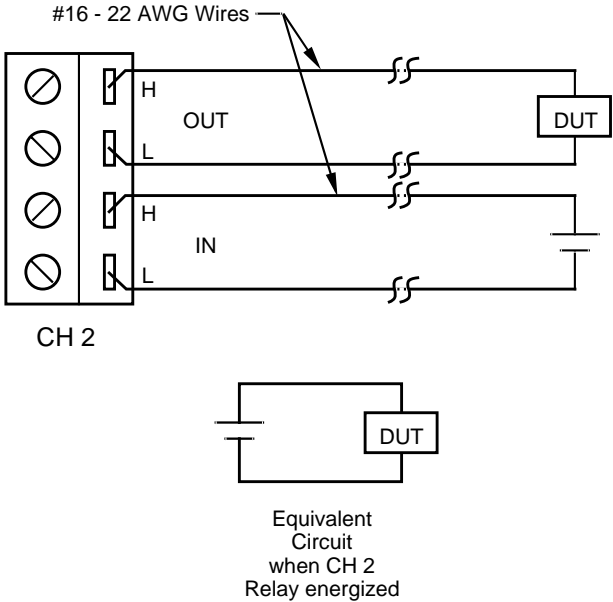

Figure 3-2
Typical terminal block connections

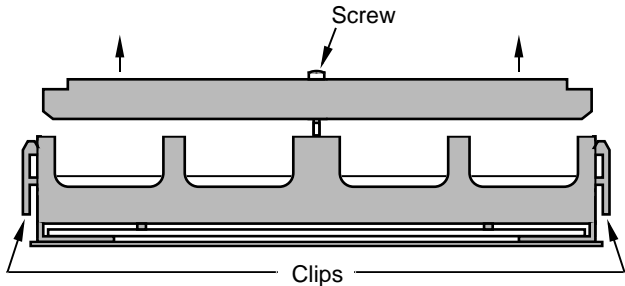

Figure 3-3
Cable clamp for screw terminal connector card

4. Route the wires through the bottom half of the cable clamp.
5. Replace the top half of the clamp. It simply snaps onto the bottom half of the clamp. Tighten the cable clamp screw. The clamp serves as a strain relief for the wires.

6. Mate the connector card to the relay card. The Model 7013 is now ready to be installed in the Model 7001 mainframe. See paragraph 3.5 for details.

3.3.2 Multi-pin (mass termination) connector card

Since connections to external circuitry are made at the 96-pin male DIN bulkhead connector, there is no need to separate the connector card from the relay card. If the connector card is separated from the relay card, carefully mate them together and install the supplied 4-40 screw to secure the cards. Make sure to handle the cards by the edges and shields to avoid contamination.

Terminal identification for the DIN connector of the multi-pin connector card is provided by Figure 3-4. This connector will mate to a 96-pin female DIN connector.

Keithley has a variety of cable and connector accessories available to accommodate connections from the connector card to test instrumentation and DUT (devices under test). In general, these accessories, which are summarized in Table 3-1, utilize a round cable assembly for connections.

Table 3-1
Mass termination accessories

| Model | Description |
|------------|---|
| 7011-KIT-R | 96-pin female DIN connector and housing for round cable. |
| 7011-MTC-2 | Two-meter round cable assembly terminated with a 96-pin female DIN connector on each end. |
| 7011-MTR | 96-pin male DIN bulkhead connector. |

Pins of the Model 7013-C mass termination connector can be identified in one of three ways:

1. Switch channel, 1-20
2. Connector designation, consisting of rows a-c and columns 1-32.
3. Schematic and component layout designation (1-96).

The following pinout diagrams show the correspondence between these arrangements:

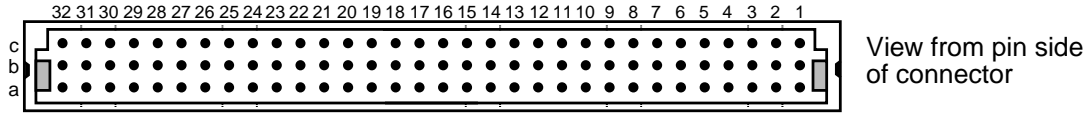

| Switch Terminal | Connector Desig. 1a-32c | Schem. Desig. 1-96 | Switch Terminal | Connector Desig. 1a-32c | Schem. Desig. 1-96 | Switch Terminal | Connector Desig. 1a-32c | Schem. Desig. 1-96 | | |
|-----------------|-------------------------|--------------------|-----------------|-------------------------|--------------------|-----------------|-------------------------|--------------------|--------|-------|
| CH 1 | In HI | 4c | CH 9 | In HI | 16c | CH 17 | In HI | 28c | | |
| | LO | 4b | | LO | 16b | | LO | 28b | | |
| | Out HI | 4a | | Out HI | 16a | | Out HI | 28a | | |
| CH 2 | LO | 3c | CH 10 | LO | 15c | CH 18 | LO | 27c | | |
| | In HI | 6a | | In HI | 18a | | In HI | 30a | | |
| | LO | 5c | | LO | 17c | | LO | 29c | | |
| CH 3 | Out HI | 5b | CH 11 | Out HI | 17b | CH 19 | Out HI | 29b | | |
| | LO | 5a | | LO | 17a | | LO | 29a | | |
| | In HI | 7b | | In HI | 19b | | In HI | 31b | | |
| CH 4 | LO | 7a | CH 12 | LO | 19a | CH 20 | LO | 31a | | |
| | Out HI | 6c | | Out HI | 18c | | Out HI | 30c | | |
| | LO | 6b | | LO | 18b | | LO | 30b | | |
| CH 5 | In HI | 8c | CH 13 | In HI | 20c | CH 20 | In HI | 32c | | |
| | LO | 8b | | LO | 20b | | LO | 32b | | |
| | Out HI | 8a | | Out HI | 20a | | Out HI | 32a | | |
| CH 6 | LO | 7c | CH 14 | LO | 19c | CH 20 | LO | 31c | | |
| | In HI | 10c | | In HI | 22c | | CH 20 | In HI | 32c | |
| | LO | 10b | | LO | 22b | | | LO | 32b | |
| CH 7 | Out HI | 10a | CH 15 | Out HI | 22a | CH 20 | | Out HI | 32a | |
| | LO | 9c | | LO | 21c | | LO | 31c | | |
| | In HI | 12a | | In HI | 24a | | CH 20 | In HI | 32c | |
| CH 8 | LO | 11c | CH 16 | LO | 23c | CH 20 | | LO | 32b | |
| | Out HI | 11b | | Out HI | 23b | | | Out HI | 32a | |
| | LO | 11a | | LO | 23a | | LO | 31c | | |
| CH 9 | In HI | 13b | CH 17 | In HI | 25b | CH 20 | In HI | 32c | | |
| | LO | 13a | | LO | 25a | | LO | 32b | | |
| | Out HI | 12c | | Out HI | 24c | | Out HI | 32a | | |
| CH 10 | LO | 12b | CH 18 | LO | 24b | CH 20 | LO | 31c | | |
| | In HI | 14c | | In HI | 26c | | CH 20 | In HI | 32c | |
| | LO | 14b | | LO | 26b | | | LO | 32b | |
| CH 11 | Out HI | 14a | CH 19 | Out HI | 26a | CH 20 | | Out HI | 32a | |
| | LO | 13c | | LO | 25c | | LO | 31c | | |
| | In HI | 16c | | In HI | 80 | | CH 20 | In HI | 32c | |
| CH 12 | LO | 16b | LO | 48 | CH 20 | LO | | 32b | | |
| | Out HI | 4 | Out HI | 16 | | CH 20 | | Out HI | 32a | |
| | LO | 67 | LO | 79 | | | CH 20 | LO | 31c | |
| CH 13 | In HI | 6 | CH 20 | In HI | 18 | | | CH 20 | In HI | 30a |
| | LO | 69 | | LO | 81 | CH 20 | | | LO | 29c |
| | Out HI | 37 | | Out HI | 49 | | CH 20 | | Out HI | 29b |
| CH 14 | LO | 5 | CH 20 | LO | 17 | | | CH 20 | LO | 29a |
| | In HI | 39 | | CH 20 | In HI | 51 | | | CH 20 | In HI |
| | LO | 7 | | | CH 20 | LO | 19 | | | CH 20 |
| CH 15 | Out HI | 70 | CH 20 | | | Out HI | 82 | CH 20 | | |
| | LO | 38 | | CH 20 | | LO | 50 | | CH 20 | |
| | In HI | 72 | | | CH 20 | In HI | 84 | | | CH 20 |
| CH 16 | LO | 40 | CH 20 | | | LO | 52 | CH 20 | | |
| | Out HI | 8 | | CH 20 | | Out HI | 20 | | CH 20 | |
| | LO | 71 | | | CH 20 | LO | 83 | | | CH 20 |
| CH 17 | In HI | 74 | CH 20 | | | In HI | 86 | CH 20 | | |
| | LO | 42 | | CH 20 | | LO | 54 | | CH 20 | |
| | Out HI | 10 | | | CH 20 | Out HI | 22 | | | CH 20 |
| CH 18 | LO | 73 | CH 20 | | | LO | 85 | CH 20 | | |
| | In HI | 12 | | CH 20 | | In HI | 24 | | CH 20 | |
| | LO | 75 | | | CH 20 | LO | 87 | | | CH 20 |
| CH 19 | Out HI | 43 | CH 20 | | | Out HI | 55 | CH 20 | | |
| | LO | 11 | | CH 20 | | LO | 23 | | CH 20 | |
| | In HI | 45 | | | CH 20 | In HI | 57 | | | CH 20 |
| CH 20 | LO | 13 | CH 20 | | | LO | 25 | CH 20 | | |
| | Out HI | 76 | | CH 20 | | Out HI | 88 | | CH 20 | |
| | LO | 44 | | | CH 20 | LO | 56 | | | CH 20 |
| CH 21 | In HI | 78 | CH 20 | | | In HI | 90 | CH 20 | | |
| | LO | 46 | | CH 20 | | LO | 58 | | CH 20 | |
| | Out HI | 14 | | | CH 20 | Out HI | 26 | | | CH 20 |
| CH 22 | LO | 77 | CH 20 | | | LO | 89 | CH 20 | | |
| | In HI | 16c | | CH 20 | | In HI | 80 | | CH 20 | |
| | LO | 16b | | | CH 20 | LO | 48 | | | CH 20 |
| CH 23 | Out HI | 4 | CH 20 | | | Out HI | 16 | CH 20 | | |
| | LO | 67 | | CH 20 | | LO | 79 | | CH 20 | |
| | In HI | 6 | | | CH 20 | In HI | 18 | | | CH 20 |
| CH 24 | LO | 69 | CH 20 | | | LO | 81 | CH 20 | | |
| | Out HI | 37 | | CH 20 | | Out HI | 49 | | CH 20 | |
| | LO | 5 | | | CH 20 | LO | 17 | | | CH 20 |
| CH 25 | In HI | 39 | CH 20 | | | In HI | 51 | CH 20 | | |
| | LO | 7 | | CH 20 | | LO | 19 | | CH 20 | |
| | Out HI | 70 | | | CH 20 | Out HI | 82 | | | CH 20 |
| CH 26 | LO | 38 | CH 20 | | | LO | 50 | CH 20 | | |
| | In HI | 72 | | CH 20 | | In HI | 84 | | CH 20 | |
| | LO | 40 | | | CH 20 | LO | 52 | | | CH 20 |
| CH 27 | Out HI | 8 | CH 20 | | | Out HI | 20 | CH 20 | | |
| | LO | 71 | | CH 20 | | LO | 83 | | CH 20 | |
| | In HI | 74 | | | CH 20 | In HI | 86 | | | CH 20 |
| CH 28 | LO | 42 | CH 20 | | | LO | 54 | CH 20 | | |
| | Out HI | 10 | | CH 20 | | Out HI | 22 | | CH 20 | |
| | LO | 73 | | | CH 20 | LO | 85 | | | CH 20 |
| CH 29 | In HI | 12 | CH 20 | | | In HI | 24 | CH 20 | | |
| | LO | 75 | | CH 20 | | LO | 87 | | CH 20 | |
| | Out HI | 43 | | | CH 20 | Out HI | 55 | | | CH 20 |
| CH 30 | LO | 11 | CH 20 | | | LO | 23 | CH 20 | | |
| | In HI | 45 | | CH 20 | | In HI | 57 | | CH 20 | |
| | LO | 13 | | | CH 20 | LO | 25 | | | CH 20 |
| CH 31 | Out HI | 76 | CH 20 | | | Out HI | 88 | CH 20 | | |
| | LO | 44 | | CH 20 | | LO | 56 | | CH 20 | |
| | In HI | 78 | | | CH 20 | In HI | 90 | | | CH 20 |
| CH 32 | LO | 46 | CH 20 | | | LO | 58 | CH 20 | | |
| | Out HI | 14 | | CH 20 | | Out HI | 26 | | CH 20 | |
| | LO | 77 | | | CH 20 | LO | 89 | | | CH 20 |

Note: Refer to the schematic for shield pins.

Figure 3-4
Multi-pin connector card terminal identification

Typical connection techniques

All external circuitry, such as instrumentation and DUTs, that you wish to connect to the switch card must be terminated with a single 96-pin female DIN connector. The following connection techniques provide some guidelines and suggestions for wiring your circuitry.

WARNING

Before beginning any wiring procedures, make sure all power is off and stored energy in external circuitry is discharged.

NOTE

It is recommended that external circuitry be connected (plugged in) after the Model 7013 assembly is installed in the Model 7001 mainframe. Installation is covered in paragraph 3.5.

Round cable assemblies — Figure 3-5 shows typical round cable connection techniques using accessories available from Keithley.

In Figure 3-5A, connections are accomplished using a Model 7011-MTC-2 cable and a Model 7011-MTR bulkhead connector. The two-meter round cable is termi-

nated with a 96-pin female DIN connector at each end. This cable mates directly to the multi-pin connector card and to the bulkhead connector. The bulkhead connector has solder cups to allow direct connection to instrumentation and DUT. Figure 3-6 provides pinout for the bulkhead connector. The view shown is from the solder cup end of the connector.

In Figure 3-5B, connections are accomplished using a Model 7011-MTC-2 cable assembly that is cut in half. The 96-pin female DIN connector on one end of the cable mates directly to the multi-pin connector card. The unterminated end of the cable is wired directly to instrumentation and DUT. The other half of the cable assembly could be used for a second switching card.

In Figure 3-5C, connections are accomplished using a custom-built cable assembly that consists of a Model 7011-KIT-R connector and a suitable round cable. Hitachi part number N2807-P/D-50TAB is a round, 50-conductor cable. Two cables can be used to provide 100 conductors. The connector has solder cups to accommodate the individual wires of the unterminated cable. Figure 3-7 provides an exploded view of the connector assembly and shows how the cable is connected. The connector end of the resultant cable assembly mates directly to the multi-pin connector card. The unterminated end of the cable assembly is wired directly to instrumentation and DUT.

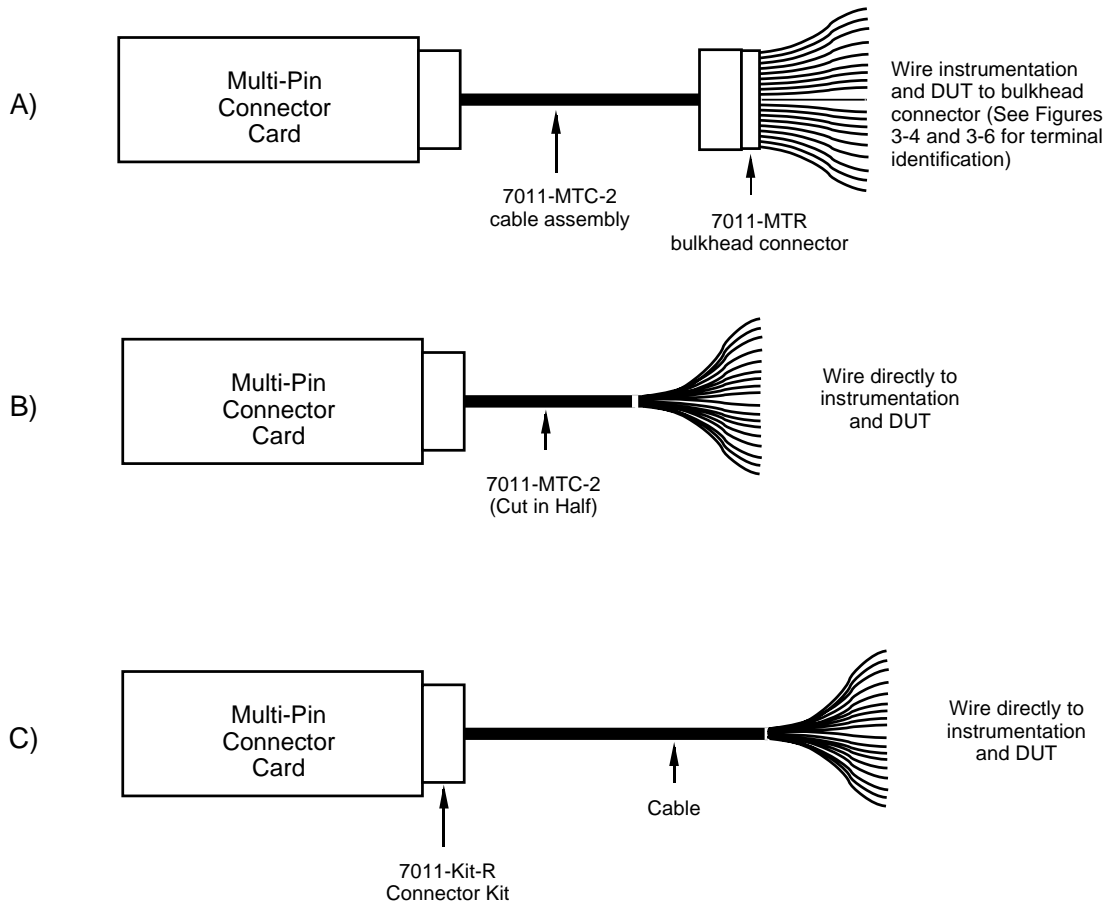

Notes : Figure 3-7 provides an exploded view showing how the connector (with cable) is assembled.

Cable Hitachi p/n N2807-P/D-50TAB is a 50-conductor round cable. Two of these cables can be used to supply 100 conductors.

Figure 3-5
Typical round cable connection techniques

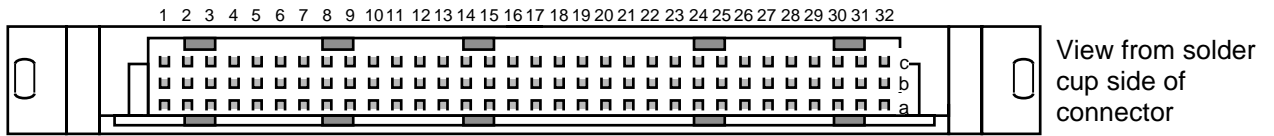

Note : See figure 3-4 for terminal identification

Figure 3-6
Model 7011-MTR connector pinout

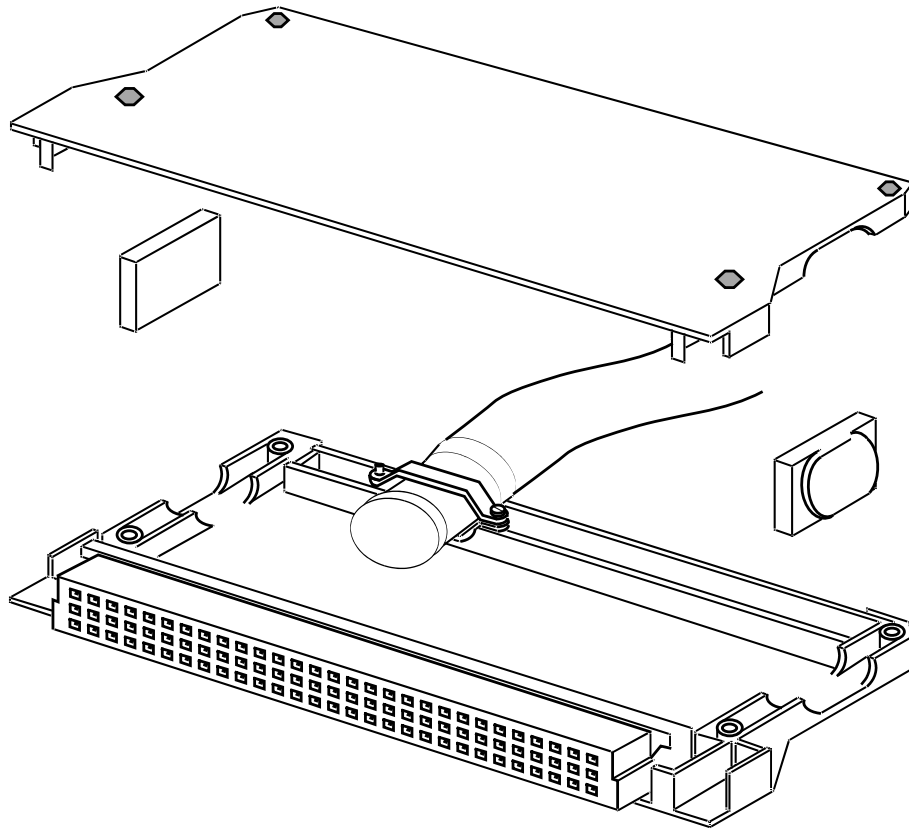

Figure 3-7
Model 7011-KIT-R (cable) assembly

3.4 Typical connection schemes

Paragraphs 3.4.1 and 3.4.2 show how the Model 7013 could be connected to a system that activates external devices and circuits. These are connection schemes for the relay switching example that is explained in paragraph 4.4.2 and illustrated in Figure 4-4.

Paragraph 3.4.1 describes a connection scheme using the multi-pin connector card of the Model 7013-C, while paragraph 3.4.2 describes a connection scheme using the screw terminal connector card of the Model 7013-S. Keep in mind that these are only examples to demonstrate a couple of ways to wire a system. Connection details for both connector cards are provided in paragraph 3.3.

If adding more Model 7013 cards to a system, simply wire them in the same manner as the first. Remember that two Model 7013 cards installed in the same mainframe are electrically isolated from each other. When two or more Model 7001 mainframes are used, they must be connected together (see Model 7001 Instruction Manual).

3.4.1 Connection scheme for Model 7013-C

Figure 3-8 shows how external connections can be made to the system using the multi-pin connector card. The Model 7011-MTC-2 cable assembly is cut in half to provide a cable that is unterminated at one end. The unterminated end of the cable can then be hard-wired directly to the external devices and power supplies. The other end will then mate to the Model 7013-C switch card assembly.

3.4.2 Connection scheme for Model 7013-S

Figure 3-9 shows how external connections can be made to the system using the screw terminal connector card. Single conductor (#16-22 AWG) connections are made directly from the screw terminals of the connector card to the external devices and power supplies.

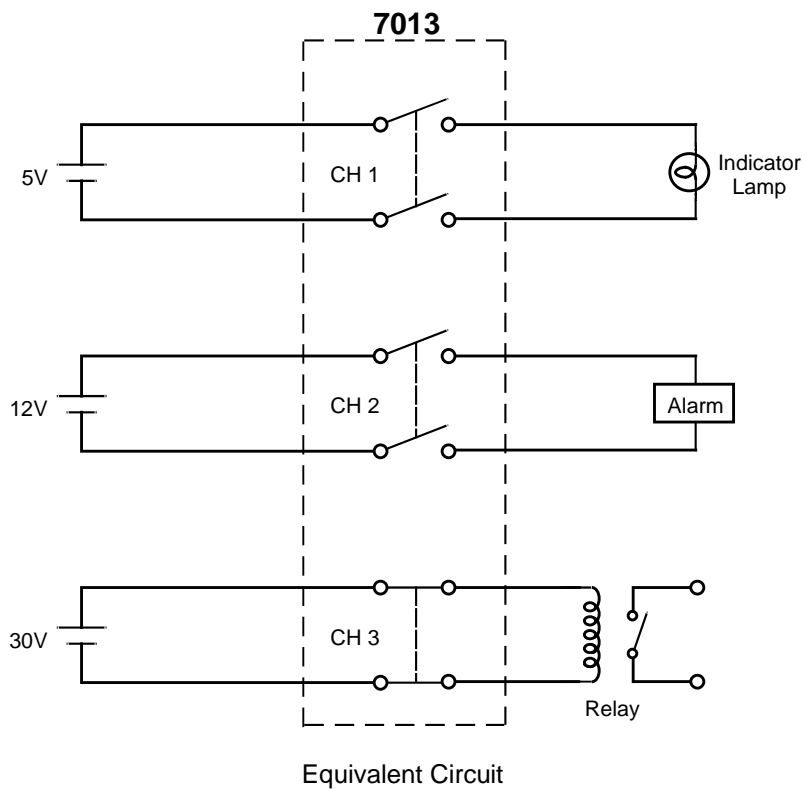
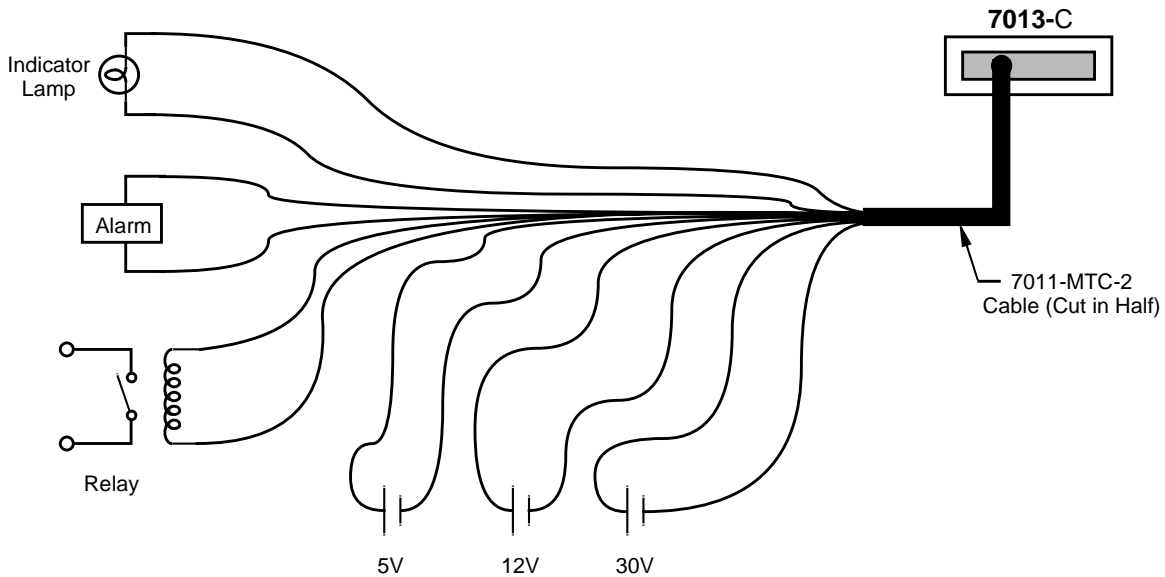

Figure 3-8
Typical connection scheme for Model 7013-C

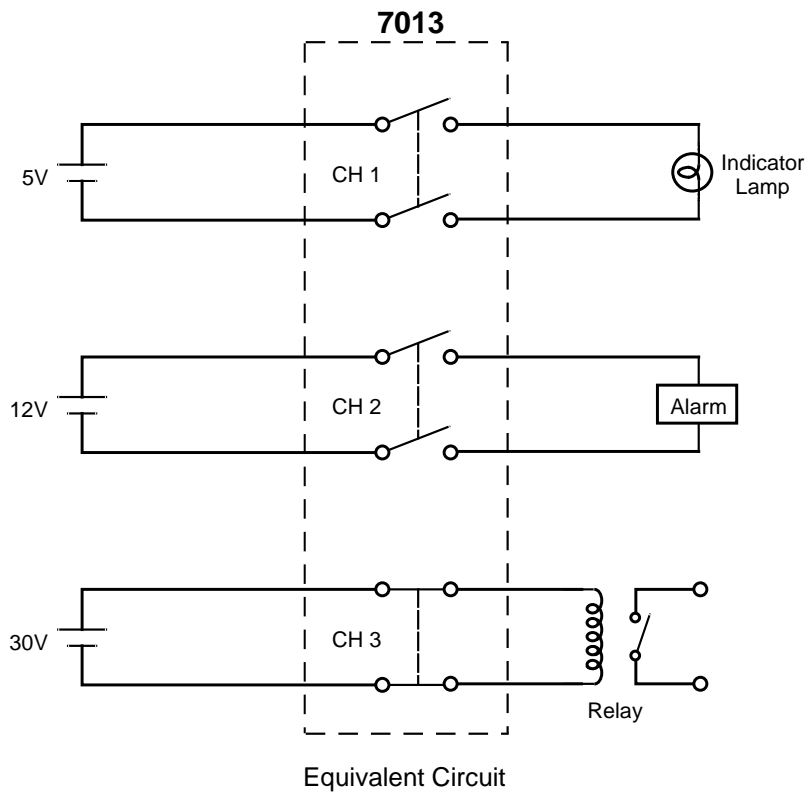
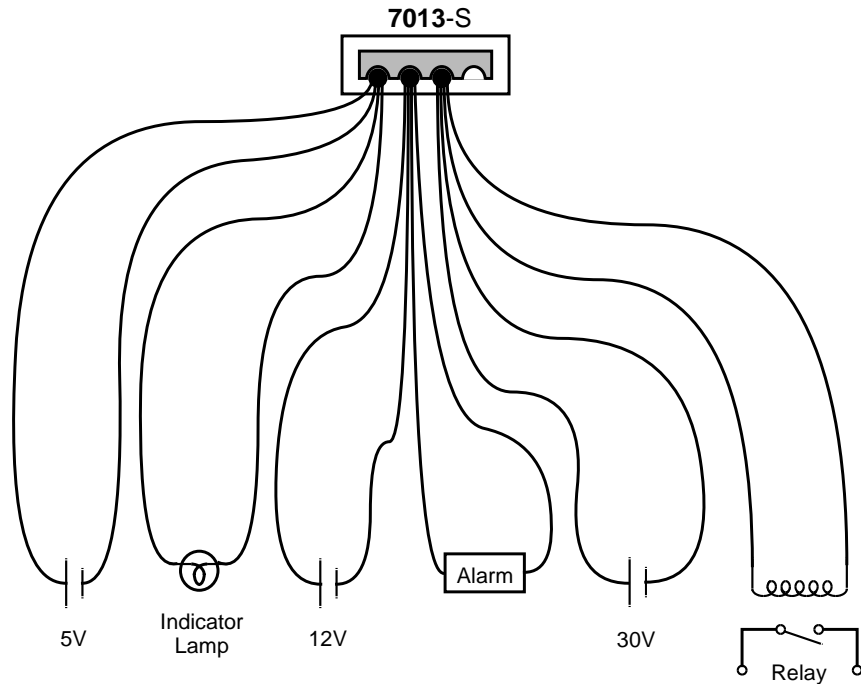

Figure 3-9
Typical connection scheme for Model 7013-S

3.5 Model 7013 installation and removal

This paragraph explains how to install and remove the Model 7013 switch card assembly from the Model 7001 mainframe.

WARNING

Installation or removal of the Model 7013 is to be performed by qualified service personnel. Failure to recognize and observe standard safety precautions could result in personal injury or death.

NOTE

If using the screw terminal connector card, make sure your external circuitry is wired to the card (as explained in paragraph 3.3.1) before installing the card assembly in the Model 7001 mainframe.

CAUTION

To prevent contamination to the switch card that could degrade performance, only handle the card assembly by the edges and shields.

Switch card installation

Perform the following steps to install the switch card assembly in the Model 7001 mainframe:

WARNING

Turn off power from all instrumentation (including the Model 7001 mainframe) and disconnect their line cords. Make sure all power is removed and any stored energy in external circuitry is discharged.

1. Mate the connector card to the relay card if they are separated. Install the supplied 4-40 screw to secure the assembly. Make sure to handle the cards by the edges and shields to prevent contamination.
2. Facing the rear panel of the Model 7001, select the slot (CARD 1 or CARD 2) that you wish to install the card in.
3. Referring to Figure 3-10 for Model 7013-S installation or Figure 3-11 for Model 7013-C installation, feed the switch card assembly into the desired slot such that the edges of the relay card ride in the rails.
4. With the ejector arms in the unlocked position, push the card assembly all the way into the mainframe until the arms engage into the ejector cups. Then push both arms inward to lock the card into the mainframe.
5. For the 7013-C, also install the screw shown in Figure 3-11.

Switch card removal

To remove the switch card assembly, first unlock it by pulling the latches outward, then pull the card assembly out of the mainframe. Remember to handle the card assembly by the edges and shields to avoid contamination that could degrade performance.

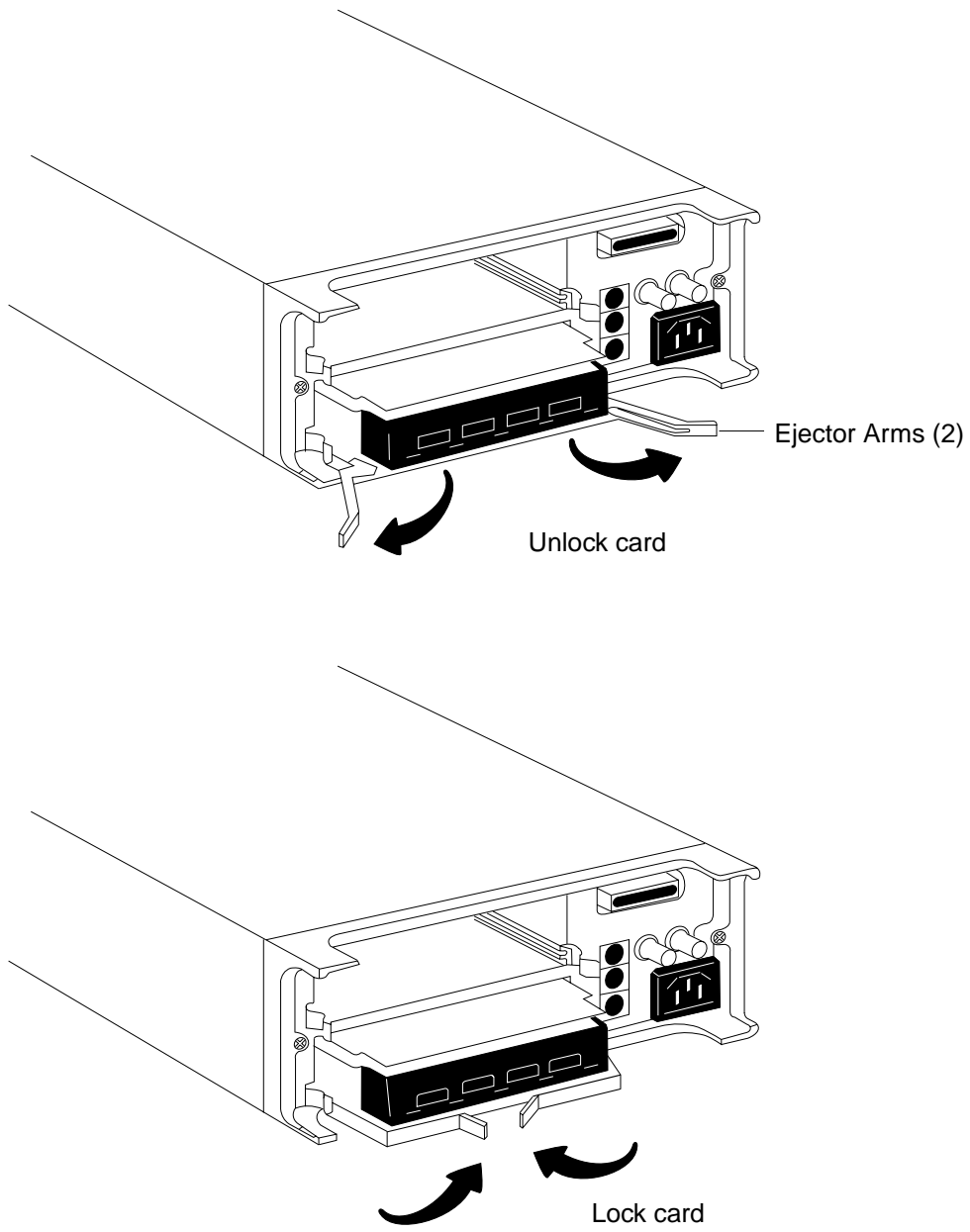

Figure 3-10
Model 7013-S card installation in Model 7001

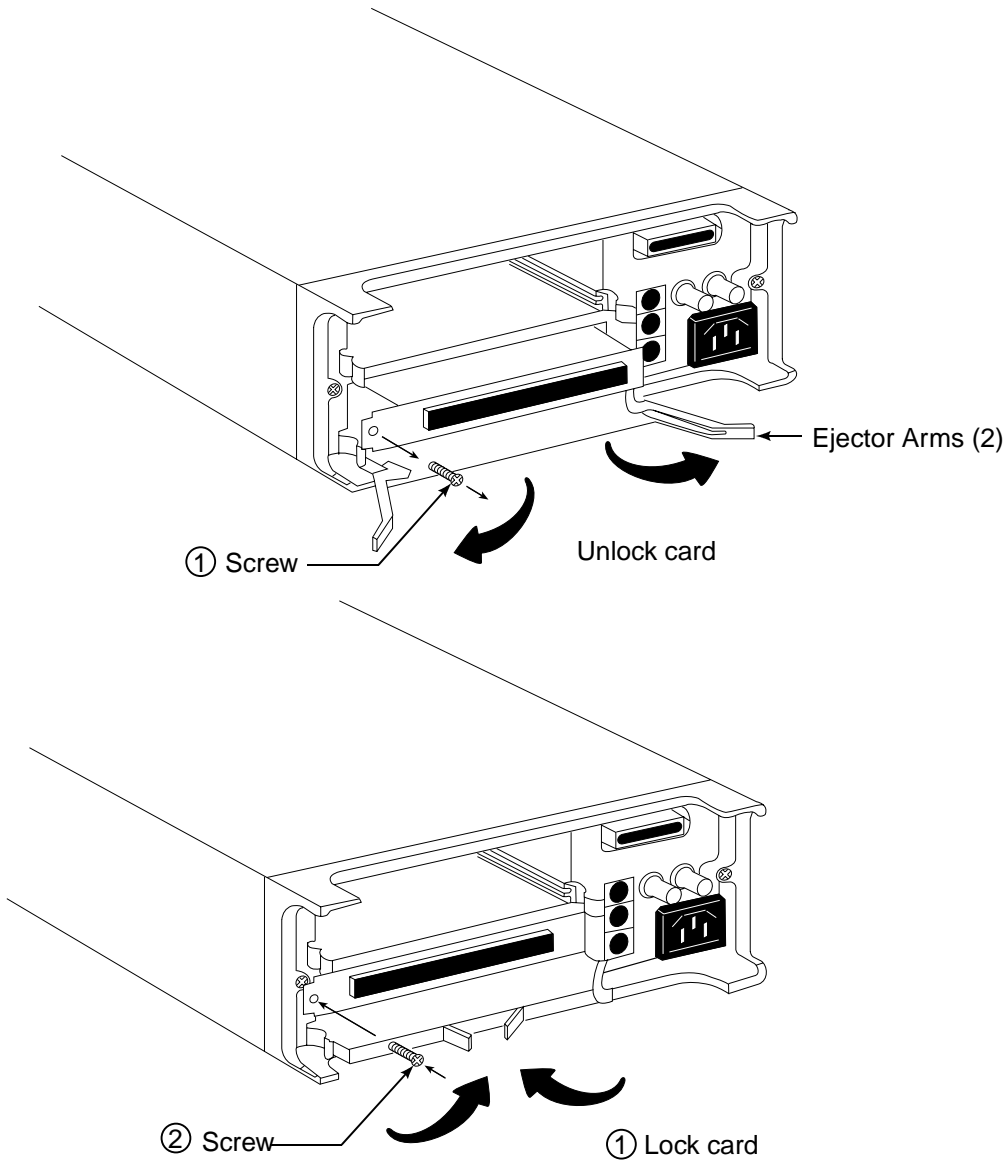

Figure 3-11
Model 7013-C card installation in Model 7001

4

Operation

4.1 Introduction

The information in this section is formatted as follows:

- 4.2 Power limits** : Summarizes the maximum power limits of the Model 7013 switch card assembly.
- 4.3 Mainframe control of switching card** : Summarizes programming steps to control the switch card from the Model 7001 Switch System mainframe.
- 4.4 Relay switching examples** : Provides some typical applications for using the Model 7013.
- 4.5 Measurement considerations** : Reviews a number of considerations when using the Model 7013 to make measurements.

4.2 Power limits

CAUTION

To prevent damage to the card, do not exceed the maximum signal level specifications of the card. For reactive loads, be sure to use voltage clamping and current limiting as explained in paragraph 4.2.2.

4.2.1 Maximum signal levels

To prevent overheating or damage to the relays, never exceed the following maximum signal levels:

DC signals: 110V between any two pins (terminals), 1A switched, 30VA (resistive load)

AC signals: 125V rms or 175V AC peak between any two pins (terminals), 1A switched, 60VA (resistive load)

4.2.2 Reactive loads

Operation is specified for resistive loads. Reactive loads require voltage clamping (for inductive loads) and current surge limiting (for capacitive loads) to prevent damage to the relays and to external circuitry.

Inductive loads — Inductive reaction voltage, must be limited to less than 110V in DC circuits or 175V peak in AC circuits. Also consider the load when determining the voltage limit. Clamping circuits that can be used are shown in Figure 4-1.

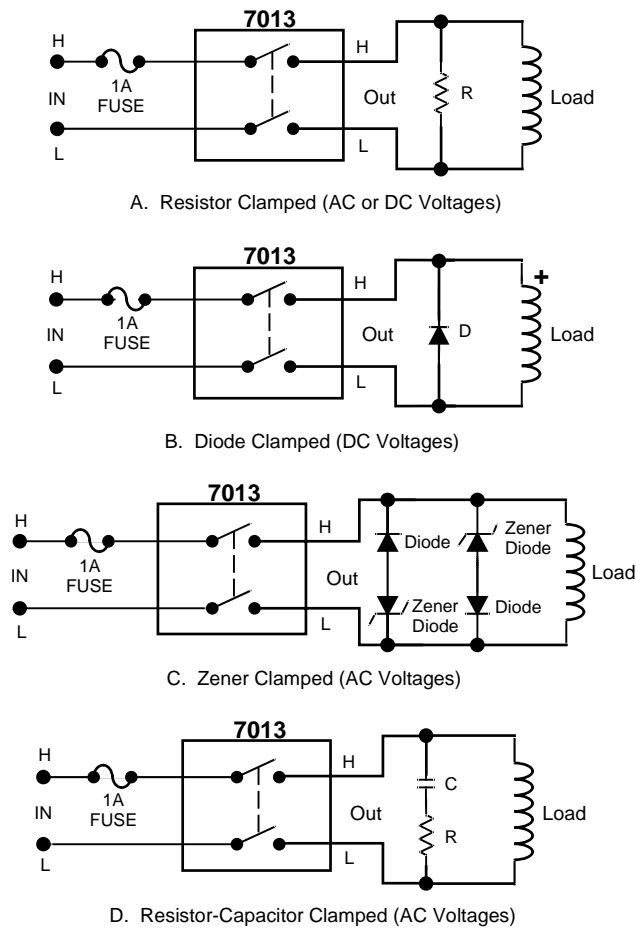

Figure 4-1
Limiting inductive reaction voltage

Capacitive loads — The initial surge current from a capacitive reactive load must be limited. Figure 4-2 shows circuits that can be used to limit current surges. To protect the relay, limit current to 1A. Also consider the load when determining the current surge limit.

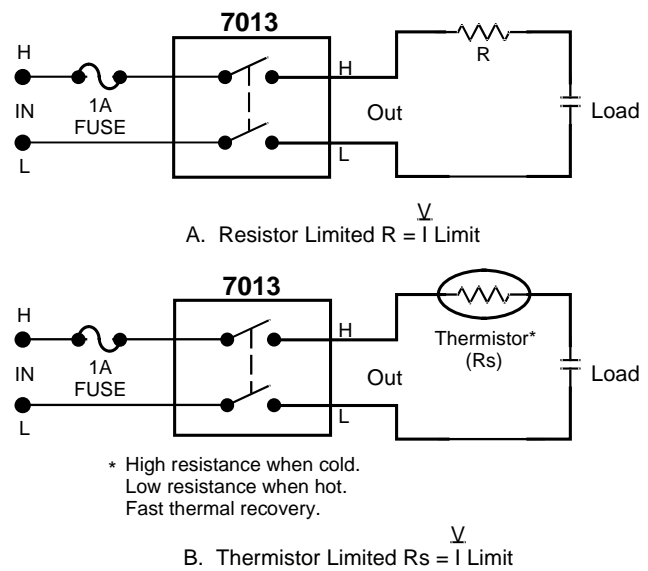

Figure 4-2
Limiting capacitive reaction current

4.3 Mainframe control of relay card

The following information pertains to the Model 7013 relay card. It assumes that you are familiar with the operation of the Model 7001 mainframe.

If you are not familiar with the operation of the mainframe, it is recommended that you proceed to Getting Started (Section 3) in the Model 7001 Instruction Manual after reading the following information.

4.3.1 Channel assignments

The Model 7001 has a channel status display (Figure 4-3) that provides the real-time state of each available channel. The left portion of the display is for slot 1 (Card 1), and the right portion is for slot 2 (Card 2). With two Model 7013 cards installed in the mainframe, only the 20 available channels of each card will be displayed as shown in Figure 4-3.

Relay organization of the channel status display for each slot is shown in Figure 4-4. The relay card contains 20 channels as shown in the illustration.

To control the relay card from the mainframe, each relay must have a unique CHANNEL assignment, which includes the slot number that the card is installed in. The CHANNEL assignments for the relay card are provided in Figure 4-5. Each CHANNEL assignment is made up of the slot designator (1 or 2) and the relay card channel. To be consistent with Model 7001 operation, the slot designator and relay card channel are separated by an exclamation point (!). Some examples of CHANNEL assignments are as follows:

- CHANNEL 1!1 = Slot 1, Channel 1
- CHANNEL 1!20 = Slot 1, Channel 20
- CHANNEL 2!2 = Slot 2, Channel 2
- CHANNEL 2!6 = Slot 2, Channel 6

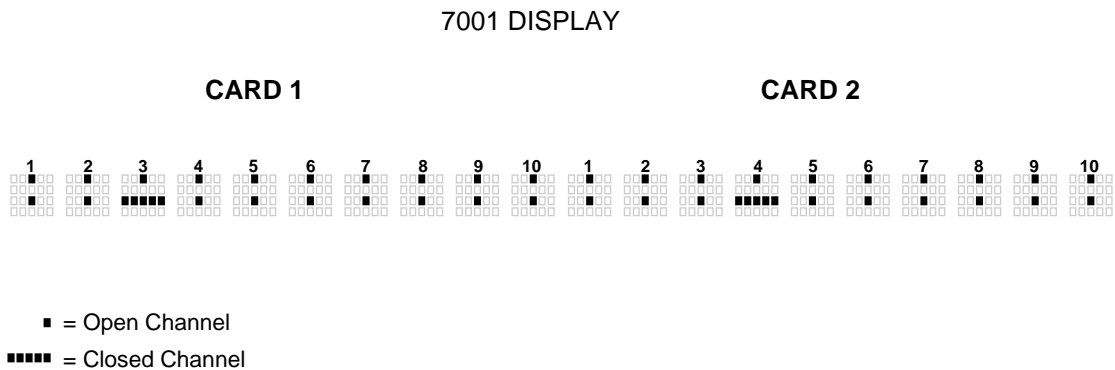

Figure 4-3
Channel status display (two Model 7013 cards installed)

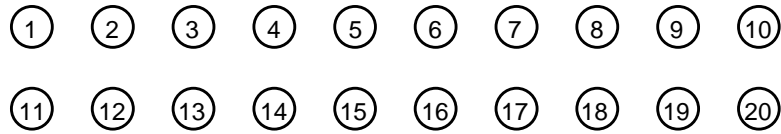
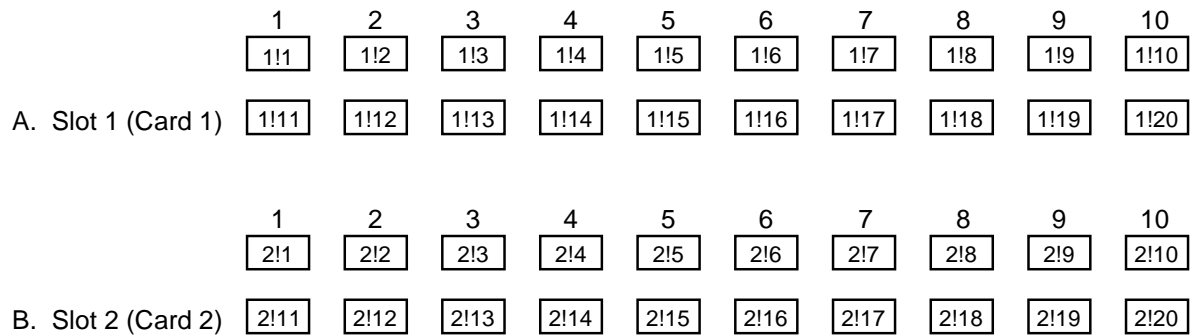

Figure 4-4
Display organization for relay card channels



Examples : 1!18 = Slot 1, Channel 18
2!3 = Slot 2, Channel 3

Figure 4-5
Channel assignments

4.3.2 Front panel control

Closing and opening channels

A channel is closed from the front panel by simply keying in the CHANNEL assignment and then pressing CLOSE. For example, to close channel 16 of a relay card installed in slot 2, key in the following channel list and press CLOSE:

```
SELECT CHANNELS 2!16
```

The above closed channel can be opened by pressing OPEN or OPEN ALL. The OPEN key opens only the channels specified in the channel list, and OPEN ALL opens all channels.

The following display is an example of a channel list that consists of several channels:

```
SELECT CHANNELS 2!1, 2!3, 2!12-2!15
```

Notice that channel entries are separated by commas (.). A comma is inserted by pressing ENTER or the right cursor key (▷). The channel range is specified by using the hyphen (-) key to separate the range limits. Pressing CLOSE will close all the channels specified in the channel list. Pressing OPEN (or OPEN ALL) will open the channels.

Scanning channels

Relay card channels are scanned by creating a scan list and configuring the Model 7001 to perform a scan. The scan list is created in the same manner as a channel list (see Closing and Opening Channels). However, the scan list is specified from the "SCAN CHANNEL" display mode. (The SCAN LIST key toggles between the channel list and the scan list.) The following shows an example of a scan list:

```
SCAN CHANNELS 2!1, 2!3, 2!11-2!15
```

When a scan is performed, the channels specified in the scan list will be scanned in the order that they are presented in the scan list.

A manual scan can be performed by using the RESET default conditions of the Model 7001. RESET is selected

from the SAVESETUP menu of the main MENU. When RESET is performed, the mainframe is configured for an infinite number of manual scans. The first press of STEP takes the mainframe out of the idle state. The next press of STEP will close the first channel specified in the scan list. Each subsequent press of STEP will select the next channel in the scan list.

4.3.3 IEEE-488 bus operation

Bus operation is demonstrated using HP BASIC 4.0. The programming statements assume that the primary address of the mainframe is 07.

Closing and opening channels

The following SCPI commands are used to close and open channels:

```
:CLOSe <list>
:OPEN <list> | ALL
```

The following statement closes channels 1!1, and 1!3 through 1!11:

```
OUTPUT 707; ":clos (@ 1!1, 1!3:1!11)"
```

Notice that the colon (:) is used to separate the range limits.

Either of the following statements will open channels 1!1, and 1!3 through 1!11:

```
OUTPUT 707; ":open (@ 1!1, 1!3:1!11)"
OUTPUT 707; ":open all"
```

Scanning channels

There are many commands associated with scanning. However, it is possible to configure a scan using as little as four commands. These commands are listed as follows:

```
*RST
:TRIGger:SEQUence:COUNt:AUTO ON"
:SCAN <list>
:INIT
```

The first command resets the mainframe to a default scan configuration. The second command automatically sets the channel count to the number of channels in the scan list, the third command defines the scan list, and the fourth command takes the Model 7001 out of the idle state.

The following program will perform a single scan through all 20 channels of a 7013 relay card installed in slot 1:

```
10 OUTPUT 707; "*RST"
20 OUTPUT 707; ":trig:seq:coun:auto on"
30 OUTPUT 707; ":scan (@ 1!1:1!20)"
40 OUTPUT 707; ":init"
50 END
```

- Line 10 Selects a default configuration for the scan.
- Line 20 Sets channel count to the scan-list-length.
- Line 30 Defines the scan list.
- Line 40 Take the Model 7001 out of the idle state. The scan is configured to start as soon as this command is executed.

When the above program is run, the scan will be completed in approximately 120msec (3msec delay for each relay closed and a 3msec delay for each open), which is too fast to view from the front panel. An additional relay delay can be added to the program to slow down the scan for viewing. The program is modified by adding line 25 to slow down the scan. Also, Line 5 is added to the beginning of the program to ensure that all channels are open before the scan is started.

```
5 OUTPUT 707; ":open all"
10 OUTPUT 707; "*RST"
20 OUTPUT 707; ":trig:seq:coun:auto on"
25 OUTPUT 707; ":trig:del 0.25"
30 OUTPUT 707; ":scan (@ 1!1:1!20)"
40 OUTPUT 707; ":INIT"
50 END
```

- Line 5 Opens all channels.
- Line 25 Sets a 1/4 second delay after each channel closes.

4.4 Relay switching examples

The independent IN/OUT circuits for each channel provide the means for some unique switching systems, some of which are described in the following paragraphs.

4.4.1 Controlling sources, supplies and loads

Figure 4-6 shows an example of a system that tests a DUT (device under test) by measuring its output. Of course the DUT can be tested by connecting the source, supply, and load directly to the DUT. However, switching these devices allows you to test the DUT under a variety of different conditions.

With the DUT properly biased (Channel 3 closed) you may want to test the output under three different input conditions; the normal source signal (Channel 1 open, Channel 2 closed), an open input (Channels 1 and 2 open), and a shorted input (Channel 1 closed, Channel 2 open).

CAUTION

To prevent possible damage to the source, do not allow Channels 1 and 2 to be closed at the same time. Doing so will short the output of the source.

Isolation between the input and output can be tested. By removing the power supply (Channel 3 open) the DUT can be tested to see if any part of the input signal appears at the output.

Output regulation of the DUT can be tested by comparing the output with load (Channel 4 closed) and without load (Channel 4 open).

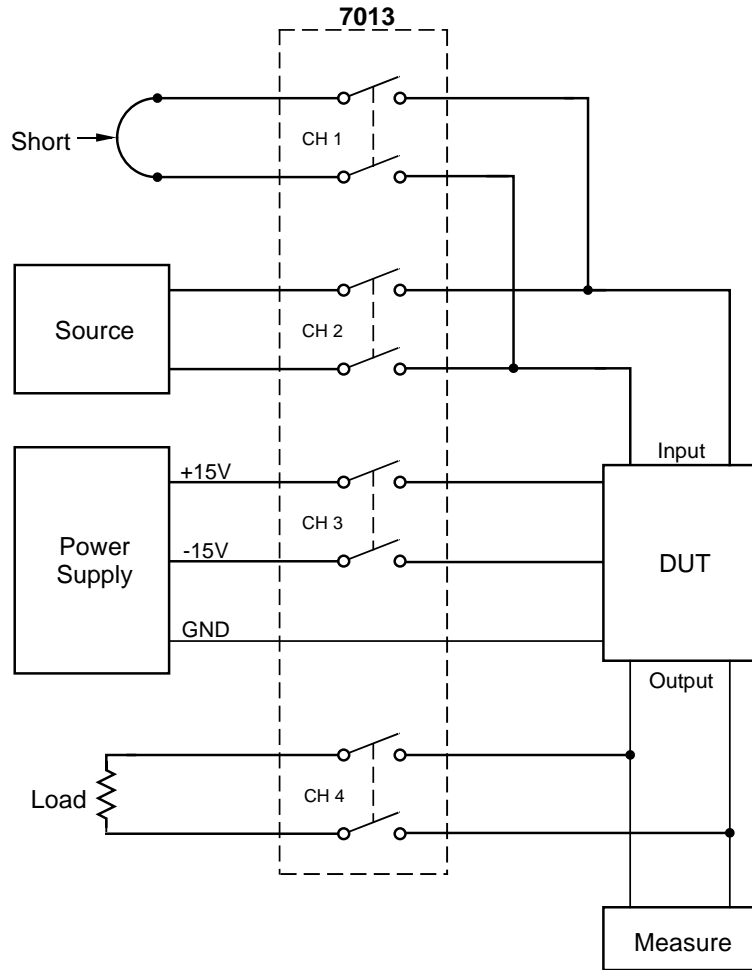

Figure 4-6
Controlling sources, supplies and loads

4.4.2 Activating external devices and circuits

The Model 7013 can be used to activate indicators, alarms, relays and other external control circuits.

As an example, assume that a simple computer based system is used to protect an expensive cutting tool on a lathe. The cutting tool must be constantly lubricated to keep it from burning up. The reservoir for the lubricant has a sensor circuit (such as a float switch) to detect when the lubricant level gets low. The sensor circuit is connected to the input port of the Model 7001.

As shown in Figure 4-7, the protection system includes a Model 7013 switch card which is used to control an indicator, an alarm, and an AC power control circuit. The illustration shows the state of the relays when the

lubricant level is normal. The indicator and alarm are disabled, and the AC power control circuit is enabled.

When the lubricant level gets low, the appropriate "low level" signal from the sensor circuit is detected causing the computer program to branch to a subroutine that will attend to the situation.

The program subroutine will close Channel 1 on the switch card which activates an indicator on a control panel alerting the operator that lubricant must be added to the reservoir. If after a particular time period the reservoir is not filled (level still low), Channel 2 will close to activate an audible alarm to alert the operator. If after another time period the lubricant level is still low, Channel 3 will open. This will deactivate (open) the relay which disables the AC power control circuit causing the lathe to shut down and thus, saves the cutting tool from being damaged.

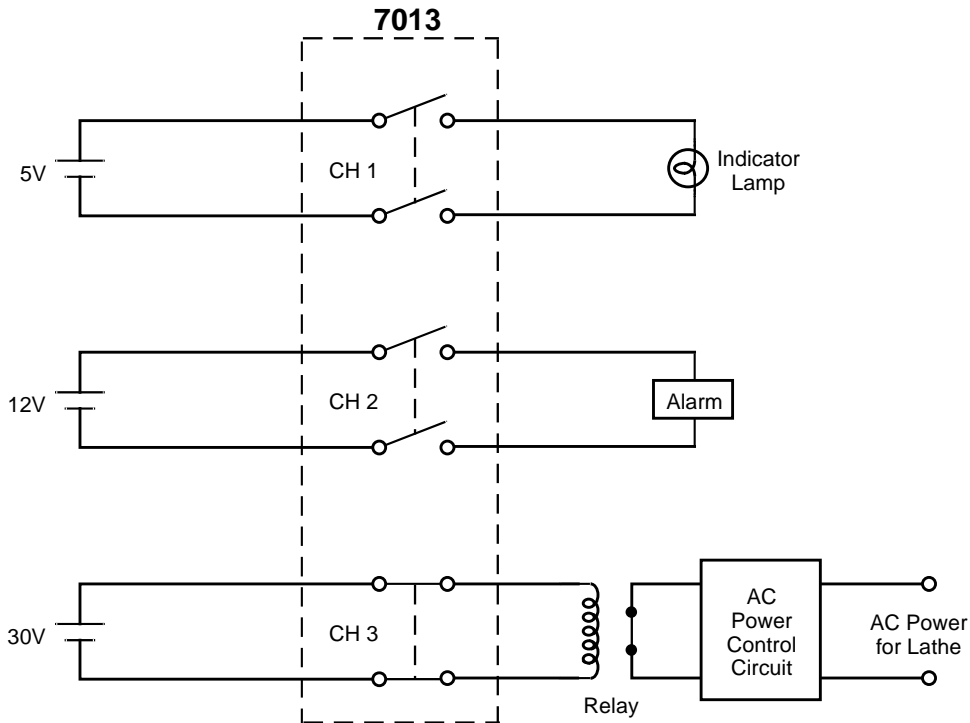

Figure 4-7
Controlling external devices and circuits

4.4.3 Switching loads

Figure 4-8 shows a test system that uses the Model 7013 to switch loads on the two outputs of the DUT. This system also demonstrates how to use a different type of card with the Model 7013. In this case, a Model 7011 multiplexer card is used to switch the DMM between Output #1 and Output #2.

With Channel 1 of the Model 7013 closed, Load 1 is placed on Output #1. With Channel 2 closed, Load 2

is placed on Output #1. Note that if both Channels 1 and 2 are closed at the same time, the parallel equivalent of Loads 1 and 2 is seen at the output. Channels 3 and 4 function in a similar manner for Loads 3 and 4 on Output #2.

Closing Channel 1 of the Model 7011 places the DMM on Output #1 to measure the voltage drop across the selected load. Conversely, closing Channel 2 places the DMM across the selected load for Output #2. To prevent invalid DMM readings, make sure both Channels 1 and 2 are not closed at the same time.

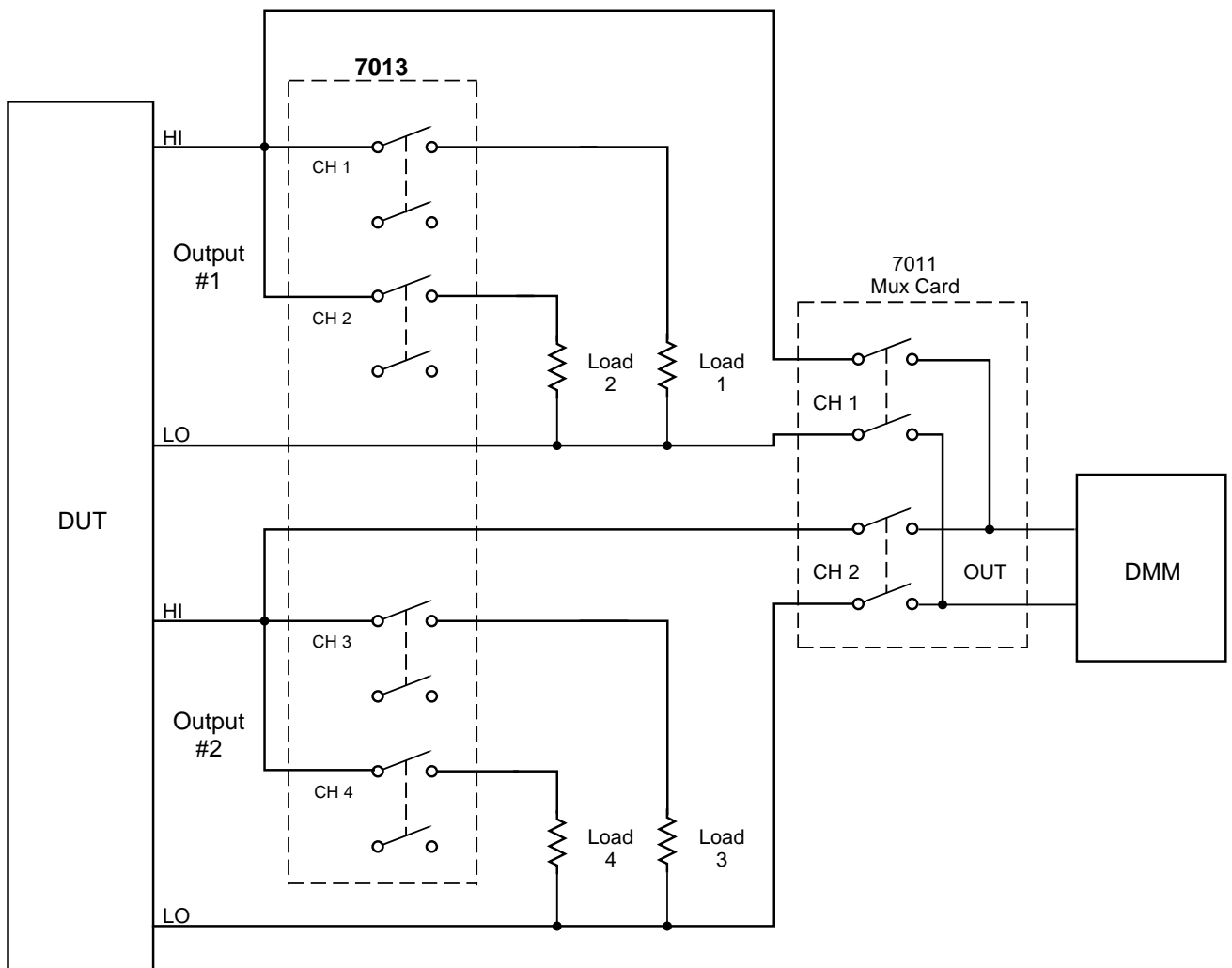

Figure 4-8
Switching loads

4.5 Measurement considerations

Many measurements made with the Model 7013 are subject to various effects that can seriously affect low-level measurement accuracy. The following paragraphs discuss these effects and ways to minimize them.

4.5.1 Path isolation

The path isolation is simply the equivalent impedance between any two test paths in a measurement system. Ideally, the path isolation should be infinite, but the actual resistance and distributed capacitance of cables and connectors results in less than infinite path isolation values for these devices.

Path isolation resistance forms a signal path that is in parallel with the equivalent resistance of the DUT, as shown in Figure 4-9. For low-to-medium device resistance values, path isolation resistance is seldom a consideration; however, it can seriously degrade measurement accuracy when testing high-impedance devices. The voltage measured across such a device, for example, can be substantially attenuated by the voltage divider action of the device source resistance and path isolation resistance, as shown in Figure 4-10. Also, leakage currents can be generated through these resistances by voltage sources in the system.

Any differential isolation capacitance affects DC measurement settling time as well as AC measurement accuracy. Thus, it is often important that such capacitance be kept as low as possible. Although the distributed capacitance of the switch card is generally fixed by design, there is one area where you do have control over the capacitance in your system; the connecting cables. To minimize capacitance, keep all cables as short as possible.

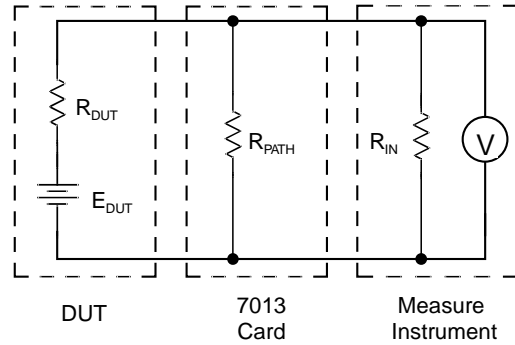

- R_{DUT} = Source Resistance of DUT
- E_{DUT} = Source EMF of DUT
- R_{PATH} = Path Isolation Resistance
- R_{IN} = Input Resistance of Measuring Instrument

Figure 4-9
Path isolation resistance

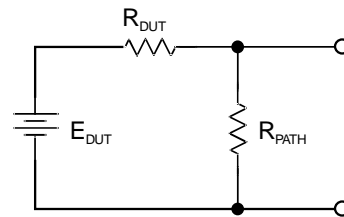

$$E_{OUT} = \frac{E_{DUT} R_{PATH}}{R_{DUT} + R_{PATH}}$$

Figure 4-10
Voltage attenuation by path isolation resistance

4.5.2 Magnetic fields

When a conductor cuts through magnetic lines of force, a very small current is generated. This phenomenon will frequently cause unwanted signals to occur in the test leads of a switching matrix system. If the conductor has sufficient length, even weak magnetic fields like those of the earth can create sufficient signals to affect low-level measurements.

Two ways to reduce these effects are: (1) reduce the lengths of the test leads, and (2) minimize the exposed circuit area. In extreme cases, magnetic shielding may be required. Special metal with high permeability at low flux densities (such as mu metal) is effective at reducing these effects.

Even when the conductor is stationary, magnetically-induced signals may still be a problem. Fields can be produced by various signals such as the AC power line voltage. Large inductors such as power transformers can generate substantial magnetic fields, so care must be taken to keep the switching and measuring circuits a good distance away from these potential noise sources.

At high current levels, even a single conductor can generate significant fields. These effects can be minimized by using twisted pairs, which will cancel out most of the resulting fields.

4.5.3 Radio frequency interference

RFI (Radio Frequency Interference) is a general term used to describe electromagnetic interference over a wide range of frequencies across the spectrum. Such RFI can be particularly troublesome at low signal levels, but is can also affect measurements at high levels if the problem is of sufficient severity.

RFI can be caused by steady-state sources such as radio or TV signals, or some types of electronic equipment (microprocessors, high speed digital circuits, etc.), or it can result from impulse sources, as in the case of arcing in high-voltage environments. In either case, the effect

on the measurement can be considerable if enough of the unwanted signal is present.

RFI can be minimized in several ways. The most obvious method is to keep the equipment and signal leads as far away from the RFI source as possible. Shielding the 7013 switching card, signal leads, sources, and measuring instruments will often reduce RFI to an acceptable level. In extreme cases, a specially-constructed screen room may be required to sufficiently attenuate the troublesome signal.

Many instruments incorporate internal filtering that may help to reduce RFI effects in some situations. In some cases, additional external filtering may also be required. Keep in mind, however, that filtering may have detrimental effects on the desired signal.

4.5.4 Ground loops

When two or more instruments are connected together, care must be taken to avoid unwanted signals caused by ground loops. Ground loops usually occur when sensitive instrumentation is connected to other instrumentation with more than one signal return path such as power line ground. As shown in Figure 4-11, the resulting ground loop causes current to flow through the instrument LO signal leads and then back through power line ground. This circulating current develops a small but undesirable voltage between the LO terminals of the two instruments. This voltage will be added to the source voltage, affecting the accuracy of the measurement.

Figure 4-12 shows how to connect several instruments together to eliminate this type of ground loop problem. Here, only one instrument is connected to power line ground.

Ground loops are not normally a problem with instruments having isolated LO terminals. However, all instruments in the test setup may not be designed in this manner. When in doubt, consult the manual for all instrumentation in the test setup.

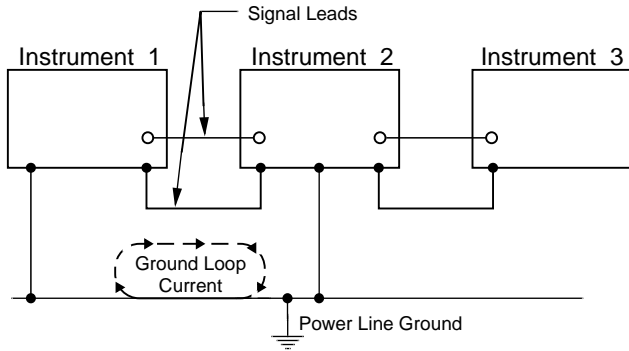

Figure 4-11
Power line ground loops

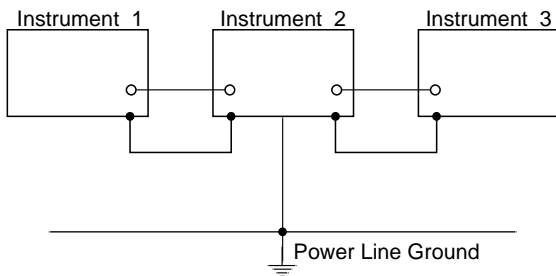

Figure 4-12
Eliminating ground loops

4.5.5 Keeping connectors clean

As is the case with any high-resistance device, the integrity of connectors can be damaged if they are not handled properly. If connector insulation becomes contaminated, the insulation resistance will be substantially reduced, affecting high-impedance measurement paths.

Oils and salts from the skin can contaminate connector insulators, reducing their resistance. Also, contaminants present in the air can be deposited on the insulator surface. To avoid these problems, never touch the connector insulating material. In addition, the 7013 card should be used only in clean, dry environments to avoid contamination.

If the connector insulators should become contaminated, either by inadvertent touching, or from air-borne deposits, they can be cleaned with a cotton swab dipped in clean methanol. After thorough cleaning, they should be allowed to dry for several hours in a low-humidity environment before use, or they can be dried more quickly using dry nitrogen.

4.5.6 AC frequency response

The AC frequency response of the Model 7013 is important in test systems that switch AC signals. Refer to the specifications at the front of this manual.

5

Service Information

WARNING

The information in this section is intended only for qualified service personnel. Some of the procedures may expose you to hazardous voltages that could result in personal injury or death. Do not attempt to perform these procedures unless you are qualified to do so.

5.1 Introduction

This section contains information necessary to service the Model 7013 relay card and is arranged as follows:

- 5.2 **Handling and cleaning precautions** — Discusses handling procedures and cleaning methods for the switch card.
- 5.3 **Performance verification** — Covers the procedures necessary to determine if the card is operating properly.
- 5.4 **Special handling of static-sensitive devices** — Reviews precautions necessary when handling static-sensitive devices.
- 5.5 **Principles of operation** — Briefly discusses circuit operation.
- 5.6 **Troubleshooting** — Presents some troubleshooting tips for the switch card.

5.2 Handling and cleaning precautions

Because of the high impedance circuits on the Model 7013, care should be taken when handling or servicing the card to prevent possible contamination, which could degrade performance. The following precautions should be taken when handling the switch card.

Do not store or operate the card in an environment where dust could settle on the circuit board. Use dry nitrogen gas to clean dust off the card if necessary.

Handle the card only by the side edges and shields. Do not touch any board surfaces, components, or connectors. Do not touch areas adjacent to electrical contacts. When servicing the card, wear clean, cotton gloves.

If making solder repairs on the circuit board, use an OA-based (organic activated) flux. Remove the flux from these areas when the repair is complete. Use pure water along with plenty of clean cotton swabs to remove the flux. Take care not to spread the flux to other areas of the circuit board. Once the flux has been removed, swab only the repaired area with methanol, then blow dry the board with dry nitrogen gas.

After cleaning, the card should be placed in a 50°C low humidity environment for several hours.

5.3 Performance verification

The following paragraphs discuss performance verification procedures for the Model 7013, including channel resistance, offset current, contact potential, and isolation.

CAUTION

Contamination will degrade the performance of the switch card. To avoid contamination, always grasp the card by the side edges and shields. Do not touch the connectors, and do not touch the board surfaces or components. On plugs and receptacles, do not touch areas adjacent to the electrical contacts.

NOTE

Failure of any performance verification test may indicate that the switch card is contaminated. See paragraph 5.2 to clean the card.

5.3.1 Environmental conditions

All verification measurements should be made at an ambient temperature between 18° and 28°C, and at a relative humidity of less than 70%.

5.3.2 Recommended equipment

Table 5-1 summarizes the equipment necessary for performance verification, along with an application for each unit.

*Table 5-1
Verification equipment*

| Description | Model or part | Specifications | Applications |
|----------------------------------|---------------------|--|--------------------------------|
| DMM | Keithley Model 196 | 300Ω; 0.01% | Path resistance |
| Electrometer w/voltage source | Keithley Model 617 | 10pA, 100pA; 1.6% 100V source; 0.2% | Offset current, path isolation |
| Sensitive Digital Voltmeter | Keithley Model 182 | 3mV; 60ppm | Contact potential |
| Triax cable (unterminated) | Keithley Model 7025 | — | Offset current |
| Low thermal cable (unterminated) | Keithley Model 1484 | — | Contact potential |

5.3.3 Switch card connections

The following information summarizes methods that can be used to connect test instrumentation to the two connector cards. Detailed connection information is provided in Section 3.

Model 7013-S — Instrumentation can be hard-wired directly to the screw terminals of the connector card. Jumper wires should be kept as short as possible.

Model 7013-C — One method to make instrument connections to the switch card is to hard-wire a 96-pin female DIN connector and then mate it to the connector on the Model 7013-C. Shorting connections can also be done at the connector. The connector in the Model 7011-KIT-R connection kit (see Table 3-1) can be used for this purpose. Pin identification for the multi-pin connector for the relay card is provided by Figure 3-4.

CAUTION

After making solder connections to a connector, remove solder flux as explained in paragraph 5.2. Failure to clean the solder connections could result in degraded performance, preventing the card from passing verification tests.

Before pre-wiring any connectors plugs, study the following test procedures to fully understand the connection requirements.

5.3.4 Channel resistance tests

Referring to Figure 5-1, perform the following steps to verify that each contact of every relay is closing properly and that the resistance is within specification.

1. Turn the Model 7001 off if it is on.
2. Set the Model 196 to the 300 Ω range and connect four test leads to the OHMS and OHMS SENSE input.
3. Short the four test leads together and zero the Model 196. Leave zero enabled for the entire test.
4. Connect OHMS HI and OHMS SENSE HI of the Model 196 to the input (IN) high (H) terminal of Channel 1 as shown in Figure 5-1A.
5. Connect OHMS LO and OHMS SENSE LO to the output (OUT) high (H) terminal of Channel 1.
6. With the card installed in slot 1 (CARD 1) of the mainframe, turn on the Model 7001 and program it to close channel 1!1 (Slot 1, Channel 1), and verify that the resistance of this channel is <1 Ω .
7. Turn off the Model 7001 and connect OHMS HI and OHMS SENSE HI of the Model 196 to the input (IN) low (L) terminal of Channel 1 as shown in Figure 5-1B.
8. Connect OHMS LO and OHMS SENSE LO to the output (OUT) low (L) terminal of Channel 1.
9. With the card installed in slot 1 (CARD 1) of the mainframe, turn on the Model 7001 and program it to close channel 1!1 (Slot 1, Channel 1), and verify that the resistance of this channel is <1 Ω .
10. Repeat the basic procedure of steps 1 through 9 to test the rest of the channels of the Model 7013 relay switch card. Remember to close the channel that the Model 196 is connected to.

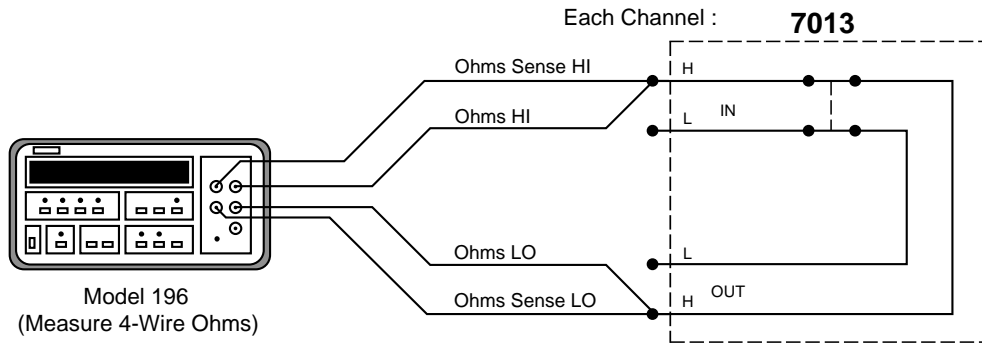

A) High Path Test

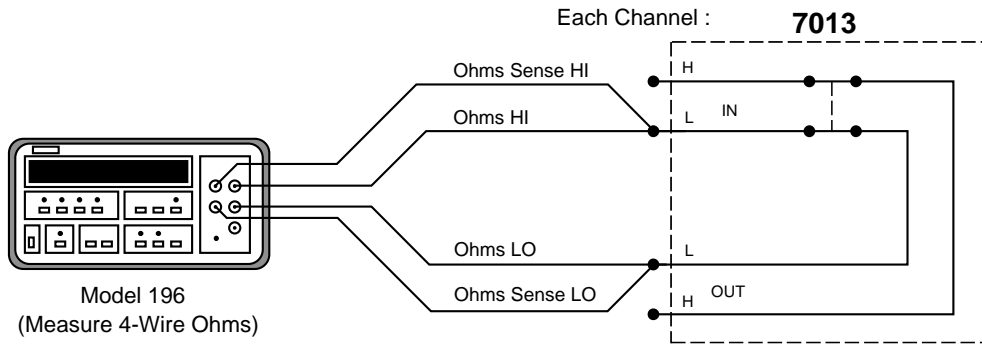

B) Low Path Test

Figure 5-1
Channel resistance testing

5.3.5 Offset current tests

These tests check leakage current from high (H) to low (L) (differential), and from high (H) and low (L) to chassis (common mode) for each channel. In general, these tests are performed by simply measuring the leakage current with an electrometer. In the following procedure, the Model 617 is used to measure leakage current.

Referring to Figure 5-2, perform the following procedure to check offset current:

1. Turn the Model 7001 off if it is on.
2. Connect the Model 617 electrometer to the input (IN) of Channel 1 as shown in Figure 5-2A.
3. Install the switch card in slot 1 (CARD 1) of the Model 7001 if it is not already installed.
4. On the Model 617, select the 200pA range, and enable zero check and zero correct in that order. Leave zero correct enabled for the entire procedure.
5. Turn on the Model 7001
6. Program the Model 7001 to close Channel 1!1.
7. On the Model 617, disable zero check and verify that it is <100pA. This measurement is the differential leakage current of the channel.
8. On the Model 617, enable zero check and turn the Model 7001 off.
9. Connect the Model 617 electrometer to Channel 1 as shown in Figure 5-2B. Note that electrometer HI is connected to both high (H) and low (L) of Channel 1 by using a jumper. Electrometer LO is connected to chassis ground, which is accessible at the rear panel of the mainframe.
10. Install the switch card in slot 1 (CARD 1) of the Model 7001 if it is not already installed.
11. On the Model 617, select the 200pA range, and enable zero check and zero correct in that order. Leave zero correct enabled for the entire procedure.

12. Turn on the Model 7001
13. Program the Model 7001 to close channel 1!1.
14. On the Model 617, disable zero check and verify that it is <100pA. This measurement is the common-mode leakage current of the channel.
15. On the Model 617, enable zero check.
16. Repeat the basic procedure in steps 1 through 15 to check the other channels. Remember to close the channel that the electrometer is connected to.

5.3.6 Contact potential tests

These tests check the EMF generated by each relay contact pair (H and L) for each channel. The tests simply consist of using a sensitive DVM (Model 182) to measure the contact potential.

Perform the following procedure to check contact potential of each path:

1. Turn the Model 7001 off if it is on.
2. As shown in Figure 5-3, short output (OUT) high (H) to low (L) of Channel 1. The low thermal short must be clean high purity copper.
3. Set the Model 182 to the 3mV range, short the input leads and press REL READING to null out internal offset. Leave REL enabled for the entire procedure.
4. Connect the Model 182 to a Channel 1 as shown in the illustration.
5. Install the switch card in slot 1 (CARD 1) of the Model 7001 if it is not already installed.
6. Turn on the Model 7001
7. Program the Model 7001 to close channel 1!1.
8. Verify that the reading on the Model 182 is <500nV. This measurement is the contact potential of the channel.
9. Repeat the basic procedure in steps 1 through 8 to test the rest of the channels of the Model 7013.

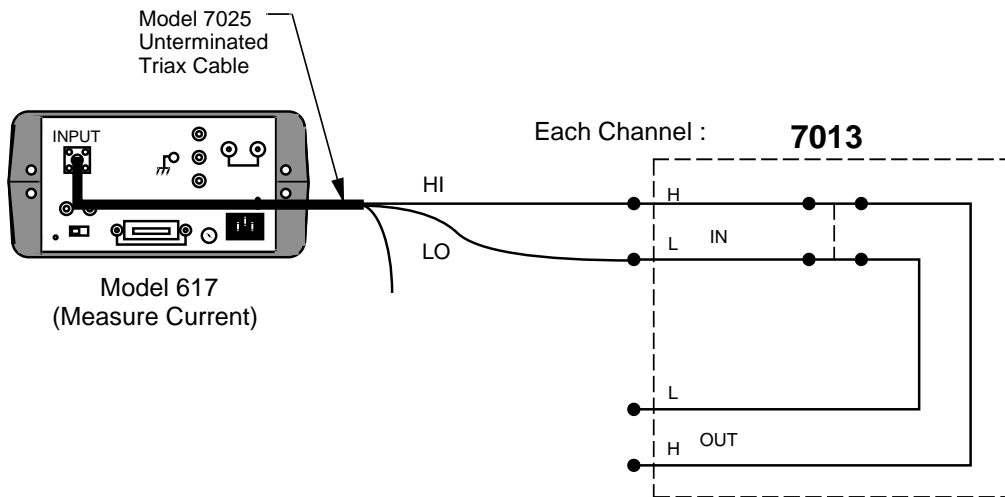

A) Differential Test

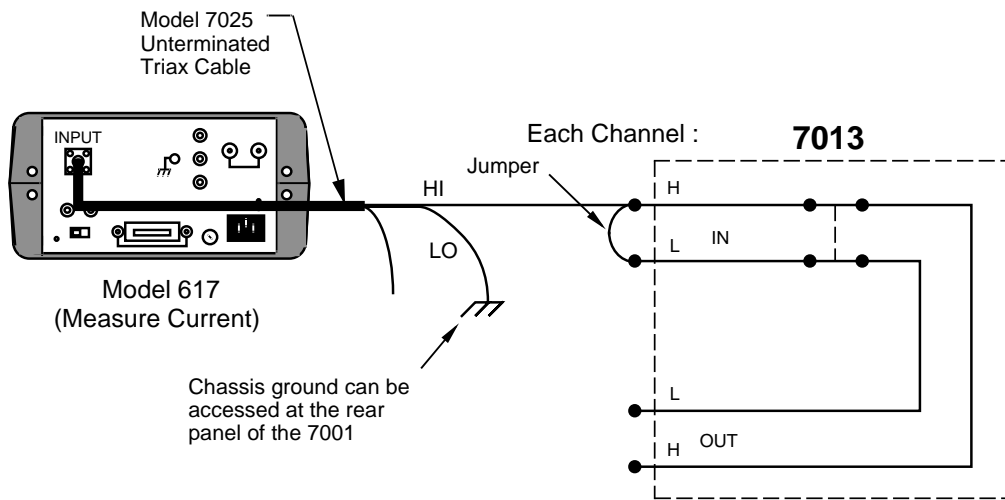

B) Common-Mode Test

Figure 5-2
Offset current testing

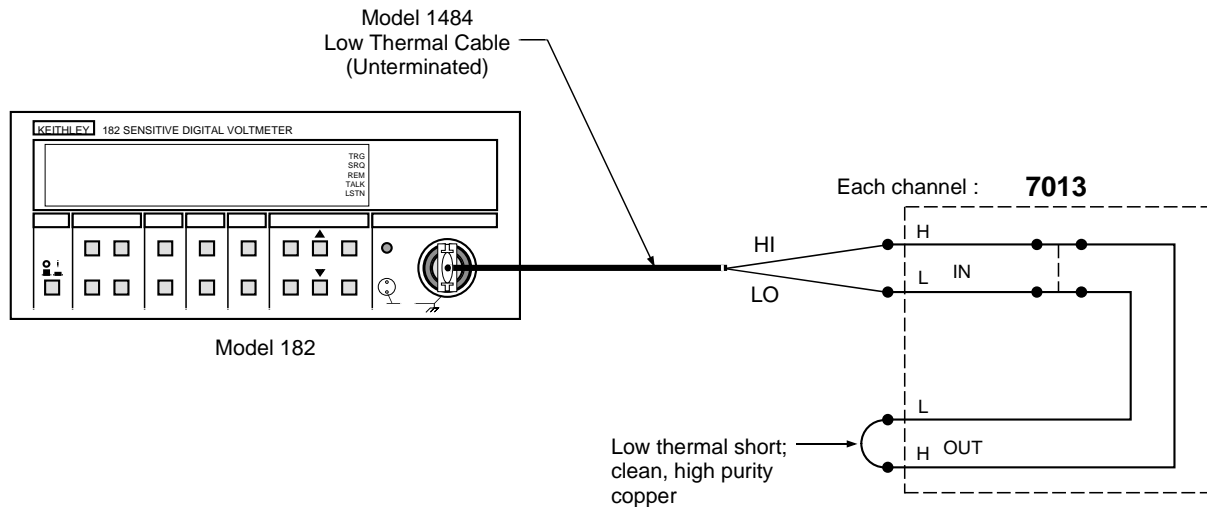

Figure 5-3
Contact potential testing

5.3.7 Channel to channel isolation tests

These tests check the leakage resistance (isolation) between adjacent channels. A channel is simply the high (H) and low (L) circuit from the input (IN) to the output (OUT) that results by closing the channel relay.

In general, the test is performed by applying a voltage (+100V) across two adjacent channels and then measuring the leakage current across the channels. The isolation resistance is then calculated as $R = V/I$. In the following procedure, the Model 617 functions as both a voltage source and an ammeter. In the V/I function, the Model 617 internally calculates the resistance from the known voltage and current levels and displays the resistance value.

Refer to Figure 5-4 and perform the following steps to test channel to channel isolation:

1. Turn the Model 7001 off if it is on.
2. Jumper input (IN) high (H) to input (IN) low (L) for Channels 1 and 2 as shown in Figure 5-4.
3. Connect the Model 617 to Channels 1 and 2 as shown in the illustration. Make sure the voltage source is in standby.
4. Install the Model 7013 in slot 1 (CARD 1) of the Model 7001 if it is not already installed.

WARNING

The following steps use high voltage (100V). Be sure to remove power from the circuit before making connection changes.

5. On the Model 617, select the 2pA range, and enable zero check and zero correct in that order. Leave zero correct enabled for the entire procedure.
6. On the Model 617, select the 20pA range and release zero check.
7. On the Model 617, press suppress to cancel offset current and then enable zero check.
8. On the Model 617, set the voltage source for +100V, and select the 20nA current range. Make sure the voltage source is in standby.
9. Place the Model 617 in the V/I measurement function by pressing SHIFT OHMS.
10. Turn on the Model 7001, and program it to close Channels 1!1 and 1!2 (Channels 1 and 2).
11. On the Model 617, disable zero check and press OPERATE to source +100V.
12. After allowing the reading on the Model 617 to settle, verify that it is $>10G\Omega$. This measurement is the channel to channel leakage resistance (isolation) between Channels 1 and 2.
13. Place the Model 617 in standby and enable zero check.
14. Turn off the Model 7001.

15. Disconnect the Model 617 from Channels 1 and 2, and, in a similar manner, reconnect it to Channels 2 and 3 (electrometer high to Channel 2, and voltage source high to Channel 3).
16. Install the card in slot 1 (CARD 1) of the Model 7001 if it is not already installed.
17. Turn on the Model 7001 and program it to close Channels 1!2 and 1!3.
18. On the Model 617, disable zero check and press OPERATE to source +100V.
19. After allowing the reading on the Model 617 to settle, verify that it is $>10G\Omega$. This is the isolation between Channels 2 and 3.
20. Using Table 5-2 as a guide, repeat the basic procedure of steps 13 through 19 for the rest of the path pairs (starting with test #3).

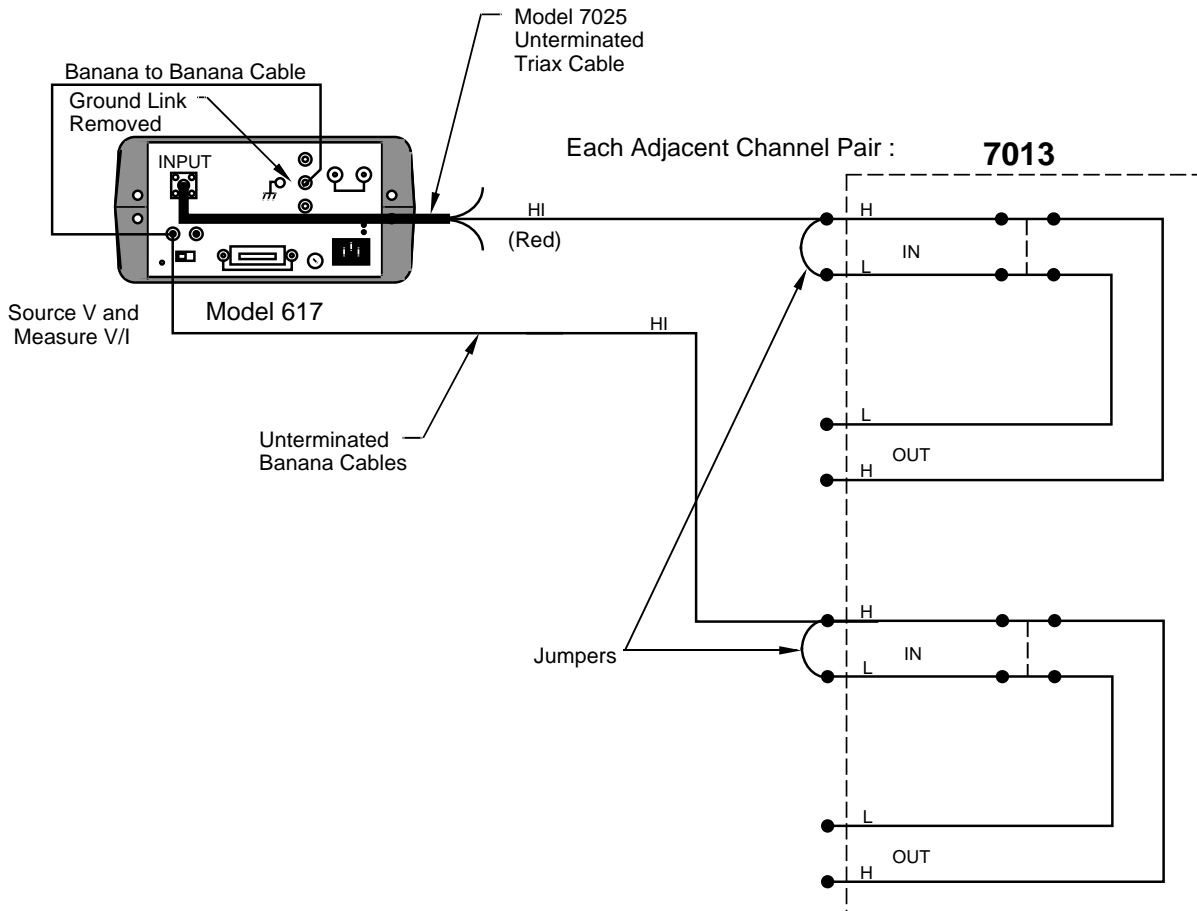

Figure 5-4
Channel to channel testing

Table 5-2
Channel to channel isolation tests

| Test no. | Isolation test | Test equipment location | Channels closed |
|-----------------|---------------------------|--------------------------------|------------------------|
| 1 | Channel 1 to Channel 2 | Channels 1 and 2 | 1!1 and 1!2 |
| 2 | Channel 2 to Channel 3 | Channels 2 and 3 | 1!2 and 1!3 |
| 3 | Channel 3 to Channel 4 | Channels 3 and 4 | 1!3 and 1!4 |
| 4 | Channel 4 to Channel 5 | Channels 4 and 5 | 1!4 and 1!5 |
| 5 | Channel 5 to Channel 6 | Channels 5 and 6 | 1!5 and 1!6 |
| 6 | Channel 6 to Channel 7 | Channels 6 and 7 | 1!6 and 1!7 |
| 7 | Channel 7 to Channel 8 | Channels 7 and 8 | 1!7 and 1!8 |
| 8 | Channel 8 to Channel 9 | Channels 8 and 9 | 1!8 and 1!9 |
| 9 | Channel 9 to Channel 10 | Channels 9 and 10 | 1!9 and 1!10 |
| 10 | Channel 10 to Channel 11 | Channels 10 and 11 | 1!10 and 1!11 |
| 11 | Channel 11 to Channel 12 | Channels 11 and 12 | 1!11 and 1!12 |
| 12 | Channel 12 to Channel 13 | Channels 12 and 13 | 1!12 and 1!13 |
| 13 | Channel 13 to Channel 14 | Channels 13 and 14 | 1!13 and 1!14 |
| 14 | Channels 14 to Channel 15 | Channels 14 and 15 | 1!14 and 1!15 |
| 15 | Channels 15 to Channel 16 | Channels 15 and 16 | 1!15 and 1!16 |
| 16 | Channels 16 to Channel 17 | Channels 16 and 17 | 1!16 and 1!17 |
| 17 | Channels 17 to Channel 18 | Channels 17 and 18 | 1!17 and 1!18 |
| 18 | Channel 18 to Channel 19 | Channels 18 and 19 | 1!18 and 1!19 |
| 19 | Channel 19 to Channel 20 | Channels 19 and 20 | 1!19 and 1!20 |

5.3.8 Differential isolation tests

These tests check the differential isolation (leakage resistance) between high (H) and low (L) of every channel.

In general, the test is performed by applying a voltage (100V) across the terminals and then measuring the leakage current. The isolation resistance is then calculated as $R = V/I$. In the following procedure, the Model 617 functions as a voltage source and an ammeter. In the V/I function, the Model 617 internally calculates the resistance from the known voltage and current levels and displays the resistance value.

Refer to Figure 5-5 and perform the following steps to test differential isolation.

1. Turn the Model 7001 off if it is on.
2. Connect the Model 617 to Channel 1 as shown in Figure 5-5. Make sure the voltage source is in standby.
3. Install the Model 7013 in slot 1 (CARD 1) of the Model 7001 if it is not already installed.

4. On the Model 617, select the 2pA range, and enable zero check and zero correct in that order. Leave zero correct enabled for the entire procedure.
5. On the Model 617, set the voltage source for +100V, and select the 20nA current range. Make sure the voltage source is still in standby.
6. Place the Model 617 in the V/I measurement function by pressing SHIFT OHMS.
7. Turn on the Model 7001 and program the Model 7001 to close Channel 1!1 (Slot 1, Channel 1).
8. On the Model 617, disable zero check and press OPERATE to source +100V.
9. After allowing the reading on the Model 617 to settle, verify that it is $>10G\Omega$. This measurement checks the differential isolation of Channel 1.
10. Enable zero check on the Model 617 and place its voltage source in standby.
11. Repeat the basic procedure in steps 1 through 10 to check differential isolation of the other channels of the Model 7013. Remember to close the relay of the channel being checked.
12. Place the Model 617 in standby and turn the Model 7001 off.

WARNING

The following steps use high voltage (100V). Be sure to remove power from the circuit before making connection changes.

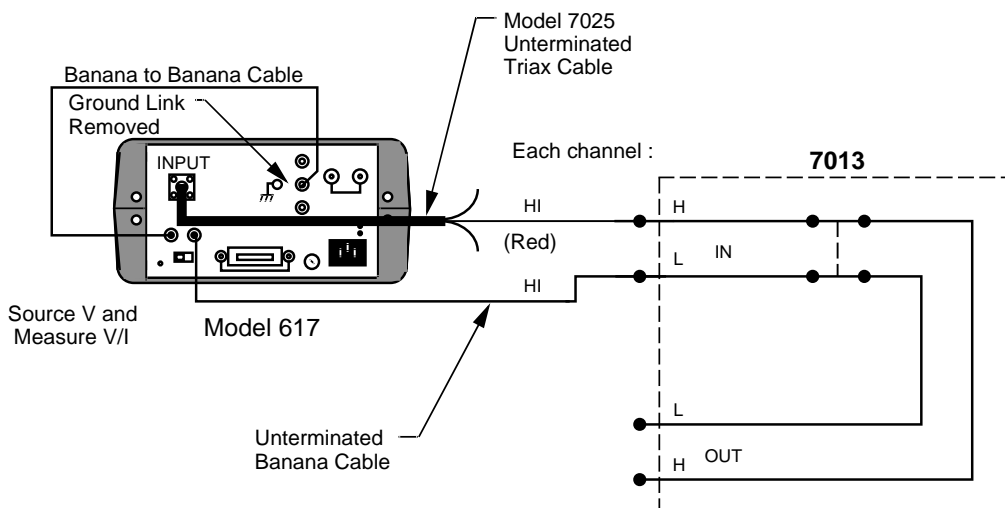

Figure 5-5
Differential isolation testing

5.3.9 Common-mode isolation tests

These tests check the common-mode isolation (leakage resistance) between high (H) and low (L) of every channel.

In general, the test is performed by applying a voltage (100V) and then measuring the leakage current. The isolation resistance is then calculated as $R = V/I$. In the following procedure, the Model 617 functions as a voltage source and an ammeter. In the V/I function, the Model 617 internally calculates the resistance from the known voltage and current levels and displays the resistance value.

Refer to Figure 5-6 and perform the following steps to test common-mode isolation.

1. Turn the Model 7001 off if it is on.
2. Connect the Model 617 to Channel 1 as shown in Figure 5-6. Make sure the voltage source is in standby. Note that the voltage source HI is connected to both input (IN) high (H) and low (L) by installing a jumper. Electrometer HI can be connected to chassis ground at the rear panel of the Model 7001.
3. Install the Model 7013 in slot 1 (CARD 1) of the Model 7001 if it is not already installed.

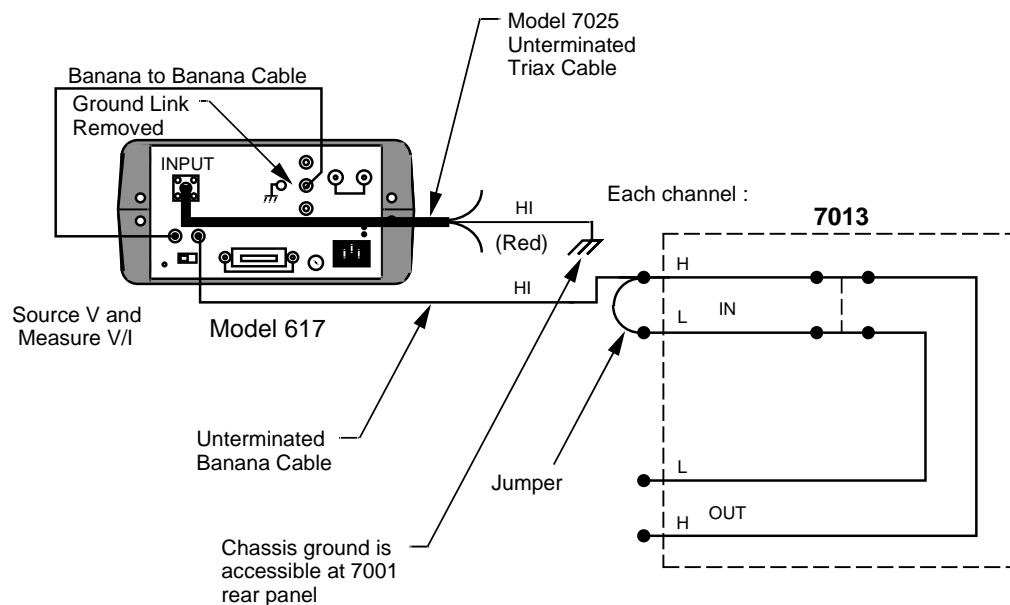

Figure 5-6
Common-mode isolation testing

WARNING

The following steps use high voltage (100V). Be sure to remove power from the circuit before making connection changes.

4. On the Model 617, select the 2pA range, and enable zero check and zero correct in that order. Leave zero correct enabled for the entire procedure.
5. On the Model 617, set the voltage source for +100V, and select the 20nA current range. Make sure the voltage source is still in standby.
6. Place the Model 617 in the V/I measurement function by pressing SHIFT OHMS.
7. Turn on the Model 7001 and program the Model 7001 to close Channel 1! (Slot 1, Channel 1).
8. On the Model 617, disable zero check and press OPERATE to source +100V.
9. After allowing the reading on the Model 617 to settle, verify that it is $>10G\Omega$. This measurement checks the common-mode isolation of Channel 1.
10. Enable zero check on the Model 617 and place its voltage source in standby.
11. Repeat the basic procedure in steps 1 through 10 to check differential isolation of the other channels of the Model 7013. Remember to close the relay of the channel being checked.
12. Place the Model 617 in standby and turn the Model 7001 off.

5.4 Special handling of static-sensitive devices

CMOS and other high-impedance devices are subject to possible static discharge damage because of the high-impedance levels involved. The following precautions pertain specifically to static-sensitive devices. However, since many devices in the Model 7013 are static-sensitive, it is recommended that they all be treated as static-sensitive.

1. Such devices should be transported and handled only in containers specially designed to prevent or dissipate static build-up. Typically, these devices will be received in anti-static containers made of plastic or foam. Keep these parts in their original containers until ready for installation.
2. Remove the devices from their protective containers only at a properly grounded work station. Also, ground yourself with a suitable wrist strap while working with these devices.
3. Handle the devices only by the body; do not touch the pins.
4. Any printed circuit board into which the device is to be inserted must first be grounded to the bench or table.
5. Use only anti-static type de-soldering tools and grounded-tip soldering irons.

5.5 Principles of operation

The paragraphs below discuss the basic operating principles for the Model 7013 and can be used as an aid in troubleshooting the switch card. The schematic drawing of the switch card is shown on drawing number 7013-106, located at the end of Section 6.

5.5.1 Block diagram

Figure 5-7 shows a simplified block diagram of the Model 7013. Key elements include the relay drivers and relays, as well as the ROM, which contains card ID and configuration information. These various elements are discussed in the following paragraphs.

5.5.2 ID data circuits

Upon power-up, card identification information from each card is read by the mainframe. This ID data includes such information as card ID, hardware settling time, and relay configuration information.

ID data is contained within an on-card EEPROM (U105). In order to read this information, the sequence described below is performed on power-up.

1. The IDDATA line (pin 6 of U105) is set from high to low while the IDCLK line (pin 5 of U105) is held high. This action initiates a start command to the ROM to transmit data serially to the mainframe (Figure 5-8).
2. The mainframe sends the ROM address location to be read over the IDDATA line. The ROM then transmits an acknowledge signal back to the mainframe, and it then transmits data at that location back to the mainframe (Figure 5-9).
3. The mainframe then transmits an acknowledge signal, indicating that it requires more data. The ROM will then sequentially transmit data after each acknowledge signal it receives.
4. Once all data is received, the mainframe sends a stop command, which is a low-to-high transition of the IDDATA line with the IDCLK line held high (see Figure 5-9).

5.5.3 Relay control

Card relays are controlled by serial data transmitted via the relay DATA line. A total of five bytes for each card are shifted in serial fashion into latches located in the card relay driver ICs. The serial data is clocked in by the CLK line. As data overflows one register, it is fed out the Q's line of the register down the chain.

Once all five bytes have shifted into the card, the STROBE line is set high to latch the relay information into the Q outputs of the relay drivers, and the appropriate relays are energized (assuming the driver outputs are enabled, as discussed below). Note that a relay driver output goes low to energize the corresponding relay.

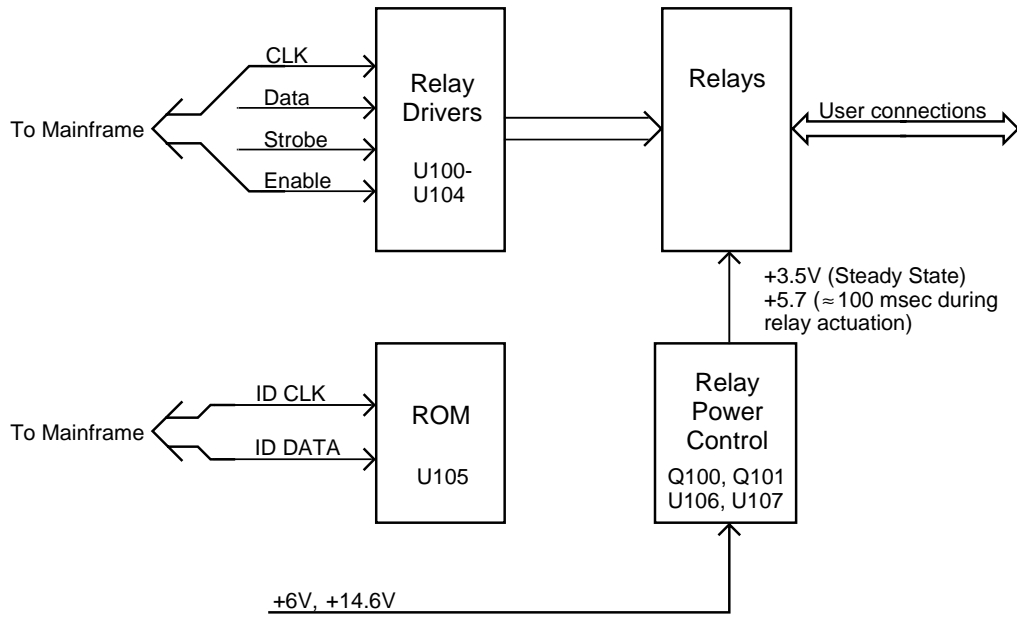

Figure 5-7
Model 7013 block diagram

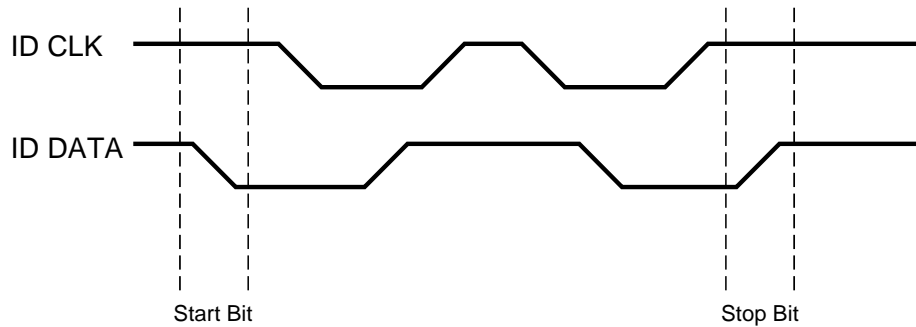

Figure 5-8
Start and stop sequences

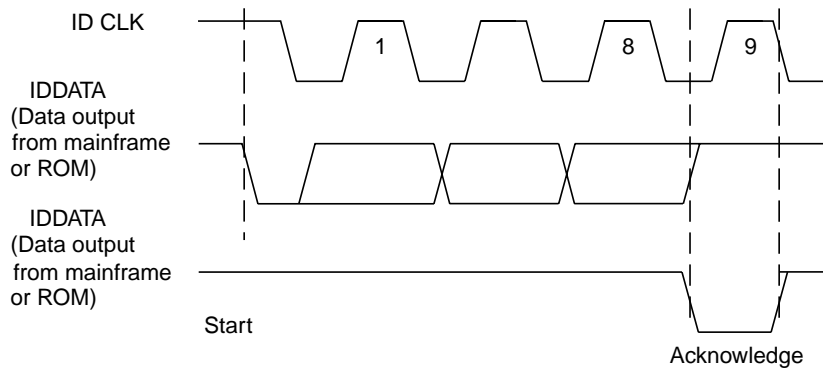

Figure 5-9
Transmit and acknowledge sequence

5.5.4 Relay power control

A relay power control circuit, made up of U106, U107, Q100, Q101, and associated components, keeps power dissipated in relay coils at a minimum, thus reducing possible problems caused by thermal EMFs.

During steady-state operation, the relay supply voltage, +V, is regulated to +3.5V to minimize coil power dissipation. When a relay is first closed, the STROBE pulse applied to U106 changes the parameters of the relay supply voltage regulator, Q100, allowing the relay supply voltage, +V, to rise to +5.7V for about 100ms. This brief voltage rise ensures that relays close as quickly as possible. After the 100ms period has elapsed, the relay supply voltage (+V) drops back down to its nominal steady-state value of +3.5V.

5.5.5 Power-on safeguard

NOTE

The power-on safeguard circuit discussed in the following paragraph is actually located on the digital board in the Model 7001 mainframe.

A power-on safeguard circuit, made up of U114 (a D-type flip-flop) and associated components ensures that relays do not randomly energize on power-up and power-down. This circuit disables all relays (all relays are open) during power-up and power-down periods.

The PRESET line on the D-type flip-flop is controlled by the 68302 microprocessor, while the CLK line of the D-type flip-flop is controlled by a port line on the 68302 processor. The Q output of the flip-flop drives each switch card relay driver IC enable pin (U100-U104, pin 8).

When the 68302 microprocessor is in the reset mode, the flip-flop PRESET line is held low, and Q out immediately goes high, disabling all relays (relay driver IC enable pins are high, disabling the relays.) After the reset condition elapses (≈ 200 msec), PRESET goes high while Q out stays high. When the first valid STROBE pulse occurs, a low logic level is clocked into the D-type flip-flop, setting Q out low and enabling all relay drivers simultaneously. Note that Q out stays low, (enabling relay drivers) until the 68302 processor goes into a reset condition.

5.6 Troubleshooting

5.6.1 Troubleshooting equipment

Table 5-3 summarizes recommended equipment for troubleshooting the Model 7013.

Table 5-3
Recommended troubleshooting equipment

| Description | Manufacturer and model | Application |
|--------------|------------------------|----------------------|
| Multimeter | Keithley 196 | Measure DC voltages |
| Oscilloscope | TEK 2243 | View logic waveforms |

5.6.2 Troubleshooting access

In order to gain access to the relay card top surface to measure voltages under actual operation conditions, perform the following steps:

1. Disconnect the connector card from the relay card.
2. Remove the Model 7001 cover.
3. Install the relay card in the CARD 1 slot location.
4. Turn on Model 7001 power to measure voltages (see following paragraph).

5.6.3 Troubleshooting procedure

Table 5-4 summarizes switch card troubleshooting.

CAUTION

Observe the following precautions when troubleshooting or repairing the switch card:

To avoid contamination, which could degrade card performance, always handle the card only by the handle and side edges. Do not touch edge connectors, board surfaces, or components on the card. Also, do not touch areas adjacent to electrical contacts on connectors.

Use care when removing relays from the PC board to avoid pulling traces away from the circuit board. Before attempting to remove a relay, use an appropriate de-soldering tool such as a solder sucker to clear each mounting hole completely free of solder. Each relay pin must be free to move in its mounting hole before removal. Also, make certain that no burrs are present on the ends of the relay pins.

Table 5-4
Troubleshooting procedure

| Step | Item/component | Required condition | Comments |
|-------------|-----------------------|--|--|
| 1 | GND pad | | All voltages referenced to digital ground (GND pad). |
| 2 | +6V pad | +6VDC | Relay voltage. |
| 3 | +5V pad | +5VDC | Logic voltage. |
| 4 | +14.6V pad | +14.6VDC | Relay bias voltage. |
| 5 | +V pad | +3.5VDC* | Regulated relay voltage. |
| 6 | U105, pin 5 | ID CLK pulses | During power-up only. |
| 7 | U105, pin 6 | ID DATA pulses | During power-up only. |
| 8 | U100, pin 7 | STROBE pulse | End of relay update sequence. |
| 9 | U100, pin 2 | CLK pulses | During relay update sequence only. |
| 10 | U100, pin 3 | DATA pulses | During relay update sequence only. |
| 11 | U100-U104, pins 10-18 | Low with relay energized; high with relay de-energized. | Relay driver outputs. |

*+3.5VDC present at +V pad under steady-state conditions. This voltage rises to +5.7VDC for about 100msec when relay configuration is changed.

6

Replaceable Parts

6.1 Introduction

This section contains replacement parts information, schematic diagrams, and component layout drawings for the Model 7013.

1. Card model number 7013
2. Card serial number
3. Part description
4. Circuit description, if applicable
5. Keithley part number

6.2 Parts lists

Parts lists for the various circuit boards are included in tables integrated with schematic diagrams and component layout drawings for the boards. Parts are listed alphabetically in order of circuit designation.

6.3 Ordering information

To place an order, or to obtain information concerning replacement parts, contact your Keithley representative or the factory (see inside front cover for addresses). When ordering parts, be sure to include the following information:

6.4 Factory service

If the card is to be returned to Keithley Instruments for repair, perform the following:

1. Complete the service form at the back of this manual and include it with the card.
2. Carefully pack the card in the original packing carton.
3. Write ATTENTION REPAIR DEPT on the shipping label.

Note: It is not necessary to return the matrix mainframe with the card.

6.5 Component layouts and schematic diagrams

Component layout drawings and schematic diagrams are included on the following pages with the parts lists:

Table 6-1 Parts List, Relay Card for 7013-S and 7013-C.

Table 6-2 Parts List, Screw Terminated Connector Card for 7013-S.

Table 6-3 Parts List, Mass Terminated Connector Card for 7013-C.

7013-100 Component Layout, Relay Card for 7013-S and 7013-C.

7013-106 Schematic, Relay Card for 7013-S and 7013-C.

7013-160 Component Layout, Screw Terminated Connector Card for 7013-S.

7013-166 Schematic, Screw Terminated Connector Card for 7013-S.

7013-170 Component Layout, Mass Terminated Connector Card for 7013-C

7013-176 Schematic, Mass Terminated Connector Card for 7013-C.

Table 6-1
Relay board for Model 7013-S and 7013-C, parts list

| Circuit designation | Description | Keithley part number |
|------------------------------|--|----------------------|
| | EJECTOR ARM | 7011-301 |
| | ROLL PIN (FOR EJECTOR ARMS) | DP-6-1 |
| | SHIELD | 7011-305 |
| | SOCKET (FOR U105) | SO-72 |
| | 2-56 × ¼ PHILLIPS PAN HD (FOR SCANNER SHIELD) | 2-56 × ¼ PPH |
| | 2-56 × PHILLIPS PAN HEAD (P2001 TO STANDOFF) | 2-56 × PPH |
| | 4-40 × ¼ PHILLIPS PAN HD SEMS SCREW (SCANNER BD TO TERMINAL BD) | 4-40 × ¼ PPHSEM |
| | 4-40 × ¾ PHIL. PAN HD SEMS (FOR Q100) | 4-40 × ¾ PPHSEM |
| C101-103,105-109,116,117,118 | CAP, .1µF, 20%, 50V, CERAMIC | C-365-.1 |
| C110,111 | CAP, 1µF, 20%, 50V, CERAMIC | C-237-1 |
| C112 | CAP, 0.001µF, 20%, 500V, CERAMIC | C-22-.001 |
| C113-115 | CAP, 10µF, -20+100%, 25V, ALUM ELEC | C-314-10 |
| C119,120,121 | CAP, 150pF, 10%, 1000V, CERAMIC | C-64-150P |
| CR100-119 | DIODE, SILICON, IN4148 (DO-35) | RF-28 |
| J1002,1003 | CONNECTOR, MALE | CS-736-2 |
| K100-119 | RELAY, ULTRA-SMALL POLARIZED TF2E-5V | RL-149 |
| P2001 | CONNECTOR, RIGHT ANGLE MALE | CS-775-1 |
| Q100 | TRANS, NPN PWR, TIP31 (TO-220AB) | TG-253 |
| Q101 | TRANS, N CHAN MOSPOW FET, V11713 (TO-92) | TG-195 |
| R100 | RES, 2.49K, 1%, W, METAL FILM | R-88-2.49K |
| R101 | RES, 1.15K, 1%, W, METAL FILM | R-88-1.15K |
| R102,103 | RES, 1K, 5%, ¼ W, COMPOSITION OR FILM | R-76-1K |
| R104 | RES, 1K, 1%, W, METAL FILM | R-88-1K |
| R105 | RES, 220K, 5%, ¼ W, COMPOSITION OR FILM | R-76-220K |
| R106 | RES, 10K, 5%, ¼ W, COMPOSITION OR FILM | R-76-10K |
| U101-103 | IC, 8-BIT SERIAL-IN LATCH DRIVER, 5841A | IC-536 |
| U105 | EPROM PROGRAM | 7013-800-*** |
| U106 | IC, RETRIG MONO MULTIVIB, 74HC123 | IC-492 |
| U107 | IC, AJD SHUNT REGULATOR, TL431CLP | IC-677 |

*** Order current firmware revision level.

001-2102.DN

| LTR. | ECD NO. | REVISION | ENG. | DATE |
|------|---------|--------------------------|------|----------|
| C | 910920 | RELEASED | MS | 9-20-91 |
| D | 15452 | REVISED | SZ | 12-17-93 |
| D2 | 25918 | CHANGED U105 TO TC17-100 | ELS | 6/20/01 |

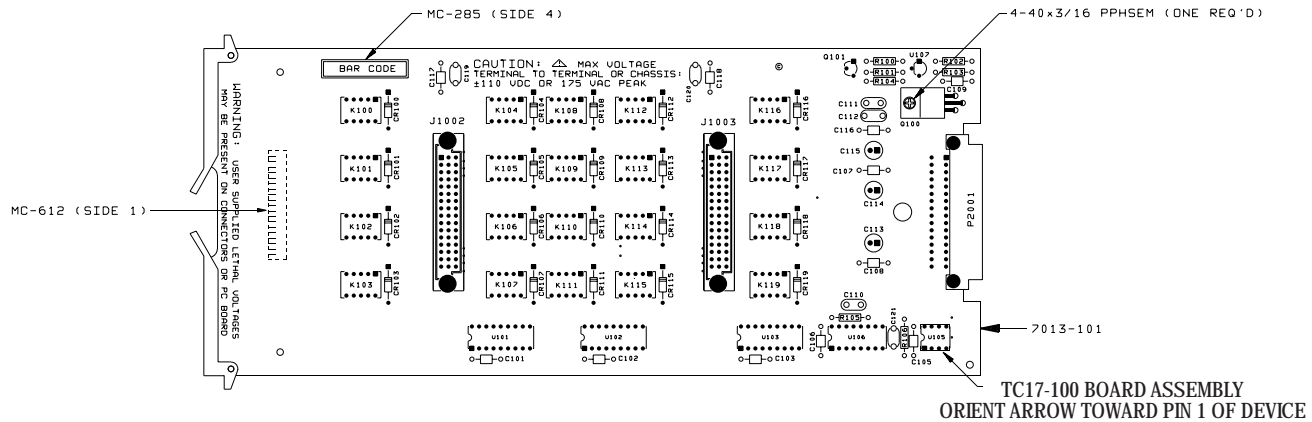

NOTE: FOR COMPONENT INFORMATION, REFER TO PRODUCT STRUCTURE

| MODEL | NEXT ASSEMBLY | QTY. |
|-------|---------------|------|
| | | |
| | | |
| | | |

| | | | | | | |
|---|--|---|--|--------------|------------------|-----------------------------------|
| DO NOT SCALE THIS DRAWING | | DIMENSIONAL TOLERANCES UNLESS OTHERWISE SPECIFIED | | DATE 9/16/91 | SCALE 1:1 | TITLE |
| XX±.015 | | ANG. ±.1° | | DRN. KEK | ENG. RPPS, MK/CM | COMPONENT LAYOUT SCANNER BOARD |
| KEITHLEY KEITHLEY INSTRUMENTS INC. CLEVELAND, OHIO 44139 | | FRAC. ±.1/64 | | MATERIAL | | NO. 7013-100 |
| SURFACE MAX. 63 | | FINISH | | | | |

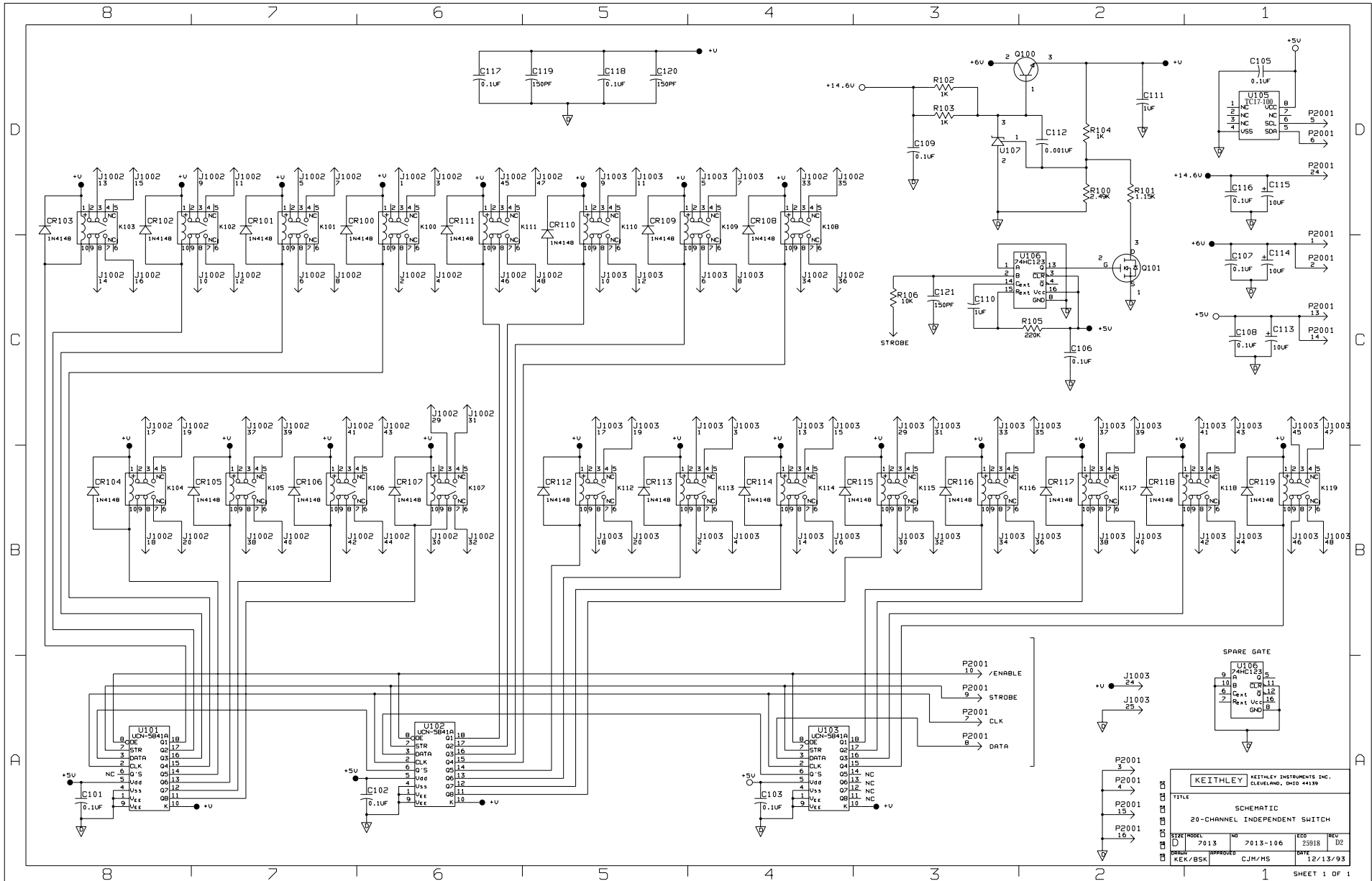

| | |
|--|-----------------------------------|
| KEITHLEY KEITHLEY INSTRUMENTS INC. CLEVELAND, OHIO 44139 | |
| TITLE SCHEMATIC | ECG REV 25918 D2 |
| SIZE MODEL D 7013 | NO 7013-106 |
| DATE 12/13/93 | DESIGNED BY APPROVED CJM/MS |

Table 6-2
Screw terminal board for Model 7013-S, parts list

| Circuit designation | Description | Keithley part number |
|----------------------------|--|--|
| | CABLE CLAMP CAPTIVE SCREW (FOR TOP CLAMP) CONNECTOR SHIM (FOR P1002, 1003) SHIELD STRIP, POLYURETHANE (FOR BOTTOM CLAMP) TOP CLAMP 2-56 × / PHILLIPS PAN HEAD (FOR TERMINAL BOARD SHIELD) | 7011-304-3 FA-243-1 7011-309 2011-305 7011-345-1 7011-302 2-56 × / PPH |
| J1004-1023 | TERMINAL BLOCK | TE-115-4 |
| P1002,1003 | CONNECTOR, FEMALE | CS-748-3 |

Table 6-3
Mass terminated board for Model 7013-C, parts list

| Circuit designation | Description | Keithley part number |
|----------------------------|---|--|
| | BRACKET CONNECTOR SHIM SHIELD STANDOFF | 7011-307 7011-309 7011-311 ST-203-1 |
| J1004 | CONN, 96-PIN, 3 ROWS | CS-514 |
| P1002,P1003 | CONNECTOR, FEMALE | CS-748-3 |

091-2102.DN

| LTR. | ECO NO. | REVISION | ENG. | DATE |
|------|---------|-------------|------|---------|
| B | | PRELIMINARY | | |
| C | 910920 | RELEASED | MS | 9-20-91 |
| D | 15129 | REVISED | | 8-12-93 |

- 7011-302 (TOP CLAMP)
- 7011-304-3 (CLAMP SILKSCREEN)
- 2001-345-1 (POLYURETHANE STRIP)
- FA-243-1 (CAPTIVE PANEL SCREW)

CAUTION:  Max. VOLTAGE
 TERMINAL TO TERMINAL OR CHASSIS:
 110 VDC OR 1.75 VAC PEAK

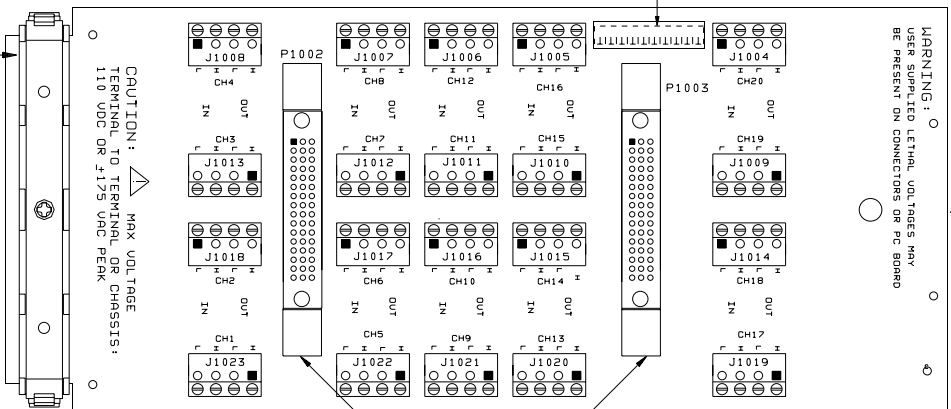

7011-309 (CONNECTOR SHIM)
(2 REQ'D)

NOTE: FOR COMPONENT INFORMATION,
REFER TO PRODUCT STRUCTURE

| MODEL | NEXT ASSEMBLY | QTY. |
|---------|---------------|------|
| | | |
| USED ON | | |

| | | | | |
|---|---|--------------|-----------------------------|--|
| DO NOT SCALE THIS DRAWING | DIMENSIONAL TOLERANCES UNLESS OTHERWISE SPECIFIED | DATE 9/17/91 | SCALE 5:4 | TITLE |
| KEITHLEY KEITHLEY INSTRUMENTS INC. CLEVELAND, OHIO 44139 | XX±.015 ANG.±2° XXX±.005 FRAC.±21/64 SURFACE MAX.  | DRN. KEK | ENG. JMK/CM APPR. JMK/CM | COMPONENT LAYOUT TERMINAL BLOCK BOARD |
| | | | | NO. 7013-160 |

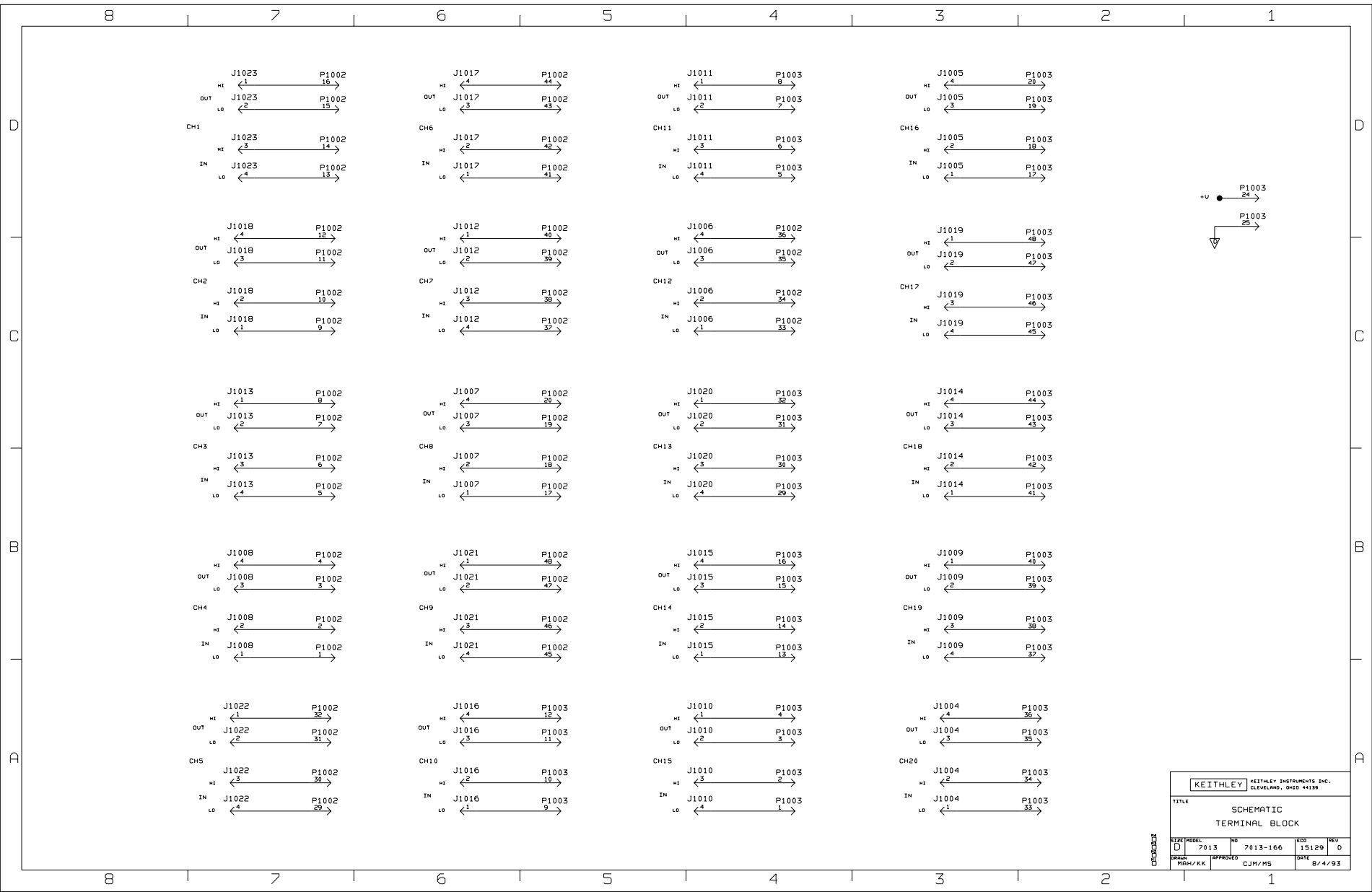

| | | | |
|----------------|----------|---------------------------|-------|
| KEITHLEY | | KEITHLEY INSTRUMENTS INC. | |
| | | CLEVELAND, OHIO 44139 | |
| TITLE | | | |
| SCHEMATIC | | | |
| TERMINAL BLOCK | | | |
| SIZE | MODEL | NO | ECO |
| D | 7013 | 7013-166 | 15129 |
| DRWN | APPROVED | DATE | REV |
| HEHM/KK | CJM/MS | 8/4/93 | 0 |

021-2102 .ON

| LTR. | ECO NO. | REVISION | ENG. | DATE |
|------|---------|----------|------|--------|
| B | 15028 | RELEASED | SZ | 1-2-92 |
| | | | | |
| | | | | |

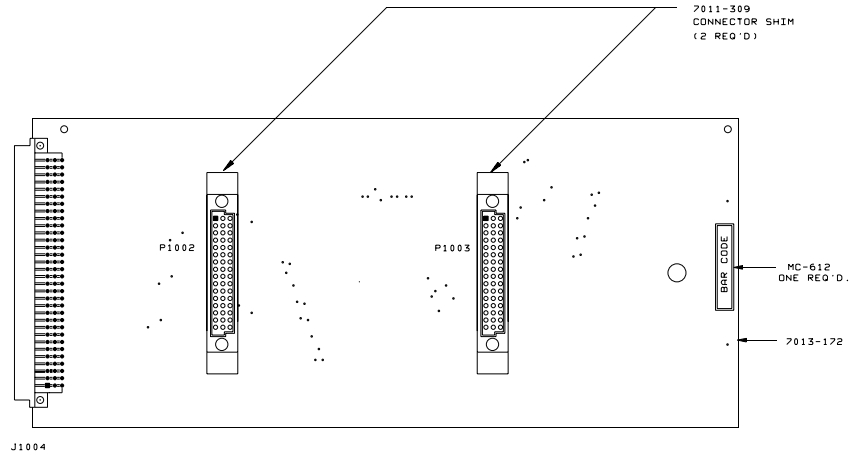

NOTE: FOR COMPONENT INFORMATION
REFER TO PRODUCT STRUCTURE.

| MODEL | NEXT ASSEMBLY | QTY. | USED ON |
|-------|---------------|------|---------|
| 7013 | | | |
| | | | |
| | | | |

| | | | | |
|---|--|---------------|------------|--|
| DO NOT SCALE THIS DRAWING | DIMENSIONAL TOLERANCES UNLESS OTHERWISE SPECIFIED | DATE 12/18/91 | SCALE 1:1 | TITLE |
| KEITHLEY | XX±.015 ANG. ±1° | DRN. MAH | ENG. APPR. | COMPONENT LAYOUT MASS TERMINATION BOARD |
| KEITHLEY INSTRUMENTS INC CLEVELAND, OHIO 44139 | XXX±.005 FRAC. ±1/64 | MATERIAL | | NO. 7013-170 |
| | SURFACE MAX. 63 | FINISH | | |

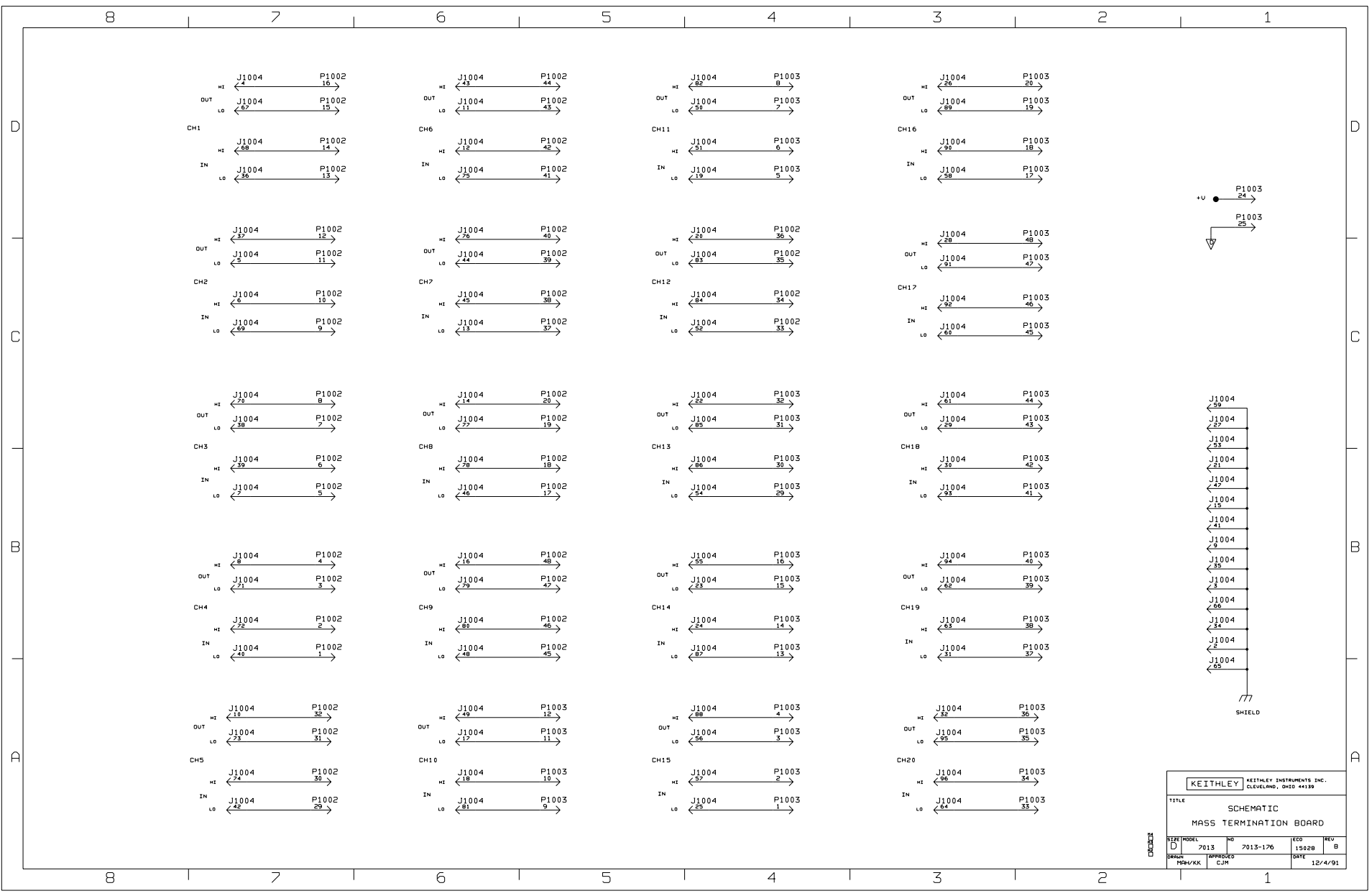

| | | | |
|--|----------|----------|---------|
| KEITHLEY KEITHLEY INSTRUMENTS INC. CLEVELAND, OHIO 44139 | | | |
| TITLE SCHEMATIC BOARD | | | |
| MASS TERMINATION BOARD | | | |
| SIZE | MODEL | NO | REV |
| D | 7013 | 7013-176 | 15028 B |
| DESIGN | APPROVED | DATE | |
| MMH/KK | CJM | 12/4/91 | |

CH20



Service Form

Model No. _____ Serial No. _____ Date _____

Name and Telephone No. _____

Company _____

List all control settings, describe problem and check boxes that apply to problem. _____

- | | | |
|--|--|--|
| <input type="checkbox"/> Intermittent | <input type="checkbox"/> Analog output follows display | <input type="checkbox"/> Particular range or function bad; specify _____ |
| <input type="checkbox"/> IEEE failure | <input type="checkbox"/> Obvious problem on power-up | <input type="checkbox"/> Batteries and fuses are OK |
| <input type="checkbox"/> Front panel operational | <input type="checkbox"/> All ranges or functions are bad | <input type="checkbox"/> Checked all cables |

Display or output (check one)

- | | |
|-----------------------------------|--|
| <input type="checkbox"/> Drifts | <input type="checkbox"/> Unable to zero |
| <input type="checkbox"/> Unstable | <input type="checkbox"/> Will not read applied input |
| <input type="checkbox"/> Overload | |

- | | |
|---|--|
| <input type="checkbox"/> Calibration only | <input type="checkbox"/> Certificate of calibration required |
| <input type="checkbox"/> Data required | |

(attach any additional sheets as necessary)

Show a block diagram of your measurement system including all instruments connected (whether power is turned on or not). Also, describe signal source.

Where is the measurement being performed? (factory, controlled laboratory, out-of-doors, etc.)

What power line voltage is used? _____ Ambient temperature? _____ °F

Relative humidity? _____ Other? _____

Any additional information. (If special modifications have been made by the user, please describe.)

Be sure to include your name and phone number on this service form.



Keithley Instruments, Inc.
28775 Aurora Road
Cleveland, Ohio 44139
Printed in the U.S.A.