Instruction Manual

Model 7035
9-Bank, 1×4 Multiplexer Card

Contains Operating and Servicing Information

KEITHLEY

WARRANTY

Keithley Instruments, Inc. warrants this product to be free from defects in material and workmanship for a period of 1 year from date of shipment.

Keithley Instruments, Inc. warrants the following items for 90 days from the date of shipment: probes, cables, rechargeable batteries, diskettes, and documentation.

During the warranty period, we will, at our option, either repair or replace any product that proves to be defective.

To exercise this warranty, write or call your local Keithley representative, or contact Keithley headquarters in Cleveland, Ohio. You will be given prompt assistance and return instructions. Send the product, transportation prepaid, to the indicated service facility. Repairs will be made and the product returned, transportation prepaid. Repaired or replaced products are warranted for the balance of the original warranty period, or at least 90 days.

LIMITATION OF WARRANTY

This warranty does not apply to defects resulting from product modification without Keithley's express written consent, or misuse of any product or part. This warranty also does not apply to fuses, software, non-rechargeable batteries, damage from battery leakage, or problems arising from normal wear or failure to follow instructions.

THIS WARRANTY IS IN LIEU OF ALL OTHER WARRANTIES, EXPRESSED OR IMPLIED, INCLUDING ANY IMPLIED WARRANTY OF MERCHANTABILITY OR FITNESS FOR A PARTICULAR USE. THE REMEDIES PROVIDED HEREIN ARE BUYER'S SOLE AND EXCLUSIVE REMEDIES.

NEITHER KEITHLEY INSTRUMENTS, INC. NOR ANY OF ITS EMPLOYEES SHALL BE LIABLE FOR ANY DIRECT, INDIRECT, SPECIAL, INCIDENTAL OR CONSEQUENTIAL DAMAGES ARISING OUT OF THE USE OF ITS INSTRUMENTS AND SOFTWARE EVEN IF KEITHLEY INSTRUMENTS, INC., HAS BEEN ADVISED IN ADVANCE OF THE POSSIBILITY OF SUCH DAMAGES. SUCH EXCLUDED DAMAGES SHALL INCLUDE, BUT ARE NOT LIMITED TO: COSTS OF REMOVAL AND INSTALLATION, LOSSES SUSTAINED AS THE RESULT OF INJURY TO ANY PERSON, OR DAMAGE TO PROPERTY.

KEITHLEY

Keithley Instruments, Inc. • 28775 Aurora Road • Cleveland, OH 44139 • 216-248-0400 • Fax: 216-248-6168 • <http://www.keithley.com>

CHINA:	Keithley Instruments China • Yuan Chen Xin Building, Room 705 • 12 Yumin Road, Dewai, Madian • Beijing 100029 • 8610-62022886 • Fax: 8610-62022892
FRANCE:	Keithley Instruments SARL • BP 60 • 3 Allée des Garays • 91122 Palaiseau Cédex • 33-1-60-11-51-55 • Fax: 33-1-60-11-77-26
GERMANY:	Keithley Instruments GmbH • Landsberger Strasse 65 • D-82110 Germering, Munich • 49-89-8493070 • Fax: 49-89-84930759
GREAT BRITAIN:	Keithley Instruments, Ltd. • The Minster • 58 Portman Road • Reading, Berkshire RG30 1EA • 44-118-9575666 • Fax: 44-118-9596469
ITALY:	Keithley Instruments SRL • Viale S. Gimignano 38 • 20146 Milano • 39-2-48303008 • Fax: 39-2-48302274
NETHERLANDS:	Keithley Instruments BV • Avelingen West 49 • 4202 MS Gorinchem • 31-(0)183-635333 • Fax: 31-(0)183-630821
SWITZERLAND:	Keithley Instruments SA • Kriesbachstrasse 4 • 8600 Dübendorf • 41-1-8219444 • Fax: 41-1-8203081
TAIWAN:	Keithley Instruments Taiwan • 1FL., 1, Min Yu First Street • Hsinchu, Taiwan, R.O.C. • 886-35-778462 • Fax: 886-35-778455

Model 7035 9-Bank, 1×4 Multiplexer Card Instruction Manual

©1997, Keithley Instruments, Inc.
All rights reserved.
Cleveland, Ohio, U.S.A.
First Printing, May 1997
Document Number: 7035-901-01 Rev. A

Manual Print History

The print history shown below lists the printing dates of all Revisions and Addenda created for this manual. The Revision Level letter increases alphabetically as the manual undergoes subsequent updates. Addenda, which are released between Revisions, contain important change information that the user should incorporate immediately into the manual. Addenda are numbered sequentially. When a new Revision is created, all Addenda associated with the previous Revision of the manual are incorporated into the new Revision of the manual. Each new Revision includes a revised copy of this print history page.

Many product updates and revisions do not require manual changes and, conversely, manual corrections may be done without accompanying product changes. Therefore, it is recommended that you review the Manual Update History.

Revision A (Document Number 7035-901-01)..... May 1997

Safety Precautions

The following safety precautions should be observed before using this product and any associated instrumentation. Although some instruments and accessories would normally be used with non-hazardous voltages, there are situations where hazardous conditions may be present.

This product is intended for use by qualified personnel who recognize shock hazards and are familiar with the safety precautions required to avoid possible injury. Read the operating information carefully before using the product.

The types of product users are:

Responsible body is the individual or group responsible for the use and maintenance of equipment, and for ensuring that operators are adequately trained.

Operators use the product for its intended function. They must be trained in electrical safety procedures and proper use of the instrument. They must be protected from electric shock and contact with hazardous live circuits.

Maintenance personnel perform routine procedures on the product to keep it operating, for example, setting the line voltage or replacing consumable materials. Maintenance procedures are described in the manual. The procedures explicitly state if the operator may perform them. Otherwise, they should be performed only by service personnel.

Service personnel are trained to work on live circuits, and perform safe installations and repairs of products. Only properly trained service personnel may perform installation and service procedures.

Exercise extreme caution when a shock hazard is present. Lethal voltage may be present on cable connector jacks or test fixtures. The American National Standards Institute (ANSI) states that a shock hazard exists when voltage levels greater than 30V RMS, 42.4V peak, or 60VDC are present. **A good safety practice is to expect that hazardous voltage is present in any unknown circuit before measuring.**

Users of this product must be protected from electric shock at all times. The responsible body must ensure that users are prevented access and/or insulated from every connection point. In some cases, connections must be exposed to potential human contact. Product users in these circumstances must be trained to protect themselves from the risk of electric shock. If the circuit is capable of operating at or above 1000 volts, **no conductive part of the circuit may be exposed.**

As described in the International Electrotechnical Commission (IEC) Standard IEC 664, digital multimeter measuring circuits (e.g., Keithley Models 175A, 199, 2000, 2001, 2002, and 2010) measuring circuits are Installation Category II. All other instruments' signal terminals are Installation Category I and must not be connected to mains.

Do not connect switching cards directly to unlimited power circuits. They are intended to be used with impedance limited sources. NEVER connect switching cards directly to AC mains. When connecting sources to switching cards, install protective devices to limit fault current and voltage to the card.

Before operating an instrument, make sure the line cord is connected to a properly grounded power receptacle. Inspect the connecting cables, test leads, and jumpers for possible wear, cracks, or breaks before each use.

For maximum safety, do not touch the product, test cables, or any other instruments while power is applied to the circuit under test. ALWAYS remove power from the entire test system and discharge any capacitors before: connecting or disconnecting cables or jumpers, installing or removing switching cards, or making internal changes, such as installing or removing jumpers.

Do not touch any object that could provide a current path to the common side of the circuit under test or power line (earth) ground. Always make measurements with dry hands while standing on a dry, insulated surface capable of withstanding the voltage being measured.

Do not exceed the maximum signal levels of the instruments and accessories, as defined in the specifications and operating information, and as shown on the instrument or test fixture panels, or switching card.

When fuses are used in a product, replace with same type and rating for continued protection against fire hazard.

Chassis connections must only be used as shield connections for measuring circuits, NOT as safety earth ground connections.

If you are using a test fixture, keep the lid closed while power is applied to the device under test. Safe operation requires the use of a lid interlock.

If a  screw is present, connect it to safety earth ground using the wire recommended in the user documentation.

The  symbol on an instrument indicates that the user should refer to the operating instructions located in the manual.

The  symbol on an instrument shows that it can source or measure 1000 volts or more, including the combined effect of normal and common mode voltages. Use standard safety precautions to avoid personal contact with these voltages.

The **WARNING** heading in a manual explains dangers that might result in personal injury or death. Always read the associated information very carefully before performing the indicated procedure.

The **CAUTION** heading in a manual explains hazards that could damage the instrument. Such damage may invalidate the warranty.

Instrumentation and accessories shall not be connected to humans.

Before performing any maintenance, disconnect the line cord and all test cables.

To maintain protection from electric shock and fire, replacement components in mains circuits, including the power transformer, test leads, and input jacks, must be purchased from Keithley Instruments. Standard fuses, with applicable national safety approvals, may be used if the rating and type are the same. Other components that are not safety related may be purchased from other suppliers as long as they are equivalent to the original component. (Note that selected parts should be purchased only through Keithley Instruments to maintain accuracy and functionality of the product.) If you are unsure about the applicability of a replacement component, call a Keithley Instruments office for information.

To clean the instrument, use a damp cloth or mild, water based cleaner. Clean the exterior of the instrument only. Do not apply cleaner directly to the instrument or allow liquids to enter or spill on the instrument.

MODEL 7035 SPECIFICATIONS

MULTIPLEX CONFIGURATION: Nine independent 1×4 2-pole multiplex banks.

CONTACT CONFIGURATION: 2-pole Form A (Hi, Lo).

CONNECTOR TYPE: 96-pin male DIN connector.

MAXIMUM SIGNAL LEVEL: 60VDC, 30V rms, 42V peak between any two inputs or chassis, 1A switched. 30VA (resistive load).

CONTACT LIFE: **Cold Switching:** 10^8 closures.
At Maximum Signal Levels: 10^5 closures.

CHANNEL RESISTANCE (per conductor): $<1\Omega$.

CONTACT POTENTIAL: $<1\mu\text{V}$ per channel contact pair
 $<3\mu\text{V}$ typical per single contact.

OFFSET CURRENT: $<100\text{pA}$.

ACTUATION TIME: 3ms.

ISOLATION: **Bank:** $>10^9\Omega$, $<25\text{pF}$
Channel to Channel: $>10^9\Omega$, $<50\text{pF}$
Differential: $>10^9\Omega$, $<100\text{pF}$
Common Mode: $>10^9\Omega$, $<200\text{pF}$

CROSSTALK (1MHz, 50Ω Load): **Bank:** $<-40\text{dB}$.
Channel: $<-40\text{dB}$.

INSERTION LOSS (50Ω Source, 50 Load): $<0.25\text{dB}$ below 1MHz,
 $<3\text{dB}$ below 10MHz.

RELAY DRIVE CURRENT (per relay): 16mA.

ENVIRONMENT: Operating: 0° to 50°C , up to 35°C $<80\%$ RH.
Storage: -25°C to 65°C .

EMC: Conforms with European Union Directive 89/336/EEC
EN 55011, EN 50082-1, EN 61000-3-2 and 61000-3-3, FCC part 15 class B.

SAFETY: Conforms with European Union Directive 73/23/EEC
EN 61010-1, UL 3111-1.

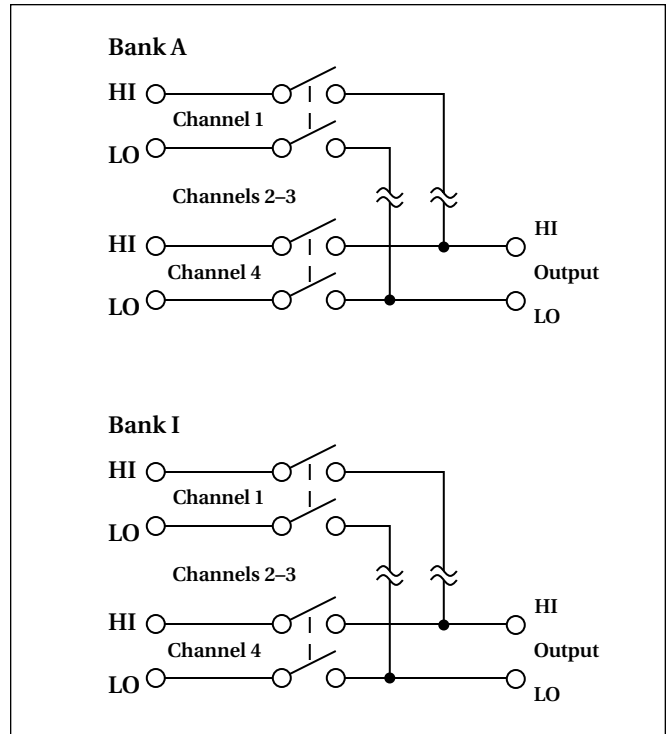

Specifications are subject to change without notice.

Table of Contents

1 General Information

Introduction	1-1
Features	1-1
Warranty information	1-1
Manual addenda	1-2
Safety symbols and terms	1-2
Specifications	1-2
Unpacking and inspection	1-2
Inspection for damage	1-2
Handling precautions	1-2
Shipping contents	1-2
Instruction manual	1-2
Repacking for shipment	1-3
Optional accessories	1-3

2 Multiplexer Configuration

Introduction	2-1
Basic multiplexer configuration	2-1
Typical multiplexer switching schemes	2-2
Single-ended switching	2-2
Differential switching	2-2
Sensing	2-3
SMU connections	2-3
Multiplexer expansion	2-4

3 Card Connections and Installation

Introduction	3-1
Handling precautions	3-1
Multi-pin (mass termination) connections.....	3-1
Typical connection technique.....	3-4
Typical connection scheme	3-6
Model 7035 installation and removal	3-8
Card installation.....	3-8
Card removal	3-8

4 Operation

Introduction	4-1
Power limits.....	4-1
Maximum signal levels.....	4-1
Mainframe control of card.....	4-1
Channel assignments	4-2
Closing and opening channels	4-4
Scanning channels	4-4
IEEE-488 bus operation	4-5
Multiplexer switching examples.....	4-6
Two-wire resistance tests	4-6
Four-wire resistance tests	4-7
Measurement considerations	4-7
Path isolation	4-7
Magnetic fields	4-8
Radio frequency interference	4-8
Ground loops	4-9
Keeping connectors clean.....	4-9
AC frequency response.....	4-9

5 Service Information

Introduction	5-1
Handling and cleaning precautions	5-1
Performance verification	5-2
Environmental conditions.....	5-2
Recommended equipment	5-2
Multiplexer connections	5-2
Channel resistance tests.....	5-3
Offset current tests.....	5-4
Contact potential tests.....	5-6
Bank and channel-to-channel isolation tests	5-8
Differential and common-mode isolation tests.....	5-12
Special handling of static-sensitive devices	5-16
Principles of operation.....	5-16
Block diagram	5-16
ID data circuits	5-17
Relay control	5-17
Relay power control	5-17

Power-on safeguard.....	5-18
Troubleshooting	5-18
Troubleshooting equipment	5-18
Troubleshooting access	5-18
Troubleshooting procedure	5-18

6 Replaceable Parts

Introduction.....	6-1
Parts lists	6-1
Ordering information	6-1
Factory service	6-1
Component layouts and schematic diagrams	6-1

Index

List of Illustrations

2 Multiplexer Configuration

Figure 2-1	Model 7035 simplified schematic	2-1
Figure 2-2	Single-ended switching example.....	2-2
Figure 2-3	Differential switching example.....	2-2
Figure 2-4	Sensing example	2-3
Figure 2-5	SMU connections	2-3
Figure 2-6	Multiplexer expansion example	2-4

3 Card Connections and Installation

Figure 3-1	Multi-pin connector card terminal identification	3-2
Figure 3-2	Typical round cable connection techniques	3-4
Figure 3-3	Model 7011-MTR connector pinout	3-5
Figure 3-4	Model 7011-KIT-R (cable) assembly	3-5
Figure 3-5	Typical connection scheme for Model 7035	3-7
Figure 3-6	Model 7035 card installation in Model 7001	3-8

4 Operation

Figure 4-1	Model 7001 channel status display	4-2
Figure 4-2	Model 7002 channel status display (slot 1).....	4-2
Figure 4-3	Display organization for multiplexer channels	4-3
Figure 4-4	Channel assignments.....	4-3
Figure 4-5	Two-wire resistance testing.....	4-6
Figure 4-6	1x36 multiplex bank.....	4-6
Figure 4-7	Four-wire resistance testing	4-7
Figure 4-8	Path isolation resistance	4-8
Figure 4-9	Voltage attenuation by path isolation resistance	4-8
Figure 4-10	Power line ground loops	4-9
Figure 4-11	Eliminating ground loops	4-9

5

Service Information

Figure 5-1	Path resistance test connections.....	5-3
Figure 5-2	Differential offset current test connections	5-5
Figure 5-3	Contact potential test connections	5-7
Figure 5-4	Bank isolation test connections	5-8
Figure 5-5	Channel-to-channel isolation test connections	5-10
Figure 5-6	Differential isolation test connections	5-13
Figure 5-7	Common-mode isolation test connections.....	5-15
Figure 5-8	Model 7035 block diagram.....	5-16
Figure 5-9	Start and stop sequences.....	5-17
Figure 5-10	Transmit and acknowledge sequence	5-17

List of Tables

3 Card Connections and Installation

Table 3-1	Multi-pin connector card terminal designation cross-reference.....	3-3
Table 3-2	Mass termination accessories.....	3-3

4 Operation

Table 4-1	Paired channels in four-wire resistance example.....	4-7
-----------	------------------------------------------------------	-----

5 Service Information

Table 5-1	Verification equipment	5-2
Table 5-2	Bank isolation test summary	5-9
Table 5-3	Channel-to-channel isolation test summary	5-11
Table 5-4	Differential and common-mode isolation testing.....	5-14
Table 5-5	Recommended troubleshooting equipment.....	5-18
Table 5-6	Troubleshooting procedure	5-19

6 Replaceable Parts

Table 6-1	Relay board for Model 7035 parts list	6-2
Table 6-2	Mass-terminated connector board for Model 7035 parts list	6-3
Table 6-3	Model 7011-KIT-R 96-pin female DIN connector kit parts list	6-3

1

General Information

Introduction

This section contains general information about the Model 7035 9-Bank, 1×4 Multiplexer Card.

The Model 7035 assembly consists of a multi-pin (mass termination) connector card and a relay card. External test circuit connections to the Model 7035 are made via the 96-pin male DIN connector on the connector card. Keithley offers a variety of optional accessories that can be used to make connections to the connector card. See the available optional accessories at the end of this section.

The rest of Section 1 is arranged in the following manner:

- **Features**
- **Warranty information**
- **Manual addenda**
- **Safety symbols and terms**
- **Specifications**
- **Unpacking and inspection**
- **Repacking for shipment**
- **Optional accessories**

Features

The Model 7035 is a general purpose multiplexer card with nine independent, 1×4, two-pole, multiplex banks. Some of the key features include:

- Low contact potential and offset current for minimal effects on low-level signals.
- High isolation resistance ($>1G\Omega$) for minimal load effects.
- Model 7011-KIT-R connector kit that includes a 96-pin female DIN connector that will mate directly to the connector on the Model 7035 or to a standard 96-pin male DIN bulkhead connector (see Model 7011-MTR). This connector uses solder cups for connections to external circuitry and includes an adapter for a round cable and the housing.

Warranty information

Warranty information is located at the front of this instruction manual. Should your Model 7035 require warranty service, contact the Keithley representative or authorized repair facility in your area for further information. When returning the card for repair, be sure to fill out and include the service form at the back of this manual in order to provide the repair facility with the necessary information.

Manual addenda

Any improvements or changes concerning the card or manual will be explained in an addendum included with the card. Addenda are provided in a page-replacement format. Replace the obsolete pages with the new pages.

Safety symbols and terms

The following symbols and terms may be found on an instrument or used in this manual.

The  symbol on an instrument indicates that you should refer to the operating instructions located in the instruction manual.

The  symbol on an instrument shows that high voltage may be present on the terminal(s). Use standard safety precautions to avoid personal contact with these voltages.

The **WARNING** heading used in this manual explains dangers that might result in personal injury or death. Always read the associated information very carefully before performing the indicated procedure.

The **CAUTION** heading used in this manual explains hazards that could damage the card. Such damage may invalidate the warranty.

Specifications

Model 7035 specifications may be found at the front of this manual. These specifications are exclusive of the Model 7001/7002 mainframe specifications.

Unpacking and inspection

Inspection for damage

The Model 7035 is packaged in a resealable, anti-static bag to protect it from damage due to static discharge and from

contamination that could degrade its performance. Before removing the card from the bag, observe the following precautions on handling.

Handling precautions

1. Always grasp the card by the side edges and shields. Do not touch the board surfaces or components.
2. When not installed in a Model 7001/7002 mainframe, keep the card in the anti-static bag and store it in the original packing carton.

After removing the card from its anti-static bag, inspect it for any obvious signs of physical damage. Report any such damage to the shipping agent immediately.

Shipping contents

The following items are included with every Model 7035 order:

- Model 7035 9-Bank, 1×4 Multiplexer Card
- Model 7011-KIT-R 96-pin Female DIN Connector Kit
- Model 7035 Instruction Manual
- Additional accessories as ordered

Instruction manual

The Model 7035 Instruction Manual is three-hole drilled so it can be added to the three-ring binder of the Model 7001 or Model 7002 Instruction Manual. After removing the plastic wrapping, place the manual in the binder following the mainframe instruction manual. Note that a manual identification tab is included and should precede the multiplexer card instruction manual.

If an additional instruction manual is required, order the manual package, Keithley part number 7035-901-00. The manual package includes an instruction manual and any pertinent addenda.

Repacking for shipment

Should it become necessary to return the Model 7035 for repair, carefully pack the unit in its original packing carton, or the equivalent, and include the following information:

- Advise as to the warranty status of the card.
- Write ATTENTION REPAIR DEPARTMENT on the shipping label.
- Fill out and include the service form located at the back of this manual.

Optional accessories

The following accessories are available for use with the Model 7035:

Model 7011-MTC-2 — This two-meter round cable assembly is terminated with a 96-pin female DIN connector on each end. It will mate directly to the connector on the Model 7035 and to a standard 96-pin male DIN bulkhead connector (see Model 7011-MTR).

Model 7011-MTR — This 96-pin male DIN bulkhead connector uses solder cups for connections to external circuitry. It will mate to the Model 7011-KIT-R connector and Model 7011-MTC-2 cable assembly.

2

Multiplexer Configuration

Introduction

This section covers the basics for multiplexer switching and is arranged as follows:

- **Basic multiplexer configuration** — Covers the basic multiplexer configuration.
- **Typical multiplexer switching schemes** — Explains some of the basic ways a multiplexer can be used to source or measure. Covers single-ended switching, differential (floating) switching, sensing, and SMU connections.
- **Multiplexer expansion** — Discusses how to configure a larger multiplexer configuration.

Basic multiplexer configuration

A simplified schematic of the Model 7035 multiplex banks is shown in Figure 2-1. It is organized as nine independent 1×4 banks. Each bank has four inputs and one output. Two-pole switching is provided for each multiplexer input, with HI and LO switched.

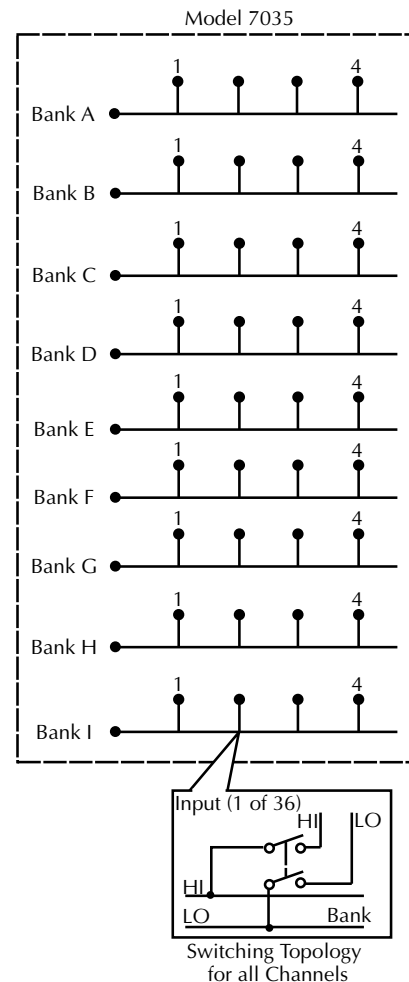

Figure 2-1
Model 7035 simplified schematic

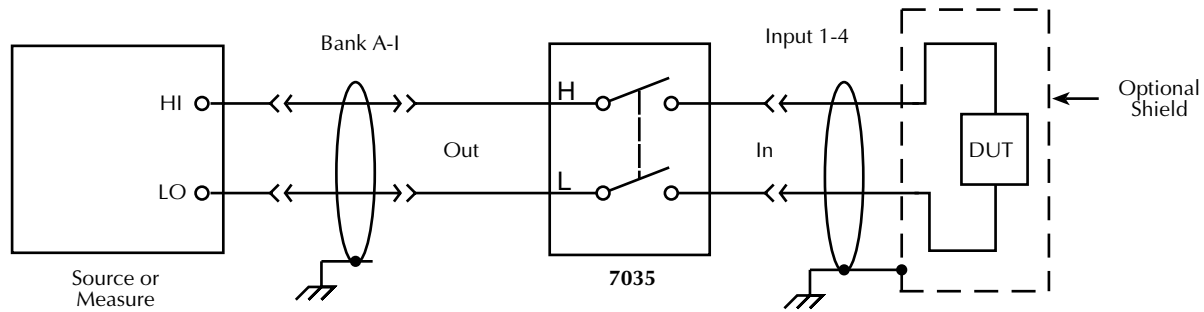

Figure 2-2
Single-ended switching example

Typical multiplexer switching schemes

The following paragraphs describe some basic switching schemes that are possible with a two-pole switching multiplexer. These switching schemes include some various shielding configurations to help minimize noise pick-up in sensitive measurement applications. These shields are shown connected to chassis ground. For some test configurations, shielding may prove to be more effective connected to circuit common. Chassis ground is accessible at the rear panel of the Model 7001/7002 mainframe.

single pathway as shown in Figure 2-2. The instrument is connected to the output of one of the banks, and the DUT is shown connected to one of the inputs for that bank.

Differential switching

The differential or floating switching configuration is shown in Figure 2-3. The advantage of using this configuration is that the terminals of the source or measure instrument are not confined to the same pathway. Each terminal of the instrument can be switched to any available input in the test system.

Single-ended switching

In the single-ended switching configuration, the source or measure instrument is connected to the DUT through a

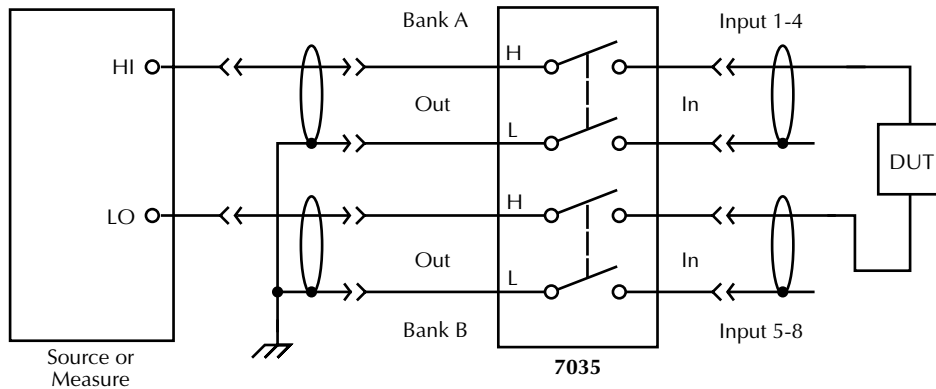

Figure 2-3
Differential switching example

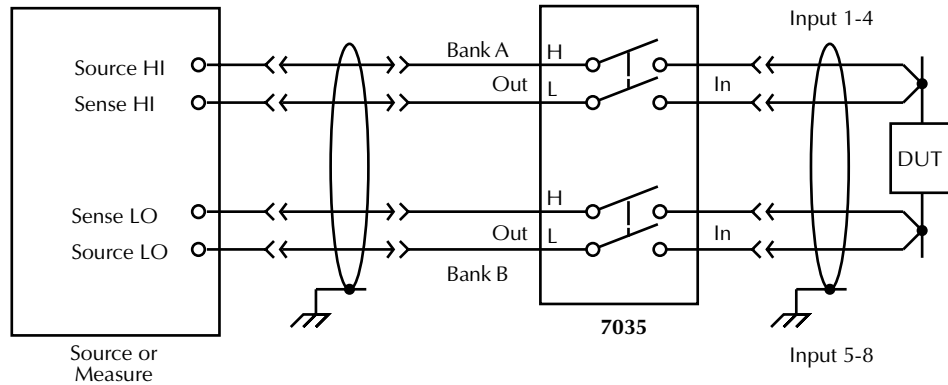

Figure 2-4
Sensing example

Sensing

Figure 2-4 shows how the multiplexer can be configured to use instruments that have sensing capability. The main advantage of using sensing is to cancel the effects of switch card path resistance ($<1\Omega$) and the resistance of external cabling. Whenever path resistance is a consideration, sensing should be used.

SMU connections

Figure 2-5 shows how to connect a Keithley Model 236, 237, or 238 Source Measure Unit to the multiplexer. By using triax cables that are unterminated at one end, the driven guard and chassis ground are physically extended all the way to the card.

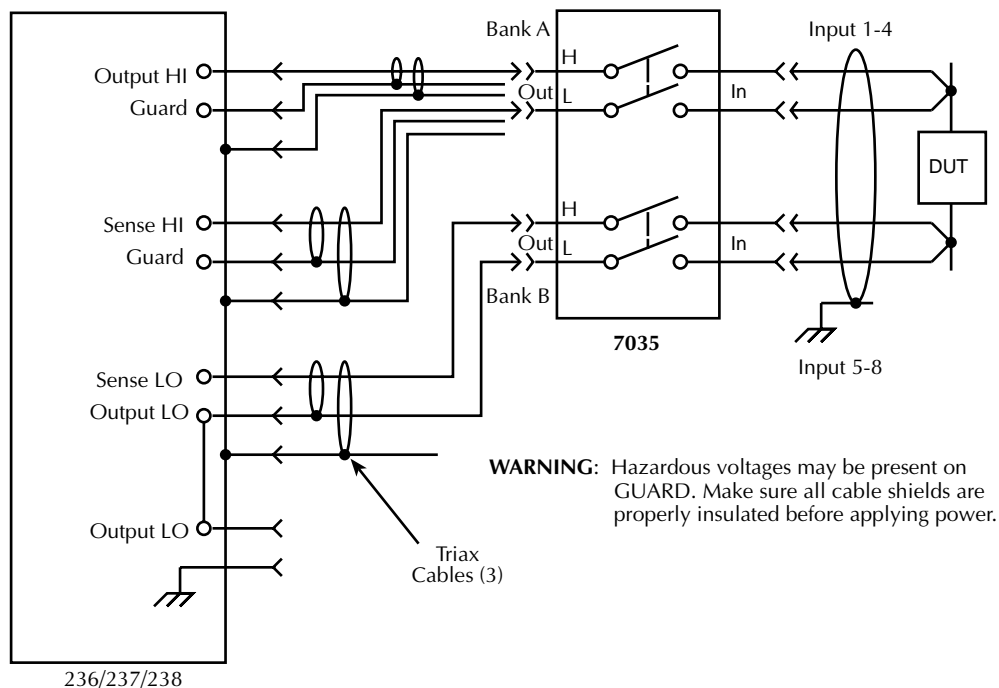

Figure 2-5
SMU connections

Multiplexer expansion

Larger multiplexers can be configured by externally connecting the individual Model 7035 multiplex banks using customer-supplied external jumpers. You can configure a multiplexer as large as 1×36 (Figure 2-6).

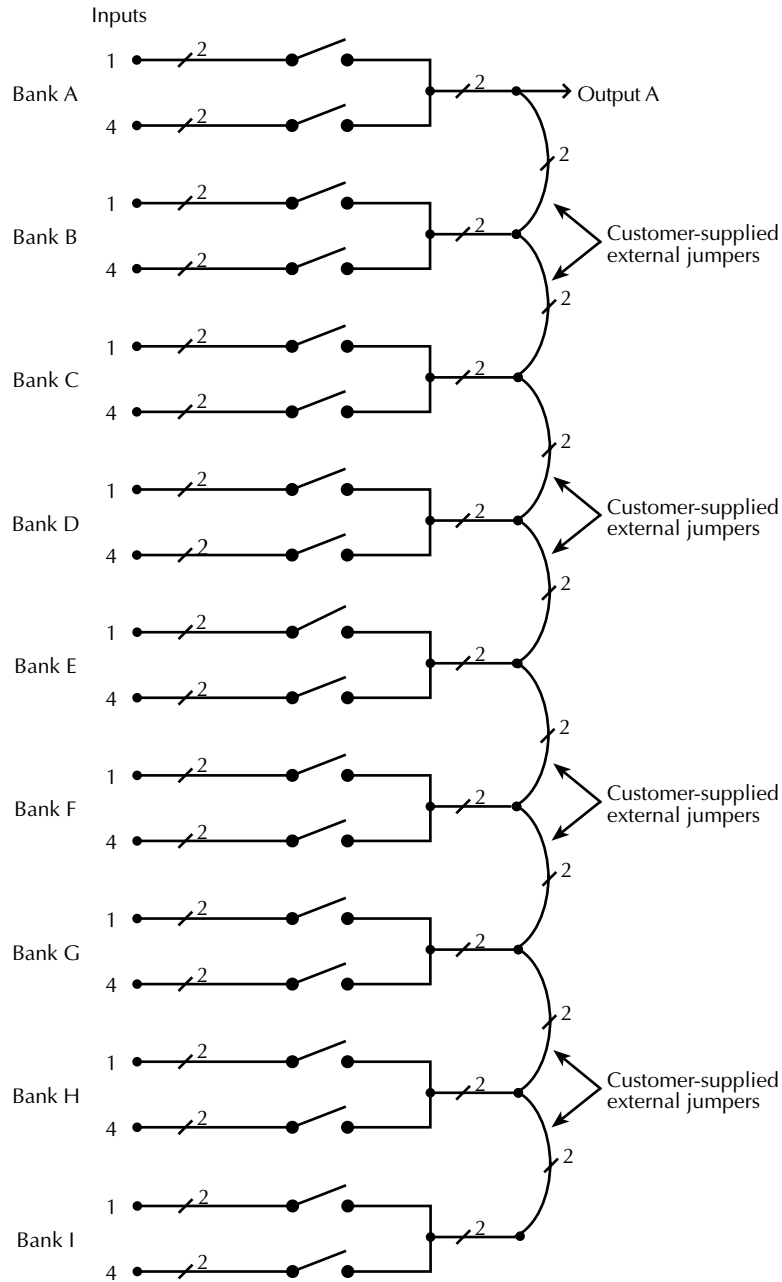

Figure 2-6
Multiplexer expansion example

3

Card Connections and Installation

Introduction

WARNING

The procedures in this section are intended only for qualified service personnel. Do not perform these procedures unless qualified to do so. Failure to recognize and observe normal safety precautions could result in personal injury or death.

The information in this section is arranged as follows:

- **Handling precautions** — Explains precautions that must be followed to prevent contamination to the card assembly. Contamination could degrade the performance of the card.
- **Multi-pin (mass termination) connections** — Covers the basics for connecting external circuitry to the connector card.
- **Model 7035 installation and removal** — Provides the procedure to install and remove the card assembly from the Model 7001/7002 mainframe.

Handling precautions

To maintain high impedance isolation, take care when handling the card to avoid contamination from such foreign materials as body oils. Such contamination can substantially lower leakage resistances and degrade performance.

To avoid possible contamination, always grasp the relay card and the connector card by the side edges or shields. Do not touch the board surfaces or components. On connectors, do not touch areas adjacent to the electrical contacts. Dirt buildup over a period of time is another possible source of contamination. To avoid this problem, operate the mainframe and card assembly in a clean environment.

If a card becomes contaminated, it should be thoroughly cleaned as explained in Section 5.

Multi-pin (mass termination) connections

Since connections to external circuitry are made at the 96-pin male DIN bulkhead connector, there is no need to separate the connector card from the relay card. If the connector card is separated from the relay card, carefully mate them together and install the supplied 4-40 screw to secure the cards. Make sure to handle the cards by the edges and shields to avoid contamination.

The connector will mate to a 96-pin female DIN connector. Terminal identification for the DIN connector of the multi-pin connector card is provided by Figure 3-1 and Table 3-1 and can be identified in one of three ways:

1. Mux terminal consisting of banks A-I, channels 1-36.
2. Connector description consisting of rows a-c, pins 1-32.
3. Schematic and component layout designation consisting of pins 1-96.

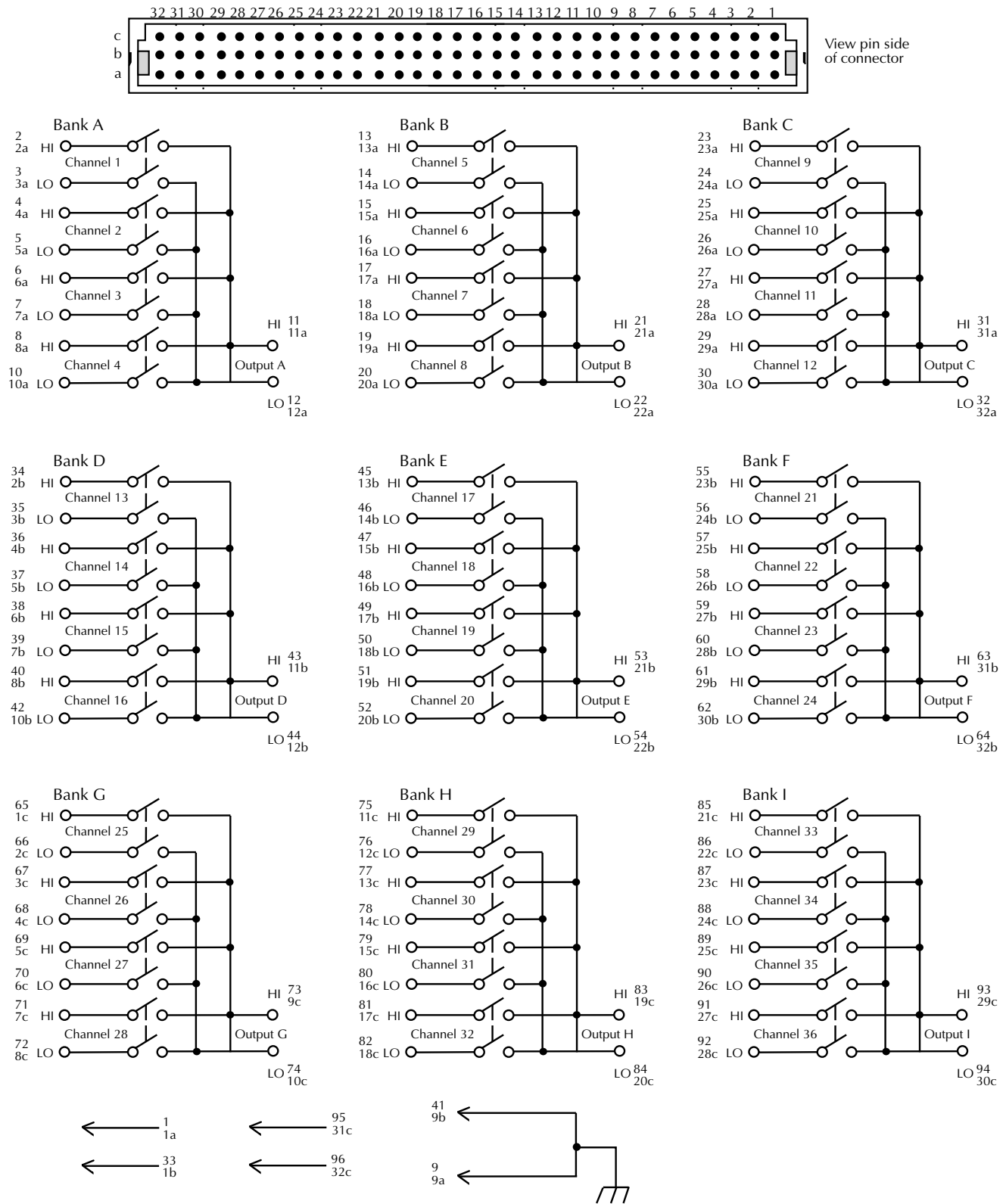

Figure 3-1
Multi-pin connector card terminal identification

Table 3-1
Multi-pin connector card terminal designation cross-reference

Mux terminal	Conn. desig. 1a-32c	Schem. desig. 1-96	Mux terminal	Conn. desig. 1a-32c	Schem. desig. 1-96	Mux terminal	Conn. desig. 1a-32c	Schem. desig. 1-96			
Bank A	Chan 1, HI	2a	2	Bank B	Chan 5, HI	13a	13	Bank C	Chan 9, HI	23a	23
	Chan 1, LO	3a	3		Chan 5, LO	14a	14		Chan 9, LO	24a	24
	Chan 2, HI	4a	4		Chan 6, HI	15a	15		Chan 10, HI	25a	25
	Chan 2, LO	5a	5		Chan 6, LO	16a	16		Chan 10, LO	26a	26
	Chan 3, HI	6a	6		Chan 7, HI	17a	17		Chan 11, HI	27a	27
	Chan 3, LO	7a	7		Chan 7, LO	18a	18		Chan 11, LO	28a	28
	Chan 4, HI	8a	8		Chan 8, HI	19a	19		Chan 12, HI	29a	29
	Chan 4, LO	10a	10		Chan 8, LO	20a	20		Chan 12, LO	30a	30
	Output A, HI	11a	11		Output B, HI	21a	21		Output C, HI	31a	31
	Output A, LO	12a	12		Output B, LO	22a	22		Output C, LO	32a	32
Bank D	Chan 13, HI	2b	34	Bank E	Chan 17, HI	13b	45	Bank F	Chan 21, HI	23b	55
	Chan 13, LO	3b	35		Chan 17, LO	14b	46		Chan 21, LO	24b	56
	Chan 14, HI	4b	36		Chan 18, HI	15b	47		Chan 22, HI	25b	57
	Chan 14, LO	5b	37		Chan 18, LO	16b	48		Chan 22, LO	26b	58
	Chan 15, HI	6b	38		Chan 19, HI	17b	49		Chan 23, HI	27b	59
	Chan 15, LO	7b	39		Chan 19, LO	18b	50		Chan 23, LO	28b	60
	Chan 16, HI	8b	40		Chan 20, HI	19b	51		Chan 24, HI	29b	61
	Chan 16, LO	10b	42		Chan 20, LO	20b	52		Chan 24, LO	30b	62
	Output D, HI	11b	43		Output E, HI	21b	53		Output F, HI	31b	63
	Output D, LO	12b	44		Output E, LO	22b	54		Output F, LO	32b	64
Bank G	Chan 25, HI	1c	65	Bank H	Chan 29, HI	11c	75	Bank I	Chan 33, HI	21c	85
	Chan 25, LO	2c	66		Chan 29, LO	12c	76		Chan 33, LO	22c	86
	Chan 26, HI	3c	67		Chan 30, HI	13c	77		Chan 34, HI	23c	87
	Chan 26, LO	4c	68		Chan 30, LO	14c	78		Chan 34, LO	24c	88
	Chan 27, HI	5c	69		Chan 31, HI	15c	79		Chan 35, HI	25c	89
	Chan 27, LO	6c	70		Chan 31, LO	16c	80		Chan 35, LO	26c	90
	Chan 28, HI	7c	71		Chan 32, HI	17c	81		Chan 36, HI	27c	91
	Chan 28, LO	8c	72		Chan 32, LO	18c	82		Chan 36, LO	28c	92
	Output G, HI	9c	73		Output H, HI	19c	83		Output I, HI	29c	93
	Output G, LO	10c	74		Output H, LO	20c	84		Output I, LO	30c	94
Shield		9a	9	Not Used		1a	1	Not Used		31c	95
Shield		9b	41	Not Used		1b	33	Not Used		32c	96

Keithley has a variety of cable and connector accessories available to accommodate connections from the connector card to test instrumentation and DUTs (devices under test). In general, these accessories, which are summarized in Table 3-2, utilize a round cable assembly for connections.

Table 3-2
Mass termination accessories

Model	Description
7011-KIT-R	96-pin female DIN connector and housing for round cable (provided with the Model 7035 card).
7011-MTC-2	Two-meter round cable assembly terminated with a 96-pin female DIN connector on each end.
7011-MTR	96-pin male DIN bulkhead connector.

Typical connection technique

All external circuitry, such as instrumentation and DUTs, that you want to connect to the card must be terminated with a single 96-pin female DIN connector. The following connection techniques provide some guidelines and suggestions for wiring your circuitry.

WARNING

Before beginning any wiring procedures, make sure all power is off and stored energy in external circuitry is discharged.

WARNING

When wiring a connector and device under test, do not leave any exposed wires or connections. No conductive part of the circuit may be exposed. Properly cover the conductive parts and ensure maximum signal levels are not exceeded or death by electric shock may occur.

NOTE

It is recommended that external circuitry be connected (plugged in) after the Model 7035 assembly is installed in the Model 7001/7002 mainframe. Installation is covered at the end of this section.

Round cable assemblies — shows typical round cable connection techniques using accessories available from Keithley.

In Figure 3-2A, connections are accomplished using a Model 7011-MTC-2 cable and a Model 7011-MTR bulkhead connector. The two-meter round cable is terminated with a 96-pin female DIN connector at each end. This cable mates directly to the multi-pin connector card and to the bulkhead connector. The bulkhead connector has solder cups to allow direct connection to the instrumentation and DUT. Figure 3-3 provides the pinout for the bulkhead connector.

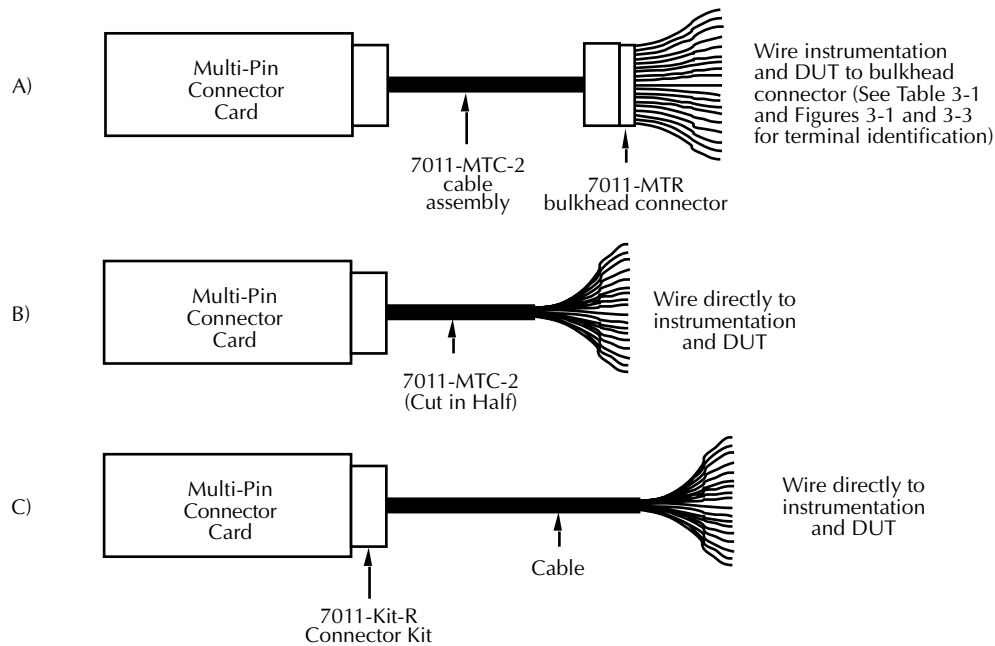

Notes: Figure 3-4 provides an exploded view showing how the connector (with cable) is assembled.

Cable Hitachi p/n N2807-P/D-50TAB is a 50-conductor cable. Two of these cables can be used to supply 100 conductors.

Figure 3-2
Typical round cable connection techniques

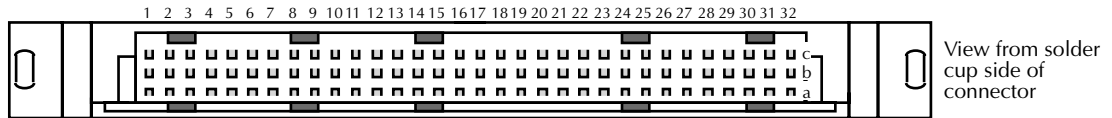

Note: See Figure 3-1 and Table 3-1 for terminal identification.

Figure 3-3
Model 7011-MTR connector pinout

In Figure 3-2B, connections are accomplished using a Model 7011-MTC-2 cable assembly that is cut in half. The 96-pin female DIN connector on one end of the cable mates directly to the multi-pin connector card. The unterminated end of the cable is wired directly to the instrumentation and DUT. The other half of the cable assembly could be used for a second card.

In Figure 3-2C, connections are accomplished using a custom-built cable assembly that consists of a Model 7011-KIT-R connector and a suitable round cable. Hitachi cable part number N2807-P/D-50TAB is a 50-conductor cable. Two of these cables can be used to supply 100 conductors. The connector has solder cups to accommodate the individual wires of the unterminated cable. Figure 3-4 provides an exploded view of the connector assembly and shows how the cable is connected. For further Model 7011-KIT-R assembly information, refer to the packing list provided with the kit. The connector end of the resultant cable assembly mates directly to the multi-pin connector card. The unterminated end of the cable assembly is wired directly to the instrumentation and DUT.

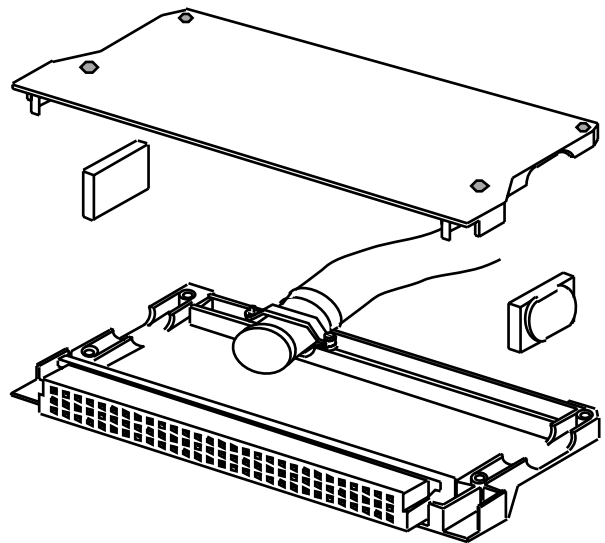

Figure 3-4
Model 7011-KIT-R (cable) assembly

Typical connection scheme

The following information provides a typical connection scheme for the Model 7035. Keep in mind that this is only an example to demonstrate wiring a test system.

Figure 3-5 shows how external connections can be made to the system. Instrumentation and DUTs are hard-wired to the Model 7011-MTR male bulkhead connector. This connector has solder cups that will accept wire size up to #24 AWG. The test system is connected to the Model 7035 multiplexer

using the Model 7011-MTC-2 round cable assembly. This cable mates directly to both the external bulkhead connector and the Model 7035 card. Notice that the bulkhead connector is shown mounted to a fixture to help keep the cabling stable during the test. Connection details are provided in the Multi-pin (mass termination) connections paragraph.

If adding more Model 7035 cards to a system, simply wire them in the same manner as the first. Remember that Model 7035 cards installed in the same mainframe are electrically isolated from each other.

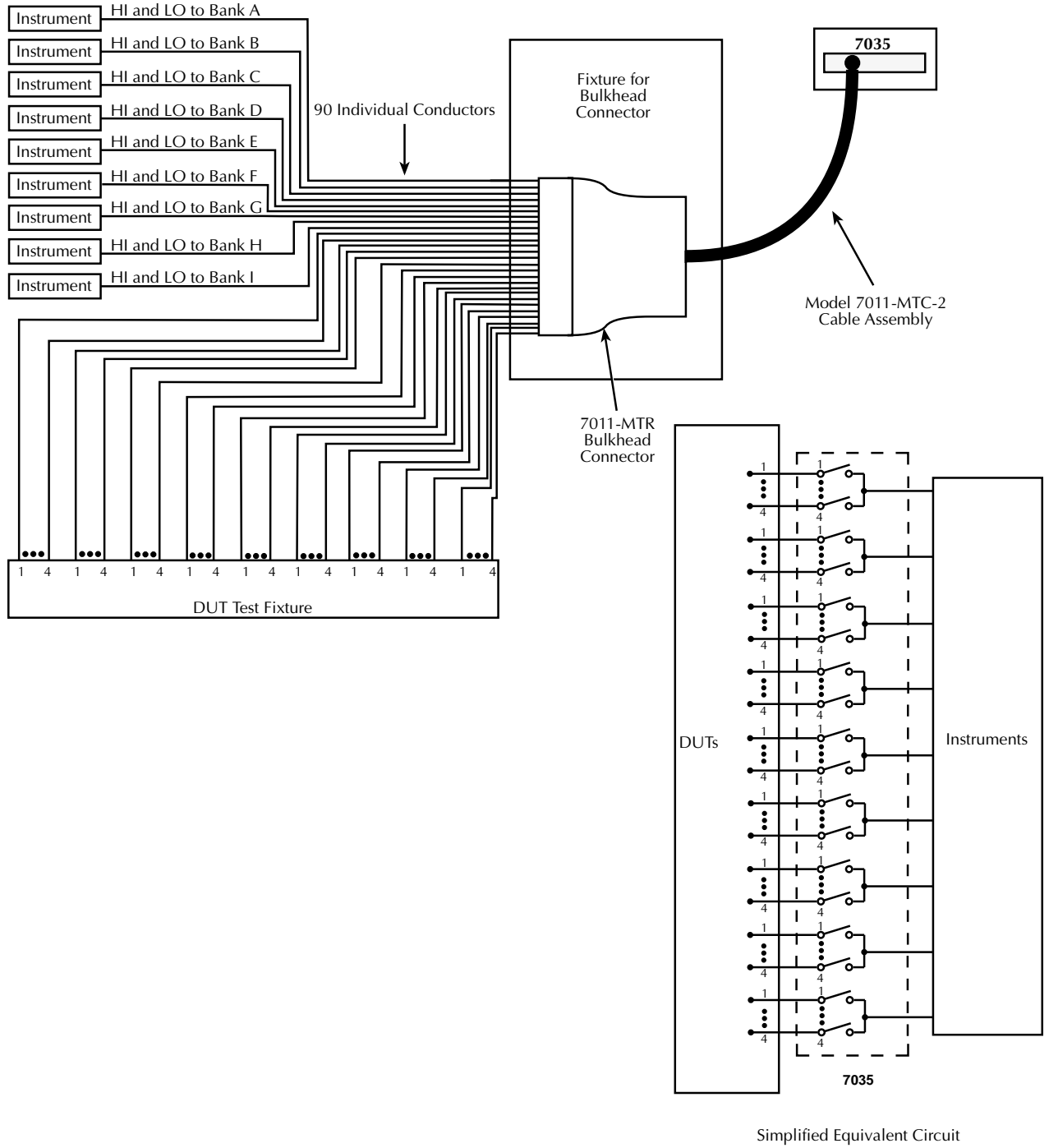

Figure 3-5
Typical connection scheme for Model 7035

Model 7035 installation and removal

The following paragraphs explain how to install and remove the Model 7035 card from the Model 7001/7002 mainframe.

WARNING

Installation or removal of the Model 7035 is to be performed by qualified service personnel. Failure to recognize and observe standard safety precautions could result in personal injury or death.

CAUTION

To prevent contamination to the card that could degrade performance, only handle the card by the edges and shields.

Card installation

Perform the following steps to install the Model 7035 card in the Model 7001/7002 mainframe:

WARNING

Turn off power from all instrumentation (including the Model 7001/7002 mainframe) and disconnect their line cords. Make sure all power is removed and any stored energy in external circuitry is discharged.

1. Mate the connector card to the relay card if they are separated. Install the supplied 4-40 screw to secure the assembly. Make sure to handle the cards by the edges and shields to prevent contamination.
2. Facing the rear panel of the Model 7001/7002, select the slot that you wish to install the Model 7035 card in.
3. Referring to Figure 3-6, feed the Model 7035 card into the desired slot so the edges of the relay card ride in the rails.
4. With the ejector arms in the unlocked position, push the Model 7035 card all the way into the mainframe until the arms engage into the ejector cups. Then push both arms inward to lock the card into the mainframe.

WARNING

To avoid electric shock that could result in injury or death, make sure to properly install and tighten the safety ground screw shown in Figure 3-6.

5. Install the screw shown in Figure 3-6.

Card removal

To remove the Model 7035 card, first unloosen the safety ground screw, unlock the card by pulling the latches outward, and pull the card out of the mainframe. Remember to handle the card by the edges and shields to avoid contamination that could degrade performance.

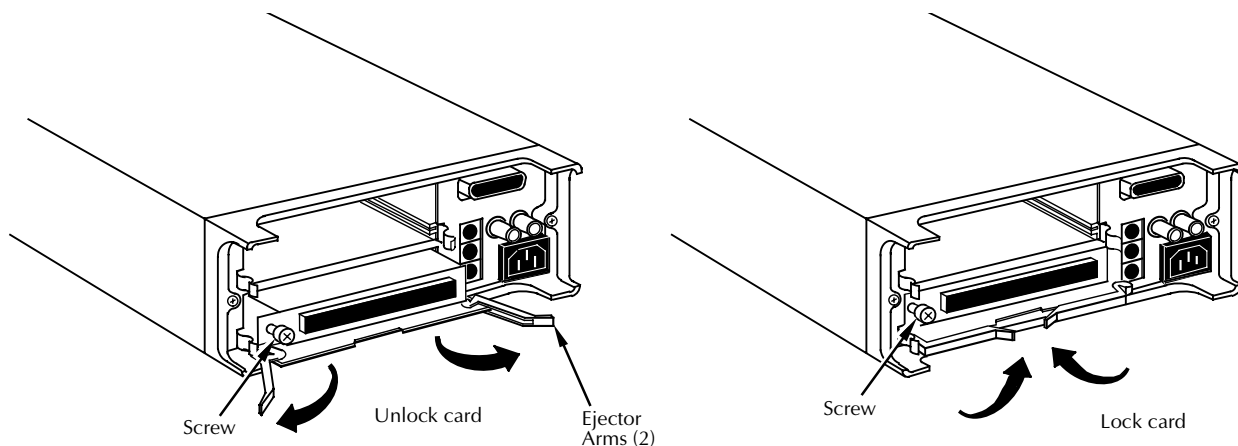

Figure 3-6
Model 7035 card installation in Model 7001

4

Operation

Introduction

The information in this section is formatted as follows:

- **Power limits** — Summarizes the maximum power limits of the Model 7035 card.
- **Mainframe control of card** — Summarizes the programming steps to control the card from the Model 7001/7002 mainframe.
- **Multiplexer switching examples** — Provides some typical applications for using the Model 7035.
- **Measurement considerations** — Reviews a number of considerations when using the Model 7035 to make measurements.

Power limits

CAUTION

To prevent damage to the card, do not exceed the maximum signal level specifications of the card.

Maximum signal levels

To prevent overheating or damage to the relays, never exceed the following maximum signal levels:

60V DC, 30V rms, 42V peak between any two inputs or chassis, 1A switched, 30VA (resistive load).

Mainframe control of card

The following information pertains to the Model 7035. It assumes that you are familiar with the operation of the Model 7001 or Model 7002 mainframe—whichever is used.

If you are not familiar with the operation of the mainframe in use, proceed to Getting Started (Section 3) of the Model 7001 or Model 7002 Instruction Manual after reading the following information.

7001 Display

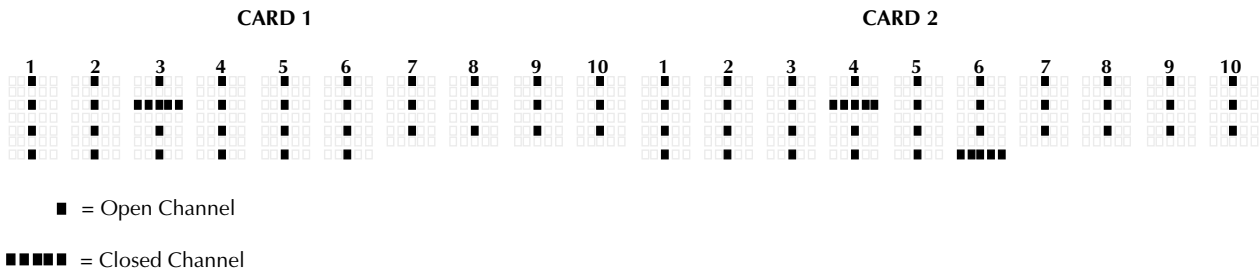

Figure 4-1
 Model 7001 channel status display

Channel assignments

The Model 7001 has a channel status display (Figure 4-1) that provides the real-time state of each available channel. The left portion of the display is for slot 1 (card 1), and the right portion is for slot 2 (card 2). For the Model 7002, channel status LED grids are used for the ten slots. The LED grid for slot 1 is shown in Figure 4-2.

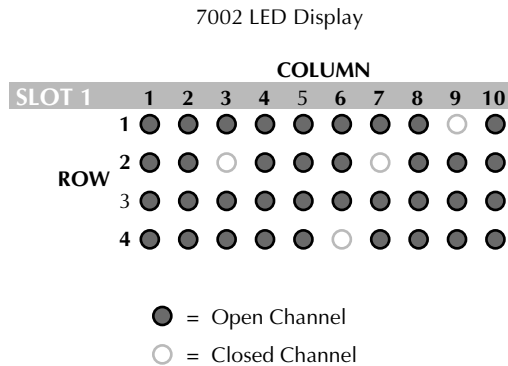

Figure 4-2
 Model 7002 channel status display (slot 1)

Organization of the channel status display for each slot is shown in Figure 4-3. The card contains 36 channels and is made up of nine multiplex banks (banks A through I) totaling 36 channels as shown in the illustration.

To control the card from the mainframe, each multiplexer input must have a unique channel assignment that includes the slot number that the card is installed in. The channel assignments for the card are provided in Figure 4-4. Each channel assignment is made up of the slot designator (1 or 2) and the channel (1 to 36). For the Model 7002, the slot designator can be from 1 to 10 since there are 10 slots. To be consistent with Model 7001/7002 operation, the slot designator and channel are separated by an exclamation point (!). Some examples of channel assignments are as follows:

- CHANNEL 1!1 = Slot 1, Channel 1 (Input 1 of Bank A)
- CHANNEL 1!36 = Slot 1, Channel 36 (Input 36 of Bank I)
- CHANNEL 2!23 = Slot 2, Channel 23 (Input 23 of Bank F)
- CHANNEL 2!36 = Slot 2, Channel 36 (Input 36 of Bank I)

These channels are displayed and controlled from the normal display state of the mainframe. If currently in the menu structure, return to the normal display state.

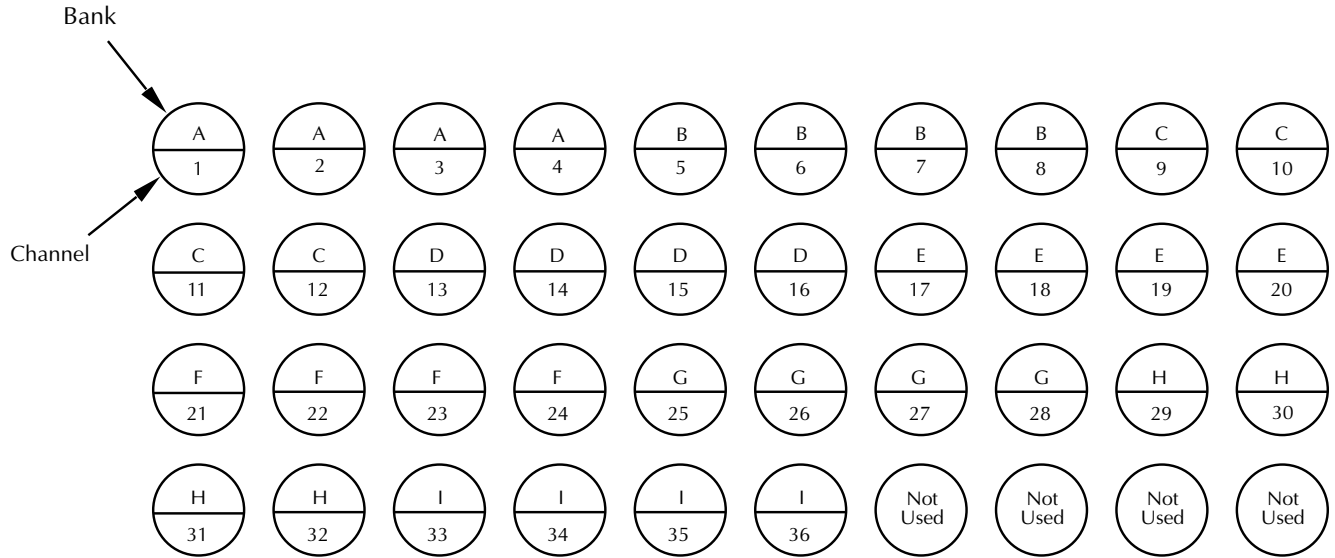
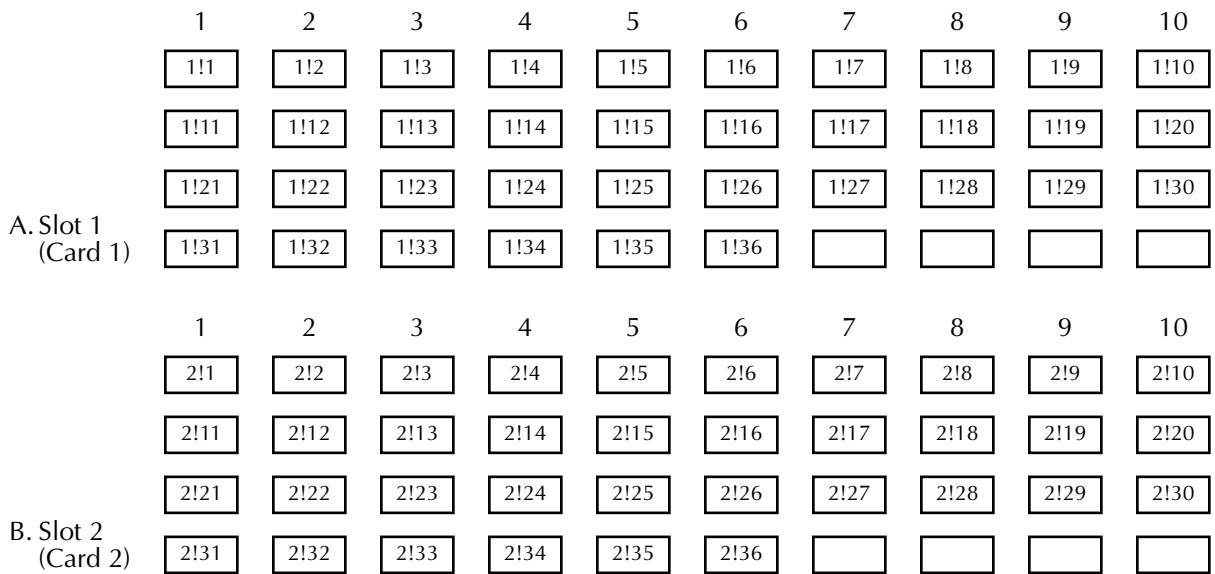

Figure 4-3
Display organization for multiplexer channels



Examples: 1!18 = Slot 1, Channel 18 (Input 18 of Bank E)
2!36 = Slot 2, Channel 36 (Input 36 of Bank I)

Figure 4-4
Channel assignments

Closing and opening channels

A channel is closed from the front panel by simply keying in the channel assignment and pressing CLOSE. For example, to close channel 6 (input 6 of bank B) of a multiplexer card installed in slot 2, key in the following channel list and press CLOSE:

```
SELECT CHANNELS 2!6
```

The above closed channel can be opened by pressing OPEN or OPEN ALL. The OPEN key opens only the channels specified in the channel list, and OPEN ALL turns off (opens) all channels.

NOTE

For the Model 7002 mainframe, you can use the light pen to turn output channels on and off.

The following display is an example of a channel list that consists of several channels:

```
SELECT CHANNELS 2!1, 2!3, 2!22-2!25
```

Notice that channel entries are separated by commas (.). A comma is inserted by pressing ENTER or the right cursor key (▶). The channel range is specified by using the hyphen (-) key to separate the range limits. Pressing CLOSE will close all the channels specified in the channel list. Pressing OPEN (or OPEN ALL) will open the channels.

Channel patterns can also be used in a channel list. This allows you to control unique relay patterns. Example:

```
SELECT CHANNELS 2!1, M1
```

Pressing CLOSE will close channel 2!1 and the channels that make up channel pattern M1. Refer to the mainframe instruction manual for information on defining channel patterns.

Scanning channels

Multiplexer channels are scanned by creating a scan list and configuring the Model 7001/7002 to perform a scan. The scan list is created in the same manner as a channel list (See the previous Closing and opening channels paragraph). However, the scan list is specified from the SCAN CHANNELS display mode. (The SCAN LIST key toggles between the channel list and the scan list.) The following shows an example of a scan list:

```
SCAN CHANNELS 2!1, 2!3, 2!21-2!25
```

When a scan is performed, the channels specified in the scan list will be scanned in the order that they are presented in the scan list.

Channel patterns can also be used in a scan list. This allows you to scan unique relay patterns. Example:

```
SCAN CHANNELS M1, M2, M3, M4
```

When M1 is scanned, the channels that make up channel pattern M1 will close. When M2 is scanned, the M1 channels will open and the channels that make up M2 will close. M3 and M4 are scanned in a similar manner. Refer to the instruction manual for the mainframe for information on defining channel patterns.

A manual scan can be performed by using the RESET default conditions of the Model 7001/7002. RESET is selected from the SAVESETUP menu of the main MENU. When RESET is performed, the mainframe is configured for an infinite number of manual scans. The first press of STEP takes the mainframe out of the idle state. The next press of STEP will close the first channel specified in the scan list. Each subsequent press of STEP will select the next channel in the scan list.

IEEE-488 bus operation

Bus operation is demonstrated using Microsoft QuickBASIC 4.5, the Keithley KPC-488.2 (or Capital Equipment Corporation) IEEE interface, and the HP-style Universal Language Driver (CECHP). Refer to "QuickBASIC 4.5 Programming" in the mainframe manual for details on installing the Universal Language Driver, opening driver files, and setting the input terminal. Program statements assume that the primary address of the mainframe is 07.

Closing and opening channels

The following SCPI commands are used to close and open multiplexer channels:

```
:CLOSe <list>      Closes specified channels.
:OPEN <list>|ALL    Opens specified (or all) channels.
```

The following program statement closes channels 1!1, 1!4 through 1!6 and the channels that make up channel pattern M1.

```
PRINT #1, "output 07; clos (@ 1!1, 1!4:1!6, M1)"
```

Notice that the colon (:) is used to separate the range limits.

Either of the following statements opens channels 1!1, 1!4 through 1!6 and the channels of M1:

```
PRINT #1, "output 07; open (@ 1!1, 1!4:1!6, M1)"
PRINT #1, "output 07; open all"
```

Scanning channels

There are many commands associated with scanning. However, it is possible to configure a scan using as little as four commands. These commands are listed as follows:

```
*RST
:TRIGger:COUNT:AUTO ON
:ROUTE:SCAN <list>
:INIT
```

The first command resets the mainframe to a default scan configuration. The second command automatically sets the channel count to the number of channels in the scan list, the third command defines the scan list, and the fourth command takes the Model 7001/7002 out of the idle state.

The following program fragment will perform a single scan of channels 1 through 4 of slot 1, and the channels that make up channel pattern M1:

```
PRINT #1, "output 07; *rst"
PRINT #1, "output 07; trig:coun:auto on"
PRINT #1, "output 07; scan (@ 1!1:1!4, M1)"
PRINT #1, "output 07; init"
```

The first statement selects the *RST default configuration for the scan. The second statement sets channel count to the scan-list-length (5). The third statement defines the scan list, and the last statement takes the mainframe out of the idle state. The scan is configured to start as soon as the :INIT command is executed.

When the above program fragment is run, the scan will be completed in approximately 216 milliseconds (3msec delay for channel closures and 3msec delay for each open), which is too fast to view from the front panel. An additional relay delay can be added to the program to slow down the scan for viewing. The program is modified by adding a statement to slow down the scan. Also, a statement is added to the beginning of the program to ensure that all channels are open before the scan is started. The two additional statements are indicated in bold typeface.

```
PRINT #1, "output 07; open all"
PRINT #1, "output 07; *rst"
PRINT #1, "output 07; trig:coun:auto on"
PRINT #1, "output 07; trig:del 0.5"
PRINT #1, "output 07; scan (@ 1!1:1!4, M1)"
PRINT #1, "output 07; init"
```

The first statement opens all channels, and the fourth statement sets a 1/2 second delay after each channel closes.

Multiplexer switching examples

This paragraph presents some typical applications for the Model 7035. These include two-wire and four-wire resistance tests.

The Model 7035 can be used to test a large number of resistors using only one test instrument or group of instruments. Such tests include two-wire and four-wire resistance measurements using a DMM as discussed in the following paragraphs.

Two-wire resistance tests

Figure 4-5 shows a typical test setup for making two-wire resistance measurements using one of the nine Model 7035 multiplex banks. The Model 7035 provides the switching function, while the resistance measurements are made by a Model 2000 DMM.

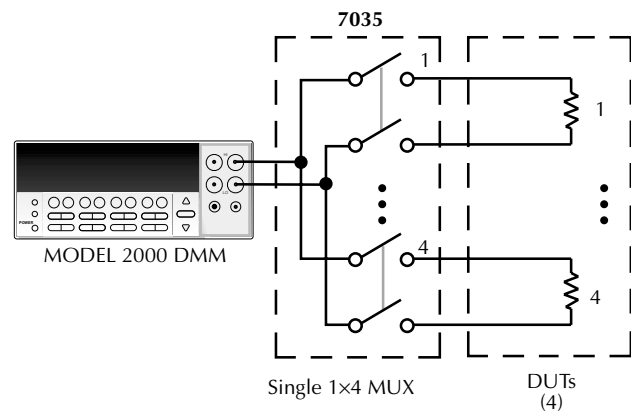

A. Test Configuration

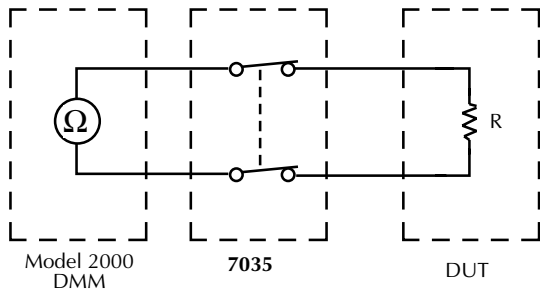

B. Simplified Equivalent Circuit

Figure 4-5
Two-wire resistance testing

Since only two-pole switching is required for two-wire resistance testing, one Model 7035 card can be used to switch up to 36 resistors by externally connecting the bank outputs using customer-supplied jumpers (Figure 4-6). Figure 4-6 is a simplified schematic, and each input contains two-pole switching.

Accuracy of measurements can be optimized by minimizing stray resistance.

Make connecting wires as short as possible to minimize path resistance. Another technique is to short one of the multiplexer inputs, close the shorted channel and then enable the DMM zero feature to cancel path resistance. Leave zero enabled for the entire test.

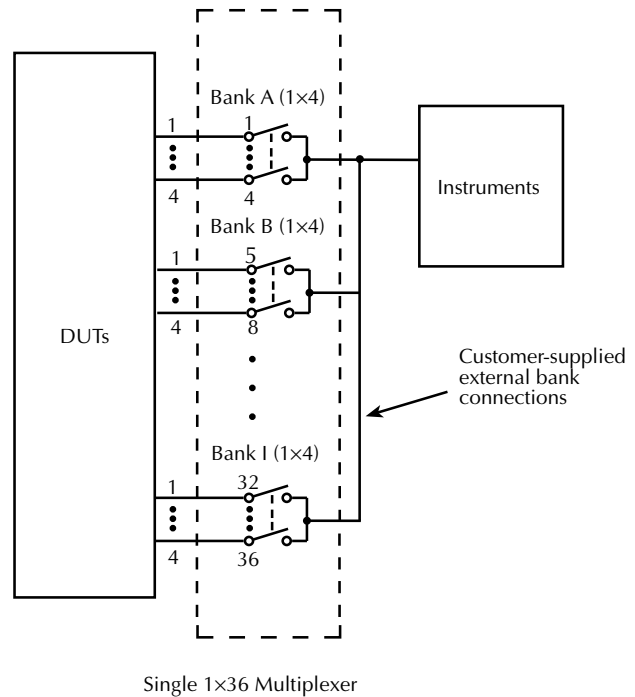

Figure 4-6
1x36 multiplex bank

Four-wire resistance tests

More precise measurements over a wider range of system and DUT conditions can be obtained by using the four-wire measurement scheme shown in Figure 4-7. Here, separate sense leads from the Model 2000 DMM are routed through the multiplexer to the resistor under test. The extra set of sense leads minimizes the effects of voltage drops across the test leads. Note, however, that an extra two poles of switching are required for each resistor tested. For this reason, only 16 resistors per card can be tested using this configuration because two channels must close at the same time.

The example shown in Figure 4-7 tests four devices using banks A and B. The appropriate channel pairs to close for the example are shown in Table 4-1.

Table 4-1

Paired channels in four-wire resistance example

Device under test (DUT)	Channel pair	Connection designations
1	1 and 5	Bank A, IN 1 and Bank B, IN 5
2	2 and 6	Bank A, IN 2 and Bank B, IN 6
3	3 and 7	Bank A, IN 3 and Bank B, IN 7
4	4 and 8	Bank A, IN 4 and Bank B, IN 8

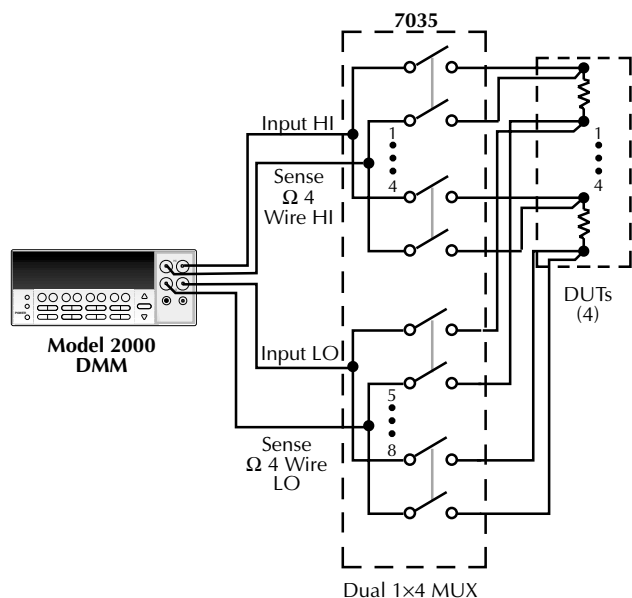

A. Test Configuration

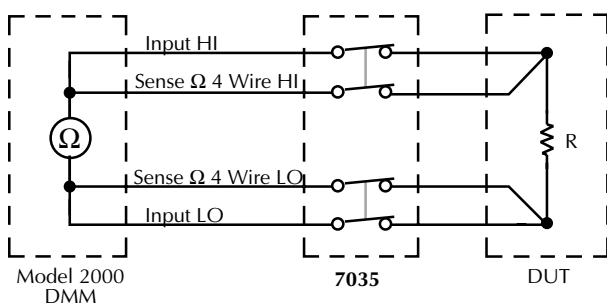

B. Simplified Equivalent Circuit

Figure 4-7
Four-wire resistance testing

Note that banks A and B must be electrically isolated. Likewise, if you were to configure a dual 1x8 four-wire resistance test by externally connecting the outputs of banks A and B and banks C and D using customer-supplied jumpers, you must electrically isolate banks A and B from banks C and D.

Although the four-wire connection scheme minimizes problems caused by voltage drops, there is one other potentially troublesome area associated with low resistance measurements: thermal EMFs caused by the relay contacts. In order to compensate for thermal EMFs, the offset-compensated ohms feature of the Model 2000 DMM should be used.

Measurement considerations

Many measurements made with the Model 7035 are subject to various effects that can seriously affect low-level measurement accuracy. The following paragraphs discuss these effects and ways to minimize them.

Path isolation

The path isolation is simply the equivalent impedance between any two test paths in a measurement system. Ideally, the path isolation should be infinite, but the actual resistance and distributed capacitance of cables and connectors results in less than infinite path isolation values for these devices.

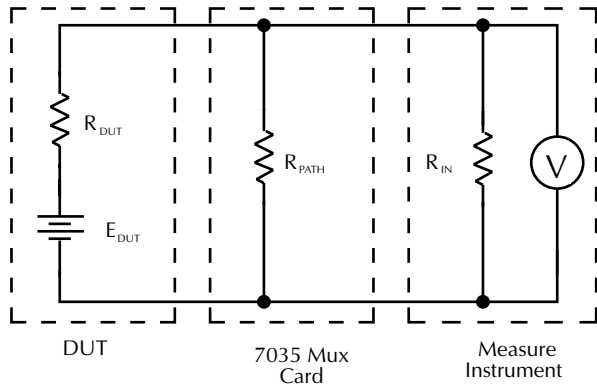

- R_{DUT} = Source Resistance of DUT
- E_{DUT} = Source EMF of DUT
- R_{PATH} = Path Isolation Resistance
- R_{IN} = Input Resistance of Measuring Instrument

Figure 4-8
Path isolation resistance

Path isolation resistance forms a signal path that is in parallel with the equivalent resistance of the DUT, as shown in Figure 4-8. For low-to-medium device resistance values, path isolation resistance is seldom a consideration; however, it can seriously degrade measurement accuracy when testing high-impedance devices. The voltage measured across such a device, for example, can be substantially attenuated by the voltage divider action of the device source resistance and path isolation resistance, as shown in Figure 4-9. Also, leakage currents can be generated through these resistances by voltage sources in the system.

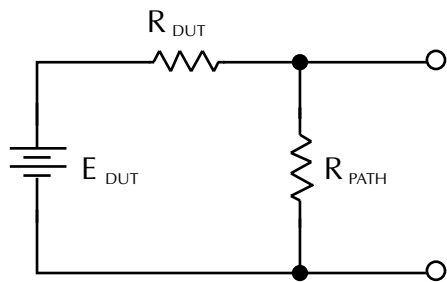

$$E_{OUT} = \frac{E_{DUT} R_{PATH}}{R_{DUT} + R_{PATH}}$$

Figure 4-9
Voltage attenuation by path isolation resistance

Any differential isolation capacitance affects DC measurement settling time as well as AC measurement accuracy. Thus, it is often important that such capacitance be kept as low as possible. Although the distributed capacitance of the multiplexer card is generally fixed by design, there is one area where you do have control over the capacitance in your system: the connecting cables. To minimize capacitance, keep all cables as short as possible.

Magnetic fields

When a conductor cuts through magnetic lines of force, a very small current is generated. This phenomenon will frequently cause unwanted signals to occur in the test leads of a switching multiplexer system. If the conductor has sufficient length, even weak magnetic fields like those of the earth can create sufficient signals to affect low-level measurements.

Two ways to reduce these effects are: (1) reduce the lengths of the test leads, and (2) minimize the exposed circuit area. In extreme cases, magnetic shielding may be required. Special metal with high permeability at low flux densities (such as mu metal) is effective at reducing these effects.

Even when the conductor is stationary, magnetically induced signals may still be a problem. Fields can be produced by various signals such as the AC power line voltage. Large inductors such as power transformers can generate substantial magnetic fields, so care must be taken to keep the switching and measuring circuits a good distance away from these potential noise sources.

At high current levels, even a single conductor can generate significant fields. These effects can be minimized by using twisted pairs, which will cancel out most of the resulting fields.

Radio frequency interference

Radio Frequency Interference (RFI) is a general term used to describe electromagnetic interference over a wide range of frequencies across the spectrum. Such RFI can be particularly troublesome at low signal levels, but it can also affect measurements at high levels if the problem is of sufficient severity.

RFI can be caused by steady-state sources such as radio or TV signals or some types of electronic equipment (microprocessors, high speed digital circuits, etc.), or it can result from impulse sources, as in the case of arcing in high-voltage environments. In either case, the effect on the measurement can be considerable if enough of the unwanted signal is present.

RFI can be minimized in several ways. The most obvious method is to keep the equipment and signal leads as far away from the RFI source as possible. Shielding the card, signal leads, sources, and measuring instruments will often reduce RFI to an acceptable level. In extreme cases, a specially constructed screen room may be required to sufficiently attenuate the troublesome signal.

Many instruments incorporate internal filtering that may help to reduce RFI effects in some situations. In some cases, additional external filtering may also be required. Keep in mind, however, that filtering may have detrimental effects on the desired signal.

Ground loops

When two or more instruments are connected together, care must be taken to avoid unwanted signals caused by ground loops. Ground loops usually occur when sensitive instrumentation is connected to other instrumentation with more than one signal return path such as power line ground. As shown in Figure 4-10, the resulting ground loop causes current to flow through the instrument LO signal leads and then back through power line ground. This circulating current develops a small but undesirable voltage between the LO terminals of the two instruments. This voltage will be added to the source voltage, affecting the accuracy of the measurement.

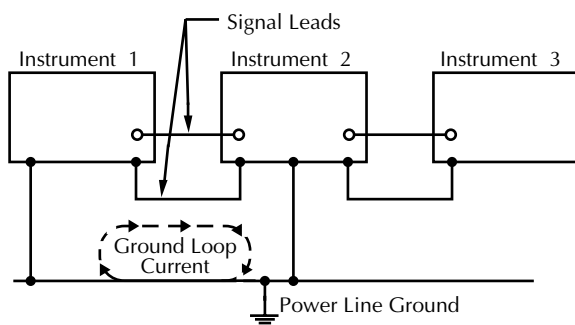

Figure 4-10
Power line ground loops

Figure 4-11 shows how to connect several instruments together to eliminate this type of ground loop problem. Here, only one instrument is connected to power line ground.

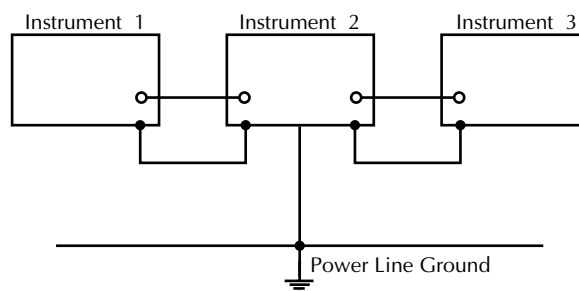

Figure 4-11
Eliminating ground loops

Ground loops are not normally a problem with instruments having isolated LO terminals. However, all instruments in the test setup may not be designed in this manner. When in doubt, consult the manual for each instrument in the test setup.

Keeping connectors clean

As is the case with any high-resistance device, the integrity of the connectors can be damaged if they are not handled properly. If connector insulation becomes contaminated, the insulation resistance will be substantially reduced, affecting high-impedance measurement paths.

Oils and salts from the skin can contaminate connector insulators, reducing their resistance. Also, contaminants present in the air can be deposited on the insulator surface. To avoid these problems, never touch the connector insulating material. In addition, the multiplexer card should be used only in clean, dry environments to avoid contamination.

If the connector insulators should become contaminated, either by inadvertent touching or from airborne deposits, they can be cleaned with a cotton swab dipped in clean methanol. After thoroughly cleaning, they should be allowed to dry for several hours in a low-humidity environment before use, or they can be dried more quickly using dry nitrogen.

AC frequency response

The AC frequency response of the Model 7035 is important in test systems that switch AC signals. Refer to the specifications at the front of this manual.

5

Service Information

WARNING

The information in this section is intended only for qualified service personnel. Some of the procedures may expose you to hazardous voltages that could result in personal injury or death. Do not attempt to perform these procedures unless you are qualified to do so.

Introduction

This section contains information necessary to service the Model 7035 multiplexer card and is arranged as follows:

- **Handling and cleaning precautions** — Discusses handling precautions and methods to clean the card should it become contaminated.
- **Performance verification** — Covers the procedures necessary to determine if the multiplexer card meets stated specifications.
- **Special handling of static-sensitive devices** — Reviews precautions necessary when handling static-sensitive devices.
- **Principles of operation** — Briefly discusses circuit operation.
- **Troubleshooting** — Presents some troubleshooting tips for the Model 7035 including relay replacement precautions.

Handling and cleaning precautions

Because of the high-impedance areas on the Model 7035, care should be taken when handling or servicing the card to prevent possible contamination. The following precautions should be taken when handling the card.

Handle the card only by the edges and shields. Do not touch any board surfaces, connectors, or components not associated with the repair. Do not touch areas adjacent to electrical contacts. When servicing the card, wear clean cotton gloves.

Do not store or operate the card in an environment where dust could settle on the circuit board. Use dry nitrogen gas to clean dust off the board if necessary.

Should it become necessary to use solder on the circuit board, use an OA-based (organic activated) flux. Remove the flux from the work areas when the repair has been completed. Use pure water along with clean cotton swabs or a clean soft brush to remove the flux. Take care not to spread the flux to other areas of the circuit board. Once the flux has been removed, swab only the repaired area with methanol, and then blowdry the board with dry nitrogen gas.

After cleaning, the card should be placed in a 50°C low humidity environment for several hours before use.

Performance verification

The following paragraphs discuss the performance verification procedures for the Model 7035, including path resistance, offset current, contact potential, and isolation.

CAUTION

Contamination will degrade the performance of the card. To avoid contamination, always grasp the card by the side edges or shields. Do not touch the connectors and do not touch the board surfaces or components. On plugs and receptacles, do not touch areas adjacent to the electrical contacts.

NOTE

Failure of any performance verification test may indicate that the card is contaminated. See the Handling and cleaning precautions paragraph to clean the card.

Environmental conditions

All verification measurements should be made at an ambient temperature between 18° and 28°C and at a relative humidity of less than 70%.

Recommended equipment

Table 5-1 summarizes the equipment necessary for performance verification along with an application for each unit.

Table 5-1
Verification equipment

Description	Model	Specifications	Applications
DMM	Keithley Model 2000	100Ω; 0.01%	Path resistance
Electrometer w/voltage source	Keithley Model 6517A	20pA, 200pA; 1% 100V source; 0.15%	Offset current, path isolation
Sensitive Digital Voltmeter	Keithley Model 182	3mV; 60ppm	Contact potential
Triax cable (unterminated)	Keithley Model 7025	—	Offset current
Low thermal cable (unterminated)	Keithley Model 1484	—	Contact potential

Multiplexer connections

The following information summarizes methods that can be used to connect test instrumentation to the card. Detailed connection information is provided in Section 3.

One method to make instrument connections to the multiplexer card is by hard-wiring a 96-pin female DIN connector then mating it to the connector on the Model 7035. Input and output shorting connections can also be done at the connector. The connector in the Model 7011-KIT-R connection kit (Table 3-2) can be used for this purpose. Pin identification for the connector is provided by Figure 3-1 and Table 3-1.

WARNING

When wiring a connector and device under test, do not leave any exposed wires or connections. No conductive part of the circuit may be exposed. Properly cover the conductive parts, or death by electric shock may occur.

CAUTION

After making solder connections to a connector, remove solder flux as explained in the Handling and cleaning precautions paragraph. Failure to clean the solder connections could result in degraded performance and prevent the card from passing verification tests.

Before pre-wiring any connectors or plugs, study the following test procedures to fully understand the connection requirements.

Channel resistance tests

Perform the following steps to verify that each contact of every relay is closing properly and that the resistance is within specification.

1. Turn off the Model 7001/7002 mainframe if it is on.
2. Turn on the Model 2000 and allow it to warm up for one hour before making measurements.
3. Connect all input terminals of bank A together to form one common terminal, as shown in Figure 5-1.
4. Set the Model 2000 to the 100 Ω range and connect the four test leads to the INPUT and INPUT Ω 4 WIRE jacks.
5. Short the four test leads together and zero the Model 2000. Leave zero enabled for the entire test.
6. Connect INPUT HI and INPUT Ω 4 WIRE HI of the Model 2000 to the common terminal (jumper on bank A inputs). It is recommended that the physical connections be made at inputs 1 and 4 of bank A, as shown in Figure 5-1.
7. Connect INPUT LO and INPUT Ω 4 WIRE LO to the HI (H) terminal of bank A.
8. Install the Model 7035 in slot 1 (CARD 1) of the Model 7001/7002.
9. Turn on the Model 7001/7002 and program it to close channel 1!1 (bank A, input 1). Verify that the resistance of this path is <1 Ω .
10. Open channel 1!1 and close channel 1!2 (bank A, input 2). Verify that the resistance of this path is <1 Ω .
11. Using the basic procedure in steps 9 and 10, check the resistance of bank A HI (H) terminal paths for inputs 3 and 4 (channels 1!3 and 1!4).
12. Turn off the Model 7001/7002 and move the INPUT LO and INPUT Ω 4 WIRE LO test leads to the LO (L) terminal of bank A.
13. Repeat steps 9 and 10 to check the LO (L) terminal paths of bank A (channels 1!1 through 1!4).
14. Repeat the basic procedure in steps 1 through 13 for bank B through I (channels 1!5 through 1!36).

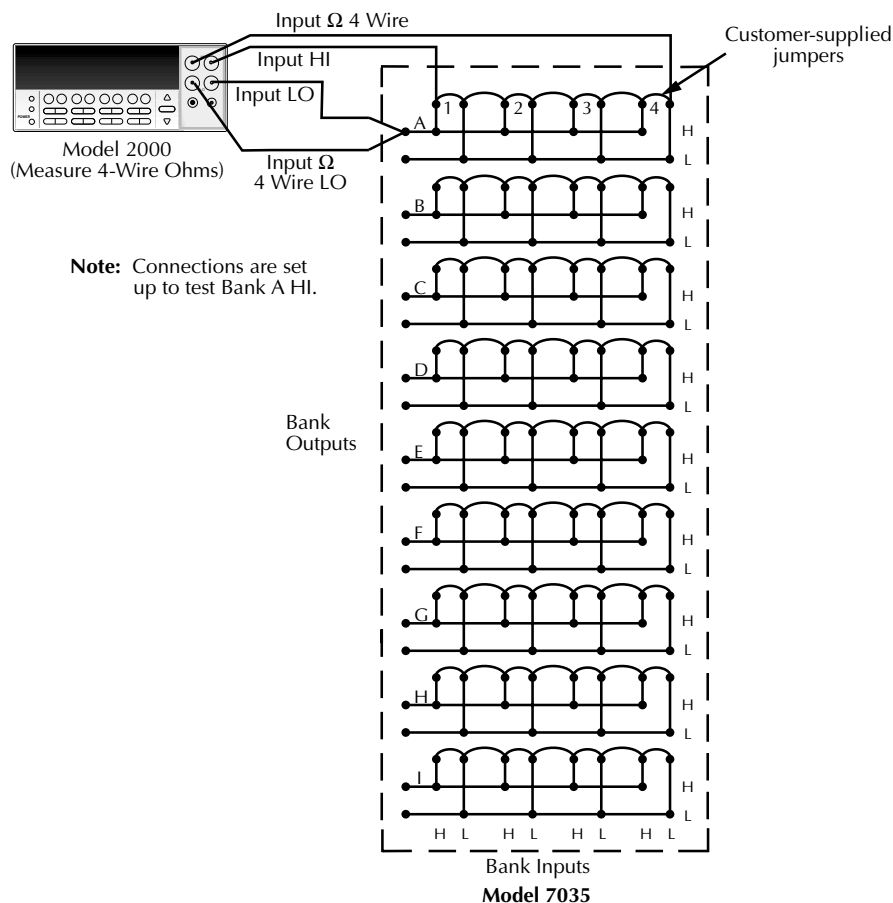

Figure 5-1
Path resistance test connections

Offset current tests

These tests check for leakage current between HI (H) and LO (L) (differential offset current) and from HI (H) and LO (L) to chassis (common-mode offset current) of each pathway. In general, these tests are performed by measuring the leakage current with an electrometer. In the following procedure, the Model 6517A is used to measure the leakage current. Test connections are shown in Figure 5-2.

Perform the following procedure to check offset current:

1. Turn off the Model 7001/7002 mainframe if it is on, and remove any jumpers or wires connected to the card.
2. Connect the triax cable to the Model 6517A, but do not connect it to the card at this time.
3. Turn on the Model 6517A and allow the unit to warm up for two hours before testing.
4. After warm up, select the 200pA range, and enable zero check and zero correct the instrument. Leave zero correct enabled for the entire procedure.
5. Connect the triax cable to bank A HI and LO, as shown in A.
6. Install the Model 7035 in slot 1 (CARD 1) of the mainframe.
7. Turn on the mainframe.
8. Program the unit to close channel 1!1 (bank A, input 1).
9. On the Model 6517A, disable zero check and allow the reading to settle. Verify that the reading is <100pA. This specification is the offset (leakage) current of the pathway.
10. Enable zero check on the Model 6517A and open channel 1!1 from the front panel of the mainframe.
11. Repeat the basic procedure in steps 8 through 10 to check the rest of the pathways (inputs 2 through 4) of bank A (channels 1!2 through 1!4).
12. Turn off the mainframe and change the electrometer connections to the next bank.
13. Repeat the basic procedure in steps 7 through 12 to check bank B through I, (channels 1!5 through 1!36).
14. Turn off the Model 7001/7002 and change the electrometer connections as shown in B. Note that electrometer HI is connected to HI and LO of the bank A output, which are jumpered together. Electrometer LO is connected to chassis.
15. Repeat steps 7 through 13 to check that the common mode offset current is <100pA.

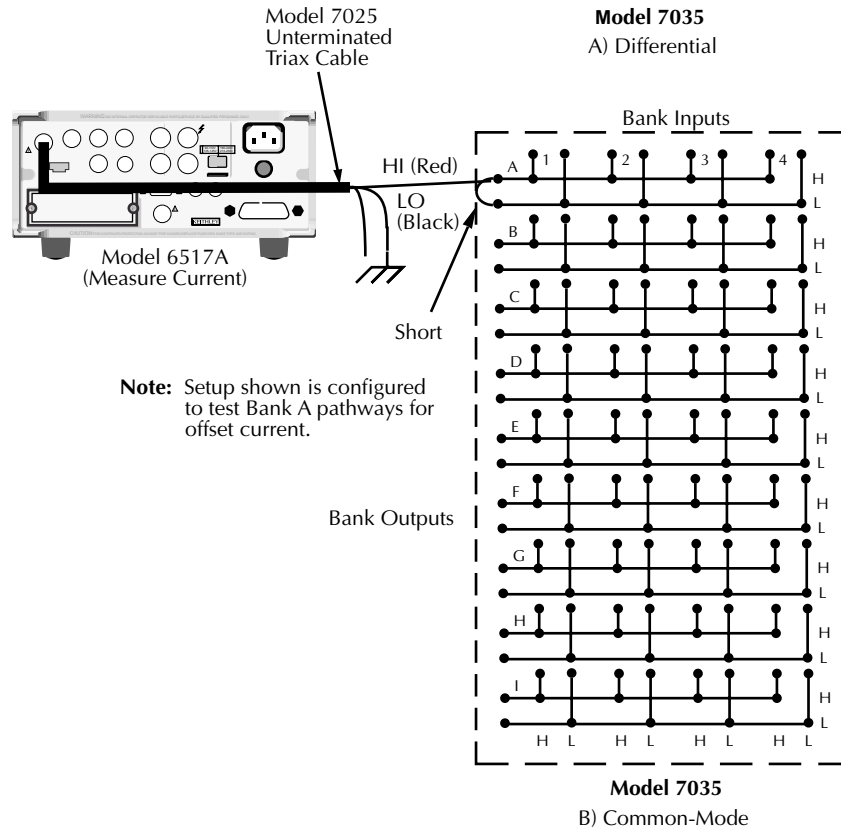
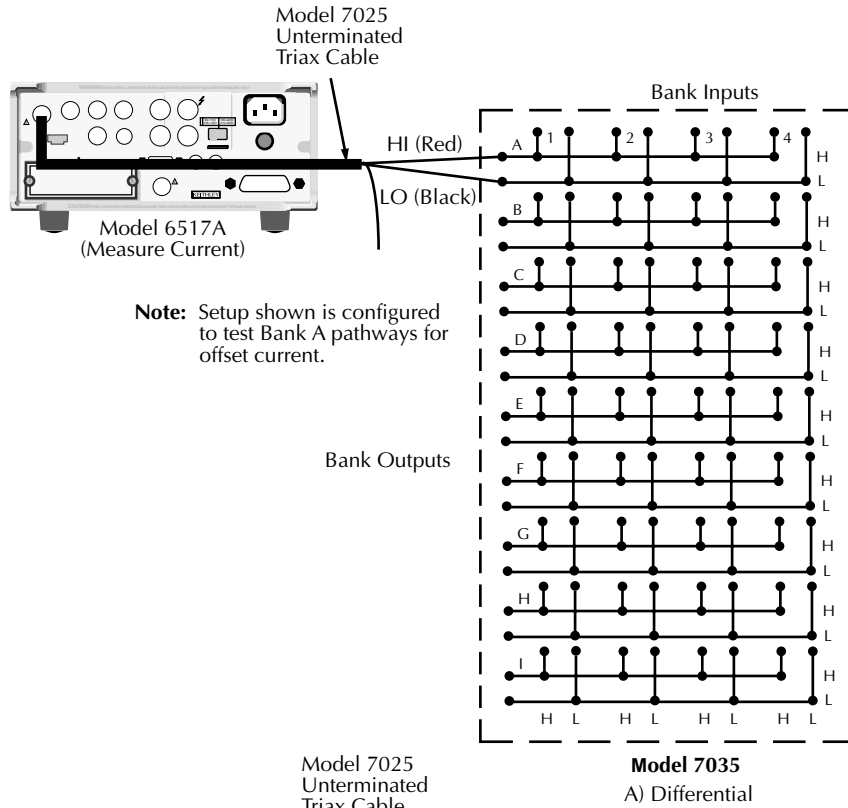

Figure 5-2
Differential offset current test connections

Contact potential tests

These tests check the EMF generated by each relay contact pair (H and L) for each pathway. The tests simply consist of using a sensitive digital voltmeter (Model 182) to measure the contact potential (Figure 5-3).

Perform the following procedure to check the contact potential of each path:

1. Turn off the Model 7001/7002 mainframe if it is on.
2. Place jumpers between banks A-B, B-C, C-D, D-E, E-F, F-G, G-H, and H-I.
3. Turn on the Model 182 and allow the unit to warm up to achieve rated accuracy.
4. Place a short between HI to LO on each input (channels 1-36).
5. Place a short between HI to LO on output bank I (long enough to cut with wire cutters).
6. Connect the Model 182 input leads to HI and LO output bank A using copper wires.
7. Install the Model 7035 in the Model 7001/7002 slot 1 and turn on the mainframe.
8. Allow Models 7001/7002, 7035, and 182 to warm up for two hours.
9. Select the 3mV range on the Model 182.
10. Press REL READING (on the Model 182) to null out internal offsets. Leave REL READING enabled for the entire procedure.
11. Turn off the mainframe. Remove the Model 7035 from slot 1. Cut the short on bank I output HI to LO.
12. Install the Model 7035 in mainframe slot 1, and turn on power.
13. Wait 15 minutes.
14. Program the mainframe to close channel 1!1.
15. After settling, verify that reading on the Model 182 is $<1\mu\text{V}$.
16. From the mainframe, open channel 1!1.
17. Repeat steps 14 through 16 for all 36 channels.

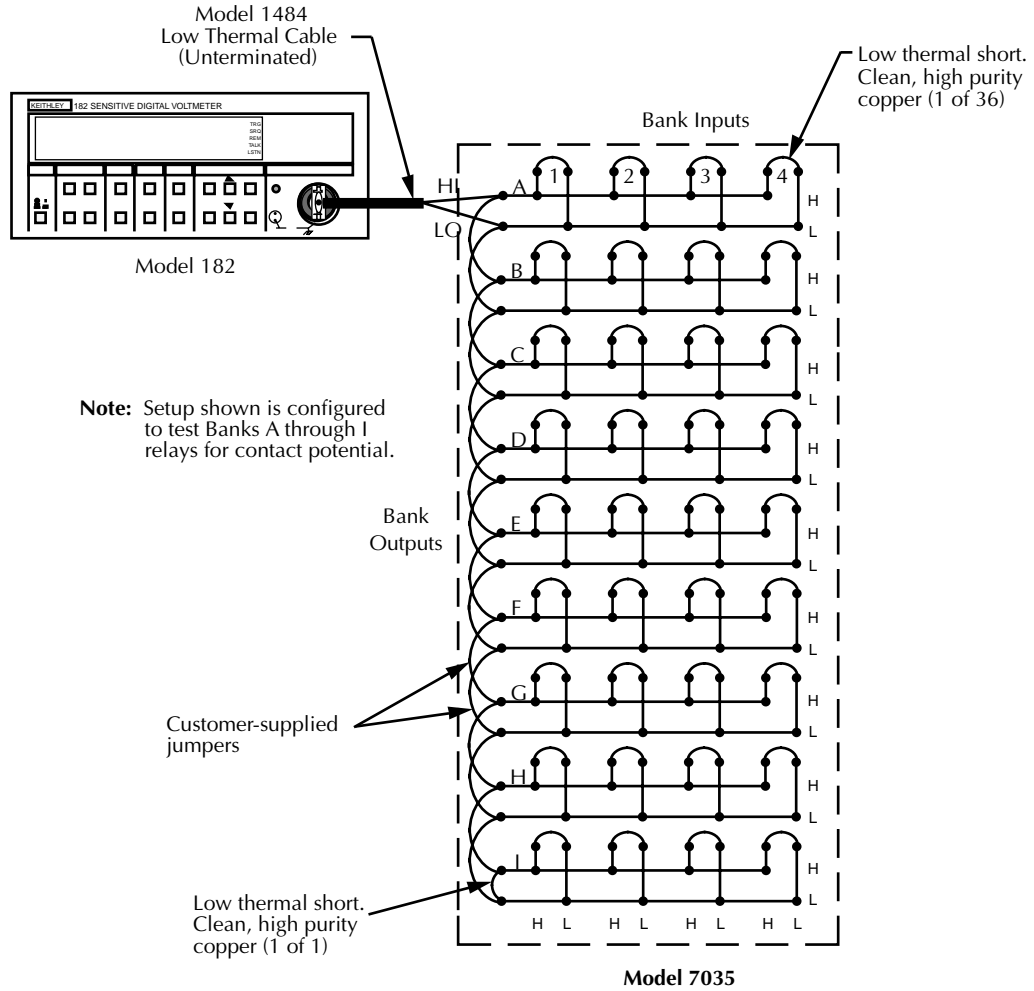

Figure 5-3
Contact potential test connections

Bank and channel-to-channel isolation tests

Bank isolation tests check the leakage resistance between adjacent banks. Channel-to-channel isolation tests check the leakage resistance between a bank output connection and a bank input connection with an adjacent bank input relay closed. In general, the tests are performed by applying a voltage (60V) across the leakage resistance and then measuring the current. The isolation resistance is then calculated as $R = V/I$. In the following procedure, the Model 6517A functions as both a voltage source and an ammeter. In the R function, the Model 6517A internally calculates the resistance from the known voltage and current levels and displays the resistive value.

Perform the following steps to check bank and channel-to-channel isolation:

1. Turn off the Model 7001/7002 mainframe if it is on, and remove any jumpers or test leads connected to the multiplexer.
2. Turn on the Model 6517A and allow the unit to warm up for two hours before testing.
3. Connect the electrometer to the Model 7035 as shown in Figure 5-4.
4. Install the Model 7035 in slot 1 (CARD 1) and turn on the mainframe.

WARNING

The following steps use a 60V source. Be sure to remove power from the circuit before making connection changes.

5. Place the Model 6517A in the R measurement function.

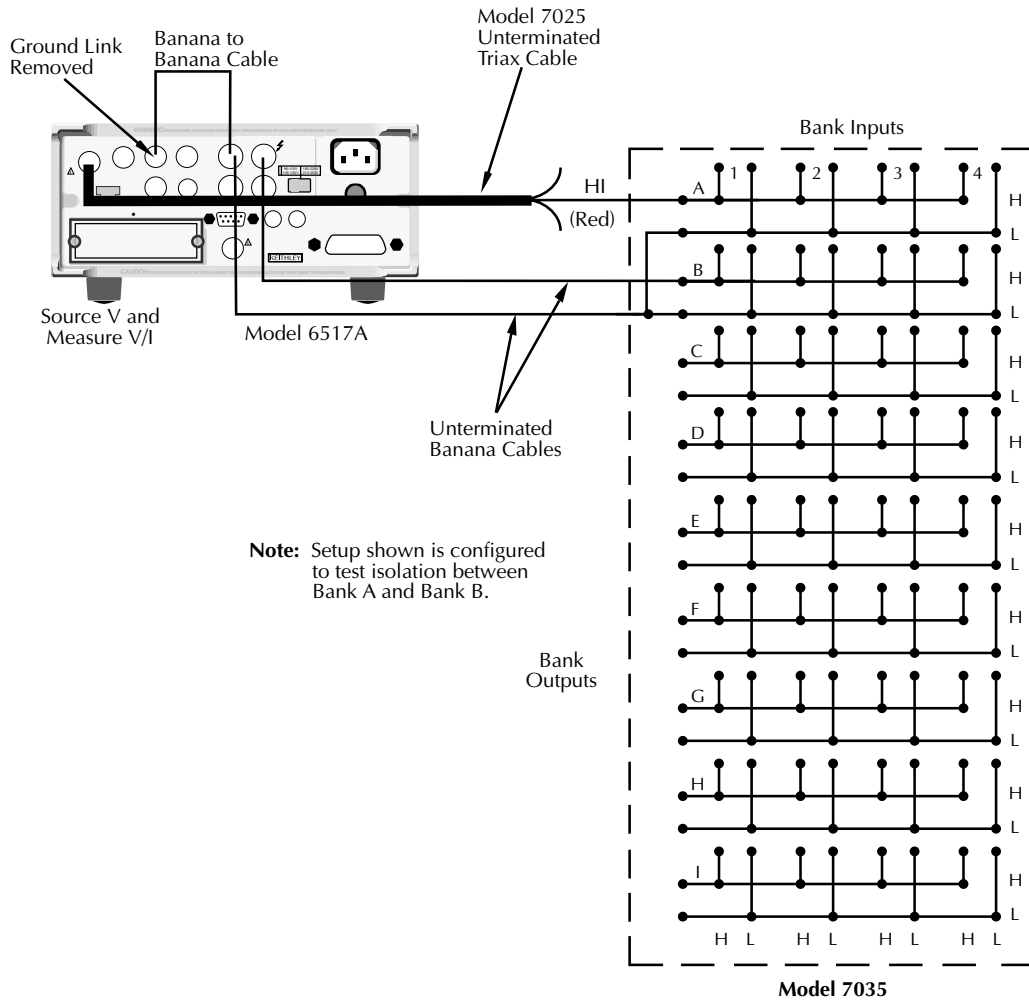

Figure 5-4
Bank isolation test connections

6. Turn on the Model 7001/7002 and program it to close channels 1!1 and 1!6 (bank A, input 1 and bank B, input 2).
7. On the Model 6517A, source +60V.
8. After allowing the reading on the Model 6517A to settle, verify that it is $>1\text{G}\Omega$ ($10^9\Omega$). This measurement is the leakage resistance (bank isolation) between bank A, input 1 and bank B, input 2.
9. Turn off the Model 6517A voltage source and the Model 7001/7002.
10. Move the electrometer connections to banks B and C.
11. Using Table 5-2 as a guide, repeat the basic procedure of steps 6 through 10 for the rest of the path pairs (test numbers 2 through 9 in the table).

Table 5-2*Bank isolation test summary*

Test number	Bank isolation	Test equipment location	Channels closed*
1	Bank A, Input 1 to Bank B, Input 2	Bank A and Bank B	1!1 and 1!6
2	Bank B, Input 2 to Bank C, Input 3	Bank B and Bank C	1!6 and 1!11
3	Bank C, Input 3 to Bank D, Input 4	Bank C and Bank D	1!11 and 1!16
4	Bank D, Input 1 to Bank E, Input 2	Bank D and Bank E	1!13 and 1!18
5	Bank E, Input 2 to Bank F, Input 3	Bank E and Bank F	1!18 and 1!23
6	Bank F, Input 3 to Bank G, Input 4	Bank F and Bank G	1!23 and 1!28
7	Bank G, Input 1 to Bank H, Input 2	Bank G and Bank H	1!25 and 1!30
8	Bank H, Input 2 to Bank I, Input 3	Bank H and Bank I	1!30 and 1!35
9	Bank H, Input 3 to Bank I, Input 4	Bank H and Bank I	1!31 and 1!36

*Assumes Model 7035 is installed in slot 1 of the mainframe. Program as slot (1) and channel.

- Turn off the Model 6517A voltage source and the Model 7001/7002.

NOTE

Refer to the following procedure to check channel-to-channel isolation.

- Connect the Model 6517A to the card as shown in Figure 5-5.
- Install the Model 7035 in slot 1 and turn on the mainframe.
- Program the mainframe to close channel 1!2 (bank A, input 2). Make sure all other channels are open.

- On the Model 6517A, source +60V.
- After allowing the reading on the Model 6517A to settle, verify that it is $>1G\Omega$ ($10^9\Omega$).
- Turn off the Model 6517A voltage source and the Model 7001/7002.
- Using Table 5-3 as a guide, perform tests 2 and 3 using steps 13 through 18 for the remaining bank A inputs. Remember to move bank input connections as indicated in the table.
- Use Table 5-3 (test numbers 4 through 29) and steps 6 through 19 to test banks B through I inputs. Move the electrometer connections shown in Figure 5-5 to the appropriate bank and move the bank input connections as indicated in the table.

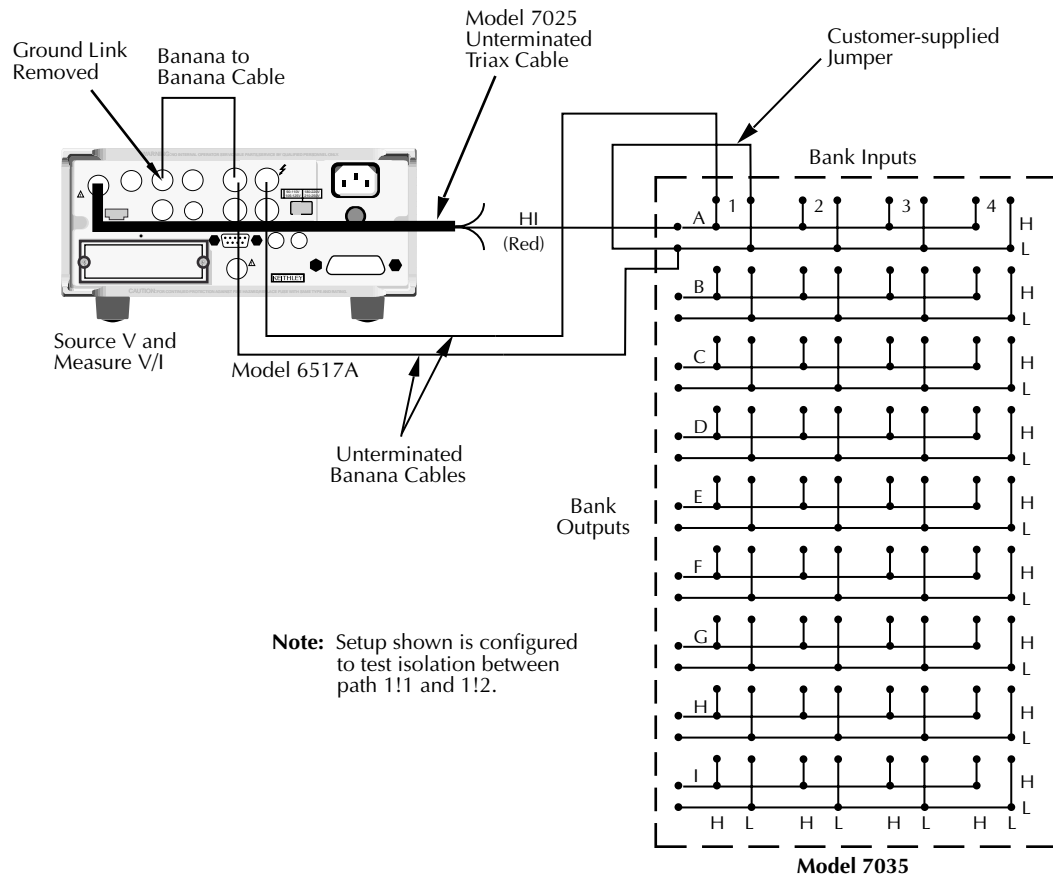

Figure 5-5
Channel-to-channel isolation test connections

Table 5-3
Channel-to-channel isolation test summary

Test number	Channel-to-channel isolation	Test equipment location	Channel closed*
1	Bank A, Input 1 to Bank A, Input 2	Bank A and Input 1	1!2
2	Bank A, Input 2 to Bank A, Input 3	Bank A and Input 2	1!3
3	Bank A, Input 3 to Bank A, Input 4	Bank A and Input 3	1!4
5	Bank B, Input 5 to Bank B, Input 6	Bank B and Input 5	1!6
6	Bank B, Input 6 to Bank B, Input 7	Bank B and Input 6	1!7
7	Bank B, Input 7 to Bank B, Input 8	Bank B and Input 7	1!8
9	Bank C, Input 9 to Bank C, Input 10	Bank C and Input 9	1!10
10	Bank C, Input 10 to Bank C, Input 11	Bank C and Input 10	1!11
11	Bank C, Input 11 to Bank C, Input 12	Bank C and Input 11	1!12
12	Bank D, Input 13 to Bank D, Input 14	Bank D and Input 13	1!14
13	Bank D, Input 14 to Bank D, Input 15	Bank D and Input 14	1!15
14	Bank D, Input 15 to Bank D, Input 16	Bank D and Input 15	1!16
15	Bank E, Input 17 to Bank E, Input 18	Bank E and Input 17	1!18
16	Bank E, Input 18 to Bank E, Input 19	Bank E and Input 18	1!19
17	Bank E, Input 19 to Bank E, Input 20	Bank E and Input 19	1!20
18	Bank F, Input 21 to Bank F, Input 22	Bank F and Input 21	1!22
19	Bank F, Input 22 to Bank F, Input 23	Bank F and Input 22	1!23
20	Bank F, Input 23 to Bank F, Input 24	Bank F and Input 23	1!24
21	Bank G, Input 25 to Bank G, Input 26	Bank G and Input 25	1!26
22	Bank G, Input 26 to Bank G, Input 27	Bank G and Input 26	1!27
23	Bank G, Input 27 to Bank G, Input 28	Bank G and Input 27	1!28
24	Bank H, Input 29 to Bank H, Input 30	Bank H and Input 29	1!30
25	Bank H, Input 30 to Bank H, Input 31	Bank H and Input 30	1!31
26	Bank H, Input 31 to Bank H, Input 32	Bank H and Input 31	1!32
27	Bank I, Input 33 to Bank I, Input 34	Bank I and Input 33	1!34
28	Bank I, Input 34 to Bank I, Input 35	Bank I and Input 34	1!35
29	Bank I, Input 35 to Bank I, Input 36	Bank I and Input 35	1!36

*Assumes Model 7035 is installed in slot 1 of the mainframe. Program as slot (1) and channel.

Differential and common-mode isolation tests

These tests check the leakage resistance (isolation) between HI (H) and LO (L) (differential) and from HI (H) and LO (L) to chassis (common-mode) of every bank and channel. In general, the test is performed by applying a voltage (60V) across the terminals and then measuring the leakage current. The isolation resistance is then calculated as $R = V/I$. In the following procedure, the Model 6517A functions as a voltage source and an ammeter. In the R function, the Model 6517A internally calculates the resistance from the known voltage and current levels and displays the resistance value.

Perform the following steps to check differential and common mode isolation:

1. Turn off the Model 7001/7002 mainframe if it is on, and remove any jumpers and test leads connected to the card.
2. Turn on the Model 6517A and allow the unit to warm up for two hours for rated accuracy.

WARNING

The following steps use a 60V source. Be sure to remove power from the circuit before making connection changes.

3. On the Model 6517A, set the voltage source for +60V. Make sure the voltage source is off.
4. Place the Model 6517A in the R measurement function.
5. With the Model 6517A off, connect the electrometer to bank A as shown in Figure 5-6.
6. Install the Model 7035 in slot 1 (CARD 1), and turn on the mainframe.
7. Make sure all the relays are open.
8. On the Model 6517A, source +60V.
9. After allowing the reading on the Model 6517A to settle, verify that it is $>1G\Omega$ ($10^9\Omega$). This measurement is the differential leakage resistance (isolation) of bank A.

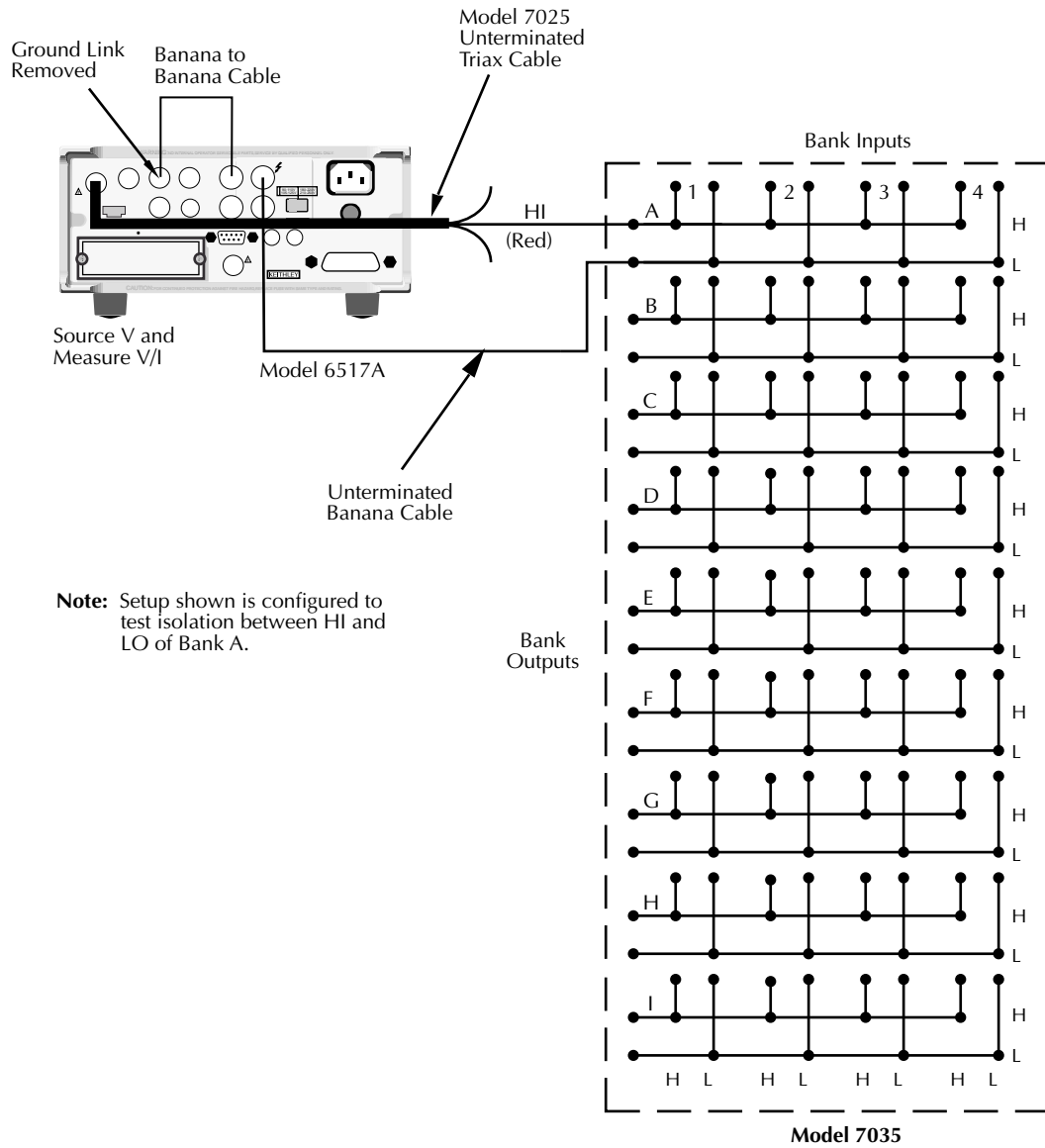

Figure 5-6
Differential isolation test connections

10. Turn off the Model 6517A voltage source.
11. Program the mainframe to close channel 1!1 (bank A, input 1).
12. On the Model 6517A, source +60V.
13. After allowing the reading on the Model 6517A to settle, verify that it is also $>1G\Omega$ ($10^9\Omega$). This measurement checks the differential isolation of input 1.
14. Using Table 5-4 as a guide, repeat the basic procedure in steps 10 through 13 to test inputs 2 through 4 of bank A (test numbers 3 through 5 of the table).
15. Using Table 5-4 (test numbers 6 through 45), repeat the basic procedure in steps 5 through 14 to test banks B through I.

16. Turn off the Model 6517A voltage source.

NOTE

Refer to the following procedure to check common-mode isolation.

17. Turn off the mainframe and connect the electrometer to the Model 7035 as shown in Figure 5-7.
18. Repeat steps 3 through 15 to check common mode isolation. Verify that each reading is $>1G\Omega$ ($10^9\Omega$).

Table 5-4
Differential and common-mode isolation testing

Test number	Differential or common mode isolation	Channel closed*	Test number	Differential or common mode isolation	Channel closed*
1	Bank A	None	26	Bank F	None
2	Bank A, Input 1	1!1	27	Bank F, Input 21	1!21
3	Bank A, Input 2	1!2	28	Bank F, Input 22	1!22
4	Bank A, Input 3	1!3	29	Bank F, Input 23	1!23
5	Bank A, Input 4	1!4	30	Bank F, Input 24	1!24
6	Bank B	None	31	Bank G	None
7	Bank B, Input 5	1!5	32	Bank G, Input 25	1!25
8	Bank B, Input 6	1!6	33	Bank G, Input 26	1!26
9	Bank B, Input 7	1!7	34	Bank G, Input 27	1!27
10	Bank B, Input 8	1!8	35	Bank G, Input 28	1!28
11	Bank C	None	36	Bank H	None
12	Bank C, Input 9	1!9	37	Bank H, Input 29	1!29
13	Bank C, Input 10	1!10	38	Bank H, Input 30	1!30
14	Bank C, Input 11	1!11	39	Bank H, Input 31	1!31
15	Bank C, Input 12	1!12	40	Bank H, Input 32	1!32
16	Bank D	None	41	Bank I	None
17	Bank D, Input 13	1!13	42	Bank I, Input 33	1!33
18	Bank D, Input 14	1!14	43	Bank I, Input 34	1!34
19	Bank D, Input 15	1!15	44	Bank I, Input 35	1!35
20	Bank D, Input 16	1!16	45	Bank I, Input 36	1!36
21	Bank E	None			
22	Bank E, Input 17	1!17			
23	Bank E, Input 18	1!18			
24	Bank E, Input 19	1!19			
25	Bank E, Input 20	1!20			

*Assumes Model 7035 is installed in slot 1 of the mainframe. Program as slot (1) and channel.

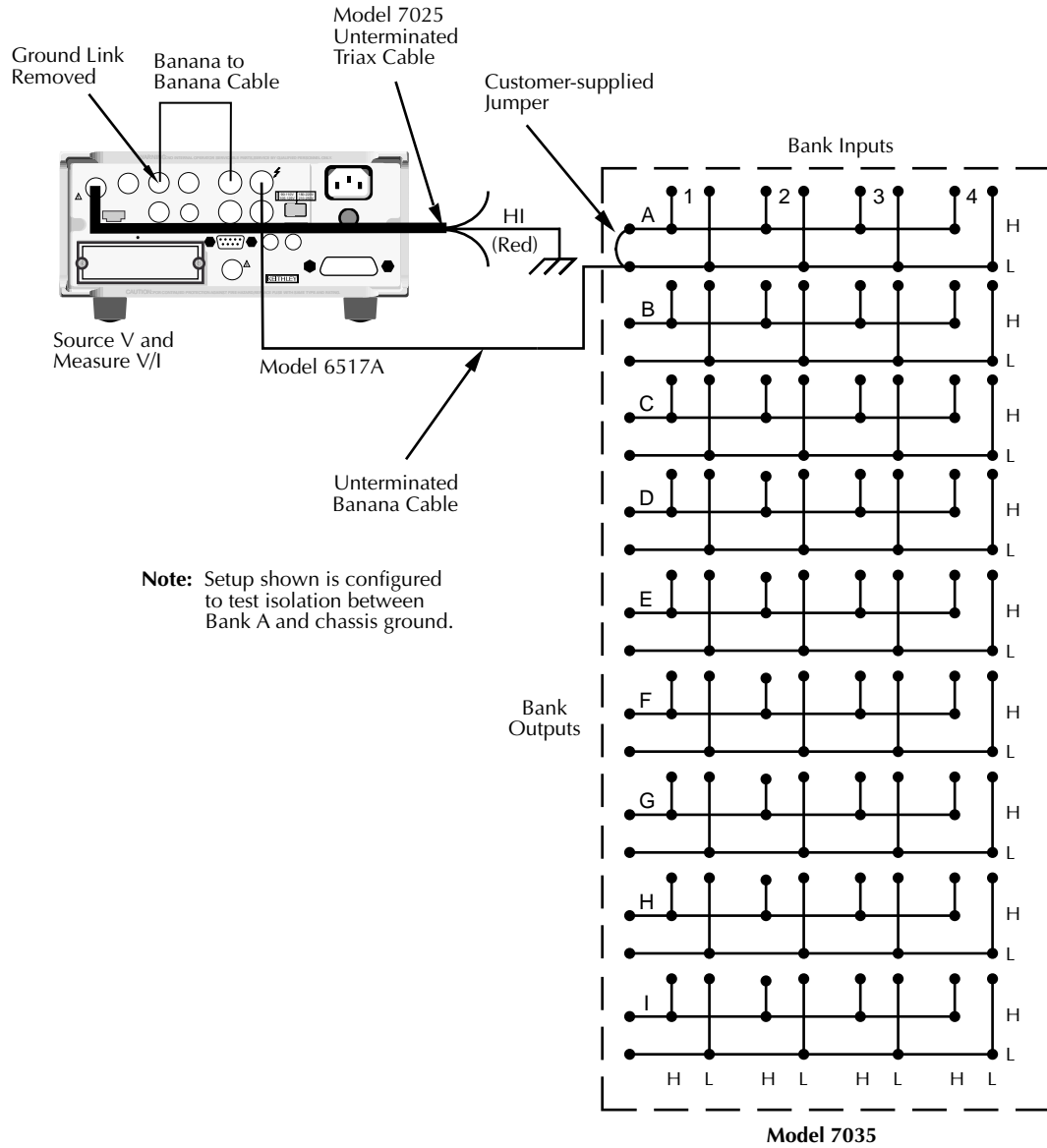

Figure 5-7
Common-mode isolation test connections

Special handling of static-sensitive devices

CMOS and other high-impedance devices are subject to possible static discharge damage because of the high-impedance levels involved. The following precautions pertain specifically to static-sensitive devices. However, since many devices in the Model 7035 are static-sensitive, it is recommended that they all be treated as static-sensitive.

1. Such devices should be transported and handled only in containers specially designed to prevent or dissipate static buildup. Typically, these devices will be received in anti-static containers made of plastic or foam. Keep these parts in their original containers until ready for installation.
2. Remove the devices from their protective containers only at a properly grounded work station. Also, ground yourself with a suitable wrist strap while working with these devices.
3. Handle the devices only by the body; do not touch the pins.

4. Any printed circuit board into which the device is to be inserted must first be grounded to the bench or table.
5. Use only anti-static type de-soldering tools and grounded-tip soldering irons.

Principles of operation

The paragraphs below discuss the basic operating principles for the Model 7035 and can be used as an aid in troubleshooting the card. The schematic drawings of the Model 7035 card are shown on drawing numbers 7035-106 and 7035-176 at the end of Section 6.

Block diagram

Figure 5-8 shows a simplified block diagram of the Model 7035. Key elements include the relay drivers and relays, as well as the ROM, which contains card ID and configuration information. These various elements are discussed in the following paragraphs.

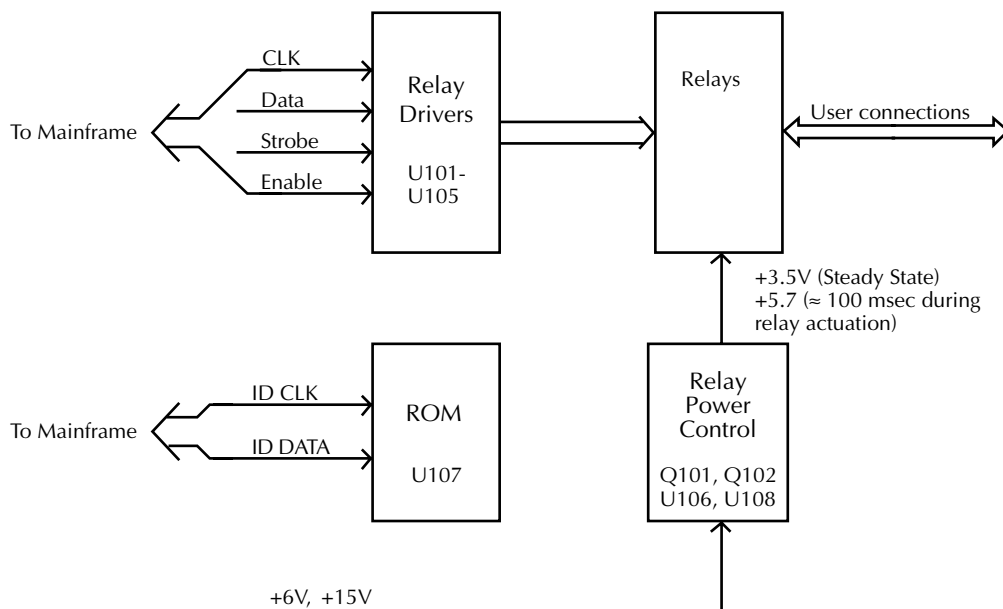

Figure 5-8
Model 7035 block diagram

ID data circuits

Upon power-up, card identification information from each card is read by the mainframe. This ID data includes such information as card ID, hardware settling time, and relay configuration information.

ID data is contained within an on-card EEPROM (U107). In order to read this information, the sequence described below is performed on power-up.

1. The IDDATA line (pin 5 of U107) is set from high to low while the IDCLK line (pin 6 of U107) is held high. This action initiates a start command to the ROM to transmit data serially to the mainframe (Figure 5-9).

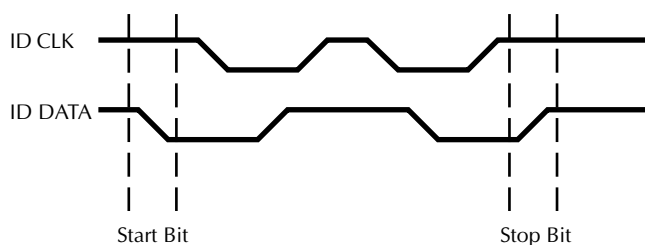

Figure 5-9
Start and stop sequences

2. The mainframe sends the ROM address location to be read over the IDDATA line. The ROM then transmits an acknowledge signal back to the mainframe, and it then transmits data at that location back to the mainframe (Figure 5-10).
3. The mainframe then transmits an acknowledge signal, indicating that it requires more data. The ROM will then sequentially transmit data after each acknowledge signal it receives.

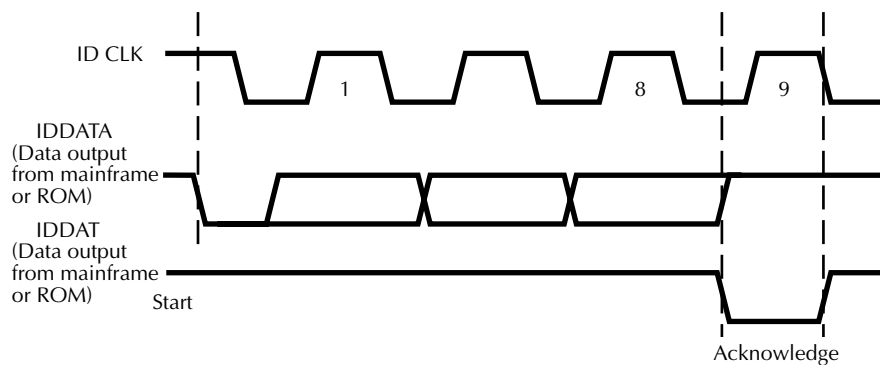

Figure 5-10
Transmit and acknowledge sequence

4. Once all data is received, the mainframe sends a stop command, which is a low-to-high transition of the IDDATA line with the IDCLK line held high (Figure 5-9).

Relay control

Card relays are controlled by serial data transmitted via the relay DATA line. A total of five bytes for each card are shifted in serial fashion into latches located in the card relay driver ICs. The serial data is clocked in by the CLK line. As data overflows one register, it is fed out the Q's line of the register down the chain.

Once all five bytes have shifted into the card, the STROBE line is set high to latch the relay information into the Q outputs of the relay drivers, and the appropriate relays are energized (assuming the driver outputs are enabled, as discussed below). Note that a relay driver output goes low to energize the corresponding relay.

Relay power control

A relay power control circuit, made up of Q101, Q102, U106, U108, and associated components, keeps power dissipated in relay coils at a minimum, thus reducing possible problems caused by thermal EMFs.

During steady-state operation, the relay supply voltage, +V, is regulated to +3.5V to minimize coil power dissipation. When a relay is first closed, the STROBE pulse applied to U106 changes the parameters of the relay supply voltage regulator, Q101, allowing the relay supply voltage, +V, to rise to +5.7V for about 100msec. This brief voltage rise ensures that relays close as quickly as possible. After the 100msec period has elapsed, the relay supply voltage (+V) drops back down to its nominal steady-state value of +3.5V.

Power-on safeguard

NOTE

The power-on safeguard circuit is actually located on the digital board in the Model 7001/7002 mainframe.

A power-on safeguard circuit, made up of U114 (a D-type flip-flop) and associated components, ensures that relays do not randomly energize on power-up and power-down. This circuit disables all relays (all relays are open) during power-up and power-down periods.

The PRESET line on the D-type flip-flop is controlled by the 68302 microprocessor, while the CLK line of the D-type flip-flop is controlled by a port line on the 68302 processor. The Q output of the flip-flop drives each card relay driver IC enable pin (U101-U105, pin 8).

When the 68302 microprocessor is in the reset mode, the flip-flop PRESET line is held low, and Q out immediately goes high, disabling all relays (relay driver IC enable pins are high, disabling the relays.) After the reset condition elapses (≈ 200 msec), PRESET goes high while Q out stays high. When the first valid STROBE pulse occurs, a low logic level is clocked into the D-type flip-flop, setting Q out low and enabling all relay drivers simultaneously. Note that Q out stays low, (enabling relay drivers) until the 68302 processor goes into a reset condition.

Troubleshooting

Troubleshooting equipment

Table 5-5 summarizes recommended equipment for troubleshooting the Model 7035.

Table 5-5

Recommended troubleshooting equipment

Description	Manufacturer and model	Application
Multimeter	Keithley 2000	Measure DC voltages
Oscilloscope	TEK 2243	View logic waveforms

Troubleshooting access

In order to gain access to the relay card top surface to measure voltages under actual operation conditions, perform the following steps:

1. Disconnect the connector card from the relay card.
2. Remove the Model 7001/7002 cover.
3. Install the relay card in the CARD 1 slot location.
4. Turn on Model 7001/7002 power to measure voltages (see the following Troubleshooting procedure paragraph).

Troubleshooting procedure

Table 5-6 summarizes card troubleshooting.

WARNING

Lethal voltages are present within the Model 7001/7002 mainframe. Some of the procedures may expose you to hazardous voltages. Observe standard safety precautions for dealing with live circuits. Failure to do so could result in personal injury or death.

CAUTION

Observe the following precautions when troubleshooting or repairing the card:

To avoid contamination, which could degrade card performance, always handle the card only by the handle and side edges. Do not touch edge connectors, board surfaces, or components on the card. Also, do not touch areas adjacent to electrical contacts on connectors.

Use care when removing relays from the PC board to avoid pulling traces away from the circuit board. Before attempting to remove a relay, use an appropriate de-soldering tool such as a solder sucker to clear each mounting hole completely free of solder. Each relay pin must be free to move in its mounting hole before removal. Also, make certain that no burrs are present on the ends of the relay pins.

Table 5-6
Troubleshooting procedure

Step	Item/component	Required condition	Comments
1	GND test point (C114)		All voltages referenced to digital ground (GND pad).
2	+6V pad (Q101, pin 2)	+6VDC	Relay voltage.
3	+5V pad (C103)	+5VDC	Logic voltage.
4	+15V pad (R101)	+15VDC	Relay bias voltage.
5	+V pad (C114)	+3.5VDC*	Regulated relay voltage.
6	U107, pin 6	ID CLK pulses	During power-up only.
7	U107, pin 5	ID DATA pulses	During power-up only.
8	U101, pin 7	STROBE pulse	End of relay update sequence.
9	U101, pin 2	CLK pulses	During relay update sequence only.
10	U101, pin 3	DATA pulses	During relay update sequence only.
11	U101-U105, pins 10-18	Low with relay energized; high with relay de-energized.	Relay driver outputs.

*+3.5VDC present at +V pad under steady-state conditions. This voltage rises to +5.7VDC for about 100msec when relay configuration is changed.

6

Replaceable Parts

Introduction

This section contains replacement parts information, schematic diagrams, and component layout drawings for the Model 7035.

Parts lists

Parts lists for the various circuit boards are included in tables integrated with schematic diagrams and component layout drawings for the boards. Parts are listed alphabetically in order of circuit designation.

Ordering information

To place an order, or to obtain information concerning replacement parts, contact your Keithley representative or the factory (see inside front cover for addresses). When ordering parts, be sure to include the following information:

1. Card model number 7035
2. Card serial number
3. Part description
4. Circuit description, if applicable
5. Keithley part number

Factory service

If the card is to be returned to Keithley Instruments for repair, perform the following:

1. Complete the service form at the back of this manual and include it with the card.
2. Carefully pack the card in the original packing carton or the equivalent.
3. Write ATTENTION REPAIR DEPT on the shipping label.

NOTE

It is not necessary to return the mainframe with the card.

Component layouts and schematic diagrams

Component layout drawings and schematic diagrams are included on the following pages integrated with the parts lists:

Table 6-1 — Parts List, Relay Card for Model 7035.

7035-100 — Component Layout, Relay Card for Model C7035.

7035-106 — Schematic, Relay Card for Model 7035.

Table 6-2 — Parts List, Mass-Terminated Connector Card for Model 7035.

7035-170 — Component Layout, Mass-Terminated Connector Card for Model 7035.

7035-176 — Schematic, Mass-Terminated Connector Card for Model 7035.

Table 6-3 — Parts List, Model 7011-KIT-R 96-pin Female DIN Connector Kit.

Table 6-1
Relay card for Model 7035 parts list

Circuit designation	Description	Keithley part no.
	2-56×3/16 PHILLIPS PAN HEAD SCREW (RELAY BOARD TO SHIELD)	2-56×3/16PPH
	2-56×5/8 PHILLIPS PAN HEAD FASTENER	FA-245-1
	2-56×5/16 PHILLIPS PAN HEAD SEMS SCREW (CONNECTOR TO SHIELD)	2-56×5/16PPHSEM
	4-40×3/16 PHILLIPS PAN HEAD SEMS SCREW	4-40×3/16PPHSEM
	4-40 PEM NUT	FA-131
	EJECTOR ARM	7011-301B
	IC, SERIAL EPROM, 24C01P	IC-737
	ROLL PIN (FOR EJECTOR ARMS)	DP-6-1
	SHIELD	7011-305C
	STANDOFF, 2 CLEARANCE	ST-204-1
C101-107, 112, 114,116,123,125	CAP, 0.1mF, 20% 50V, CERAMIC	C-365-.1
C108,113,115	CAP, 150pF, 10%, 1000V, CERAMIC	C-64-150P
C109,111	CAP, 1mF, 20% 50V, CERAMIC	C-237-1
C110	CAP, 0.001mF, 20%, 500V, CERAMIC	C-22-.001
C122,124	CAP, 10mF, -20+100% 25V, ALUM ELEC	C-314-10
J1002,1003	CONN, 48-PIN, 3-ROW	CS-736-2
K101-136	RELAY, ULTRA-SMALL POLARIZED, TF2E-5V	RL-149
P2001	CONN, 32-PIN, 2-ROW	CS-775-1
Q101	TRANS, NPN PWR, TIP31 (T0-220AB)	TG-253
Q102	TRANS, N CHAN MOSPOW FET, 2N7000 (T0-92)	TG-195
R101,102	RES, 560, 10%, 1/2W, COMPOSITION	R-1-560
R103	RES, 1K, 1%, 1/8W, METAL FILM	R-88-1K
R104	RES, 2.49K, 1%, 1/8W, METAL FILM	R-88-2.49K
R105	RES, 1.15K, 1%, 1/8W, METAL FILM	R-88-1.15K
R106	RES, 10K, 5%, 1/4W, COMPOSITION OR FILM	R-76-10K
R107	RES, 220K, 5%, 1/4W, COMPOSITION OR FILM	R-76-220K
S107	SOCKET	S0-72
ST101	4-40×0.812 STANDOFF	ST-137-20
U101-105	IC, 8-BIT SERIAL-IN LATCH DRIVER, 5841A	IC-536
U106	IC, RETRIG MONO MULTIVIB, 74HC123	IC-492
U107	PROGRAM	7035-800A01
U108	IC, AJD SHUNT REGULATOR, TL431CLP	IC-677

Table 6-2
Mass-terminated connector card for Model 7035 parts list

Circuit designation	Description	Keithley part no.
	2-56×3/16 PHILLIPS PAN HEAD SCREW (FOR SHIELD) 2-56×3/8 PHILLIPS PAN HEAD SCREW (FOR BRACKET) 2-56×7/16 PHILLIPS PAN HEAD SCREW (FOR SHIELD AND SHIMS) 4-40×1/4 PHILLIPS PAN HEAD SEMS SCREW (RELAY BOARD TO CONNECTOR BOARD) BRACKET CONNECTOR SHIM SHIELD STANDOFF	2-56×3/16PPH 2-56×3/8PPH 2-56×7/16PPH 4-40×1/4PPHSEM 7011-307 7011-309A 7011-311A ST-203-1
J1004	CONN, 96-PIN, 3-ROW	CS-514
P1002,1003	CONN, 48-PIN, 3-ROW	CS-748-3

Table 6-3
Model 7011-KIT-R 96-pin female DIN connector kit parts list

Description	Keithley part no.
96-PIN FEMALE DIN CONNECTOR	CS-787-1
BUSHING, STRAIN RELIEF	BU-27
CABLE ADAPTER, REAR EXIT (INCLUDES TWO CABLE CLAMPS)	CC-64
CONNECTOR HOUSING	CS-788

LTR.	ECA NO.	REVISION	ENG.	DATE
B	19789	RELEASED	SZ	3/24/97
C	20065	REFER TO ECA	ELS	4/9/99
C1	25918	CHANGED U107 TO TC17-100	ELS	6/02/01

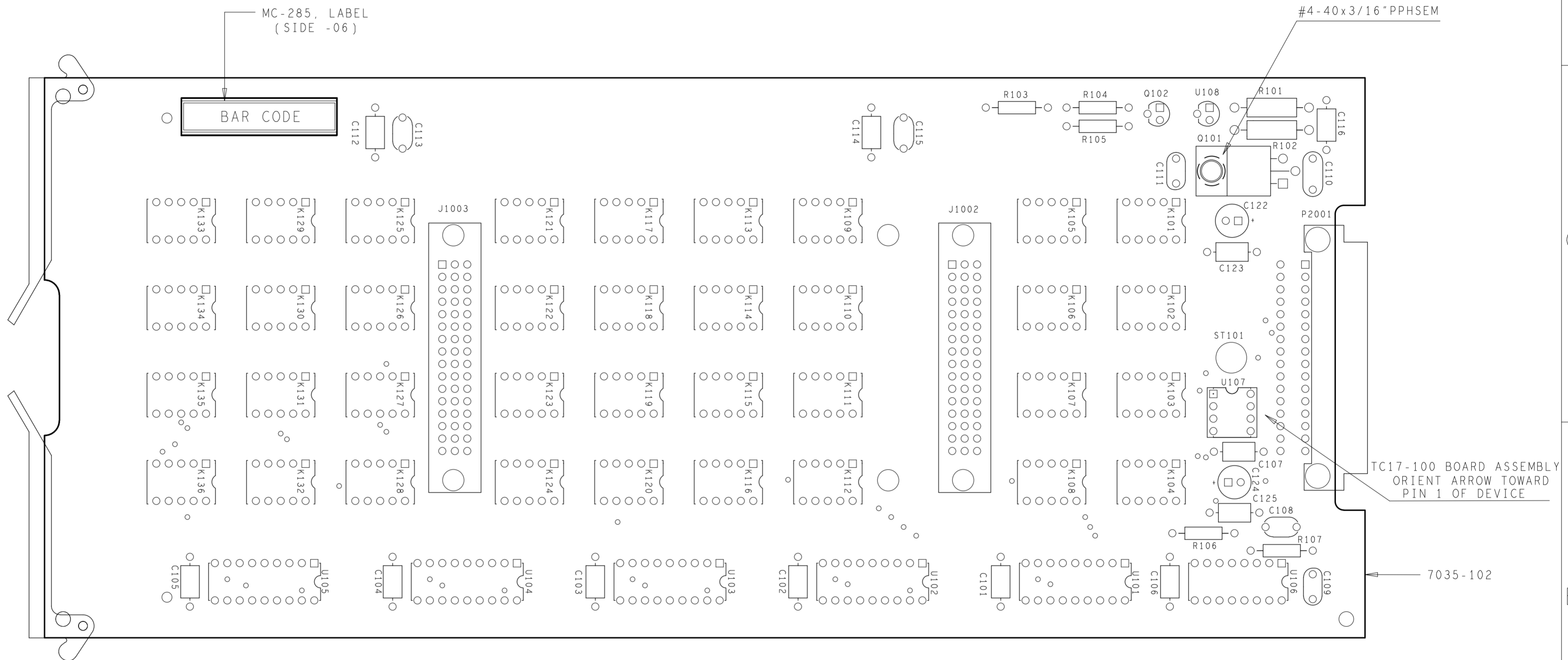

NOTE: FOR COMPONENT INFORMATION, REFER TO PRODUCT STRUCTURE.

7035	C7021-101	1
MODEL	NEXT ASSEMBLY	QTY.
USED ON		

KEITHLEY KEITHLEY INSTRUMENTS INC. CLEVELAND, OHIO 44139	DIM ARE IN IN. UNLESS OTHERWISE NOTED	DATE 4/9/99	SCALE 3:2	TITLE COMPONENT LAYOUT, RELAY BOARD
	DIM. TOL. UNLESS OTHERWISE SPECIFIED	DRN MRS	APPR. PS	
XX=+.01 ANG.=+1 XXX=+.005 FRAC.=+1/64	DO NOT SCALE THIS DRAWING		C NO.	7035-100

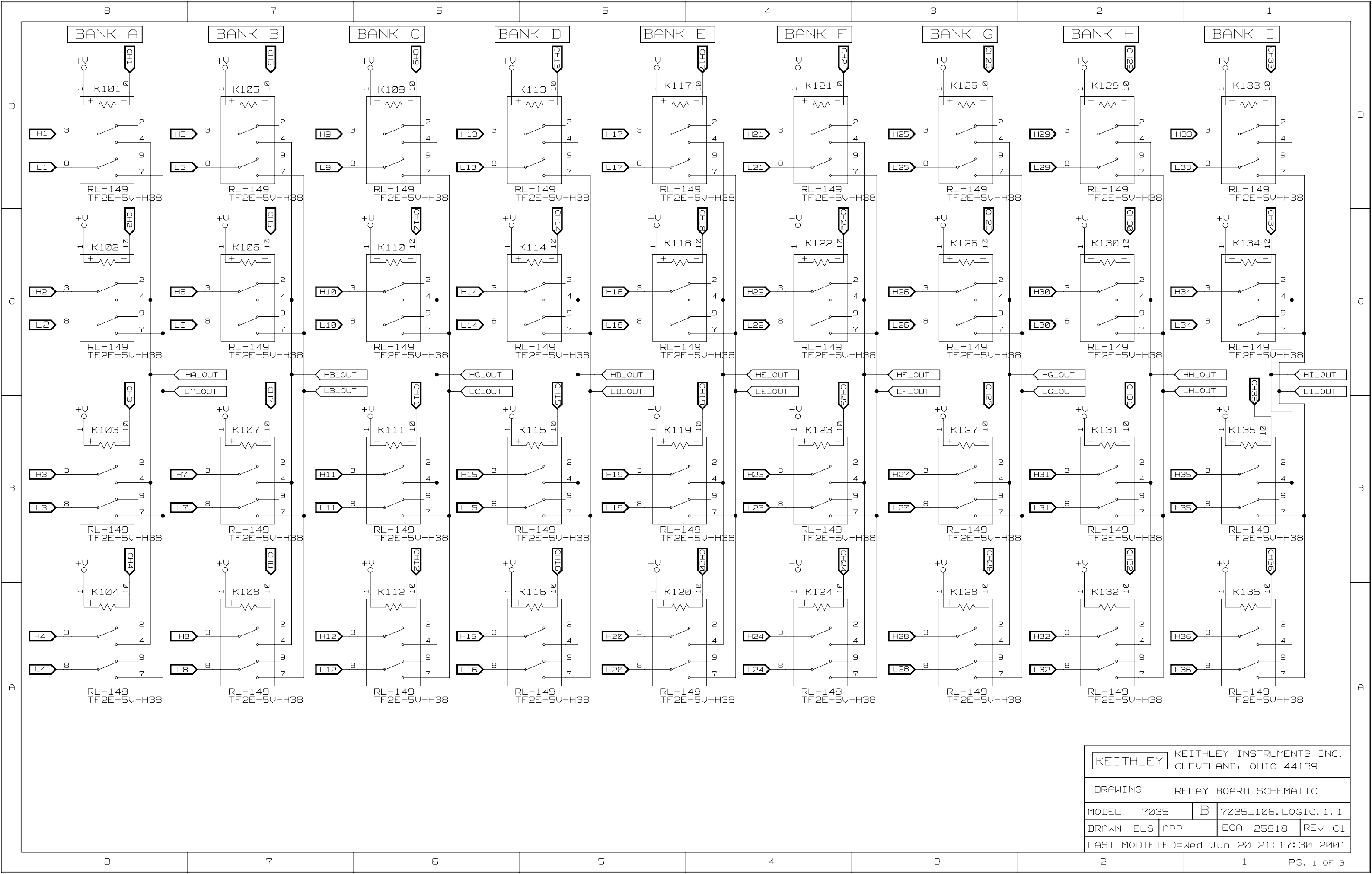

KEITHLEY				KEITHLEY INSTRUMENTS INC. CLEVELAND, OHIO 44139			
DRAWING				RELAY BOARD SCHEMATIC			
MODEL 7035		B		7035_106.LOGIC.1.1			
DRAWN ELS		APP		ECA 25918		REV C1	
LAST_MODIFIED=Wed Jun 20 21:17:30 2001							

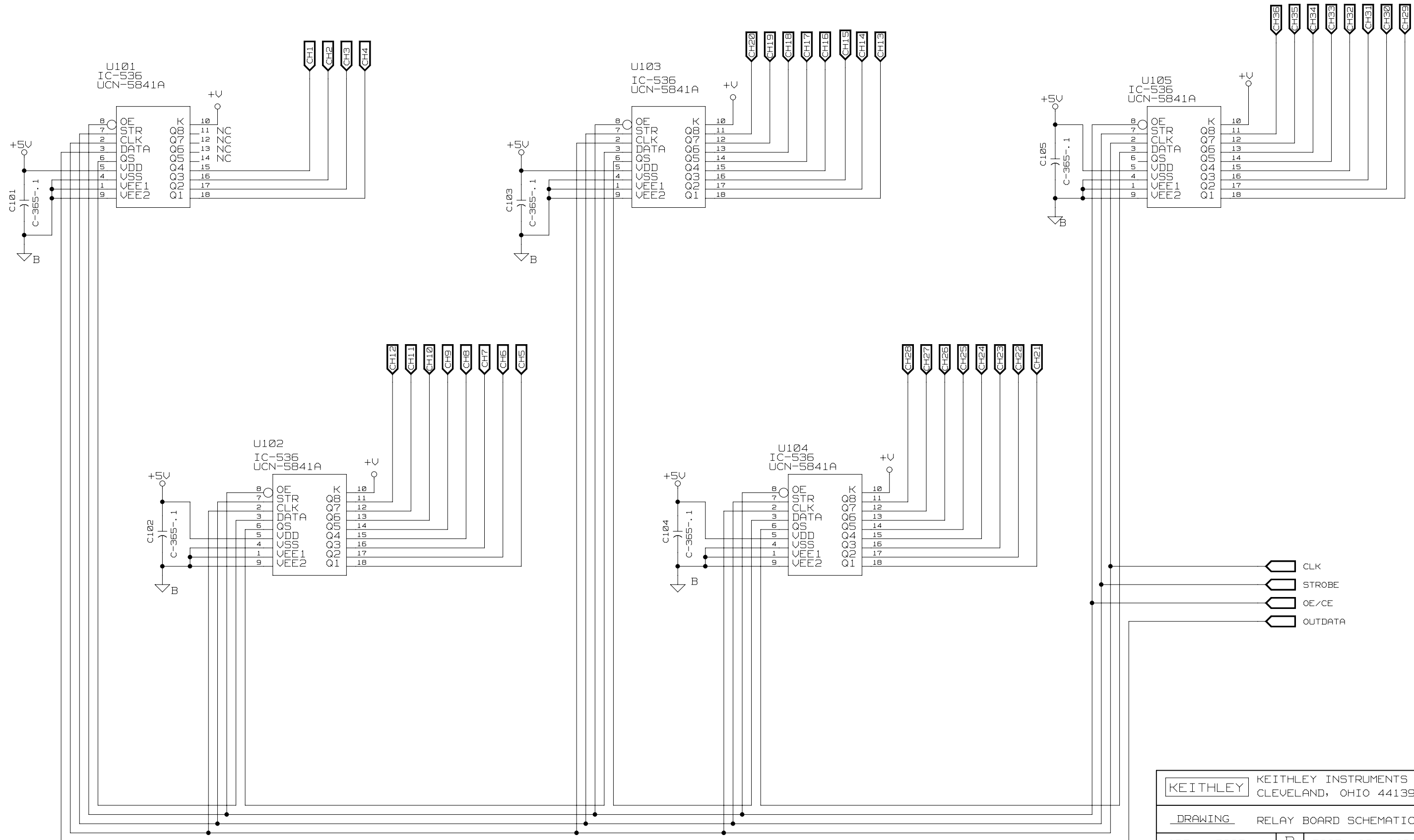

KEITHLEY		KEITHLEY INSTRUMENTS INC. CLEVELAND, OHIO 44139	
DRAWING		RELAY BOARD SCHEMATIC	
MODEL 7035	B	7035_106.LOGIC.1.2	
DRAWN ELS	APP	ECA 25918	REV C1
LAST_MODIFIED=Wed Jun 20 21:17:42 2001			

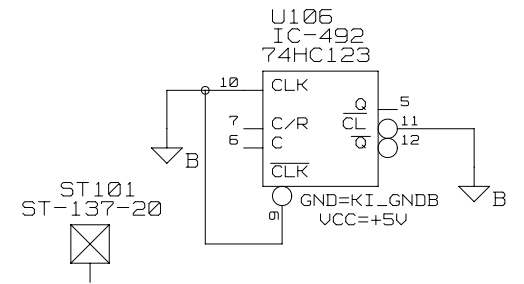
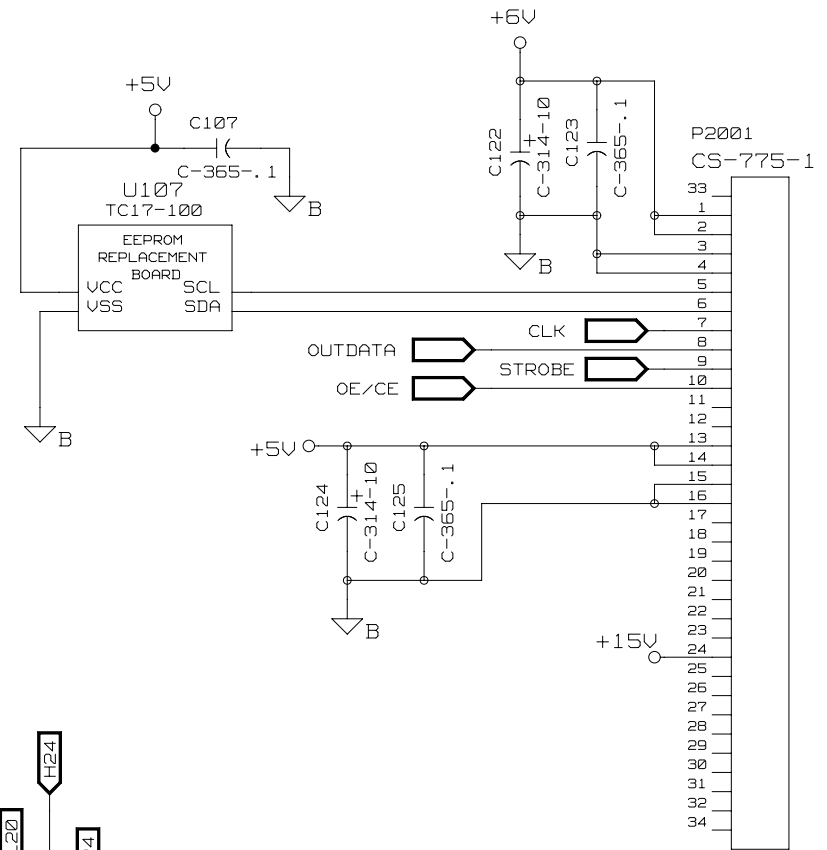
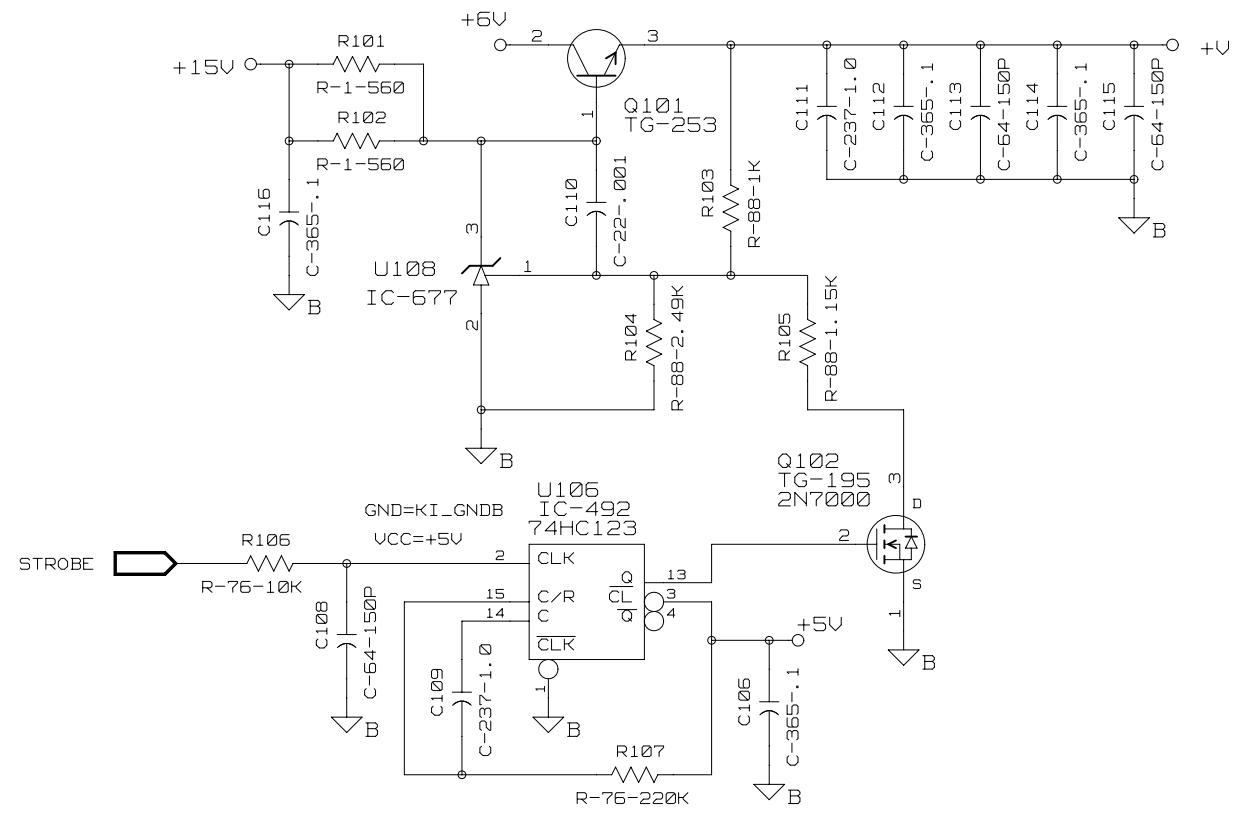
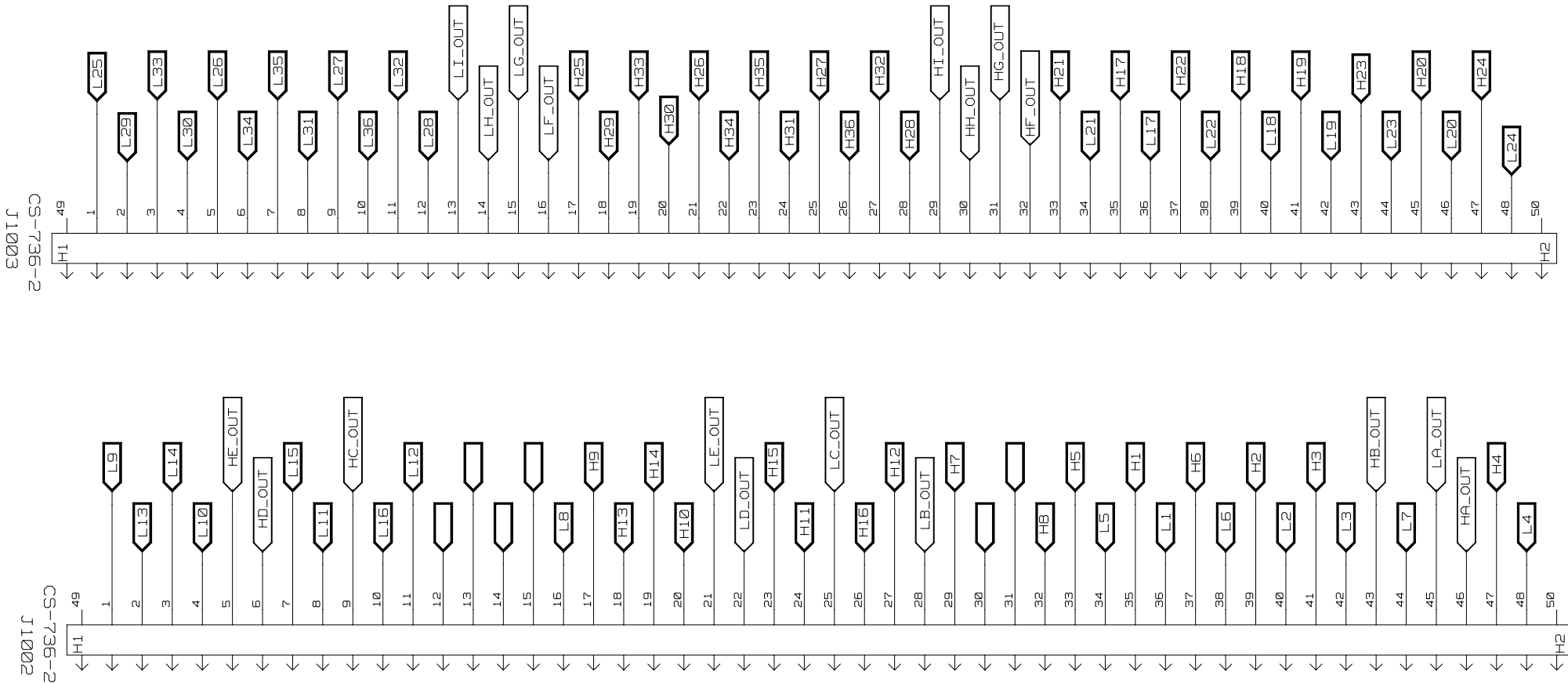

KEITHLEY KEITHLEY INSTRUMENTS INC. CLEVELAND, OHIO 44139			
DRAWING RELAY BOARD SCHEMATIC			
MODEL	7035	B	7035_106.LOGIC.1.3
DRAWN	ELS	APP	ECA 25918 REV C1
LAST_MODIFIED=Wed Jun 20 21:28:31 2001			

LTR.	ECA NO.	REVISION	ENG.	DATE
A				

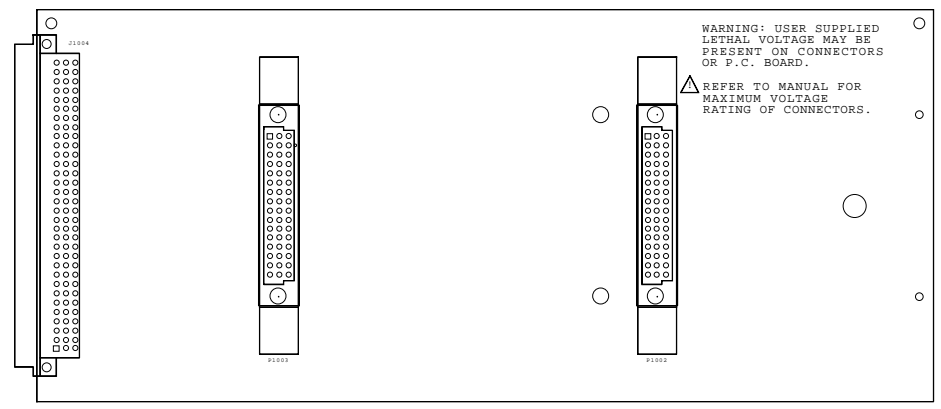

NOTE: FOR COMPONENT INFORMATION, PLEASE REFER TO PRODUCT STRUCTURE.

MODEL	NEXT ASSEMBLY	QTY.
USED ON		

KEITHLEY KEITHLEY INSTRUMENTS INC. CLEVELAND, OHIO 44139	DIM ARE IN IN. UNLESS OTHERWISE NOTED	DATE 2/18/97	SCALE 1:1	TITLE
	DIM. TOL. UNLESS OTHERWISE SPECIFIED	DRN CAB	APPR.	COMPONENT LAYOUT CONNECTOR BOARD
XX=+.01 XXX=+.005	ANG.=+1 FRAC.=+1/64	DO NOT SCALE THIS DRAWING	C	NO. 7035-170

4

3

2

1

0 7 3 5 - 1 7 0
ON

4

3

2

1

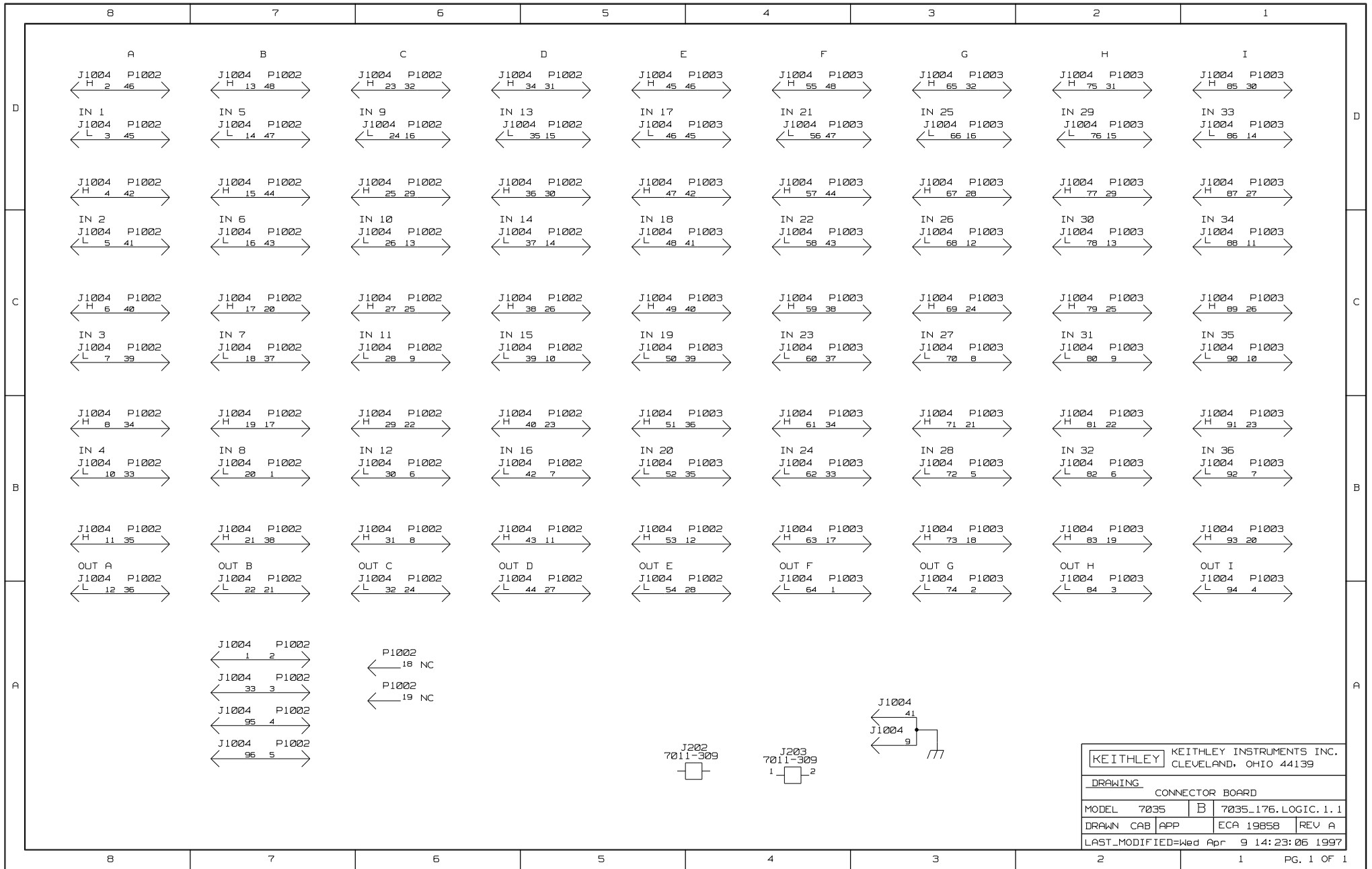

KEITHLEY		KEITHLEY INSTRUMENTS INC. CLEVELAND, OHIO 44139	
DRAWING CONNECTOR BOARD			
MODEL 7035	B	7035_176.LOGIC.1.1	
DRAWN CAB APP	ECA 19858	REV A	
LAST_MODIFIED=Wed Apr 9 14:23:06 1997			

Index

A

AC frequency response 5-14
Analog matrix maximum signal levels 5-1

B

Backplane jumpers 2-1
Backplane row jumpers 4-2
Basic matrix configuration (5 × 6) 2-1
Block diagram 6-11

C

Card connections and installation 4-1
Card installation 4-18
Card removal 4-18
Channel assignments 5-2
Channel functionality test 6-10
Channel resistance tests 6-3
Closing and opening channels 5-4
Common-emitter characteristics curves 5-12
Component layouts and schematic diagrams 7-1
Configuring digital I/O input pull-up resistance 4-4
Configuring digital I/O output logic 4-4
Contact potential tests 6-6
Controlling devices using pull-up resistors 3-2
Controlling pull-up devices 3-1

D

DC parameter checks 5-11
Differential and common-mode isolation test 6-8
Differential switching 2-3
Digital I/O configuration 3-1
Digital I/O connections 4-2
Digital I/O input channel control 6-13
Digital I/O maximum signal levels 5-1
Digital I/O output channel controls 6-13
Digital inputs 3-3
Digital outputs 3-1

E

Environmental conditions 6-2

F

Factory service 7-1
Features 1-1
Four-terminal ohms measurements 5-8

G

General information 1-1
Ground loops 5-14

H

Handling and cleaning
precautions 6-1
Handling precautions 1-2, 4-1

I

ID data circuits 6-12
IEEE-488 bus operation 5-5
Input channels 5-1
Input connection scheme 4-17
Inspection for damage 1-2
Instruction manual 1-2

J

Jumper installation 4-2
Jumper removal 4-2

K

Keeping connectors clean 5-14

M

Magnetic fields 5-13
Mainframe control of the card 5-1
Mainframe matrix expansion 2-8
Manual addenda 1-2
Matrix configuration 2-1
Matrix connections 4-2, 6-2
Matrix expansion 2-5
Matrix relay control 6-13
Matrix relay power control 6-13
Matrix switching examples 5-7
Measurement considerations 5-12
Mixing card types 2-8
Model 7022 installation and
removal 4-18
Multi-pin (mass termination)
connector card 4-5

N

Narrow matrix expansion (4×12
matrix) 2-6

O

Offset current tests 6-4
Operation 5-1
Optional accessories 1-3
Ordering information 7-1
Output channels 5-1
Output connection schemes 4-16

P

Partial matrix implementation 2-9
Parts lists 7-1
Path isolation 5-12
Path isolation tests 6-7
Performance verification 6-2
Power-on safeguard 6-13
Power limits 5-1
Principles of operation 6-11
Pull-up resistors 4-3

R

Radio frequency interference 5-13
Reading digital I/O input channels 5-6
Reading input channels 5-5
Recommended equipment 6-2
Repacking for shipment 1-3
Replaceable parts 7-1

S

Safety symbols and terms 1-2
Scanning channels 5-4
Scanning output channels 5-5
Sensing 2-4
Separate switching systems 2-5
Service information 6-1
Shipping contents 1-2
Single-card system 4-11
Single-ended switching 2-3
Special handling of static-sensitive
devices 6-11
SMU connections 2-4
Specifications 1-2

T

Thick film resistor network testing 5-7
Transistor testing 5-10
Troubleshooting 6-14
Troubleshooting access 6-14
Troubleshooting equipment 6-14
Troubleshooting procedure 6-14
Turning channels on and off 5-5
Two-card switching systems 2-5
Two-card system 4-12
Two-mainframe system 4-14
Typical connection techniques 4-8
Typical digital I/O connection schemes 4-16
Typical matrix connection schemes 4-11
Typical matrix switching schemes 2-2

U

Unpacking and inspection 1-2

V

Voltage divider checks 5-8
Voltage source jumper 4-2

W

Warranty information 1-2
Wide matrix expansion (10 × 6 matrix) 2-7



Service Form

Model No. _____ Serial No. _____ Date _____

Name and Telephone No. _____

Company _____

List all control settings, describe problem and check boxes that apply to problem. _____

- | | | |
|--------------------------------------------------|----------------------------------------------------------|--------------------------------------------------------------------|
| <input type="checkbox"/> Intermittent | <input type="checkbox"/> Analog output follows display | <input type="checkbox"/> Particular range or function bad; specify |
| <input type="checkbox"/> IEEE failure | <input type="checkbox"/> Obvious problem on power-up | <input type="checkbox"/> Batteries and fuses are OK |
| <input type="checkbox"/> Front panel operational | <input type="checkbox"/> All ranges or functions are bad | <input type="checkbox"/> Checked all cables |

Display or output (check one)

- | | |
|-----------------------------------|------------------------------------------------------|
| <input type="checkbox"/> Drifts | <input type="checkbox"/> Unable to zero |
| <input type="checkbox"/> Unstable | <input type="checkbox"/> Will not read applied input |
| <input type="checkbox"/> Overload | |

- | | |
|-------------------------------------------|--------------------------------------------------------------|
| <input type="checkbox"/> Calibration only | <input type="checkbox"/> Certificate of calibration required |
| <input type="checkbox"/> Data required | |

(attach any additional sheets as necessary)

Show a block diagram of your measurement system including all instruments connected (whether power is turned on or not). Also, describe signal source.

Where is the measurement being performed? (factory, controlled laboratory, out-of-doors, etc.)

What power line voltage is used? _____ Ambient temperature? _____ °F

Relative humidity? _____ Other? _____

Any additional information. (If special modifications have been made by the user, please describe.)

Be sure to include your name and phone number on this service form.



Keithley Instruments, Inc.

28775 Aurora Road
Cleveland, Ohio 44139

Printed in the U.S.A.