



**RSA7100A
Real-Time Signal Analyzer
Specifications and Performance Verification
Technical Reference**

This document applies to instruments running software version 3.11.0xxx or later.

Warning

The servicing instructions are for use by qualified personnel only. To avoid personal injury, do not perform any servicing unless you are qualified to do so. Refer to all safety summaries prior to performing service.

www.tek.com

077-1299-01

Copyright © Tektronix. All rights reserved. Licensed software products are owned by Tektronix or its subsidiaries or suppliers, and are protected by national copyright laws and international treaty provisions.

Tektronix products are covered by U.S. and foreign patents, issued and pending. Information in this publication supersedes that in all previously published material. Specifications and price change privileges reserved.

TEKTRONIX and TEK are registered trademarks of Tektronix, Inc.

Contacting Tektronix

Tektronix, Inc.
14150 SW Karl Braun Drive
P.O. Box 500
Beaverton, OR 97077
USA

For product information, sales, service, and technical support:

- In North America, call 1-800-833-9200.
- Worldwide, visit www.tek.com to find contacts in your area.

Warranty

Tektronix warrants that this product will be free from defects in materials and workmanship for a period of one (1) year from the date of shipment. If any such product proves defective during this warranty period, Tektronix, at its option, either will repair the defective product without charge for parts and labor, or will provide a replacement in exchange for the defective product. Parts, modules and replacement products used by Tektronix for warranty work may be new or reconditioned to like new performance. All replaced parts, modules and products become the property of Tektronix.

In order to obtain service under this warranty, Customer must notify Tektronix of the defect before the expiration of the warranty period and make suitable arrangements for the performance of service. Customer shall be responsible for packaging and shipping the defective product to the service center designated by Tektronix, with shipping charges prepaid. Tektronix shall pay for the return of the product to Customer if the shipment is to a location within the country in which the Tektronix service center is located. Customer shall be responsible for paying all shipping charges, duties, taxes, and any other charges for products returned to any other locations.

This warranty shall not apply to any defect, failure or damage caused by improper use or improper or inadequate maintenance and care. Tektronix shall not be obligated to furnish service under this warranty a) to repair damage resulting from attempts by personnel other than Tektronix representatives to install, repair or service the product; b) to repair damage resulting from improper use or connection to incompatible equipment; c) to repair any damage or malfunction caused by the use of non-Tektronix supplies; or d) to service a product that has been modified or integrated with other products when the effect of such modification or integration increases the time or difficulty of servicing the product.

THIS WARRANTY IS GIVEN BY TEKTRONIX WITH RESPECT TO THE PRODUCT IN LIEU OF ANY OTHER WARRANTIES, EXPRESS OR IMPLIED. TEKTRONIX AND ITS VENDORS DISCLAIM ANY IMPLIED WARRANTIES OF MERCHANTABILITY OR FITNESS FOR A PARTICULAR PURPOSE. TEKTRONIX' RESPONSIBILITY TO REPAIR OR REPLACE DEFECTIVE PRODUCTS IS THE SOLE AND EXCLUSIVE REMEDY PROVIDED TO THE CUSTOMER FOR BREACH OF THIS WARRANTY. TEKTRONIX AND ITS VENDORS WILL NOT BE LIABLE FOR ANY INDIRECT, SPECIAL, INCIDENTAL, OR CONSEQUENTIAL DAMAGES IRRESPECTIVE OF WHETHER TEKTRONIX OR THE VENDOR HAS ADVANCE NOTICE OF THE POSSIBILITY OF SUCH DAMAGES.

[W2 – 15AUG04]

Table of Contents

Important safety information	v
General safety summary	v
Service safety summary	vii
Terms in this manual	viii
Symbols and terms on the product	viii
Preface	ix
Related Manuals	ix
Specifications	1
Performance Conditions	2
Electrical Specifications	2
Electrical Functional Specifications	26
Physical Characteristics	39
Safety	41
Certifications and Compliances	41
Performance Verification	43
Prerequisites	43
Required Equipment	43
Preliminary Checks	45
Warranted characteristics tests	47
Frequency Accuracy	47
Amplitude	49
Noise and Distortion	52
Spurious Response	56
Test record	59

List of Figures

Figure 1: Connections for Reference Frequency Output Accuracy check	47
Figure 2: Power meter setup	48
Figure 3: Power meter calibration	48
Figure 4: Equipment connections for Ref Out power level check	49
Figure 5: Equipment connections for RF flatness check	49
Figure 6: Equipment connections for Third Order Intermodulation Distortion check.....	52
Figure 7: Equipment connections for Image Suppression check.....	57

List of Tables

Table 1: Specification categories	1
Table 2: Frequency range.....	2
Table 3: Frequency reference	2
Table 4: Phase noise (typical).....	3
Table 5: RF input	4
Table 6: Maximum RF input level.....	5
Table 7: Input attenuator.....	5
Table 8: Input preselector.....	5
Table 9: Amplitude and RF flatness (excluding mismatch error)	6
Table 10: Noise and distortion ¹	7
Table 11: Channel Response (Amplitude and Phase Flatness deviations), typical.....	8
Table 12: Residual spurious response	9
Table 13: Spurious response with signal at input	10
Table 14: Wideband extended tuning	12
Table 15: Trigger	12
Table 16: Real-time Event Minimum Duration for 100% probability of Trigger	14
Table 17: Real-time transforms per second.....	16
Table 18: Sweep speed.....	17
Table 19: Recording to RAID, nominal.....	17
Table 20: GPS location and timing	18
Table 21: Pulse measurements, typical.....	18
Table 22: Acquisition	25
Table 23: Amplitude vs. time, nominal	25
Table 24: Measurement function	26
Table 25: Views by domain	27
Table 26: General Purpose Analog modulation accuracy.....	28
Table 27: General purpose digital modulation analysis (Option SVM)	28
Table 28: Digital demodulation accuracy (Option SVM).....	29
Table 29: Adaptive equalizer.....	31
Table 30: OFDM measurement (Option SVO).....	31
Table 31: WLAN 802.11a/b/g/j/p Tx measurement (Option SV23).....	31
Table 32: WLAN 802.11n Tx measurement (Option SV24)	31
Table 33: WLAN 802.11ac Tx measurement (Option SV25H)	31
Table 34: P25 analysis (Option SV26).....	32
Table 35: Bluetooth® analysis (Option SV27).....	32
Table 36: LTE measurement	33
Table 37: ACLR measurement.....	33
Table 38: DPX spectrum processing	33

Table 39: OBW Measurement	34
Table 40: xdB Bandwidth Measurement.....	34
Table 41: Frequency Settling Time measurement (Option SVT)	34
Table 42: AM/FM/PM measurements.....	36
Table 43: Power requirements	39
Table 44: Environmental requirements	39
Table 45: Dynamics	39
Table 46: Physical characteristics (RSA7100A)	40
Table 47: Physical characteristics (CTRL7100A)	40
Table 48: Status indicators	40
Table 49: CTRL7100A PC characteristics.....	41
Table 50: Equipment required for Performance Verification	43
Table 51: RF Flatness (Preamp OFF, attenuator = 10 dB) for Band 100 MHz to 3.6 GHz	50
Table 52: RF Flatness (Preamp OFF, attenuator = 10 dB) for Band 3.6 GHz to 8.5 GHz.....	51
Table 53: RF Flatness (Preamp OFF, attenuator = 10 dB) for Band 8.5 GHz to 14 GHz	51
Table 54: RF Flatness (Preamp OFF, attenuator = 10 dB) for Band 14 GHz to 20 GHz	51
Table 55: RF Flatness (Preamp OFF, attenuator = 10 dB) for Band 20 GHz to 26.5 GHz.....	51
Table 56: Frequencies of interest for DANL (Preamp OFF)	54
Table 57: Frequencies of interest for DANL (Preamp ON).....	56
Table 58: Residual response center frequencies.....	57
Table 59: Image suppression settings	58

Important safety information

This manual contains information and warnings that must be followed by the user for safe operation and to keep the product in a safe condition.

To safely perform service on this product, additional information is provided at the end of this section. (See page vii, *Service safety summary*.)

General safety summary

Use the product only as specified. Review the following safety precautions to avoid injury and prevent damage to this product or any products connected to it. Carefully read all instructions. Retain these instructions for future reference.

Comply with local and national safety codes.

For correct and safe operation of the product, it is essential that you follow generally accepted safety procedures in addition to the safety precautions specified in this manual.

The product is designed to be used by trained personnel only.

Only qualified personnel who are aware of the hazards involved should remove the cover for repair, maintenance, or adjustment.

Before use, always check the product with a known source to be sure it is operating correctly.

This product is not intended for detection of hazardous voltages.

Use personal protective equipment to prevent shock and arc blast injury where hazardous live conductors are exposed.

While using this product, you may need to access other parts of a larger system. Read the safety sections of the other component manuals for warnings and cautions related to operating the system.

When incorporating this equipment into a system, the safety of that system is the responsibility of the assembler of the system.

To avoid fire or personal injury

Use proper power cord. Use only the power cord specified for this product and certified for the country of use.

Do not use the provided power cord for other products.

Ground the product. This product is grounded through the grounding conductor of the power cord. To avoid electric shock, the grounding conductor must be connected to earth ground. Before making connections to the input or output terminals of the product, make sure that the product is properly grounded.

Do not disable the power cord grounding connection.

Power disconnect. The power cord disconnects the product from the power source. See instructions for the location. Do not position the equipment so that it is difficult to operate the power cord; it must remain accessible to the user at all times to allow for quick disconnection if needed.

Observe all terminal ratings. To avoid fire or shock hazard, observe all ratings and markings on the product. Consult the product manual for further ratings information before making connections to the product. Do not exceed the Measurement Category (CAT) rating and voltage or current rating of the lowest rated individual component of a product, probe, or accessory. Use caution when using 1:1 test leads because the probe tip voltage is directly transmitted to the product.

Do not apply a potential to any terminal, including the common terminal, that exceeds the maximum rating of that terminal.

The measuring terminals on this product are not rated for connection to mains or Category II, III, or IV circuits.

Do not operate without covers. Do not operate this product with covers or panels removed, or with the case open. Hazardous voltage exposure is possible.

Avoid exposed circuitry. Do not touch exposed connections and components when power is present.

Do not operate with suspected failures. If you suspect that there is damage to this product, have it inspected by qualified service personnel.

Disable the product if it is damaged. Do not use the product if it is damaged or operates incorrectly. If in doubt about safety of the product, turn it off and disconnect the power cord. Clearly mark the product to prevent its further operation.

Examine the exterior of the product before you use it. Look for cracks or missing pieces.

Use only specified replacement parts.

Do not operate in wet/damp conditions. Be aware that condensation may occur if a unit is moved from a cold to a warm environment.

Do not operate in an explosive atmosphere.

Keep product surfaces clean and dry. Remove the input signals before you clean the product.

Provide proper ventilation. Refer to the installation instructions in the manual for details on installing the product so it has proper ventilation.

Slots and openings are provided for ventilation and should never be covered or otherwise obstructed. Do not push objects into any of the openings.

Provide a safe working environment. Always place the product in a location convenient for viewing the display and indicators.

Avoid improper or prolonged use of keyboards, pointers, and button pads. Improper or prolonged keyboard or pointer use may result in serious injury.

Be sure your work area meets applicable ergonomic standards. Consult with an ergonomics professional to avoid stress injuries.

Use care when lifting and carrying the product. This product is provided with handles for lifting and carrying.



WARNING. *The product is heavy. To reduce the risk of personal injury or damage to the device get help when lifting or carrying the product. Use a two-person lift or a mechanical aid.*

Use only the Tektronix rackmount hardware specified for this product.

Service safety summary

The *Service safety summary* section contains additional information required to safely perform service on the product. Only qualified personnel should perform service procedures. Read this *Service safety summary* and the *General safety summary* before performing any service procedures.

To avoid electric shock. Do not touch exposed connections.

Do not service alone. Do not perform internal service or adjustments of this product unless another person capable of rendering first aid and resuscitation is present.

Disconnect power. To avoid electric shock, switch off the product power and disconnect the power cord from the mains power before removing any covers or panels, or opening the case for servicing.

Use care when servicing with power on. Dangerous voltages or currents may exist in this product. Disconnect power, remove battery (if applicable), and disconnect test leads before removing protective panels, soldering, or replacing components.

Verify safety after repair. Always recheck ground continuity and mains dielectric strength after performing a repair.

Terms in this manual

These terms may appear in this manual:



WARNING. *Warning statements identify conditions or practices that could result in injury or loss of life.*



CAUTION. *Caution statements identify conditions or practices that could result in damage to this product or other property.*

Symbols and terms on the product

These terms may appear on the product:

- **DANGER** indicates an injury hazard immediately accessible as you read the marking.
- **WARNING** indicates an injury hazard not immediately accessible as you read the marking.
- **CAUTION** indicates a hazard to property including the product.



When this symbol is marked on the product, be sure to consult the manual to find out the nature of the potential hazards and any actions which have to be taken to avoid them. (This symbol may also be used to refer the user to ratings in the manual.)

The following symbol(s) may appear on the product:

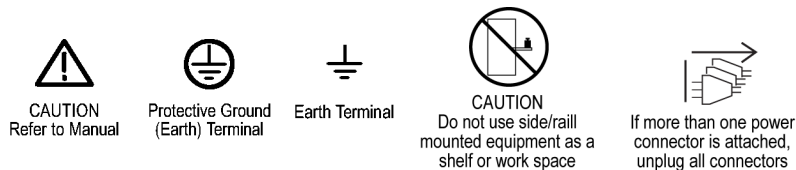

Preface

This document contains the Specifications and the Performance Verification for the RSA7100A Real-Time Spectrum Analyzer. It contains procedures suitable for determining that the analyzer functions, is adjusted properly, and meets the performance characteristics as warranted.

Related Manuals

The following documents relate to the operation of the analyzer:

- The *RSA7100A Real-Time Spectrum Analyzer Quick Start User Manual* provides installation, setup, and basic operating information.
- The *SignalVu-PC Vector Signal Analysis Software Help* provides detailed information about how to use the measurements and capabilities of the application with the RSA7100A. This is available in the instrument UI and on the web as a PDF at www.Tek.com.
- The *SignalVu-PC Programmer Manual* describes how to use a computer to control the application and RSA7100A through the remote commands.
- The *RSA7100A Real-Time Spectrum Analyzer Specifications and Performance Verification Technical Reference* provides specifications and performance verification procedures for the RSA7100A.

Specifications

This section contains specifications for the RSA7100A Real-Time Spectrum Analyzer. All specifications are warranted unless noted as a typical specification.

Table 1: Specification categories

Category	Description
Specified Characteristics	These are the warranted characteristics of the device, and are tested either on each unit in manufacturing or by type-testing. Specified characteristics include measurement tolerance and temperature limits.
Typical	This is performance that will be met by 80% of measured values meeting the specification with 80% confidence, for ambient temperatures in the range of 18 °C to 28 °C, immediately after performing a full alignment. Values include the effects of the uncertainties of external calibration references and aging over the course of the published calibration interval. These values are determined from qualification testing and are not warranted or tested in the performance verification.
Typical-95	This is performance that will be met by 95% of instruments with 95% confidence, for ambient temperatures in the range of 18 °C to 28 °C, immediately after performing an alignment. Values include the effects of the uncertainties of external calibration references and aging over the course of the recommended calibration interval. These values are determined from qualification testing and are not warranted or tested in the performance verification.
Typical-mean	This represents the mean of performance measured on a sample of units. Sample data is collected at laboratory temperature, immediately after performing an alignment. Values do not include the effects of uncertainties of external calibration references and aging over the course of the recommended calibration interval. These values are determined from qualification testing and are not warranted or tested in the performance verification.
Nominal	Guaranteed by design. Characteristics do not have tolerance limits.

Specifications that are marked with the ✓ symbol are checked in the Performance Verification section.

Performance Conditions

The performance limits in these specifications are valid with these conditions:

- The signal analyzer must have been calibrated and adjusted at an ambient temperature between +18 °C (+64 °C) and +28 °C (+82 °C).
- The signal analyzer must be in an environment with temperature, altitude, humidity, and vibration within the operating limits described in these specifications.
- The signal analyzer must have had a warm-up period of at least 30 minutes after starting the RSA7100A application and at the operating temperature.

Power sequence

The converter unit (RSA7100A) must be plugged in prior to powering up the controller (CTRL7100A). If the converter is disconnected from power, or otherwise becomes nonresponsive, the controller must be powered down and restarted to reset the converter. It is not sufficient to use the Windows “Restart” function; the controller must be powered down with the Windows “Shutdown” function or equivalent.

Electrical Specifications

Table 2: Frequency range

Characteristic	Description
Frequency range	With preamp on or auto, the RSA7100A may be tuned or swept to frequencies > 3.6 GHz, but the preamp will only be on for frequencies ≤ 3.6 GHz.
Preamp off	16 kHz to 14 GHz (RSA7100A Opt 14) 6 kHz to 26.5 GHz (RSA7100A Opt 26)
Preamp on	10 MHz to 3.6 GHz
Tuning resolution	1x10 ⁻³
Frequency marker readout accuracy	±(RE x MF + 0.001 x Span) Hz RE: Reference Frequency Error MF: Marker Frequency [Hz]

Table 3: Frequency reference

Characteristic	Description
Frequency	10 MHz
Initial accuracy at Cal (10 min warmup), ✓	± 50 x 10 ⁻⁹ , 23 °C to 28 °C
Aging After 30 days of continuous operation, typical	± 0.5 x 10 ⁻⁹ per day ± 100 x 10 ⁻⁹ first year

Table 3: Frequency reference (cont.)

Characteristic	Description
Cumulative Error (Initial + Temperature + Aging), typical	200×10^{-9} (1 year)
Temperature drift, ✓	$\pm 10 \times 10^{-9}$ (23 °C to 28 °C) $\pm 50 \times 10^{-9}$ (0 °C to 55 °C)
External reference output	BNC connector, 50 Ω nominal
External reference output level ✓	0.71 Vpp to 2 Vpp into 50 Ω
External reference output level, typical	1.2 Vpp into 50 Ω
External reference input	BNC connector, 50 Ω nominal
External reference input frequency	10 MHz $\pm 0.2 \times 10^{-6}$
External reference input level	0.5 Vpp to 2 Vpp into 50 Ω

Table 4: Phase noise (typical)

Characteristic	Description	Offset
Frequency = 1 GHz (Typical, mean)	-115 dBc/Hz	100 Hz
	-128 dBc/Hz	1 kHz
	-134 dBc/Hz	10 kHz
	-132 dBc/Hz	100 kHz
	-142 dBc/Hz	1 MHz
Frequency = 5 GHz	-114 dBc/Hz	100 Hz
	-127 dBc/Hz	1 kHz
	-133 dBc/Hz	10 kHz
	-131 dBc/Hz	100 kHz
	-141 dBc/Hz	1 MHz
Frequency = 10 GHz	-109 dBc/Hz	100 Hz
	-122 dBc/Hz	1 kHz
	-128 dBc/Hz	10 kHz
	-125 dBc/Hz	100 kHz
	-136 dBc/Hz	1 MHz

Table 4: Phase noise (typical) (cont.)

Characteristic	Description	Offset
Frequency = 20 GHz	-103 dBc/Hz	100 Hz
	-116 dBc/Hz	1 kHz
	-122 dBc/Hz	10 kHz
	-120 dBc/Hz	100 kHz
	-130 dBc/Hz	1 MHz

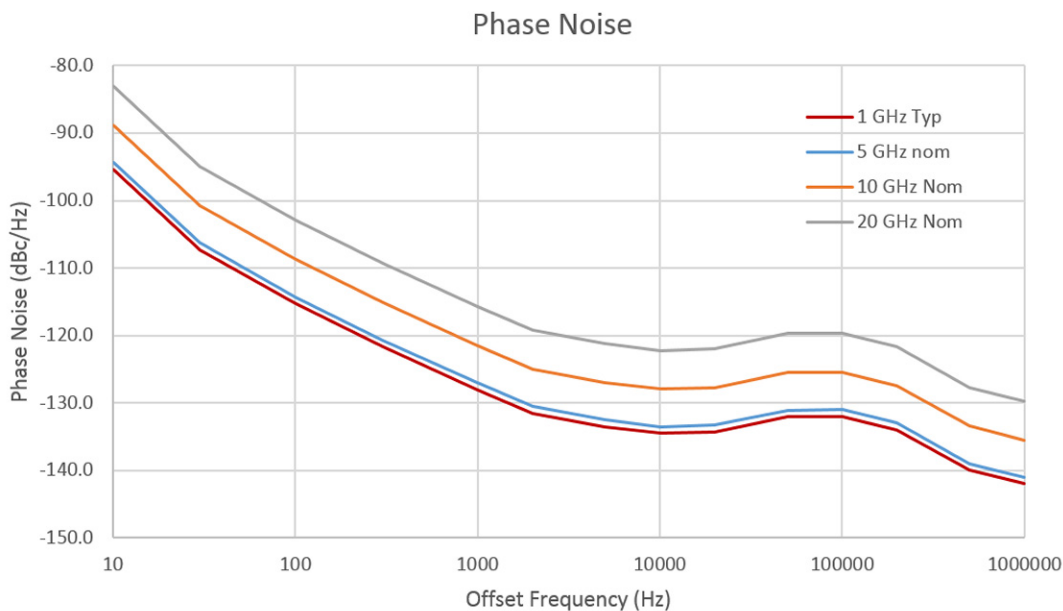

Table 5: RF input

Characteristic	Description
RF Input Impedance	50 Ω
RF VSWR, typical	<1.5 (10 MHz to 14 MHz)
(RF Attn ≥ 10 dB)	<1.7 (>14 MHz to 26.5 GHz)

Table 6: Maximum RF input level

Characteristic	Description
Maximum DC voltage	±40 V (RF Input)
Maximum safe input power	+30 dBm
Maximum measurable input power	+30 dBm ADC and IF overload are detected and the user is informed and streaming data is flagged, but not stopped. Furthermore, an IF overload will initiate a protection event that will switch out the input signal. If SignalVu-PC is acquiring samples when this occurs, SignalVu-PC will automatically reset the switch periodically so that if the overload condition goes away, the input will continue to be sampled normally.

Table 7: Input attenuator

Characteristic	Description
RF Attenuator	0 dB to 100 dB (in 1 dB steps), 16 kHz to 3.6 GHz 0 dB to 75 dB (in 5 dB steps), 3.6 GHz to 26.5 GHz

Table 8: Input preselector

Acquisition mode	Preselector mode	Preselector On	Preselector Off
Swept, 50 MHz steps	On	On	Step CF ≤ 3.6 GHz: On Step CF > 3.6 GHz: Off
Swept, 320 MHz steps	NA	NA	Step CF ≤ 3.41 GHz: On Step CF > 3.41 GHz: Off
Real-Time span ≤ 50 MHz	On	On	CF ≤ 3.6 GHz: On CF > 3.6 GHz: Off
Real-Time span > 50 MHz	CF ≤ 3.41 GHz: On CF > 3.41 GHz: Off	NA	CF ≤ 3.41 GHz: On CF > 3.41 GHz: Off

The preselector is input filters used for image suppression when the span of the instrument allows for its use. Two methods of preselection are used in the RSA7100A: a fixed low-pass filter (LPF) and a tunable bandpass filter (BPF).

Due to the narrow-band nature of the tuned BPF, it is necessary to bypass this filter for wideband analysis of signals with bandwidth >50 MHz. The tuned BPF preselector is enabled depending on the acquisition mode (swept or real-time), frequency range, and user selection of preselector state as described in the table. The LPF preselector is naturally wideband, so that filter is always present, even when the preselector “Off” mode is manually selected.

Swept Acq Mode is enabled when the span is greater than the maximum allowed acquisition BW. In swept mode, the frequency range is spanned in discrete steps of 50 MHz or 320 MHz depending on the state of the preselector.

Table 9: Amplitude and RF flatness (excluding mismatch error)

Characteristic	Description			
Reference level setting range	-170 dBm to +40 dBm, 0.1 dB step			
Frequency response (18 °C to 28 °C) ✓	Alignment run prior to testing. Span ≤ 100 MHz; For CF < 100 MHz, specifications apply for Ref Level ≥ - 40 dBm; Verified with input level of -20 to -15 dBm; Ref level = -15 dBm, 10 dB RF attenuation, all settings auto-coupled; Signal to noise ratios > 40 dB.			
	Center frequency range	18 °C to 28 °C ✓	18 °C to 28 °C (typical)	0 °C to 55 °C (typical)
At 10 dB RF attenuator setting (Preamp Off)	10 MHz to <100 MHz	—	±0.11 dB	—
	100 MHz to <2.8 GHz	±0.16 dB	±0.13 dB	±0.18 dB
	2.8 GHz to 3.6 GHz	±0.16 dB	±0.13 dB	±0.38 dB
At 10 dB RF attenuator setting (Preamp On)	10 MHz to <100 MHz	—	±0.2 dB	—
	100 MHz to <2.8 GHz	±0.20 dB	±0.14 dB	±0.10 dB
	2.8 GHz to 3.6 GHz	±0.20 dB	±0.14 dB	±0.26 dB
Absolute amplitude accuracy at all center frequencies (18 °C to 28 °C) ✓	Alignment run prior to testing. Span ≤ 100 MHz; For CF < 100 MHz, specifications apply for Ref Level ≥ - 40 dBm; Verified with input level of 0 to -10 dBm below ref level; 10 dB RF attenuation, all settings auto-coupled; Signal to noise ratios > 40 dB.			
	Center frequency range	18 °C to 28 °C ✓	18 °C to 28 °C (typical)	0 °C to 55 °C (typical)
At -10 dB ref level, 100 MHz span, preselector bypassed (Preamp Off)	10 MHz to <100 MHz	—	±0.3 dB	—
	100 MHz to 3.6 GHz	±0.8 dB	±0.4 dB	±0.8 dB
	3.6 GHz to 8.5 GHz	±0.9 dB	±0.4 dB	±1.1 dB
	8.5 GHz to 14 GHz	±1.0 dB	±0.5 dB	±1.4 dB
	14 GHz to 20 GHz	±1.7 dB	±1.0 dB	±1.7 dB
	20 GHz to 26.5 GHz	±2.0 dB	±1.2 dB	±2.2 dB
At -30 dB ref level, 100 MHz span, (Preamp On)	10 MHz to <100 MHz	—	±0.4 dB	—
	100 MHz to 3.6 GHz	±1.2 dB	±0.6 dB	±1.2 dB
At -10 dB ref level, 50 MHz span, preselector enabled (Preamp On)	3.6 GHz to 8.5 GHz	±1.6 dB	±0.8 dB	±1.7 dB
	8.5 GHz to 14 GHz	±1.5 dB	±0.7 dB	±1.5 dB
	14 GHz to 20 GHz	±2.6 dB	±1.3 dB	±2.2 dB
	20 GHz to 26.5 GHz	±2.8 dB	±1.5 dB	±2.2 dB

Table 10: Noise and distortion ¹

Characteristic	Description
3rd Order IM Intercept	2-tone signal level -20 dBm per tone at the RF input. 1 MHz tone separation. Attenuator = 0 dB, Ref Level = -10 dBm. 5 MHz span, RBW set so noise is 10 dB below the IM3 tone level or lower. Production tested in a verification mode not part of normal operation.
	3.3 GHz, Preamp Off +24 dBm
3rd Order IM Intercept (TOI), typical	2-tone signal level -20 dBm per tone at the RF input. 1 MHz tone separation. Attenuator = 0 dB, Ref Level = -10 dBm. 5 MHz span, RBW set so noise is 10 dB below the IM3 tone level or lower.
	10 MHz to 3.6 GHz, Preamp On -12 dBm
	10 MHz to 100 MHz, Preamp Off +19 dBm
	100 MHz to 3.6 GHz, Preamp Off +24 dBm
	3.6 GHz to 7.5 GHz +20 dBm
	7.5 GHz to 14 GHz +27 dBm
	14 GHz to 26.5 GHz +21 dBm
3rd Order Intermodulation Distortion, typical	Preamp OFF, Preselector Off, 320 MHz acquisition bandwidth. 2-tone signal level -20 dBm per tone at the RF input. 50 MHz tone separation. Attenuator = 0 dB, Ref Level = -10 dBm.
	100 MHz to 3.4 GHz -85 dBc
	3.4 GHz to 6 GHz -65 dBc
	6 GHz to 26.5 GHz -80 dBc
2 nd Harmonic Intercept, typical	Preselector Enabled, Preamp Off. 0 dBm CW at the RF input. Attenuator = 10 dB, Ref Level = 0 dBm. Span 50 ≤ MHz
	100 MHz to 3.4 GHz input signal +40 dBm
	3.4 GHz to 6 GHz input signal +74 dBm
	1.8 GHz to 13.25 GHz input signal +68 dBm
Displayed Average Noise Level (DANL) 	Normalized to 1 Hz RBW with log-average detector, 0 dB attenuation, ref level -50 dBm. Preamp OFF, Preselector bypassed, 18 °C to 28 °C.
	>10 MHz to 1.7 GHz -153 dBm/Hz
	>1.7 GHz to 2.8 GHz -150 dBm/Hz
	>2.8 GHz to 3.6 GHz -148 dBm/Hz
	>3.6 GHz to 14 GHz -152 dBm/Hz
	>14 GHz to 17 GHz -145 dBm/Hz
	>17 GHz to 24 GHz -150 dBm/Hz
	>24 GHz to 26.5 GHz -146 dBm/Hz

Table 10: Noise and distortion ¹ (cont.)

Characteristic	Description
Displayed Average Noise Level (DANL), typical	Preamp Off, Preselector Off. Normalized to 1 Hz RBW, with log-average detector, 0 dB attenuation.
	200 kHz to 10 MHz -153 dBm/Hz
	10 MHz to 100 MHz -155 dBm/Hz
	100 MHz to 1.7 GHz -156 dBm/Hz
	1.7 GHz to 2.8 GHz -154 dBm/Hz
	2.8 GHz to 3.6 GHz -151 dBm/Hz
	3.6 GHz to 14 GHz -156 dBm/Hz
	14 GHz to 24 GHz -152 dBm/Hz
	24 GHz to 26.5 GHz -150 dBm/Hz
Displayed Average Noise Level (DANL) ✓	Preamp Off, Preselector bypassed, 18 °C to 28 °C. Normalized to 1 Hz RBW, with log-average detector, 0 dB attenuation, ref level -50 dBm.
	10 MHz to 50 MHz -163 dBm/Hz
	50 MHz to 1.7 GHz -164 dBm/Hz
	>1.7 GHz to 3.6 GHz -162 dBm/Hz
Displayed Average Noise Level (DANL), typical	Preamp On. Normalized to 1 Hz RBW, with log-average detector, 0 dB attenuation.
	10 MHz to 100 MHz -168 dBm/Hz
	100 MHz to 1.7 GHz -167 dBm/Hz
	1.7 GHz to 3.6 GHz -165 dBm/Hz
	Preselector Enabled. Normalized to 1 Hz RBW, with log-average detector, 0 dB attenuation, ref level -50 dBm.
	3.6 GHz to 14 GHz -152 dBm/Hz
	14 GHz to 26.5 GHz -147 dBm/Hz

¹ All noise and distortion measurements are made with Preamp Off except where noted.

Table 11: Channel Response (Amplitude and Phase Flatness deviations), typical

Characteristic		Description			
Measurement center frequency	Span (MHz)	Amplitude flatness (dBrms)	Phase linearity (degrees rms)	Amplitude flatness (dB)	Phase linearity (degrees)
10 MHz to 3.6 GHz (CF ≥ Span)	10	0.06	±0.8	0.08	±0.1
	25	0.15	±0.2	0.4	±0.5
	50	0.2	±0.3	1.0	±1.3
	100	0.4	±0.6	2.5	±3.5
	320	1.0	±1.4	10	±13

Table 11: Channel Response (Amplitude and Phase Flatness deviations), typical (cont.)

Characteristic		Description			
Measurement center frequency	Span (MHz)	Amplitude flatness (dBrms)	Phase linearity (degrees rms)	Amplitude flatness (dB)	Phase linearity (degrees)
3.6 GHz to 26.5 GHz	10		±0.50 dB	0.40 dB	±0.1
	25		±0.50 dB	0.40 dB	±0.5
	50		±0.40 dB	0.30 dB	±1.1
	100				±1.8
	320				±8
	800				±16

¹ For these specifications, set Preselector as Off, Attenuator to 10 dB, 18 °C to 28 °C.

Table 12: Residual spurious response

Characteristic	Description	
Residual response (100 MHz span) ¹	100 MHz to 3.6 GHz	<-99 dBm
	>3.6 GHz to 11 GHz	<-102 dBm
	>11 GHz to 14 GHz	<-86 dBm
	>14 GHz to 24 GHz, Option 26	<-86 dBm
	>24 GHz to 26.5 GHz, Option 26	<-84 dBm
Residual response (5 MHz span), typical ²	100 MHz to 3.6 GHz	<-115 dBm
	3.6 GHz to 11 GHz	<-115 dBm
	11 GHz to 14 GHz	<-105 dBm
	14 GHz to 24 GHz	<-105 dBm
	24 GHz to 26.5 GHz	<-95 dBm
Residual response (320 MHz span), typical ³	100 MHz to 3.6 GHz	<-110 dBm
	3.6 GHz to 11 GHz	<-105 dBm
	11 GHz to 14 GHz	<-85 dBm
	14 GHz to 26.5 GHz	<-85 dBm
Residual response (800 MHz span), typical ⁴	3.6 GHz to 14 GHz	<-85 dBm
	14 GHz to 20 GHz	<-85 dBm
	20 GHz to 26.5 GHz	<-75 dBm

¹ These are not related to input signals. Measured with input terminated, 100 MHz span, 0 dB attenuation, Ref= -60 dBm, preamp off, preselector bypassed at >3.6 GHz, 18 °C to 28 °C.

² These are not related to input signals. Span ≤ 5 MHz Measured with input terminated, 5 MHz span, 0 dB attenuation, ref = -60 dBm, preamp off.

³ These are not related to input signals. Measured with input terminated, 320 MHz span, 0 dB attenuation, preamp off, ref = -60 dBm, preselector bypassed.

⁴ These are not related to input signals. Measured with input terminated, 800 MHz span, 0 dB attenuation, preamp off, ref = -60 dBm, preselector bypassed.

Table 13: Spurious response with signal at input

Characteristic	Center frequency	Value
Spurious response with image signal (18 °C to 28 °C) ¹ ✓	100 MHz to 3.6 GHz (Input at CF + 9.225 GHz)	<-98 dBc
	>3.6 GHz to 11 GHz (Input at CF + 1.225 GHz)	<-81 dBc
	>11 GHz to 14 GHz (Input at CF + 1.225 GHz)	<-74 dBc
Spurious response with signal at CF (spur offset > 2.5 MHz), typical ²	100 MHz to 3.6 GHz (Span = 320 MHz)	<-80 dBc
	3.2 GHz to 3.55 GHz (Span = 320 MHz)	<-65 dBc
	3.6 GHz to 14 GHz (Span = 320 MHz)	<-85 dBc
	14 GHz to 26.5 GHz (Span = 320 MHz)	<-80 dBc
	> 3.6 GHz to 14 GHz (Span = 800 MHz)	<-65 dBc
	14 GHz to 26.5 GHz (Span = 800 MHz)	<-65 dBc
Spurious response with signal at CF (50 kHz ≤ spur offset < 2.5 MHz), typical ³	100 MHz to 3.6 GHz (except 3.38 - 3.39 GHz)	<-80 dBc
	3.38 GHz to 3.39 GHz	<-70 dBc
	3.6 GHz to 14 GHz	<-75 dBc
	14 GHz to 26.5 GHz	<-65 dBc
Spurious response with signal within capture bandwidth at other than CF (Span = 320 MHz), typical ⁴	100 MHz to 3.6 GHz (except 3.2 - 3.55 GHz)	<-80 dBc
	3.04 GHz to 3.6 GHz (signal at 3.2 to 3.55 GHz)	<-65 dBc
	3.6 GHz to 14 GHz	<-85 dBc
	14 GHz to 26.5 GHz	<-80 dBc
Spurious response with signal within capture bandwidth at other than CF (Span = 800 MHz), typical mean ^{4, 5}	3.6 GHz to 26.5 GHz	<-65 dBc
Spurious response with signal outside span (except for signal frequencies specified here) (Span ≤ 50 MHz), typical ⁶	100 MHz to 3.6 GHz	<-80 dBc
	3.6 GHz to 26.5 GHz	<-80 dBc

Table 13: Spurious response with signal at input (cont.)

Characteristic	Center frequency	Value
Spurious response due to signal applied at CF+1225 MHz to CF+1250 MHz and 2290 MHz to 2320 MHz, typical ⁷	100 MHz to 2.5 GHz	<-55 dBc
Spurious response due to signal applied at 160 MHz to 215 MHz and 3360 MHz to 3415 MHz, typical	100 MHz to 3.6 GHz	<-65 dBc
Spurious response due to signal applied at 585 MHz to 640 MHz and 4585 MHz to 4640 MHz, typical ⁷	100 MHz to 3.6 GHz	<-70 dBc
Local oscillator feed-through to input connector (Attenuator = 10 dB), typical	≤ 3.6 GHz	<-110 dBm (preamp off)
	>3.6 GHz	<-60 dBm (preselector enabled)

¹ Input level = 0 dBm, ref level = 0 dBm. RF atten = 10 dB. 50 MHz span, preselector enabled.

² These are not related to input signals. Span ≤ 5 MHz Measured with input terminated, 5 MHz span, 0 dB attenuation, ref = -60 dBm, preamp off.

³ Input level = -10 dBm, ref level = -10 dBm. RF atten = 10 dB. Span = 5 MHz, preselector enabled.

⁴ Ref Level = -10 dBm, RF atten = 10 dB, input level = -10 dBm. Because the preselector is bypassed, signals applied outside capture bandwidth may generate larger inband spurs.

⁵ The mean is taken from the largest spur within the span at each CF step and each input frequency stepped across the span. The input signal is stepped at 80 MHz/step across the span and the CF is stepped at 800 MHz/step across the specified frequency range. If a particular span and input combination has no spurs > -70 dBc it is not included in the mean so it does not contribute to reducing the mean.

⁶ Input level = -30 dBm, ref level = -30 dBm, RF atten = 10 dB. Span ≤ 50 MHz, preselector enabled.

⁷ Input level = -10 dBm, ref level = -10 dBm. RF atten = 10 dB. Span ≤ 50 MHz.

Table 14: Wideband extended tuning

Characteristic	Description
Frequency response at 18° C to 28° C (Preamp OFF), typical	±4.0 dB (3.2 GHz to 3.6 GHz) (Verified with input level of -20 to -15 dBm, Ref level = -15 dBm, 10 dB RF attenuation, all settings auto-coupled.) (Span >320 MHz. Signal to noise ratios >40 dB.)
Channel response at 18° C to 28° C, typical	Measurement CF = 3.2 GHz to 3.6 GHz Span = 800 MHz Amplitude flatness = 1.0 dBrms Amplitude flatness = ±4.0 dB (RF attenuation = 10 dB. Preselector bypassed.)
Residual response, typical	< -105 dBm (3.2 GHz to 3.6 GHz) (These are not related to input signals. Span = 800 MHz. Ref level = -60 dBm. Measured with input terminated, 0 dB attenuation, preamp off.)

Table 15: Trigger

Characteristic	Description
Trigger mode, type, and source, nominal	Modes: Free Run (Triggered by the end of the preceding acquisition) Triggered (Triggered by Event) Types: Single (one acquisition from one trigger) Continuous (repeated acquisitions from repeating triggers) Sources: RF Input (downconverted to IQ) Trigger Input Host (trigger initiated by host)
Trigger event types	Power level within span (RF Input) Frequency mask (Host) Host request (Host) Trigger edge (Trigger Input) DPX Density (Host)
Trigger GPS time stamp, typical	< 15 ns relative to GPS time GPS satellites may have error up to ±90 ns relative to UTC
Pre/Post Trigger Setting, nominal	Trigger Position is settable within 1% to 99% of Total Data Length
Power Trigger Level Range, nominal	30 dBm to -170 dBm
Power Trigger Level Resolution, nominal	0.1 dB

Table 15: Trigger (cont.)

Characteristic	Description
Power Trigger Level Accuracy, typical	± 1 dB (level ≥ -50 dB from Reference Level) for trigger levels >30 dB above the noise floor at the center frequency Instrument center frequency = ≥ 100 MHz This applies when the Trigger Level is between 10% and 90% of the signal amplitude. This specification is in addition to the overall amplitude accuracy uncertainty for spectrum analyzer mode.
Power Trigger Position Timing Uncertainty, typical	± 8 ns
Power Trigger Bandwidth setting, nominal	Not an independent setting. This is set by the "Time Domain Bandwidth" control. Power Trigger Bandwidth is determined by Acq BW.
Power Trigger Minimum Event Duration, nominal	4 ns
Frequency Mask Trigger Mask Point Horizontal Resolution, nominal	$<0.13\%$ of span
Frequency Mask Trigger Level Range, nominal	0 to -80 dB from reference level
Frequency Mask Trigger Level Resolution, nominal	0.1 dB
Frequency Mask Trigger Level Accuracy (with respect to Reference Level)	\pm (Channel Response Flatness + 2.5 dB) for mask levels ≥ -50 dB and >30 dB above the noise floor
Frequency Mask Trigger Timing Uncertainty, nominal	$\pm(0.5 * \text{Spectrum time})$
External Trigger Threshold Voltage, nominal	3.3 V TTL, VIL 0.8 V, VIH 2.0 V
External Trigger Input Impedance, nominal	10 k Ω
External Trigger Minimum Pulse Width, nominal	>10 ns
External Trigger Timing Uncertainty, nominal	± 8 ns
DPX Density Trigger Area of Interest Range, nominal	2 to 801 pixels (horizontal) x 2 to 201 pixels (vertical)

Table 16: Real-time Event Minimum Duration for 100% probability of Trigger

Characteristic	Description		Minimum signal duration for 100% probability of intercept at 100% amplitude (μsec)					
	Span (MHz)	RBW (kHz)	FFT length (ns/points)	DPX Spectrum	DPXogram	Freq mask trigger	Density trigger	
Real-time Event Minimum Duration for 100% probability of Trigger, typical	800	50000	38 / 256	0.419	0.844	0.419	0.946	
		20000	95 / 256	0.516	0.947	0.572	1.025	
		10000	190 / 256	0.686	1.115	0.768	1.164	
		1000	1,900 / 2,048	3.006	4.071	3.483	3.377	
		300	6,333 / 8,192	11.836	15.412	12.654	12.008	
		100	19,000 / 32,768	45.031	60.086	52.755	46.581	
		30	63,333 / 65,536	131.352	166.418	140.185	130.031	
		25	76,000 / 132,072	212.109	268.897	227.644	212.050	
		1	1,900,000 / 2,097,152	3824	3831	4154	3733	
		0.12	15,833,333 / 16,777,216	42120	42269	44721	41520	
		320	32,000	60 / 256	0.431	0.860	0.469	0.678
			20,000	94 / 256	0.476	0.908	0.517	0.684
			10,000	190 / 256	0.600	1.042	0.651	0.813
			1,000	1,900 / 1,024	2.685	3.229	2.870	2.754
300	6,334 / 4,096		9.156	10.962	10.208	9.778		
100	19,000 / 16,384		32.464	40.156	37.425	33.908		
30	63,334 / 32,768		92.512	106.968	101.865	94.935		
25	76,000 / 65,536		134.919	161.777	159.405	148.456		
1	1,900,000 / 1,048,576		2760	2779	2890	2696		
0.1	19,000,000 / 16,777,216		39754	39909	41804	39170		

Table 16: Real-time Event Minimum Duration for 100% probability of Trigger (cont.)

Characteristic	Description					
100	8,000	240 / 256	0.611	1.041	0.648	0.905
	1,000	1,900 / 512	2.703	3.207	2.974	2.929
	300	6,334 / 1,024	7.816	8.884	8.286	7.989
	100	19,000 / 4,096	24.838	29.005	26.615	25.888
	30	63,334 / 16,384	88.503	99.438	95.286	94.922
	25	76,000 / 16,384	101.230	112.169	108.048	107.388
	1	1,900,000 / 524,288	2670	2780	2980	2461
	0.1	19,000,000 / 4,194,304	25641	26434	28128	24989
50	4,000	480 / 256	0.850	1.227	0.888	1.181
	1,000	1,894 / 256	2.476	2.970	2.575	2.910
	300	6,334 / 512	7.835	9.017	8.345	8.232
	100	19,000 / 2,048	24.559	29.195	26.484	25.697
	30	63,334 / 8,192	85.654	96.715	93.143	92.642
	25	76,000 / 8,192	98.364	109.275	105.853	105.263
	1	1,900,000 / 262,144	2730	2778	2991	2322
	0.1	19,000,000 / 2,097,152	23430	24048	25055	22247

Table 17: Real-time transforms per second

Characteristic	Description					
	Span (MHz)	RBW (kHz)	DPX Spectrum	DPXogram	Freq mask trigger	Density trigger
Real-time transforms per second, typical	Transforms per second					
	800	50000	2,627,562	1,241,584	2,365,733	1,243,943
		20000	2,376,594	1,174,142	2,094,919	1,196,807
		10000	2,018,280	1,081,222	1,731,537	1,140,029
		1000	906,043	460,681	638,292	710,374
		300	181,750	110,150	158,214	176,353
		100	37,417	24,338	29,850	36,480
		30	14,701	9,700	13,023	14,995
		25	7,346	5,183	6,594	7,350
		1	519	517	443	544
		0.12	37	37	34	38
	320	32,000	2,696,885	1,250,776	2,444,144	1,676,513
		20,000	2,616,606	1,229,611	2,366,207	1,709,864
		10,000	2,436,340	1,174,661	2,167,808	1,605,154
		1,000	1,273,703	753,106	1,030,598	1,181,032
		300	354,423	216,078	258,150	301,316
		100	74,336	47,270	54,275	69,560
		30	34,275	22,918	25,954	32,883
		25	16,974	11,658	11,994	14,032
		1	1,161	1,137	1,009	1,255
		0.1	48	47	43	49
	100	8,000	2,699,036	1,248,489	2,448,673	1,556,652
		1,000	1,245,859	765,075	931,228	999,302
		300	674,595	392,013	512,214	625,691
		100	171,305	99,957	131,344	156,065
		30	39,730	27,702	31,299	33,285
		25	39,639	27,655	31,205	33,452
		1	1,297	1,134	925	1,781
		0.1	150	134	109	166
		50	4,000	2,703,955	1,254,739	2,452,569
	1,000		1,717,706	928,828	1,467,931	1,017,554
	300		658,103	372,705	497,315	553,161
	100		178,889	98,097	133,639	161,150
	30		44,806	29,969	33,554	36,719
	25		44,717	30,064	33,501	36,828
	1		1,204	1,137	916	2,369
0.1	225		197	164	307	

Table 18: Sweep speed

Characteristic	Description
Full-span sweep time, typical mean	(RBW: Auto, Span = 26.5 GHz) Preselector Auto: 14.75 sec Preselector Off: 1.93 sec

Table 19: Recording to RAID, nominal

Characteristic	Description																																								
Sampling rate and maximum record length, nominal	<table border="1"> <thead> <tr> <th>Acquisition BW</th> <th>Streaming Sample Rate (For I and Q)</th> <th>Maximum record length Opt B</th> <th>Maximum record length Opt C</th> </tr> </thead> <tbody> <tr> <td>>320 to 800 MHz</td> <td>1000 MS/s</td> <td>25 min</td> <td>165 min</td> </tr> <tr> <td>>320 to 800 MHz</td> <td>1000 MS/s, unpacked</td> <td>20 min</td> <td>120 min</td> </tr> <tr> <td>>160 to 320 MHz</td> <td>500 MS/s</td> <td>40 min</td> <td>4 hr</td> </tr> <tr> <td>>50 to 160 MHz</td> <td>250 MS/s</td> <td>80 min</td> <td>8 hr</td> </tr> <tr> <td>>50 to 100 MHz</td> <td>150 MS/s</td> <td>130 min</td> <td>13 hr</td> </tr> <tr> <td>>40 to 50 MHz</td> <td>75 MS/s</td> <td>265 min</td> <td>26 hr</td> </tr> <tr> <td>>20 to 40 MHz</td> <td>62.5 MS/s</td> <td>320 min</td> <td>32 hr</td> </tr> <tr> <td>>10 to 20 MHz</td> <td>31.25 MS/s</td> <td>10 hr</td> <td>64 hr</td> </tr> <tr> <td>≤10 MHz</td> <td>15.625 MS/s</td> <td>20 hr</td> <td>128 hr</td> </tr> </tbody> </table>	Acquisition BW	Streaming Sample Rate (For I and Q)	Maximum record length Opt B	Maximum record length Opt C	>320 to 800 MHz	1000 MS/s	25 min	165 min	>320 to 800 MHz	1000 MS/s, unpacked	20 min	120 min	>160 to 320 MHz	500 MS/s	40 min	4 hr	>50 to 160 MHz	250 MS/s	80 min	8 hr	>50 to 100 MHz	150 MS/s	130 min	13 hr	>40 to 50 MHz	75 MS/s	265 min	26 hr	>20 to 40 MHz	62.5 MS/s	320 min	32 hr	>10 to 20 MHz	31.25 MS/s	10 hr	64 hr	≤10 MHz	15.625 MS/s	20 hr	128 hr
	Acquisition BW	Streaming Sample Rate (For I and Q)	Maximum record length Opt B	Maximum record length Opt C																																					
	>320 to 800 MHz	1000 MS/s	25 min	165 min																																					
	>320 to 800 MHz	1000 MS/s, unpacked	20 min	120 min																																					
	>160 to 320 MHz	500 MS/s	40 min	4 hr																																					
	>50 to 160 MHz	250 MS/s	80 min	8 hr																																					
	>50 to 100 MHz	150 MS/s	130 min	13 hr																																					
	>40 to 50 MHz	75 MS/s	265 min	26 hr																																					
	>20 to 40 MHz	62.5 MS/s	320 min	32 hr																																					
>10 to 20 MHz	31.25 MS/s	10 hr	64 hr																																						
≤10 MHz	15.625 MS/s	20 hr	128 hr																																						
	<p>Default signal bandwidth is determined by the maximum bandwidth of each analysis window. Specifying a streaming bandwidth overrides the default and will stop those analyses that require greater bandwidth than specified.</p> <p>1000 GSa/sec samples are normally stored as packed 12-bit samples and must be unpacked to process. Use “unpack.exe” or other software to unpack to 16-bit samples (with 12 significant bits). The user can select to store unpacked samples. In that case, the maximum record lengths will be reduced as shown above.</p>																																								
Disk size and lifetime, 800 MHz bandwidth	<table border="1"> <thead> <tr> <th>RAID option</th> <th>Total time of all records</th> <th>Expected lifetime of disk</th> </tr> </thead> <tbody> <tr> <td>Option B at 1000 MS/s</td> <td>55 min</td> <td>290 hr</td> </tr> <tr> <td>Option B at 1000 MS/s, stored unpacked</td> <td>40 min</td> <td>226 hr</td> </tr> <tr> <td>Option C at 1000 MS/s</td> <td>165 min</td> <td>900 hr</td> </tr> <tr> <td>Option C at 1000 MS/s, stored unpacked</td> <td>120 min</td> <td>680 hr</td> </tr> </tbody> </table>	RAID option	Total time of all records	Expected lifetime of disk	Option B at 1000 MS/s	55 min	290 hr	Option B at 1000 MS/s, stored unpacked	40 min	226 hr	Option C at 1000 MS/s	165 min	900 hr	Option C at 1000 MS/s, stored unpacked	120 min	680 hr																									
	RAID option	Total time of all records	Expected lifetime of disk																																						
	Option B at 1000 MS/s	55 min	290 hr																																						
	Option B at 1000 MS/s, stored unpacked	40 min	226 hr																																						
	Option C at 1000 MS/s	165 min	900 hr																																						
Option C at 1000 MS/s, stored unpacked	120 min	680 hr																																							
	<p>Values scale inversely with Streaming Sample Rate for unpacked samples. See above “Sampling rate and maximum record length, nominal” for sample rate at a specific bandwidth. Eg, at 500 MS/s, expected lifetime is 452 hours. Expected lifetime indicates hours of recording time, not chronological age. Expected lifetime is limited by the maximum number of writes of the SSDs in the RAID system. The RAID controller spreads the writes evenly across all bytes to maximize the system’s lifetime.</p>																																								
Unpacked data	<p>At >320 to 800 MHz acquisition bandwidth, data can be packed in 12-bit samples. This is done to reduce the data transfer rate requirement and to guarantee gap-free recordings. At 320 MHz acquisition bandwidth and below, packing is not necessary and data is always stored as 16-bit samples.</p>																																								

Table 20: GPS location and timing

Characteristic	Description
Format, nominal	GPS (L1: 1575.42 MHz)
GPS antenna power, nominal	5 V, 60 mA max
GPS active antenna power auto-detect threshold, nominal	7.9 mA, max
Maximum RF power at GPS input, nominal	+3 dBm
Horizontal position accuracy, nominal	2.5 m CEP 3.5 m SEP (Test conditions: 24 hours static, -130 dBm received signal strength.)
GPS timestamp accuracy to UTC, typical	±100 ns

Table 21: Pulse measurements, typical

Characteristic	Description	
	40 MHz bandwidth	320 and 800 MHz bandwidth
Minimum Pulse Width for detection, typical	150 ns	50 ns
Average ON Power (18 °C to 28 °C), typical mean	±0.4 dB + absolute Amplitude Accuracy	
	For pulse widths ≥300 ns, and signal levels above 70 dB below reference level	For pulse widths ≥150 ns, duty cycles of .5 to .001, and S/N ratio ≥30 dB
Duty Factor, typical	±0.2% of reading	
	For pulse widths ≥450 ns, duty cycles of 0.5 to 0.001, and S/N ratio ≥ 30 dB	For pulse widths ≥150 ns, duty cycles of 0.5 to 0.001, and S/N ratio ≥ 30 dB
Average Transmitted Power, typical mean	±0.4 dB + absolute Amplitude Accuracy	
	For pulse widths ≥300 ns, duty cycles of 0.5 to 0.001, and S/N ratio ≥ 30 dB	For pulse widths ≥100 ns, duty cycles of 0.5 to 0.001, and S/N ratio ≥ 30 dB
Peak Pulse Power, typical mean	±0.4 dB + absolute Amplitude Accuracy	
	For pulse widths ≥300 ns, duty cycles of 0.5 to 0.001, and S/N ratio ≥ 30 dB	For pulse widths ≥100 ns, duty cycles of 0.5 to 0.001, and S/N ratio ≥ 30 dB
Pulse Width, typical	±0.25% of reading	
	For pulse widths ≥450 ns, duty cycles of 0.5 to 0.001, and S/N ratio ≥ 30 dB	For pulse widths ≥150 ns, duty cycles of 0.5 to 0.001, and signal levels >50 dB below reference Level
System Rise time, typical	<12 ns (85, 125 MHz BW) <7 ns (160 MHz BW)	<40 ns (25 MHz BW) <25 ns (40 MHz BW)

Table 21: Pulse measurements, typical (cont.)

Characteristic	Description		
Pulse-to-Pulse carrier phase, NON-Chirped Pulse, typical mean			
		40 MHz BW ¹	
		320 and 800 MHz BW ²	
	2 GHz	$\pm 0.4^\circ$	$\pm 0.5^\circ$
10 GHz	$\pm 0.4^\circ$	$\pm 0.5^\circ$	
20 GHz	$\pm 0.4^\circ$	$\pm 0.5^\circ$	
Pulse-to-Pulse Delta Frequency, NON-Chirped Pulse, typical mean			
		40 MHz BW ¹	320 MHz BW ³
	2 GHz	± 1 kHz	± 20 kHz
	10 GHz	± 1 kHz	± 20 kHz
	20 GHz	± 5 kHz	± 25 kHz
		800 MHz BW ³	
	2 GHz	± 60 kHz	
	10 GHz	± 60 kHz	
	20 GHz	± 75 kHz	

Table 21: Pulse measurements, typical (cont.)

Characteristic	Description			
Pulse-to-Pulse carrier phase, Linear-Chirped Pulse, typical mean		40 MHz BW ⁴	320 MHz BW ⁵	
	2 GHz	±0.3°	±0.5°	
	10 GHz	±0.3°	±0.5°	
	20 GHz	±0.5°	±0.5°	
		800 MHz BW ⁵		
	2 GHz	±0.75°		
	10 GHz	±0.75°		
	20 GHz	±0.75°		
	Pulse-to-Pulse carrier Frequency, NON-Chirped Pulse, typical mean		40 MHz BW ¹	320 MHz BW ³
		2 GHz	±40 kHz	±400 kHz
		10 GHz	±40 kHz	±400 kHz
		20 GHz	±40 kHz	±400 kHz
			800 MHz BW ³	
		2 GHz	±800 kHz	
		10 GHz	±800 kHz	
20 GHz		±800 kHz		

Table 21: Pulse measurements, typical (cont.)

Characteristic	Description			
Pulse-to-Pulse carrier Frequency, Linear-Chirped Pulse, typical mean		40 MHz BW ⁴	320 MHz BW ⁵	
	2 GHz	±25 kHz	±400 kHz	
	10 GHz	±25 kHz	±400 kHz	
	20 GHz	±25 kHz	±400 kHz	
		800 MHz BW ⁵		
	2 GHz	±800 kHz		
	10 GHz	±800 kHz		
	20 GHz	±800 kHz		
	Pulse Frequency Linearity (Absolute Frequency Error RMS), typical mean		40 MHz BW ⁶	320 MHz ⁷
		2 GHz	±10 kHz	±100 kHz
		10 GHz	±10 kHz	±100 kHz
		20 GHz	±10 kHz	±100 kHz
		800 MHz BW ⁷		
2 GHz		±200 kHz		
10 GHz		±200 kHz		
20 GHz		±200 kHz		

Table 21: Pulse measurements, typical (cont.)

Characteristic	Description		
Chirp Frequency Linearity (Absolute Frequency Error RMS), typical mean			
		40 MHz BW ⁸	320 MHz BW ⁹
	2 GHz	±10 kHz	±150 kHz
	10 GHz	±10 kHz	±150 kHz
	20 GHz	±10 kHz	±150 kHz
		800 MHz BW ⁹	
	2 GHz	±300 kHz	
	10 GHz	±300 kHz	
	20 GHz	±500 kHz	

- 1 For conditions of:
 CW (non-chirped) pulses
 Frequency Estimation = Manual
 Pulse ON power ≥ -20 dBm
 Signal peak at Ref Lvl.
 Atten = 0 dB
 Pulse width = 1 μs
 Duty cycle = 25%
 $t_{\text{meas}} - t_{\text{reference}} \leq 10 \text{ ms}$
 Measurement time position excludes the beginning and ending of the pulse extending for a time = (10/measurement Bandwidth) as measured from the 50% point of the Tr or Tf.
- 2 For conditions of:
 CW (non-chirped) pulses
 Frequency Estimation = Manual
 Pulse ON power ≥ -20 dBm
 Signal peak at Ref Lvl.
 Atten = 0 dB
 Pulse width for 320 MHz = 125 ns
 Pulse width for 800 MHz = 50 ns
 Duty cycle = 25%
 $t_{\text{meas}} - t_{\text{reference}} \leq 10 \text{ ms}$
 Measurement time position excludes the beginning and ending of the pulse extending for a time = (10/measurement Bandwidth) as measured from the 50% point of the Tr or Tf.
- 3 For conditions of:
 CW (non-chirped) pulses
 Frequency Estimation = Manual
 Pulse ON power ≥ -20 dBm
 Signal peak at Ref Lvl.
 Atten = 0 dB
 Pulse width at 320 MHz = 125 ns
 Pulse width at 800 MHz = 50 ns
 Duty cycle = 25%
 $t_{\text{meas}} - t_{\text{reference}} \leq 10 \text{ ms}$
 Measurement time position excludes the beginning and ending of the pulse extending for a time = (10/measurement Bandwidth) as measured from the 50% point of the Tr or Tf.
- 4 For conditions of:

Linear Chirped pulses

For signal type: Linear Chirp, Peak-to-peak Chirp Deviation: $\leq 0.8 \times$ Measurement BW.

Frequency Estimation = Manual

Pulse ON power ≥ -20 dBm

Signal peak at Ref Lvl.

Atten = 0 dB

Pulse width = 1 μ s

Duty cycle = 25%

$t_{\text{meas}} - t_{\text{reference}} \leq 10$ ms

Measurement time position excludes the beginning and ending of the pulse extending for a time = $(10/\text{measurement Bandwidth})$ as measured from the 50% point of the Tr or Tf.

5 For conditions of:

Linear Chirped pulses

For signal type: Linear Chirp, Peak-to-peak Chirp Deviation: $\leq 0.8 \times$ Measurement BW.

Frequency Estimation = Manual

Pulse ON power ≥ -20 dBm

Signal peak at Ref Lvl.

Atten = 0 dB

Pulse width for 320 MHz = 125 ns

Pulse width for 800 MHz = 50 ns

Duty cycle = 25%

$t_{\text{meas}} - t_{\text{reference}} \leq 10$ ms

Measurement time position excludes the beginning and ending of the pulse extending for a time = $(10/\text{measurement Bandwidth})$ as measured from the 50% point of the Tr or Tf.

6 For conditions of:

CW (non-chirped) pulses

Frequency Estimation = Manual

Pulse ON power ≥ -20 dBm

Signal peak at Ref Lvl.

Atten = 0 dB

Pulse width = 1 μ s

Duty cycle = 25%

Absolute Frequency Error determined over center 50% of pulse.

7 For conditions of:

CW (non-chirped) pulses

Frequency Estimation = Manual

Pulse ON power ≥ -20 dBm

Signal peak at Ref Lvl.

Atten = 0 dB

Pulse width for 320 MHz = 125 ns

Pulse width for 800 MHz = 50 ns

Duty cycle = 25%

Absolute Frequency Error determined over center 50% of pulse.

8 For conditions of:

Linear Chirped pulses

For signal type: Linear Chirp, Peak-to-peak Chirp Deviation: $\leq 0.8 \times$ Measurement BW.

Frequency Estimation = Manual

Pulse ON power ≥ -20 dBm

Signal peak at Ref Lvl.

Atten = 0 dB

Pulse width = 1 μ s

Duty cycle = 25%

$t_{\text{meas}} - t_{\text{reference}} \leq 10$ ms

Specifications

Measurement time position excludes the beginning and ending of the pulse extending for a time = $(10/\text{measurement Bandwidth})$ as measured from the 50% point of the Tr or Tf.

Absolute Frequency Error determined over center 50% of pulse.

9 For conditions of:

Linear Chirped pulses

For signal type: Linear Chirp, Peak-to-peak Chirp Deviation: $\leq 0.8 \times \text{Measurement BW}$.

Frequency Estimation = Manual

Pulse ON power ≥ -20 dBm

Signal peak at Ref Lvl.

Atten = 0 dB

Pulse width for 320 MHz = 125 ns

Pulse width for 800 MHz = 50 ns

Duty cycle = 25%

$t_{\text{meas}} - t_{\text{reference}} \leq 10$ ms

Measurement time position excludes the beginning and ending of the pulse extending for a time = $(10/\text{measurement Bandwidth})$ as measured from the 50% point of the Tr or Tf.

Absolute Frequency Error determined over center 50% of pulse.

Table 22: Acquisition

Characteristic	Description				
Real-time Capture Bandwidth, nominal	320 MHz (Standard) 800 MHz (Option B800)				
Sampling Rate and Available Memory time in RTSA/Time/Demod Mode, nominal	Acquisition BW	Sample rate (For I and Q)	Significant bits (I and Q, each)	Record length	Max record time (sec)
	800 MHz	1000 MS/s	12	2 G samples	2.1
	320 MHz	500 MS/s	13	2 G samples	4.2
	160 MHz	250 MS/s	13	2 G samples	8.5
	100 MHz	150 MS/s	13	2 G samples	14.3
	50 MHz	125 MS/s	14	2 G samples	17.1
	40 MHz	62.5 MS/s	14	2 G samples	34.3
	20 MHz	31.25 MS/s	15	2 G samples	68.7
	10 MHz	15.625 MS/s	15	2 G samples	137.4
	5 MHz	7.8125 MS/s	16	1 GSa	137.4
	2 MHz	3.125 MS/s	16	400 MSa	137.4
	1 MHz	1.5625 MS/s	17	200 MSa	137.4
	100 kHz	156.25 kS/s	18	20 MSa	137.4
	10 kHz	15.625 kS/s	19	2 MSa	137.4
	1 kHz	1.5625 kS/s	21	200 kSa	137.4
Minimum Acquisition Length in RTSA/Time/Demod Mode, nominal	64 samples				
Acquisition Length Setting resolution in RTSA/Time/Demod Mode, nominal	1 sample				

Table 23: Amplitude vs. time, nominal

Characteristic	Description
Time Scale (Zero Span)	1 μ s min to 2000 s max
Time Accuracy	\pm 0.5% of total time
Time Resolution	0.1% of total time
Time Linearity	\pm 0.5% of total time (measured at 11 equally-spaced points across the display, including the ends)

Electrical Functional Specifications

Table 24: Measurement function

Characteristic	Description
Frequency Domain Measurement Functions, nominal	Channel Power Adjacent Channel Power Multi-carrier Adjacent Channel Power/Leakage Ratio dBm/Hz Marker dBc/Hz Marker
Time Domain and Statistical Measurement Functions, nominal	RF I/Q vs. Time Power vs. Time Frequency vs. Time Phase vs. Time CCDF Peak-to-Average Ratio
Advanced Measurements Suite (Option SVPH), nominal	Rise Time Fall Time Pulse Width Pulse Peak Power Pulse Average Power Pulse Ripple Pulse Repetition Interval Duty Cycle Pulse-to-Pulse Phase Frequency Error Droop Trend FFT of Trend
General Purpose Digital Modulation Analysis (Option SVM), nominal	Constellation Magnitude Error vs. Time (RMS/Peak) Phase Error vs. Time (RMS/Peak) EVM (RMS/Peak, EVM vs. Time) Waveform Quality (ρ) Frequency Error IQ Origin Offset Gain Imbalance Quadrature Error Symbol Table

Table 24: Measurement function (cont.)

Characteristic	Description
P25 Analysis (Option SV26)	Constellation Modulation Fidelity Frequency Deviation Power Measurements Trigger Measurements
Bluetooth Analysis (Option SV27)	Constellation Frequency Deviation Modulation/Frequency offset/Drift/Output power Inband emissions Tx output spectrum—20dB bandwidth Noncompliance

Table 25: Views by domain

Characteristic	Description
Frequency, nominal	Spectrum (Amplitude vs. Frequency) DPX™ Spectrum Display (Color-Graded Frequency-of-Occurrence) Spectrogram (Spectrums over Time vs. Frequency)
Time and Statistics, nominal	Frequency vs. Time Amplitude vs. Time Phase vs. Time RF I&Q vs. Time Time Overview CCDF Peak-Average-Ratio
Advanced Measurements Suite (Option SVPH), nominal	Pulse Results Table Pulse Trace (Selectable by pulse number) Pulse Statistics (Trend of Pulse Results and FFT of Trend)
General Purpose Digital Modulation Analysis (Option SVM), nominal	Constellation Diagram I/Q vs. Time EVM vs. Time Symbol Table (Binary or Hexadecimal)

Table 25: Views by domain (cont.)

Characteristic	Description
P25 Analysis (Option SV26)	P25 Constellation P25 Summary P25 Eye Diagram P25 Frequency Deviation vs. Time P25 Power vs. Time P25 Symbol Table
Bluetooth Analysis (Option SV27) and Bluetooth 5 Analysis (SV31)	BT CF Offset and Drift BT Eye Diagram BT Constellation BT Frequency Deviation vs. Time BT Summary BT Symbol Table BT 20dB BW (Tx output spectrum, 20dB bandwidth)

Table 26: General Purpose Analog modulation accuracy

Characteristic	Description
AM Demodulation Accuracy, typical	$\pm 2\%$ (0 dBm Input at center, Carrier Frequency 1 GHz, 10 to 60 % Modulation Depth; 1 kHz/5 kHz Input/Modulated frequency; 0 dBm Input Power Level, Reference Level 10 dBm, Atten = Auto)
PM Demodulation Accuracy, typical	$\pm 3^\circ$ (0 dBm Input at center; Carrier Frequency 1 GHz, 400 Hz/1 kHz Input/Modulated Frequency; 0 dBm Input Power Level, Reference Level 10 dBm, Atten = Auto)
FM Demodulation Accuracy, typical	$\pm 1\%$ of Span (0 dBm Input at center; Carrier Frequency 1 GHz, 1 kHz/5 kHz Input/Modulated Frequency, 0 dBm Input Power Level, Reference Level 10 dBm, Atten = Auto)

Table 27: General purpose digital modulation analysis (Option SVM)

Characteristic	Description
Carrier Type, nominal	Continuous, Burst (5 μ s minimum on-time)
Analysis Period, nominal	Up to 164,840 samples
Modulation Format Presets, nominal	$\pi/2$ DBPSK, BPSK, SBPSK, QPSK, DQPSK, $\pi/4$ DQPSK, D8PSK, D16PSK, 8PSK, OQPSK, SOQPSK, CPM, 16QAM, 32QAM, 64QAM, 128QAM, 256QAM, MSK, GFSK, 2FSK, 4FSK, 8FSK, 16FSK, C4FM, 16-APSK, 32-APSK
Measurement Filter, nominal	Root Raised Cosine, Raised Cosine, Gaussian, Rectangular, IS-95 Base EQ, None
Reference Filter, nominal	Gaussian, Raised Cosine, Rectangular, IS-95 baseband, None
Filter Rolloff Factor, nominal	α : 0.001 to 1, 0.001 step
Maximum Symbol Rate, nominal	40 MS/s (Option SVM)
Standard Setup Presets, nominal	None

Table 27: General purpose digital modulation analysis (Option SVM) (cont.)

Characteristic	Description
Measurement Functions, nominal	Constellation, EVM, Symbol Table
Vector Diagram Display Format, nominal	Symbol/Locus Display, Frequency Error Measurement, Origin Offset Measurement
Constellation Diagram Display Format, nominal	Symbol Display, Frequency Error Measurement, Origin Offset Measurement
Eye Diagram Display Format, nominal	None
Error Vector Diagram Display Format, nominal	EVM, Magnitude Error, Phase Error, Waveform Quality (ρ) Measurement, Frequency Error Measurement, Origin Offset Measurement
Symbol Table Display Format, nominal	Binary, Hexadecimal

Table 28: Digital demodulation accuracy (Option SVM)

Characteristic	Description		
QPSK	CF	2 GHz	
Residual EVM, typical mean	Symbol Rate	100 kHz	0.35%
		1 MHz	0.35%
		10 MHz	0.4%
		30 MHz	0.75%
		60 MHz	0.75%
		120 MHz	1.5%
		240 MHz	2.0%
256 QAM	CF	2 GHz	
Residual EVM, typical mean	Symbol Rate	10 MHz	0.4%
		30 MHz	0.6%
		60 MHz	0.6%
		120 MHz	1.0%
		240 MHz	1.5%
400 symbols measurement length, 20 Averages, Normalization reference = Max Symbol Magnitude			
OQPSK	CF	2 GHz	
Residual EVM, typical mean	Symbol Rate	100 kHz	0.6%, 200 kHz measurement BW
		1 MHz	0.6%, 2 MHz measurement BW
		10 MHz	1.0%, 20 MHz measurement BW
Reference Filter: Raised Cosine. Measurement Filter: Root Raised Cosine. Filter Parameter: Alpha = 0.3			

Table 28: Digital demodulation accuracy (Option SVM) (cont.)

Characteristic			Description
S-OQPSK (MIL) Residual EVM, typical mean	CF		250 MHz
	Symbol Rate	4 kHz	0.3%, 64 kHz measurement bandwidth
	Reference Filter: MIL STD, Measurement Filter: None		
S-OQPSK (MIL) Residual EVM, typical mean	CF		2 GHz
	Symbol Rate	20 kHz	0.5%, 320 kHz measurement bandwidth
		100 kHz	0.5%, 1.6 MHz measurement bandwidth
		1 MHz	0.5%, 16 MHz measurement bandwidth
Reference Filter: MIL STD, Measurement Filter: None			
S-OQPSK (ARTM) Residual EVM, typical mean	CF		250 MHz
	Symbol Rate	4 kHz	0.3%, 64 kHz measurement bandwidth
	Reference Filter: ARTM STD, Measurement Filter: None		
S-OQPSK (ARTM) Residual EVM, typical mean	CF		2 GHz
	Symbol Rate	20 kHz	0.5%, 320 kHz measurement bandwidth
		100 kHz	0.5%, 1.6 MHz measurement bandwidth
		1 MHz	0.5%, 16 MHz measurement bandwidth
Reference Filter: ARTM STD, Measurement Filter: None			
S-BPSK (MIL) Residual EVM, typical mean	CF		250 MHz
	Symbol Rate	4 kHz	0.3%, 64 kHz measurement bandwidth
	Reference Filter: MIL STD, Measurement Filter: None		
S-BPSK (MIL) Residual EVM, typical mean	CF		2 GHz
	Symbol Rate	20 kHz	0.5%, 320 kHz measurement bandwidth
		100 kHz	0.5%, 1.6 MHz measurement bandwidth
		1 MHz	0.5%, 16 MHz measurement bandwidth
Reference Filter: MIL STD, Measurement Filter: None			
CPM (MIL) Residual EVM, typical mean	CF		250 MHz
	Symbol Rate	4 kHz	0.3%, 64 kHz measurement bandwidth
	Reference Filter: MIL STD, Measurement Filter: None		
CPM (MIL) Residual EVM, typical mean	CF		2 GHz
	Symbol Rate	20 kHz	0.5%, 320kHz measurement bandwidth
		100 kHz	0.5%, 1.6 MHz measurement bandwidth
		1 MHz	0.5%, 16 MHz measurement bandwidth
Reference Filter: MIL STD, Measurement Filter: None			
2/4/8/16 FSK Residual RMS FSK Error, typical mean	CF		2 GHz
	Symbol Rate	10 kHz	0.5 % (2/4FSK), 10 kHz frequency deviation 0.4 % (/8/16FSK), 10 kHz frequency deviation
	Reference Filter: None, Measurement Filter: None		

Table 29: Adaptive equalizer

Characteristic	Description
Type	Linear, decision-directed, feed-forward (FIR) equalizer with coefficient adaptation and adjustable convergence rate
Modulation types supported	BPSK, QPSK, 8PSK, OQPSK, DQPSK, $\pi/2$ -DBPSK, $\pi/4$ -DQPSK, D8PSK, D16PSK, 16/32/64/128/256-QAM, 16/32-APSK
Reference filters for all modulation types except for OQPSK	Raised Cosine, Rectangular, None
Reference filters for OQPSK	Raised Cosine, Half Sine
Filter length	1 - 128 taps
Taps/symbol: Raised Cosine, Half Sine, or No Filter	1, 2, 4, or 8
Taps/symbol: Rectangular Filter	1
Equalizer controls	Off, Train, Hold, Reset

Table 30: OFDM measurement (Option SVO)

Characteristic	Description
OFDM Maximum Residual EVM (RMS) (802.11a/g/j OFDM and 802.16-2004), typical mean	-52 dB at 2.4 GHz -50 dB at 5.8 GHz

Table 31: WLAN 802.11a/b/g/j/p Tx measurement (Option SV23)

Characteristic	Description
OFDM Maximum Residual EVM (RMS) (802.11a/g/j/p OFDM), typical mean	-50 dB at 2.4 GHz -50 dB at 5.8 GHz
802.11b Maximum Residual EVM (RMS), typical mean	1.0% at 2.4 GHz

Table 32: WLAN 802.11n Tx measurement (Option SV24)

Characteristic	Description
OFDM Maximum Residual EVM (RMS) (802.11n OFDM) 40 MHz BW, typical mean	-49 dB at 2.4 GHz -49 dB at 5.8 GHz

Table 33: WLAN 802.11ac Tx measurement (Option SV25H)

Characteristic	Description
OFDM Maximum Residual EVM (RMS) (802.11ac OFDM), typical mean	-50 dB at 40 MHz BW, CF = 5.8 GHz -48 dB at 80 MHz BW, CF = 5.8 GHz -43 dB at 160 MHz BW, CF = 5.8 GHz

Table 34: P25 analysis (Option SV26)

Characteristic	Description
Residual modulation fidelity (CF = 460 MHz, 815 MHz)	
Phase 1 (C4FM), typical mean	≤1.0%
Phase 2 (HCPM), typical mean	≤0.5%
Phase 2 (HDQPSK), typical mean	≤0.25%

Table 35: Bluetooth® analysis (Option SV27)

Characteristic	Description
Supported standards	Bluetooth® 4.1 Basic Rate (BR) (power classes 1 to 3) Bluetooth® 4.1 Low Energy (LE) Packet types: DH1, DH3, DH5 (BR), Reference (LE)
Output power (BR and LE)	
Average and peak power in line with Bluetooth® RF test specifications RF TS 4.1.1, and BT LE RF PHY 4.1.1.	
Supported measurements	Average power, peak power
Level uncertainty	Refer to (See Table 9 on page 6.)
Measurement range	Signal level >-70 dBm
Basic Rate modulation characteristics (center frequency = 2400 MHz to 2500 MHz)	
Supported measurements	$\Delta F1_{avg}$, $\Delta F2_{avg}$, $\Delta F2_{avg} / \Delta F1_{avg}$, $\Delta F2_{max\%} \geq 115$ kHz
Deviation range	±280 kHz
Deviation uncertainty	<2 kHz + RSA frequency uncertainty (At nominal power level of 0 dBm)
Measurement resolution	10 Hz
Measurement range	Nominal channel frequency ±100 kHz
RF signal power range	>-70 dBm
Low Energy modulation characteristics (center frequency = 2400 MHz to 2500 MHz)	
Supported measurements	$\Delta F1_{avg}$, $\Delta F2_{avg}$, $\Delta F2_{avg} / \Delta F1_{avg}$, $\Delta F2_{max\%} \geq 185$ kHz
Deviation range	±280 kHz
Deviation uncertainty	<3 kHz + RSA frequency uncertainty (At nominal power level of 0 dBm)
Measurement resolution	10 Hz
Measurement range	Nominal channel frequency ±100 kHz
RF signal power range	>-70 dBm
Initial carrier frequency tolerance (ICFT)	
Measurement uncertainty	<1 kHz + RSA frequency uncertainty (At nominal power level of 0 dBm)
Measurement resolution	10 Hz
Measurement range	Nominal channel frequency ±100 kHz

Table 35: Bluetooth® analysis (Option SV27) (cont.)

Characteristic	Description
RF signal power range	>-70 dBm
Carrier frequency drift	
Supported measurements	Max freq. offset, drift $f_1 - f_0$, max drift $f_n - f_0$, max drift $f_n - f_{n-5}$ (BR and LE 50 μ s)
Measurement uncertainty	<1 kHz + RSA frequency uncertainty (At nominal power level of 0 dBm)
Measurement resolution	10 Hz
Measurement range	Nominal channel frequency \pm 100 kHz
RF signal power range	>-70 dBm
In-band emissions (ACPR) level uncertainty	Refer to (See Table 9 on page 6.)

Table 36: LTE measurement

Characteristic	Description
Channel power measurement accuracy, typical	For 40 MHz bandwidth, refer to (See Table 9.)

Table 37: ACLR measurement

Characteristic	Description
ACLR (3GPP Down Link, 1 DPCH) (2130 MHz), typical mean	-67 dB (Adjacent Channel) -67 dB (First Alternate Channel)
ACLR (LTE), typical mean	-67 dB (Adjacent Channel) -69 dB w/Noise Correction (Adjacent Channel) -69 dB (First Alternate Channel) -72 dB w/Noise Correction (First Alternate Channel)
ACLR (P25 C4FM, HCPM, HDQPSK modulation (not noise corrected)), typical mean	-85 dB (CF = 460 MHz, 815 MHz) (Measured at 25 kHz offset, 6 kHz measurement BW)

Table 38: DPX spectrum processing

Characteristic	Description
DPX Spectrogram trace detection	+Peak, -Peak, Avg (Vrms)
DPX Spectrogram trace length	800 to 10401 points

Table 38: DPX spectrum processing (cont.)

Characteristic	Description	
	Trace points	Number of traces
DPX Spectrogram memory depth	801	921,594
	2,401	307,198
	4,001	184,318
	10,401	70,891
Time resolution per line	5 μ s to 6400 s, user-settable (Minimum time resolution specified at 800 MHz RT BW, 1 MHz RBW, 801 trace points.)	

Table 39: OBW Measurement

Characteristics	Description
OBW Accuracy (2 GHz OFDM Carrier, 10 MHz 99% OBW) (measured in a 20 MHz measurement BW, S/N > 30 dB), typical mean	$\pm 0.35\%$

Table 40: xdB Bandwidth Measurement

Item	Description
xdB Bandwidth, typical mean	$\pm 3\%$ to -18 dB below carrier

Table 41: Frequency Settling Time measurement (Option SVT)

Settled frequency uncertainty, typical mean

Measurement frequency, averages	Bandwidth					
	800 MHz	320 MHz	80 MHz	10 MHz	1 MHz	100 kHz
1 GHz						
Single measurement	NA	1 kHz	100 Hz	10 Hz	5 Hz	1 Hz
100 Averages	NA	200 Hz	25 Hz	5 Hz	0.5 Hz	0.1 Hz
1000 Averages	NA	50 Hz	50 Hz	2 Hz	1 Hz	0.05 Hz
10 GHz						
Single measurement	2 kHz	1 kHz	100 Hz	10 Hz	5 Hz	1 Hz
100 Averages	500 Hz	200 Hz	25 Hz	5 Hz	0.5 Hz	0.1 Hz
1000 Averages	250 Hz	100 Hz	10 Hz	1 Hz	0.25 Hz	0.05 Hz

Table 41: Frequency Settling Time measurement (Option SVT) (cont.)

Settled frequency uncertainty, typical mean

Measurement frequency, averages	Bandwidth					
	800 MHz	320 MHz	80 MHz	10 MHz	1 MHz	100 kHz
20 GHz						
Single measurement	3 kHz	1 kHz	100 Hz	25 Hz	5 Hz	1 Hz
100 Averages	1 kHz	200 Hz	25 Hz	10 Hz	1 Hz	0.5 Hz
1000 Averages	500 Hz	100 Hz	10 Hz	5 Hz	0.5 Hz	0.1 Hz

Reference information: Measured input signal > -20 dBm, Attenuator: Auto

Settled phase uncertainty, typical mean

Measurement frequency, averages	Phase uncertainty (degrees)					
	800 MHz	320 MHz	50 MHz	10 MHz	1 MHz	
1 GHz						
Single measurement	NA	0.50	0.50	0.50	0.50	0.50
100 Averages	NA	0.1	0.05	0.05	0.05	0.05
1000 Averages	NA	0.02	0.01	0.01	0.01	0.01
10 GHz						
Single measurement	0.50	0.50	0.50	0.50	0.50	0.50
100 Averages	0.1	0.1	0.05	0.05	0.05	0.05
1000 Averages	0.05	0.02	0.01	0.01	0.01	0.01
20 GHz						
Single measurement	0.50	0.50	0.50	0.50	0.50	0.50
100 Averages	0.1	0.1	0.05	0.05	0.05	0.05
1000 Averages	0.05	0.02	0.01	0.01	0.01	0.01

Reference information: Measured input signal > -20 dBm, Attenuator: Auto

Table 42: AM/FM/PM measurements

Characteristic	Description	Reference information
Analog demodulation		
Carrier frequency range	16 kHz or $\frac{1}{2} \times$ (Audio Analysis Bandwidth) to maximum input frequency	Distortion and noise performance reduced below 30 MHz CF.
Maximum audio frequency span	10 MHz	
Global Conditions for Audio Measurements	Input Frequency: <2 GHz RBW: Auto Averaging: Off Filters: Off FM Performance: Modulation Index >0.1	
Audio filters		
Low Pass	300 Hz, 3 kHz, 15 kHz, 30 kHz, 80 kHz, 300 kHz, and user-entered up to $0.9 \times$ (audio bandwidth)	
High Pass (Hz)	20, 50, 300, 400, and user-entered up to $0.9 \times$ (audio bandwidth)	
Standard	CCITT, C-Message	
De-emphasis (μ s)	25, 50, 75, 750, and user-entered	
User-defined audio file format	User-supplied .txt or .csv file of amplitude/frequency pairs. Up to 1000 amplitude/frequency pairs supported.	

Table 42: AM/FM/PM measurements (cont.)

Characteristic	Description	Reference information
FM modulation analysis		
FM Measurements	Carrier Power Frequency Error Audio Frequency Deviation (+peak, -peak, pk-pk/2, RMS) SINAD Modulation Distortion S/N Total Harmonic Distortion Total Non-Harmonic Distortion Hum and Noise	
FM carrier power accuracy, typical mean	± 0.85 dB	Carrier frequency: 10 MHz to 2 GHz Input power: -20 to 0 dBm
FM carrier frequency accuracy, typical mean	± 0.5 Hz + (transmitter frequency \times reference frequency error)	Deviation: 1 to 10 kHz
FM deviation accuracy, typical mean	\pm (1% of (rate + deviation) + 50 Hz)	Rate: 1 kHz to 1 MHz
FM rate accuracy, typical mean	± 0.2 Hz	Deviation: 1 to 100 kHz
FM residual THD, typical mean	0.10%	Rate: 1 to 10 kHz Deviation: 5 kHz
FM residual distortion, typical mean	0.7%	Rate: 1 to 10 kHz Deviation: 5 kHz
FM residual SINAD, typical mean	43 dB	Rate: 1 to 10 kHz Deviation: 5 kHz
AM modulation analysis		
AM Measurements	Carrier Power Audio Frequency Modulation Depth (+peak, -peak, pk-pk/2, RMS) SINAD Modulation Distortion S/N Total Harmonic Distortion Total Non-Harmonic Distortion Hum and Noise	
AM carrier power accuracy, typical mean	± 0.85 dB	Carrier frequency: 10 MHz to 2 GHz Input power: -20 to 0 dBm
AM depth accuracy, typical mean	$\pm 0.2\%$ + (0.01 \times measured value)	Rate: 1 kHz to 100 kHz Depth: 10% to 90%

Table 42: AM/FM/PM measurements (cont.)

Characteristic	Description	Reference information
AM rate accuracy, typical mean	±0.2 Hz	Rate: 1 kHz to 1 MHz Depth: 50%
AM residual THD, typical mean	0.16%	Rate: 1 to 10 kHz Depth: 50%
AM residual distortion, typical mean	0.13%	Rate: 1 to 10 kHz Depth: 50%
AM residual SINAD, typical mean	58 dB	Rate: 1 to 10 kHz Depth: 50%
PM modulation analysis		
PM Measurements	Carrier Power, Carrier Frequency Error, Audio Frequency, Deviation (+peak, -peak, pk-pk/2, RMS), SINAD, Modulation Distortion, S/N, Total Harmonic Distortion, Total Non-Harmonic Distortion, Hum and Noise	
PM carrier power accuracy, typical mean	±0.85 dB	Carrier frequency: 10 MHz to 2 GHz Input power: -20 to 0 dBm
PM carrier frequency accuracy, typical mean	±0.2 Hz + (transmitter frequency × reference frequency error)	Deviation: 0.628 radians
PM deviation accuracy, typical mean	±100% × (0.01 + (measured rate / 1 MHz))	Rate: 10 kHz to 20 kHz Deviation: 0.628 to 6 radians
PM rate accuracy, typical mean	±0.2 Hz	Rate: 1 kHz to 10 kHz Deviation: 0.628 radians
PM residual THD, typical mean	0.1%	Rate: 1 kHz to 10 kHz Deviation: 0.628 radians
PM residual distortion, typical mean	1%	Rate: 1 kHz to 10 kHz Deviation: 0.628 radians
PM residual SINAD, typical mean	40 dB	Rate: 1 kHz to 10 kHz Deviation: 0.628 radians

Physical Characteristics

Table 43: Power requirements

Characteristic	Description	
	RSA7100A	CTRL7100A
Max power dissipation (fully loaded) ✓	400 Watts max. Maximum line current is 4.5 Amps at 90 V line. 300 W typical.	500 Watts max. Maximum line current is 5.5 Amps at 90 V line. 400 W typical.
Voltage	100 to 240 V at 50 to 60 Hz	90 to 264 V at 47 to 63 Hz

Table 44: Environmental requirements

Characteristic	Description	
	RSA7100A	CTRL7100A
Clearance for cooling		
Bottom/top	44.45 mm (1.75 in)	6.4 mm (0.25 in)
Both sides	44.45 mm (1.75 in)	6.4 mm (0.25 in)
Rear	76.2 mm (3.0 in) (Ensure no outside fans are blowing into the RSA7100A rear fans.)	76.2 mm (3.0 in)
Front	NA	76.2 mm (3.0 in)
Temperature ✓	Operating: 0 °C to +40 °C Nonoperating: -20 °C to +60 °C	Operating: +10 °C to +35 °C Nonoperating: -20 °C to +60 °C
Relative humidity (noncondensing), typical	Operating: 10% to 90% up to +40 °C	Operating: 40% to 70% up to +35 °C
Altitude ✓	Operating: Up to 2000 m (6561 ft) Nonoperating: Up to 12000 m (39370 ft)	Operating: Up to 3000 m (9842 ft) Nonoperating: Up to 12000 m (39370 ft)

Table 45: Dynamics

Characteristic	Description	
	RSA7100A	CTRL7100A
Random vibration ✓	Operating: 5 to 500 Hz, 0.3 G _{rms} Nonoperating: 5 to 500 Hz, 2.45 G _{rms}	Operating: 5 to 500 Hz, 1.0 G _{rms} Nonoperating: 5 to 500 Hz, 2.28 G _{rms}
Shock ✓	Environmental specifications are met in bench configuration of the instrument. Rackmounts supplied with the instrument are intended for stationary applications where high shock and vibration does not occur.	

Table 45: Dynamics (cont.)

Operating	30 g half-sine, 11 ms duration (RF attenuator may change states during horizontal shock. To reset, change to any other state and then back to desired state.)	15 g half-sine, 11 ms duration
Environmental specifications are met in bench configuration of the instrument. Rackmounts supplied with the instrument are intended for stationary applications where high shock and vibration does not occur.		
Nonoperating	30 g half-sine, 11 ms duration	25 g half-sine, 11 ms duration

Table 46: Physical characteristics (RSA7100A)

Characteristic	Description	
	mm	in
Dimensions		
Width (with feet)	445.5	17.54
Height (with feet)	177.1	6.79
Length	577.9	22.75
Weight (without accessories)	kg	lb
Net, nominal	24.2	53.2

3U rack size.

The rackmount kits that come with the RSA7100A and CTRL7100A are not meant for use in vehicles. They are intended only for racks in a stationary environment such as a laboratory or factory. If vehicle rack mount is desired, a tray plus perimeter clamp should be used instead of the rails.

Table 47: Physical characteristics (CTRL7100A)

Characteristic	Description	
	mm	in
Dimensions		
Width	177.8	7.0
Height	450.9	17.75
Depth	660.4	26
Weight	kg	lb
Net, nominal (with Option C7100-B)	23.8	52.4

Table 48: Status indicators

Characteristic	Description
Power LED	LED, red

Table 49: CTRL7100A PC characteristics

Characteristic	Description
I/O	PCIe 2x USB 3.0 on front panel 2x USB 3.0 on rear panel 2x USB 2.0 on rear panel 17 removable drive bays (one for OS, 16 for RAID) 6 Mini-Display ports 2x 10 Gbit Ethernet
RAID	20 minute option includes 10x 1TB drives. 120 minute option includes 16x 2TB drives.
Internal characteristics	GPU: AMD W9100 Dual Intel Xeon E5-2623 V4 4-core (Broadwell) Clock 2.6 GHz Internal cache 10 MB 64 GB DDR4 2133 RAM 512 GB SSD (removable from front panel) Windows 7 OS Optional RAID controller and front-panel removable drives supports 4 GB/s and up to 32 TB

Safety

For detailed information on Safety, see the *RSA7100A Real-Time Spectrum Analyzer Quick Start User Manual*, Tektronix part number 071-3504-XX.

Certifications and Compliances

For detailed information on Certifications and Compliances, see the *RSA7100A Real-Time Spectrum Analyzer Quick Start User Manual*, Tektronix part number 071-3504-XX.

Performance Verification

NOTE. *The performance verification procedure is not a calibration procedure. The performance verification procedure only verifies that your instrument meets key specifications. For your instrument to be calibrated, it must be returned to a Tektronix service facility.*

Prerequisites

The tests in this section make up an extensive, valid confirmation of performance and functionality when the following requirements are met:

- The cabinet must be installed on the instrument.
- The instrument must have passed the Power On Self Tests (POST).
- The instrument must have been last adjusted at an ambient temperature between +18 °C (+64 °F) and +28 °C (+82 °F), must have been operating for a warm-up period of at least 20 minutes after starting the RSA7100A application, and must be operating at an ambient temperature. (See Table 44.)

Required Equipment

The procedures use external, traceable signal sources to directly check warranted characteristics. (See page 47, *Warranted characteristics tests*.) The following table lists the equipment required for this procedure.

Table 50: Equipment required for Performance Verification

Item number and	Minimum requirements	Example	Purpose
1. Frequency Counter	Frequency Range: 10 MHz; Accuracy: 1×10^{-9}	Agilent 53132A Option 10	Checking reference output frequency accuracy
2. RF Power Meter	—	Agilent E4418B	Adjusting signal generator output level,
3. RF Power Sensor 1	9 kHz to 18 GHz RF Flatness: <3% Calibration factor data uncertainty: <2% (RSS)	Agilent E9304A Option H18	checking reference output power level
4. RF Power Sensor 2	10 MHz to 26.5 GHz RF Flatness	Agilent E4413A, Option H10	—
5. Signal Generator	Frequency Accuracy: $\pm 3 \times 10^{-7}$ Output Frequency: 0 to 40 GHz	Anritsu MG3694B Options 2A, 3A, 4, 15A, 16, 22, SM5821	Checking RF flatness, intermodulation distortion, image suppression, and external reference lock check.

Table 50: Equipment required for Performance Verification (cont.)

Item number and	Minimum requirements	Example	Purpose
6. RF Signal Generator	Output Frequency 10 MHz to 26.5 GHz	Anritsu MG3694B	Checking phase noise and third order intermodulation distortion. Higher (worse) phase noise is acceptable if phase noise is not being checked.
	Phase Noise at Center Frequency = 1 GHz	Options 2A, 3A, 4, 15A, 16, 22, SM5821	
	Offset	SSB Phase Noise (F) dBc/Hz	
	100 Hz	-121	
	1 kHz	-134	
	10 kHz	-140	
7. Precision Attenuator	30 dB		—
8. Power Splitter	—	Agilent 11667B	Adjusting signal generator output level
9. Power Combiner	—	Anritsu 2089-6208-00	Checking intermodulation distortion
10. Low Pass Filters (2)	<3 dB loss DC –3.5 GHz	—	Checking third order intermodulation distortion
	>50 dB rejection 5 GHz to 14 GHz		
11. BNC Cable	50 Ω , 36 in. male to male BNC connectors	—	Signal interconnection
12. 3.5 mm -3.5 mm Cable	50 Ω , 36 in. male to male 3.5 mm connectors	—	Signal interconnection
13. N-SMA Cable	50 Ω , 36 in. male N to male SMA connectors	—	Signal interconnection
14. Termination, Precision 50 Ω	Impedance: 50 Ω 3.5 mm male	—	Signal interconnection
15. 3.5 mm (F) to 3.5 mm (F) coaxial adapter	—	Tektronix part number 131-8508-00	—
16. N-3.5mm cable	50 Ω , 36 in. male N to male 3.5 mm connectors	—	—
17. N-Male to 3.5 mm male adapter	—	—	—

Table 50: Equipment required for Performance Verification (cont.)

Item number and	Minimum requirements	Example	Purpose
18. 3.5 mm attenuator	3 dB (two required)	Midwest Microwave ATT-0550-03-35M-02	Checking third order intermodulation distortion
19. Planar Crown RF Input Connector - 3.5 mm	—	Tektronix part number 131-9062-00	—

NOTE. *You may need more adaptors than come with the instrument.*

NOTE. *Always use the Planar Crown adaptor that comes with the RSA7100A instrument to connect to other equipment. Use a proper adaptor when connecting cables with a different connector type.*

NOTE. *Be sure that any adaptor and cable you use is specified to operate at the frequency range of the test you are performing.*

Preliminary Checks

These steps should be performed before proceeding to the Warranted Characteristics tests.

- Fan Check**
1. Connect the RSA7100A to the CTRL7100A with the PCIe cable that shipped with the instrument.
 2. Connect the CTRL7100A power cord to a power source.
 3. Connect the RSA7100A power cord to a power source.
 4. Turn on the CTRL7100A. The controller will automatically launch the SignalVu-PC application and turn on the RSA7100A.
 5. The fans should turn on at 100%. They will be reduced after the application and instrument completes startup.



CAUTION. *Turn the RSA7100A off immediately if the fans are not operating. Operating the analyzer without fans will damage the instrument.*

Warm-up Make sure the SignalVu-PC application is running and that the RSA7100A has powered on. Allow the instrument to warm up for at least 20 minutes.

NOTE. *The fans will slow down and be quieter when the application is started; this is normal. Fan speed may vary while the application is running, depending on the internal temperature detected by the instrument.*

Diagnostics Run a complete Diagnostics test session:

1. Select **Tools > Diagnostics** from the menu bar.
2. Select the **All Modules, All Tests** checkbox at the top of the list.
3. Click the **RUN** button. The diagnostics tests will take some time to complete, and some of them are interactive:
4. When all diagnostics tests have completed, check that there is a check mark beside each diagnostic name. An X instead of a check mark indicates that the diagnostic had a failure.
5. Click the **Diagnostics Failure** Info tab and verify there is no failure information listed.
6. Click the **Exit Diagnostics** button to exit diagnostics.

Alignment You should align the instrument before proceeding with the Warranted Characteristics tests.

1. Select **Alignments** in the **Tools** menu. The Alignments dialog box will open.
2. Select **Align Now**. The alignment process will take a few minutes.
3. Verify that no alignment failures are reported in the status bar.

Warranted characteristics tests

The following procedures verify the RSA7100A performance is within the warranted specifications.

Frequency Accuracy

Check Reference Output Frequency Accuracy

1. Connect **Ref Out** on the RSA7100A front panel through a 50 Ω precision coaxial cable to the frequency counter input. See the following figure.
2. Connect a precision frequency reference to the frequency counter.

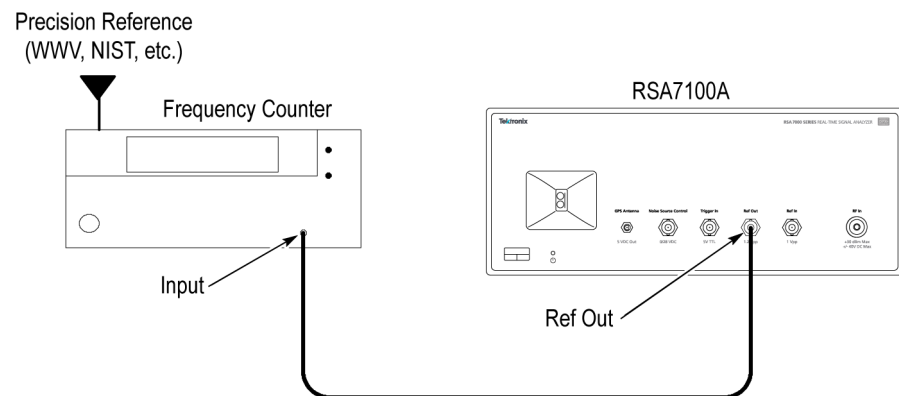

Figure 1: Connections for Reference Frequency Output Accuracy check

3. Set the Frequency counter:

Function	Frequency
Gate time	2 s

4. Check that the frequency counter reads 10 MHz \pm 2 Hz. Enter the frequency in the test record.

**Check Reference Output
Power Level**

1. Set up the power meter and sensor.

NOTE. Store the power sensor correction factors in the power meter, if you have not yet done so.

- a. Connect the power sensor to the Sensor input on the power meter, as shown in the following figure.

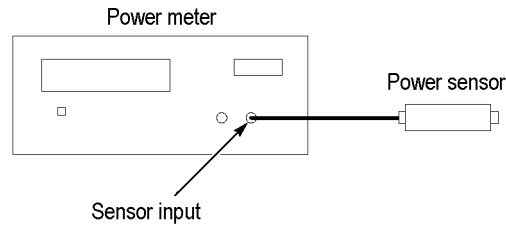

Figure 2: Power meter setup

- b. Press **Zero/Cal**, and then press **ZERO** on the power meter.
- c. Connect the RF input of the power sensor to the power meter power reference output, as shown in the following figure.

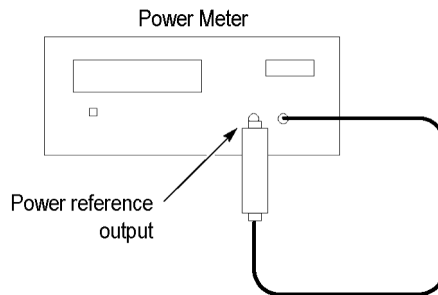

Figure 3: Power meter calibration

- d. Press **CAL** to execute the calibration.
- e. Disconnect the RF input of the power sensor from the power meter reference output.

2. Connect the power sensor RF input to the Ref Out connector on the RSA7100A front panel. (See the following figure.)
3. Press **Frequency/Cal Factor**, and then set **Freq** to 10 MHz.
4. Check that the Ref Out signal is >1 dBm. Enter this level in the test record.

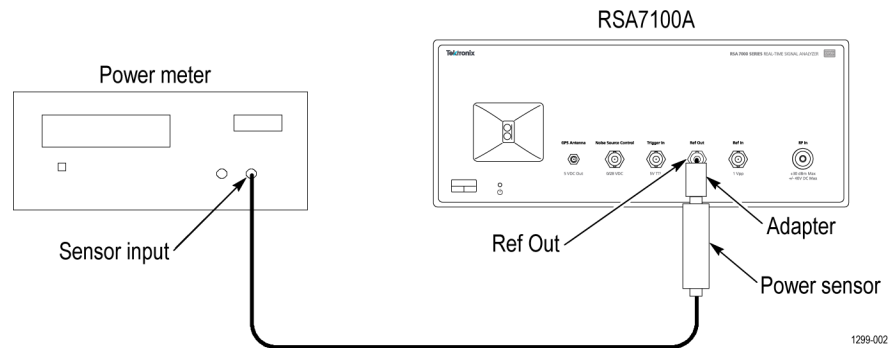

Figure 4: Equipment connections for Ref Out power level check

Amplitude

RF Flatness (Frequency Response) and Absolute Amplitude Accuracy 10 MHz to 26.5 GHz

1. Connect the RF generator, power splitter, power meter, and RSA7100A, as shown in the following figure.

The power splitter outputs should connect directly to the analyzer RF Input and to the power sensor without using cables.

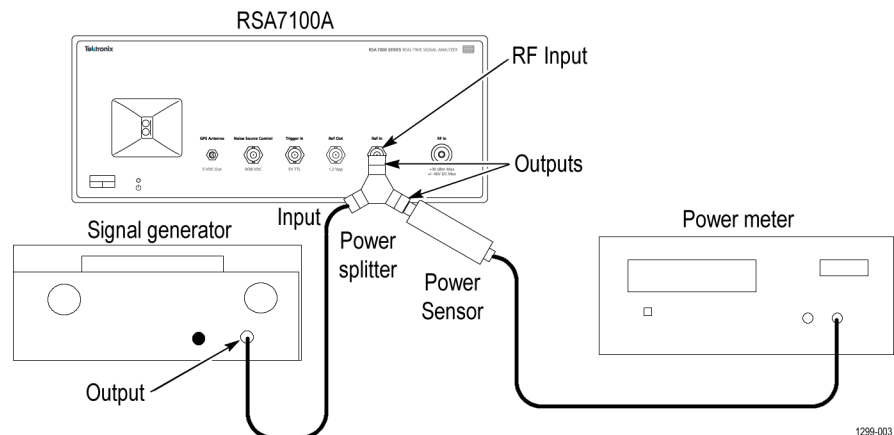

Figure 5: Equipment connections for RF flatness check

2. To record the test readings, you can make a printout of the following table. (See Table 51.)
3. Reset the analyzer to factory defaults: Setup > Preset (Main).
4. Select **Tools > Alignments** and then select **Align Now**.

5. Set the analyzer as follows:

Ref Level	-15 dBm
Setup > Amplitude > Internal Settings > Ref Level	
Internal Attenuator	10 dB (Auto unchecked)
Setup > Amplitude > Internal Settings > Internal Attenuator	
Span	1 MHz
Setup > Settings > Freq & Span > Span	

- Set the RF signal generator for a -14 dBm output amplitude and turn RF On. This will produce about -20 dBm after the -6 dB splitter.
- Set both the RF signal generator output frequency and the analyzer Center Frequency to the frequency in the RF Flatness table. (See Table 51.)
- Select the Markers Peak key to set the Reference Marker (MR) to the carrier peak.
- Adjust the RF signal generator output level for a marker reading of -20 ± 0.5 dBm.
- Record the Power Meter reading and the analyzer marker reading in the following table.
- Calculate the Absolute Amplitude Accuracy (AAA) and record in the table $AAA = \text{Marker Reading} - \text{Power Meter Reading}$.
- Repeat items 7 through 11 for each of the center frequencies shown in the RF Flatness table up to the maximum operating frequency of the device-under-test. (See Table 51.)
- Once the table is complete, determine the RF Flatness for each specified band as follows:

$$RF \text{ Flatness} = \frac{1}{2} (\text{largest AAA in band} - \text{smallest AAA in band})$$

Table 51: RF Flatness (Preamp OFF, attenuator = 10 dB) for Band 100 MHz to 3.6 GHz

Band 100 MHz to 3.6 GHz	Max AAA 0.2 dB	Min AAA -0.3 dB	RF flatness ±0.25 dB
Frequency	Power meter reading	Marker reading	AAA
100 MHz	-20.2	-20.25	-0.05
200 MHz	-20.3	-20.25	0.05
(additional frequencies within the specified band)			
3400 MHz	-20.2	-20.0	0.2
3500 MHz	-19.9	-20.1	-0.3
3600 MHz	-19.8	-19.6	0.2

Table 52: RF Flatness (Preamp OFF, attenuator = 10 dB) for Band 3.6 GHz to 8.5 GHz

Band 3.6 GHz to 8.5 GHz	Max AAA 0.4 dB	Min AAA -0.2 dB	RF flatness ± 0.3 dB
Frequency	Power meter reading	Marker reading	AAA
3600 MHz	-20.2	-20.4	-0.2
3700 MHz	-20.3	-19.9	0.4
(additional frequencies within the specified band)			
8300 MHz	-20.2	-20.0	0.2
8400 MHz	-19.9	-19.7	0.2
8500 MHz	-19.8	-20.2	-0.2

Table 53: RF Flatness (Preamp OFF, attenuator = 10 dB) for Band 8.5 GHz to 14 GHz

Band 8.5 GHz to 14 GHz	Max AAA 0.4 dB	Min AAA -0.2 dB	RF flatness ± 0.3 dB
Frequency	Power meter reading	Marker reading	AAA
8500 MHz	-20.2	-20.4	-0.2
8600 MHz	-20.3	-19.9	0.4
(additional frequencies within the specified band)			

Table 54: RF Flatness (Preamp OFF, attenuator = 10 dB) for Band 14 GHz to 20 GHz

Band 14 GHz to 20 GHz	Max AAA 0.4 dB	Min AAA -0.2 dB	RF flatness ± 0.3 dB
Frequency	Power meter reading	Marker reading	AAA
14000 MHz	-20.2	-20.4	-0.2
14100 MHz	-20.3	-19.9	0.4
(additional frequencies within the specified band)			

Table 55: RF Flatness (Preamp OFF, attenuator = 10 dB) for Band 20 GHz to 26.5 GHz

Band 20 GHz to 26.5 GHz	Max AAA 0.4 dB	Min AAA -0.2 dB	RF flatness ± 0.3 dB
Frequency	Power meter reading	Marker reading	AAA
20000 MHz	-20.2	-20.4	-0.2
20100 MHz	-20.3	-19.9	0.4
(additional frequencies within the specified band)			

Noise and Distortion

Third Order Intermodulation Distortion

1. Set up the RF CW generators, Lowpass filters, Signal Combiner, and analyzer as shown in the following figure.

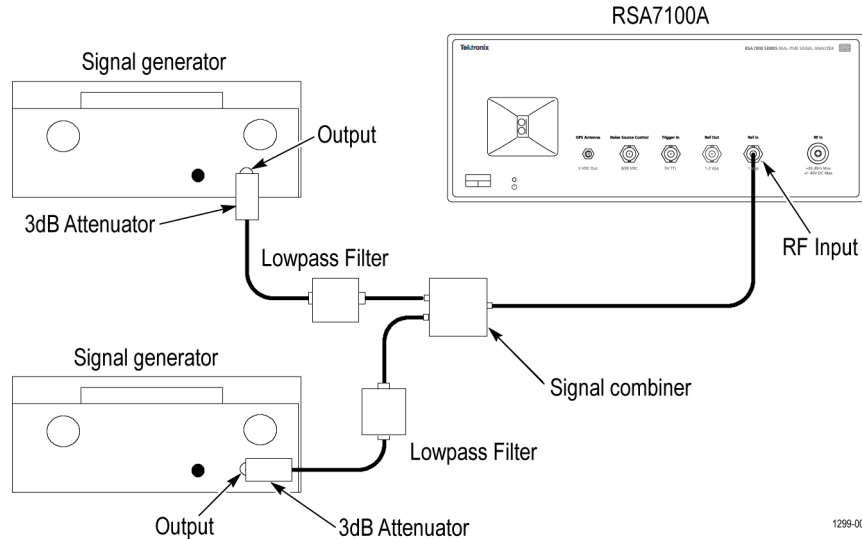

Figure 6: Equipment connections for Third Order Intermodulation Distortion check

2. Reset the analyzer to factory defaults: select **Setup > Preset (Main)**.
3. Select **Tools > Alignments** and select **Align Now**.
4. Set the analyzer as follows:

Ref Level	-10 dBm
Setup > Amplitude > Internal Settings > Ref Level	
Internal Attenuator	0 dB (Auto unchecked)
Setup > Amplitude > Internal Settings > Internal Attenuator	
Span	5 MHz
Setup > Settings > Freq & Span > Span	
RBW	20 kHz
Setup > Settings > BW > RBW	
Function	Avg (VRMS)
Setup > Settings > Traces > Function	
Averaging	25 (Count checked)
(Settings > Traces > Avg (VRMS))	

5. Set each of the RF signal generators to provide a power level of -20 dBm and turn RF On.
 - a. Set the first generator output frequency to 2449.5 MHz, and the second generator output frequency to 2450.5 MHz.
 - b. Set the analyzer Function to Normal (Setup > Settings > Traces > Function > Normal).
 - c. Set the analyzer Center frequency to 2450 MHz. Click the **Markers Peak** button. Adjust the first generator output level for a marker reading of -20.0 dBm. Record this as carrier #1.
 - d. Click the **Markers Next Peak Down** button. Adjust the second generator output level for a marker reading of -20.0 . This is carrier amplitude #2.
6. Restart the analyzer averaging by clicking the **Clear** button. After averaging has completed, click the **Markers Next Peak Down** button and read the marker level. Record this as IM3.
7. Calculate the Third Order Intermodulation Intercept (TOI) using the following equation. Record the results in the test record.

$$TOI = -30 \text{ dBm} - IM3/2$$

DANL – Preamp OFF

1. Terminate the RSA7100A RF Input with a 50Ω terminator.
2. Reset the analyzer to factory defaults: select **Setup > Preset (Main)**.
3. Select **Tools > Alignments** and select **Align Now**.
4. Set the analyzer as follows:

Reference Level	-50 dBm
Setup > Amplitude > Internal Settings > Ref Level	
Internal Attenuator	0 dB (Auto unchecked)
Setup > Amplitude > Internal Settings > Internal Attenuator	
Center Frequency	10 MHz
Setup > Settings > Freq & Span > Center	
Span	100 kHz
Setup > Settings > Freq & Span > span	
RBW	Auto (box checked)
Setup > Settings > BW > RBW	
Detection	Avg (of logs)
Setup > Settings > Traces > Detection	

Function	Avg (of logs)
Setup > Settings > Traces > Function	
Count	1000 (Count box checked)
Setup > Settings > Traces > Function	

5. Set the markers for Noise Mode operation:
 - a. Select **Markers > Define Markers**.
 - b. Select **Add** to add the Reference marker (MR).
 - c. Select **Setup > Settings**, click the **Prefs** tab, and then check the **Marker Noise Mode** checkbox.
6. Set the analyzer to each of the Center Frequencies listed in the following table by entering the value in the Frequency field. After averaging is completed, select the **Markers > Peak** buttons for each Center Frequency setting. As noted below, if the peak is on a spur, not the noise floor, place the marker on the highest point of the noise floor.

Table 56: Frequencies of interest for DANL (Preamp OFF)

Center frequency	Marker noise level	Frequency range
10 MHz		10 MHz - 1.7 GHz
1.7 GHz		
1.71 GHz		1.7 GHz - 2.8 GHz
2.8 GHz		
2.81 GHz		2.8 GHz - 3.6 GHz
3.6 GHz		
3.61 GHz		3.6 GHz - 14 GHz
14 GHz		
14.1 GHz		14 GHz -17 GHz
17 GHz		
17.1 GHz		17 GHz -24 GHz
24 GHz		
24 GHz		24 GHz -26.5 GHz
26.5 GHz		

7. Enter the highest noise level for each of the frequency ranges shown into the test record. (Limits are shown in the test record.)

- DANL – Preamp ON**
1. Reset the RSA7100A to factory defaults: select **Setup > Preset (Main)**.
 2. Select **Tools > Alignments** and select **Align Now**.
 3. Set the analyzer as follows:

Reference Level	-50 dBm
Setup > Amplitude > Internal Settings > Ref Level	
Internal Attenuator	0 dB (Auto unchecked)
Setup > Amplitude > Internal Settings > Internal Attenuator	
Internal Preamp	ON (Internal Preamp box checked)
Setup > Amplitude > Internal Settings > Internal Preamp	
Center Frequency	10 MHz
Setup > Settings > Freq & Span > Center	
Span	100 kHz
Setup > Settings > Freq & Span > span	
RBW	Auto (box checked)
Setup > Settings > BW > RBW	
Detection	Avg (of logs)
Setup > Settings > Traces > Detection	
Function	Avg (of logs)
Setup > Settings > Traces > Function	
Count	100 (Count box checked)
Setup > Settings > Traces > Function	

4. Set the markers for Noise Mode operation:
 - a. Select **Markers > Define Markers**.
 - b. Click the **Add** button to add the Reference marker (MR).
 - c. Select **Setup > Settings** and select the **Prefs** tab. Check the **Marker Noise Mode** checkbox.
5. Set the analyzer to each of the Center Frequencies listed in the following table by entering the value in the Frequency field. After averaging is completed, select the **Markers > Peak** buttons for each Center Frequency setting. As

noted below, if the peak is on a spur, not the noise floor, place the marker on the highest point of the noise floor.

NOTE. *The intent of the DANL test is to measure the average internal noise level of the instrument. The DANL specification does not cover residual spurs. If the specific measurement frequency results in measuring a residual spur that is visible above the noise level, the DANL specification applies not to the spur but to the noise level on either side of the spur. Please refer to the Spurious Response specifications. (See Table 13.) Also, refer to the Spurious Response section of this procedure to determine whether or not a residual spur is within the specification. (See page 56, Spurious Response.)*

Table 57: Frequencies of interest for DANL (Preamp ON)

Center frequency	Marker noise level	Frequency range
10 MHz		10 MHz - 100 MHz
100 MHz		
101 MHz		100 MHz - 1.7 GHz
1.7 GHz		
1.71 GHz		1.7 GHz - 3.6 GHz
3.6 GHz		

6. Enter the highest noise level for each of the frequency ranges shown into the test record. (Limits are shown in the test record.)

Spurious Response

Residual Response

1. Terminate the RSA7100A RF Input with a 50 Ω terminator.
2. Reset the analyzer to factory defaults: select **Setup > Preset (Main)**.
3. Select **Tools > Alignments** and select **Align Now**.
4. Set the analyzer as follows:

Ref Level	-60 dBm
Setup > Amplitude >	
Internal Attenuator	0 dB (Auto unchecked)
Setup > amplitude > Internal Settings > Internal Attenuator	
RBW	1 kHz
Setup > Settings > BW > RBW	

Function	Avg (of logs)
Setup > Settings > Traces > Function	
Count	10 (Count checked)
Setup > Settings > Traces > Function > Count	

- Set the Frequency to each center frequency in the Residual Response Center Frequencies table. Set the span to 50 MHz. Adjust RBW until the noise floor is 10 dB below the residual spur specification. Wait for the averaging to complete, then select **Markers > Peak** and record the marker amplitude in the table.
- Enter the highest of these signal levels into the test record.

Table 58: Residual response center frequencies

Center frequency	Span	Range	Marker amplitude
1.85 GHz	3.5 GHz	100 MHz to 3.6 GHz	
7.3 GHz	7.4 GHz	3.6 GHz to 11 GHz	
11 GHz	14 GHz	11 GHz to 14 GHz	
Option 26 only			
19 GHz	10 GHz	14 GHz to 24 GHz	
25.25 GHz	2.5 GHz	24 GHz to 26.5 GHz	

Image Suppression

- Connect the RF generator capable of at least 26.5 GHz to the RSA7100A RF Input, as shown in the following figure.

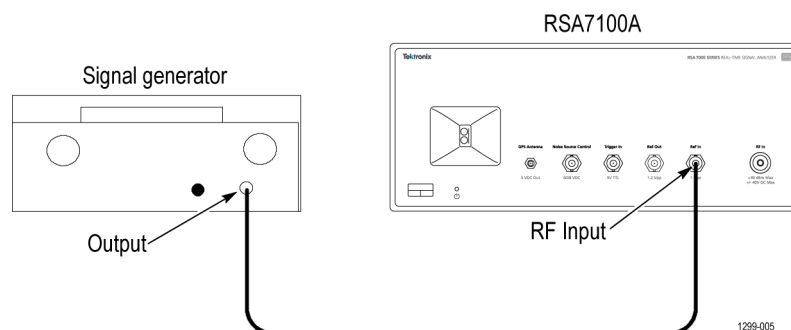

Figure 7: Equipment connections for Image Suppression check

- Reset the analyzer to factory defaults: select **Setup > Preset (Main)**.
- Select **Tools > Alignments** and select **Align Now**.
- Set the analyzer as follows:

Ref Level	0 dBm
Setup > Amplitude > Internal Settings > Ref Level	
Internal Attenuator	10 dB (Auto unchecked)
Setup > Amplitude > Internal Settings > Internal Attenuator	
Span	50 MHz
Setup > Settings > Freq & Span > Span	
RBW	1 kHz (Auto unchecked)
Setup > Settings > BW > RBW	
Function	Avg (of logs)
Setup > Settings > Traces > Function	
Averages	10 (Count checked)
Setup > Settings > Traces > Count	

5. Set the RF generator: Output Level to 0 dBm at the end of the cable and turn RF On. Verify the output level with the power meter, if necessary.
6. For each row of the table below (as appropriate to your instrument model):
 - a. Set the RSA7100A to the Center Frequency shown in the first column.
 - b. Set the RF signal generator frequency to that shown in the first column.
 - c. Set **Function** to **Normal** (Setup > Settings > Traces > Function > Normal).
 - d. Select the **Markers > Peak**.
 - e. Adjust the RF signal generator amplitude to produce a signal level within 1 dB of the Reference Level. Record this value as the carrier level.
 - f. Set the RF generator output frequency to the Image Frequency shown in the second column.
 - g. Set **Function** to **Avg(VRMS)** (Setup>Settings>Traces>Function).
 - h. After the averaging has completed, select **Markers > Peak** to move the MR marker to the peak signal value.
 - i. Read the marker amplitude, in dBm, at the upper-left on the screen. Subtract the carrier level (step e) from the signal image amplitude (step h), to convert it to dBc.
 - j. Enter this value in the test record.
7. Repeat steps through 6 for each frequency in the following table.

Table 59: Image suppression settings

Center Frequency	RF Generator Output Frequency (Image)
2.0 GHz	11.225 GHz
3.0 GHz	12.225 GHz

Table 59: Image suppression settings (cont.)

Center Frequency	RF Generator Output Frequency (Image)
6 GHz	7.225 GHz
10 GHz	11.225 GHz
14 GHz	15.225 GHz
Option 26 only	
18 GHz	19.225 GHz
22 GHz	12.225 GHz
25 GHz	26.225 GHz

NOTE. The intent of the image spurious test is to measure spurious responses caused by the injection of an external signal that would induce an image product on the display. These images can be the same frequencies as residual spurs. In case of question, slightly change the frequency of the input signal to induce a corresponding change in the displayed frequency of the image spur. Change the input frequency in steps that allow the product to stay within the on-screen frequency span. If the on-screen spur does not move in response to the input signal change, it is not an image and is not covered in the image spurious specification. Some care must be taken in noting the frequency change. The images specified in the specification are 1:1 images and they will move -1:1 with changes in input signal frequency. Never discount the possibility that a spur in question could be coming from the test signal generator. Such spurious responses can also move with changes in signal generator frequency. In case of question, validate the performance of the generator with a different Signal Analyzer and/or filter the signal from the test generator to remove unwanted products.

If the spur seen on screen is a residual, it will still be present with the input to the signal analyzer terminated in 50 ohms. Residual spurs are subject to separate specification limits.

Test record

Print out the following test record pages and use them to record the performance test results for your analyzer.

RSA7100A test record

Model:

Serial Number:

Certificate Number:

Calibration Date:

Technician:

Performance Verification

Frequency Accuracy	Low limit	Test result	High limit
Reference output frequency accuracy	9,999,998 Hz		10,000,002 Hz
Reference output power level	1 dBm		10 dBm

Absolute amplitude accuracy (unless frequency response is specified)	Low limit	Test result	High limit
Attenuator = 10 dB			
10 MHz - 3.6 GHz (Preamp OFF, frequency response)	-0.16 dB		+0.16 dB
10 MHz - 3.6 GHz (Preamp ON, frequency response)	-0.2 dB		+0.2 dB
10 MHz - 3.6 GHz (Preamp OFF)	-0.8 dB		+0.8 dB
100 MHz - 3.6 GHz (Preamp ON)	-1.2 dB		+1.2 dB
3.6 GHz - 8.5 GHz (Preselector OFF)	-0.9 dB		+0.9 dB
3.6 GHz - 8.5 GHz (Preselector ON)	-1.6 dB		+1.6 dB
8.5 GHz - 14 GHz (Preselector OFF)	-1.0 dB		+1.0 dB
8.5 GHz - 14 GHz (Preselector ON)	-1.5 dB		+1.5 dB
14 GHz - 20 GHz (Preselector OFF)	-1.7 dB		+1.7 dB
14 GHz - 20 GHz (Preselector ON)	-2.6 dB		+2.6 dB
20 GHz - 26.5 GHz (Preselector OFF)	-2.0 dB		+2.0 dB
20 GHz - 26.5 GHz (Preselector ON)	-2.8 dB		+2.8 dB

Third Order Intermodulation Distortion (3rd Order Intercept)	Low limit	Test result
3.3 GHz	24 dBm	

Displayed Average Noise Level (DANL)	Test result	High limit
Preamp OFF, normalized to 1 Hz RBW, with log-average detector		
10 MHz - 1.7 GHz		-153 dBm/Hz
1.7 GHz - 2.8 GHz		-150 dBm/Hz
2.8 GHz - 3.6 GHz		-148 dBm/Hz
3.6 GHz - 14 GHz		-152 dBm/Hz
14 GHz - 17 GHz		-145 dBm/Hz
17 GHz - 24 GHz		-150 dBm/Hz
24 GHz - 26.5 GHz		-146 dBm/Hz

Displayed Average Noise Level (DANL)

	Test result	High limit
Preamp ON, normalized to 1 Hz RBW, with log-average detector		
10 MHz – 100 MHz		-163 dBm/Hz
100 MHz – 1.7 GHz		-164 dBm/Hz
1.7 GHz – 3.6 GHz		-162 dBm/Hz

Residual Response

	Test Result	High limit
100 MHz – 3.6 GHz		-99 dBm
3.6 GHz – 11 GHz		-102 dBm
11 GHz – 14 GHz		-86 dBm
14 GHz – 24 GHz (Option 26)		-86 dBm
24 GHz – 26.5 GHz (Option 26)		-84 dBm

Image response

	Test result	High limit
100 MHz to 3.6 GHz		-98 dBc
3.6 GHz to 14 GHz		-81 dBc
14 GHz to 26.5 GHz (Option 26)		-74 dBc