

10BASE-T1S Automotive Ethernet Compliance Test Solution

Option 5-CMAUTOEN10 and 6-CMAUTOEN10 Datasheet

Get more visibility into your 10BASE-T1S designs



Get more visibility into your Automotive Ethernet designs with 10BASE-T1S Automotive Ethernet Compliance Test Solution for the 5 and 6 Series MSO Mixed Signal Oscilloscope. The combination of the oscilloscope, analysis software, and a wide range of available analog probes enable you to perform detailed and accurate amplitude and timing measurements on your designs. The integration of Automotive Ethernet is placing greater demands on technology and is placing even greater demands on comprehensive design validation to ensure interoperability between multiple Electronic Control Units (ECU) and reliability in demanding environments. A complete testing solution enables passing strict compliance tests and provides greater confidence in design margins under real world conditions.

Key features

- **Test time:** Fully automated with a setup wizard to perform compliance testing as per the 10BASE-T1S (IEEE 802.3cg™) standard. Highly optimized and intuitive user interface for quick test configuration and validation of electrical signals. The 5-CMAUTOEN10/6-CMAUTOEN10 software automatically configures equipment per the test requirements which reduces overall test execution time.
- **Test coverage:** The TekExpress Automotive Ethernet solution for 10BASE-T1S is designed to comply with the IEEE 802.3cg™ specification covering transmitter testing.
- **Validation and debug:** Tools such as Advanced Jitter Analysis (DJA) let you identify problems before compliance testing or in the event of a failure.
- **Comprehensive report:** Automated reporting with Pass/Fail status and screen shots of the waveforms.
- **Measurement accuracy:** Tektronix 5/6 Series Mixed Signal Oscilloscopes offer analog bandwidth up to 8 GHz, sample rates up to 25 GS/s and 12-bit analog-to-digital converters (ADC), delivering the performance needed to capture waveforms with high signal fidelity and resolution.
- **Domain measurements:** Time domain and frequency domain measurements (Return Loss and Power Spectral Density) can be made with a single instrument. Tektronix' patented measurement approach in the TekExpress Automotive Ethernet Test Solution enables designers to perform return loss measurements using an oscilloscope, reducing the need for additional test equipment.
- **Performance verification:** The Automotive Ethernet application enables you to easily run tests multiple times. The statistics in the reports display Pass/Fail status for each run to help study device performance over different runs.

Fully automated compliance testing

The Tektronix 5-CMAUTOEN10/6-CMAUTOEN10 Automotive Ethernet (10Base-T1S Short Reach) automated compliance test solution is a fully automated compliance test application for the 10BASE-T1S (IEEE 802.3cg™) standard. Executing all the measurements manually is extremely time-consuming. The TekExpress Automotive Ethernet application provides an automation framework that enables you to execute all the measurements with minimal intervention, only when you need to change connections.

The physical layer compliance tests are defined to ensure interoperability between different designs and hardware vendors. The requirements to perform these tests have been expanded and now cover Automotive Ethernet 10BASE-T1S standards.

The test suite runs on 5/6 Series MSOs, and lets you to take full advantage of the oscilloscope validation and debug capabilities in addition to compliance testing. The Tektronix Automotive Ethernet Solution provides greater confidence in design margins under real world conditions by ensuring that your designs pass the strict 10BASE-T1S compliance tests.

Supported 10BASE-T1S tests

Test Name	Test Mode	Instrument
Transmitter Output Droop	2	350 MHz Oscilloscope
Transmitter Timing Jitter	1	
Transmitter Power Spectral Density (PSD)	3	
Transmitter Clock Frequency	1	
Peak Differential Output	1	
MDI Return Loss	Slave Idle Mode	350 MHz Oscilloscope and AFG or Tektronix VNA

The 5-CMAUTOEN10/6-CMAUTOEN10 TekExpress Automotive Ethernet software allows for complete or selective testing of any of the transmitter electrical specifications. Tests are configured by following a step-by-step process. Software navigation follows a logical workflow for quick test setups, configurations, and review of test results. The software sets up the oscilloscope and automates the tests, guiding you to accurate and repeatable results.

Test setup configurations vary greatly in terms of connections to the device under test, probing, test fixtures, calibration, and use of the oscilloscope and signal generator. To help you to correctly set up for a measurement, the Automotive Ethernet software provides setup instructions for each test, with images and reference illustrations, to ensure the correct setup.

Connection diagram for Return Loss Calibration

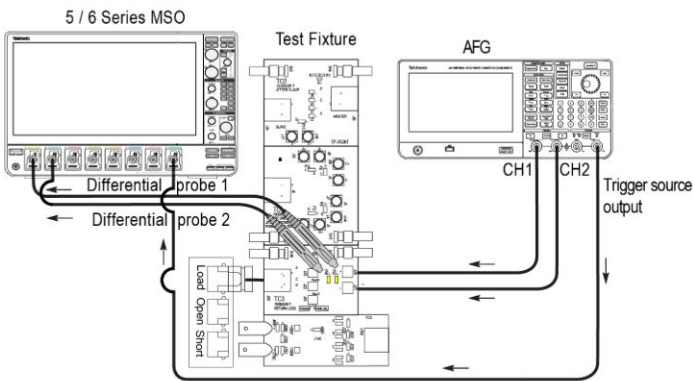

Note: For best results, connect the Oscilloscope, DUT, and test fixture to a common ground.
Return loss

The application generates a comprehensive, date-stamped test report with pass/fail results, waveforms, and data plots.

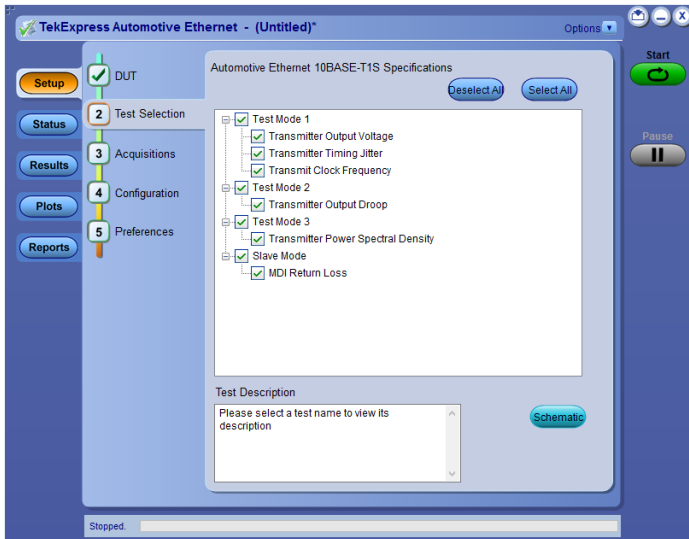

The 5-CMAUTOEN10/6-CMAUTOEN10 TekExpress Automotive Ethernet compliance software requires a Tektronix 5/6 Series MSO with Option 5-WIN/6-WIN or SUP5-WIN/SUP6-WIN (Microsoft Windows 10). Since it operates as a Windows application, the software shares the oscilloscope display. For convenience, we recommend that you add an external monitor to display the compliance software and test reports separately from the oscilloscope screen.

Return loss measurement

The MDI return loss test determines the impedance mismatch between PHY and reference MDI Connector from the differential impedance specification of 100 Ω , which will affect hardware interoperability. Return Loss is a frequency domain measurement and generally requires an additional frequency domain test instrument to run the measurement. Using a patented technique, you can perform an MDI return loss measurement using oscilloscope and function generator. To learn more about return loss measurement using oscilloscope, please refer to Patent No [US007271575B2](https://patents.google.com/patent/US007271575B2).

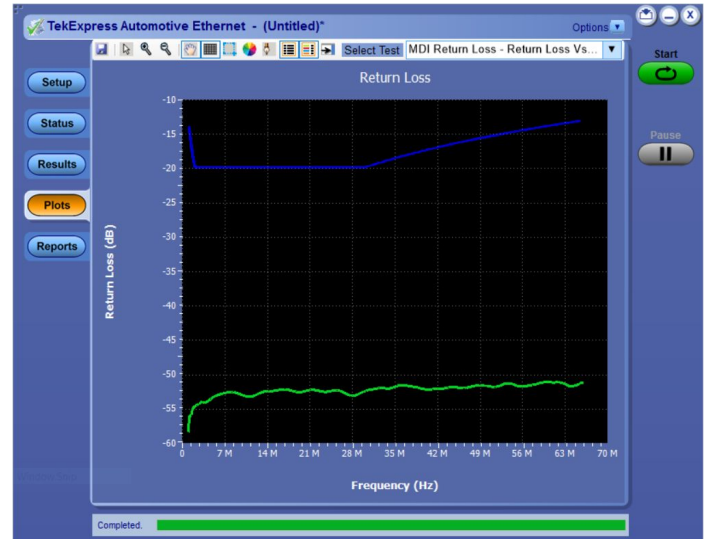

Return loss plot generated using the oscilloscope and AFG

Transmitter clock frequency and jitter measurements

Jitter tests quantify the timing variations of the edges of the signal, using specified test patterns. These jitter measurements include contributions from duty cycle distortion and baseline wander. The jitter peak-to-peak measurement is determined by the minimum and maximum values in the tails of the histogram. The DUT is set to test mode 1.

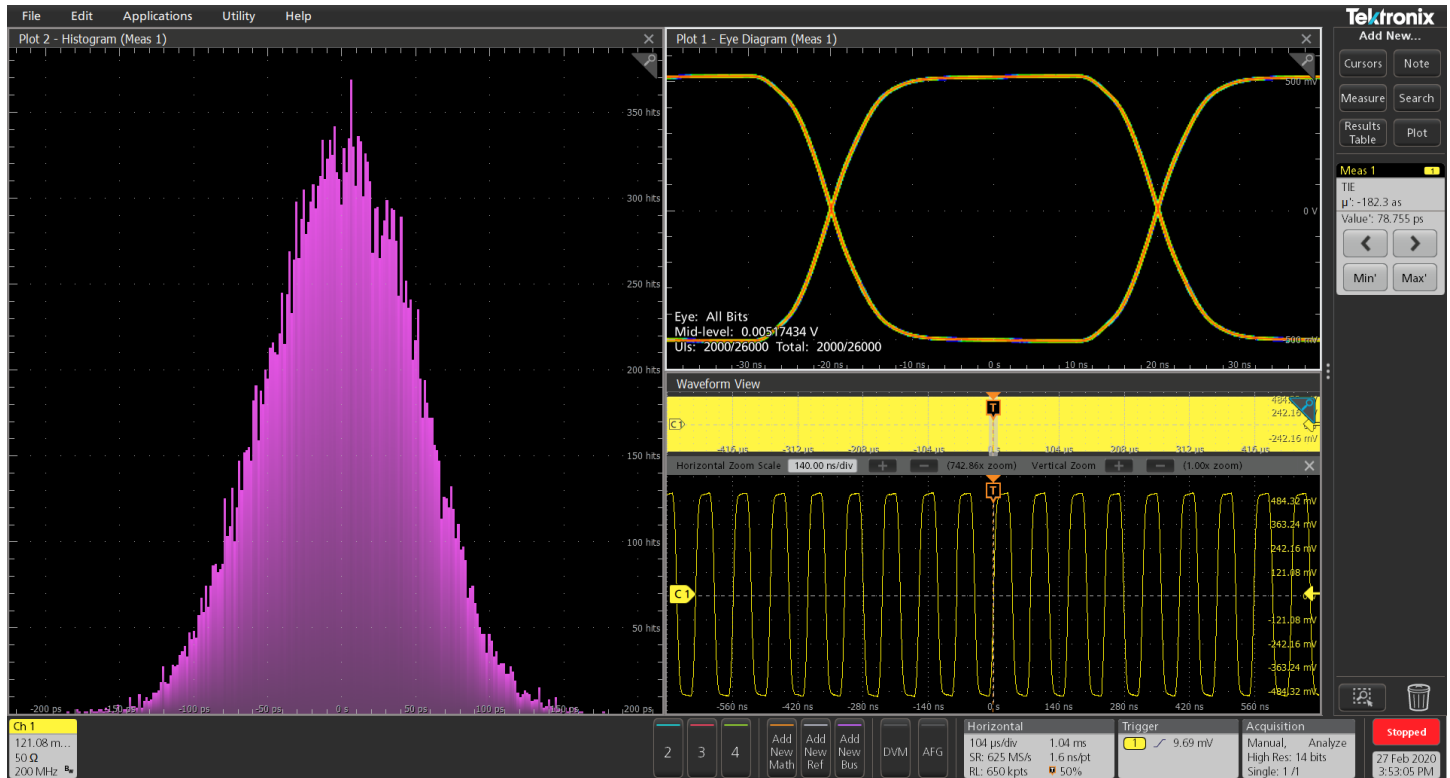

Jitter measurement

Droop measurement

The droop measurements are performed by determining the positive and negative waveform peak voltages. The DUT is set to test mode 2.

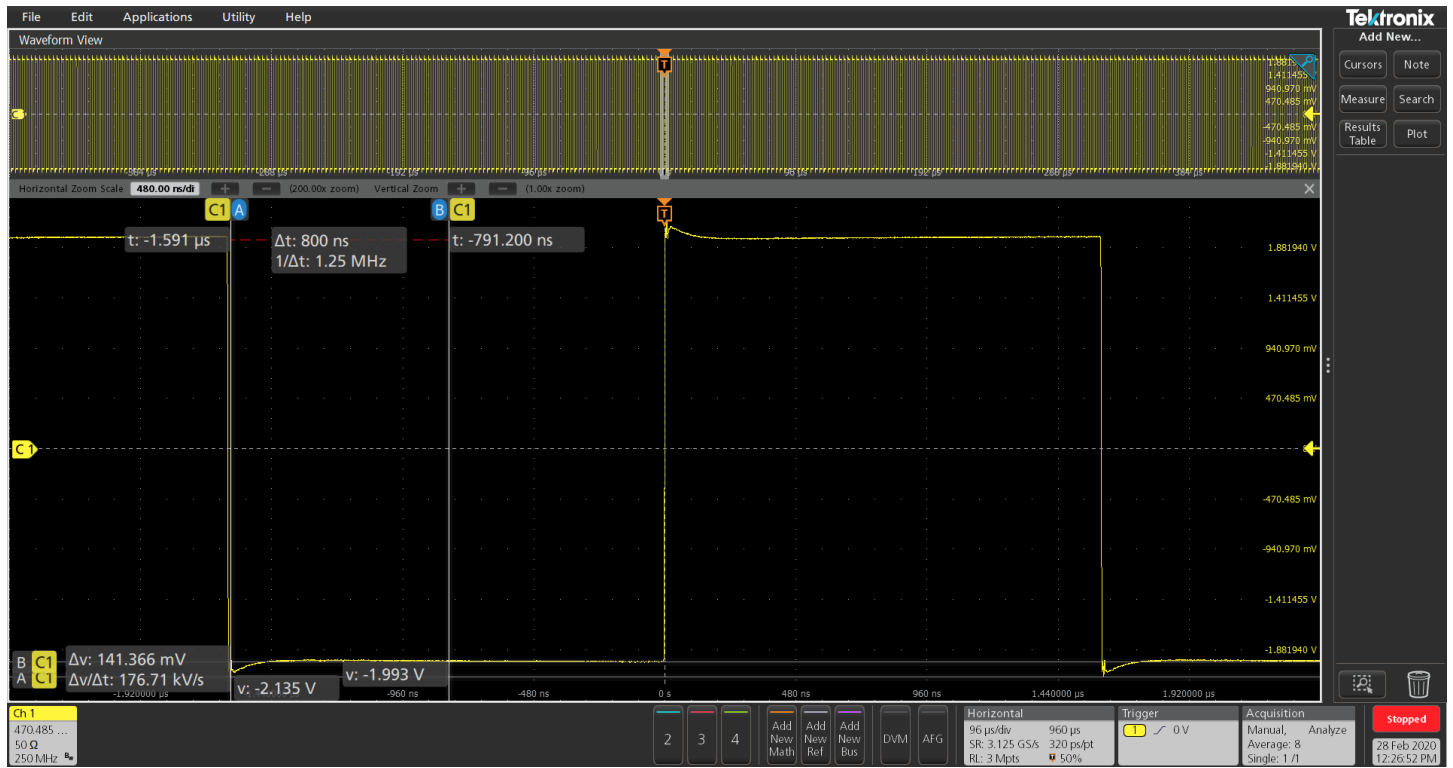

Droop measurement

Power spectral density measurement

Power Spectral Density (PSD) is a frequency domain measurement that is often performed using a spectrum analyzer. The 5/6 Series MSO, with 12-bit analog-to-digital converters (ADC) and outstanding noise performance, provides accuracy similar to a spectrum analyzer. The spectrum of an input signal in test mode is computed using built-in oscilloscope math functions. The post-processing is done on the signal to determine the PSD. The computed PSD is then compared with the upper and lower masks as defined in the specification to arrive at the final result.

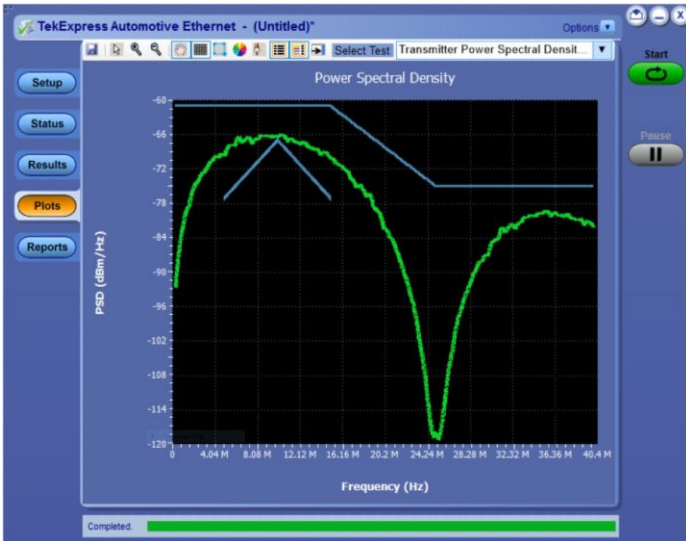

Power spectral density measurement

Limits

The 10BASE-T1S Automotive Ethernet can operate in point-to-point or multi-drop mode. In point-to-point connections, devices operate at 100 ohm impedance but in other cases devices operate at 50 ohm impedance. The IEEE specifies measurement limits for 100 ohm and 50 ohm impedances. The Tektronix 5-CMAUTOEN10/6-CMAUTOEN10 10BASE-T1S Automotive Ethernet compliance software allows you to configure limit depending upon the device configuration. The application can work in compliance mode, where limits are defined per compliance specifications, or in user defined mode, which allows you to edit the limits to perform characterization of the DUT.

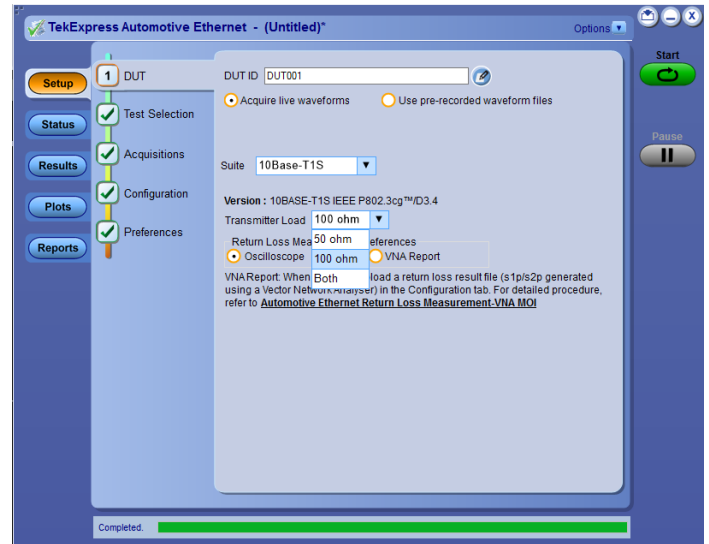

DUT setup

Validation and debug

Validation and debugging are easily accomplished early in the design process and ahead of final compliance testing with the 5/6 Series MSO. The oscilloscopes' standard measurement set, along with the optional DJA (Advanced Jitter and Timing Analysis) software supports several key compliance tests including:

- Clock frequency
- Transmitter amplitude with histogram
- Full characterization of jitter performance including Time Interval Error (TIE)
- Histogram profiles

This type of early testing increases the likelihood of passing compliance tests, while allowing more complete characterization and determination of design margins. Master and slave jitter measurements can be particularly challenging given the tight compliance limits and the need to eliminate any possible sources of random or deterministic jitter.

Pass/fail reports

The 5-CMAUTOEN10/6-CMAUTOEN10 Automotive Ethernet (10Base-T1S Short Reach) automated compliance test application creates compliance test documentation quickly with a summary report in MHL or PDF format. The software automatically generates a report after test execution is complete, and includes Pass/Fail status to help you quickly analyze the test results. The report also includes test configuration details, waveform plots, oscilloscope screen shots, and margin analysis to provide more insights into your design.

Tektronix® TekExpress Automotive Ethernet Transmitter Test Report							
Setup Information							
DUT ID	DUT001	TekExpress Automotive-Ethernet	1.3.0.95				
Date/Time	2020-01-28 12:48:20	Framework Version	4.15.0.2				
Pre-Recorded Mode	False	Scope Model	MS054				
Compliance Mode	True	Firmware Version	1.14.13.6144				
Suite Name	10Base-T1S	Probe1 Model	TDPI500				
Overall Execution Time	0:00:28	Probe1 Serial Number	Q100012				
Overall Test Result	Pass	Probe2 Model	TCA-SMA				
		Probe2 Serial Number	N.A				
DUT COMMENT: General Comment - Automotive Ethernet DUT							
Test Name Summary Table							
Transmitter Power Spectral Density	Informative						
Statistics							
Measurement Details	Run Count	Min	Max	Average	Units	Standard Deviation	
Power Spectral Density 50ohm	1	0	0	0	HITS	0	
Power Level 50ohm	1	6.266	6.266	6.266	dBm	0	
Transmitter Power Spectral Density							
Measurement Details	Test Result	Low Limit	Measured Value	High Limit	Units	Margin	Run#
Power Spectral Density 50ohm	Pass	NA	0	0	HITS	LL: N.A, HL: 0	1
Power Level 50ohm	Informative	NA	6.266	NA	dBm	LL: N.A, HL: N.A	1
COMMENTS: Signal Validation - Pass. Signal Validation passed For run 1: Sample rate: 1.25GS/s, Record length: 2.5M, RBW: 1.0kHz, Start frequency: 0.3MHz, Stop frequency: 40.0MHz, Spectral average value: 2							

Measurement report in MHT format

6 Series MSO oscilloscope

With up to 8 GHz analog bandwidth, 25 GS/s sample rates, lowest noise and highest resolution, the 6 Series MSO oscilloscope has the performance you need to capture waveforms with the best possible signal fidelity.



At the heart of the 6 Series MSO oscilloscope are 12-bit analog-to-digital converters (ADCs) that provide 16 times the vertical resolution of traditional 8-bit ADCs. This resolution, combined with an extremely low-noise front end, allows you capture small signal details even on relatively large signals.

Test fixtures and probing test points

Accurate and repeatable compliance testing requires access to the PHY transmitter output. The recommended approach is to use the Tektronix TF-XGbT Ethernet fixture. These fixtures can support all test setups while providing convenient test points for probing. If there is a provision to probe directly on DUT, user can perform compliance test without fixture.

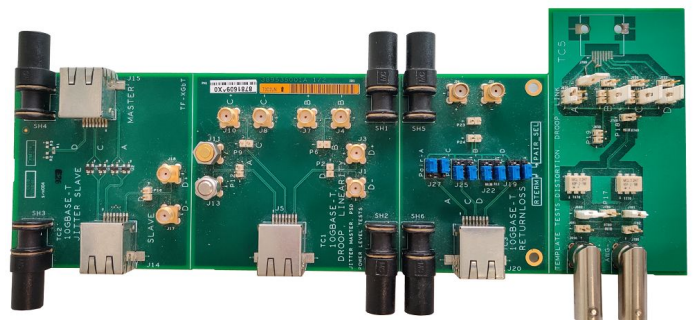

TF-XGbT test fixture

Ordering information

Measurements and required hardware

Measurements	Required hardware
Transmitter Output Droop Transmitter Timing Jitter Transmitter Clock Frequency Differential Output Transmitter Power Spectral Density	5/6 Series MSO with a probe (TDP1500, P6247 or P6248)
Return Loss	5/6 Series MSO AFG31102 2 Nos TDP1500, P6247 or P6248 probes

Required hardware

Product	options
Oscilloscope	5 Series MSO with minimum bandwidth of 350 MHz (option 5-BW-350) or 6 Series MSO with (Option 5-WIN/6-WIN or SUP5-WIN/SUP6-WIN- removable SSD with Microsoft Windows 10 operating system)
Signal generators	Tektronix AFG31102
Probes	TDP1500, P6247 or P6248 (requires use of TPA-BNC adapter)

Required software

Product	Options
Automotive Ethernet (10Base-T1S Short Reach) automated compliance test solution	Option 5-CMAUTOEN10/6-CMAUTOEN10 or SUP5-CMAUTOEN10/SUP6-CMAUTOEN10

Optional software

Product	Options
Advanced Jitter and Eye Analysis	Option 5-DJA/6-DJA or SUP5-DJA/SUP6-DJA
Automotive Ethernet Signal Separation	Option 5-AUTOEN-SS/6-AUTOEN-SS
PAM3 Analysis	Option 5-PAM3 or 6-PAM3
100BASE-T1 Protocol Decode	Option 5-SRAUTOEN1 or 6-SRAUTOEN1
125 M record length	Option 5-RL-125M/6-RL-125M or SUP5-RL-125M/SUP6-RL-125M
CAN, CAN FD, LIN, FlexRay serial bus trigger and decode	Option 5-SRAUTO/6-SRAUTO or SUP5-SRAUTO/SUP6-SRAUTO
SENT Protocol trigger and decoder	Option 5-SRAUTOSEN/6-SRAUTOSEN or SUP5-SRAUTOSEN/SUP6-SRAUTOSEN
I2C, SPI serial bus trigger and decode	Option 5-SREMBD/6-SREMBD or SUP5-SREMBD/SUP6-SREMBD

Recommended accessories

Product	Quantity
External PC monitor	1
TF-XGbT test fixture	1
SMA female to BNC male adapter	2
SMA cables for signal source connections	3 cables of same length
50 ohm SMA M terminator cap	2

Additional accessories for Multidrop test

Product	Quantity
SMA male to SMA female RF coaxial adapter connector three way splitter	2
50 ohm SMA M terminator cap	4
SMA male to SMA male RF coaxial cable adapter	2
SMA female to female adapter	2



Tektronix is registered to ISO 9001 and ISO 14001 by SRI Quality System Registrar.



Product(s) complies with IEEE Standard 488.1-1987, RS-232-C, and with Tektronix Standard Codes and Formats.



Product Area Assessed: The planning, design/development and manufacture of electronic Test and Measurement instruments.

ASEAN / Australasia (65) 6356 3900
Belgium 00800 2255 4835*
Central East Europe and the Baltics +41 52 675 3777
Finland +41 52 675 3777
Hong Kong 400 820 5835
Japan 81 (3) 6714 3086
Middle East, Asia, and North Africa +41 52 675 3777
People's Republic of China 400 820 5835
Republic of Korea +822 6917 5084, 822 6917 5080
Spain 00800 2255 4835*
Taiwan 886 (2) 2656 6688

Austria 00800 2255 4835*
Brazil +55 (11) 3759 7627
Central Europe & Greece +41 52 675 3777
France 00800 2255 4835*
India 000 800 650 1835
Luxembourg +41 52 675 3777
The Netherlands 00800 2255 4835*
Poland +41 52 675 3777
Russia & CIS +7 (495) 6647564
Sweden 00800 2255 4835*
United Kingdom & Ireland 00800 2255 4835*

Balkans, Israel, South Africa and other ISE Countries +41 52 675 3777
Canada 1 800 833 9200
Denmark +45 80 88 1401
Germany 00800 2255 4835*
Italy 00800 2255 4835*
Mexico, Central/South America & Caribbean 52 (55) 56 04 50 90
Norway 800 16098
Portugal 80 08 12370
South Africa +41 52 675 3777
Switzerland 00800 2255 4835*
USA 1 800 833 9200

* European toll-free number. If not accessible, call: +41 52 675 3777

For Further Information. Tektronix maintains a comprehensive, constantly expanding collection of application notes, technical briefs and other resources to help engineers working on the cutting edge of technology. Please visit www.tek.com.

Copyright © Tektronix, Inc. All rights reserved. Tektronix products are covered by U.S. and foreign patents, issued and pending. Information in this publication supersedes that in all previously published material. Specification and price change privileges reserved. TEKTRONIX and TEK are registered trademarks of Tektronix, Inc. All other trade names referenced are the service marks, trademarks, or registered trademarks of their respective companies.

