

Series 2260B Programmable DC Power Supplies

DATASHEET



Source a wide range of voltages and currents with the 360 W, 720 W, or 1080 W Series 2260B Programmable DC Power Supplies. Choose from 8 versions with voltage output of 30 V, 80 V, 250 V, or 800 V. The 360 W versions can output current of 36 A, 13.5 A, or 4.5 A; the 720 W models can output 72 A, 27 A, or 2.88 A; and the 1080 W instruments can output 108 A or 40.5 A. This wide range of output voltages and current, combined with multiple interface choices, makes the Series 2260B ideal for use in a wide range of applications, including research and design, quality control, and production test.

Applications

- Environmental test, stress test, and accelerated life testing
- LED and high power component testing
- Automotive testing
- Battery research and test
- Production test

Key Features

- 360 W, 720 W, and 1080 W versions with voltages up to 800 V and currents up to 108 A
- Programmable voltage or current rise and fall slew rates prevent damage to low impedance loads from inrush current
- Constant current priority setting reduces voltage and current overshoot when powering LEDs
- Programmable internal resistance simulates battery output
- Choose from analog control, USB, or LAN communications
- Fit six 71 mm wide 360 W units or three 142 mm wide 720 W units or two 214 mm wide 1080 W units in a standard rack width to minimize bench and test system space

Control the Voltage or Current Rise Time to Reduce Inrush Current and Prevent Device Damage

Series 2260B power supplies have programmable rise time (or slew rate) control to prevent potentially dangerous inrush currents from flowing into loads that have low resistance when power is initially supplied. Either voltage or current rise time can be controlled. With voltage slew rate control, voltage rise time can range from a slow, 0.1 V/s to a high speed of 1600 V/s for the 800 V supplies. When operating under constant current control, output current rise time can be programmed from a low slew rate of 0.001 A/s to a maximum value of 216 A/s for the 2260B-30-108. Programming a current rise time puts the Series 2260B

power supplies in a constant current control priority mode in which the current slew rate limits the rate at which the voltage rises across the device under test (DUT.) In addition to controlling rise time, fall time can also be programmed; fall time values can be different from rise time values. Delivery of power to a load can be precisely controlled to prevent overshoot spikes and excessive amounts of inrush current, eliminating damage to components, modules, or devices and generating more precise characteristic I-V curves for components such as LEDs.

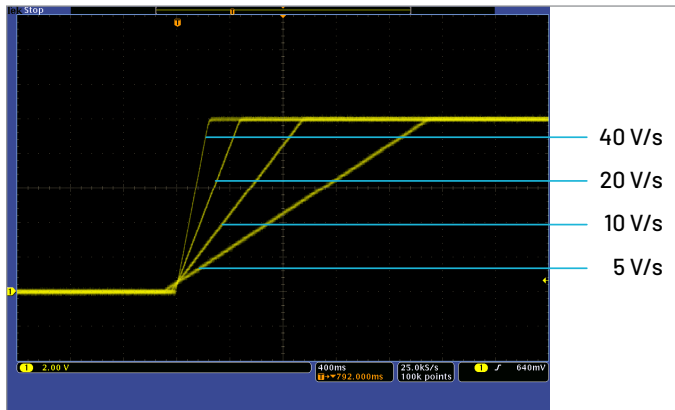

Precisely control voltage rise time with the variable slew rate control.

Emulate the Response of a Battery

Test a circuit or device under the most realistic conditions by applying a test source with the output resistance that is equivalent to the output resistance of the actual source that will be used to power the circuit or device. For example, a battery has a varying internal resistance, and a device powered by a battery will have a voltage applied to the device that is reduced by the voltage drop across the battery's internal resistance. Versions of the Series 2260B power supplies can have an internal resistance up to 555 Ω to simulate a wide range of battery chemistries and load conditions.

Flexible and Fast for Automated Test Systems

With their USB or LAN interfaces, Series 2260B power supplies work in automated systems. In addition, these power supplies have an analog control capability that can control outputs using an external voltage and resistance. Furthermore, Series 2260B power supplies feature fast discharge capability to quickly dissipate the voltage on the output. These power supplies also have a fast, 1 ms transient recovery time to load changes. This combination of fast discharge time and fast transient response minimizes critical test time in automated test systems.

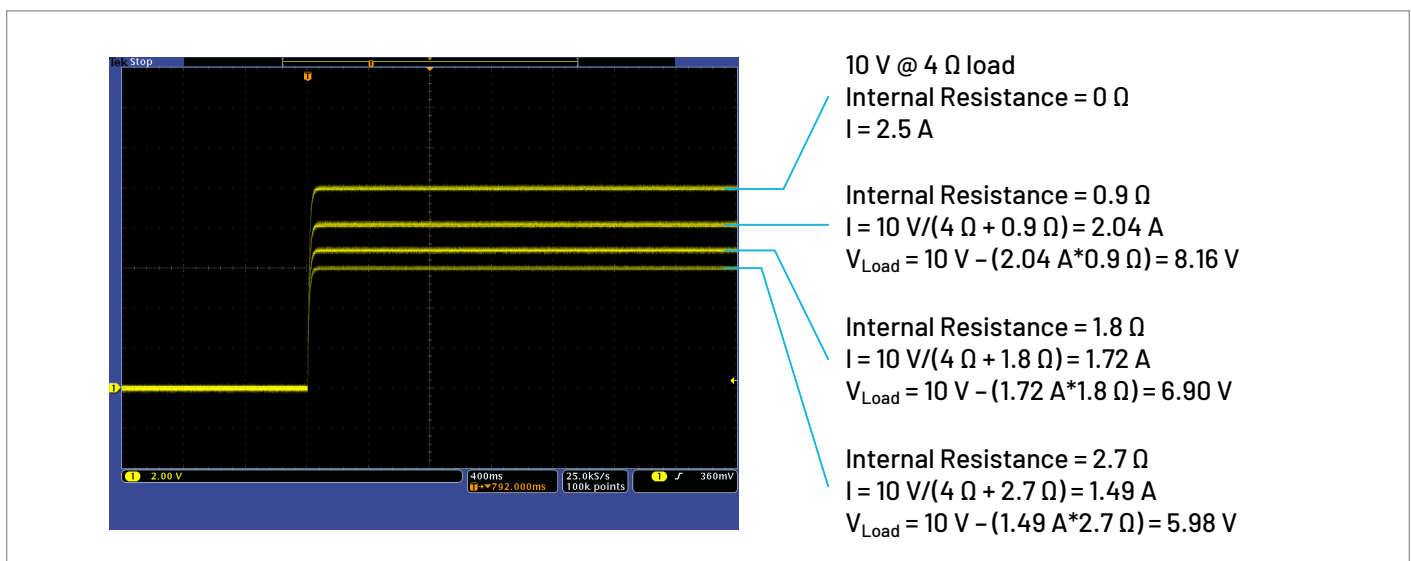

Use the programmable internal resistance to simulate a battery's output. In this example, a 2260B-80-13 power supply is simulating a 10 V battery whose internal resistance is 0 Ω , 0.9 Ω , 1.8 Ω , and 2.7 Ω . The resulting voltage at the output terminals drops from 10 V to 5.98 V due to the voltage drop across the internal resistance of the battery.

Create Custom Voltage Source Waveforms

An internal test sequence mode allows the Series 2260B supplies to output a set of voltage levels for varying time intervals at each level. The test sequence can be stored and used repeatedly to determine DUT performance at number of voltage levels. In addition, the analog input control can be used to create voltage profiles that simulate how a battery responds to a fast changing load current requirement such as a large inrush current. Also, generate a combined DC output level with an AC signal superimposed on it to test how a circuit responds to noise on its DC power source. The analog input control parameter can be either a voltage input or a resistance input. With this analog control capability, numerous types of DC supply signals can be generated to test circuits and devices under a wide range of circumstances.

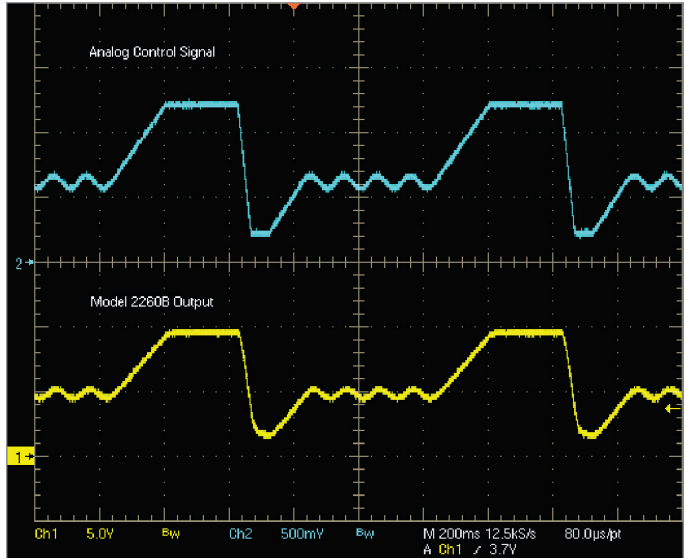

A signal generator (top plot) controls the 2260B to create a complex DC supply waveform (bottom plot) that simulates both a voltage drop due to a large inrush current and noise on the DC supply line.



Rear panel of 360 W models.



Rear panel of 720 W models.



Rear panel of 1080 W models.

Specifications (18°C to 28°C)

	2260B-30-36	2260B-30-72	2260B-30-108	2260B-80-13	2260B-80-27	2260B-80-40	2260B-250-4	2260B-250-9	2260B-250-13	2260B-800-1	2260B-800-2	2260B-800-4
Output Rating												
Voltage	0-30 V	0-30 V	0-30 V	0-80 V	0-80 V	0-80 V	0-250 V	0-250 V	0-250 V	0-800 V	0-800 V	0-800 V
Current	0-36 A	0-72 A	0-108 A	0-13.5 A	0-27 A	0-40.5 A	0-4.5 A	0-9 A	0-13.5 A	0-1.44 A	0-2.88 A	0-4.32 A
Power	360 W	720 W	1080 W	360 W	720 W	1080 W	360 W	720 W	1080 W	360 W	720 W	1080 W
Ripple and Noise (Noise bandwidth 20 MHz, ripple bandwidth 1 MHz)												
CV p-p	60 mV	80 mV	100 mV	60 mV	80 mV	100 mV	80 mV	100 mV	120 mV	150 mV	200 mV	200 mV
CV rms	7 mV	11 mV	14 mV	7 mV	11 mV	14 mV	15 mV	15 mV	15 mV	30 mV	30 mV	30 mV
CC rms	72 mA	144 mA	216 mA	27 mA	54 mA	81 mA	10 mA	20 mA	30 mA	5 mA	10 mA	15 mA
Programming Accuracy												
Voltage	0.1% + 10 mV	0.1% + 10 mV	0.1% + 10 mV	0.1% + 10 mV	0.1% + 10 mV	0.1% + 10 mV	0.1% + 200 mV	0.1% + 200 mV	0.1% + 200 mV	0.1% + 400 mV	0.1% + 400 mV	0.1% + 400 mV
Current	0.1% + 30 mA	0.1% + 60 mA	0.1% + 100 mA	0.1% + 10 mA	0.1% + 30 mA	0.1% + 40 mA	0.1% + 5 mA	0.1% + 10 mA	0.1% + 15 mA	0.1% + 2 mA	0.1% + 4 mA	0.1% + 6 mA
Readback Accuracy												
Voltage	0.1% + 10 mV	0.1% + 10 mV	0.1% + 10 mV	0.1% + 10 mV	0.1% + 10 mV	0.1% + 10 mV	0.1% + 200 mV	0.1% + 200 mV	0.1% + 200 mV	0.1% + 400 mV	0.1% + 400 mV	0.1% + 400 mV
Current	0.1% + 30 mA	0.1% + 60 mA	0.1% + 100 mA	0.1% + 10 mA	0.1% + 30 mA	0.1% + 40 mA	0.1% + 5 mA	0.1% + 10 mA	0.1% + 15 mA	0.1% + 2 mA	0.1% + 4 mA	0.1% + 6 mA
Response Time												
Rise Time	50 ms	50 ms	50 ms	50 ms	50 ms	50 ms	100 ms	100 ms	100 ms	150 ms	150 ms	150 ms
Fall Time (full load)	50 ms	50 ms	50 ms	50 ms	50 ms	50 ms	150 ms	150 ms	150 ms	300 ms	300 ms	300 ms
Fall Time (no load)	500 ms	500 ms	500 ms	500 ms	500 ms	500 ms	1200 ms	1200 ms	1200 ms	2000 ms	2000 ms	2000 ms
Load Transient Recovery Time (load change from 50 to 100%)	1 ms	1 ms	1 ms	1 ms	1 ms	1 ms	2 ms	2 ms	2 ms	2 ms	2 ms	2 ms
Programming Resolution (by PC Remote Control Mode)												
Voltage	1 mV	1 mV	1 mV	2 mV	2 mV	2 mV	5 mV	5 mV	5 mV	14 mV	14 mV	14 mV
Current	1 mA	2 mA	3 mA	1 mA	2 mA	3 mA	1 mA	1 mA	1 mA	1 mA	1 mA	1 mA
Measurement Resolution (by PC Remote Control Mode)												
Voltage	1 mV	1 mV	1 mV	2 mV	2 mV	2 mV	5 mV	5 mV	5 mV	14 mV	14 mV	14 mV
Current	1 mA	2 mA	3 mA	1 mA	2 mA	3 mA	1 mA	1 mA	1 mA	1 mA	1 mA	1 mA
Front Panel Display Accuracy												
Voltage	0.1% ± 20 mV	0.1% ± 20 mV	0.1% ± 20 mV	0.1% ± 20 mV	0.1% ± 20 mV	0.1% ± 20 mV	0.1% ± 200 mV	0.1% ± 200 mV	0.1% ± 200 mV	0.1% ± 400 mV	0.1% ± 400 mV	0.1% ± 400 mV
Current	0.1% ± 40 mA	0.1% ± 70 mA	0.1% ± 100 mA	0.1% ± 20 mA	0.1% ± 40 mA	0.1% ± 50 mA	0.1% ± 5 mA	0.1% ± 10 mA	0.1% ± 20 mA	0.1% ± 2 mA	0.1% ± 4 mA	0.1% ± 6 mA

Regulation (CV) Load: 0.05% of setting + 5 mV. Line: 0.05% of setting + 3 mV.

Regulation (CC) Load: 0.1% of setting + 5 mA. Line: 0.1% of setting + 5 mA.

Voltage Slew Rate Range: Rising and Falling

0.1 V/s to 60 V/s (2260B-30-36, 2260B-30-72, 2260B-30-108).
 0.1 V/s to 160 V/s (2260B-80-13, 2260B-80-27, 2260B-80-40).
 0.1 V/s to 60 V/s (2260B-250-4, 2260B-250-9, 2260B-250-13).
 1 V/s to 1600 V/s (2260B-800-1, 2260B-800-2, 2260B-800-4).

Current Slew Rate Range: Rising and Falling

0.01 A/s to 72.00 A/s (2260B-30-36).
 0.1 A/s to 144.0 A/s (2260B-30-72).
 0.1 A/s to 216.0 A/s (2260B-30-108).
 0.01 A/s to 27.00 A/s (2260B-80-13).
 0.01 A/s to 54.00 A/s (2260B-80-27).
 0.01 A/s to 81.00 A/s (2260B-80-40).
 0.001 A/s to 9.000 A/s (2260B-250-4).
 0.01 A/s to 18.00 A/s (2260B-250-9).
 0.01 A/s to 27.00 A/s (2260B-250-13).
 0.001 A/s to 2.880 A/s (2260B-800-1).
 0.001 A/s to 5.760 A/s (2260B-800-2).
 0.001 A/s to 8.640 A/s (2260B-800-4).

Maximum Voltage Drop in Each Load Wire When Using Remote Sense

30 V and 80 V Models: 0.6 V.
250 V and 800 V Models: 1 V.

Output Delay Time Range

On Delay and Off Delay: 0 s to 99.99 s.

Internal Resistance Range

0.000 Ω to 0.833 Ω (2260B-30-36).
 0.000 Ω to 0.417 Ω (2260B-30-72).
 0.000 Ω to 5.926 Ω (2260B-80-13).
 0.000 Ω to 2.963 Ω (2260B-80-27).
 0.000 Ω to 0.278 Ω (2260B-30-108).
 0.000 Ω to 1.975 Ω (2260B-80-40).
 0.00 Ω to 55.55 Ω (2260B-250-4).
 0.00 Ω to 27.77 Ω (2260B-250-9).
 0.00 Ω to 18.51 Ω (2260B-250-13).
 0.0 Ω to 555.5 Ω (2260B-800-1).
 0.0 Ω to 277.8 Ω (2260B-800-2).
 0.0 Ω to 185.4 Ω (2260B-800-4).

Series and Parallel Capability

Parallel Operation: Up to 3 units including the master unit.
Series Operation: Up to 2 units including the master unit (30 V and 80 V models only).

Protection Functions

OVP: 10% to 100% of rated output voltage range.
Accuracy: $\pm 2\%$ of rated output voltage.
OCP: $\sim 10\%$ to 110% of rated output current range.
Accuracy: $\pm 2\%$ of rated output current.
OTP: Activated by elevated internal temperatures.

Isolation Voltage

500 VDC, output to chassis.

Analog Voltage Control

Voltage Setting Accuracy: $\pm 0.5\%$ of rated output voltage.
Current Setting Accuracy: $\pm 1\%$ of rated output current.

Analog Resistance Control

Voltage Setting Accuracy: $\pm 1.5\%$ of rated output voltage.
Current Setting Accuracy: $\pm 1.5\%$ of rated output current.

General

Analog Control	External voltage or resistance control of output, voltage and current monitor outputs, turn-on, turn-off control, status monitoring, 26-pin connector (rear panel).
Interface	USB: 1.1/2.0, Type A host (front panel), Type B control (rear panel). LAN: 100BASE-T (100 Mb/s).
AC Input Range	85 VAC to 265 VAC, 50/60 Hz, single phase.
Maximum Power Consumption	500 VA (2260B-30-36, 2260B-80-13, 2260B-250-4, 2260B-800-1). 1000 VA (2260B-30-72, 2260B-80-27, 2260B-250-9, 2260B-800-2). 1500 VA (2260B-30-108, 2260B-80-40, 2260B-250-13, 2260B-800-4).
Power Factor	0.97 to 0.99 (typical).
Fan	With thermal sensing control
Environment	Conforms to European Union RoHS Directive. For indoor, non-residential use only. Operating: 0° to 50°C, 20% to 85% relative humidity. Storage: -15° to 70°C, 90% relative humidity or less.
Temperature Coefficient (after 30 minutes warm-up)	Voltage: 100 ppm/°C. Current: 200 ppm/°C.
Safety	NRTL listed to UL61010-1. Conforms to European Union Low Voltage Directive.
EMC	Conforms to European Union EMC Directive.
Dimensions, Weight	360 W Models: 71 mm wide × 124 mm high × 350 mm deep (2.80 in. × 4.88 in. × 13.78 in.). Net Weight: Approximately 3 kg (6.6 lb.). Shipping Weight: 4.3 kg (9.5 lb.). 720 W Models: 142.5 mm wide × 124 mm high × 350 mm deep (5.61 in. × 4.88 in. × 13.78 in.). Net Weight: Approximately 5 kg (11 lb.). Shipping Weight: 6.8 kg (15 lb.). 1080 W Models: 214 mm wide × 124 mm high × 350 mm deep (8.43 in × 4.88 in × 13.78 in.). Net Weight: Approximately 7.5 kg (16.5 lb.). Shipping Weight: 9.6 kg (21 lb.).
Warranty	3 years.

Ordering Information

2260B-30-36	Programmable DC 360 W Power Supply, 30 V, 36 A
2260B-80-13	Programmable DC 360 W Power Supply, 80 V, 13.5 A
2260B-250-4	Programmable DC 360 W Power Supply, 250 V, 4.5 A
2260B-30-72	Programmable DC 720 W Power Supply, 30 V, 72 A
2260B-80-27	Programmable DC 720 W Power Supply, 80 V, 27 A
2260B-800-2	Programmable DC 720 W Power Supply, 800 V, 2.88 A
2260B-30-108	Programmable DC 1080 W Power Supply, 30 V, 108 A
2260B-80-40	Programmable DC 1080 W Power Supply, 80 V, 40.5 A

Supplied Accessories

2260B Basic Accessory Kit (for 30 V and 80 V models)
2260B-010 Basic Accessories Kit (for 250 V/800 V Series)
Test Lead Set (for 30 V and 80 V models)
2260-009 Test Lead (for 250 V/800 V models)
USB Cable
Power Cord
Certificate of Traceable Calibration

Available Accessories

2260B-RMK-EIA

Rack Mount Kit (EIA racks)

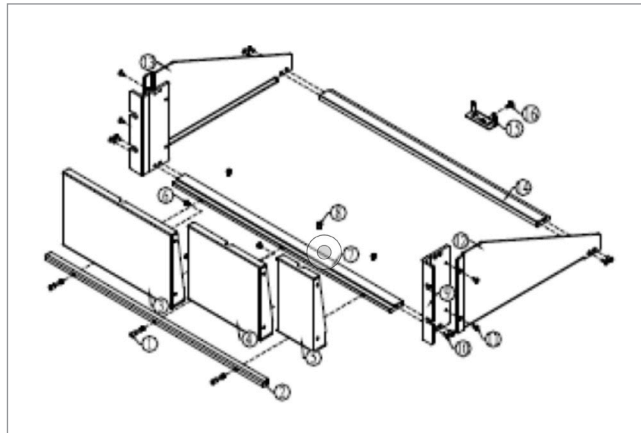

2260B-RMK-EIA: Rack mount kit (EIA racks).

Available Services

Model Number*-EW	3-year factory warranty extended to 1 additional year from date of shipment
Model Number*-5Y-EW	3-year factory warranty extended to 5 years from date of shipment
C/Model Number*-3Y-STD	KeithleyCare® 3 Year Standard Calibration Plan
C/Model Number*-3Y-DAT	KeithleyCare 3 Year Calibration with Data Plan
C/Model Number*-5Y-STD	KeithleyCare 5 Year Standard Calibration Plan
C/Model Number*-5Y-DAT	KeithleyCare 5 Year Calibration with Data Plan

* Replace the specific power supply model number in place of model number to generate the appropriate model number for a service item. For example, for 2260B-30-36, a 1-year extended warranty model number would be 2260B-30-36-1-EW.

Contact Information:

Australia 1 800 709 465
Austria* 00800 2255 4835
Balkans, Israel, South Africa and other ISE Countries +41 52 675 3777
Belgium* 00800 2255 4835
Brazil +55 (11) 3530-8901
Canada 1 800 833 9200
Central East Europe / Baltics +41 52 675 3777
Central Europe / Greece +41 52 675 3777
Denmark +45 80 88 1401
Finland +41 52 675 3777
France* 00800 2255 4835
Germany* 00800 2255 4835
Hong Kong 400 820 5835
India 000 800 650 1835
Indonesia 007 803 601 5249
Italy 00800 2255 4835
Japan 81 (3) 6714 3086
Luxembourg +41 52 675 3777
Malaysia 1 800 22 55835
Mexico, Central/South America and Caribbean 52 (55) 88 69 35 25
Middle East, Asia, and North Africa +41 52 675 3777
The Netherlands* 00800 2255 4835
New Zealand 0800 800 238
Norway 800 16098
People's Republic of China 400 820 5835
Philippines 1 800 1601 0077
Poland +41 52 675 3777
Portugal 80 08 12370
Republic of Korea +82 2 565 1455
Russia / CIS +7 (495) 6647564
Singapore 800 6011 473
South Africa +41 52 675 3777
Spain* 00800 2255 4835
Sweden* 00800 2255 4835
Switzerland* 00800 2255 4835
Taiwan 886 (2) 2656 6688
Thailand 1 800 011 931
United Kingdom / Ireland* 00800 2255 4835
USA 1 800 833 9200
Vietnam 12060128

* European toll-free number. If not accessible, call: +41 52 675 3777

Rev. 02.2022



Find more valuable resources at TEK.COM

Copyright © Tektronix. All rights reserved. Tektronix products are covered by U.S. and foreign patents, issued and pending. Information in this publication supersedes that in all previously published material. Specification and price change privileges reserved. TEKTRONIX and TEK are registered trademarks of Tektronix, Inc. All other trade names referenced are the service marks, trademarks or registered trademarks of their respective companies.

062026 KEI 1KW-73968-2

