

## Series 2290 High Voltage Power Supplies

### DATA SHEET



Series 2290 High Voltage Power Supplies facilitate high voltage device and material testing, as well as high energy physics experimentation. The 2290-5 5kV Power Supply provides voltage outputs up to 5000 V, and the 2290-10 10 kV Power Supply offers up to 10,000 V. The 2290-5 has a 5 mA current capacity and the 2290-10 has a 1 mA current capacity. These supplies measure both output voltage with 1V resolution and output current with 1 µA resolution. In addition to the voltage and current output displays, a third display shows one of four settings: output voltage, voltage limit, current limit, or current trip. These values can be set precisely with the front panel keypad. The settings can also be programmed over the IEEE-4888 interface, or the output voltage can be set with an analog control voltage.

### Low Noise Ensures Accurate Low Level Measurements

Low output noise is essential when using sensitive measurement instruments to make leakage current or high resistivity measurements. The maximum output ripple for the 2290-10 is less than 1 V<sub>RMS</sub>. The maximum output ripple of the 2290-5 is 100 mV<sub>RMS</sub>. Two selectable, internal filters on the 2290-5 reduce the maximum output ripple to only 3 mV<sub>RMS</sub>. Extremely low noise from both power supplies enables sensitive measurement instruments to make accurate current measurements down to picoamp levels.

### Key Features

- Source voltages up to 5 kV and 10 kV
- 1 µA current measurement resolution
- Low noise for precision sourcing and sensitive measurements; selectable filters reduce noise to less than 3 mV<sub>RMS</sub> on the 5 kV supply
- Safety interlock controls high voltage output
- IEEE-488 programmable
- Protection module prevents damage to low voltage instrumentation

### Protecting User and Instrumentation

Series 2290 Power Supplies and a 2290-PM-200 SMU Protection Module protect both user and instrumentation from hazardous voltages. An interlock circuit built into the power supplies can be used to ensure that the output voltage is disabled if a high voltage test fixture access



The 2290-PM-200 Protection Module protects low voltage measurement equipment from voltages greater than 200V.

**TYPICAL APPLICATIONS**

- High voltage device breakdown testing
- High voltage component testing
- Insulation testing
- High voltage resistivity measurements
- High energy physics research

door is open. In addition, all Series 2290 power supplies have low voltage analog outputs to permit safe monitoring of the high voltage and the output current.

When low voltage measurement instrumentation is used in the high voltage circuit, the protection module safely clamps the voltage across the instrument to a maximum value of 200V even when a device under test (DUT) breaks down. Thus, a Series 2290 Power Supply, 2290-PM-200 Protection Module, and Keithley accessories provide all the elements for building a safe, high voltage test environment.

**Make Precise Current Measurements Lower Than 1  $\mu$ A**

Use a sensitive Keithley measurement instrument, such as a Keithley SourceMeter<sup>®</sup> SMU instrument, to measure current drawn by the device under test (DUT) that is below the sensitivity of the Series 2290 Power Supplies. Keithley SourceMeter SMU instruments can provide sensitivity as low as 0.1fA. The following diagram shows how the 2290-PM-200

Protection Module protects the low voltage SourceMeter SMU instrument from high voltages when the DUT breaks down. The leakage current of the Protection Module limits the measurement resolution to picoamp levels, which is five decades more sensitive than the current measurement resolution of the Series 2290 Power Supplies. Keithley can provide a complete high voltage test capability with the most current measurement sensitivity available anywhere.

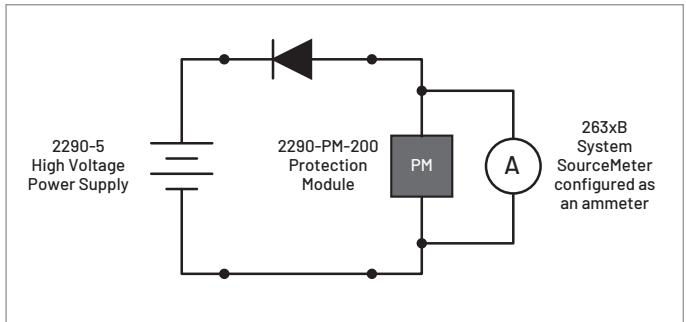

Reverse breakdown testing of a high voltage diode using a Keithley SourceMeter SMU instrument to measure leakage current. The 2290-PM-200 SMU Protection Module protects the SourceMeter SMU instrument from high voltage when the diode breaks down.

**Easily Automate a High Voltage Test System**

The Series 2290's IEEE-488 interface allows the creation of an automated high voltage test system. Software drivers are supplied to simplify and accelerate test system development. This further enhances safety as the high voltage can be controlled from a remote location.

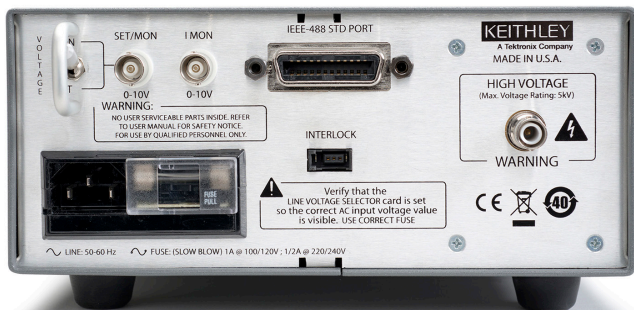

2290-5 rear panel showing the IEEE-488 interface connector, high voltage output connector, analog control/output connectors, and interlock connector.



2290-10 rear panel showing the IEEE-488 interface connector, RS-232 interface connector, high voltage output connector, analog control/output connectors, and interlock connector.

## 2290-5 Specifications

### 5 kV Voltage Power Supply Characteristics

#### Conditions

This document contains specifications and supplemental information for the 2290-5 High Voltage Power Supply. Specifications are the standards against which the 2290-5 is tested. Upon leaving the factory, the 2290-5 meets these specifications. Characteristics, supplemental characteristics, and typical values are not warranted, apply at 18°C to 28°C, <70% relative humidity, and are provided solely as useful information.

#### DC Accuracy Specifications

<b>Voltage Set Accuracy<sup>2</sup></b>	±(0.01% of setting + 2.5 V).
<b>Voltage Display Accuracy</b>	Voltage set accuracy ±1 V, typical (±2 V, maximum).
<b>Current Set Accuracy<sup>5</sup></b>	±(0.01% of setting + 2.5 µA).
<b>Current Display Accuracy</b>	±1 µA, typical (±2 µA, maximum).

#### Characteristics

<b>Voltage Range</b>	<table border="1"> <thead> <tr> <th>Output Voltage<sup>1</sup></th> <th>Maximum Output Current</th> <th>Conditions</th> </tr> </thead> <tbody> <tr> <td>50 to +5000 V DC</td> <td>5.000 mA DC</td> <td>No filter</td> </tr> <tr> <td>50 to +3000 V DC</td> <td>5.000 mA DC</td> <td>Filter 1</td> </tr> <tr> <td>50 to +5000 V DC</td> <td>3.000 mA DC</td> <td>Filter 2</td> </tr> </tbody> </table>			Output Voltage <sup>1</sup>	Maximum Output Current	Conditions	50 to +5000 V DC	5.000 mA DC	No filter	50 to +3000 V DC	5.000 mA DC	Filter 1	50 to +5000 V DC	3.000 mA DC	Filter 2	
Output Voltage <sup>1</sup>	Maximum Output Current	Conditions														
50 to +5000 V DC	5.000 mA DC	No filter														
50 to +3000 V DC	5.000 mA DC	Filter 1														
50 to +5000 V DC	3.000 mA DC	Filter 2														
<b>Voltage Resolution</b>	1 V (set and display).															
<b>Voltage Limit Range</b>	0 to 100% full scale.															
<b>Voltage Regulation<sup>3</sup></b>	<b>Line:</b> 0.001% for ±10% line voltage change. <b>Load:</b> 0.005% for 100% load change, typical.															
<b>Output Ripple (10 kHz–100 kHz)<sup>4</sup></b>	0.002% of full scale, VRMS, maximum – No filter. 1.0 mVRMS @ 1 kV – Filter 1 or Filter 2. 2.0 mVRMS @ 3 kV – Filter 1 or Filter 2. 3.0 mVRMS @ 5 kV – Filter 2.															
<b>Rise Time (full load)<sup>6,7</sup></b>	1.5 seconds for 0 to within 1 V of 5000 VDC – No filter. 3 seconds for 0 to within 1 V of 3000 VDC – Filter 1. 4 seconds for 0 to within 1 V of 5000 VDC – Filter 2															
<b>Discharge Time (full load)<sup>6,7</sup></b>	1 second for 5000 VDC to 1VDC – No filter. 3 seconds for 3000 VDC to 1VDC – Filter 1. 4 seconds for 5000 VDC to 1VDC – Filter 2															
<b>Discharge Time (no load)<sup>6</sup></b>	<12 seconds (to <50 VDC) – No filter. <30 seconds (to <50 VDC) – Filter 1 or Filter 2.															
<b>Settling Time<sup>6,7</sup></b>	From 0 to programmed voltage; to within 99.9% of final value within 3 seconds.															
<b>Recovery Time<sup>6,7</sup></b>	120 ms for 40% step change in load current (typical).															
<b>Current Limit and Trip Range</b>	<table border="1"> <thead> <tr> <th>Current Limit and Trip Range</th> <th>Voltage Range</th> <th>Filter</th> </tr> </thead> <tbody> <tr> <td>0.4 mA to 5.25 mA</td> <td rowspan="2">0 V to 1.5 kV</td> <td>No filter or Filter 1</td> </tr> <tr> <td>0.4 mA to 3.25 mA</td> <td>Filter 2</td> </tr> <tr> <td>0.5 mA to 5.25 mA</td> <td rowspan="2">1.5 kV to 5.0 kV</td> <td>No filter or Filter 1</td> </tr> <tr> <td>0.4 mA to 3.25 mA</td> <td>Filter 2</td> </tr> </tbody> </table>			Current Limit and Trip Range	Voltage Range	Filter	0.4 mA to 5.25 mA	0 V to 1.5 kV	No filter or Filter 1	0.4 mA to 3.25 mA	Filter 2	0.5 mA to 5.25 mA	1.5 kV to 5.0 kV	No filter or Filter 1	0.4 mA to 3.25 mA	Filter 2
Current Limit and Trip Range	Voltage Range	Filter														
0.4 mA to 5.25 mA	0 V to 1.5 kV	No filter or Filter 1														
0.4 mA to 3.25 mA		Filter 2														
0.5 mA to 5.25 mA	1.5 kV to 5.0 kV	No filter or Filter 1														
0.4 mA to 3.25 mA		Filter 2														
<b>Current Resolution</b>	1 µA.															

<b>Stability</b>	±0.01% per hour; <0.03% per eight hours.
<b>Temperature Drift</b>	50 ppm/ °C, 0°C to 40 °C, typical.
<b>Protection</b>	Arc and short circuit protected; programmable voltage and current limits and current trip.

#### Monitor Outputs

<b>Output Scale</b>	0 to +10 V to full scale.
<b>Current Rating</b>	10 mA maximum.
<b>Output Impedance</b>	<1 Ω.
<b>Accuracy</b>	±0.2% of full scale with a 100 kΩ load, minimum.
<b>Update Rate</b>	8 Hz.

#### External Voltage Set

<b>Input Scale</b>	0 to +10 V for 0 to full scale.
<b>Input Impedance</b>	1 MΩ.
<b>Accuracy</b>	±0.2% of full scale.
<b>Update Rate</b>	16 Hz.
<b>Output Slew Rate</b>	<(rise time + 0.3 seconds) for 0 to full range under full load.

## General

<b>Input power</b>	55 watts.
<b>2290-5 Input Voltage</b>	120 V ±10%, 50 or 60 Hz.
<b>2290E-5 Input Voltage</b>	240 V ±10%, 50 or 60 Hz.
<b>2290J-5 Input Voltage</b>	100 V ±10%, 50 or 60 Hz.
<b>Rear Panel Connectors</b>	SHV female (Kings type 1704-1 or equivalent). Output high-voltage connector GPIB connector. BNC Connector (two): Voltage set/Voltage monitor; Current monitor.
<b>Toggle Switch</b>	Voltage setting or Voltage monitor.
<b>High-voltage Safety Interlock</b>	<b>Connector:</b> 3-pin press-in connector, 3M part number 37103-A165-00E-MB. <b>Pin 1:</b> 5V out, 1.5 mA maximum out. <b>Pin 2:</b> Input: High-voltage output enabled: 3–24 VDC. High-voltage output disabled: <1.2 VDC. <b>Pin 3:</b> Chassis ground through a 100 Ω resistor.
<b>Interface Protocol</b>	IEEE-488.1.
<b>Operating Environment</b>	0°C to 40 °C; non-condensing.
<b>Dimensions</b>	89 mm high × 206 mm wide × 406 mm deep (3.5 in. × 8.1 in. × 16 in.).
<b>Weight</b>	5.5 kg (12 lb).
<b>Safety</b>	Conformance to European Union low voltage directive.
<b>Warranty</b>	One year.
<b>Warm-up Time</b>	One hour.

#### Notes

1. The output voltage can be programmed to a voltage lower than 50 V; however, performance below 50 V is not specified.
2. Add ±2.5 VDC when Filter 1 or Filter 2 is enabled.
3. Regulation specifications apply for greater than 25 VDC (with full load), or 50 VDC (with no load). Below these values, the unit may not regulate correctly.
4. Peak-to-peak values are within five times the RMS value.
5. Add 2.5 μA offset when Filter 1 or Filter 2 is enabled.
6. Times apply with the current limit set to 105% of full scale.
7. Loads are fully resistive.

## 2290-10 Specifications

### 10 kV Voltage Power Supply Characteristics

#### Conditions

This document contains specifications and supplemental information for the 2290-10 High Voltage Power Supply. Specifications are the standards against which the 2290-10 is tested. Upon leaving the factory, the 2290-10 meets these specifications. Characteristics, supplemental characteristics, and typical values are not warranted, apply at 18°C to 28°C, <70% relative humidity, and are provided solely as useful information.

#### DC Accuracy Specifications

<b>Voltage Set Accuracy</b>	±0.06% of full scale.
<b>Voltage Display Accuracy</b>	Voltage set accuracy ±1 V, typical (±2 V, maximum).
<b>Current Set Accuracy</b>	0.5% of full scale.
<b>Current Display Accuracy</b>	±1 µA, typical (±2 µA, maximum).

#### Characteristics

<b>Voltage Range</b>	<b>Output Voltage<sup>1</sup></b>	<b>Maximum Output Current</b>
	+100 to +10,000 V DC	1.000 mA DC
<b>Voltage Resolution</b>	1 V (set and display).	
<b>Voltage Limit Range</b>	0 to 100% full scale.	
<b>Voltage Regulation<sup>2</sup></b>	<b>Line:</b> 0.001% for ±10% line voltage change. <b>Load:</b> 0.04% for 100% load change, typical.	
<b>Output Ripple (300 Hz–300 kHz)</b>	0.01% of full scale, $V_{RMS}$ .	
<b>Rise Time (from high voltage turn on to final value under full load)<sup>3,4</sup></b>	<6 seconds to within 1 V of the final value.	
<b>Discharge Time (to 0 V under full load)<sup>3,4</sup></b>	1 second to under 10 V.	
<b>Discharge Time (no load)<sup>3</sup></b>	<6 seconds (to <1% of full scale voltage with no load, typical).	
<b>Settling Time<sup>3,4</sup></b>	<4 seconds to within 1 V of the final value.	
<b>Recovery Time<sup>3,4</sup></b>	120 ms for 40% step change in load current (typical).	
<b>Current Limit Range</b>	0 to 105% of full scale.	
<b>Current Resolution</b>	1 µA.	
<b>Trip Current Range</b>	10 µA to 105% of full scale (excluding stored output charge).	
<b>Output Stored Charge</b>	<20 µC maximum.	
<b>Trip Response Time</b>	<10 ms.	
<b>Stability</b>	±0.01% per hour; <0.03% per eight hours.	
<b>Temperature Drift</b>	50 ppm/°C, 0°C to 40°C, typical.	
<b>Protection</b>	Arc and short circuit protected; programmable voltage and current limits and current trip.	

**Monitor Outputs**

<b>Output Scale</b>	0 to +10 V for 0 V to full scale.
<b>Current Rating</b>	10 mA maximum.
<b>Output Impedance</b>	100 $\Omega$ .
<b>Accuracy</b>	$\pm 0.2\%$ of full scale with a 1 M $\Omega$ load, minimum.
<b>Update Rate</b>	87.5 Hz.

**External Voltage Set**

<b>Input Scale</b>	0 to +10 V for 0 to full scale.
<b>Input Impedance</b>	1 M $\Omega$ .
<b>Accuracy</b>	$\pm 0.2\%$ of full scale.
<b>Update Rate</b>	87.5 Hz.
<b>Output Slew Rate (5% to 95% under full load)</b>	<3 seconds

**General**

<b>Input Power</b>	75 watts.
<b>Input Voltage</b>	90 VAC to 264 VAC, 47 Hz to 63 Hz.
<b>Rear Panel Connectors</b>	<b>Output High-voltage Connector:</b> SHV female (Kings type 1764-1 or equivalent). <b>BNC Connector (three):</b> Input, voltage monitor; current monitor. GPIB connector, 23-pin. RS-232, 9-pin D-sub.
<b>High-voltage Safety Interlock</b>	<b>Connector:</b> 3-pin press-in connector, 3M part number 37103-A165-00E-MB. <b>Pin 1:</b> 5 V out, 70 mA maximum out. <b>Pin 2:</b> Input: High-voltage output enabled: 5 VDC. High-voltage output disabled: 0 VDC or open connection. <b>Pin 3:</b> Chassis ground.
<b>Interface Protocol</b>	IEEE-488.1.
<b>Operating Environment</b>	For indoor, non-residential use only. 0°C to 40°C; non-condensing.
<b>Dimensions</b>	89 mm high $\times$ 206 mm wide $\times$ 406 mm deep (3.5 in $\times$ 8.1 in $\times$ 16 in).
<b>Weight</b>	3.7 kg (8 pounds).
<b>Safety</b>	Conformance to European Union low voltage directive.
<b>Warranty</b>	One year.
<b>Warm-up Time</b>	One hour.

**Notes**

1. The output voltage can be programmed to voltages below 100 V, but accuracy below 100 V is not specified.
2. Regulation specifications apply for greater than 100 V.
3. Times apply with the current limit set to 105% of full scale.
4. Loads are fully resistive.

## 2290-PM-200 Specifications

### SMU Protection Module Characteristics

#### CONDITIONS

This document contains specifications and supplemental information for the 2290-PM-200 Protection Module. Specifications are the standards against which the 2290-PM-200 is tested. Upon leaving the factory, the 2290-PM-200 meets these specifications. Characteristics, supplemental characteristics, and typical values are not warranted, apply at 18°C to 28°C, <70 percent relative humidity, and are provided solely as useful information.

#### Characteristics

<b>Leakage</b>	<10 pA at 200 V typical.
<b>DC current Carrying Capability</b>	<1.5 A in unclamped condition.
<b>Pulsed Current Carrying Capability</b>	10 A maximum at 1% duty cycle in unclamped condition.
<b>Maximum Protection Active Current</b>	Current must be limited to <120 mA in clamped condition (~230 V).
<b>Protection voltage</b>	220 VDC minimum, 230 VDC typical, 240 VDC maximum.
<b>Dimensions</b>	81.28 mm long × 81.53 mm wide × 54.10 mm high (3.20 in. long × 3.21 in. wide × 2.13 in. high). Maximum length with high-voltage connectors: 5.34 in (135.64mm).
<b>Weight</b>	0.25 kg (0.55 lb).

## General

<b>Warranty</b>	1 year.
<b>Safety</b>	Listed to UL 61010-1:2012 (3rd edition). Conforms to European Union Low Voltage Directive.
<b>Connectors</b>	
<b>High Voltage</b>	5 kV connector: male SHV, 0.38 inches (9.35 mm) diameter, Kings 1704-1. 10 kV connector: female SHV, 0.535 inches (13.59 mm) diameter, Kings 1764-1.
<b>Low Voltage</b>	Triax, female, quantity of 2.
<b>Safety</b>	Screw ground terminal, quantity of 2.

## Ordering Information

<b>2290-5</b>	5 kV Power Supply, 120 VAC Nominal Input Voltage
<b>2290E-5</b>	5 kV Power Supply, 240 VAC Nominal Input Voltage
<b>2290J-5</b>	5 kV Power Supply, 100 VAC Nominal Input Voltage
<b>2290-10</b>	10 kV Power Supply

## Supplied Accessories

Power cord

## Available Accessories

### For 2290-5

<b>2290-5-SHV</b>	5 kV SHV Female-SHV Female Cable, 3 m (10 ft)
<b>2290-5-MHV</b>	5 kV SHV Female-MHV Male Cable, 3 m (10 ft)
<b>2290-5-SHVBH</b>	5 kV SHV Male Bulkhead Connector

### For 2290-10

<b>2290-10-SHVUC</b>	10 kV SHV Male to Unterminated Cable, 3 m (10 ft)
<b>2290-10-SHV</b>	10 kV SHV Male-SHV Male Cable, 3m (10 ft)
<b>2290-10-SHVBH</b>	10 kV SHV Female Bulkhead Connector

### For Both

<b>2290-PM-200</b>	10 kV Protection Module
<b>2290-INT-CABLE</b>	3-Pin Connector to Unterminated Interlock Cable
<b>4299-7</b>	Fixed Shelf Rack Mount Kit
<b>KPCI-488LPA</b>	IEEE-488.2 Interface Board for the PCI Bus
<b>KUSB-488B</b>	IEEE-488.2 USB-GPIB Interface Adapter for USB port with built-in 2 m (6.6 ft) cable
<b>7007-05</b>	Double Shielded Premium IEEE-488 Interface Cable, 0.5 m (1.6 ft)
<b>7007-1</b>	Double Shielded Premium IEEE-488 Interface Cable, 1 m (3.2 ft)

## Available Services

<b>Model Number*-EW</b>	1 Year Factory Warranty extended one additional year from date of shipment
<b>Model Number-3Y-EW</b>	1 Year Factory Warranty extended to 3 years from date of shipment
<b>Model Number-5Y-EW</b>	1 Year Factory Warranty extended to 5 years from date of shipment
<b>C/Model Number-3Y-STD</b>	KeithleyCare 3 Year Standard Calibration Plan
<b>C/Model Number-3Y-DATA</b>	KeithleyCare 3 Year Calibration with Data Plan
<b>C/Model Number-5Y-STD</b>	KeithleyCare 5 Year Standard Calibration Plan
<b>C/Model Number-5Y-DATA</b>	KeithleyCare 5 Year Calibration with Data Plan

\*Insert number. Examples: 2290-5-EW, 2290E-10-3Y-STD

## Contact Information:

Australia 1 800 709 465  
Austria\* 00800 2255 4835  
Balkans, Israel, South Africa and other ISE Countries +41 52 675 3777  
Belgium\* 00800 2255 4835  
Brazil +55(11) 3530-8901  
Canada 1 800 833 9200  
Central East Europe / Baltics +41 52 675 3777  
Central Europe / Greece +41 52 675 3777  
Denmark +45 80 88 1401  
Finland +41 52 675 3777  
France\* 00800 2255 4835  
Germany\* 00800 2255 4835  
Hong Kong 400 820 5835  
India 000 800 650 1835  
Indonesia 007 803 601 5249  
Italy 00800 2255 4835  
Japan 81(3) 6714 3086  
Luxembourg +41 52 675 3777  
Malaysia 1 800 22 55835  
Mexico, Central/South America and Caribbean 52 (55) 88 69 35 25  
Middle East, Asia, and North Africa +41 52 675 3777  
The Netherlands\* 00800 2255 4835  
New Zealand 0800 800 238  
Norway 800 16098  
People's Republic of China 400 820 5835  
Philippines 1 800 1601 0077  
Poland +41 52 675 3777  
Portugal 80 08 12370  
Republic of Korea +82 2 565 1455  
Russia / CIS +7(495) 6647564  
Singapore 800 6011 473  
South Africa +41 52 675 3777  
Spain\* 00800 2255 4835  
Sweden\* 00800 2255 4835  
Switzerland\* 00800 2255 4835  
Taiwan 886 (2) 2656 6688  
Thailand 1 800 011 931  
United Kingdom / Ireland\* 00800 2255 4835  
USA 1 800 833 9200  
Vietnam 12060128

\*European toll-free number. If not  
accessible, call: +41 52 675 3777

Rev. 02.2022



Find more valuable resources at [TEK.COM](http://TEK.COM)

Copyright © Tektronix. All rights reserved. Tektronix products are covered by U.S. and foreign patents, issued and pending. Information in this publication supersedes that in all previously published material. Specification and price change privileges reserved. TEKTRONIX and TEK are registered trademarks of Tektronix, Inc. All other trade names referenced are the service marks, trademarks or registered trademarks of their respective companies.

071026 KEI 1KW-61672-1

