

2651A 50 A, High Power System SourceMeter® SMU Instrument

DATASHEET



The high power 2651A SourceMeter SMU Instrument is specifically designed to characterize and test high power electronics. This SMU instrument can help you improve productivity in applications across the R&D, reliability, and production spectrums, including high brightness LEDs, power semiconductors, DC-DC converters, batteries, solar cells, and other high power materials, components, modules, and subassemblies.

The 2651A offers a highly flexible, four-quadrant voltage and current source/load coupled with precision voltage and current meters. It can be used as a:

- Semiconductor characterization instrument
- V or I waveform generator
- V or I pulse generator
- Precision power supply
- True current source
- Digital multimeter (DCV, DCI, ohms, and power with 6½-digit resolution)
- Precision electronic load

Key Features

- Source or sink:
 - 2,000 W of pulsed power (± 40 V, ± 50 A)
 - 200 W of DC power (± 10 V @ ± 20 A, ± 20 V @ ± 10 A, ± 40 V @ ± 5 A)
- Easily connect two units (in series or parallel) to create solutions up to ± 100 A or ± 80 V
- 1 pA resolution enables precise measurement of very low leakage currents
- 1 μ s per point (1 MHz), 18-bit sampling, accurately characterizes transient behavior
- 1% to 100% pulse duty cycle for pulse width modulated (PWM) drive schemes and device-specific drive stimulus
- Combines a precision power supply, current source, DMM, arbitrary waveform generator, V or I pulse generator with measurement, electronic load, and trigger controller—all in one instrument

Typical Applications

- Power semiconductor, HBLED, and optical device characterization and testing
- Solar cell characterization and testing
- Characterization of GaN, SiC, and other compound materials and devices
- Semiconductor junction temperature characterization
- High speed, high precision digitization
- Electromigration studies
- High current, high power device testing

Two Measurement Modes: Digitizing or Integrating

Precisely characterize transient and steady-state behavior, including rapidly changing thermal effects, with the two measurement modes in the 2651A. Each mode is defined by its independent analog-to-digital (A/D) converters.

The Digitizing Measurement mode enables 1 μ s per point measurements. Its 18-bit A/D converters allow you to precisely measure transient characteristics. For more accurate measurements, use its Integrating Measurement mode, which is based on 22-bit A/D converters.

Two A/D converters are used with each measurement mode (one for current and the other for voltage), which run simultaneously for accurate source readback that does not sacrifice test throughput.

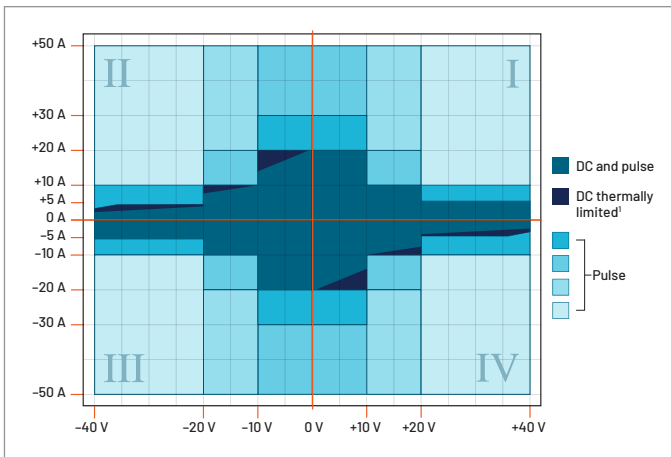

The 2651A can source or sink up to ± 40 V and ± 50 A.

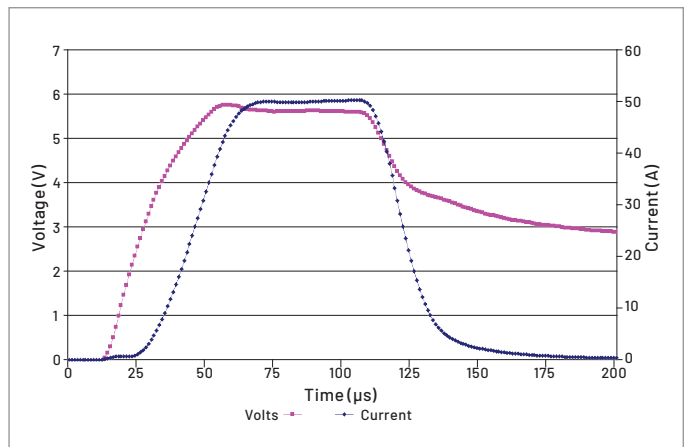

The dual digitizing A/D converters sample at up to 1 μ s/point, enabling full simultaneous characterization of both current and voltage waveforms.

Maximum Output Power	Voltage	Current
Quadrant II	-10 V @ 13 A -20 V @ 7.7 A -40 V @ 3.3 A	4.3 A @ -20 V 10 A @ -10 V 20 A @ -1.3 V
Quadrant IV	10 V @ -13 A 20 V @ -7.7 A 40 V @ -3.3 A	-4.3 A @ 20 V -10 A @ 10 V -20 A @ 1.3 V

High Speed Pulsing

The 2651A minimizes the unwanted effects of self heating during tests by accurately sourcing and measuring pulses as short as 100 μ s. Additional control flexibility enables you to program the pulse width from 100 μ s to DC and the duty cycle from 1% to 100%. A single unit can pulse up to 50 A; combine two units to pulse up to 100 A.

Expansion Capabilities

Through TSP-Link Technology technology, multiple 2651As and selected Series 2600B SMU instruments can be combined to form a larger integrated system with up to 64 channels. Precision timing and tight channel synchronization are guaranteed with built-in 500 ns trigger controllers. True SMU instrument-per-pin testing is assured with the fully isolated, independent channels of the SourceMeter SMU instruments.

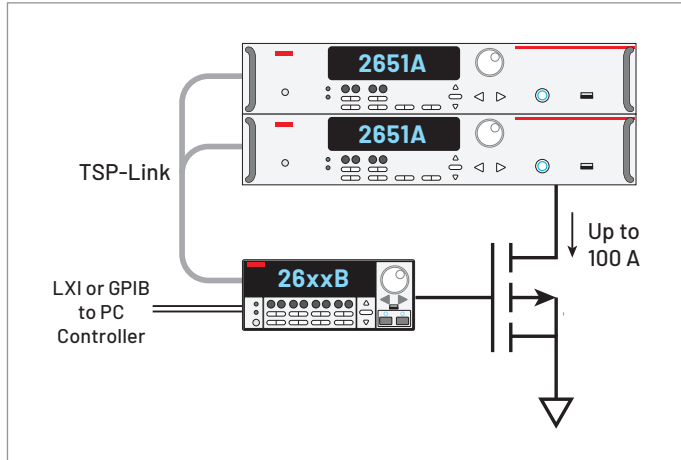

Keithley's TSP and TSP-Link Technologies enable true SMU-per-pin testing without the power and/or channel limitations of a mainframe-based system.

Also, when two 2651As are connected in parallel with TSP-Link Technology, the current range is expanded from 50 A to 100 A. When two units are connected in series, the voltage range is expanded from 40 V to 80 V. Built-in intelligence simplifies testing by enabling the units to be addressed as a single instrument, thus creating an industry-best dynamic range (100 A to 1 pA). This capability enables you to test a much wider range of power semiconductors and other devices.

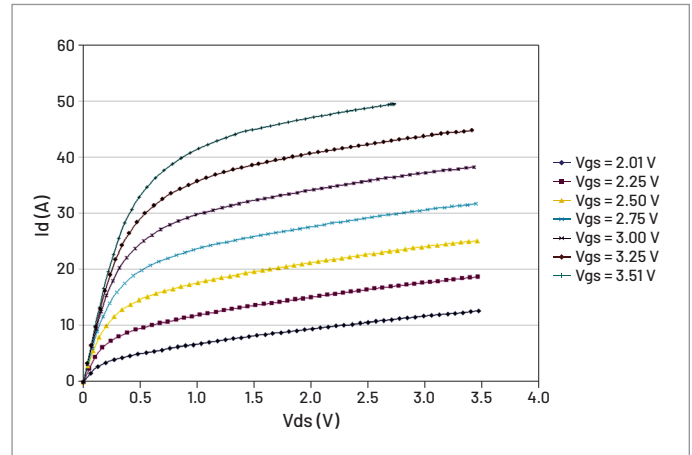

Precision measurements to 50 A (100 A with two units) enable a more complete and accurate characterization.

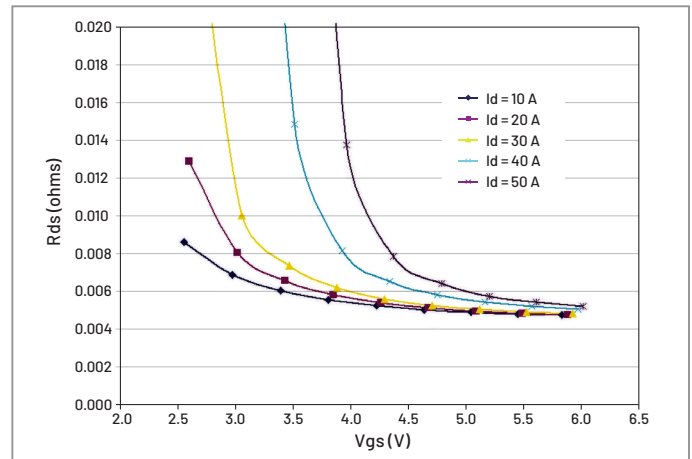

1 μ V measurement resolution and current sourcing up to 50 A (100 A with two units) enable low-level R_{ds} measurements to support next-generation devices.

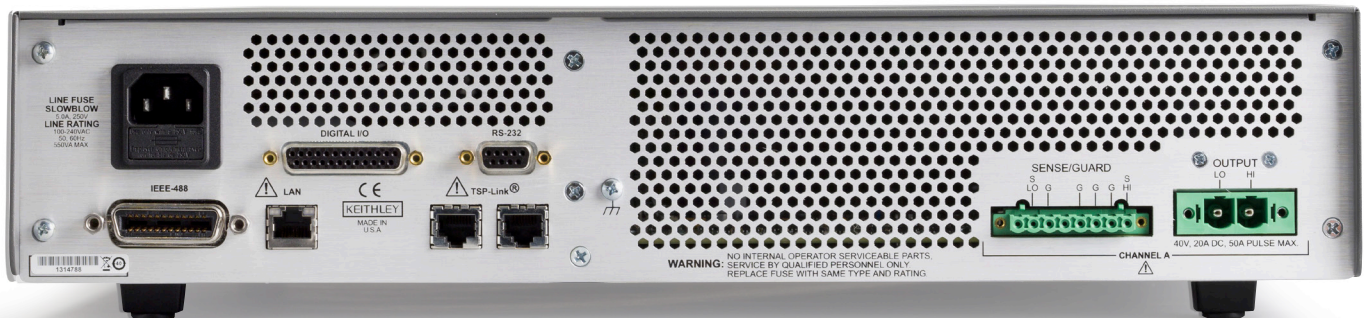

The 2651A supports GPIB, LXI, Digital I/O, and Keithley's TSP-Link Technology for multi-channel synchronization.

Standard Capabilities of Series 2600B SMU Instruments

Each 2651A includes all the features and capabilities provided in most Series 2600B SMU instruments, such as:

- Ability to be used as either a bench-top I-V characterization tool or as a building block component of multiple-channel I-V test systems
- ACS Basic Edition software for semiconductor component characterization (optional). ACS Basic now features a Trace mode for generating a suite of characteristic curves.
- Keithley's Test Script Processor (TSP™) Technology, which enables creation of custom user test scripts to further automate testing, and also supports the creation of programming sequences that allow the instrument to operate asynchronously without direct PC control.
- Parallel test execution and precision timing when multiple SMU instruments are connected together in a system
- LXI compliance
- 14 digital I/O lines for direct interaction with probe stations, component handlers, or other automation tools
- USB port for extra data and test program storage via USB memory device

Instrument Control Start-up Software

KickStart instrument control/start-up software enables users to start making measurements in minutes without programming. In most cases, users merely need to make some quick measurements, graph the data, and store the data to disk for later analysis in software environments such as Microsoft Excel. KickStart offers:

- Configure and control up to four SMU instruments for DC or Pulsed I-V test in either the same app, same project, or a combination of the two.
- Create tests by mixing any of these SMU instruments: 2400 Graphical Series, 2400 Standard Series (DC only), 2600B Series, 2651A, 2657A, and 6430 SourceMeter® SMU (DC only) instruments.
- Differentiate SMU instrument channels and their measurement data using labels that are relevant to your device or module.
- Native X-Y graphing, panning, and zooming; screenshot capturing of graphs.
- Spreadsheet/tabular viewing of data; export data for further analysis.
- Annotating of tests; save test setups.
- GPIB, USB 2.0, Ethernet compliance.



KickStart start-up software lets users be ready to make measurements in minutes.

Specifications

Specification Conditions

This document contains specifications and supplemental information for the 2651A High Power System SourceMeter SMU instrument. Specifications are the standards against which the 2651A is tested. Upon leaving the factory, the 2651A meets these specifications. Supplemental and typical values are non-warranted, apply at 23°C, and are provided solely as useful information.

Accuracy specifications are applicable for both normal and high-capacitance modes.

Source and measurement accuracies are specified at the 2651A terminals under these conditions:

- 18 °C to 28°C, <70 percent relative humidity
- After two-hour warmup
- Speed normal (1 NPLC)
- A/D autozero enabled
- Remote sense operation or properly zeroed local operation
- Calibration period: One year

Voltage Accuracy Specifications^{1,2}

Range	SOURCE			MEASURE		
	Programming Resolution	Accuracy ±(% reading + volts)	Noise (Vpp) (typical) 0.1 Hz to 10 Hz	Default Display Resolution	Integrating ADC Accuracy ³ ±(% reading + volts)	High-Speed ADC Accuracy ⁴ ±(% reading + volts)
100.000 mV	5 µV	0.02% + 500 µV	100 µV	1 µV	0.02% + 300 µV	0.05% + 600 µV
1.00000 V	50 µV	0.02% + 500 µV	500 µV	10 µV	0.02% + 300 µV	0.05% + 600 µV
10.0000 V	500 µV	0.02% + 5 mV	1 mV	100 µV	0.02% + 3 mV	0.05% + 8 mV
20.0000 V	500 µV	0.02% + 5 mV	1 mV	100 µV	0.02% + 5 mV	0.05% + 8 mV
40.0000 V	500 µV	0.02% + 12 mV	2 mV	100 µV	0.02% + 12 mV	0.05% + 15 mV

Current Accuracy Specifications⁵

Range	SOURCE			MEASURE		
	Programming Resolution	Accuracy ±(% reading + amps)	Noise (Ipp) (typical) 0.1 Hz to 10 Hz	Default Display Resolution	Integrating ADC Accuracy ³ ±(% reading + amps)	High-Speed ADC Accuracy ⁴ ±(% reading + amps)
100.000 nA	2 pA	0.1% + 500 pA	50 pA	1 pA	0.08% + 500 pA	0.08% + 800 pA
1.00000 µA	20 pA	0.1% + 2 nA	250 pA	10 pA	0.08% + 2 nA	0.08% + 4 nA
10.0000 µA	200 pA	0.1% + 10 nA	500 pA	100 pA	0.08% + 8 nA	0.08% + 10 nA
100.000 µA	2 nA	0.03% + 60 nA	5 nA	1 nA	0.02% + 25 nA	0.05% + 60 nA
1.00000 mA	20 nA	0.03% + 300 nA	10 nA	10 nA	0.02% + 200 nA	0.05% + 500 nA
10.0000 mA	200 nA	0.03% + 8 µA	500 nA	100 nA	0.02% + 2.5 µA	0.05% + 10 µA
100.000 mA	2 µA	0.03% + 30 µA	1 µA	1 µA	0.02% + 20 µA	0.05% + 50 µA
1.00000 A	200 µA	0.08% + 3.5 mA	300 µA	10 µA	0.05% + 3 mA	0.05% + 5 mA
5.00000 A	200 µA	0.08% + 3.5 mA	300 µA	10 µA	0.05% + 3 mA	0.05% + 5 mA
10.0000 A	500 µA	0.15% + 6 mA	500 µA	100 µA	0.12% + 6 mA	0.12% + 12 mA
20.0000 A	500 µA	0.15% + 8 mA	500 µA	100 µA	0.08% + 8 mA	0.08% + 15 mA
50.0000 A ⁶	2 mA	0.15% + 80 mA	N/A	100 µA	0.05% + 50 mA ⁷	0.05% + 90 mA ⁸

NOTES

1. Add 50 µV to source accuracy specifications per volt of HI lead drop.
2. For temperatures 0° to 18°C and 28° to 50°C, accuracy is degraded by $\pm(0.15 \times \text{accuracy specification})/^\circ\text{C}$. High-capacitance mode accuracy is applicable at 23° ±5°C only.
3. Derate accuracy specification for NPLC setting <1 by increasing error term. Add appropriate typical percent of range term for resistive loads using the table below.

NPLC Setting	100 mV Range	1 V to 40 V Ranges	100 nA Range	1 µA to 100 mA Ranges	1 A to 20 A Ranges
0.1	0.01%	0.01%	0.01%	0.01%	0.01%
0.01	0.08%	0.07%	0.1%	0.05%	0.1%
0.001	0.8%	0.6%	1%	0.5%	1.8%

4. 18-bit ADC. Average of 1000 samples taken at 1 µs intervals.
5. At temperatures 0° to 18°C and 28° to 50°C; 100 nA to 10 µA accuracy is degraded by $\pm(0.35 \times \text{accuracy specification})/^\circ\text{C}$. 100 µA to 50 A accuracy is degraded by $\pm(0.15 \times \text{accuracy specification})/^\circ\text{C}$. High-capacitance mode accuracy is applicable at 23° ±5°C only.
6. 50 A range accessible only in pulse mode.
7. 50 A range accuracy measurements are taken at 0.008 NPLC.
8. Average of 100 samples taken at 1 µs intervals.

DC Power Specifications

Maximum Output Power 202 W maximum.

Source/Sink Limits¹
Voltage: ±10.1 V at ±20.0 A, ±20.2 V at ±10.0 A, ±40.4 V at ±5.0 A². Four-quadrant source or sink operation.
Current: ±5.05 A at ±40 V², ±10.1 A at ±20 V, ±20.2 A at ±10 V. Four-quadrant source or sink operation.

CAUTION: Carefully consider and configure the appropriate output-off state and source and compliance levels before connecting the 2651A to a device that can deliver energy. Failure to consider the output-off state and source and compliance levels may result in damage to the instrument or to the device under test.

Pulse Specifications

Minimum Programmable Pulse Width ³	100 μ s. Note: Minimum pulse width for settled source at a given I/V output and load can be longer than 100 μ s.
Pulse Width Programming Resolution	1 μ s.
Pulse Width Programming Accuracy ³	\pm 5 μ s.
Pulse Width Jitter	2 μ s (typical).

Pulse Rise Time (typical)

Current Range	R _{load}	Rise Time (typical)
50 A	0.05 Ω	26 μ s
50 A	0.2 Ω	57 μ s
50 A	0.4 Ω	85 μ s
20 A	0.5 Ω	95 μ s
50 A	0.8 Ω	130 μ s
20 A	1 Ω	180 μ s
10 A	2 Ω	330 μ s
5 A	8.2 Ω	400 μ s

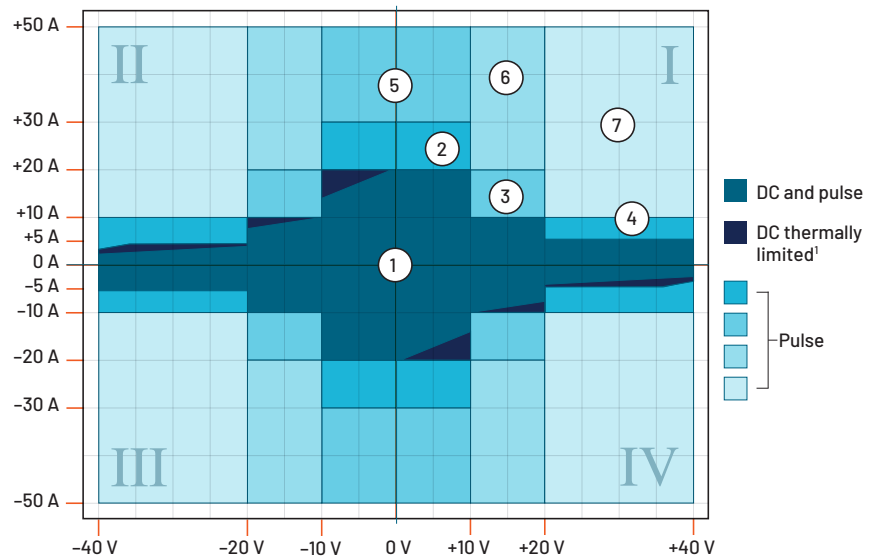

Region	Region Maximums	Maximum Pulse Width ³	Maximum Duty Cycle ⁴
1	5 A at 40 V	DC, no limit	100%
1	10 A at 20 V	DC, no limit	100%
1	20 A at 10 V	DC, no limit	100%
2	30 A at 10 V	1 ms	50%
3	20 A at 20 V	1.5 ms	40%
4	10 A at 40 V	1.5 ms	40%
5	50 A at 10 V	1 ms	35%
6	50 A at 20 V	330 μ s	10%
7	50 A at 40 V	300 μ s	1%

NOTES

- Full power source operation regardless of load to 30°C ambient. Above 30°C or power sink operation, refer to "Operating Boundaries" in the 2651A Reference manual for additional power derating information.
- Quadrants 2 and 4 power envelope is trimmed at 36 V and 4.5 A.
- Times measured from the start of pulse to the start off-time; see figure below.

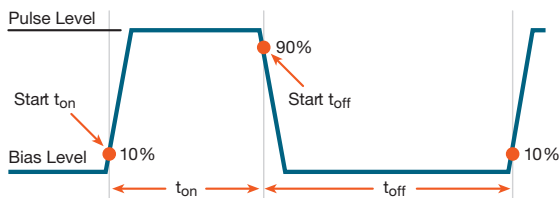

- Thermally limited in sink mode (quadrants 2 and 4) and ambient temperatures above 30°C. See power equations in the 2651A Reference Manual for more information.

Additional Source Specifications

Noise (10 Hz to 20 MHz)	<100 mV peak-peak (typical), <30 mV RMS (typical), 10 V range with a 20 A limit.																																				
Overshoot	Voltage: $\pm(0.1\% + 10 \text{ mV})$ (typical). Step size = 10% to 90% of range, resistive load, maximum current limit/compliance. Current: $\pm(0.1\% + 10 \text{ mV})$ (typical). Step Size = 10% to 90% of range, resistive load. See Current Source Output Settling Time specifications for additional test conditions.																																				
Range Change Overshoot	Voltage: <300 mV + 0.1% of larger range (for <20 V ranges) (typical). <400 mV + 0.1% of larger range (for ≥ 20 V ranges) (typical). Overshoot into a 100 k Ω load, 20 MHz bandwidth. Current: <5% of larger range + 360 mV/R _{load} (for >10 μ A ranges) (typical). $I_{\text{out}} \times R_{\text{load}} = 1 \text{ V}$.																																				
Voltage Source Output Settling Time	Time required to reach within 0.1% of final value after source level command is processed on a fixed range. ¹ <table border="1" data-bbox="451 569 792 726"> <thead> <tr> <th>Range</th> <th>Settling Time (typical)</th> </tr> </thead> <tbody> <tr> <td>1 V</td> <td><70 μs</td> </tr> <tr> <td>10 V</td> <td><160 μs</td> </tr> <tr> <td>20 V</td> <td><190 μs</td> </tr> <tr> <td>40 V</td> <td><175 μs</td> </tr> </tbody> </table>	Range	Settling Time (typical)	1 V	<70 μ s	10 V	<160 μ s	20 V	<190 μ s	40 V	<175 μ s																										
Range	Settling Time (typical)																																				
1 V	<70 μ s																																				
10 V	<160 μ s																																				
20 V	<190 μ s																																				
40 V	<175 μ s																																				
Current Source Output Settling Time	Time required to reach within 0.1% of final value after source level command is processed on a fixed range. Values below for $I_{\text{out}} \times R_{\text{load}}$. <table border="1" data-bbox="451 825 1036 1205"> <thead> <tr> <th>Current Range</th> <th>R_{load}</th> <th>Settling time (typical)</th> </tr> </thead> <tbody> <tr> <td>20 A</td> <td>0.5 Ω</td> <td><195 μs</td> </tr> <tr> <td>10 A</td> <td>1.5 Ω</td> <td><540 μs</td> </tr> <tr> <td>5 A</td> <td>5 Ω</td> <td><560 μs</td> </tr> <tr> <td>1 A</td> <td>1 Ω</td> <td><80 μs</td> </tr> <tr> <td>100 mA</td> <td>10 Ω</td> <td><80 μs</td> </tr> <tr> <td>10 mA</td> <td>100 Ω</td> <td><210 μs</td> </tr> <tr> <td>1 mA</td> <td>1 kΩ</td> <td><300 μs</td> </tr> <tr> <td>100 μA</td> <td>10 kΩ</td> <td><500 μs</td> </tr> <tr> <td>10 μA</td> <td>100 kΩ</td> <td><15 ms</td> </tr> <tr> <td>1 μA</td> <td>1 MΩ</td> <td><35 ms</td> </tr> <tr> <td>100 nA</td> <td>10 MΩ</td> <td><110 ms</td> </tr> </tbody> </table>	Current Range	R _{load}	Settling time (typical)	20 A	0.5 Ω	<195 μ s	10 A	1.5 Ω	<540 μ s	5 A	5 Ω	<560 μ s	1 A	1 Ω	<80 μ s	100 mA	10 Ω	<80 μ s	10 mA	100 Ω	<210 μ s	1 mA	1 k Ω	<300 μ s	100 μ A	10 k Ω	<500 μ s	10 μ A	100 k Ω	<15 ms	1 μ A	1 M Ω	<35 ms	100 nA	10 M Ω	<110 ms
Current Range	R _{load}	Settling time (typical)																																			
20 A	0.5 Ω	<195 μ s																																			
10 A	1.5 Ω	<540 μ s																																			
5 A	5 Ω	<560 μ s																																			
1 A	1 Ω	<80 μ s																																			
100 mA	10 Ω	<80 μ s																																			
10 mA	100 Ω	<210 μ s																																			
1 mA	1 k Ω	<300 μ s																																			
100 μ A	10 k Ω	<500 μ s																																			
10 μ A	100 k Ω	<15 ms																																			
1 μ A	1 M Ω	<35 ms																																			
100 nA	10 M Ω	<110 ms																																			
Transient Response Time	10 V and 20 V Ranges: <70 μ s for the output to recover to within 0.1% for a 10% to 90% step change in load. 40 V Range: <110 μ s for the output to recover to within 0.1% for a 10% to 90% step change in load.																																				
Guard Offset Voltage	<4 mV, current <10 mA.																																				
Remote Sense Operating Range²	Maximum Voltage between HI and SENSE HI: 3 V. Maximum Voltage between LO and SENSE LO: 3 V.																																				
Maximum Impedance per Source Lead	Maximum impedance limited by 3 V drop by remote sense operating range. Maximum resistance = 3 V/source current value (amperes) (maximum of 1 Ω per source lead). $3 \text{ V} = L \text{ di/dt}$.																																				
Voltage Output Headroom	5 A Range: Maximum output voltage = 48.5 V – (Total voltage drop across source leads). 10 A Range: Maximum output voltage = 24.5 V – (Total voltage drop across source leads). 20 A Range: Maximum output voltage = 15.9 V – (Total voltage drop across source leads).																																				
Overtemperature Protection	Internally sensed temperature overload puts unit in standby mode.																																				
Limit/Compliance	Bipolar limit (compliance) set with single value. Voltage³: Minimum value is 10 mV; accuracy is the same as voltage source. Current⁴: Minimum value is 10 nA; accuracy is the same as current source.																																				

NOTES

- With measure and compliance set to the maximum current for the specified voltage range.
- Add 50 μ V to source accuracy specifications per volt of HI lead drop.
- For sink mode operation (quadrants II and IV), add 0.6% of limit range to the corresponding voltage source accuracy specifications. For 100 mV range add an additional 60 mV of uncertainty. Specifications apply with sink mode enabled.
- For sink mode operation (quadrants II and IV), add 0.6% of limit range to the corresponding current limit accuracy specifications. Specifications apply with sink mode enabled.

Additional Measurement Specifications

Contact Check¹

Speed	Maximum Measurement Time to Memory for 60 Hz (50 Hz)	Accuracy (1 Year) 23° ±5°C, ±(% reading + ohms)
Fast	1.1 ms (1.2 ms)	5% + 15 Ω
Medium	4.1 ms (5 ms)	5% + 5 Ω
Slow	36 ms (42 ms)	5% + 3 Ω

NOTES

1. Includes measurement of SENSE HI to HI and SENSE LO to LO contact resistances.

Additional Meter Specifications

Maximum Load Impedance	Normal Mode: 10 nF (typical), 3 μH (typical). High-Capacitance Mode: 50 μF (typical), 3 μH (typical).
Common Mode Voltage	250 V DC.
Common Mode Isolation	>1 GΩ, <4500 pF.
Measure Input Impedance	>10 GΩ.
Sense High Input Impedance	>10 GΩ.
Maximum Sense Lead Resistance	1 kΩ for rated accuracy.
Overrange	101% of source range, 102% of measure range.

High-Capacitance Mode^{1,2}

Accuracy Specifications³ Accuracy specifications are applicable in both normal and high-capacitance modes.

Voltage Source Output Settling Time

Time required to reach within 0.1% of final value after source level command is processed on a fixed range.⁴

Voltage Source Range	Settling Time with C _{load} = 4.7 μF (typical)
1 V	75 μs
10 V	170 μs
20 V	200 μs
40 V	180 μs

Mode Change Delay

100 μA Current Range and Above:

Delay into High-Capacitance Mode: 11 ms. Delay out of High-Capacitance Mode: 11 ms.

1 μA and 10 μA Current Ranges:

Delay into High-Capacitance Mode: 250 ms. Delay out of High-Capacitance Mode: 11 ms.

Measure Input Impedance >10 GΩ in parallel with 25 nF.

Voltage Source Range Change Overshoot

<400 mV + 0.1% of larger range (typical). Overshoot into a 100 kΩ load, 20 MHz bandwidth.

NOTES

- High-capacitance mode specifications are for DC measurements only and use locked ranges. Autorange is disabled.
- 100 nA range is not available in high-capacitance mode.
- Add an additional 2 nA to the source current accuracy and measure current accuracy offset for the 1 μA range.
- With measure and compliance set to the maximum current for the specified voltage range.

Measurement Speed Specifications^{1,2}

Maximum Sweep Operation Rates (Operations per Second) for 60 Hz (50 Hz)

A/D Converter Speed	Trigger Origin	Measure To Memory Using User Scripts	Measure To GPIB Using User Scripts	Source Measure To Memory Using User Scripts	Source Measure To GPIB Using User Scripts	Source Measure To Memory Using Sweep API	Source Measure To GPIB Using Sweep API
0.001 NPLC	Internal	20000(20000)	9800(9800)	7000(7000)	6200(6200)	12000(12000)	5900(5900)
0.001 NPLC	Digital I/O	8100(8100)	7100(7100)	5500(5500)	5100(5100)	11200(11200)	5700(5700)
0.01 NPLC	Internal	4900(4000)	3900(3400)	3400(3000)	3200(2900)	4200(3700)	4000(3500)
0.01 NPLC	Digital I/O	3500(3100)	3400(3000)	3000(2700)	2900(2600)	4150(3650)	3800(3400)
0.1 NPLC	Internal	580(480)	560(470)	550(465)	550(460)	560(470)	545(460)
0.1 NPLC	Digital I/O	550(460)	550(460)	540(450)	540(450)	560(470)	545(460)
1.0 NPLC	Internal	59(49)	59(49)	59(49)	59(49)	59(49)	59(49)
1.0 NPLC	Digital I/O	58(48)	58(49)	59(49)	59(49)	59(49)	59(49)
HS ADC	Internal	38500(38500)	18000(18000)	10000(10000)	9500(9500)	14300(14300)	6300(6300)
HS ADC	Digital I/O	12500(12500)	11500(11500)	7500(7500)	7000(7000)	13200(13200)	6000(6000)

High Speed ADC Burst Measurement Rates³

Burst Length (readings)	Readings per Second	Bursts per Second
100	1,000,000	400
500	1,000,000	80
1000	1,000,000	40
2500	1,000,000	16
5000	1,000,000	8

Maximum Single Measurement Rates (operations per second) for 60 Hz (50 Hz)

A/D Converter Speed	Trigger Origin	Measure To GPIB	Source Measure To GPIB	Source Measure Pass/Fail To GPIB
0.001 NPLC	Internal	1900(1800)	1400(1400)	1400(1400)
0.01 NPLC	Internal	1450(1400)	1200(1100)	1100(1100)
0.1 NPLC	Internal	450(390)	425(370)	425(375)
1.0 NPLC	Internal	58(48)	57(48)	57(48)

Maximum Measurement Range Change Rate

>4000 per second for >10 μ A (typical).

Maximum Source Range Change Rate

>325 per second for >10 μ A, typical. When changing to or from a range \geq 1 A, maximum rate is >250 per second, typical.

Command Processing Time

Maximum time required for the output to begin to change following the receipt of the smua.source.level or smua.source.level1 command. <1 ms typical.

NOTES

1. Tests performed with a 2651A on channel A using the following equipment: Computer hardware (Intel® Pentium® 4 2.4 GHz, 2 GB RAM, National Instruments™ PCI-GPIB). Driver (NI-488.2 Version 2.2 PCI-GPIB). Software (Microsoft® Windows® XP, Microsoft Visual Studio® 2010, VISA™ version 4.1).
2. Exclude current measurement ranges less than 1 mA.
3. smua.measure.adc has to be enabled and the smua.measure.count set to the burst length.

Triggering and Synchronization Specifications

Triggering	Trigger In to Trigger Out: 0.5 μ s (typical). Trigger In to Source Change¹: 10 μ s (typical). Trigger Timer Accuracy: ± 2 μ s (typical). Source Change¹ After LXI Trigger: 280 μ s (typical).
Synchronization	Single-Node Synchronized Source Change¹: <0.5 μ s (typical). Multi-Node Synchronized Source Change¹: <0.5 μ s (typical).

NOTES

1. Fixed source range with no polarity change.

Supplemental Information

Front Panel Interface	Two-line vacuum fluorescent display (VFD) with keypad and navigation wheel.					
Display	<table border="1"> <tr> <td>Show error messages and user defined messages.</td> <td>Display source and limit settings.</td> </tr> <tr> <td>Show current and voltage measurements (6½-digit to 4½-digit).</td> <td>View measurements stored in dedicated reading buffers.</td> </tr> </table>	Show error messages and user defined messages.	Display source and limit settings.	Show current and voltage measurements (6½-digit to 4½-digit).	View measurements stored in dedicated reading buffers.	
Show error messages and user defined messages.	Display source and limit settings.					
Show current and voltage measurements (6½-digit to 4½-digit).	View measurements stored in dedicated reading buffers.					
Keypad Operations	Change host interface settings. Save and restore instrument setups. Load and run factory and user defined test scripts that prompt for input and send results to the display. Store measurements into dedicated reading buffers.					
Programming	Embedded Test Script Processor (TSP®) scripting engine is accessible from any host interface. Responds to individual instrument control commands. Responds to high speed test scripts comprised of instrument control commands and Lua statements (for example, branching, looping, and math). Able to execute high speed test scripts stored in memory without host intervention.					
Minimum User Memory Available	16 MB (approximately 250,000 lines of TSP code).					
TSP Toolkit Software	Visual Studio code extension for building and running TSP scripts. Includes an instrument console for communicating with any TSP enabled instrument in an interactive manner.					
Reading Buffers	Nonvolatile memory uses dedicated storage areas reserved for measurement data. Reading buffers are arrays of measurement elements. Each element can hold the following items: Measurement Source setting (at the time the measurement was taken) Measurement status Timestamp Range information Two reading buffers are reserved for each 2651A channel. Reading buffers can be filled using the front panel STORE key and retrieved using the RECALL key or host interface.					
Buffer Size, with timestamp and source setting	>60,000 samples.					
Buffer Size, without timestamp and source setting	>140,000 samples.					

System Expansion	The TSP-Link® expansion interface allows TSP-enabled instruments to trigger and communicate with each other. Cable type: Category 5e or higher LAN crossover cable. Three meter (9.84 ft) maximum between each TSP-enabled instrument. A maximum of 32 TSP-Link nodes can be interconnected. Each source-measure instrument uses one TSP-Link node.
Timer	Free-running 47-bit counter with 1 MHz clock input. Resets each time instrument power is turned on. If the instrument is not turned off, the timer is reset to zero every 4 years.
Timestamp	TIMER value is automatically saved when each measurement is triggered.
Resolution	1 μ s.
Timestamp Accuracy	\pm 100 ppm.

General

Digital I/O Interface

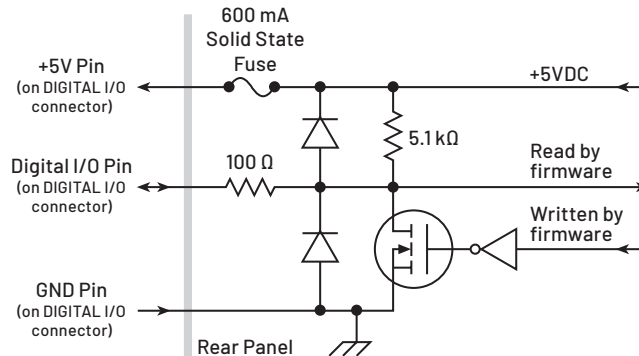

Connector	25-pin female D.
Input/Output Pins	14 open drain I/O bits.
Absolute Maximum Input Voltage	5.25 V.
Absolute Minimum Input Voltage	-0.25 V.
Maximum Logic Low Input Voltage	0.7 V, +850 μ A max.
Minimum Logic High Input Voltage	2.1 V, +570 μ A.
Maximum Source Current (flowing out of digital I/O bit)	+960 μ A.
Maximum Sink Current At Maximum Logic Low Voltage (0.7)	-5.0 mA.
Absolute Maximum Sink Current (flowing into digital I/O pin)	-11 mA.
5 V Power Supply Pin	Limited to 250 mA, solid-state fuse protected.
Output Enable Pin	Active high input pulled down internally to ground with a 10 k Ω resistor; when the output enable input function has been activated, the 2651A channel will not turn on unless the output enable pin is driven to >2.1 V (nominal current = 2.1 V/10 k Ω = 210 μ A).

IEEE-488	IEEE-488.1 compliant. Supports IEEE-488.2 common commands and status topology.
RS-232	Baud rates from 300 bps to 115200 bps. Programmable number of data bits, parity type, and flow control (RTS/CTS hardware or none). When not programmed as the active host interface, the 2651A can use the RS-232 interface to control other instrumentation.
Ethernet	RJ-45 connector, LXI, 10/100BT, Auto MDIX.
LXI Compliance	LXI Class C 1.2.
Total Output Trigger Response Time	245 µs minimum, 280 µs (typical), (not specified) maximum.
Receive Lan[0-7] Event Delay	Unknown.
Generate Lan[0-7] Event Delay	Unknown.
Expansion Interface	The TSP-Link Technology expansion interface allows TSP-enabled instruments to trigger and communicate with each other.
Cable Type	Category 5e or higher LAN crossover cable. 3 meters maximum between each TSP-enabled instrument.
USB	USB 2.0 host controller.
Power Supply	100 V to 250 V AC, 50 Hz to 60 Hz (autosensing), 550 VA maximum.
Cooling	Forced air; side and top intake and rear exhaust.
Warranty	1 year.
EMC	Conforms to European Union EMC Directive.
Safety	UL listed to UL61010-1:2004. Conforms to European Union Low Voltage Directive.
Dimensions	89 mm high × 435 mm wide × 549 mm deep (3.5 in. × 17.1 in. × 21.6 in.).
Bench Configuration (with handle and feet)	104 mm high × 483 mm wide × 620 mm deep (4.1 in. × 19 in. × 24.4 in.).
Weight	9.98 kg (22 lb).
Environment	For indoor, non-residential use only.
Altitude	Maximum 2000 meters above sea level.
Operating	0° to 50°C, 70% relative humidity up to 35°C. Derate 3% relative humidity/°C, 35° to 50°C.
Storage	-25° to 65°C.

Ordering Information

2651A	High Power System SourceMeter® SMU Instrument
-------	---

Supplied Accessories

CS-1592-2	High Current Phoenix Connector (male)
CS-1626-2	High Current Phoenix Connector (female)
CA-557-1	Sense Line Cable Assembly (1 m)
7709-308A	Digital I/O Connector
1746946XX	TSP-Link/Ethernet Cable
	Rack Mount Kit
Documentation	Available at tek.com

Available Accessories

2600-KIT	Screw Terminal Connector Kit
2651A-KIT-3	Low Impedance Cable Assembly (3 m)
ACS-BASICFL	Component Characterization Software
KickStart	Instrument Control Software
8010	High Power Device Test Fixture

Warranty Information

Warranty Summary	This section summarizes the warranties of the 2651A. For complete warranty information, refer to the Tektronix warranty page at www.tek.com/service/warranties/warranty-2 . Any portion of the product that is not manufactured by Keithley is not covered by this warranty and Keithley will have no duty to enforce any other manufacturer's warranties.
Hardware Warranty	Keithley Instruments, Inc. warrants the Keithley manufactured portion of the hardware for a period of one year from defects in materials or workmanship; provided that such defect has not been caused by use of the Keithley hardware which is not in accordance with the hardware instructions. The warranty does not apply upon any modification of Keithley hardware made by the customer or operation of the hardware outside the environmental specifications.
Software Warranty	Keithley warrants for the Keithley produced portion of the software or firmware will conform in all material respects with the published specifications for a period of ninety (90) days; provided the software is used on the product for which it is intended in accordance with the software instructions. Keithley does not warrant that operation of the software will be uninterrupted or error-free, or that the software will be adequate for the customer's intended application. The warranty does not apply upon any modification of the software made by the customer.

Contact Information:

Australia 1 800 709 465
Austria* 00800 2255 4835
Balkans, Israel, South Africa and other ISE Countries +41 52 675 3777
Belgium* 00800 2255 4835
Brazil +55(11) 3530-8901
Canada 1 800 833 9200
Central East Europe / Baltics +41 52 675 3777
Central Europe / Greece +41 52 675 3777
Denmark +45 80 88 1401
Finland +41 52 675 3777
France* 00800 2255 4835
Germany* 00800 2255 4835
Hong Kong 400 820 5835
India 000 800 650 1835
Indonesia 007 803 601 5249
Italy 00800 2255 4835
Japan 81(3) 6714 3086
Luxembourg +41 52 675 3777
Malaysia 1 800 22 55835
Mexico, Central/South America and Caribbean 52 (55) 88 69 35 25
Middle East, Asia, and North Africa +41 52 675 3777
The Netherlands* 00800 2255 4835
New Zealand 0800 800 238
Norway 800 16098
People's Republic of China 400 820 5835
Philippines 1 800 1601 0077
Poland +41 52 675 3777
Portugal 80 08 12370
Republic of Korea +82 2 565 1455
Russia / CIS +7(495) 6647564
Singapore 800 6011 473
South Africa +41 52 675 3777
Spain* 00800 2255 4835
Sweden* 00800 2255 4835
Switzerland* 00800 2255 4835
Taiwan 886 (2) 2656 6688
Thailand 1 800 011 931
United Kingdom / Ireland* 00800 2255 4835
USA 1 800 833 9200
Vietnam 12060128

* European toll-free number. If not accessible, call: +41 52 675 3777

Rev. 02.2022



Find more valuable resources at TEK.COM

Copyright © Tektronix. All rights reserved. Tektronix products are covered by U.S. and foreign patents, issued and pending. Information in this publication supersedes that in all previously published material. Specification and price change privileges reserved. TEKTRONIX and TEK are registered trademarks of Tektronix, Inc. All other trade names referenced are the service marks, trademarks or registered trademarks of their respective companies.

060926 KEI 1KW-73819-1

