

## 6487 Picoammeter/Voltage Source

### DATASHEET



The 5½-digit 6487 Picoammeter/Voltage Source improves on the measurement capability of the award-winning 6485, and adds a high resolution 500 V source. It provides higher accuracy and faster rise times than the 6485, as well as a damping function for use with capacitive devices. With eight current measurement ranges and high speed autoranging, this cost-effective instrument can measure currents from 20 fA to 20 mA, take measurements at speeds up to 1000 readings per second, and source voltage from 200 µV to 505 V.

The 6487's 10 fA resolution, superior sensitivity, voltage sweeping, and Alternating Voltage resistance measurements make it well suited for characterizing low current devices. Using the latest current measurement technology, it is significantly less expensive than other instruments that perform similar functions, such as optical power meters, tera-ohmmeters, competitive picoammeters, or user-designed solutions. With a price that's comparable to a high-end DMM, the 6487 makes picoamp-level measurements affordable for virtually any laboratory or production floor.

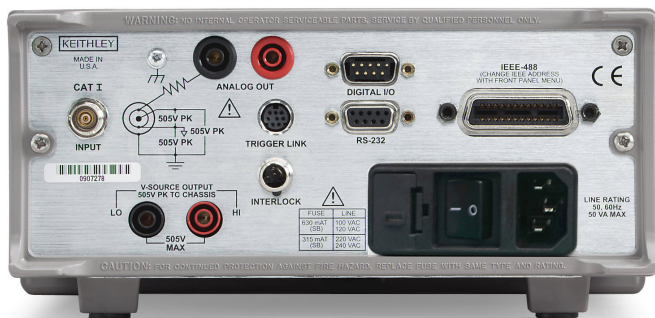

### Key Features

- 10 fA resolution
- 5½-digit resolution
- <200 µV burden voltage
- Alternating Voltage method ohms measurements
- Automated voltage sweeps for I-V characterization
- Floating measurements up to 500 V
- Up to 1000 readings/second
- Built-in 486 and 487 emulation mode
- IEEE-488 and RS-232 interfaces
- Analog output
- Digital I/O

### Low Voltage Burden and Higher Accuracy

While DMMs typically employ shunt ammeter circuitry to measure current, the 6487 is a feedback picoammeter. This design reduces voltage burden by several orders of magnitude, resulting in a voltage burden of less than 200 µV on the lower measurement ranges. The low voltage burden makes the 6487 function much more like an ideal ammeter than a DMM, so it can make current measurements with high accuracy, even in circuits with very low source voltages.

### Successor to the 487

The 6487 builds on the strengths of one of Keithley's most popular picoammeters, the 487, offering an additional 20 mA measurement range, as well as much higher measurement speeds, up to 1000 readings per second. It simplifies device characterization with built-in voltage sweeping capability and the Alternating Voltage method for high resistances. A time-stamped 3000-reading data buffer provides minimum, maximum, and standard deviation statistics. A built-in emulation mode makes it possible to control the 6487 with any custom code written to control the 487.

	487	6487
Current Ranges	2 nA to 2 mA	2 nA to 20 mA
Voltage Burden	200 $\mu$ V	200 $\mu$ V (1 mV on 20 mA range)
Reading Rate	Up to 180/s	Up to 1000/s
Voltage Sweeps	No	Yes
Alternating Voltage Ohms	No	Yes
Analog Output	Yes (non-inverting)	Yes (inverting)
Storage Buffer	512 points	3000 points
Best V Source Resolution	1 mV	0.2 mV

### When do you need a picoammeter?

Measuring low DC currents often demands a lot more than a digital multimeter can deliver. Generally, DMMs lack the sensitivity required to measure currents less than 100 nA. Even at higher currents, a DMM's input voltage drop (voltage burden) of hundreds of millivolts can make accurate current measurements impossible. Electrometers can measure low currents very accurately, but the circuitry needed to measure extremely low currents, combined with functions like voltage, resistance, and charge measurement, can increase an electrometer's cost significantly. The 6487 Picoammeter/Voltage Source combines the economy and ease of use of a DMM with low current sensitivity near that of an electrometer.

### Applications

- Resistance/resistivity measurements
- Beam monitoring and radiation monitoring
- Leakage current testing in insulators, switches, relays, and other components
- Galvanic coupling measurements
- I-V characterization on semiconductor and optoelectronic devices
- Fiber alignment
- Circuit test and analysis in DCLF circuits
- Sensor characterization
- Capacitor leakage

## Features that Expand Test and Measurement Flexibility

- **Direct resistance measurements.** Optimized for resistances from 50  $\Omega$  to  $5 \times 10^{14}$   $\Omega$  using the Source Voltage/Measure Current method.
- **Alternating Voltage method resistance measurements.** This method improves resistance measurements on devices with high background current or high noise. It extends the measurable resistance range up to  $10^{16}$   $\Omega$ .
- **500 V overload protection.** This high overload protection and a robust design let the 6487 tolerate abusive overflows, including accidentally shorting the voltage source directly into the ammeter.
- **Rear panel triax input.** This allows the picoammeter to be used in floating operation, up to 500 V. When not floating, the addition of a triax to BNC adapter allows inexpensive, easy-to-use BNC cables to be employed, rather than more expensive triaxial cables.
- **RS-232 and IEEE-488 interfaces.** These interfaces make it easy to integrate the 6487 into automated test and measurement systems.
- **Scaled voltage analog output.** This output allows the 6487 to transmit measurement results to devices like DMMs, data acquisition cards, oscilloscopes, or strip chart recorders.
- **Built-in Trigger Link interface.** The Trigger Link interface simplifies synchronizing the 6487 with other instruments and voltage sources. This interface combines six independent selectable trigger lines on a single connector for simple, direct control over all instruments in a system.
- **Display on/off switch.** For research on light-sensitive components, such as measuring the dark currents of photodiodes or I-V measurements on unpackaged semiconductors, the front panel display can be switched off to avoid introducing light that could significantly reduce the accuracy of the results.
- **One-touch front panel design.** Functions can be configured easily with the push of a button, without complicated function menus.
- **KickStart Software.** Start measuring in minutes with this instrument control software. Graph and store data for later analysis in software environments like Excel.

## A Broad Range of Low Current Applications

### Wafer-Level Photodiode Testing

The 6487 Picoammeter/Voltage Source can be paired with a calibrated light source and a probing fixture to create a cost-effective photodiode test system. Multiple 6487s can be connected to the DUT's probe pads to provide photocurrent readings or, with the addition of a switch matrix, one picoammeter can take current measurements from multiple pads. In the first step of the measurement process, performed in total darkness, the 6487 produces a voltage sweep and then measures the resulting dark current. In the second step, a voltage bias is applied and the resulting photocurrent is measured while the light level is increased in calibrated steps. The same basic test configuration can be used for testing positive intrinsic negative (PIN) and avalanche photodiodes (APDs). The 6487's high resolution on the 10 V source range provides superior sweeping and biasing when small biases are required. The 500 V source capability is necessary to bias APDs.

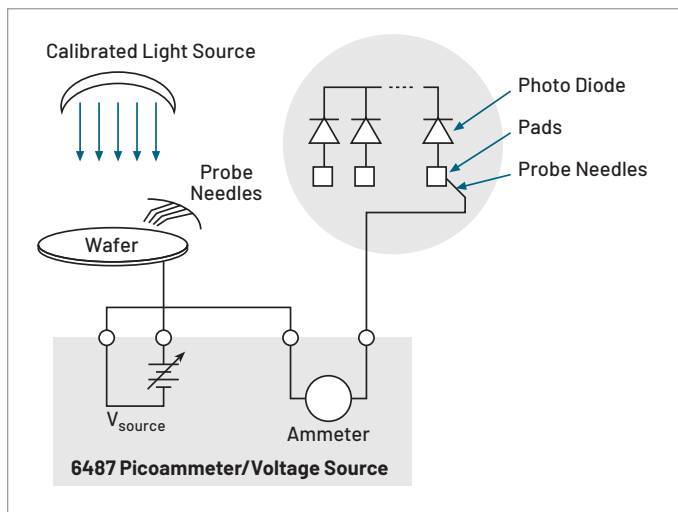

### Monitoring and Control of Focused Ion Beam Currents

In semiconductor fabrication, focused ion beam systems are often used for nanometer-scale imaging, micromachining, and mapping. Careful monitoring of the magnitude of the beam current with an ion detector is critical. The ion detector generates a secondary current that's proportional to the current of the primary ion beam. When this secondary current is measured, it can be used to control the intensity of the primary beam. However, this secondary current is very low, often just a few picoamps, so the instrumentation

measuring it must provide high measurement accuracy and repeatability, as well as sub-picoamp resolution. The 6487's wide measurement range and  $5\frac{1}{2}$ -digit resolution make it ideal for this application. Signal connections to the 6487 are made through the instrument's triax connector. Often, a detector may require high voltage to attract ions, making the 6487's 500 V source a necessity.

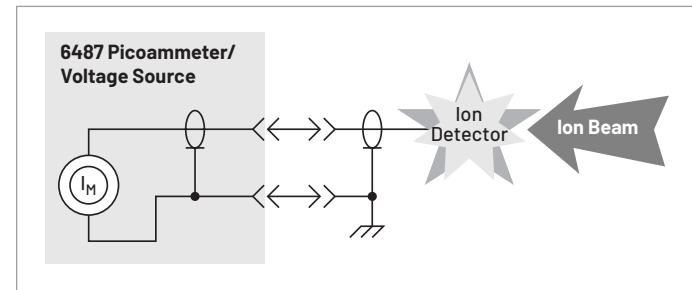

### High Resistance Measurements

The 6487 Picoammeter can be used to measure high resistances ( $>1\text{ G}\Omega$ ) in applications such as insulation resistance testing. A constant voltage is placed in series with the unknown resistance and the picoammeter. The voltage drop across the picoammeter is negligible, so all the voltage appears across the unknown resistance. The resulting current is measured by the picoammeter and the resistance is calculated using Ohm's Law ( $R = V/I$ ). To prevent generated current due to electrostatic interference, the unknown resistance is housed in a shielded test fixture. A small series resistor may be added to reduce noise if the unknown resistor has high stray capacitance across it.

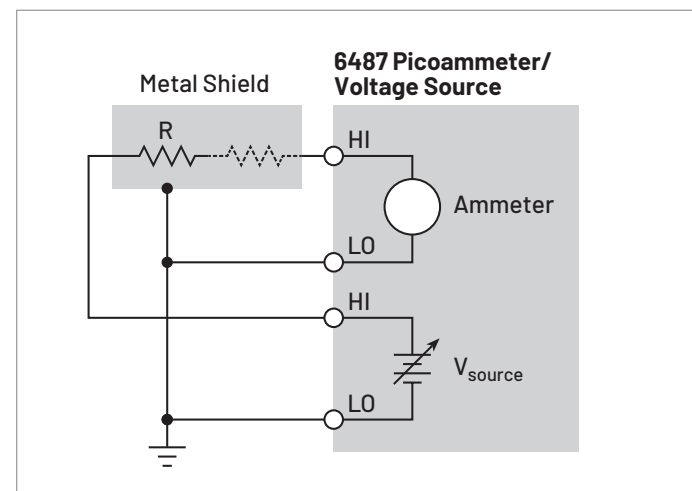

## Specifications

### Current

Range	5½ Digit Default Resolution	Accuracy (1 Year) <sup>1</sup> ±(% rdg. + offset) 18°-28°C, 0-70% RH	Typical RMS Noise <sup>2</sup>	Typical Analog Rise Time (10% to 90%) <sup>3</sup> Damping <sup>4</sup>	
				Off	On
2 nA	10 fA	0.3% + 400 fA	20 fA	4 ms	80 ms
20 nA	100 fA	0.2% + 1 pA	20 fA	4 ms	80 ms
200 nA	1 pA	0.15% + 10 pA	1 pA	300 μs	1 ms
2 μA	10 pA	0.15% + 100 pA	1 pA	300 μs	1 ms
20 μA	100 pA	0.1% + 1 nA	100 pA	110 μs	110 μs
200 μA	1 nA	0.1% + 10 nA	100 pA	110 μs	110 μs
2 mA	10 nA	0.1% + 100 nA	10 nA	110 μs	110 μs
20 mA	100 nA	0.1% + 1 μA	10 nA	110 μs	110 μs

**Temperature Coefficient** 0°C to 18°C & 28°C to 50°C. For each °C, add 0.1 × (% reading + offset) to accuracy spec.

**Input Voltage Burden** <200 μV on all ranges except <1 mV on 20 mA range.

**Maximum Input Capacitance** Stable to 10 nF on all nA ranges and 2 μA range; 1 μF on 20 μA and 200 μA ranges, and on mA ranges.

**Maximum Continuous Input Voltage** 505 VDC.

**NMRR<sup>1</sup> (50 or 60 Hz)** 60 dB.

**Isolation (Ammeter Common or Voltage Source to chassis)**  
Typically >1×10<sup>11</sup> Ω in parallel with <1 nF.

**Maximum Common Mode Voltage (between chassis and voltage source or ammeter)**  
505 VDC.

**Analog Output** Scaled voltage output (inverting 2 V full scale on all ranges): 2.5% ±2 mV.

**Analog Output Impedance<sup>5</sup>** <100 Ω, DC-2 kHz.

### Voltage Source

Range (Maximum)	Step Size (typical)	Accuracy <sup>5</sup> ±(% prog. + offset) 18°-28°C, 0-70% R.H.	Noise (p-p) 0.1-10 Hz	Temperature Coefficient	Typical Rise Time <sup>6,8</sup> (10%-90%)	Typical Fall Time <sup>7,8</sup> (90%-10%)
±10.100	200 μV	0.1% + 1 mV	<50 μV	(0.005% + 20 μV)/°C	250 μs	150 μs
±50.500	1 mV	0.1% + 4 mV	<150 μV	(0.005% + 200 μV)/°C	250 μs	300 μs
±505.00	10 mV	0.15% + 40 mV	<1.5 mV	(0.008% + 2 mV)/°C	4.5 ms	1 ms

### NOTES

- At 1 PLC - limited to 60 rdgs/s under this condition.
- At 6 PLC, 1 standard deviation, 100 readings, filter off, capped input - limited to 10 rdgs/s under this condition.
- Measured at analog output with resistive load >2 kΩ.
- Maximum rise time can be up to 25% greater.
- Accuracy does not include output resistance/load regulation.
- Rise Time is from 0 V to ± full-scale voltage (increasing magnitude).
- Fall Time is from ± full-scale voltage to 0 V (decreasing magnitude).
- For capacitive loads, add C·ΔV/ILimit to rise time, and C·ΔV/1 mA to fall time.

**Selectable Current Limit** 2.5 mA, 250 μA, 25 μA for 50 V and 500 V ranges, 25 mA additional limit for 10 V range. All current limits are -20%/+35% of nominal.

**Wideband Noise** <30 mV p-p 0.1 Hz-20 MHz. Measured with LO connected to chassis ground.

**Typical Time Stability** ±(0.003% + 1 mV) over 24 hours at constant temperature (within 1°C, between 18°C to 28°C, after 5 minute settling).

**Output Resistance** <2.5 Ω.

**Voltage Sweeps** Supports linear voltage sweeps on fixed source range, one current or resistance measurement per step. Maximum sweep rate: 200 steps per second. Maximum step count 3000. Optional delay between step and measure.

<b>Resistance Measurement (V/I)</b>	Used with voltage source; resistance calculated from voltage setting and measured current. Accuracy is based on voltage source accuracy plus ammeter accuracy. Typical accuracy better than 0.6% for readings between 1 k $\Omega$ and 1 T $\Omega$ .
-------------------------------------	---

<b>Alternating Voltage Resistance Measurement</b>	Offers alternating voltage resistance measurements for resistances from 10 <sup>9</sup> $\Omega$ to 10 <sup>15</sup> $\Omega$ . Alternates between 0 V and user-selectable voltage up to $\pm 505$ V.
---	---

## Remote Operation

<b>IEEE-488 Bus Implementation</b>	SCPI (IEEE-488.2, SCPI-1996.0); DDC (IEEE-488.1).
<b>Language Emulation</b>	Keithley 486/487 emulation via DDC mode.
<b>RS-232 Implementation</b>	<b>Supports:</b> SCPI 1996.0. <b>Baud Rates:</b> 300, 600, 1200, 2400, 4800, 9600, 19.2k, 38.4k, 57.6k. <b>Protocols:</b> Xon/Xoff, 7 or 8 bit ASCII, parity-odd/even/none. <b>Connector:</b> DB-9 TXD/RXD/GND.

## General

<b>Ammeter Input Connector</b>	Three lug triaxial on rear panel.
<b>Analog Output Connector</b>	Two banana jacks on rear panel.
<b>Voltage Source Output Connector</b>	Two banana jacks on rear panel.
<b>Interlock Connector</b>	4 pin DIN.
<b>Trigger Line</b>	Available, see manual for usage.
<b>Display</b>	12 character vacuum fluorescent.
<b>Digital Filter</b>	Median and averaging (selectable from 2 to 100 readings).
<b>Ranging</b>	Automatic or manual.
<b>Autoranging Time</b>	<250 ms (analog filter off, 1 PLC). Measured from trigger in to meter complete.
<b>Overrange Indication</b>	Display reads "OVRFLOW."
<b>Conversion Time</b>	Selectable 0.01 PLC to 60 PLC; 50 PLC under 50 Hz operation. (Adjustable from 200 $\mu$ s to 1 s.)
<b>Reading Rate</b>	<b>To internal buffer:</b> 1000 readings/second (0.01 PLC, digital filters off, front panel off, auto zero off). <b>To IEEE-488 bus:</b> 900 readings/second. (0.01 PLC, digital filters off, front panel off, auto zero off; binary transfer mode. IEEE-488.1).
<b>Buffer</b>	Stores up to 3000 readings.
<b>Programs</b>	Provide front panel access to IEEE address, choice of engineering units or scientific notation, and digital calibration.
<b>EMC</b>	Conforms with European Union Directive.
<b>Safety</b>	Conforms with European Union Low Voltage Directive.
<b>RoHS</b>	Conforms with European Union RoHS Directive.
<b>Environment</b>	For indoor, non-residential use only <b>Operating:</b> 0° to 50°C; relative humidity 70% non-condensing, up to 35°C. Above 35°C, derate humidity by 3% for each °C. <b>Storage:</b> -10°C to +65°C.
<b>Warm-Up</b>	1 hour to rated accuracy (see manual for recommended procedure).
<b>Power</b>	100 V to 120 V or 220 V to 240 V, 50 Hz to 60 Hz, (50 VA).
<b>Physical</b>	<b>Case Dimensions:</b> 90 mm high $\times$ 214 mm wide $\times$ 369 mm deep (3½ in. $\times$ 8⅜ in. $\times$ 14⅞ in.). <b>Working Dimensions:</b> From front of case to rear including power cord and IEEE-488 connector 394 mm (15.5 inches).
<b>Net Weight</b>	<4.7 kg (<10.3 lbs).

## Ordering Information

<b>6487</b>	Picoammeter/Voltage Source
-------------	----------------------------

## Supplied Accessories

<b>CAP-31</b>	Protective Shield/Cap (3-lug)
<b>CS-459</b>	Safety Interlock Plug

## Available Accessories

### Cables

<b>7007-1</b>	Shielded IEEE-488 Cable, 1 m (3.3 ft)
<b>7078-TRX-10</b>	Low Noise Triax Cable, 3.0 m (10 ft)
<b>7078-TRX-20</b>	Low Noise Triax Cable, 6.0 m (20 ft)
<b>8501-1</b>	Trigger Link Cable with male Micro-DIN connectors at each end, 1 m (3.3 ft)

### Adapters

<b>237-TRX-BAR</b>	Triax Barrel
<b>7078-TRX-BNC</b>	Triax-to-BNC Adapter

### Test Fixtures

<b>8009</b>	Resistivity Test Fixture
-------------	--------------------------

### Rack Mount Kits

<b>4288-1</b>	Single Fixed Rack Mounting Kit
<b>4288-2</b>	Dual Fixed Rack Mounting Kit

### GPIB Interfaces

<b>KPCI-488LPA</b>	IEEE-488 Interface/Controller for the PCI Bus
<b>KUSB-488B</b>	IEEE-488 USB-to-GPIB Interface Adapter

## Software Options

<b>KickStart</b>	Instrument Control Software
------------------	-----------------------------

## Available Services

<b>6487-3Y-EW</b>	1-year factory warranty extended to 3 years from date of shipment
<b>C/6487-3Y-ISO</b>	3 (ISO-17025 accredited) calibrations within 3 years of purchase*

\*Not available in all countries

## Warranty Information

---

<b>Warranty Summary</b>	This section summarizes the warranties of the 6487. For complete warranty information, refer to the 6487 Reference Manual. Any portion of the product that is not manufactured by Keithley is not covered by this warranty and Keithley will have no duty to enforce any other manufacturer's warranties.
<b>Hardware Warranty</b>	Keithley Instruments, Inc. warrants the Keithley manufactured portion of the hardware for a period of one year from defects in materials or workmanship; provided that such defect has not been caused by use of the Keithley hardware which is not in accordance with the hardware instructions. The warranty does not apply upon any modification of Keithley hardware made by the customer or operation of the hardware outside the environmental specifications.
<b>Software Warranty</b>	Keithley warrants for the Keithley produced portion of the software or firmware will conform in all material respects with the published specifications for a period of ninety (90) days; provided the software is used on the product for which it is intended in accordance with the software instructions. Keithley does not warrant that operation of the software will be uninterrupted or error-free, or that the software will be adequate for the customer's intended application. The warranty does not apply upon any modification of the software made by the customer.

## Contact Information:

**Australia** 1 800 709 465  
**Austria\*** 00800 2255 4835  
**Balkans, Israel, South Africa and other ISE Countries** +41 52 675 3777  
**Belgium\*** 00800 2255 4835  
**Brazil** +55 (11) 3530-8901  
**Canada** 1 800 833 9200  
**Central East Europe / Baltics** +41 52 675 3777  
**Central Europe / Greece** +41 52 675 3777  
**Denmark** +45 80 88 1401  
**Finland** +41 52 675 3777  
**France\*** 00800 2255 4835  
**Germany\*** 00800 2255 4835  
**Hong Kong** 400 820 5835  
**India** 000 800 650 1835  
**Indonesia** 007 803 601 5249  
**Italy** 00800 2255 4835  
**Japan** 81 (3) 6714 3086  
**Luxembourg** +41 52 675 3777  
**Malaysia** 1 800 22 55835  
**Mexico, Central/South America and Caribbean** 52 (55) 88 69 35 25  
**Middle East, Asia, and North Africa** +41 52 675 3777  
**The Netherlands\*** 00800 2255 4835  
**New Zealand** 0800 800 238  
**Norway** 800 16098  
**People's Republic of China** 400 820 5835  
**Philippines** 1 800 1601 0077  
**Poland** +41 52 675 3777  
**Portugal** 80 08 12370  
**Republic of Korea** +82 2 565 1455  
**Russia / CIS** +7 (495) 6647564  
**Singapore** 800 6011 473  
**South Africa** +41 52 675 3777  
**Spain\*** 00800 2255 4835  
**Sweden\*** 00800 2255 4835  
**Switzerland\*** 00800 2255 4835  
**Taiwan** 886 (2) 2656 6688  
**Thailand** 1 800 011 931  
**United Kingdom / Ireland\*** 00800 2255 4835  
**USA** 1 800 833 9200  
**Vietnam** 12060128

\* European toll-free number. If not accessible, call: +41 52 675 3777

Rev. 02.2022

Find more valuable resources at [TEK.COM](https://www.tek.com)

Copyright © Tektronix. All rights reserved. Tektronix products are covered by U.S. and foreign patents, issued and pending. Information in this publication supersedes that in all previously published material. Specification and price change privileges reserved. TEKTRONIX and TEK are registered trademarks of Tektronix, Inc. All other trade names referenced are the service marks, trademarks or registered trademarks of their respective companies.

060426 KEI 1KW-73905-2

