

# 6517B Electrometer/High Resistance Meter

## DATASHEET



The Keithley 6517B Electrometer/High Resistance Meter is the worldwide research laboratory standard for sensitive measurements. With over 60 years of low level measurement expertise, Keithley electrometers provide reliable measurements of current levels down to 10 aA ( $10 \times 10^{-18}$  A), charge levels down to 1 fC, and the highest resistance measurements available up to  $10^{18}$  Ω. The 6517B is also capable of measuring the largest voltage range—up to 200 V—with an input impedance exceeding 200 TΩ. All this performance is built into an instrument that operates as simply as a digital multimeter.

## Exceptional Performance Specifications

The 6517B has incorporated Keithley's decades of expertise in low level measurement technology into an innovative, low current input amplifier with an input bias current of <3 fA, just 0.75 fA p-p noise, and <20 μV burden voltage on the lowest current ranges. The voltage circuit input impedance is greater than 200 TΩ for near-ideal circuit loading. These specifications ensure the accuracy and sensitivity needed for accurate low current and high impedance voltage, resistance, and charge measurements in areas of research such as physics, optics, nanotechnology, and materials science. A built-in ±1 kV voltage source with sweep capability simplifies performing leakage, breakdown, and resistance testing, as well as volume (Ω-cm) and surface resistivity (Ω/square) measurements on insulating materials.

## Key Features

- Measures resistances up to  $10^{18}$  Ω
- 10 aA ( $10 \times 10^{-18}$  A) current measurement resolution
- Complete hardware-software solution for ASTM D257 high resistivity measurements with the 6517B, 8009 Resistivity Test Fixture, and the KickStart High Resistivity Application
- <3 fA input bias current
- 6½-digit high accuracy measurement mode
- <20 μV burden voltage on the lowest current ranges
- Voltage measurements up to 200 V with >200 TΩ input impedance
- Built-in ±1000 V voltage source
- Unique alternating polarity voltage sourcing and measurement method for high resistance measurements
- Built-in test sequences for four different device characterization tests, surface and volume resistivity, surface insulation resistance, and voltage sweeping
- Optional plug-in scanner cards for testing up to ten devices or material samples with one test setup
- GPIB and RS-232 interfaces

## Wide Measurement Ranges

The 6517B offers autoranging over the full span of ranges on current, resistance, voltage, and charge measurements. The 6517B combines the following measurement capabilities:

- Ultra-sensitive ammeter with current measurement from 10 aA to 20 mA
- Highest impedance voltmeter with voltage measurement from 1 μV to 200 V
- Ultra-high range ohmmeter with resistance measurement from 1 Ω to  $10^{18}$  Ω
- Sensitive coulombmeter with charge measurement from 1 fC to 2 μC

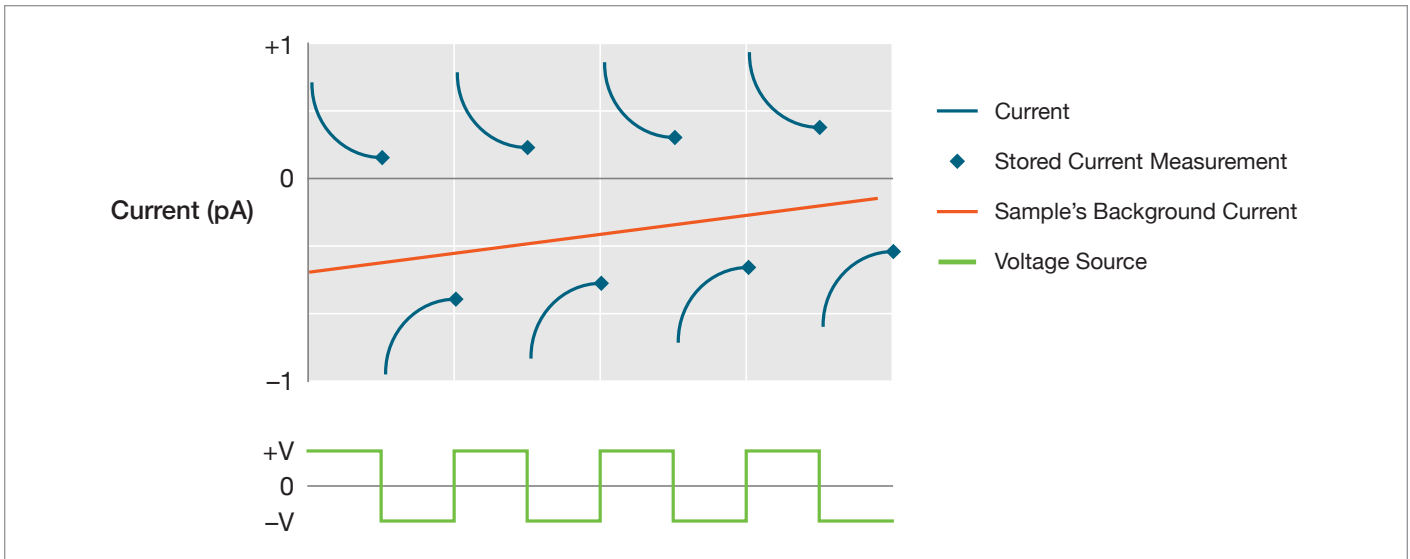

The alternating voltage source polarity method eliminates the effects of background currents in materials for making repeatable, accurate high resistance and resistivity measurements.

## Improved High Resistivity Measurements

Many test applications require measuring high levels of resistivity (surface or volume) of materials. The conventional method of making these measurements is to apply a sufficiently large voltage to a sample, measure the current that flows through the sample, then calculate the resistance using Ohm's Law ( $R=V/I$ ). While high resistance materials and devices produce very small currents that are difficult to measure accurately, Keithley electrometers and picoammeters are used successfully for such measurements.

Even with high quality instrumentation, inherent background currents in the material can make these measurements difficult to perform accurately. Insulating materials, polymers, and plastics typically exhibit background currents due to piezoelectric effects, capacitive elements charged by static electricity, and polarization effects. These background currents are often equal to or greater than the current stimulated by the applied voltage. In these cases, the result is often unstable, providing inaccurate resistance or resistivity readings or even erroneous negative values. Keithley's 6517B is designed to solve these problems and provides

consistent, repeatable, and accurate measurements for a wide variety of materials and components, especially when used in combination with the 8009 Resistivity Test Fixture.

## Alternating Polarity Method for High Resistivity Measurements

The 6517B uses the Alternating Polarity Method, which virtually eliminates the effect of any background currents in the sample. First and second order drifts of the background currents are also canceled out. The Alternating Polarity Method applies a voltage of positive polarity, then the current is measured after a specified delay (Measure Time). Next, the polarity is reversed and the current measured again, using the same delay. This process is repeated continuously, and the resistance is calculated based on a weighted average of the four most recent current measurements. This method typically produces a highly repeatable, accurate measurement of resistance (or resistivity) by the seventh reversal on most materials (i.e., by discarding the first three readings). For example, a 1 mm-thick sample of  $10^{14}$   $\Omega$ -cm material can be measured with 0.3% repeatability in the 8009 Resistivity Test Fixture, provided the background current changes less than 200 fA over a 15-second period.

## Built-In Source Enhances Accuracy of High Resistance Measurements

The 6517B offers a number of features and capabilities that help ensure the accuracy of high resistance measurement applications. For example, the built-in voltage source simplifies determining the relationship between an insulator's resistivity and the level of source voltage used. It is well-suited for capacitor leakage and insulation resistance measurements, tests of the surface insulation resistance of printed circuit boards, voltage coefficient testing of resistors, and diode leakage characterization.

## Complete High Resistivity Measurement Solution

Perform high resistivity measurements using test methods defined by the standard, ASTM D-257, "DC Resistance or Conductance of Insulating Materials", with the following package:

- KICKSTARTFL-HRMA2 High Resistivity Application for the KickStart Instrument Software Control environment
- 6517B Electrometer
- 8009 Resistivity Test Fixture

The KickStart High Resistivity Application controls the electrometer and the test fixture to perform all the measurements needed to make ASTM- D-257 standard resistivity measurements. Test materials at

voltages up to 1000 V. Determine resistivity up to  $10^{18}$   $\Omega$ -cm. Analyze step response plots of current vs time to determine how long to wait for a measurement to settle on the material-under-test. Analyze a plot of multiple readings to ensure that settled and consistent measurements are being taken. The KickStart High Resistance Application uses the alternating polarity technique to eliminate inherent background currents for the most accurate resistivity measurements. Also use the application to observe resistivity dependency on temperature and relative humidity using the optional thermocouple and relative humidity probes.

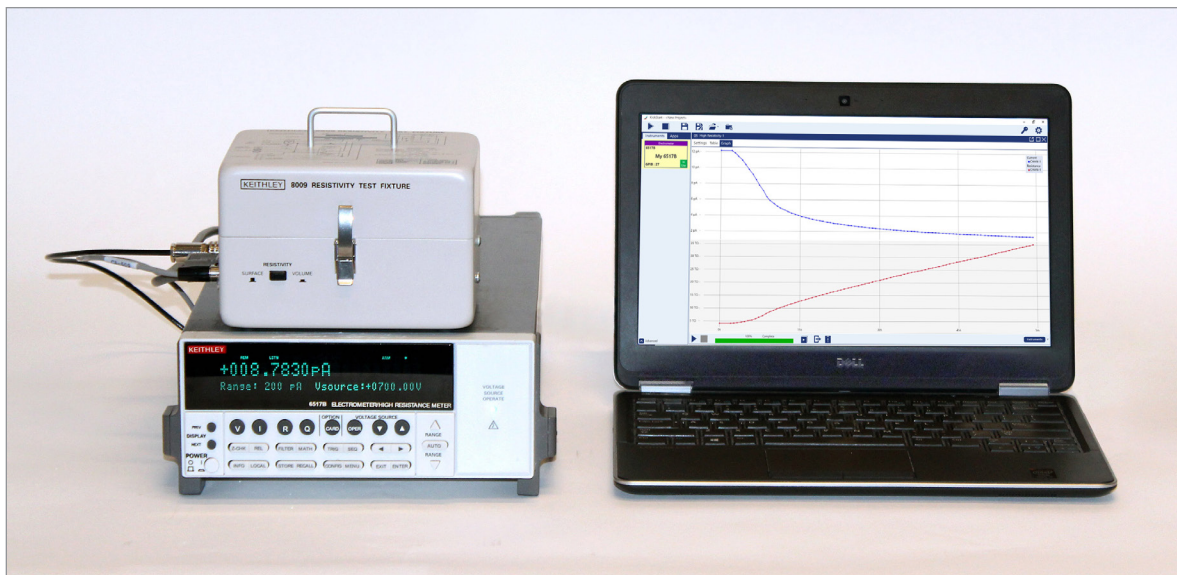

ASTM-D257-compliant High Resistivity Test System with the 6517B Electrometer, 8009 Resistivity Test Fixture, and the KickStart High Resistivity Application.

Measurement Type: Volume Resistivity

Measurement Mode: Step Response

Use ASTM D257 Procedure:

Test Voltage: 500 V

Test Time: 60 s

Current Range: Auto

NPLC: 1

Measure Temperature:

Measure Humidity:

Use 8009 Test Fixture Geometries:

Electrode Area: 20.97 cm<sup>2</sup>

Material Thickness: 1 mm

Meter Connect:

Discharge Device: Sources 0V for 4x Test Time

Auto Discharge:

Volume Resistivity: 19.4 PΩ-cm

KickStart High Resistivity step response plot

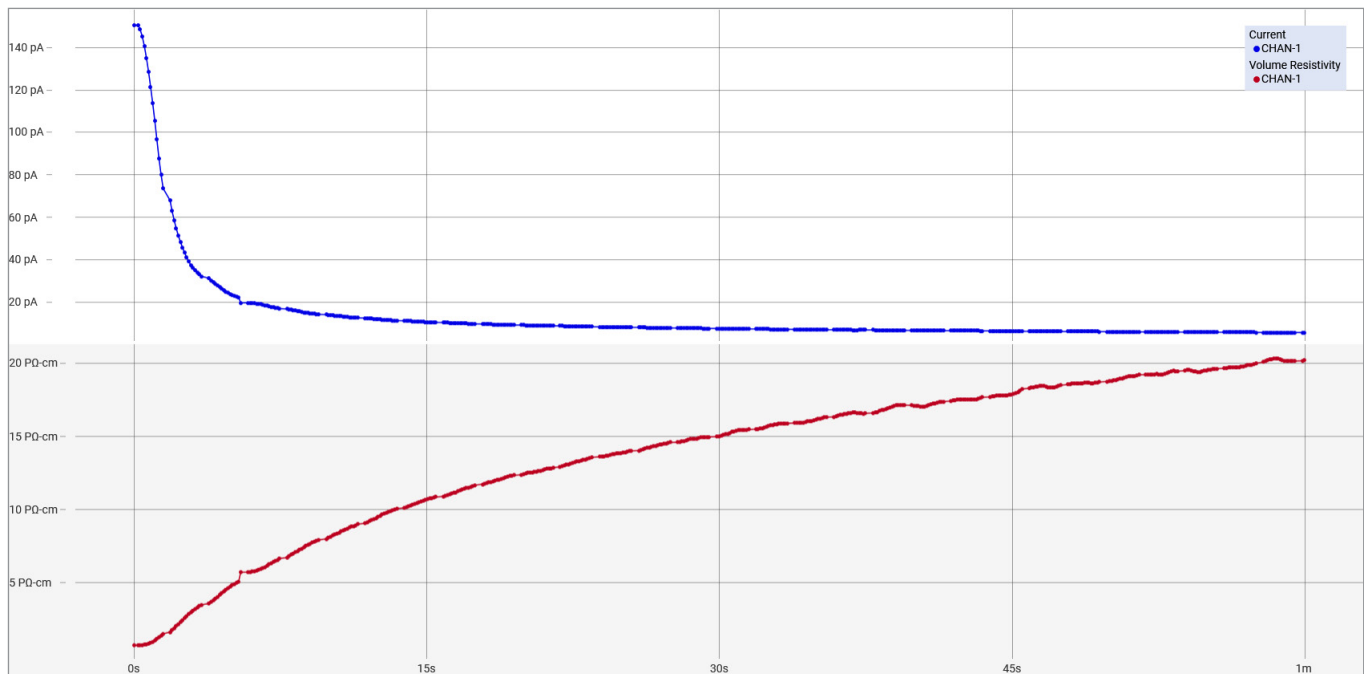

KickStart High Resistivity resistivity plot

## Internal Test Sequences Expand and Simplify Applications

The 6517B has a number of internal test sequences that assists in easily setting up and performing a number of tests. Device characterization sequences include diode leakage current measurement, capacitor leakage current measurement, cable insulation resistance measurement, and resistor voltage coefficient measurement. Resistivity and resistance tests include volume resistivity, surface resistivity, and surface insulation resistance testing. Parameters can be characterized as a function of voltage with the square wave and staircase test sequences.

In addition to its built-in tests, the 6517B excels in low current, high impedance voltage, resistance, and charge measurements in areas of research such as physics, optics, and materials science. The electrometer's extremely low voltage burden makes it particularly valuable for use in solar cell characterization applications and its built-in voltage source and low current sensitivity make it an excellent solution for high resistance measurements of nanomaterials such as polymer-based nanowires, other nanomaterials, ceramics, dielectric films, and biomaterials.

With its highly responsive measurements and DMM-like operation, the 6517B performs well in quality control, design engineering, and production test applications involving leakage current, breakdown, and resistance testing. Volume and surface resistivity measurements on non-conductive materials are particularly enhanced by the 6517B's voltage reversal method. The 6517B is also excellent for electrochemistry applications such as high impedance, ion-selective electrodes and pH measurements, conductivity cells, and potentiometry.

### Typical Applications

- Nanomaterial characterization
- Polymer electrical characterization
- Beam measurements
- Dosimetry
- Device leakage current measurements
- Insulation resistance measurements
- Optoelectronic detector characterization
- Volume and surface resistivity

## Accessories Extend Measurement Capabilities

A variety of optional accessories can be used to extend the 6517B applications and enhance its performance.

The 8009 Resistivity Test Fixture is a guarded test fixture for measuring volume and surface resistivities of sample materials. It has stainless-steel electrodes built to ASTM D257 standards. The fixture's electrode dimensions are pre-programmed into the 6517B, so there's no need to calculate those values then enter them manually. This accessory is designed to protect you from contact with potentially hazardous voltages —opening the lid of the test fixture automatically turns off the 6517B's voltage source.

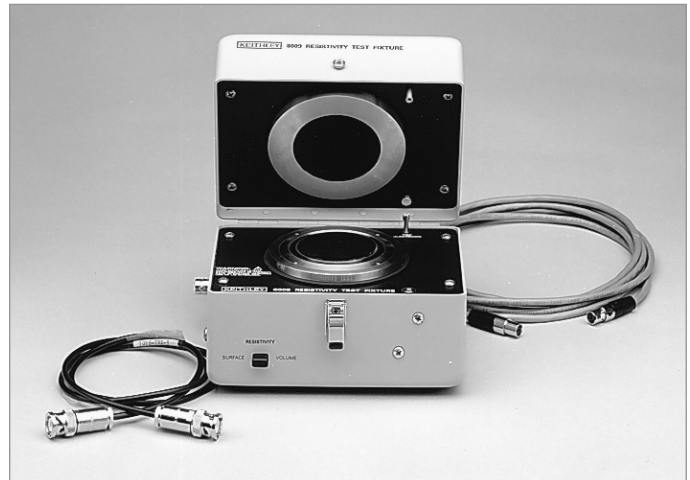

**8009 Resistivity Test Fixture is compliant with American Society for Testing and Materials (ASTM) Standard D257 Standard Test Methods for DC Resistance or Conductance of Insulating Materials. The 8009 combined with the 6517B provides a complete system for making high quality, safe resistivity measurements. The 8009 comes with the 6517B-ILC-3 Safety Interlock Cable, the 7078-TRX-3 Triax-Triax Cable, and the 8607 1 kV Source Voltage Banana Jack Cable Set.**

### 6522 Low Current, 10-Channel Scanner Card

The optional 10-channel plug-in 6522 scanner card is available to extend the measurement performance of the 6517B Electrometer/High Resistance Meter. The card installs directly into the option slot in the back panel of the 6517B. The card is also compatible with the 6517A and 6517.

The 6522 Voltage/Low Current Scanner Card can provide up to ten channels of low-level current, high impedance voltage, high resistance, or charge switching. The 6522's input connectors of the 6522 are 3-lug triax. The card can be software configured for high impedance voltage switching of up to 200 V. Triaxial connectors make it possible to float the card 500 V above ground and drive guard to 200 V.

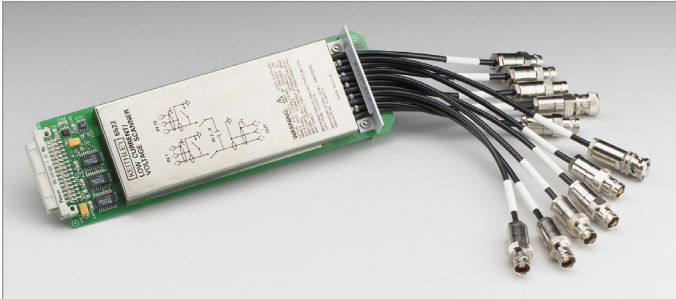

6522 Voltage/Low Current Scanner Card.

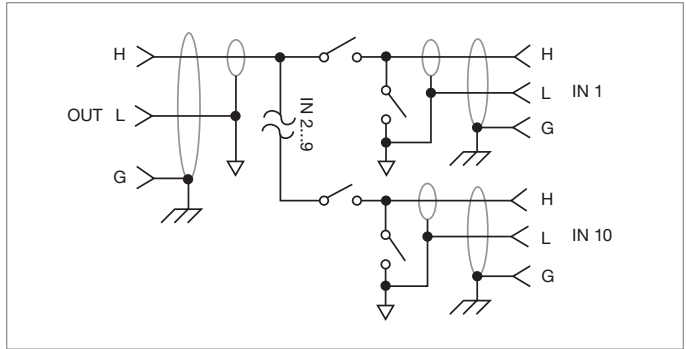

6522 schematic.

## 6522 Specifications

<b>Channels Per Card</b>	10.
<b>Functions</b>	Volts, Amps.
<b>Contact Configuration</b>	Single pole, "break-before-make" for signal HI input. Signal LO is common for all 10 channels and output. When a channel is off, signal HI is connected to signal LO. 6522: 6517B can also configure channels as voltage switches.
<b>Connector Type</b>	Inputs: Triaxial. Outputs: Triaxial.
<b>Signal Level</b>	200 V, 500 mA, 10 VA (resistive load).
<b>Contact Life</b>	>10 <sup>6</sup> closures at maximum signal level; >10 <sup>7</sup> closures at low signal levels.
<b>Contact Resistance</b>	<1 Ω.
<b>Contact Potential</b>	<200 μV.
<b>Offset Current</b>	<1 pA (<30 fA typical at 23°C, <60% RH).
<b>Actuation Time</b>	2 ms.
<b>Common Mode Voltage</b>	<300 V peak.
<b>Channel Isolation (6522)</b>	>10 <sup>13</sup> Ω, <0.3 pF.
<b>Input Isolation (6522)</b>	>10 <sup>10</sup> Ω, <125 pF (Input HI to Input LO).
<b>Environment</b>	Operating: 0°C to 50°C up to 35°C at 70% relative humidity. Storage: -25°C to 65°C.

## Specifications

### Volts

Range	6½-Digit Resolution	Accuracy (1 Year) <sup>1</sup> 18°–28°C ±(% + offset)	Temperature Coefficient 0°–18°C & 28°–50°C ±(% + offset)/°C
2 V	1 µV	0.025 + 40 µV	0.003 + 20 µV
20 V	10 µV	0.025 + 300 µV	0.002 + 100 µV
200 V	100 µV	0.06 + 3 mV	0.002 + 1 mV

**NMRR** 2 V and 20 V ranges: >60 dB. 200 V range: >55 dB. 50 Hz or 60 Hz<sup>2</sup>.

**CMRR** >120 dB at DC, 50 Hz or 60 Hz.

**Input Impedance** >200 TΩ in parallel with 20 pF, <2 pF guarded (1 MΩ with zero check on).

**Small Signal Bandwidth at Preamp Output**  
Typically 100 kHz(–3 dB).

### Notes

- When properly zeroed, 6½-digit, 1PLC (power line cycle), median filter on, digital filter = 10 readings.
- Line sync on.

### Amps

Range	6½-Digit Resolution	Accuracy (1 Year) <sup>1</sup> 18°–28°C ±(% reading + offset)	Temperature Coefficient 0°–18°C & 28°–50°C ±(% reading + offset)/°C
20 pA	10 aA <sup>2</sup>	1 + 3 fA	0.1 + 500 aA
200 pA	100 aA <sup>2</sup>	1 + 5 fA	0.1 + 1 fA
2 nA	1 fA	0.2 + 300 fA	0.1 + 20 fA
20 nA	10 fA	0.2 + 500 fA	0.03 + 100 fA
200 nA	100 fA	0.2 + 5 pA	0.03 + 1 pA
2 µA	1 pA	0.1 + 100 pA	0.005 + 20 pA
20 µA	10 pA	0.1 + 500 pA	0.005 + 100 pA
200 µA	100 pA	0.1 + 5 nA	0.005 + 1 nA
2 mA	1 nA	0.1 + 100 nA	0.008 + 20 nA
20 mA	10 nA	0.1 + 500 nA	0.008 + 100 nA

**Input Bias Current** <3 fA at T<sub>CAL</sub>. Temperature coefficient = 0.5 fA/°C, 20 pA range.

**Input Bias Current Noise** <750 aA p-p (capped input), 0.1 Hz to 10 Hz bandwidth, damping on. Digital filter = 40 readings, 20 pA range.

**Input Voltage Burden at T<sub>CAL</sub> ±1°C**  
<20 µV on 20 pA, 2 nA, 20 nA, 2 µA, and 20 µA ranges.  
<100 µV on 200 pA, 200 nA, and 200 µA ranges.  
<2 mV on 2 mA range. <5 mV on 20 mA range.

**Temperature Coefficient of Input Voltage Burden**  
<10 µV/°C on pA, nA, and µA ranges.

**Preamp Settling Time (to 10% of final value), Typical**  
0.5 s (damping off) 2.0 s (damping on) on pA ranges. 15 ms on nA ranges damping off, 1 ms on µA ranges damping off. 500 µs on mA ranges damping off.

**NMRR** >60 dB on all ranges at 50 Hz or 60 Hz<sup>3</sup>.

### Notes

- When properly zeroed, 6½-digit, 1PLC (power line cycle), median filter on, digital filter = 10 readings.
- aA = 10<sup>-18</sup> A, fA = 10<sup>-15</sup> A.
- Line sync on.

**Ohms (Normal Method)**

Range	6½-Digit Resolution	Accuracy (1 Year) <sup>1</sup> (10–100% Range) 18°–28°C ±(% reading + offset)	Temperature Coefficient (10–100% Range) 0°–18°C & 28°–50°C ±(% reading + offset)	Auto V Source	Amps Range
2 MΩ	1 Ω	0.125 + 10 Ω	0.01 + 10 Ω	40 V	200 μA
20 MΩ	10 Ω	0.125 + 100 Ω	0.01 + 100 Ω	40 V	20 μA
200 MΩ	100 Ω	0.15 + 1 kΩ	0.015 + 1 kΩ	40 V	2 μA
2 GΩ	1 kΩ	0.225 + 10 kΩ	0.035 + 10 kΩ	40 V	200 nA
20 GΩ	10 kΩ	0.225 + 100 kΩ	0.035 + 100 kΩ	40 V	20 nA
200 GΩ	100 kΩ	0.35 + 1 MΩ	0.110 + 1 MΩ	40 V	2 nA
2 TΩ	1 MΩ	0.35 + 10 MΩ	0.110 + 10 MΩ	400 V	2 nA
20 TΩ	10 MΩ	1.025 + 100 MΩ	0.105 + 100 MΩ	400 V	200 pA
200 TΩ	100 MΩ	1.15 + 1 GΩ	0.125 + 1 GΩ	400 V	20 pA

**Notes**

1. Specifications are for auto V-source ohms, when properly zeroed, 6½-digit, 1 PLC, median filter on, digital filter = 10 readings. If user selectable voltage is required, use manual mode. Manual mode displays resistance (up to 10<sup>18</sup> Ω) calculated from measured current. Accuracy is equal to accuracy of V-source plus accuracy of selected Amps range.

**Preamp Settling Time** Add voltage source settling time to preamp settling time in Amps specification. Ranges over 20 GΩ require additional settling based on the characteristics of the load.

**Ohms (Alternating Polarity Method)**

The alternating polarity sequence compensates for the background (offset) currents of the material or device under test. Maximum tolerable offset up to full scale of the current range used.

**Using Keithley 8009 fixture**

**Repeatability**  $\Delta I_{BG} \times R / V_{ALT} + 0.1\% (1\sigma)$  (instrument temperature constant  $\pm 1^\circ\text{C}$ ).

**Accuracy**  $(V_{SRC} \text{Err} + I_{MEAS} \text{Err} \times R) / V_{ALT}$

where:  $\Delta I_{BG}$  is a measured, typical background current noise from the sample and fixture.

$V_{ALT}$  is the alternating polarity voltage used.

$V_{SRC} \text{Err}$  is the accuracy (in volts) of the voltage source using  $V_{ALT}$  as the setting.

$I_{MEAS} \text{Err}$  is the accuracy (in amps) of the ammeter using  $V_{ALT}/R$  as the reading.

**Voltage Source**

Range	5½-Digit Resolution	Accuracy (1 Year) 18°–28°C ±(% setting + offset)	Temperature Coefficient 0°–18°C & 28°–50°C ±(% setting+offset)/°C
100 V	5 mV	0.15 + 10 mV	0.005 + 1 mV
1000 V	50 mV	0.15 + 100 mV	0.005 + 10 mV

**Maximum Output Current** 100 V Range:  $\pm 10$  mA, hardware short circuit protection at <14 mA.  
1000 V Range:  $\pm 1$  mA, hardware short circuit protection at <1.4 mA.

**Settling Time** 100 V Range: <8 ms to rated accuracy.  
1000 V Range: <50 ms to rated accuracy.

**Noise (typical)** 100 V Range: <2.6 mV rms.  
1000 V Range: <2.9 mV rms.

## Coulombs

Range	6½-Digit Resolution	Accuracy (1 Year) <sup>1,2</sup> 18°–28°C, ±(% reading + offset)	Temperature Coefficient 0°–18°C & 28°–50°C ±(% reading + offset)/°C
2 nC	1 fC	0.6 + 50 fC	0.04 + 30 fC
20 nC	10 fC	0.6 + 500 fC	0.04 + 100 fC
200 nC	100 fC	0.4 + 5 pC	0.04 + 1 pC
2 µC	1 pC	0.4 + 50 pC	0.04 + 10 pC

### Notes

1. Specifications apply immediately after charge acquisition. Add

$$\left(4 \text{ fA} + \frac{10 \text{ pC}}{\text{RC}}\right) T_A$$

where  $T_A$  = time in seconds between the coulombs zero and measurement and  $Q_{AV}$  = average charge measured over  $T_A$  and  $\text{RC} = 300,000$  typical.

2. When properly zeroed, 6½-digit, 1 PLC (power line cycle), median filter on, digital filter = 10 readings.

**Input Bias Current** <4 fA at  $T_{\text{CAL}}$ ; temperature coefficient = 0.5 fA/°C, 2 nC range.

## Temperature (Thermocouple)

Thermocouple Type	Range	Accuracy (1 Year) <sup>1</sup> , 18°–28°C ±(% reading + °C)
K	-25°C to 150°C	±(0.3 + 1.5°C)

### Humidity

Range	Accuracy (1 Year) <sup>2</sup> 18°–28°C, ±(% reading + % RH)
0–100%	±(0.3 + 0.5)

### Notes

1. Excluding probe errors,  $T_{\text{CAL}} \pm 5^\circ\text{C}$ , 1 PLC integration time.

2. Humidity probe accuracy must be added. This is  $\pm 3\%$  RH for 6517-RH, up to 65°C probe environment, not to exceed 85°C.

## IEEE-488 Bus Implementation

<b>Implementation</b>	SCPI (IEEE-488.2, SCPI-1999.0).
<b>Trigger to Reading Done</b>	150 ms typical, with external trigger.
<b>RS-232 Implementation</b>	Supports: SCPI 1991.0. Baud Rates: 300, 600, 1200, 2400, 4800, 9600, 19.2k, 38.4k, 57.6k, and 115.2k.
<b>Flow Control</b>	None, Xon/Xoff.
<b>Connector</b>	DB-9 TXD/RXD/GND.

## General Characteristics

<b>Display</b>	6½-digit vacuum fluorescent multiline.
<b>Ovrange Indication</b>	Display reads "OVERFLOW" for readings >105% of range. The display reads "OUT OF LIMIT" for excessive overrange conditions.
<b>Ranging</b>	Automatic or manual.
<b>Conversion Time</b>	Selectable 0.01 PLC to 10 PLC.
<b>Maximum Input</b>	250 V peak, DC to 60 Hz sine wave; 10 s per minute maximum on mA ranges.
<b>Maximum Common Mode Voltage (DC to 60 Hz sine wave)</b>	Electrometer, 500 V peak; V Source, 750 V peak.
<b>Isolation (Meter COMMON to chassis)</b>	>10 <sup>10</sup> Ω, <500 pF.
<b>Input Connector</b>	Three lug triaxial on rear panel.
<b>2 V Analog Output</b>	2 V for full range input. Non-inverting in Volts mode, inverting when measuring Amps, Ohms, or Coulombs. Output impedance 10 kΩ.
<b>Preamp Output</b>	Provides a guard output for Volts measurements. Can be used as an inverting output or with external feedback in Amps and Coulombs modes.
<b>External Trigger</b>	TTL-compatible External Trigger and Electrometer Complete.
<b>Guard</b>	Switchable voltage guard available.
<b>Digital I/O and Trigger Line</b>	Available, see manual for usage.
<b>EMC</b>	Conforms to European Union Directive.
<b>Safety</b>	Conforms to European Union Directive.
<b>Reading Storage</b>	50,000.
<b>Reading Rates</b>	To Internal Buffer: 425 readings/second <sup>1</sup> . To IEEE-488 Bus: 400 readings/second <sup>1,2</sup> . Bus Transfer: 3300 readings/second <sup>2</sup> .  1. 0.01 PLC, digital filters off, front panel off, temperature + RH off, Line Sync off. 2. Binary transfer mode.
<b>Digital Filter</b>	Median and averaging.
<b>Environment</b>	For indoor, non-residential use only.  Operating: 0°–50°C; relative humidity 70% non-condensing, up to 35°C. Storage: -25° to +65°C.
<b>Altitude</b>	Maximum 2000 meters above sea level per EN 61010-1.
<b>Warm-Up</b>	1 hour to rated accuracy (see manual for recommended procedure).
<b>Power</b>	User selectable 100, 120, 220, 240 VAC ±10%; 50/60 Hz, 100 VA maximum.
<b>Physical</b>	Case Dimensions: 90 mm high × 214 mm wide × 369 mm deep (3½ in. × 8½ in. × 14½ in.).  Working Dimensions: From front of case to rear including power cord and IEEE-488 connector: 394 mm (15.5 inches).  Net Weight: 5.4 kg (11.8 lb).  Shipping Weight: 6.9 kg (15.11 lb).

## Ordering Information

6517B	Electrometer/High Resistance Meter
-------	------------------------------------

### Supplied Accessories

237-ALG-2	Low Noise Triax Cable, 3-slot Triax to Alligator Clips, 2 m (6.6 ft)
8607	Safety High Voltage Dual Test Leads
6517-TP	Thermocouple Bead Probe
CS-1305	Interlock Connector

### Available Software

KickStart Software with the High Resistivity Application. Refer to [tek.com](http://tek.com) for licensing details.

### Available Accessories

#### Test Fixture

8009	Resistivity Test Fixture
------	--------------------------

#### Scanner Card

6522	Voltage/Low Current Scanner Card
------	----------------------------------

#### Cables

6517B-ILC-3	Interlock Cable
7007-1	Shielded IEEE-488 Cable, 1 m (3.2 ft)
7078-TRX-x	Low Noise Triax Cable, 3-Slot Triax Connectors, x=3: 0.9 m (3 ft), x=10: 3 m (10 ft), x=20: 6 m (20 ft)
8501-1	Trigger Link Cable, 1 m (3.3 ft)
8503	Trigger Link Cable to 2 male BNCs, 1 m (3.3 ft)

#### Other

CS-1305	Interlock Connector
---------	---------------------

#### Adapters

237-BNC-TRX	Male BNC to 3-Lug Female Triax Adapter
237-TRX-T	3-Slot Male Triax to Dual 3-Lug Female Triax Tee Adapter
237-TRX-TBC	3-Lug Female Triax Bulkhead Connector (1.1 kV rated)
7078-TRX-BNC	3-Slot Male Triax to BNC Adapter
7078-TRX-GND	3-Slot Male Triax to BNC Adapter, guard removed
7078-TRX-TBC	3-Lug Female Triax Bulkhead Connector with Cap

#### Rack Mount Kits

4288-1	Single Fixed Rack Mounting Kit
4288-2	Dual Fixed Rack Mounting Kit

#### GPIB Interfaces

KPCI-488LPA	IEEE-488 Interface/Controller for the PCI Bus
KUSB-488B	IEEE-488 USB-to-GPIB Interface Adapter

## Service Options

<b>6517B-EW</b>	1 Year KeithleyCare Gold Extended Warranty Plan
<b>6517B-3Y-EW-STD</b>	3 Year KeithleyCare Gold Extended Warranty Plan
<b>6517B-5Y-EW-STD</b>	5 Year KeithleyCare Gold Extended Warranty Plan
<b>C/6517B-3Y-STD</b>	KeithleyCare 3-Calibration, 3-Year Standard Calibration Plan
<b>C/6517B-3Y-DATA</b>	KeithleyCare 3-Calibration, 3-Year Calibration Plan with Data
<b>C/6517B-3Y-17025</b>	KeithleyCare 3-Calibration, 3-Year ISO 17025 Calibration Plan
<b>C/6517B-5Y-STD</b>	KeithleyCare 5-Calibration, 5-Year Standard Calibration Plan
<b>C/6517B-5Y-DATA</b>	KeithleyCare 5-Calibration, 5-Year Calibration Plan with Data
<b>C/6517B-5Y-17025</b>	KeithleyCare 5-Calibration, 5-Year ISO 17025 Calibration Plan

## Warranty Information

<b>Warranty Summary</b>	This section summarizes the warranties of the 6517B. For complete warranty information, refer to the Tektronix warranty page at <a href="https://www.tek.com/service/warranties/warranty-2">https://www.tek.com/service/warranties/warranty-2</a> . Any portion of the product that is not manufactured by Keithley is not covered by this warranty and Keithley will have no duty to enforce any other manufacturer's warranties.
<b>Hardware Warranty</b>	Keithley Instruments, Inc. warrants the Keithley manufactured portion of the hardware for a period of one year from defects in materials or workmanship; provided that such defect has not been caused by use of the Keithley hardware which is not in accordance with the hardware instructions. The warranty does not apply upon any modification of Keithley hardware made by the customer or operation of the hardware outside the environmental specifications.
<b>Software Warranty</b>	Keithley warrants for the Keithley produced portion of the software or firmware will conform in all material respects with the published specifications for a period of ninety (90) days; provided the software is used on the product for which it is intended in accordance with the software instructions. Keithley does not warrant that operation of the software will be uninterrupted or error-free, or that the software will be adequate for the customer's intended application. The warranty does not apply upon any modification of the software made by the customer.

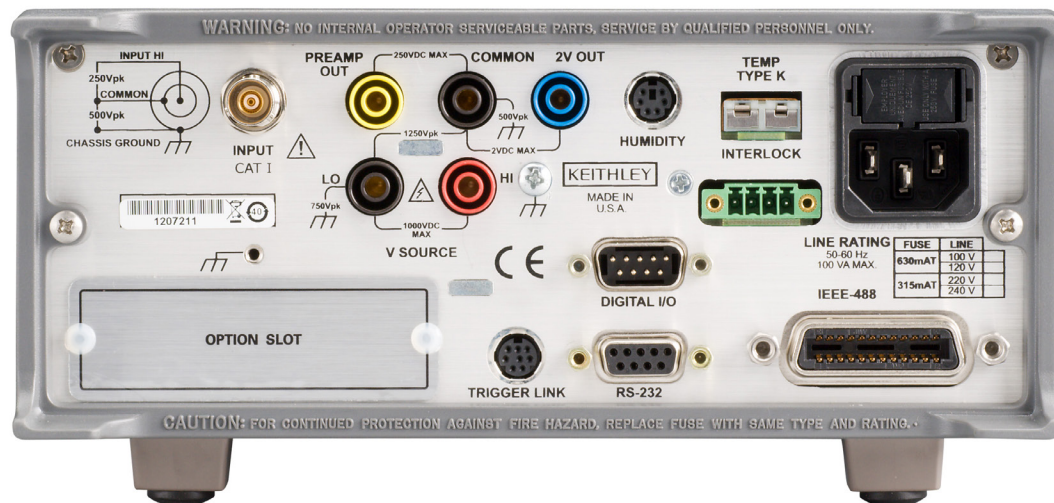

6517B rear panel.

## Contact Information:

Australia 1 800 709 465  
Austria\* 00800 2255 4835  
Balkans, Israel, South Africa and other ISE Countries +41 52 675 3777  
Belgium\* 00800 2255 4835  
Brazil +55(11) 3530-8901  
Canada 1 800 833 9200  
Central East Europe / Baltics +41 52 675 3777  
Central Europe / Greece +41 52 675 3777  
Denmark +45 80 88 1401  
Finland +41 52 675 3777  
France\* 00800 2255 4835  
Germany\* 00800 2255 4835  
Hong Kong 400 820 5835  
India 000 800 650 1835  
Indonesia 007 803 601 5249  
Italy 00800 2255 4835  
Japan 81(3) 6714 3086  
Luxembourg +41 52 675 3777  
Malaysia 1 800 22 55835  
Mexico, Central/South America and Caribbean 52 (55) 88 69 35 25  
Middle East, Asia, and North Africa +41 52 675 3777  
The Netherlands\* 00800 2255 4835  
New Zealand 0800 800 238  
Norway 800 16098  
People's Republic of China 400 820 5835  
Philippines 1 800 1601 0077  
Poland +41 52 675 3777  
Portugal 80 08 12370  
Republic of Korea +82 2 565 1455  
Russia / CIS +7(495) 6647564  
Singapore 800 6011 473  
South Africa +41 52 675 3777  
Spain\* 00800 2255 4835  
Sweden\* 00800 2255 4835  
Switzerland\* 00800 2255 4835  
Taiwan 886 (2) 2656 6688  
Thailand 1 800 011 931  
United Kingdom / Ireland\* 00800 2255 4835  
USA 1 800 833 9200  
Vietnam 12060128

\* European toll-free number. If not accessible, call: +41 52 675 3777

Rev. 02.2022



Find more valuable resources at [TEK.COM](http://TEK.COM)

Copyright © Tektronix. All rights reserved. Tektronix products are covered by U.S. and foreign patents, issued and pending. Information in this publication supersedes that in all previously published material. Specification and price change privileges reserved. TEKTRONIX and TEK are registered trademarks of Tektronix, Inc. All other trade names referenced are the service marks, trademarks or registered trademarks of their respective companies.

071026 KEI 1KW-60280-2

