

## DDA-06

6-Channel, 12-Bit ISA-Bus  
Analog Output Board

### FEATURES

- 6 analog output channels
- 12-bit resolution
- +5, +10, ±2.5, ±5, ±10V output ranges
- 4–20mA current loop capability (sink)
- 24 bits of parallel digital I/O
- Simultaneous updating on all channels (switch selectable)
- Software included: Windows 3.X/95/98, setup, calibration, programming examples and Windows DLL

### APPLICATIONS

- Servo control
- Programmable voltage source
- Programmable current sink
- Function generator
- Product testing
- Use with Keithley's SSIO-24 and ERB-24 (through STA-U)

### Functional Description

Keithley's DDA-06 is an analog output and digital I/O board for ISA-bus based PCs providing 6 channels of 12-bit analog output and 24 lines of digital I/O.

The following functions are implemented on the DDA-06:

- 6 independent 12-bit D/A converters. Each is individually switch selectable to any of the following ranges: 0 to +10V, 0 to +5V, -2.5V to +2.5V, -5V to +5V, -10V to +10V, 4–20mA current loop (sink)
- Each D/A has a double-buffered input for single-step update and occupies its own I/O location. By means of jumper blocks, it is possible to select any or all of the D/As to update simultaneously. Since each D/A output uses one pin of the rear 37-pin D-type connector, the D/As can be operated in either voltage output mode or current output (but not both simultaneously). In voltage mode, output settling time is typically 3 microseconds to 0.01% for a full-scale step.
- 24 bits of digital I/O are provided on the rear connector consisting of 3 ports of 8 bits. Each port can be programmed independently as an input or output and is TTL/CMOS compatible. An 8255 programmable peripheral interface chip is used for digital I/O and can be operated in the 8255 modes 0–2 (straight I/O, strobed I/O, and bidirectional I/O).

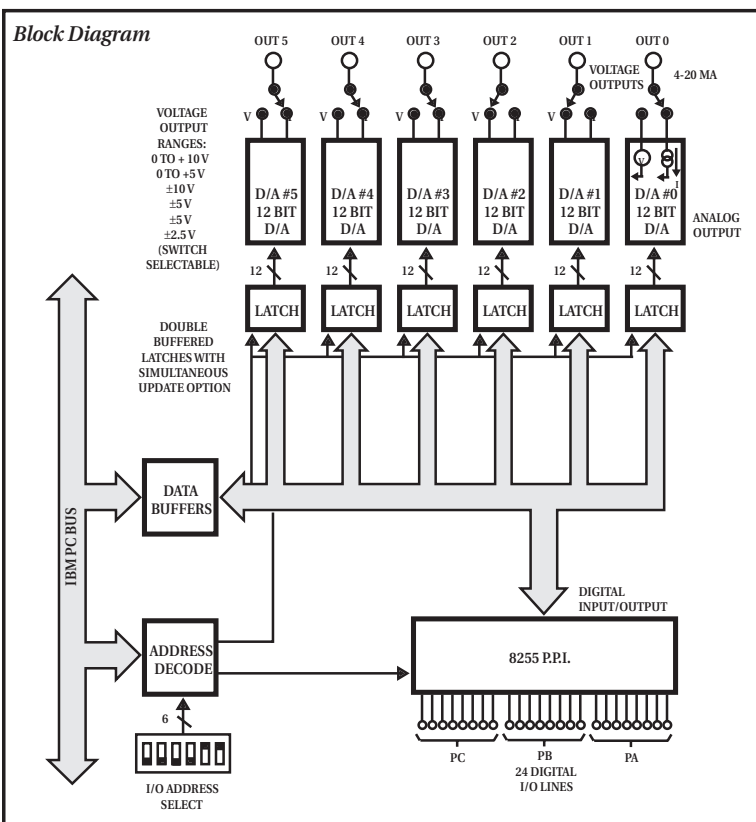
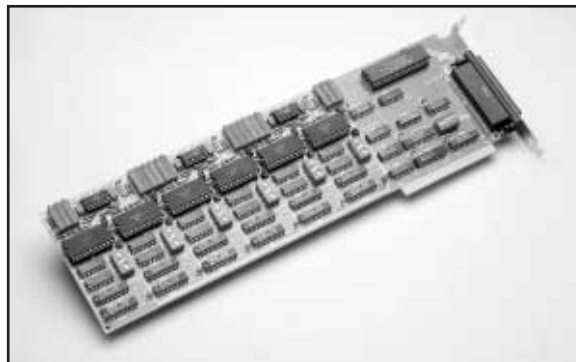

### Software

The following utility software is included with the DDA-06.

1. Initial setup and installation aids
2. Calibration program
3. Programming examples and demonstration programs
4. A port I/O DLL for operation under Windows and an example program

No driver is supplied with the DDA-06 since programming is simple using I/O instructions in most programming languages (e.g., BASIC, QuickBASIC, C, Turbo-Pascal, etc.). Writing to a D/A converter is a simple two step procedure. The least significant 8 bits of the output word are written to the board, then the most significant four bits are written. The D/A is automatically updated when the MSBs are written. The optional DASDLL-DDA-06 is a full-featured driver for using the DDA-06 in Windows 3.X.

### TestPoint

By providing a graphical drag-and-drop interface for acquisition of data from IEEE-488 instruments, data acquisition boards, and RS-232/485 instruments and devices, TestPoint lets you create applications without programming.

A fully featured, integrated application package, TestPoint incorporates many commonly used math, analysis, report generation, and graphics functions. Read about it, beginning on page 307.

### QUESTIONS?

1-800-552-1115 (U.S. only)

Call toll free for technical assistance, product support or ordering information, or visit our website at [www.keithley.com](http://www.keithley.com).

## DDA-06

### Configuration Guide

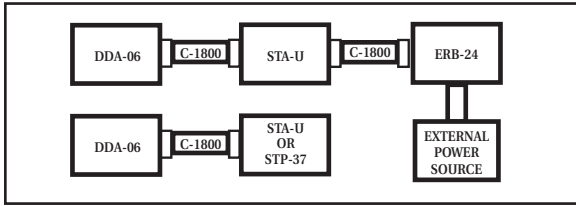

### Connector Pin Assignments

All I/O is through a standard 37-pin D-type male connector that projects through the rear panel of the computer. For soldered connections, a standard 37-pin D female (ITT/Cannon DC-37S or equivalent) is the correct mating part and can be ordered from Keithley as part number SFC-37.

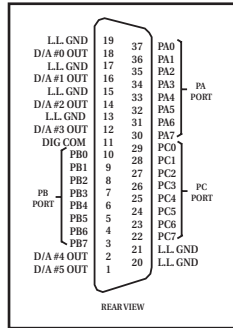

## SPECIFICATIONS

### D/A Converters

- CHANNELS:** 6.
- RESOLUTION:** 12-bits (1 part in 4095 decimal).
- D/A TYPE:** DAC-80N (6 used).
- LATCHES:** Double buffered with optional simultaneous update.
- LINEARITY:**  $\pm 1/2$  bit.
- MONOTONICITY:**  $\pm 1/2$  bit.
- TEMPERATURE DRIFT OF UNIPOLAR OFFSET:** 1ppm typ 3ppm max of full scale range (per °C).
- TEMPERATURE DRIFT OF BIPOLAR OFFSET:** 7ppm typ 15ppm max of full scale range (per °C).
- TEMPERATURE DRIFT OF GAIN:** 15ppm typ/30ppm max.
- OUTPUT RANGES:** 0 to +5V, 0 to +10V, -2.5 to +2.5V, -5 to +5V, -10 to +10V, 4-20mA (current sink to ground).

### Voltage Output Characteristics

- LOAD CURRENT:**  $\pm 5$ mA min.
- SHORT CIRCUIT CURRENT:** 40mA max.
- OUTPUT RESISTANCE:**  $< 0.1\Omega$ .
- SETTLING TIME:** 4 $\mu$ s max to 0.01 % for full-scale step.

### Digital Inputs/Outputs

- TYPE:** 8255 PPI, supports all modes.
- NUMBER:** 24 lines (3 8-bit ports)
- CONTROL:** Each port software programmable as input or output.
- INPUT LOGIC LOW LEVEL:** -0.5V min to +0.8V max.
- INPUT LOGIC HIGH LEVEL:** +2.4V min to +5.0V max.
- INPUT CURRENT:** +1 $\mu$ A (logic high or low).
- OUTPUT LOW SINK CURRENT:** 1.7mA at  $V_{OL} = 0.45$ V.
- OUTPUT HIGH SOURCE CURRENT:** -200 $\mu$ A at  $V_{OH} = 2.4$ V.
- \*DARLINGTON DRIVE CURRENT:** -1mA min/-4mA max at 1.5V.

\* Available on any 8 pins simultaneously from PB and PC ports.

### Typical Output Configurations

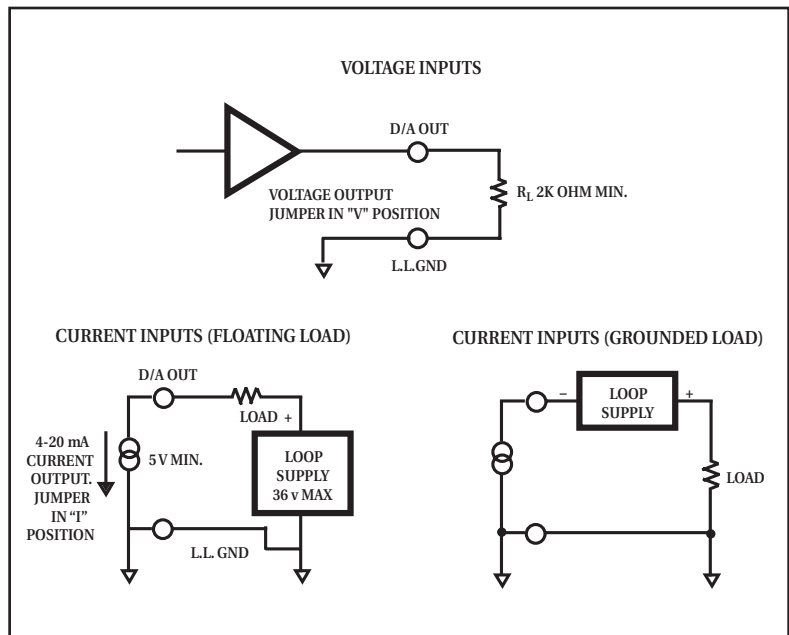

### Current Loop Characteristics

- TYPE:** 4-20mA constant current sink to ground.
- OUTPUT RESISTANCE:** 100M $\Omega$ .
- MIN LOOP EXCITATION VOLTAGE:** +6V.
- MAX LOOP EXCITATION VOLTAGE:** +36V.

### Power Requirements

- +5V:** 450mA typ/550mA max.
- +12V:** 60mA typ/100mA max.
- 12V:** 140mA typ/180mA max.

### General Environmental

- OPERATING TEMPERATURE RANGE:** 0 to 50°C.
- STORAGE TEMPERATURE RANGE:** -20 to +70°C.
- HUMIDITY:** 0 to 90% non-condensing.
- DIMENSION:** 13.3in L  $\times$  4.25in H  $\times$  0.75in D (33.8cm  $\times$  10.8cm  $\times$  1.9cm).

ORDER	DESCRIPTION
DDA-06*	6-Channel Analog Output Board
<b>OPTIONS</b>	
C1800	STA-U, STP-37 to DDA-06 Cable (18 inches)
DASDLL-DDA-06*	Windows 3.X Driver (can be obtained free from our website)
ERB-24	Electromechanical Relay Board
MS-DDA-06*	Additional Hardware and Software Manual and Software
STA-U	Screw Terminal Accessory Board
STC-37	Screw Terminal Connector
STP-37	Screw Terminal Panel
TESTPOINT	TestPoint Software Package

\* Software supplied on 3.5 inch disks

See page 479 for descriptions of all accessories.