

DisplayPort 1.4 and Type-C Compliance/Debug Solution

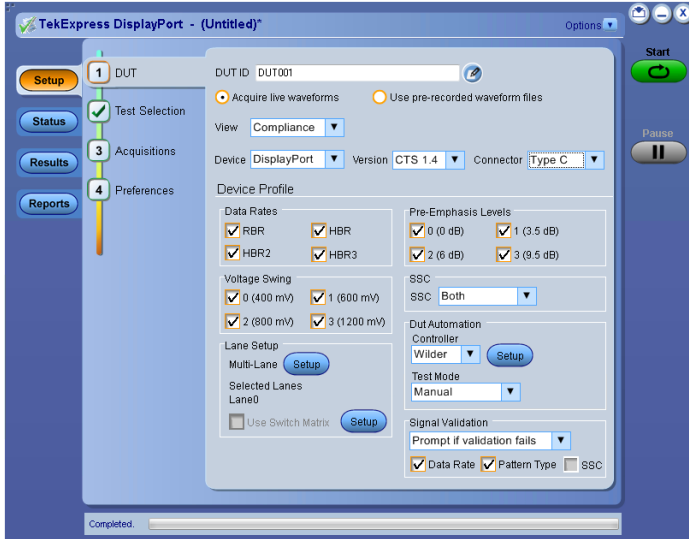

TekExpress DisplayPort DUT Panel

Tektronix provides DisplayPort 1.4 and Type-C compliance/debug solutions and DisplayPort 1.2 receiver solutions.

DisplayPort 1.4 and Type-C Compliance/Debug solution key features

- Complete automated compliance testing in less than 7 hours for data rates up to HBR2 and less than 11 hours for data rates up to HBR3
- Intelligent pattern recognition before test execution
- Fixture de-embed feature → Use the default filter file for de-embedding fixture effect or create a custom filter file using SDLA software to leverage the channel modeling and receiver equalization functionality
- Easy option to support repeatability of measurements
- Customization of reports according to Tests, Lanes, Data Rates or Pass/Fail results
- Timer pop-ups for **zero** user interaction during entire DisplayPort testing
- Enhanced TekExpress report with new measurement plots
- Single application for Standard and Type-C DisplayPort testing
- 100% DisplayPort High Speed transmitter test coverage
- Complete DUT automation for hands free testing
- Simplistic User Experience with single UI for DUT configuration
- Optimized algorithms execute tests with improved accuracy
- Optional signal validation helps to detect anomalies quickly in the signal
- Reports available in mht, pdf and csv formats for advanced data analysis
- Compliance (TekExpress) and Characterization (DPOJET) test support
- Support for DUT automation over SCPI based Programmatic Interface (PI)
- Automation support and scripting interface with Iron Python which supports socket based programming remote interface
- Supports Manual and Automated test modes for Type-C and Standard DP testing
- Stand-alone utility support for DPR-100 aux controller
- Capture and save DUT waveforms for offline analysis
- Support for Tektronix pre-compliance Type-C fixture which supports testing for USB, DisplayPort, and Thunderbolt 3 over Type-C connector

DisplayPort 1.2 Receiver solution key features

- Automated DisplayPort Sink electrical calibration and compliance testing consistent with the VESA DP 1.2b Sink MOI (Method of Implementation)
- 100% coverage of Sink Jitter Tolerance Tests per DisplayPort PHY 1.2b CTS
- Automated DDJ (ISI) calibration & Jitter Margin testing at user-defined Jitter Frequency Steps
- Support for multiple Variable ISI Hardware Solutions
- Simple Setup, Test Execution, and Reporting in HTML and .csv formats
- Fully integrated with Unigraf DPT-200 DisplayPort AUX Channel Reference Source
- Automates checking of DisplayPort Configuration Data (DPCD) registers for Bit Error Rate (BER) validation

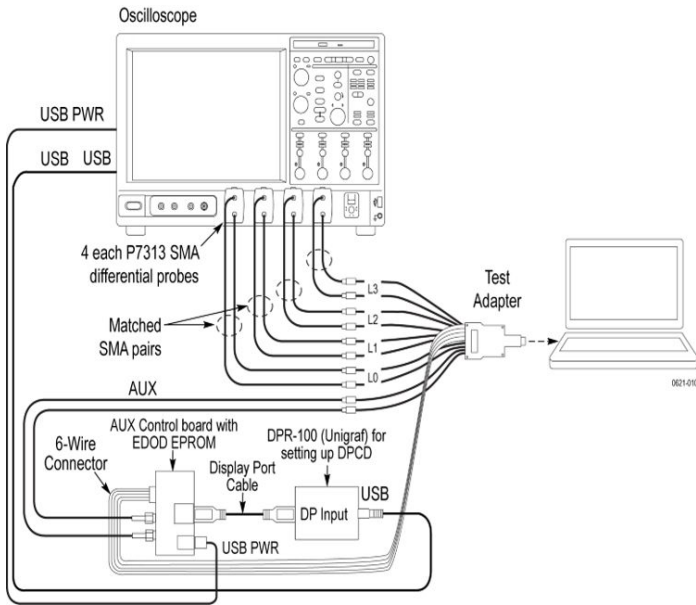

DisplayPort Transmitter Test Overview

DisplayPort sources (transmitters) have state control requirements in order to transmit the data patterns and signal properties required to demonstrate conformance to the Compliance Test Specification. The following properties and patterns need to be transmitted for full measurement coverage:

- Bit rates: RBR, HBR, HBR2, and HBR3
- Data patterns: D10.2, PRBS7, COMPEYE, PLTPAT
- FFE (pre-emphasis): 0 dB, 3.5 dB, 6 dB, 9.5 dB
- Output levels: 400 mV, 600 mV, 800 mV, 1200 mV
- SSC (spread spectrum): On/Off

TekExpress Compliance Solution Overview

TekExpress provides automated test support for Standard and Type-C DisplayPort Compliance Testing. The new and advanced TekExpress DisplayPort application leverages the features of the latest TekExpress 4.0 framework and optimizes the overall testing by nearly three times.

TekExpress Automated Test Solution			
TekExpress DisplayPort			
Setup Information			
DUT ID	DUT001	Scope Model	MSO72304DX
Date/Time	2016-11-04 13:53:01	Scope Serial Number	B260755
Device Type	DisplayPort	SPC, Factory Calibration	PASS,PASS,??
App Version	Display Port: 10.1.0.38 (Evaluation Version)	Scope F.W. Version	10.3.5 Build 3
TekExpress Version	Framework: 4.1.1.2	DPCD V. Version	10.0.1.6
Execution Mode	Pre-Recorded	ProbeCH1 Model	N.A
Overall Compliance Mode	Yes	ProbeCH1 Serial Number	N.A
Overall Result	Pass	ProbeCH2 Model	N.A
Overall Execution Time	0:33:13	ProbeCH2 Serial Number	N.A
DUT Automation Method	DPR-100	ProbeCH3 Model	N.A
Connector	Standard	ProbeCH3 Serial Number	N.A
CTS Version	CTS 1.4	ProbeCH4 Model	N.A
DPR100 Version	DF Rev 1.2	ProbeCH4 Serial Number	N.A
DUT COMMENT: General Comment = DisplayPort			

Test Name Summary Table	
Test 3.1. Eye Diagram Testing	Pass
Test 3.2. Non Pre-Emphasis Level Verification Testing	Pass
Test 3.3. Pre-Emphasis Level Verification Testing	Pass
Test 3.12.1. Total Jitter (TJ) Measurements	Pass
Test 3.12.2. Random Jitter (RJ) Measurements	Pass
Test 3.14. Main Link Frequency Compliance	Pass
Total Measurements Executed : 100 - Pass = 73 - Fail = 27 - Skipped = 0 - Error = 0	

Detailed report with summary table

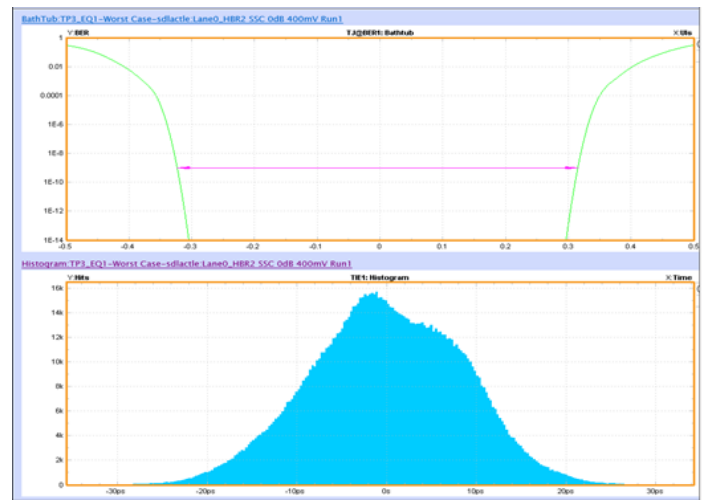

Bathtub and Histogram plot for HBR2 datarate at TP3_EQ

Case	Measurement Details	Measured V Units	Test Result	Margin	Low Limit	High Limit
Test 3.1_Eye diagram testing						
Lane0	Width TP3_EQ1-No Cable-sdIactle:HBR2 NoSSC Odb 400mV Run 1	0.6295 UI	Pass	0.2095	0.42	N.A
Lane0	MaskHits TP3_EQ1-No Cable-sdIactle:HBR2 NoSSC Odb 400mV Run 1	0 Hits	Pass	0	N.A	0
Lane0	Height TP3_EQ1-No Cable-sdIactle:HBR2 NoSSC Odb 400mV Run 1	249.4505 mV	Pass	145.4505	104	N.A
Lane0	Width TP3_EQ1-Worst Case-sdIactle:HBR2 NoSSC Odb 400mV Run 1	0.8 UI	Pass	0.38	0.42	N.A
Lane0	MaskHits TP3_EQ1-Worst Case-sdIactle:HBR2 NoSSC Odb 400mV Run 1	0 Hits	Pass	0	N.A	0
Lane0	Height TP3_EQ1-Worst Case-sdIactle:HBR2 NoSSC Odb 400mV Run 1	144.8584 mV	Pass	40.8584	104	N.A
Lane0	Width TP3_EQ1-No Cable-sdIactle:HBR2 NoSSC Odb 600mV Run 1	0.6463 UI	Pass	0.2263	0.42	N.A
Lane0	MaskHits TP3_EQ1-No Cable-sdIactle:HBR2 NoSSC Odb 600mV Run 1	0 Hits	Pass	0	N.A	0
Lane0	Height TP3_EQ1-No Cable-sdIactle:HBR2 NoSSC Odb 600mV Run 1	380.7612 mV	Pass	276.7612	104	N.A
Lane0	Width TP3_EQ1-Worst Case-sdIactle:HBR2 NoSSC Odb 600mV Run 1	0.7914 UI	Pass	0.3714	0.42	N.A
Lane0	MaskHits TP3_EQ1-Worst Case-sdIactle:HBR2 NoSSC Odb 600mV Run 1	0 Hits	Pass	0	N.A	0
Lane0	Height TP3_EQ1-Worst Case-sdIactle:HBR2 NoSSC Odb 600mV Run 1	214.2772 mV	Pass	110.2772	104	N.A
Lane0	Width TP3_EQ1-No Cable-sdIactle:HBR2 NoSSC Odb 800mV Run 1	0.7513 UI	Pass	0.3313	0.42	N.A
Lane0	MaskHits TP3_EQ1-No Cable-sdIactle:HBR2 NoSSC Odb 800mV Run 1	0 Hits	Pass	0	N.A	0
Lane0	Height TP3_EQ1-No Cable-sdIactle:HBR2 NoSSC Odb 800mV Run 1	465.7673 mV	Pass	359.7673	104	N.A
Lane0	Width TP3_EQ1-Worst Case-sdIactle:HBR2 NoSSC Odb 800mV Run 1	0.7803 UI	Pass	0.3603	0.42	N.A
Lane0	MaskHits TP3_EQ1-Worst Case-sdIactle:HBR2 NoSSC Odb 800mV Run 1	0 Hits	Pass	0	N.A	0
Lane0	Height TP3_EQ1-Worst Case-sdIactle:HBR2 NoSSC Odb 800mV Run 1	252.7227 mV	Pass	148.7227	104	N.A
Lane0	Width TP3_EQ1-No Cable-sdIactle:HBR2 NoSSC Odb 1200mV Run 1	0.6381 UI	Pass	0.2181	0.42	N.A
Lane0	MaskHits TP3_EQ1-No Cable-sdIactle:HBR2 NoSSC Odb 1200mV Run 1	0 Hits	Pass	0	N.A	0
Lane0	Height TP3_EQ1-No Cable-sdIactle:HBR2 NoSSC Odb 1200mV Run 1	258.6139 mV	Pass	154.6139	104	N.A

CSV reporting for data analysis

Transmitter Eye Diagram Measurement:

The screen shots below show how an adaptive mask is used in a DP Eye diagram measurement.

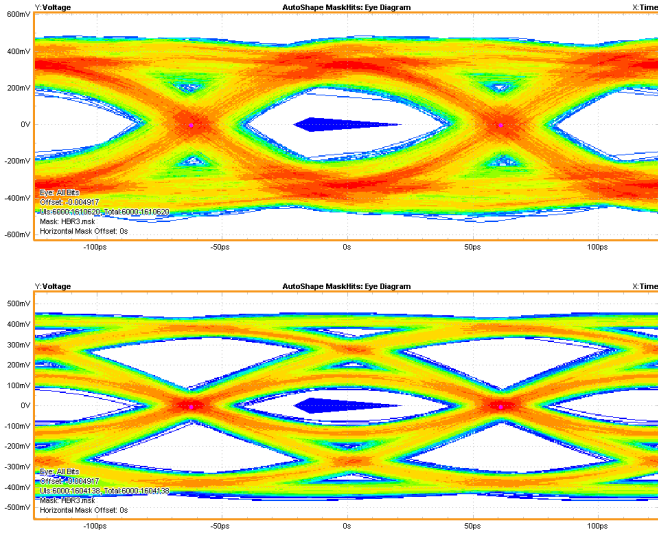

Eye-diagram with dynamic mask generation capability

According to the spec, the eye diagram needs to follow the mask limits:

- Eye diagram width is established at any passing location along 0mV.
- Eye diagram height (symmetric around 0mV) is established at any passing location between 0.375 to 0.625UI.

The measured eye must be equal to or larger than the appropriate eye mask.

The TekExpress application leverages the DPOJET analysis engine to generate a dynamic mask appropriate to the acquired signal and auto adjusts the position of the mask based on eye opening along the horizontal axis. The vertical coordinates are placed at the eye mask location corresponding to the max amplitude level.

Compliance to Characterization Support

Along with TekExpress solution, Tektronix offers DisplayPort DPOJET essentials package which comes bundled with TekExpress and can be used to characterize a DUT and analyzing its finer behavior. It serves as an analysis tool when the DUT fails any portion of the compliance tests or user wants to take a deeper look into the failures. All the compliance tests which are supported in TekExpress and require a single acquisition are supported in this package. The user can build automation scripts around these measurements to setup a custom test environment.

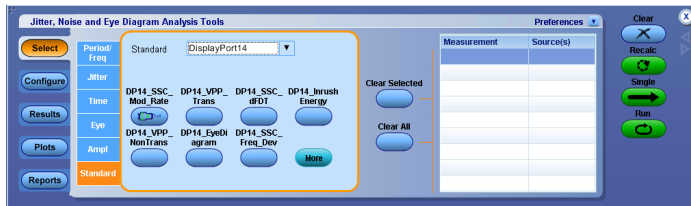

DisplayPort DPOJET Essentials package

You can enable this package by running 'DisplayPort 1.4 essentials' from the Scope → Analyze menu. The DisplayPort DPOJET measurement library helps in characterizing the silicon. Other advantages of this library is the ability to debug the measurement in case of failures. If any of the tests fail during compliance testing, users can tap into the DPOJET DisplayPort measurement library for a dive deeper into the failures such as Eye diagram mask hit failures and look at relation between Pre-emphasis level vs Voltage swing tests to perform root cause analysis. The solution also gives users the flexibility to configure measurements at different settings, make configuration changes in existing measurements on the fly and run tests in single-shot or free-run repetitive modes.

Introducing DPR-100 utility

This new utility helps verify setup connections and DUT behavior before running compliance tests and comes bundled with TekExpress DP 1.4 installer. The utility controls DPR-100 Aux controller to change the DUT settings like data rates, patterns and levels. The utility also helps control PD controller as part of DisplayPort Type-C setup.

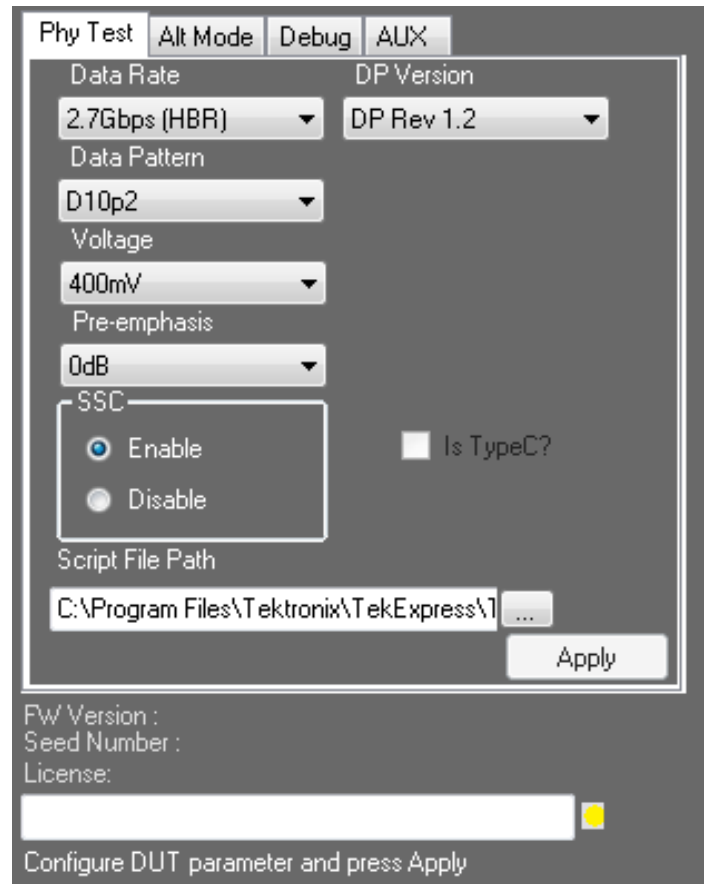

DPR-100 utility

SDLA Features

SDLA enables user to probe and visualize data at the required location (de-embed / embed) using virtual probing through test points. It can remove (de-embed) the effects of the cables, probes and fixtures to get more accurate measurement results. It can embed user defined channel models to simulate the signal at the end of the link. It can also be used to open a closed eye using receiver equalization, Continuous Time Linear Equalizer (CTLE), Decision Feedback (DFE), or Feed Forward Equalization (FFE). SDLA also has advanced analysis and modeling capabilities. One can view and measure multiple test points using DPOJET Jitter and Eye analysis comprehensive frequency and time domain plots, enable quick verification of S-parameters and test point transfer functions.

Switch Matrix support

Switch Matrix for DisplayPort (SWX-DP) is a software solution integrated with TekExpress DisplayPort application which simplifies the user experience to configure and setup automated multi-lane testing using RF switch.

The user can perform both differential and single ended tests as per DP 1.2/1.4 spec, without a need to make change connections. which significantly cuts down the test times.

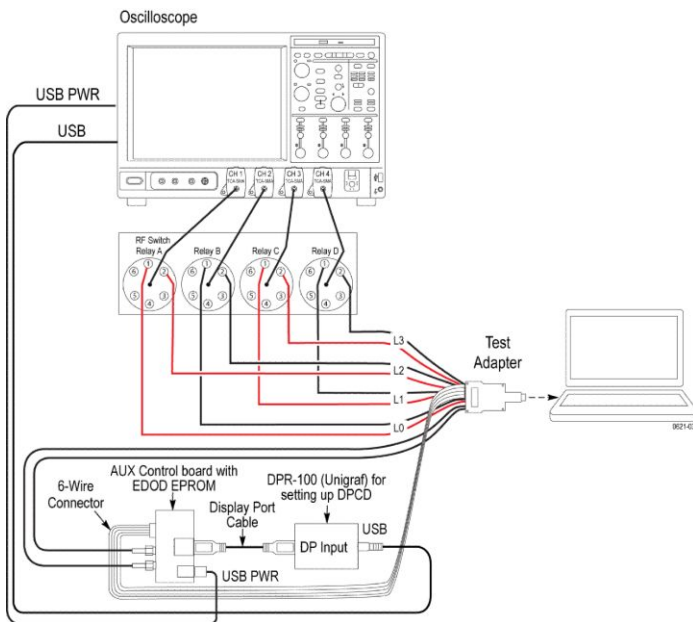

Key features of SWX-DP include:

- Auto Detects the Keithley switch on the GPIB/LAN interface.
- De-embed using filter files – with multiple de-embed options (per relay, per input, etc.).
- Operates with TekExpress and DPOJET (Debug Mode).
- Save/recall switch configurations.
- Graphical view with print option to support hardware wiring.
- Graphical view integration with TekExpress report.
- Built-in error handling to support easy and error-free configuration.
- Support for custom input labels such as Lane, Port, etc. via XML file edits.
- Programmatic interface to support scripting and easy integration into user’s automation environment.

DisplayPort 1.2 Receiver solution

DisplayPort Sink Test automation software overview

The DisplayPort Sink Test Automation Software for the Tektronix BERTScope (TEK-GRL-DP-SINKSW) provides an automated, simple, and efficient way to test DisplayPort Sink (Receiver) devices per the Jitter Tolerance requirements of the DisplayPort Physical Layer Compliance Test Specification (CTS) version 1.2.

The GRL-DP-SINK application automates single and multi-lane measurements at all DisplayPort data rates 1.62, 2.7, and 5.4 Gb/s (RBR, HBR, and HBR2), and runs on a 70K series Windows 7 OS-based Oscilloscope.

The test automation software eliminates the need for user interaction during testing. It enables automated calibration between the BERTScope and real-time scope to generate stressed-signal conditions for DisplayPort 1.2b PHY CTS Sink Compliance testing.

The unique DDJ (ISI) calibration feature incorporated into the software eliminates the need for fixed ISI boards, and supports multiple test cases without change in setup (such as Long Channel, Short Channel, No Channel) The software supports multiple Variable ISI Hardware Solutions, including the Tektronix BERTScope DPP125C + LE320 Variable ISI, and Artek CLE1000-A1 Low Frequency Variable ISI.

The combination of test automation software and an AUX Channel Controller (Unigraf DPT-200 Reference Source with AUX Control) automates Link Training and BER validation. The Margin Test feature stresses the Receiver to failure at user-defined Jitter Frequency Steps, revealing the true capabilities of your Receiver design.

Calibration and compliance testing

Refer to VESA DisplayPort PHY CTS Rev. 1.2b and Tektronix Method of Implementation (MOI) for specific details.

The receiver testing comprises of a two-step operation. Calibration and Compliance testing.

Calibration

Refer to the following figure for the calibration setup:

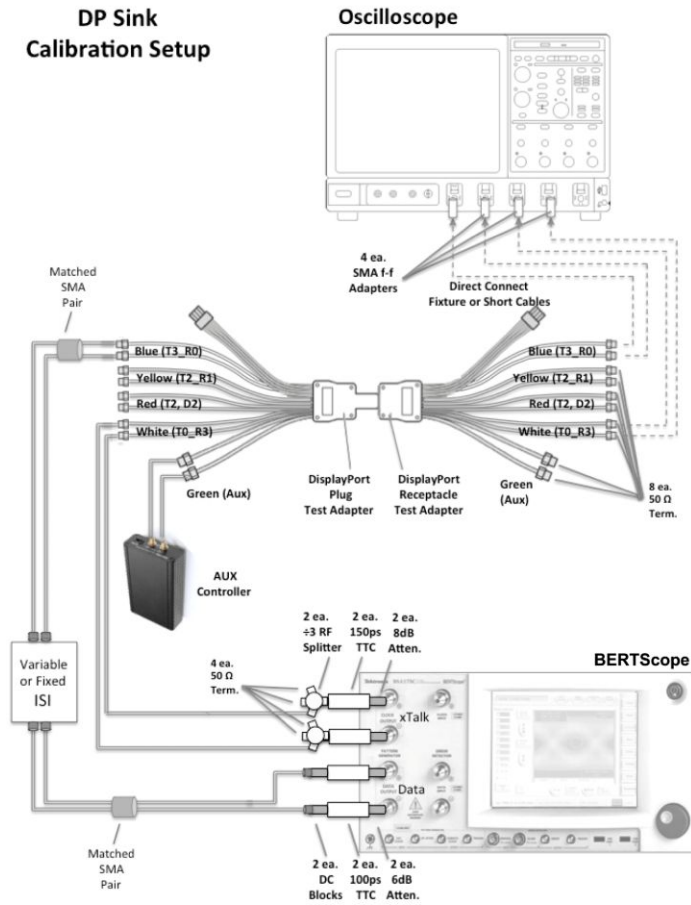

Calibration setup

The following DUT parameters are calibrated in the first step of calibration:

- ISI calibration:
 - The software sets up DPOJET to measure the ISI (DDJ) of the Channel that is connected as per the specification. This measurement is at TP3 for RBR and TP3_Eq for HBR and HBR2. If the measured DDJ is within the target value of the spec, the software reports a pass.
 - A variable ISI channel can be used to more easily adjust the channel to be within the specification. The test automation software supports automated control of the Tektronix BSAITS or ARTEK CLE1000-A2 variable ISI generator.
- Random jitter:
 - This step calibrates RJ on the BERTScope. The pattern changes from CP_2520 (or PRBS-7 for HBR, RBR) to 1100 for RJ calibration.
- SJ Fixed:
 - (This is for HBR2 only). 1100 pattern is used for SJ_Fixed Calibration.

- SJ Sweep:
 - All SJ Frequencies are calibrated as part of this step. 1100 is the pattern used.
- Crosstalk:
 - This step calibrates the xTalk amplitude on the BERTScope. The signal amplitude being calibrated on Ch3-Ch4 with 1/4 Rate Clock from the Clock outputs of the BERTScope.
- Eye-Height:
 - This step calibrates the Eye Height on the BERTScope. The pattern for Eye Height is changed back to the Compliance Pattern (CP_2520 for HBR2, PRBS-7 for RBR and HBR).

Testing the DUT for CTS Compliance

Refer to the following figure for the test setup:

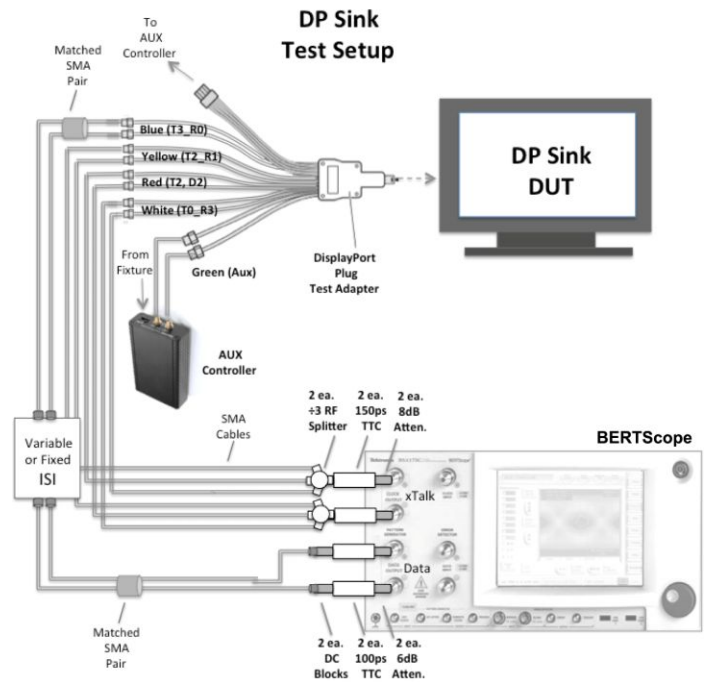

Test setup

The BERTScope outputs stressed pattern as defined in specification with RJ, SJ, and ISI jitter injected. The error counter is initially cleared. The sink compliance tests are run for a specified time. If the Sink DUT supports aux communication, then after the specified test time, the error counter is read through by reading sink DPCD register.

The software test application supports automated testing of a sink device if the sink device supports standard DPCD through the AUX channel. Unigrاف DPT-200 Aux controller is required for this test. The test software performs link training and then performs jitter tolerance at selected frequencies. Test matrix for BER measurement are defined in the specification. Refer to table 4-1 of DisplayPort 1.2 spec. After all test conditions are complete, a compliance report is generated.

For Compliance, it is sufficient to perform the compliance tests on each test condition. However, it is often useful to understand how much margin your design has. The test software provides ability to margin test the DUT by considering Minimum bits to be tested, Maximum errors, Jitter step size and Minimum step size. There is also a provision to generate Calibration and Margin test plots.

Specifications

List of Measurements Supported as per DP 1.4 Standard/Type-C CTS

- 3.1 Eye-diagram Testing
- 3.2 Non Pre-Emphasis Level Verification Testing
- 3.3 Pre-Emphasis Level Verification Testing
- 3.4 Inter Pair Skew Test
- 3.5 Intra-Pair Skew Test
- 3.10 AC Common Mode Noise
- 3.11 Non ISI Jitter Measurements
- 3.12.1 Total Jitter (TJ) and Deterministic (DJ) Measurements
- 3.12.2 Random Jitter (RJ) Measurements
- 3.14 Main Link Frequency Compliance
- 3.15 Spread Spectrum Modulation Frequency
- 3.16 Spread Spectrum Modulation Deviation
- 3.17 dF/dt Spread Spectrum Deviation HF Variation
- 3.18 Dual mode TMDS Clock
- 3.19 Dual-mode EYE Diagram Testing
- 8.1 AUX Manchester Channel Eye Test
- 8.2 AUX Manchester Channel Sensitivity Test
- 8.5 AUX Inrush Test

Physical characteristics

Configuration	Description
Oscilloscope	DPO/MSO71604C or above including latest SX series oscilloscopes with Option DJA, 5XL and SDLA64 <ul style="list-style-type: none"> • 4 GHz and above is recommended for RBR • 8 GHz and above is recommended for HBR • 12.5 GHz and above is recommended for HBR2 • 16 GHz and above is recommended for HBR3
Probe	P7313SMA x 4 (for multilane testing)

Ordering information

Software Ordering Information

DP1.4 software can be ordered separately as an upgrade option for a Tektronix oscilloscope or ordered along with a new oscilloscope. Please refer to <http://www.tektronix.com/displayport> for detailed product configuration on Source and Sink testing.

Option	Description
DP14	TekExpress DP 1.4 Conformance Automation Solution: Instrument License
DPOFL-DP14	TekExpress DP 1.4 Conformance Automation Solution: Floating License
DPO-UP DP14	TekExpress DP 1.4 Conformance Automation Solution: Software Upgrade
DP12/DPOFL-DP12/DPOFT-DP12	TekExpress DP 1.2 Conformance Automation Solution for backward compatibility testing
SWX-DP/DPOFL-SWX-DP/DPOFT-SWX-DP	Switch Matrix option for DisplayPort testing
SDLA64	Serial Data Link Analysis for Win7 (64 bit) Oscilloscopes

Recommended Fixture and Accessories for DisplayPort Testing

Option	Description
TF-DP-TPA-P	Standard DisplayPort Plug fixture
DP-TPA-A	DisplayPort Aux Control Adapter from Wilder Tech
DPR-100	DisplayPort Reference Sink Aux Controller from Unigraf
GRL-USB-PD-C1	Type-C Power Delivery Controller from Granite River Labs
DP-TPC-PCB	Type-C Plug and Control Board from Wilder Tech
TBTCAMT-TPA-P	Tektronix pre-compliance Type-C fixture
PSPL5501A (or equivalent DC Block) (4 n.o)	Recommended DC Block for DP Type-C testing

Prerequisite Host System Software Requirements for DisplayPort Testing

Operating System	Windows 7 64 bit
Software	<ul style="list-style-type: none"> • Microsoft Internet Explorer 7.0 SP1 or later • Adobe Reader 7.0 or equivalent software for viewing Portable Document Format (PDF) file • Microsoft Excel 2007 or equivalent software for viewing Comma-separated Value (CSV) file

For more information about DisplayPort testing, visit our website <http://www.tek.com/displayport-0>

Recommended software and equipment for DisplayPort Sink Test Automation

Recommended equipment and software

Equipment / software	Description
Stressed signal generator	BERTScope BSX125
Oscilloscope	DPO/MSO 71254C/DX (or above) with DPOJET option DJA and SDLA64 for creating CTLE filters
Automation software	Option TEK-GRL-DP-SINKSW

Recommended accessories

Accessories	Description
Aux controller	Unigraf DPR-200 (for DUT automation)
Matched pair cables	5 pairs, Tektronix part number: 174-4944-xx
ISI Generator	Artek CLE1000-A2
Fixture	F-DP-TPA-PR, plug and receptacle fixture
DC blocks	2 each; 20 GHz DC Block
Divide by 3 splitter	2 each; JFW 50PD-292 or equivalent
150 ps TTC filters	2 each

ASEAN / Australasia (65) 6356 3900
Belgium 00800 2255 4835*
Central East Europe and the Baltics +41 52 675 3777
Finland +41 52 675 3777
Hong Kong 400 820 5835
Japan 81 (3) 6714 3086
Middle East, Asia, and North Africa +41 52 675 3777
People's Republic of China 400 820 5835
Republic of Korea +822 6917 5084, 822 6917 5080
Spain 00800 2255 4835*
Taiwan 886 (2) 2656 6688

Austria 00800 2255 4835*
Brazil +55 (11) 3759 7627
Central Europe & Greece +41 52 675 3777
France 00800 2255 4835*
India 000 800 650 1835
Luxembourg +41 52 675 3777
The Netherlands 00800 2255 4835*
Poland +41 52 675 3777
Russia & CIS +7 (495) 6647564
Sweden 00800 2255 4835*
United Kingdom & Ireland 00800 2255 4835*

Balkans, Israel, South Africa and other ISE Countries +41 52 675 3777
Canada 1 800 833 9200
Denmark +45 80 88 1401
Germany 00800 2255 4835*
Italy 00800 2255 4835*
Mexico, Central/South America & Caribbean 52 (55) 56 04 50 90
Norway 800 16098
Portugal 80 08 12370
South Africa +41 52 675 3777
Switzerland 00800 2255 4835*
USA 1 800 833 9200

* European toll-free number. If not accessible, call: +41 52 675 3777

For Further Information. Tektronix maintains a comprehensive, constantly expanding collection of application notes, technical briefs and other resources to help engineers working on the cutting edge of technology. Please visit www.tek.com.

Copyright © Tektronix, Inc. All rights reserved. Tektronix products are covered by U.S. and foreign patents, issued and pending. Information in this publication supersedes that in all previously published material. Specification and price change privileges reserved. TEKTRONIX and TEK are registered trademarks of Tektronix, Inc. All other trade names referenced are the service marks, trademarks, or registered trademarks of their respective companies.

