

## Series 2400 SourceMeter® SMU Instruments

### DATASHEET



Keithley's Series 2400 Source Measure Unit (SMU) Instruments are designed specifically for test applications that demand tightly coupled sourcing and measurement. All SourceMeter models provide precision voltage and current sourcing as well as measurement capabilities. Each SourceMeter SMU instrument is both a highly stable DC power source and a true instrument-grade 6½-digit multimeter. The power source characteristics include low noise, precision, and readback. The multimeter capabilities include high repeatability and low noise. The result is a compact, single-channel, DC parametric tester. In operation, these instruments can act as a voltage source, a current source, a voltage meter, a current meter, and an ohmmeter. Manufacturers of components and modules for the communications, semiconductor, computer, automotive, and medical industries will find the SourceMeter SMU instruments invaluable for a wide range of characterization and production test applications.

### Key Features

- Five instruments in one (IV Source, IVR Measure)
- Three models: 20 W, 1100 V to 1 µV, 1 A to 10 pA
- Source and sink (4-quadrant) operation
- 0.012% basic measure accuracy with 6½-digit resolution
- 2-, 4-, and 6-wire remote V-source and measure sensing
- 1700 readings/second at 4½ digits via GPIB
- Pass/Fail comparator for fast sorting/binning
- Programmable DIO port for automation/handler/prober control (except 2401)
- Standard SCPI GPIB, RS-232 and Keithley Trigger Link interfaces
- Download KickStart today and try it out for 30 days.

### Advantages of a Tightly Integrated Instrument

By linking source and measurement circuitry in a single unit, these instruments offer a variety of advantages over systems configured with separate source and measurement instruments. For example, they minimize the time required for test station development, setup, and maintenance, while lowering the overall cost of system ownership. They simplify the test process itself by eliminating many of the complex synchronization and connection issues associated with using multiple instruments. And, their compact half-rack size conserves precious "real estate" in the test rack or bench.

### Legacy Products and Suggested Alternatives

The 2400, 2410, 2420, and 2440 SourceMeter SMU Instruments are classified as Legacy Products. They have been succeeded by Keithley's newer 2400 Series Graphical SourceMeter SMUs with improved and greater performance. For new applications and designs, Keithley recommends you consider using the newer graphical models. The table provides a list of suggested graphical models for new applications and designs.

Legacy Model	Model Type	Graphical Model
2400	Basic/ Standard	2450
2410	High Voltage	2470
2420*	High Current	2460 or 2461
2440*	High Current	2460 or 2461

\* No longer available.

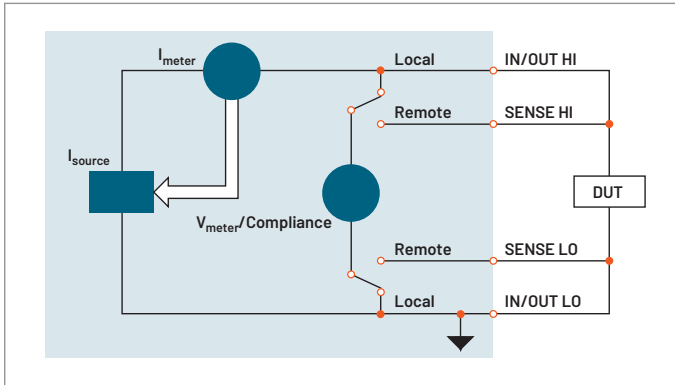

Source I-Measure V, I, or  $\Omega$  configuration

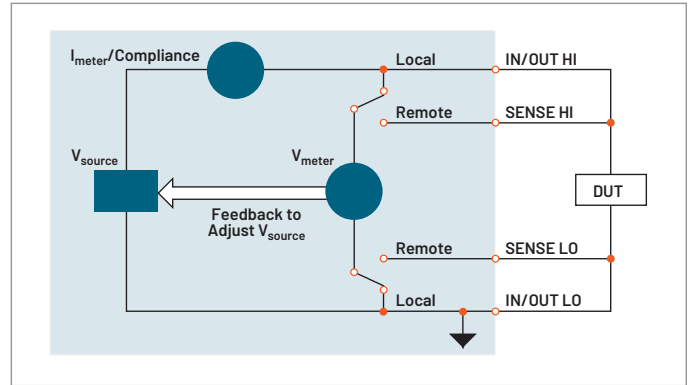

Source V-Measure I, V, or  $\Omega$  configuration

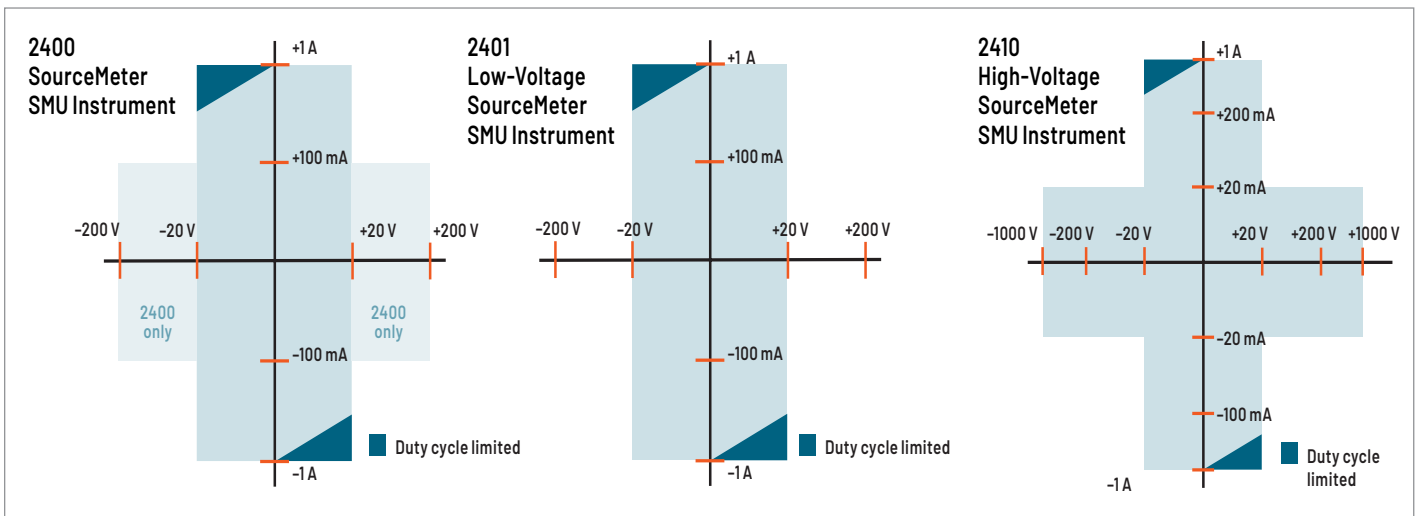

Series 2400 SourceMeter SMU Instruments

## Typical Applications

### Devices

- Discrete semiconductor devices
- Passive devices
- Transient suppression devices
- ICs, RFICs, MMICs
- Laser diodes, laser diode modules, LEDs, photodetectors
- Circuit protection devices: TVS, MOV, Fuses, etc.
- Airbags
- Connectors, switches, relays
- High brightness LEDs (DC and pulse)

### Tests

- Leakage
- Low voltage/resistances
- LIV
- IDDQ
- I-V characterization
- Isolation and trace resistance
- Temperature coefficient
- Forward voltage, reverse breakdown, leakage current
- DC parametric test
- DC power source
- HIPOT
- Photovoltaic cell efficiency (source and sink)
- Dielectric withstanding

## Power of Five Instruments in One (IV Source, IVR Measure)

The tightly coupled nature of a SourceMeter SMU instrument provides many advantages over solutions configured from separate instruments, such as a precision power supply and a digital multimeter. For example, it provides faster test times by reducing GPIB traffic and simplifies the remote programming interface. It also protects the device under test from damage due to accidental overloads, thermal runaway, etc. Both the current and voltage source are programmable with readback to help maximize device measurement integrity. If the readback reaches a programmed compliance limit, then the source is clamped at the limit, providing fault protection.

## I-V Characteristics

All SourceMeter SMU instruments provide four-quadrant operation. In the first and third quadrants they operate as a source, delivering power to a load. In the second and fourth quadrants they operate as a sink, dissipating power internally. Voltage, current, and resistance can be measured during source or sink operation.

## Automation for Speed

A SourceMeter SMU instrument streamlines production testing. It sources voltage or current while making measurements without needing to change connections. It is designed for reliable operation in non-stop production environments. To provide the throughput demanded by production applications, the SourceMeter SMU instrument offers many built-in features that allow it to run complex test sequences without computer control or GPIB communications slowing things down.

## Standard and Custom Sweeps

Sweep solutions greatly accelerate testing with automation hooks. Three basic sweep waveforms are provided that can be programmed for single-event or continuous operation. They are ideal for I/V, I/R, V/I, and V/R characterization.

- Linear Staircase Sweep: Moves from the start level to the stop level in equal linear steps
- Logarithmic Staircase Sweep: Done on a log scale with a specified number of steps per decade
- Custom Sweep: Allows construction of special sweeps by specifying the number of measurement points and the source level at each point
- Up to 1700 readings/second at 4½ digits to the GPIB bus
- 5000 readings can be stored in the non-volatile buffer memory

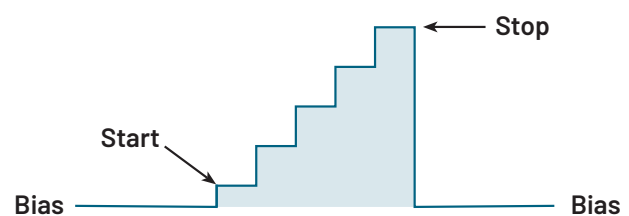

**Linear staircase sweep**

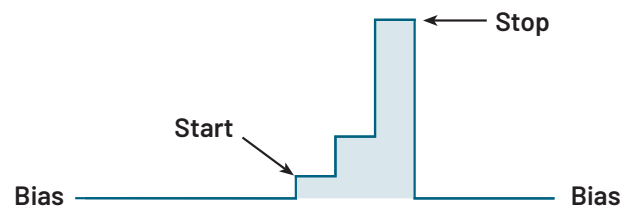

**Logarithmic staircase sweep**

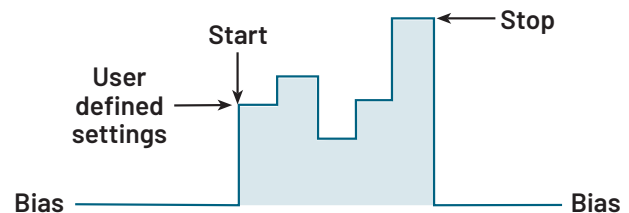

**Custom sweep**

## Built-In Test Sequencer (Source Memory List)

The Source Memory list provides faster and easier testing by allowing you to set up and execute up to 100 different tests that run without PC intervention.

- Stores up to 100 instrument configurations, each containing source settings, measurement settings, pass/fail criteria, etc.
- Pass/fail limit test as fast as 500  $\mu$ s per point
- Onboard comparator eliminates the delay caused when sending data to the computer for analysis
- Built-in, user definable math functions to calculate derived parameters

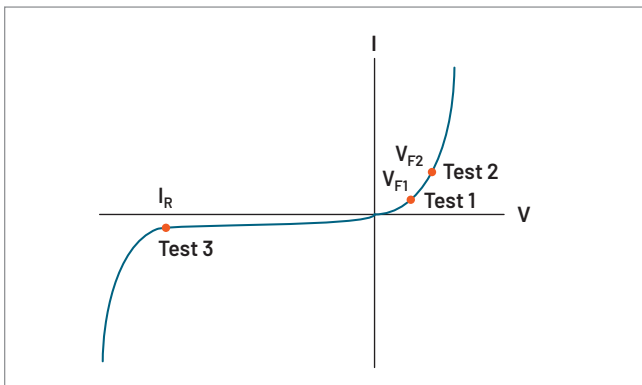

Test	Pass/Fail Test	If Passes Test	If Fails Test
Test 1	Check $V_{F1}$ at 100 mA against pass/fail limits	Go to Test 2	1. Bin part to bad bin 2. Transmit data to computer while handler is placing new part 3. Return to Test 1
Test 2	Check $V_{F2}$ at 1 A against pass/fail limits	Go to Test 3	
Test 3	Check leakage current at -500 V and test against pass/fail limits	1. Bin part to good bin 2. Transmit readings to computer while handler is placing new part 3. Return to Test 1	

Example test sequence

## Digital I/O Interface

The digital I/O interface can link a SourceMeter SMU instrument to many popular component handlers, including Aetrium, Aeco, and Robotronics. Other capabilities of the interface include:

- Tight systems integration for applications such as binning and sorting
- Built-in component handler interface
- Start of test and end of test signals
- 5 V, 300 mA power supply

The digital I/O interface is only available on the 2400 and 2410.

## Trigger Link Interface

All SourceMeter SMU instruments include Keithley’s unique Trigger Link interface, which provides high-speed, seamless communications with many of Keithley’s other instruments independent of a computer and GPIB.

## Unique 6-Wire Ohms Technique

SourceMeter SMU instruments can make standard 4-wire, split Kelvin, and 6-wire, guarded ohms measurements and can be configured for either the constant current or constant voltage method. The 6-wire ohms technique:

- Uses guard and guard sense leads in addition to the 4-wire sense and source leads.
- Locks out parallel current paths when measuring resistor networks or hybrid circuits to isolate the component under test.
- Allows users to configure and plot data easily from Series 2400 SourceMeter SMU instruments, making characterization of two, three, and four terminal devices a snap.

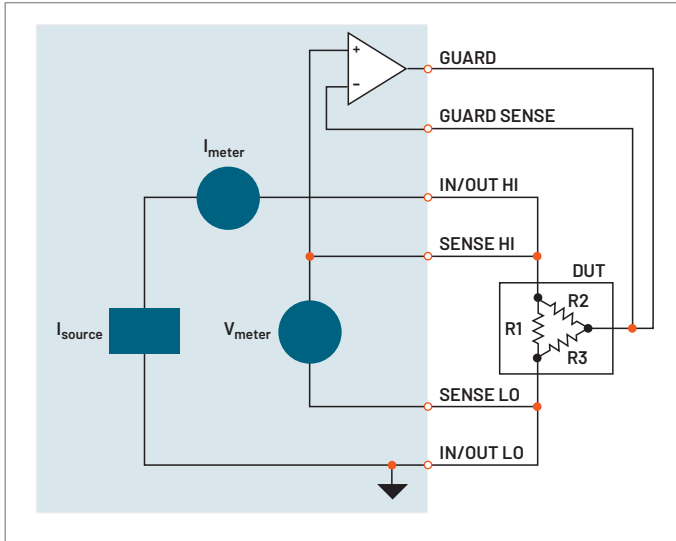

**6-Wire Ohms Circuit.** All test current flows through R1 because the high current guard drives the voltage across R2 to 0 V.

## Instrument Control Start-up Software

KickStart Software enables users to start making measurements in minutes without programming. In most cases, users merely need to make some quick measurements, graph the data, and store the data to disk for later analysis in software environments such as Excel. KickStart offers:

- Configure and control up to four SMU instruments for DC or Pulsed I-V test in either the same app, same project, or a combination of the two.
- Create tests by mixing any of these SMU instruments: 2400 Graphical Series, 2400 Standard Series (DC only), 2600B Series, 2651A, 2657A, and 6430 SourceMeter® SMU (DC only) instruments.
- Differentiate SMU instrument channels and their measurement data using labels that are relevant to your device or module.
- Native X-Y graphing, panning, and zooming; screenshot capturing of graphs.
- Spreadsheet/tabular viewing of data; export data for further analysis.
- Annotating of tests; save test setups.
- GPIB, USB 2.0, Ethernet compliance.



## Specifications

### Voltage Accuracy (Local or Remote Sense)

Model	Range	Programming Resolution	Source <sup>1</sup> Accuracy (1 Year) 23°C ±5°C ±(% rdg. + volts)	Default Measurement Resolution	Measurement <sup>2,3,4</sup> Accuracy (1 Year) 23°C ±5°C ±(% rdg. + volts)	Output Slew Rate (±30%)	Source/Sink Limit
2400, 2401	200.000 mV	5 µV	0.02% + 600 µV	1 µV	0.012% + 300 µV		±21 V @ ±1.05 A
	2.00000 V	50 µV	0.02% + 600 µV	10 µV	0.012% + 300 µV		
	20.0000 V	500 µV	0.02% + 2.4 mV	100 µV	0.015% + 1.5 mV	0.08 V/µs	±210 V @ ±105 mA*
	200.000 V*	5 mV	0.02% + 24 mV	1 mV	0.015% + 10 mV	0.5 V/µs	
2410	200.000 mV	5 µV	0.02% + 600 µV	1 µV	0.012% + 300 µV		±21 V @ ±1.05 A
	2.00000 V	50 µV	0.02% + 600 µV	10 µV	0.012% + 300 µV		
	20.0000 V	500 µV	0.02% + 2.4 mV	100 µV	0.015% + 1 mV	0.15 V/µs	±1100 V @ ±21 mA
	1000.00 V	50 mV	0.02% + 100 mV	10 mV	0.015% + 50 mV	0.5 V/µs	

\*Not available on 2401.

#### NOTES

- Specifications valid for continuous output currents below 105 mA. For operation above 105 mA continuous for >1 minute, derate accuracy 10%/35 mA above 105 mA.
- Speed = Normal (1 PLC). For 0.1 PLC, add 0.005% of range to offset specifications, except 200 mV, 1 A ranges, add 0.05%. For 0.01 PLC, add 0.05% of range to offset specifications, except 200 mV, 1 A ranges, add 0.5%.
- Accuracies apply to 2- or 4-wire mode when properly zeroed.

#### Temperature Coefficient (0° to 18°C and 28° to 50°C)

±(0.15 × accuracy specification)/°C  
**2410 only:** ±(0.15 × accuracy specification)/°C on 20 V and 1000 V ranges.  
 ±(0.30 × accuracy specification)/°C on 200 mV and 2 V ranges.

<b>Voltage Regulation</b>	<b>Line:</b> 0.01% of range. <b>Load:</b> 0.01% of range + 100 µV.
<b>Over Voltage Protection</b>	User selectable values, 5% tolerance. Factory default = none.
<b>Current Limit</b>	Bipolar current limit (compliance) set with single value. Min. 0.1% of range.
<b>Overshoot</b>	<0.1% typical (full scale step, resistive load, 10 mA range).

#### Additional Source Specifications (All Models)

<b>Transient Response Time</b>	30 µs minimum for the output to recover to its spec. following a step change in load.
<b>Command Processing Time</b>	Maximum time required for the output to begin to change following the receipt of :SOURce:VOLTage CURRent <nrf> command. <b>Autorange On:</b> 10 ms. <b>Autorange Off:</b> 7 ms.
<b>Output Settling Time</b>	Time required to reach 0.1% of final value after command is processed. 100 µs typical. Resistive load. 10 µA to 100 mA range.
<b>DC Floating Voltage</b>	Output can be floated up to ±250 VDC from chassis ground.
<b>Remote Sense</b>	Up to 1V drop per load lead.
<b>Compliance Accuracy</b>	Add 0.3% of range and ±0.02% of reading to base specification.
<b>Over Temperature Protection</b>	Internally sensed temperature overload puts unit in standby mode.
<b>Range Change Overshoot</b>	Overshoot into a fully resistive 100 kΩ load, 10 Hz to 1 MHz BW, adjacent ranges: 100 mV typical, except 20 V/200 V and range boundary.
<b>Minimum Compliance Value</b>	0.1% of range.

## Current Accuracy (Local or Remote Sense)

Model	Range	Programming Resolution	Source <sup>1,3</sup> Accuracy (1 Year) 23°C ±5°C ±(% rdg. + amps)	Default Measurement Resolution	Measurement <sup>4,5</sup> Accuracy (1 Year) 23°C ±5°C ±(% rdg. + amps)	Source/Sink Limit	
2400, 2401	1.00000 µA	50 pA	0.035% + 600 pA	10 pA	0.029% + 300 pA	±1.05 A @ ±21 V	
	10.0000 µA	500 pA	0.033% + 2 nA	100 pA	0.027% + 700 pA		
	100.000 µA	5 nA	0.031% + 20 nA	1 nA	0.025% + 6 nA		
	2400, 2401	1.00000 mA	50 nA	0.034% + 200 nA	10 nA	0.027% + 60 nA	±105 mA @ ±210 V <sup>6</sup>
		10.0000 mA	500 nA	0.045% + 2 µA	100 nA	0.035% + 600 nA	
		100.000 mA	5 µA	0.066% + 20 µA	1 µA	0.055% + 6 µA	
		1.00000 A <sup>2</sup>	50 µA	0.27 % + 900 µA	10 µA	0.22 % + 570 µA	
2410	1.00000 µA	50 pA	0.035% + 600 pA	10 pA	0.029% + 300 pA	±1.05 A @ ±21 V	
	10.0000 µA	500 pA	0.033% + 2 nA	100 pA	0.027% + 700 pA		
	100.000 µA	5 nA	0.031% + 20 nA	1 nA	0.025% + 6 nA		
	2410	1.00000 mA	50 nA	0.034% + 200 nA	10 nA	0.027% + 60 nA	±21 mA @ ±1100 V
		20.0000 mA	500 nA	0.045% + 4 µA	100 nA	0.035% + 1.2 µA	
		100.000 mA	5 µA	0.066% + 20 µA	1 µA	0.055% + 6 µA	
		1.00000 A <sup>2</sup>	50 µA	0.27 % + 900 µA	10 µA	0.22 % + 570 µA	

## NOTES

- Specifications valid for continuous output currents below 105 mA. For operation above 105 mA continuous for >1 minute, derate accuracy 10%/35 mA above 105 mA.
- Full operation (1 A) regardless of load to 30°C. Above 30°C ambient, derate 35 mA/°C and prorate 35 mA/Ω load. 4-wire mode. For current sink operation on 1 A range, maximum continuous power is limited to approximately ½ rated power or less, depending on current, up to 30°C ambient. See power equations in the User Manual to calculate allowable duty cycle for specific conditions.
- For sink mode, 1 µA to 100 mA range, accuracy is: **2400, 2401:** ±(0.15% + offset\*4). **2410:** ±(0.5% + offset\*3). For 1 A range, accuracy is: **2400, 2401:** ±(1.5% + offset\*8). **2410:** ±(0.15% accuracy specification)/°C on 20 V and 1000 V ranges ±(1.5% + offset\*3).
- Speed = Normal (1 PLC). For 0.1 PLC, add 0.005% of range to offset specifications, except 200 mV, 1 A ranges, add 0.05%. For 0.01 PLC, add 0.05% of range to offset specifications, except 200 mV, 1 A, ranges, add 0.5%.
- Accuracies apply to 2- or 4-wire mode when properly zeroed.
- 2400 only.

## Temperature Coefficient (0° to 18°C and 28° to 50°C)

$$\pm(0.15 \times \text{accuracy specification})/^{\circ}\text{C}.$$

## Current Regulation

**Line:** 0.01% of range. **Load:** 0.01% of range + 100 pA.

## Voltage Limit

Bipolar voltage limit (compliance) set with single value. Minimum 0.1% of range.

## Overshoot

<0.1% typical (1 mA step, RL = 10 kΩ, 20 V range).

Resistance Measurement Accuracy (Local or Remote Sense)<sup>1,2</sup>

Range	Default Resolution	Default Test Current	Normal Accuracy (18°C to 28°C) 1 Year, ±(% rdg. + ohms)		Enhanced Accuracy (18°C to 28°C) <sup>4</sup> 1 Year, ±(% rdg. + ohms)
			2400, 2401	2410	2400, 2401
<0.20000 Ω <sup>3</sup>	—	—	Source I <sub>ACC</sub> + Meas. V <sub>ACC</sub>	Source I <sub>ACC</sub> + Meas. V <sub>ACC</sub>	Source I <sub>ACC</sub> + Meas. V <sub>ACC</sub>
2.00000 Ω <sup>3</sup>	10 μΩ	—	Source I <sub>ACC</sub> + Meas. V <sub>ACC</sub>	Source I <sub>ACC</sub> + Meas. V <sub>ACC</sub>	Source I <sub>ACC</sub> + Meas. V <sub>ACC</sub>
20.0000 Ω	100 μΩ	100 mA	0.10% + 0.003 Ω	0.11% + 0.006 Ω	0.07% + 0.001 Ω
200.000 Ω	1 mΩ	10 mA	0.08% + 0.03 Ω	0.09% + 0.1 Ω	0.05% + 0.01 Ω
2.00000 kΩ	10 mΩ	1 mA	0.07% + 0.3 Ω	0.08% + 0.6 Ω	0.05% + 0.1 Ω
20.0000 kΩ	100 mΩ	100 μA	0.06% + 3 Ω	0.07% + 6 Ω	0.04% + 1 Ω
200.000 kΩ	1 Ω	10 μA	0.07% + 30 Ω	0.07% + 60 Ω	0.05% + 10 Ω
2.00000 MΩ	10 Ω	1 μA	0.11% + 300 Ω	0.12% + 600 Ω	0.05% + 100 Ω
20.0000 MΩ	100 Ω	1 μA	0.11% + 1 kΩ	0.12% + 2.4 kΩ	0.05% + 500 Ω
200.000 MΩ <sup>3</sup>	1 kΩ	100 nA	0.66% + 10 kΩ	0.66% + 24 kΩ	0.35% + 5 kΩ
>200.000 MΩ <sup>3</sup>	—	—	Source I <sub>ACC</sub> + Meas. V <sub>ACC</sub>	Source I <sub>ACC</sub> + Meas. V <sub>ACC</sub>	Source I <sub>ACC</sub> + Meas. V <sub>ACC</sub>

**Temperature Coefficient (0° to 18°C and 28° to 50°C)**

±(0.15 × accuracy specification)/°C.

**Source I Mode, Manual Ohms**

Total uncertainty = I source accuracy + V measure accuracy (4-wire remote sense).

**Source V Mode, Manual Ohms**

Total uncertainty = V source accuracy + I measure accuracy (4-wire remote sense).

**6-wire Ohms Mode**

Available using active ohms guard and guard sense. Max. Guard Output Current: 50 mA (except 1 A range). Accuracy is load dependent. Refer to White Paper below for calculation formula:  
[Obtaining More Accurate Resistance Measurements Using the 6-wire Ohms Measurement Technique.](#)

**Guard Output Impedance**

&lt;0.1 Ω in ohms mode.

**NOTES**

- Speed = Normal (1 PLC). For 0.1 PLC, add 0.005% of range to offset specifications, except 200 mV, 1 A ranges, add 0.05%. For 0.01 PLC, add 0.05% of range to offset specifications, except 200 mV, 1 A ranges, add 0.5%.
- Accuracies apply to 2- or 4-wire mode when properly zeroed.
- Manual ohms only except for 200 MΩ range.
- Source readback enabled, offset compensation ON. Also available on 2410 with similar accuracy enhancement.

## System Speeds

### Measurement<sup>1</sup>

**Maximum Range Change Rate** 75/second.

**Maximum Measure Autorange Time** 40 ms (fixed source).<sup>2</sup>

### Sweep Operation<sup>3</sup> Reading Rates (rdg./second) for 60 Hz (50 Hz)

Speed	NPLC/ Trigger Origin	Measure				Source-Measure				Source-Measure <sup>5</sup> Pass/Fail Test <sup>4,5</sup>				Source-Memory <sup>4</sup>			
		To Mem.		To GPIB		To Mem.		To GPIB		To Mem.		To GPIB		To Mem.		To GPIB	
<b>Fast</b>	0.01 / internal	2081	(2030)	1754		1551	(1515)	1369		902	(900)	981		165	(162)	165	
<b>IEEE-488.1 Mode</b>	0.01 / external	1239	(1200)	1254		1018	(990)	1035		830	(830)	886		163	(160)	163	
<b>Fast</b>	0.01 / internal	2081	(2030)	1198	(1210)	1551	(1515)	1000	(900)	902	(900)	809	(840)	165	(162)	164	(162)
<b>IEEE-488.2 Mode</b>	0.01 / external	1239	(1200)	1079	(1050)	1018	(990)	916	(835)	830	(830)	756	(780)	163	(160)	162	(160)
<b>Medium</b>	0.10 / internal	510	(433)	509	(433)	470	(405)	470	(410)	389	(343)	388	(343)	133	(126)	132	(126)
<b>IEEE-488.2 Mode</b>	0.10 / external	438	(380)	438	(380)	409	(360)	409	(365)	374	(333)	374	(333)	131	(125)	131	(125)
<b>Normal</b>	1.00 / internal	59	(49)	59	(49)	58	(48)	58	(48)	56	(47)	56	(47)	44	(38)	44	(38)
<b>IEEE-488.2 Mode</b>	1.00 / external	57	(48)	57	(48)	57	(48)	57	(47)	56	(47)	56	(47)	44	(38)	44	(38)

### Single Reading Operation Reading Rates (rdg./second) for 60 Hz (50 Hz)

Speed	NPLC/Trigger Origin	Measure To GPIB		Source-Measure <sup>5</sup> To GPIB		Source-Measure Pass/Fail Test <sup>4,5</sup> To GPIB	
<b>Fast (488.1)</b>	0.01 / internal	537		140		135	
<b>Fast (488.2)</b>	0.01 / internal	256	(256)	79	(83)	79	(83)
<b>Medium (488.2)</b>	0.10 / internal	167	(166)	72	(70)	69	(70)
<b>Normal (488.2)</b>	1.00 / internal	49	(42)	34	(31)	35	(30)

### Component for 60 Hz (50 Hz)<sup>4,6</sup>

Speed	NPLC/Trigger Origin	Measure To GPIB		Source Pass/Fail Test		Source-Measure Pass/Fail Test <sup>5,7</sup> To GPIB	
<b>Fast</b>	0.01 / external	1.04 ms	(1.08 ms)	0.5 ms	(0.5 ms)	4.82 ms	(5.3 ms)
<b>Medium</b>	0.10 / external	2.55 ms	(2.9 ms)	0.5 ms	(0.5 ms)	6.27 ms	(7.1 ms)
<b>Normal</b>	1.00 / external	17.53 ms	(20.9 ms)	0.5 ms	(0.5 ms)	21.31 ms	(25.0 ms)

### NOTES

1. Reading rates applicable for voltage or current measurements. Auto zero off, autorange off, filter off, display off, trigger delay = 0, and binary reading format.
2. Purely resistive load. 1  $\mu$ A and 10  $\mu$ A ranges <65 ms.
3. 1000 point sweep was characterized with the source on a fixed range.
4. Pass/Fail test performed using one high limit and one low math limit.
5. Includes time to re-program source to a new level before making measurement.
6. Time from falling edge of START OF TEST signal to falling edge of end of test signal.
7. Command processing time of :SOURCE:VOLTage|CURRENT:TRIGgered <nrf> command not included.

## General Specifications

### Noise Rejection

	NPLC	NMRR	CMRR
Fast	0.01	–	80 dB
Medium	0.1	–	80 dB
Slow	1	60 dB	100 dB <sup>1</sup>

<sup>1</sup>Except lowest 2 current ranges = 90 dB.

<b>Load Impedance</b>	Stable into 20,000 pF typical.
<b>Common Mode Voltage</b>	250 V DC.
<b>Common Mode Isolation</b>	>10 <sup>9</sup> Ω, <1000 pF.
<b>Overrange</b>	105% of range, source and measure.
<b>Max. Voltage Drop Between Input/Output and Sense Terminals</b>	5 V.
<b>Max. Sense Lead Resistance</b>	1 MΩ for rated accuracy.
<b>Sense Input Impedance</b>	>10 <sup>10</sup> Ω.
<b>Guard Offset Voltage</b>	<150 μV, typical.
<b>Source Output Modes</b>	Fixed DC level Memory List (mixed function) Stair (linear and log)
<b>Memory Buffer</b>	5,000 readings @ 5 digits (two 2,500 point buffers). Includes selected measured value(s) and time stamp. Lithium battery backup (3 yr+ battery life).
<b>Source Memory List</b>	100 points maximum.
<b>Programmability</b>	IEEE-488 (SCPI-1995.0), RS-232, 5 user-definable power-up states plus factory default and *RST.
<b>Digital Interface</b>	
<b>Output Enable</b>	Active low input.
<b>Handler Interface</b>	Start of test, end of test, 3 category bits. +5 V @ 300 mA supply. Not available on 2401.
<b>Digital I/O</b>	1 trigger input, 4 TTL/Relay Drive outputs (33 V @ 500 mA, diode clamped). Not available on 2401.
<b>Power Supply</b>	100 V to 240 V rms, 50–60 Hz (automatically detected at power up). <b>2400, 2401:</b> 190 VA. <b>2410:</b> 210 VA.
<b>Cooling</b>	<b>2400, 2401:</b> Convection. <b>2410:</b> Forced air, variable speed.
<b>EMC</b>	Conforms to European Union Directive.
<b>Safety</b>	Conforms to European Union Low Voltage Directive. 2400 and 2401 UL listed to UL 61010-1:2012 and UL 61010-2-30:2012.
<b>Vibration</b>	MIL-PRF-28800F Class 3 Random.
<b>Warm-Up</b>	1 hour to rated accuracies.
<b>Dimensions</b>	89 mm high × 213 mm wide × 370 mm deep (3½ in × 8⅜ in × 14 <sup>9</sup> / <sub>16</sub> in). <b>Bench Configuration (with handle and feet):</b> 104 mm high × 238 mm wide × 370 mm deep (4⅛ in × 9⅜ in × 14 <sup>9</sup> / <sub>16</sub> in).
<b>Weight</b>	3.21 kg (7.08 lbs.).
<b>Environment</b>	For indoor, non-residential use only. <b>Operating:</b> 0° to 50°C, 70% relative humidity up to 35°C. Derate 3% relative humidity/°C, 35° to 50°C. <b>Storage:</b> -25°C to 65°C.

## Supplied Accessories

### Test Leads

<b>LabVIEW Driver</b>	Software Driver (downloadable)
-----------------------	--------------------------------

## Available Accessories

### Test Leads and Probes

1754	2-Wire Universal 10-Piece Test Lead Kit
5804	Kelvin (4-Wire) Universal 10-Piece Test Lead Kit
5805	Kelvin (4-Wire) Spring-Loaded Probes
5808	Low Cost Single-pin Kelvin Probe Set

### Cables/Adapters

7007-1	Shielded GPIB Cable, 1 m (3.3 ft)
8620	Shorting Plug

### Communication Interface

KPCI-488LPA	IEEE-488 Interface/Controller for the PCI Bus
KUSB-488B	IEEE-488 USB-to-GPIB Interface Adapter

### Triggering and Control

8501-1	Trigger Link Cable, DIN-to-DIN, 1m (3.3 ft)
8503	Trigger Link Cable, DIN-to-Dual BNC, 1m (3.3 ft)

### Rack Mount Kits

4288-1	Single Fixed Rack Mount Kit
4288-2	Dual Fixed Rack Mount Kit
4299-3	Universal Single Unit Rack Mount Kit

## Available Services

### Extended Warranties

2400-3Y-EW	1-year factory warranty extended to 3 years from date of shipment
2401-3Y-EW	1-year factory warranty extended to 3 years from date of shipment
2410-3Y-EW	1-year factory warranty extended to 3 years from date of shipment

### Calibration Contracts

C/2400-3Y-ISO	3 (ISO-17025 accredited) calibrations within 3 years of purchase for 2400, 2400-LV*
C/2401-3Y-ISO	3 (ISO-17025 accredited) calibrations within 3 years of purchase for 2401*
C/2410-3Y-ISO	3 (ISO-17025 accredited) calibrations within 3 years of purchase for 2410*
TRN-2400-1-C	Course: Unleashing the Power of Your SourceMeter SMU Instrument

\*Not available in all countries

## Ordering Information

---

2400	200 V, 1 A, 20 W SourceMeter SMU Instrument
2401	20 V, 1 A, 20 W SourceMeter SMU Instrument
2410	1100 V, 1 A, 20 W SourceMeter SMU Instrument

---

## Warranty Information

---

<b>Warranty Summary</b>	This section summarizes the warranties of the Series 2400. For complete warranty information, refer to the Tektronix Terms and Conditions page at <a href="http://tek.com/terms_and_conditions">tek.com/terms_and_conditions</a> . Any portion of the product that is not manufactured by Keithley is not covered by this warranty and Keithley will have no duty to enforce any other manufacturer's warranties. Hardware Warranty Keithley Instruments, Inc. warrants the Keithley manufactured portion of the hardware for a period of one year from defects in materials or workmanship; provided that such defect has not been caused by use of the Keithley hardware which is not in accordance with the hardware instructions. The warranty does not apply upon any modification of Keithley hardware made by the customer or operation of the hardware outside the environmental specifications.
<b>Software Warranty</b>	Keithley warrants that the Keithley produced portion of the software or firmware will conform in all material respects with the published specifications for a period of ninety (90) days; provided the software is used on the product for which it is intended in accordance with the software instructions. Keithley does not warrant that operation of the software will be uninterrupted or error-free, or that the software will be adequate for the customer's intended application. The warranty does not apply upon any modification of the software made by the customer.

---

## Contact Information:

Australia 1 800 709 465  
Austria\* 00800 2255 4835  
Balkans, Israel, South Africa and other ISE Countries +41 52 675 3777  
Belgium\* 00800 2255 4835  
Brazil +55(11) 3530-8901  
Canada 1 800 833 9200  
Central East Europe / Baltics +41 52 675 3777  
Central Europe / Greece +41 52 675 3777  
Denmark +45 80 88 1401  
Finland +41 52 675 3777  
France\* 00800 2255 4835  
Germany\* 00800 2255 4835  
Hong Kong 400 820 5835  
India 000 800 650 1835  
Indonesia 007 803 601 5249  
Italy 00800 2255 4835  
Japan 81(3) 6714 3086  
Luxembourg +41 52 675 3777  
Malaysia 1 800 22 55835  
Mexico, Central/South America and Caribbean 52 (55) 88 69 35 25  
Middle East, Asia, and North Africa +41 52 675 3777  
The Netherlands\* 00800 2255 4835  
New Zealand 0800 800 238  
Norway 800 16098  
People's Republic of China 400 820 5835  
Philippines 1 800 1601 0077  
Poland +41 52 675 3777  
Portugal 80 08 12370  
Republic of Korea +82 2 565 1455  
Russia / CIS +7(495) 6647564  
Singapore 800 6011 473  
South Africa +41 52 675 3777  
Spain\* 00800 2255 4835  
Sweden\* 00800 2255 4835  
Switzerland\* 00800 2255 4835  
Taiwan 886 (2) 2656 6688  
Thailand 1 800 011 931  
United Kingdom / Ireland\* 00800 2255 4835  
USA 1 800 833 9200  
Vietnam 12060128

\*European toll-free number. If not accessible, call: +41 52 675 3777

Rev. 02.2022



Find more valuable resources at [TEK.COM](http://TEK.COM)

Copyright © Tektronix. All rights reserved. Tektronix products are covered by U.S. and foreign patents, issued and pending. Information in this publication supersedes that in all previously published material. Specification and price change privileges reserved. TEKTRONIX and TEK are registered trademarks of Tektronix, Inc. All other trade names referenced are the service marks, trademarks or registered trademarks of their respective companies.

061126 KEI 1KW-2798-5

