

# Performing Strain Gauge Measurements with the Keithley DAQ6510 Data Acquisition and Logging Multimeter System and KickStart Software

## APPLICATION NOTE

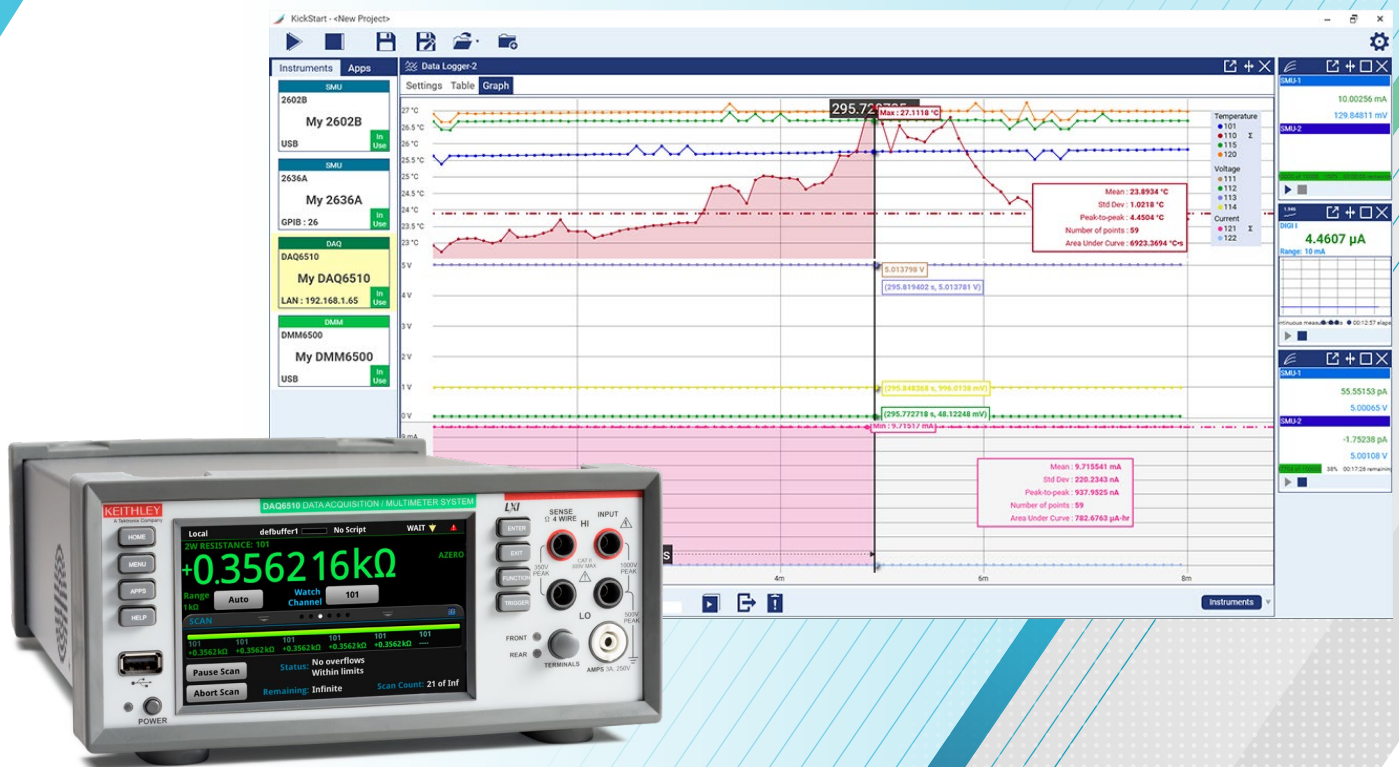

**KEITHLEY**  
A Tektronix Company

**Tektronix**

## Introduction

A strain gauge is a resistive device that is used to monitor changes in force. As the object on which the strain gauge is mounted is deformed or displaced, so too is the strain gauge, converting mechanical properties into an electrically measurable stimulus.

Strain sensors are useful in several applications:

- Studying torque measurements in electric vehicle drive systems that have a substantially higher power density compared to their combustion engine counterparts. Electric drives have higher rotational speeds, and their torque forces will increase with hauling vehicles as we see the electrification of truck types, from passenger all the way up to Class 8 (heavy duty).
- Stress analysis of building structures can lead to early detection of structural damage in buildings, possibly helping us to better understand climate change and environmental effects.
- Strain gauges can be installed on load-bearing parts used in aerospace to help determine changes during flight.
- Pressure can be monitored in railway systems to promote the warning of excess conditions, thereby assisting maintenance crews in identifying and addressing problem spots before they get out of hand.

This application note will focus on defining some basic strain measurement principals and a means for obtaining these measurements with greater ease. Moreover, we share how you can use the Keithley DAQ6510 Data Acquisition and Logging Multimeter System in concert with the KickStart software to acquire strain measurements through our proposed simplified method.

## Simplifying Strain Gauge Measurement

Strain measurements typically do not fluctuate more than a few millistrain – which is equivalent to resistance changes ranging in milliohms – and a popular means for obtaining them is to use a Wheatstone bridge configuration like the one shown in **Figure 1**. The resistors are selected such that when the values are balanced the ratio  $R_1/R_2$  will be equivalent to  $R_4/R_3$  to achieve an output voltage ( $V_O$ ) of zero. The equation for calculating  $V_O$  for the Wheatstone bridge is as follows, in this case, balanced with  $R_2 = R_3 = 100 \Omega$  and  $R_1 = R_4 = 200 \Omega$ :

$$V_O = \left[ \left( \frac{R_3}{R_3 + R_4} \right) - \left( \frac{R_2}{R_2 + R_1} \right) \right] * V_{EX}$$
$$V_O = \left[ \left( \frac{100}{100 + 200} \right) - \left( \frac{100}{100 + 200} \right) \right] * V_{EX}$$
$$V_O = \left[ \frac{1}{3} - \frac{1}{3} \right] * V_{EX} = 0 * V_{EX} = 0 V$$

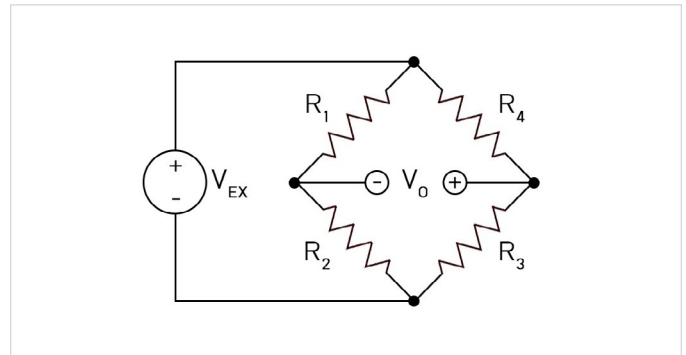

Figure 1: Wheatstone bridge configuration for use in strain measurement.

While we could go through the effort of replacing  $R_4$  in the Wheatstone bridge with a strain gauge (so that the changes in its resistance will result in non-zero values for  $V_O$ ), this setup can be complicated, requiring a voltage source, two separate voltage measurement devices, and multiple precision resistors to accurately compute a resultant strain value. Also, with so many components, it may be necessary to additionally apply some form of bridge balancing, offset nulling, or other conditioning circuitry. Instead, we will consider implementing a simpler, more cost-effective means using a precision digital multimeter (DMM) and resistance measurements applied directly to the strain gauge.

A 6½-digit DMM can provide a great deal of accuracy and resolution when measuring low-resistance devices. When values are less than 100 ohms, the four-wire (Kelvin) method can be applied to eliminate offsets due to test lead resistance. The primary disadvantage is that when numerous devices are monitored by way of a multiplexer, the number of channels required for the measurement is double that of the traditional two-wire resistance method. However, strain gauge manufacturers are producing some higher resistance device options that will better accommodate the use of the two-wire measurement and help promote greater channel availability in the switching system.

**Figure 2** shows how strain (represented as  $\epsilon$ ) may be calculated as the ratio of the change in length to the known, unstrained length.

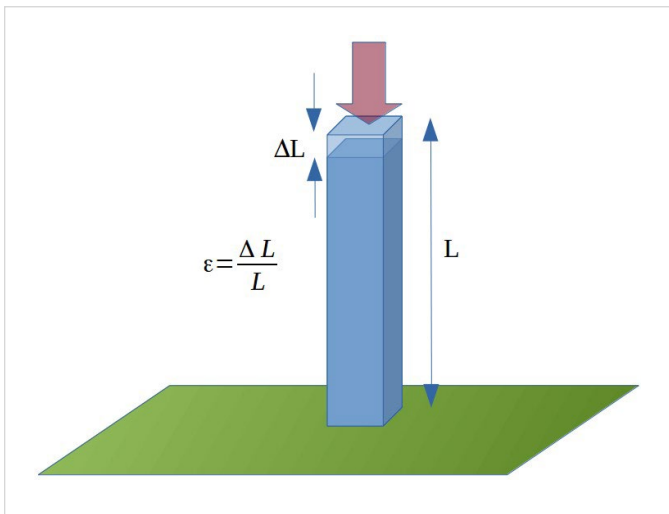

Figure 2: Strain computed from compressed device state in comparison to its quiescent state.

Manufacturers specify a gauge factor (GF) for their devices, which is an expression of the sensitivity to strain, using the formula below, where R is the resistance:

$$GF = \frac{\frac{\Delta R}{R}}{\frac{\Delta L}{L}} = \frac{\Delta R}{R} \cdot \frac{L}{\Delta L}$$

To solve for strain, the equation is converted as such:

$$\epsilon = \frac{\frac{\Delta R}{R}}{GF}$$

$$\epsilon = \Delta R * \frac{1}{GF * R}$$

Since the device’s GF is known and the quiescent state resistance can be obtained by way of a simple initial measurement, you can apply the slope intercept formula to each strained resistance measurement to help determine a strain value. For the y-intercept component ( $b$ ), we will use the negative inverse of the GF:

$$y = m * x + b$$

$$m = 1/(GF * R)$$

$$b = -1/(GF)$$

## Performing the Strain Measurement

Let us consider performing the measurement using the Keithley DAQ6510 6½-Digit Data Acquisition and Logging Multimeter System along with KickStart Software. Let’s also consider a case where you will use a pre-wired strain gauge – whose nominal, listed resistance is 350  $\Omega$  and whose GF is specified as 1.93 – connected to channel 101 of your multiplexer card.

After the DAQ6510 is connected to your PC and KickStart Software is running, open an instance of the Data Logger App and opt for the DAQ6510 as the instrument of interest.

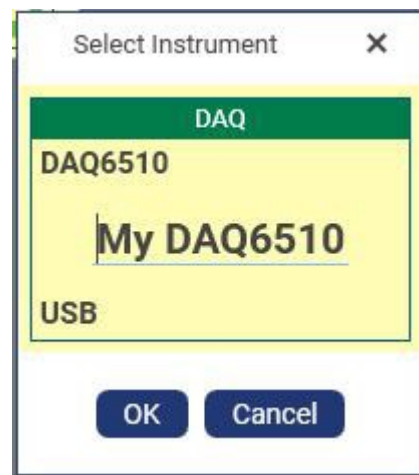

Figure 3: Launch the Data Logger app.

Choose the **2-Wire Resistance** option from the Function list control then select the channel (101) to which your strain gauge is connected. In the “Channel” group area (see **Figure 4**), click on the **Measure Now** button to obtain the strain gauge’s quiescent resistance value.



Figure 4: Measuring the device in its unstrained state will give us one of our known factors to be used in computing strain.

Using our measured value and our manufacturer-specified GF, compute the slope-intercept coefficients as:

$$m = \frac{1}{1.93 * 351.9265782} = 0.00147228$$

$$b = -\frac{1}{1.93} = -0.518135$$

Apply the check to the **Math** control to expose the options, choosing **mX+b** for the Function and applying the coefficients

calculated above to their designated input fields. Note, too, that you can apply a custom Unit to the calculation. Using your computer's numeric keypad and the **Alt+238** key combination you can generate the lower-case epsilon character that represents the strain unit.

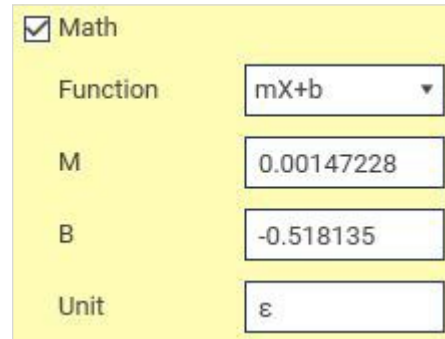

Figure 5: Applying math coefficients and user-specified units.

With the settings applied you will then click **Save Settings**.

To obtain a fast series of measurements, change the Interval Between Scans value to **0.25 s**. Click on the Run button.

In changing to the **Graph** view, you can see that, as you apply tension and compression to the surface on which the strain gauge is mounted, the plot updates as expected with the Y-axis representing the measurements at microstrain ( $\mu\epsilon$ ) levels.

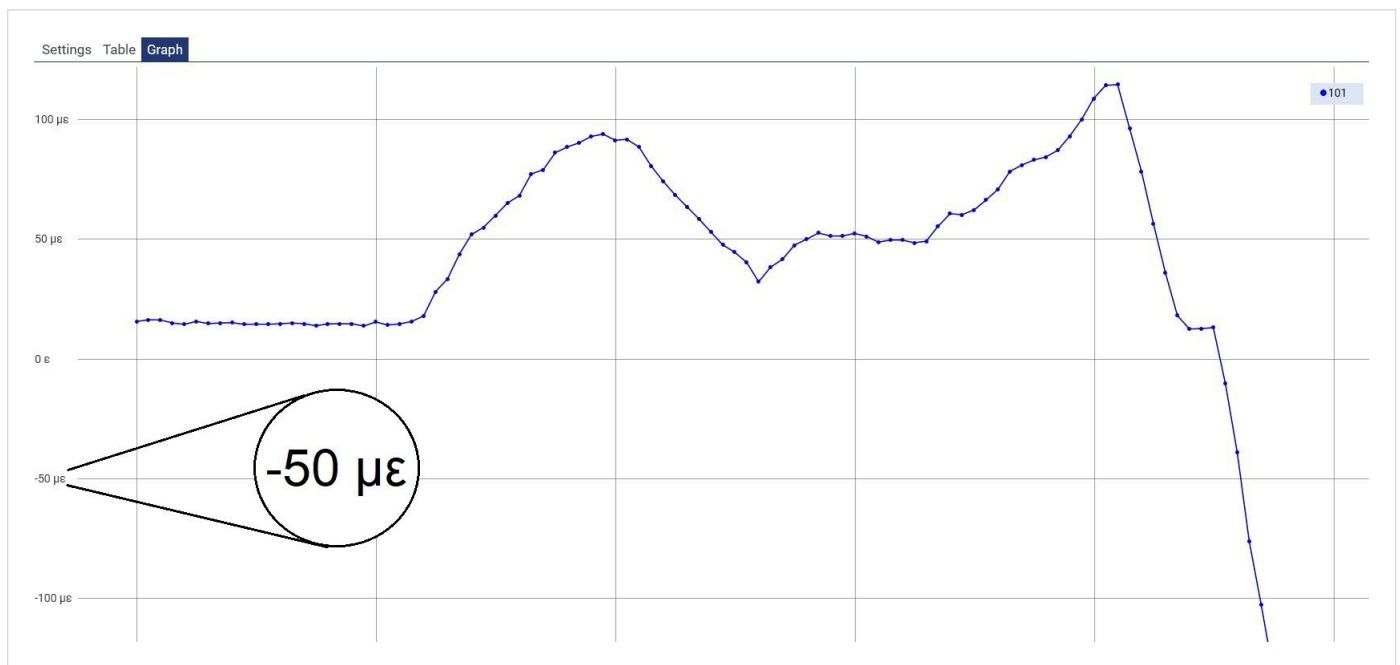

Figure 6: Graphing strain measurements.

## Summary

Keithley KickStart Software can be used to quickly automate your strain measurements by way of per-channel math functionality and the ability to apply custom units. Further, while the Keithley DAQ6510 6½-Digit Data Acquisition and Logging Multimeter System can measure micro-ohm changes in your resistive devices on up to 80 channels for two-wire devices, so too can the Keithley Series 3706A Systems Switch and Multiplexer but with increased accuracy on up to 576 channels for two-wire devices.

While the Wheatstone bridge method may be popular, direct resistance measurements made by way of a precision digital multimeter with switching capabilities can greatly simplify your setup. Four-wire resistance measurements can be used

when the strain gauge is less than 100  $\Omega$  but will require more wiring complexity and yield less channel capability with respect to switching. Two-wire resistance measurements promote greater channel bandwidth and are optimal when the strain device has a higher resistance.

For more information about four-wire versus two-wire resistance measurements, refer to the *Keithley Low Level Measurements Handbook* (section 3.3, “Low Resistance Measurements”) found on [tek.com](http://tek.com).

To learn more about the DAQ6510 and other options, visit [Keithley Switching and Data Acquisition Systems](http://tek.com/keithley-switching-and-data-acquisition-systems).

To learn more about KickStart Software apps and licensing options, visit [tek.com/keithley-kickstart](http://tek.com/keithley-kickstart).

## Contact Information:

**Australia** 1 800 709 465  
**Austria\*** 00800 2255 4835  
**Balkans, Israel, South Africa and other ISE Countries** +41 52 675 3777  
**Belgium\*** 00800 2255 4835  
**Brazil** +55 (11) 3759 7627  
**Canada** 1 800 833 9200  
**Central East Europe / Baltics** +41 52 675 3777  
**Central Europe / Greece** +41 52 675 3777  
**Denmark** +45 80 88 1401  
**Finland** +41 52 675 3777  
**France\*** 00800 2255 4835  
**Germany\*** 00800 2255 4835  
**Hong Kong** 400 820 5835  
**India** 000 800 650 1835  
**Indonesia** 007 803 601 5249  
**Italy** 00800 2255 4835  
**Japan** 81 (3) 6714 3086  
**Luxembourg** +41 52 675 3777  
**Malaysia** 1 800 22 55835  
**Mexico, Central/South America and Caribbean** 52 (55) 56 04 50 90  
**Middle East, Asia, and North Africa** +41 52 675 3777  
**The Netherlands\*** 00800 2255 4835  
**New Zealand** 0800 800 238  
**Norway** 800 16098  
**People's Republic of China** 400 820 5835  
**Philippines** 1 800 1601 0077  
**Poland** +41 52 675 3777  
**Portugal** 80 08 12370  
**Republic of Korea** +82 2 565 1455  
**Russia / CIS** +7 (495) 6647564  
**Singapore** 800 6011 473  
**South Africa** +41 52 675 3777  
**Spain\*** 00800 2255 4835  
**Sweden\*** 00800 2255 4835  
**Switzerland\*** 00800 2255 4835  
**Taiwan** 886 (2) 2656 6688  
**Thailand** 1 800 011 931  
**United Kingdom / Ireland\*** 00800 2255 4835  
**USA** 1 800 833 9200  
**Vietnam** 12060128

\* European toll-free number. If not accessible, call: +41 52 675 3777

Rev. 02.2018



Find more valuable resources at [TEK.COM](http://TEK.COM)

Copyright © Tektronix. All rights reserved. Tektronix products are covered by U.S. and foreign patents, issued and pending. Information in this publication supersedes that in all previously published material. Specification and price change privileges reserved. TEKTRONIX and TEK are registered trademarks of Tektronix, Inc. All other trade names referenced are the service marks, trademarks or registered trademarks of their respective companies.

021722 SBG 1KW-73876-0

