

Overview of Two-Wire and Four-Wire (Kelvin) Resistance Measurements

Both two-wire and four-wire resistance measurements are features of all Keithley digital multimeters (DMMs) and SourceMeter® instruments, including the Models 2110, 2100, 2000, 2001, and 2002 DMMs, the Series 2700 DMM/dataloggers, the Series 3700 DMM/switch mainframes, and the Series 2400 and 2600 SourceMeter source measurement units (SMU). This 4W measurement capability allows users to make low resistance measurements more accurately.

Two-Wire Resistance Measurements

Resistance measurements are often made using the two-wire method shown in **Figure 1**. A test current is forced through the test leads and the resistance (R) under test. The meter then measures the voltage across the resistance through the same set of test leads and computes the resistance value accordingly.

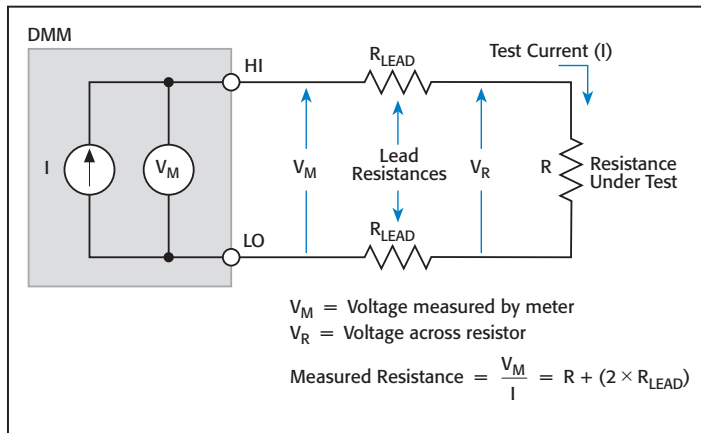

Figure 1. Setup for a typical two-wire resistance measurement.

The main measurement issue with the two-wire method, as applied to low resistance measurements, is that the total lead resistance (R_{LEAD}) is added to the measurement. Since the test current (I) causes a small but significant voltage drop across the lead resistances, the voltage (V_M) measured by the meter won't be exactly the same as the voltage (V_R) directly across the test resistance (R), and considerable error can result. Typical lead resistances lie in the range of 10mΩ to 1Ω, so it's very difficult to obtain accurate two-wire resistance measurements when the resistance under test is lower than 100Ω. For example, using test leads with a 100mΩ combined resistance to perform a two-wire resistance measurement on a 500mΩ resistor will result in a 20%

measurement error in addition to that of the instrument. See **Table 1** for another example.

Table 1: Example 2W measurement errors.

	DUT	Lead Path Resistance	% Lead-contributed Error
2 Ω	1 Ω	20 mΩ	2%
4 Ω	1 Ω	20 mΩ	<0.1%

Four-Wire (Kelvin) Resistance Measurements

Due to the limitations of the two-wire method, the four-wire (Kelvin) connection method shown in **Figure 2** is generally preferred for low resistance measurements because it reduces the effect of test lead resistance. These measurements can be made using a DMM, SourceMeter SMU instrument, or a separate current source and voltmeter. With this configuration, the test current (I) is forced through the test resistance (R) via one set of test leads, while the voltage (V_M) across the DUT is measured through a second set of leads (sense leads). Although some small current (typically less than 100pA) may flow through the sense leads, it is usually negligible and can generally be ignored for all practical purposes. The voltage drop across the sense leads is negligible, so the voltage measured by the meter (V_M) is essentially the same as the voltage (V_R) across the resistance (R). As a result, the resistance value can be determined much more accurately than with the two-wire method.

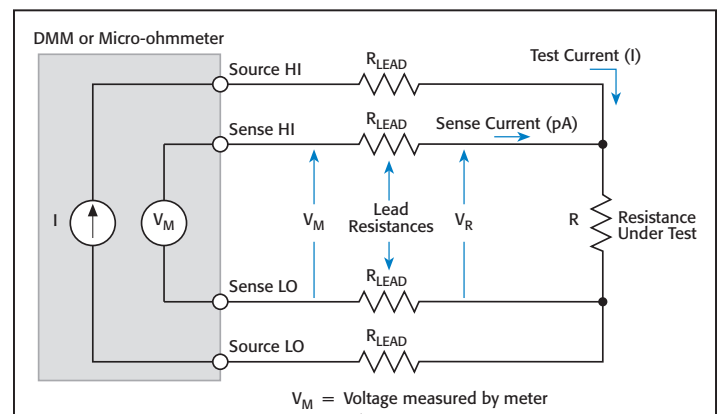

Figure 2. The effect of test lead resistance can be reduced using the four-wire (Kelvin) connection method.

Note that the voltage-sensing leads should be connected as close to the resistor under test as possible to avoid including part of the resistance of the test leads in the measurement.

Specifications are subject to change without notice. All Keithley trademarks and trade names are the property of Keithley Instruments, Inc. All other trademarks and trade names are the property of their respective companies.



KEITHLEY INSTRUMENTS, INC. ■ 28775 AURORA RD. ■ CLEVELAND, OH 44139-1891 ■ 440-248-0400 ■ Fax: 440-248-6168 ■ 1-888-KEITHLEY ■ www.keithley.com

BELGIUM

Sint-Pieters-Leeuw
Ph: 02-3630040
Fax: 02-3630064
info@keithley.nl
www.keithley.nl

CHINA

Beijing
Ph: 86-10-8447-5556
Fax: 86-10-8225-5018
china@keithley.com
www.keithley.com.cn

FRANCE

Les Ulis
Ph: 01-69868360
Fax: 01-69868361
info@keithley.fr
www.keithley.fr

GERMANY

Germering
Ph: 089-84930740
Fax: 089-84930734
info@keithley.de
www.keithley.de

INDIA

Bangalore
Ph: 080-30792600
Fax: 080-30792688
support_india@keithley.com
www.keithley.in

ITALY

Peschiera Borromeo (Mi)
Ph: 02-5538421
Fax: 02-55384228
info@keithley.it
www.keithley.it

JAPAN

Tokyo
Ph: 81-3-6714-3070
Fax: 81-3-6714-3080
info.jp@keithley.com
www.keithley.jp

KOREA

Seoul
Ph: 82-2-574-7778
Fax: 82-2-574-7838
keithley@keithley.co.kr
www.keithley.co.kr

MALAYSIA

Penang
Ph: 60-4-643-9679
Fax: 60-4-643-3794
sea@keithley.com
www.keithley.com

NETHERLANDS

Son
Ph: 040-2675502
Fax: 040-2675509
info@keithley.nl
www.keithley.nl

SINGAPORE

Singapore
Ph: 65-6747-9077
Fax: 65-6747-2991
sea@keithley.com
www.keithley.com.sg

TAIWAN

Hsinchu
Ph: 886-3-572-9077
Fax: 886-3-572-9031
info_tw@keithley.com
www.keithley.com.tw

UNITED KINGDOM

Bracknell
Ph: 044-1344-392450
Fax: 044-1344-392457
info@keithley.co.uk
www.keithley.co.uk