

where T is temperature, P is the I²R power generated, and S is degrees C/milliwatt.

Basics of Temperature Measurement: RTDs

**Dale Cigoy, Senior Applications Engineer
Keithley Instruments, Inc.**

THE most widely measured parameter is temperature. Whether in industrial applications such as the process industry or in laboratory settings, accurately measuring temperature is a critical part of success.

Temperature measurements are needed in medical applications, materials research in labs, electrical/electronic component studies, biology research, geological studies, and electrical product device characterization.

RTDs

Of the many ways to measure temperature, one of the most accurate is a resistance temperature detector, commonly referred to as an RTD. In an RTD, the resistance of the device is proportional to temperature. The most common resistive material for RTDs is platinum, with some RTDs being made from nickel or copper. RTDs have a wide range of temperatures. Depending on their construction, they can measure temperatures in the range of -270 to +850 degrees C.

RTDs require an external stimulus to function properly, usually a current source. However, this current generates heat in the resistive element, which causes an error in the temperature measurement. The measurement error is calculated by the formula

$$\Delta T = P \times S$$

Temperature Measurement Methods

There are several techniques for measuring temperature with an RTD. The first is a two-wire method. This method works by forcing current through the RTD and measuring the resulting voltage. The benefit is that it's a simple method using only two wires, making it easy to connect and implement. The main drawback is that the lead resistance is part of the measurement, which can cause some error.

An improvement on the two-wire method is the three-wire method. Here again, a current is forced through the device and a resulting voltage is measured. However, using a third wire provides compensation for the lead resistance. This requires either a three-wire compensating measurement unit or actually measuring the contribution from the third wire and subtracting it from the overall measurement.

A third technique is called the four-wire method. Like in the other two methods, a current is forced through and a voltage measured. However, the current is sourced on one set of leads while the voltage is sensed on another set of leads. The voltage is sensed at the resistive element (RTD), not at the same point as the source current. This means the test lead resistance is completely out of the measurement path. In other words, the test lead resistance is not a part of the measurement.

For example, if the test lead resistance

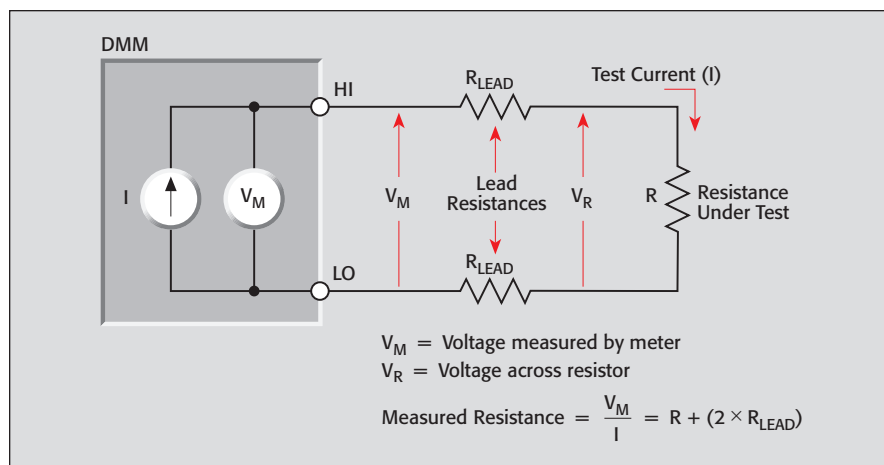

Figure 1. A schematic diagram shows the setup for a typical two-wire resistance measurement.

was about 100mΩ and the RTD was a 100Ω RTD, then the test lead resistance would be about 0.1% of error. In the four-wire method, the test lead resistance is not part of the measurement. Therefore, it is a much more accurate technique for measuring the resistance of the RTD, because it completely eliminates the lead resistance.

Pros and Cons

RTDs have some distinct advantages over other temperature-measuring devices. For one, they are the most stable and most accurate of all the different devices. Plus, they are more linear than thermocouples.

There are a few drawbacks, however. RTDs are more expensive than thermistors and thermocouples. Also, they require a current source. They have a small ΔR , which means there is a low resistance to temperature change. For example, to change one degree C, the RTD might change by 0.1Ω. However, low absolute resistance could lead to measurement errors if using the two wire method, and there is the self heating that needs to be compensated.

When using RTDs, there are several common mistakes that are often unaccounted for, the biggest of which is self-heating. If the RTD self heats with the test current,

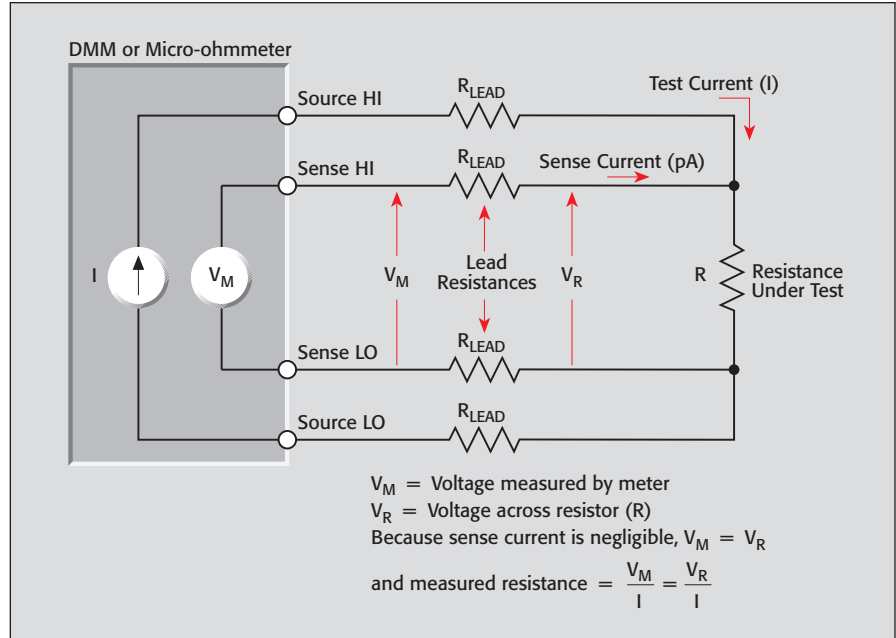

Figure 2. A typical four-wire resistance measurement setup helps eliminate much of the noise and uncertainty in temperature measurements.

this could lead to measurement inaccuracy. If measuring low temperature (e.g. below 0°C), the heat from the RTD could raise the expected temperature. Also, if the test leads are not compensated for, then even more error could be introduced into the measurement. Using a four wire method helps

eliminate this type of error. Another mistake is not selecting the proper RTD temperature range. Trying to measure outside of the RTD temperature range would result in more errors or even sensor damage. Always select the appropriate type of RTD for the expected measurement. [KEITHLEY](#)

Specifications are subject to change without notice.

All Keithley trademarks and trade names are the property of Keithley Instruments, Inc. All other trademarks and trade names are the property of their respective companies.



Keithley Instruments, Inc.

28775 Aurora Road • Cleveland, Ohio 44139 • 440-248-0400 • Fax: 440-248-6168
 1-888-KEITHLEY (534-8453) • www.keithley.com

© Copyright 2005 Keithley Instruments, Inc.
 Printed in the U.S.A.

No. 2651
 0905