

Understanding

Jitter Measurement for Serial Digital Video Signals

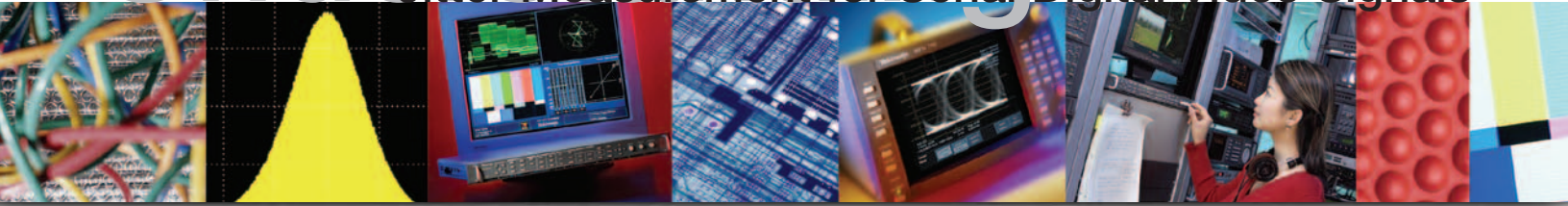

A Tektronix Video Primer

Contents

1.0 Introduction	3
2.0 Fundamental Concepts and Terminology	4
2.1. Encoding method, unit interval, SDI signals	4
2.2. Decoding process, clock recovery, bit scrambling	5
2.3. Time interval error, jitter, jitter waveform, jitter spectrum	5
2.4. Decoding errors, normalized jitter amplitude	6
2.5. Wander, timing jitter, alignment jitter	6
2.6. Random jitter, deterministic jitter	7
2.7. Intersymbol interference, equalization	8
2.8. Pathological signals, SDI checkfield	9
2.9. Decoding decision threshold, AC-coupling effects, symmetric signals	10
2.10. Jitter input tolerance, jitter transfer, intrinsic jitter, output jitter	11
2.11. Eye diagram, equalized Eye diagram	12
2.12. Equivalent-time Eye, Real-time Eye	14
2.13. Bit error ratio, Bathtub curve	15
3.0 Specifications on Video Jitter Performance and Measurement	17
3.1. Standards documents	17
3.2. Specifications on jitter frequency bandpass	18
3.3. Specifications on signal voltage levels and transition times	19
3.4. Specifications on connecting cables and other system elements	19
3.5. Specifications on peak-to-peak jitter amplitude	20
3.6. Specifications on measurement time	20
3.7. Specifications on data patterns	21
3.8. Summary of jitter specifications	21
4.0 The Functions Comprising Jitter Measurement	22
4.1. Equalization	22
4.2. Transition detection	23
4.3. Phase detection/demodulation	25
4.3.1. Phase detection/demodulation: Equivalent-time Eye method	25
4.3.2. Phase detection/demodulation: Phase Demodulation method	28
4.3.3. Phase detection/demodulation: Real-time Acquisition method	30
4.3.4. Phase detection/demodulation: Summary of methods	32
4.4. Measurement filters	33
4.4.1. Filter realization	33
4.4.2. Filter accuracy	35
4.5. Peak-to-Peak measurement	36
4.5.1. Peak-to-peak detection methods	36
4.5.2. Independent jitter samples and normalized measurement time	36
4.5.3. Measuring the peak-to-peak amplitude of random jitter	37
4.5.4. Measurement times	39
4.5.5. Dynamic range and jitter value quantization	39
4.6. Jitter noise floor	40
4.7. Comparing jitter measurement methods	41
5.0 Data Error Rates and Jitter Measurements	44
5.1. Random jitter and BER	44
5.2. Jitter measurement and standards compliance	45
5.3. BER and jitter measurement time	46
5.4. Jitter budget	47
6.0 Jitter Measurement with Tektronix Instruments	48
6.1. Jitter measurement with the Tektronix WFM700M	48
6.2. Jitter measurement with other Tektronix video instruments	48
6.2.1. Wander rejection	49
6.2.2. Measurement of random jitter	49
6.2.3. Measurement of deterministic jitter	50
6.3. Jitter measurement with Tektronix real-time oscilloscopes	50
7.0 Recommendations for Measuring Jitter in SDI Signals	51
7.1. Video system monitoring, maintenance and troubleshooting	51
7.2. Video equipment qualification and installation	51
7.3. Video equipment design	52
8.0 Conclusion	53
9.0 References	54
10.0 Acknowledgement	54
Appendix A: Impact of bandwidth limitation in video jitter measurement	55
Appendix B: Peak-to-Peak and RMS measurement of typical video jitter	57
Appendix C: Limits to clock recovery bandwidth	58

1.0 Introduction

In this technical guide, we describe the different techniques for measuring jitter in serial digital video signals and how they can lead to different measurement results. We further identify areas where the standards should supply additional specifications and guidance to help ensure more consistent jitter measurements.

This guide focuses on video jitter measurement techniques typically found in video-specific instruments, e.g., waveform monitors and video measurement sets. General-purpose measurement instruments, e.g., sampling and real-time oscilloscopes, are also used to measure jitter in serial digital video signals. These instruments can offer more extensive jitter analysis capabilities based on sophisticated signal processing.

We will briefly touch on some very basic aspects of video jitter measurement using general-purpose instruments in this guide, specifically related to comparing results with measurements made on video-specific instruments. We will not explore the range of jitter measurement capabilities available on sampling or real-time oscilloscopes, or on other general-purpose instruments.

For the most part, this guide describes jitter measurement methods broadly. It does not give details on specific implementations in particular instruments. It does describe some aspects of jitter measurement on Tektronix video-specific instruments to illustrate some of the key concepts discussed in the guide.

Timing variation in serial digital signals and the measurement of these timing variations are complex technical topics. To explain how and why jitter measurements differ, this guide gives a technical overview of jitter measurement techniques and includes technical descriptions of several key concepts. Although we examine jitter measurement in some detail, we do not comprehensively cover all aspects of this topic nor do we explore jitter measurement in extensive technical depth.

Rather, this guide focuses on describing common reasons for differences in measuring jitter in serial digital video signals. In particular, it examines differences associated with the jitter frequencies in the video signal and with the duration of the peak-to-peak amplitude measurements

used to characterize jitter in video systems. It will not cover some topics often mentioned in other discussions of jitter measurement, e.g., techniques for separating random and deterministic jitter components.

The material assumes some understanding of serial digital transmission theory and practice, the design and implementation of signal acquisition systems, the mathematical techniques used in characterizing signal transmission, and the properties of random processes.

This guide contains the following major sections:

- **Fundamental Concepts and Terminology:** Reviews the key concepts and terminology we will use to describe jitter measurement.
- **Specifications on Video Jitter Performance and Measurement:** Surveys relevant standards and specifications.
- **The Functions Comprising Jitter Measurement:** Examines the steps involved in measuring peak-to-peak jitter amplitude, the different ways to implement these steps, and the impacts these differences have on measurement results.
- **Data Error Rates and Jitter Measurements:** Explores the relationship between data error rates in video systems and the requirements for measuring the jitter performance of video equipment used in these systems.
- **Jitter Measurement with Tektronix Instruments:** Describes implementations of jitter measurement methods in Tektronix instruments and explains differences in measurement results.
- **Recommendations for Measuring Jitter in SDI signals:** Recommends tactics for effectively using jitter measurement methods and tools.

Jitter Measurement for Serial Digital Video Signals

► Primer

2.0 Fundamental Concepts and Terminology

In this section we review some fundamental concepts and terminology needed to describe jitter measurement. This review will briefly touch on several concepts. It does not cover these concepts in any depth.

Those experienced in digital communications will be familiar with many of the concepts reviewed in this section. They may wish to skip this part of the guide, or scan the material to review any less familiar terminology or concepts.

2.1 Encoding method, unit interval, SDI signals

Distributing digital video over any significant distance requires converting the digital content into a serial digital video signal. Creating these signals involves converting the original digital content into a sequence of individual bits and representing these bits by voltage or light waveforms. A clock signal determines the time interval used to encode a bit in the sequence and an *encoding* method determines the signal characteristics that represent a '0' or a '1' bit value, e.g., Manchester encoding or NRZ encoding. The time interval corresponding to one bit in these serial data signals is called the *unit interval* (UI).

The Society of Motion Picture and Television Engineers (SMPTE) has approved standards that define a *serial digital interface* (SDI) for digital video equipment. SMPTE 259M defines the interface for standard-definition (SD) digital video formats and SMPTE 292M deals with high-definition (HD) video formats. We will refer to serial digital video signals conforming to these standards as *SDI signals*.

The SMPTE standards define serial digital interfaces for several different video formats. The information on jitter measurement given in this technical guide applies to SDI signals conforming to any of these specifications. In this guide, we will reference two very common types of SDI signals:

- The 270 Mb/s signals conforming to SMPTE 259M specifications for standard-definition, 4:2:2 component video with either a 4x3 or 16x9 aspect ratio as defined in ITU-R BT.601- 5 (SD-SDI signals)
- The 1.485 Gb/s signals conforming to SMPTE 292M specifications for various high-definition video formats (HD-SDI signals)

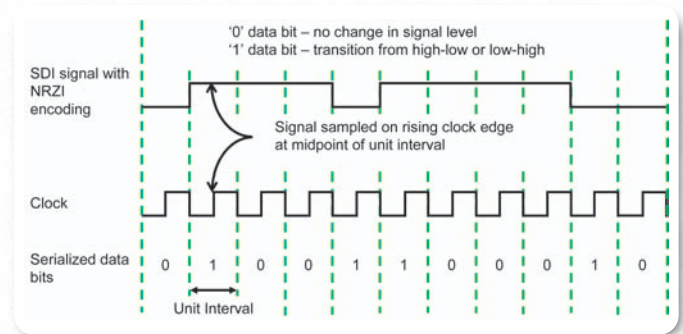

► **Figure 1.** Unit interval and encoding method for SDI signals.

The SMPTE standards specify that the clock frequency used to create these SDI signals will equal the signal bit rate. As a result, SDI signals encode one bit in one clock cycle, i.e. the unit interval equals the clock period. So, the unit interval of a 270 Mb/s SD-SDI signal equals one period of a 270 MHz clock or 3.7 ns. Similarly, the unit interval of a 1.485 Gb/s HD-SDI signal equals 673 ps or one period of a 1.485 GHz clock.¹

The SMPTE standards also specify that SDI signals encode the serialized data-bit values using the NRZI method (Non-return to Zero Inverted). In this method, '0' bit values are encoded as no change in the signal level, while '1' bit values are encoded as a change in the current signal level. If the current signal is high, a '1' bit value causes a transition to the low signal level. If the current signal level is low, a '1' bit value causes a transition to the high signal level (Figure 1).

¹ SMPTE 292M also defines an HD format with a data rate of 1.485 GHz/1.001. This SDI signal has a unit interval of 674 ps.

2.2 Decoding process, clock recovery, bit scrambling

To extract the digital content from an SDI signal, video equipment samples the SDI signal at the midpoint of the time intervals containing data bits (see Figure 1) and converts these sampled levels to the corresponding bit values. The sampling process uses a clock with the same frequency as the encoding clock, and aligned in time to ensure sampling occurs at the midpoint of the unit interval.

Typically, video equipment does not have direct access to the clock used to create the serial data signal. Instead, equipment implements a *clock recovery* process that uses a phase-lock loop (PLL) to extract the appropriate sampling clock from the received signal. For reliable clock recovery, the *edges* in the SDI signal, i.e. transitions between the signal levels, must occur at an adequate rate. Long periods of a constant signal level can cause the sampling clock to drift out of synchronization.

Because of the NRZI encoding, long sequences of '1' bit values in the serialized data sequence will have edges at each bit in the sequence. However, serialized digital video content can easily contain extended sequences of '0' bit values. This could create SDI signals with long periods at a constant signal level. To avoid this, the SMPTE standards specify that SDI signal sources will randomize the data before applying the NRZI encoding, using a process known as *scrambling*.

The scrambling process in an SDI signal source converts the serialized data bits into a pseudo-random bit sequence. SDI receivers implement the inverse of this scrambling process to extract the original data bit sequence from the pseudo-random bit sequence. In most cases, this scrambling process ensures a fairly large number of bit transitions, although long sequences of '0' bits can infrequently occur.

2.3. Time interval error, jitter, jitter waveform, jitter spectrum

Ideally, the time interval between transitions in an SDI signal should equal an integer multiple of the unit interval. In real systems, however, the transitions in an SDI signal can vary from their ideal locations in time. This variation is called *time interval error* (TIE), commonly referred to as *jitter*. This timing variation can be induced by a variety of frequency, amplitude, and phase-related effects. In this guide, we will view jitter as essentially a phase variation in a signal's transitions, i.e. a phase modulation of the serial data signal.

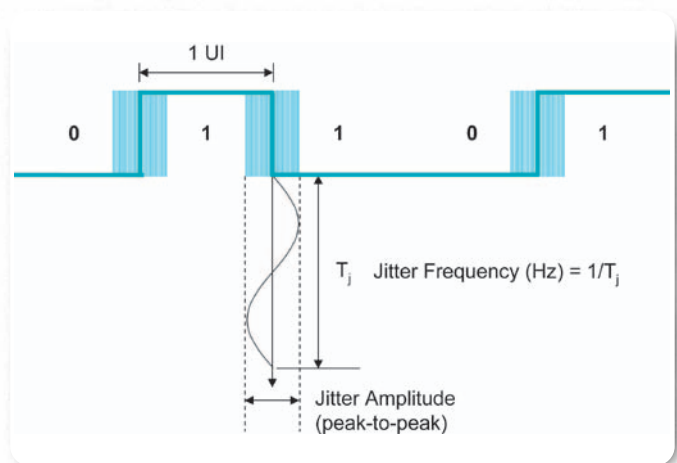

▶ **Figure 2.** SDI signal with sinusoidal edge variation (ideal positions shown in darker lines).

As a simple example, suppose the edges in an SDI signal have a sinusoidal variation around their ideal positions relative to a reference clock. If we viewed this SDI signal on an oscilloscope triggered on the reference clock, the actual edges would appear as a blur around the ideal positions as illustrated in Figure 2. We can fully define this simple sinusoidal jitter with two parameters, the frequency of the variation and its peak-to-peak amplitude.

In actual SDI signals, jitter will rarely have the simple sine wave characteristics shown in this example. In real systems, a wide variety of factors influence the timing of signal transitions. These different sources introduce variations over a range of frequencies and amplitudes. The peak amounts that any particular edge leads or lags its ideal position may differ and there may be long time intervals between edges with large peak-to-peak variation.

The *jitter waveform* is the amount of variation in a signal's transitions as a function of time, and the *jitter spectrum* is the frequency-domain representation of the time-domain jitter waveform. In actual signals, the jitter waveform typically has a complex shape created by the combined effects of various sources, and the jitter spectrum contains a wide range of spectral components at different frequencies and amplitudes.

Jitter Measurement for Serial Digital Video Signals

► Primer

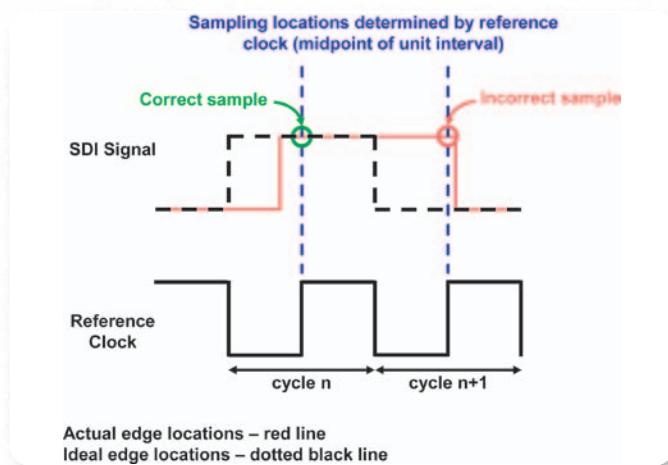

► **Figure 3.** Decoding error caused by a large amplitude variation in edge position.

2.4. Decoding errors, normalized jitter amplitude

In the decoding process, SDI receivers use a reference clock to determine when to sample the input SDI signal. Ideally, the transitions in the input SDI signal occur at appropriate clock edges and sampling occurs at the midpoint of the unit interval. In the ideal situation shown in Figure 1, the signal transitions align with the clock's falling edges and sampling occurs at the clock's rising edges.

Real SDI signals, however, have some amount of jitter in their edges. Jitter of sufficiently large amplitude will cause sampling errors. Figure 3 illustrates this situation. It shows an SDI signal that encodes two '1' bit values during two clock periods, n and $n+1$. In the ideal situation, the sampling process would capture a high signal value in clock period n and a low signal value in clock period $n+1$.

In the actual signal, the transitions vary significantly from their ideal locations relative to the reference clock. During clock period n , the actual edge varies by less than one-half the reference clock period. At the sampling time determined by the reference clock, the sampling process captures a high signal value, as it would in the ideal situation.

During clock period $n+1$, however, the actual transition occurs more than one-half the clock period from its ideal position relative to the reference clock. Since the actual edge occurs after the sampling time determined by the reference clock, the sampling process captures a high signal value instead of the low signal value it would have sampled in the ideal situation.

When expressed in seconds, the amount of timing variation needed to generate a decoding error depends on the clock period, i.e. the size of the unit interval. For a 1.485 Gb/s

HD-SDI signal a variation of 340 ps is more than one-half the 673 ps unit interval, while for a 270 Mb/s SD-SDI signal this same variation is less than one-tenth of this signal's 3.7 ns unit interval.

In order to describe these timing variations without referring to specific signal data rates, amplitudes are typically expressed using unit intervals. In these normalized units, the variation shown in Figure 3 for clock period $n+1$ has an amplitude value of slightly more than 0.5 UI. An amplitude value of 0.5 UI would equal 1.85 ns in an SD-SDI signal and 337 ps in an HD-SDI signal.

2.5. Wander, timing jitter, alignment jitter

In the preceding examples, we have described variations in the position of signal transitions with respect to an ideal, jitter-free reference clock, i.e. a clock signal in which all edges occur at their ideal locations in time. Actual reference clocks used in decoding are not jitter free.

As noted in section 2.2, the decoding process typically uses a recovered clock extracted from the received SDI signal. The clock recovery process "locks" the recovered clock to the input signal and the clock will follow timing variations in the input signal that fall within the bandwidth of the recovery process. Hence, the timing variations in the SDI signal introduce variations in the transitions of the recovered clock.

Since the transitions in the recovered clock determine when the decoder samples the SDI signal, using a recovered clock actually reduces the number of decoding errors associated with low frequency variations. The sampling time "tracks" these variations and samples at the correct location inside the unit interval.

The recovered clock does not track variations in signal transitions if the frequency of the variation lies above the bandwidth of the clock extraction process. At these higher frequencies, the position of signal transitions can vary relative to the edges of the recovered clock and these variations can create decoding errors.

As noted in section 2.3, the jitter spectrum in actual SDI signals generally contains a range of spectral components. The recovered clock will generally track spectral components below the clock recovery bandwidth, but will not track spectral components above this bandwidth. Hence, the impact of jitter on decoding depends on both the jitter's amplitude and its frequency components. This has led to a frequency-based classification of jitter.

Conventionally, the term “jitter” refers to short-term time interval error, i.e. spectral components above some low frequency threshold. For SDI signals, the SMPTE standards set this threshold at 10 Hz and refer to spectral components above this frequency as *timing jitter*.

The term *wander* refers to long-term time interval error. For SDI signals, components in the jitter spectrum below 10 Hz are classified as wander. Since video equipment can generally track these long-term variations, characterizing wander in terms of actual edge positions relative to their ideal positions does not give meaningful information. Instead, wander is measured in terms of frequency offset and frequency drift rate. These parameters characterize the deviation from expected clock rates in normalized units of parts per million (ppm and ppm/sec) or parts per billion (ppb and ppb/s) rather than UI.

Alignment jitter refers to components in the jitter spectrum above a specified frequency threshold related to typical bandwidths of the clock recovery processes. In other words, alignment jitter is a subset of timing jitter that excludes spectral components the clock recovery process can track. The specified frequency threshold differs for SD-SDI and HD-SDI signals and is defined in the relevant SMPTE standard (see section 3.2). For SD-SDI signals, alignment jitter refers to spectral components above 1 kHz. For HD-SDI signals, spectral components above 100 kHz are classified as alignment jitter.

In general, video equipment does not track alignment jitter, though some equipment may track some low frequency alignment jitter. Thus, high amplitude alignment jitter generally introduces decoding errors. Since video equipment can track wander and low frequency timing jitter, these spectral components often have less impact on signal decoding.

While low frequency variations may have less impact on signal decoding, they can have significant impact in other areas. Other processes, e.g., digital-to-analog conversion stages, use this recovered clock, or a sub-multiple of this clock. Since this clock tracks the low frequency jitter in the input SDI signal, its edges vary from their ideal positions. This jitter in the clock signal can introduce errors, e.g., non-linearity in D-to-A conversion.

Clock recovery also affects the way jitter and wander accumulate in a video system. Reclocking video equipment uses the recovered clock to regenerate the SDI signal. Since the recovered clock does not track alignment jitter well, reclocking can substantially reduce alignment jitter.

However, reclocking may not significantly reduce wander or low-frequency timing jitter since the recovered clock tracks these variations. Hence, low-frequency variations can build through a video system. Amplitudes can eventually grow beyond the tracking capability of clock recovery processes. At this point, decoding errors will appear and the clock recovery hardware might not remain locked to the input signal.

This guide examines techniques for measuring timing and alignment jitter. We will not examine wander and wander measurement techniques. However, wander does impact jitter measurements since these measurements must exclude contributions from spectral components below 10 Hz. Differences in wander rejection can lead to different measurement results, and we will examine these effects in later sections.

2.6. Random jitter, deterministic jitter

To fully understand the impact of jitter in video systems, we need to consider its statistical properties in addition to its amplitude and spectral content. Commonly used approaches to characterizing and modeling these properties distinguish between two basic jitter types. *Random jitter* has essentially no discernable pattern. It is best characterized by a probability distribution and statistical properties like mean and variance. *Deterministic jitter* is more predictable (determinable) and is often characterized by some definable periodic or repeatable pattern with a determinable peak-to-peak extent.

Random jitter

Random processes, e.g., thermal or shot noise, introduce random jitter into an SDI signal. We typically use a Gaussian probability distribution to model this jitter behavior, and we can use the standard deviation of this distribution (equivalent to the RMS value) as a measure of the jitter amplitude. However, the peak-to-peak jitter amplitude and the RMS jitter amplitude are not the same. In particular, the peak-to-peak amplitude value depends on the observation time.

In the Gaussian distribution used to model random jitter, small amplitude variations in edge position are most probable, but very large amplitude variations may infrequently occur. A record of amplitudes made over a short observation time could include a large amplitude value, but probably will not. By contrast, a record of amplitudes made over a long observation time might not contain any large amplitude values, but probably will contain at least one. So, on average, we would expect that a peak-to-peak ampli-

Jitter Measurement for Serial Digital Video Signals

► Primer

tude measurement made over a long observation time would have a larger value than a peak-to-peak amplitude measurement made over a short observation time.

The “tails” of a Gaussian distribution can reach arbitrarily large amplitudes. Hence, by observing over a sufficiently large time interval, we could theoretically measure arbitrarily large peak-to-peak jitter amplitude. We describe this property by saying that random jitter has “unbounded” peak-to-peak amplitude.

Technically, this description applies only to the mathematical model for random jitter. For all practical purposes, however, a Gaussian distribution adequately models random jitter in real systems. Thus, we can say that over any region of interest, random jitter in actual SDI signals has unbounded peak-to-peak amplitude.

Deterministic jitter

A wide range of sources can introduce deterministic jitter into an SDI signal. For example:

- Noise in a switching power supply can introduce *periodic* deterministic jitter.
- The frequency response of cables or devices can introduce *data-dependent jitter* that is correlated to the bit sequence in the SDI signal (see section 2.7).
- Differences in the rise and fall times of transition can introduce *duty-cycle dependent jitter* (see section 4.2).

In addition to these general sources of deterministic jitter, SDI signals can contain deterministic jitter correlated with video properties. For example:

- The line and field structure of video data can introduce a periodic deterministic jitter that we will call *raster-dependent jitter*.
- Converting the 10-bit words used in digital video to and from a serial bit sequence can introduce high frequency data-dependent jitter at 1/10 the clock rate, typically called *word-correlated jitter*.

Deterministic jitter attains some maximum peak-to-peak amplitude within a determinable time interval. Increasing the observation time beyond this time interval will not increase the peak-to-peak jitter amplitude measurement. Unlike random jitter, repeatable deterministic jitter has a determinable upper bound on its peak-to-peak jitter amplitude.

Even if deterministic jitter has infrequent long-term determinable behavior, this jitter can be adequately modeled with a predictable pattern that has bounded peak-to-peak

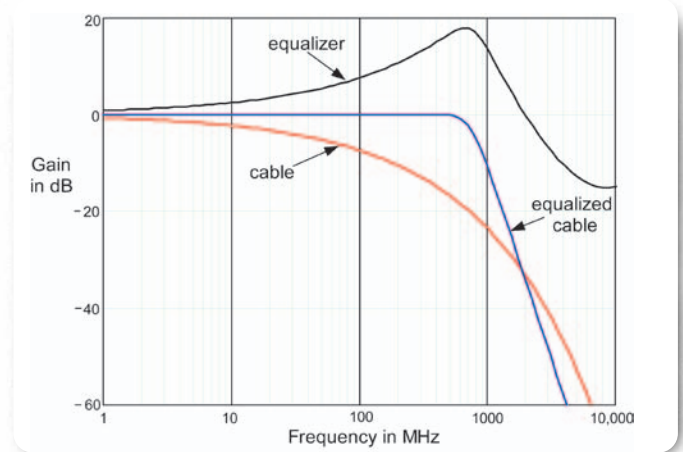

► **Figure 4.** Frequency response for 300 m of cable and typical response of a compensating equalizer.

amplitude. Thus, for all practical purposes, deterministic jitter has bounded peak-to-peak amplitude and random jitter has unbounded peak-to-peak jitter amplitude.

2.7. Intersymbol interference, equalization

In real serial digital signals, transitions from one voltage level to another do not occur instantaneously. They have finite rise and fall times. Further, the frequency-dependent response of devices and communication channels will cause temporal spreading in these transitions. *Intersymbol interference* (ISI) occurs when the spreading of transitions in earlier bits affect transitions in later bits.

These effects cause transitions to vary from their ideal shapes and locations. In other words, ISI introduces jitter in the signal. Specifically, it produces predictable and repeatable jitter whose magnitude depends on the frequency responses of devices and channels, and on the data patterns in the signal. Hence, ISI produces deterministic, data-dependent jitter.

In particular, cable attenuation greater than 1 dB can introduce significant intersymbol interference. To avoid data errors due to this ISI, receivers typically have cable equalizers that compensate for the $1/\sqrt{f}$ frequency response of the cable. Figure 4 shows the typical frequency responses of a cable and equalizer.

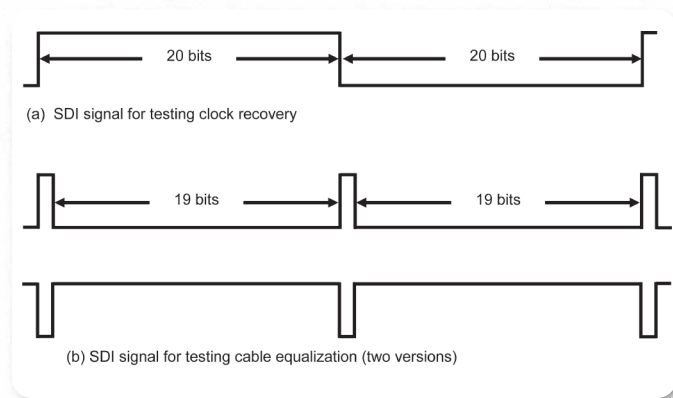

▶ **Figure 5.** SDI signals for stress testing clock recovery and cable equalization.

2.8. Pathological signals, SDI checkfield

As noted in section 2.2, clock recovery requires frequent signal transitions, i.e. the signal must have a sufficient *transition density*. Cable equalization algorithms also need many edges in the signal to determine and maintain the frequency-dependent gain that compensates for the $1/\sqrt{f}$ frequency response of the cable. Long intervals of constant signal level stress these processes and can lead to decoding errors or synchronization problems. Further, AC-coupling can reduce noise margins in decoding if the input signal remains at the same voltage level for a significant percentage of time (see section 2.9).

In most cases, scrambling and NZRI encoding ensures that SDI signals have many transitions. Typical SDI signals do not have long intervals of constant voltage that stress clock recovery, equalization, or decoding processes.

However, particular word patterns in digital video content can produce SDI signals with long constant-voltage intervals. If the shift register used in the scrambling process has a particular state and the scrambler receives one of several special input bit sequences, the resulting SDI signal after NRZI encoding will have one of the patterns shown in Figure 5. The paper by Takeo Eguchi listed in the References provides additional information.

SDI signals containing these patterns are called *pathological* SDI signals. Video semiconductor and equipment designers can use these signals to “stress test” clock recovery and equalization processes and to verify the correct operation of clamping or DC-restoration circuits that compensate for AC-coupling effects. As shown, the patterns needed for testing equalization differs from the pattern needed to stress test the clock recovery PLL.

Once initiated, the stress patterns in pathological SDI signals occur only to the end of an active video line. SDI signal formats insert information between lines of active video content, e.g., the SAV (start-of-active-video) and EAV (end-of-active-video) synchronization words. This added information disrupts the special shift register state and bit sequences that create these long constant-voltage intervals. Even if the next active line contains the same special bit sequence, the shift register will generally not have the appropriate initial state and the SDI signal will not contain the stress patterns.

Repeating the special bit sequence on multiple video lines will cause the stress pattern to reappear. Eventually, the shift register in the scrambler will enter an appropriate initial state at the right position in the bit sequence. When this occurs, the stress pattern will reappear and will continue to the end of the active video line. The conditions needed to initiate a stress pattern happen infrequently. So, pathological SDI signals consist of occasional occurrences of video lines containing stress patterns statistically interspersed among many video lines that look like typical SDI signals.

Some video test signal generators can create these signals in either full-field formats, or in split-field formats that combine the clock recovery and equalizer stress patterns. For testing recovery and equalization in video equipment with SDI inputs, SMPTE developed two recommended practices (RP 178 and RP 198) that define a specific split-field format called an *SDI checkfield*.

Jitter Measurement for Serial Digital Video Signals

► Primer

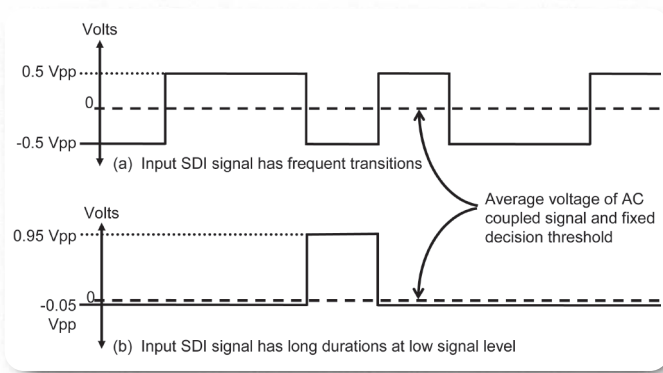

► **Figure 6.** Shift in AC-coupled signals relative to fixed decision level.

2.9. Decoding decision threshold, AC-coupling effects, symmetric signals

To determine whether a sampled signal voltage corresponds to a “high” or “low” signal level, decoders compare the sampled voltage against a particular voltage level called the *decision threshold* or *decision level*. An optimally chosen decision threshold will equally protect against errors generated by noise on either signal level. If each signal level has the same amount of noise, the optimal decision threshold equals the average of the two signal voltage levels.

SDI receivers generally use fixed decision thresholds in the decoding process. For optimal performance, signal levels must keep the same relative relationship to this fixed voltage level. A shift in the signal relative to the decision threshold reduces the noise margin for one of the signal levels, which can lead to decoding errors.

SDI receivers typically have AC-coupled inputs that remove DC-offsets in the input SDI signal and maintain a constant average voltage in the AC-coupled signal. In many implementations, this average signal level equals zero volts, although biasing circuitry in the receiver could set the average signal level of the AC-coupled signal to a non-zero value. Typically, the fixed decision threshold equals the average voltage of the AC-coupled signal. However, the optimal decision threshold may differ from the average signal voltage if one signal level can have more noise than the other.

While AC-coupling filters out DC offsets in the input SDI signal that could lead to decoding errors, it can also shift the signal levels in the AC-coupled signal relative to a fixed decision threshold. Figure 6 illustrates this situation for an implementation of AC-coupling that maintains the average signal level in the AC-coupled signal at zero volts. In this example, the decoding process also uses zero volts as the fixed decision threshold.

Figure 6a shows a segment of an AC-coupled signal derived from an input SDI signal that does not contain any long duration at the same voltage level. In this case, the high signal level in the AC-coupled signal equals $+0.5 \cdot V_{pp}$ and the low signal level equals $-0.5 \cdot V_{pp}$, where V_{pp} is the peak-to-peak amplitude of the input SDI signal. The fixed decision threshold falls at an optimal position midway between the two levels.

Figure 6b shows a segment of an AC-coupled signal derived from an input SDI signal that stays at the low signal level for long periods of time, e.g., one of the equalizer stress patterns described in section 2.8. In this example, the signal remains at the low signal level 95% of the time. To maintain an average signal level of zero volts, the low signal level in the AC-coupled signal must equal $-0.05 \cdot V_{pp}$, while the high signal level must equal $+0.95 \cdot V_{pp}$. The low signal level is very close to the fixed decision threshold for decoding, which eliminates the noise margins for this signal level and will lead to decoding errors.

In effect, the AC-coupling has generated intersymbol interference. The values of earlier bits (long strings of ‘0’ bit values after scrambling) have impacted the decoding of later bits.

The amount of shift depends on the coupling time constant. For example, with a coupling constant of 10 μsec , an equalizer stress pattern will shift almost 78% closer to the fixed decision level over one-half of an HD video line. With a coupling time constant of 75 μsec , the stress pattern will shift by less than 33% over an entire HD video line.

To compensate for this AC-coupling effect, SDI receivers typically clamp or DC-restore the AC-coupled signal to maintain the relationship between the signal levels and the fixed decision threshold.

Due to scrambling and NRZI encoding, SDI signals are *symmetric*, i.e. they spend nearly the same amount of time at each signal level. More specifically, typical SDI signals are symmetric when signal levels are averaged over many unit intervals. Shorter-term, SDI signals can have several periods of constant signal level, with pathological SDI signals as the extreme case.

Even in SDI signals with frequent transitions, AC-coupling can introduce a shift in the signal relative to the fixed decision level. If the rise and fall times of signal transitions differ significantly, the signal will spend more time at one of the signal levels. For example, if the signal has fast rise times and slow fall times, it will spend more time in the high signal state. AC-coupling will then shift the high signal level closer to the fixed decision threshold, reducing noise margin.

Typically, SDI signals have symmetric rise and fall times, but asymmetric line drivers and optical signal sources (lasers) can introduce non-symmetric transitions. While significant, these source asymmetries do not have especially large impacts on signal rise and fall times. In particular, cable attenuation will generally have a much larger impact on signal transition times.

Without appropriate compensation or other adjustments, asymmetries in SDI signals can reduce noise margins with respect to the decision threshold used in decoding and can lead to decoding errors. As we explore in section 4.2, these same asymmetric conditions can also impact jitter measurements.

2.10. Jitter input tolerance, jitter transfer, intrinsic jitter, output jitter

SDI signal receivers can differ in their implementations of the processes described in the preceding sections. A particular receiver's clock recovery process may not track jitter as well as others, or it may not sample the SDI signal near the midpoint of the unit interval. The design and hardware a receiver uses to implement equalization, clock recovery and decoding processes may introduce a significant amount of additional jitter into the signal. Thus, a particular receiver may have multiple data errors when decoding SDI signals that other receivers can decode without error. Such a receiver has a lower *jitter input tolerance*.

A receiver's jitter input tolerance depends on the jitter frequencies in the SDI signal. As noted in section 2.5, clock recovery can track low frequency jitter, so receivers typically have a higher tolerance for low frequency jitter. The jitter input tolerance drops significantly for jitter frequencies above the clock recovery bandwidth.

Some video equipment, e.g., a distribution amplifier, produces an SDI output from an SDI signal applied at an input. Typically, jitter in the input SDI signal does not directly translate to jitter in the corresponding output. In particular, clock recovery can filter out high frequency jitter, or may amplify some jitter in the input signal. *Jitter transfer* is the jitter on an SDI output resulting from jitter in an input SDI signal, and the *jitter transfer function* is the ratio of output jitter to applied input jitter as a function of frequency.

Like receivers, source and regeneration equipment also has internal jitter. This internal jitter will appear on an SDI output signal even if the associated SDI input has no jitter. *Intrinsic jitter* is the amount of jitter at an SDI output in the absence of input jitter. *Output jitter* is the total amount of jitter at an SDI output resulting from intrinsic jitter and the transfer of jitter in any associated SDI input.

Jitter Measurement for Serial Digital Video Signals

► Primer

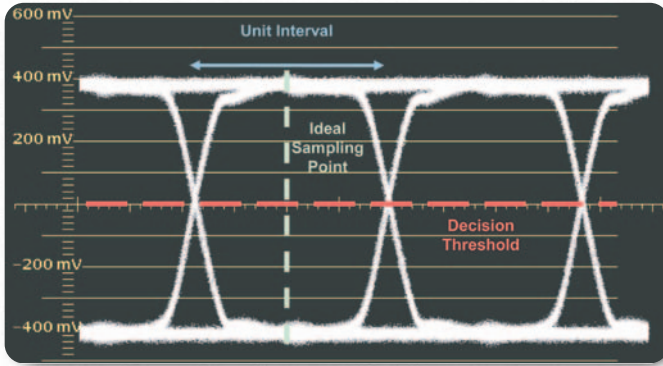

► **Figure 7.** Eye diagram for signal with very small amplitude jitter.

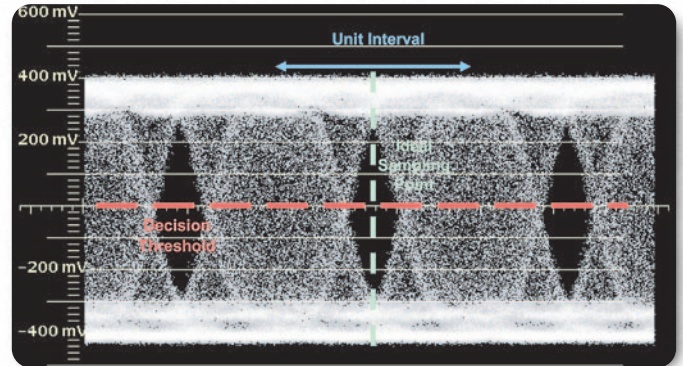

► **Figure 8.** Nearly closed Eye caused by large amplitude jitter.

2.11. Eye diagram, equalized Eye diagram

Engineers commonly use Eye diagrams to analyze serial data signals and diagnose problems. Measurement instruments create Eye diagrams by superimposing short segments of the serial data signal. The finite rise and fall times of these transitions create the characteristic ‘X’ patterns in the Eye diagram (see Figure 7). The eye-shaped area without transitions gives the display its name. We will call the point where the rising and falling edge transitions intersect the *crossover points* in the Eye diagram.

The time interval between the crossover points in the Eye equals the unit interval. In the ideal case, the decoding process samples the signal at the mid-point between the crossover points and the decision threshold corresponds to the widest part of the Eye opening (Figure 7).

To make the Eye diagram, the instrument aligns the segments using a reference clock signal. Typically this reference clock is extracted from the data signal, but may be a separate reference clock signal. It can be externally supplied, e.g., through the trigger input on an oscilloscope, or extracted within the measurement instrument.

If the transitions in the input signal align with the edges in this reference clock they will lie on top of each other in the Eye diagram. Any transitions that vary from the nominal positions determined by this reference clock will appear in different locations. If the instrument uses a recovered clock to form the Eye diagram, the reference clock will track jitter below the loop bandwidth of this clock recovery process. Thus, the Eye diagram will only show jitter components with frequencies above this bandwidth threshold, called the *Eye clock recovery bandwidth*.

For signals with a small amount of jitter, the edges in the aligned segments occur in nearly the same location. The small variations in edge position create only a slight “blur” around the nominal edge positions (see Figure 7). Most of the space between the crossover points is free of transitions. In this situation, we say the Eye is “open.”

As the amplitude of the jitter increases, more transitions move into the open space between crossover points, i.e. the Eye starts to “close” (see Figure 8).

Using Eye diagrams, engineers can quickly form a qualitative impression of the jitter in a signal and the potential for decoding errors. Overall, a signal that forms a large, wide-open Eye is less likely to produce decoding errors than a signal that forms a small or closed Eye. However, in making this qualitative assessment, one of the key factors engineers need to consider is the difference between the Eye clock recovery bandwidth and the bandwidth of the receiver’s clock recovery process.

If the clock recovery bandwidth in the receiver equals the Eye clock recovery bandwidth, the size of the Eye opening correlates reasonably well with the potential for decoding errors. If the input signal forms a large, “wide-open” Eye, the decoding process will most likely sample the signal before the transition to the next bit.

If the clock recovery bandwidth in the receiver is less than the Eye clock recovery bandwidth, the signal may contain jitter frequencies below the Eye clock recovery bandwidth that impact the decoding process but do not appear in the Eye diagram. The decoding process may generate errors even though the Eye diagram has a large Eye opening.

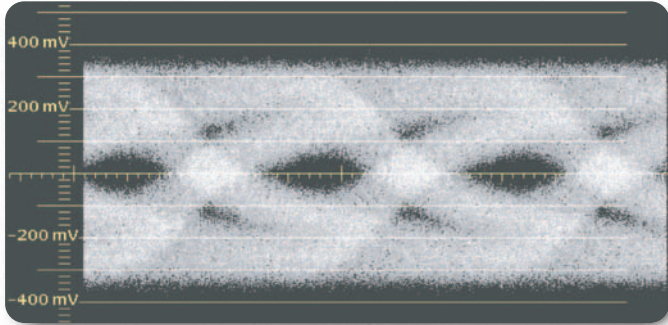

► **Figure 9.** Eye diagram for SD-SDI signal showing a nearly closed Eye due to attenuation in a 100 m cable.

On the other hand, if the clock recovery bandwidth in the receiver is greater than the Eye clock recovery bandwidth, the Eye diagram may show jitter that does not impact the decoding process. The receiver may decode the signal without errors even though the Eye diagram has a small Eye opening or is completely closed.

Other factors also influence the qualitative assessment of signal jitter using Eye diagrams. If receivers introduce a significant amount of internal jitter or do not consistently sample near the middle of the unit interval, they may generate more decoding errors than suggested by the size of the Eye opening.

Thus, in using an Eye diagram to assess the potential for data errors, engineers need to consider the combined effects of the receiver's clock recovery, equalization and decoding processes. In other words, they need to consider the receiver's jitter input tolerance (see section 2.10). A receiver with low jitter input tolerance can generate errors in decoding a signal that forms a wide-open Eye diagram, while a receiver with high jitter input tolerance may correctly decode a signal that forms a closed Eye diagram.

As noted in section 2.7, frequency-dependent cable attenuation "spreads" transitions in SDI signals. This intersymbol interference can significantly reduce or completely close the Eye opening in an Eye diagram constructed from a signal at the end of a long cable (see Figure 9).

However, a small or closed Eye opening in the Eye diagram of a non-equalized signal at the end of a long cable does not necessarily indicate a high potential for decoding errors. The cable equalization used in receivers will restore the signal's transitions and "re-open" the Eye. With adequate equalization, the ISI from cable attenuation will not significantly impact the decoding process. Without adequate equalization, the data-dependent jitter introduced by cable effects can lead to decoding errors.

While equalization can compensate for cable effects, the equalized signal can still contain signal jitter or amplitude noise that reduces or closes the Eye opening. To qualitatively assess the remaining potential for decoding errors after equalization, engineers can use an *equalized Eye diagram* constructed from the equalized version of the input signal.

Eye diagrams can also show AC-coupling effects. Signal level shifts due to AC-coupling (section 2.9) causes a corresponding shift in the superimposed segments that form the Eye diagram. This can occur even if the measurement instrument forming the Eye-diagram has a DC-coupled input. Other equipment in the system may have AC-coupled inputs, causing shifts in the SDI signal before it reaches the measurement instrument.

Jitter Measurement for Serial Digital Video Signals

► Primer

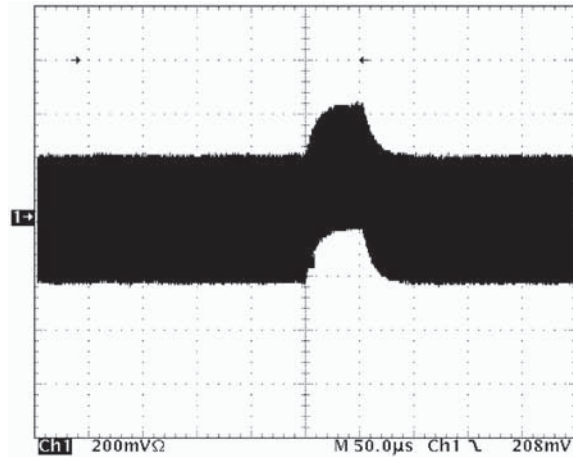

(a) Pathological SDI signal with equalizer stress pattern in an Eye display at a sweep rate of several video lines

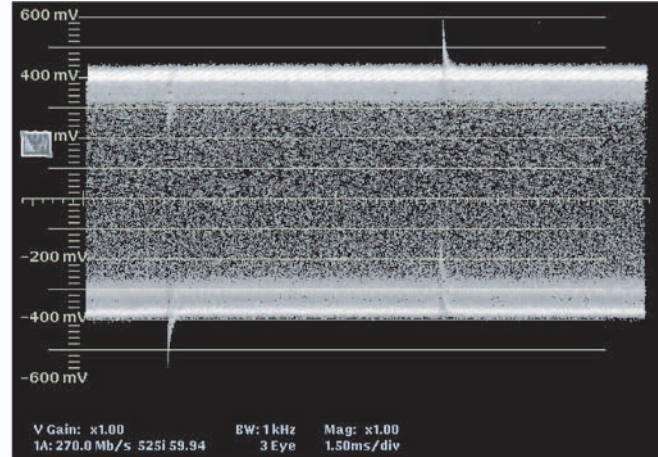

(b) Eye display for same pathological SDI signal at a video field sweep rate

► **Figure 10.** AC-coupling effects.

Figure 10a shows a pathological SDI signal containing an equalizer stress pattern in an Eye display set to a sweep rate equal to several video lines. At this slow sweep rate, the resulting waveform contains thousands of individual Eyes per division. This display clearly shows that the signal levels shift higher because of AC-coupling effects due to the long intervals at a low signal level (top pattern in Figure 5b).

Figure 10b shows an Eye display for the same signal using a much lower sweep rate that displays a full video field. This display demonstrates the effects from the two different equalizer stress patterns shown in Figure 5b.

2.12. Equivalent-time Eye, Real-time Eye

The instruments most commonly used to monitor and measure signal jitter construct Eye diagrams by sampling the input signal. They acquire these samples using two different methods.

Many instruments, including waveform monitors and other video-specific measurement instruments, use *equivalent-time sampling* techniques to create the Eye diagram. These techniques use under-sampling to approximate an over-sampled acquisition. We will refer to an Eye diagram constructed in this manner as an *Equivalent-time Eye*.

Measurement instruments use different equivalent-time sampling techniques with a wide range of capabilities and characteristics. Broadly speaking, because of the under-sampling used in this approach, the “edges” in the Eye

diagram represent the composite effect of many separated edges in the actual signal, possibly widely-separated edges. The sampling rate used to construct the Eye can strongly influence the results of peak-to-peak jitter amplitude measurements (section 4.3.1).

Real-time digital oscilloscopes can construct an Equivalent-time Eye diagram using the equivalent-time technique mentioned above. They can also construct Eye diagrams using real-time sampling techniques that over-sample the input signal. These instruments use software-based clock recovery techniques in creating the Eye.

We will refer to an Eye diagram constructed using this real-time sampling technique as a *Real-time Eye*. In this technique, the edges in the Eye diagram are actual edges in the input signal. The amount of acquisition storage and the sampling rate will influence the results of peak-to-peak jitter amplitude measurements (section 4.3.3).

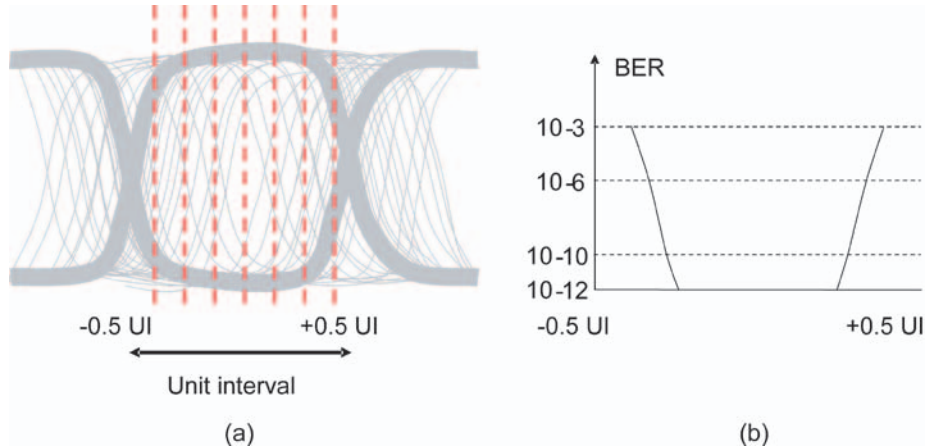

▶ **Figure 11.** Bathtub curve – BER vs. location in Eye Diagram.

2.13. Bit error ratio, Bathtub curve

All SDI signals contain some amount of random jitter. As noted in section 2.6, random jitter has no discernible pattern. Thus, decoding errors due to random jitter in a signal will not occur at determinable times or rates. In place of error rates, the combined impact of deterministic and random jitter on decoding can be usefully characterized by a *bit error ratio* (BER), the ratio of the number of incorrectly decoded bits to the total number of bits decoded.

For example, consider an HD-SDI signal with a small amount of random jitter and a receiver that always samples at the midpoint of the unit interval. Suppose that the total jitter in this signal, i.e. the combined effects of deterministic and random jitter, causes sampling errors in this receiver at an average rate of 1 per minute. In one minute, the 1.485 Gb/s HD-SDI signal transmits 8.91×10^{10} bits. So, the total jitter in the signal corresponds to a BER of at least 1.12×10^{-11} in this ideal receiver. For a 270 Mb/s SD-SDI signal, an average of one decoding error per minute corresponds to a BER of at least 6.17×10^{-11} . Due to error propagation effects in the SDI receiver associated with bit scrambling and NRZI to NRZ conversion, one sampling error can lead to multiple bit errors, producing a higher BER.

Now imagine moving the sampling location away from the midpoint of the unit interval and towards one of the crossover points in the Eye diagram. Figure 11a illustrates this process with a sketch of an Eye diagram that has accumulated edges long enough for large amplitude random jitter to nearly close the Eye. As the sampling location moves closer to a crossover point, smaller jitter amplitudes can now cause transitions to occur in the wrong position relative to the sample location.

In random jitter, smaller amplitude variations happen more frequently than larger amplitude variations. Thus, as the sampling location moves towards a crossover point, random jitter can more frequently shift transitions into the wrong positions relative to the sampling location. This leads to an increased number of decoding errors and an increased BER.

The sketch in Figure 11b shows this relationship between the BER due to jitter in a signal and the sampling location in the unit interval. This is called a *Bathtub plot* or a *Bathtub curve* because the shape looks like a cross-section of a bathtub.

Jitter Measurement for Serial Digital Video Signals

► Primer

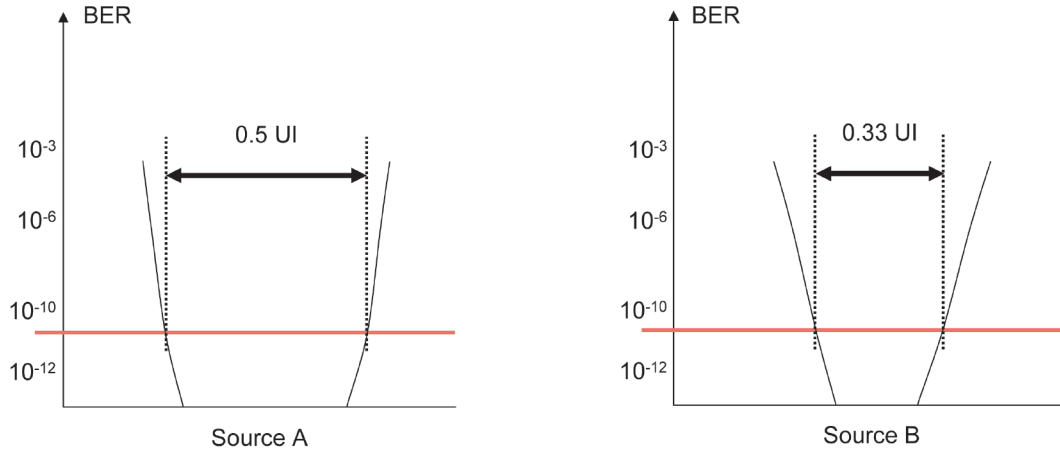

► **Figure 12.** Bathtub curves at the receiver input for SDI signals from two sources.

Bathtub curves are useful in assessing whether a video system can achieve a target BER. For example, suppose an operation wants the BER in a video system to stay below 10^{-10} . Consider two different sources within the system whose output SDI signals contain different amounts of random and deterministic jitter. At a particular receiver's input, suppose the total jitter in the two signals has the same RMS amplitude and generates the Bathtub curves shown in Figure 12.

The shapes of the Bathtub curves offer insight into the signal jitter. The steeper curve on the signal from Source A indicates a lower amount of random jitter compared to the signal from source B. As the number of bits observed increases, the peak-to-peak jitter amplitude increases less in the signal from source A than in the signal from Source B. Since the total jitter in the signals have equal RMS jitter amplitudes, the ratio of deterministic jitter to random jitter is greater in the signal from Source A compared to the signal from Source B.

For a BER of 10^{-10} , the sides of the Bathtub curve for the SDI signal from Source A define a 0.5 UI region centered in the unit interval. Presuming that any signal transition in this region causes a decoding error, we can say that the Eye opening for this signal equals 0.5 UI except for 1 transition in 10^{10} bits. By contrast, the Eye opening for the SDI signal from Source B equals 0.33 UI except for 1 transition in 10^{10} bits.

To meet the 10^{-10} BER target, the receiver must sample the SDI signal from Source B inside a 0.33 UI region around the midpoint of the unit interval. The receiver has greater margin in sampling the signal from Source A. It can sample this

signal anywhere inside a 0.5 UI region centered in the unit interval.

As described in section 2.5, receivers track signal jitter at frequencies below the bandwidth of their clock recovery process and can adjust the sampling location to compensate for this variation. However, clock recovery cannot track these variations perfectly.

Suppose that timing errors in the clock recovery process could cause the sampling location of the receiver used in this example to fall anywhere within a 0.4 UI region centered in the unit interval. Then, signals from source B will most likely not meet the 10^{-10} BER requirement due to the larger random jitter component in these signals.

Signals from Source A can more easily meet this BER requirement. Except for 1 transition in 10^{10} bits, the Eye opening in the SDI signals from Source A is greater than the potential variation in the receiver's sampling location. This includes some margin to allow for small, occasional increases in internal jitter or variation in sampling location.

The primer "Understanding and Characterizing Timing Jitter" listed in the References contains additional information about Bathtub plots and the impact of random and deterministic jitter.

3.0 Specifications on Video Jitter Performance and Measurement

Document	Title	Content description
SMPTE RP 184	Specification of Jitter in Bit-Serial Digital Systems	Methods and performance templates for specifying jitter input tolerance, jitter transfer, and output jitter.
SMPTE RP 192	Jitter Measurement Procedures in Bit-Serial Digital Interfaces	Methods for carrying out the jitter performance measurements identified in RP 184.
SMPTE 259M	10-Bit 4:2:2 Component and $4f_{sc}$ Composite Digital Signals—Serial Digital Interface	Specifications on performance limits for jitter at the SDI outputs of SD-SDI signal sources.
SMPTE 292M	Bit-Serial Digital Interface for High-Definition Television Systems	Specifications on performance limits for jitter at the SDI outputs of HD-SDI signal sources.
SMPTE EG 33	Jitter Characteristics and Measurements	Guidance on jitter measurement and minimizing jitter in video systems.
IEEE Std 1521	IEEE Trial-Use Standard for Measurement of Video Jitter and Wander	Specifications for output jitter and wander only, including performance templates, and methods for measuring jitter, including jitter measurement frequency response.

▶ **Table 1.** Standards and other documents that apply to video jitter.

Consistency in jitter measurements necessarily starts with the standards. The industry develops and adopts these standards to ensure that equipment will perform satisfactorily in video production, distribution, and transmission systems. Video equipment manufacturers must design and deliver products that meet these standards. Video test equipment manufacturers must fully understand the standards, implement test procedures that conform to the requirements documented in these standards, and make these implementations as accurate as possible within the constraints of their specific implementations.

However, implementing test procedures in conformance to the relevant video standards does not ensure consistent measurements. In particular, the current video standards allow for significantly different jitter measurement methods that can yield noticeably different results. Hence, any discussion of jitter measurement and variability in measurement results must begin by looking at the relevant standards and specifications.

3.1. Standards documents

SMPTE publishes standards, recommended practices (RP), and engineering guidelines (EG) for the video industry. The Institute of Electrical and Electronics Engineers (IEEE) also publishes video standards. Table 1 lists the standards and recommended practices that apply to video jitter and briefly describes their jitter-related content.²

RP 184 gives the framework for specifying jitter performance, including jitter input tolerance, jitter transfer, and output jitter. This includes methods for specifying the jitter frequencies included in peak-to-peak amplitude measurements. This recommended practice only describes the form of jitter specifications. All parameters are in symbols without specific performance limits.

In particular, RP 184 does not give values for measurement bandpass cutoff frequencies or peak-to-peak jitter limits. These measurement parameters depend on the particular SDI format and are listed in the standard defining the format. Also, RP 184 defers specification on measurement time to other standards or recommended practices.

RP 192 gives examples of jitter measurement techniques that conform to RP 184 and describes these particular techniques in detail. However, RP 192 does not preclude other techniques that conform to RP 184. This recommended practice does not specify particular measurement times, but does describe a procedure for determining the minimum measurement time for oscilloscope-based jitter measurement.

SMPTE 259M, section 3.5, deals with jitter in SDI signals carrying standard-definition digital video content. SMPTE 292M, section 8.1.8, deals with jitter in SDI signals carrying high-definition digital video content. For their respective formats, these standards specify the performance limits

² The ITU also publishes video standards containing specifications on jitter performance, e.g., ITU-R BT.656, ITU R-BT.799, and ITU-R BT. 1363. In Japan, the ARIB standards contain specifications in this area. To a significant extent, the guidelines and specifications in these documents agree with those in the SMPTE and IEEE documents described in this guide.

Jitter Measurement for Serial Digital Video Signals

► Primer

on jitter from “the serial output of a source derived from a parallel domain signal whose timing and other characteristics meet good studio practices.”

Hence, these standards define performance limits only on output jitter. In particular, they assign specific values for the parameters identified in RP 184 for measuring output jitter. These include the measurement bandpass corner frequencies, peak-to-peak jitter limits, and the test signal to use in making jitter measurements. These standards do not specify a peak-to-peak amplitude measurement time.

EG 33 gives engineers more detailed information on jitter in SDI signals and guidance on jitter measurement techniques. It describes some of the impacts jitter can have on system operations and suggests design approaches that minimize or mitigate these impacts.

IEEE Standard 1521 describes requirements for specifying the measurement of jitter and wander for both analog and digital video. As with RP 184, it gives only the form of the specification. It does not give values for measurement filter corner frequencies or peak-to-peak jitter limits. It also describes three methods for making jitter and wander measurements.

In this technical guide, we consider only the measurement of output jitter. The video standards specify performance limits only on this type of jitter. These are the most commonly performed measurements, and they have generated the greatest confusion.

3.2. Specifications on jitter frequency bandpass

As described in section 2.5, video jitter is classified based on frequency. To measure the amount of jitter in these different classes, measurements must be restricted to specific frequency ranges. RP184, RP192, and IEEE Std. 1521 all contribute specifications on bandpass shapes. The relevant SDI specification gives the bandpass corner frequencies.

As an example, Figure 13 shows the bandpass for measuring timing jitter in an HD-SDI signal. The values shown in the figure combine the specifications from all relevant standards and recommended practices.

SMPTE 292M specifies the low-frequency cutoff at $f_1 = 10$ Hz, consistent with the definition of timing jitter. It specifies that the high-frequency cutoff, f_4 , shall be $> 1/10$ the clock rate, which equals 148.5 MHz for HD-SDI signals.

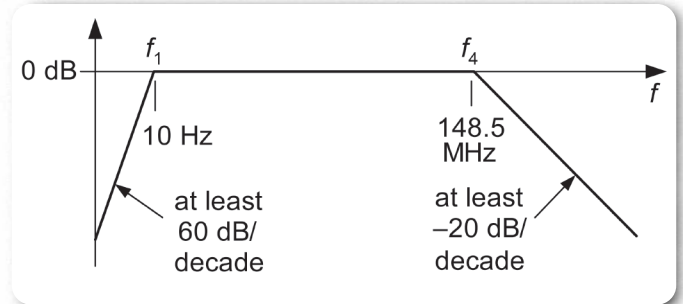

► **Figure 13.** Frequency bandpass for measuring timing jitter in an HD-SDI signal.

RP 184 recommends at least a 20 dB/decade slope on the highpass filtering at f_1 . RP 192 recommends at least a 40 dB/decade slope, and IEEE Std. 1521 recommends at least a 60 dB/decade slope. The IEEE standard requires the steeper 60 dB/decade slope to separate jitter from wander (See Figure 1 in IEEE Std. 1521). To conform to the IEEE standard and both recommended practices, jitter measurement equipment must use at least a 60 dB/decade highpass ramp, as shown in Figure 13.³

RP 184 recommends at least a -20 dB/decade slope on the lowpass filtering at f_4 . It also recommends an in-band ripple less than ± 1 dB, but does not give any guidance on the accuracy of the highpass corner frequency, f_1 . The lowpass corner frequency, f_4 , can have any value above $1/10$ the clock rate.

To determine the amount of alignment jitter we also need to measure over a range of frequencies, but one with different highpass corner frequency and slope (Figure 14).

SMPTE 292M specifies the low-frequency cutoff for measuring alignment jitter as $f_3 = 100$ kHz. In agreement with the timing jitter specification, it requires that the high-frequency cutoff, f_4 , shall be at least $1/10$ the clock rate.

Specifications of the highpass corner frequency in the bandpass for measuring alignment jitter reflect expectations about the bandwidths of clock recovery processes that track low frequency jitter.

³ Based on discussions currently underway, the recommendation in RP 184 and RP 192 for the highpass slope will likely change to at least 60 dB/decade.

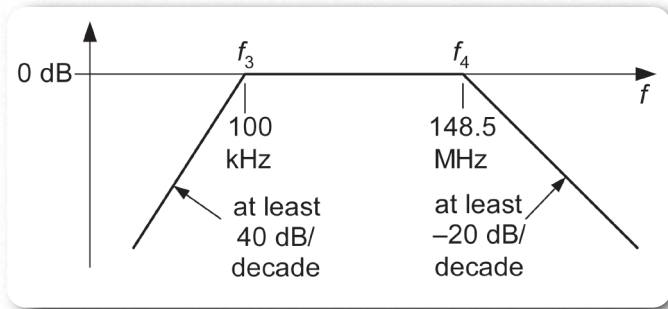

▶ **Figure 14.** Frequency bandpass for measuring alignment jitter in an HD-SDI signal.

SMPTE selected the value for f_3 shown in Figure 14 with the expectation that equipment handling HD-SDI signals will have clock recovery bandwidths of at least 100 kHz. Equipment handling SD-SDI signals may have smaller clock recovery bandwidths, especially legacy equipment. Hence, SMPTE 259M specifies that $f_3 = 1$ kHz in the bandpass for measuring alignment jitter in SD-SDI signals.

RP 184 recommends at least a 20 dB/decade slope on the highpass filtering at f_3 , while RP 192 recommends at least a 40 dB/decade slope. To conform to both recommended practices, jitter measurement equipment must use at least a 40 dB/decade high-pass slope, as shown in Figure 14.⁴ RP 184 recommends at least a -20 dB/decade slope in the low-pass filtering at f_4 . As with timing jitter, RP 184 recommends an in-band ripple less than ± 1 dB and does not give any guidance on the accuracy of the highpass corner frequency, f_3 . The lowpass corner frequency in the bandpass for measuring alignment jitter, f_4 , can have any value greater than 1/10 the clock rate.

3.3. Specifications on signal voltage levels and transition times

For SD-SDI outputs, SMPTE 259M specifies a peak-to-peak signal amplitude of 800 mV \pm 10% with a DC offset equal to 0.0 V \pm 0.5V. The transition between voltage levels can take no less than 0.4 ns and no more than 1.5 ns, and the rise and fall times cannot differ by more than 0.5 ns.

For HD-SDI outputs, SMPTE 292M specifies the same signal amplitude conditions. The transition between voltage levels can take no more than 270 ps, and the rise and fall times cannot differ by more than 100 ps.

Hence, the SMPTE standards allow asymmetric rise and fall times in SDI signals and significant DC offsets. As noted in section 2.9, these signal characteristics can impact decoding. They can also impact jitter measurement, as we describe in section 4.2.

3.4. Specifications on connecting cables and other system elements

For SD-SDI signals, SMPTE 259M specifies that measurements of source output signal characteristics shall be made across a resistive load connected by a “short coaxial cable.” For HD-SDI signals, SMPTE 292M specifies a “1-m coaxial cable.” Hence, for both SD- and HD-SDI signals, the standards only specify jitter performance near the source output as measured over a short cable length.

For SDI signal receivers, the standards place some requirements on the SDI inputs, including impedance and return loss. They do not, however, define any performance limits on the jitter input tolerance of an SDI receiver. Also, the standards do not define performance limits on jitter transfer in system elements.

The standards do not specify particular cable types, but both do require that coaxial connections have the $1/\sqrt{f}$ frequency response needed for the correct operation of cable equalizers. For HD-SDI signals, SMPTE 292M goes somewhat further and specifies the cable return loss.

Neither standard places performance limits on the data-dependent jitter introduced by ISI on long cables. They do say the receivers should nominally operate with cable losses up to 20 dB at one-half the clock frequency. This is not a performance limit, however, as they also say that “receivers that operate with greater or lesser signal attenuation are acceptable.” The standards do not specify performance characteristics on other sources of ISI in video systems, including reflections on connectors in patch panels.

⁴ Based on discussions currently underway, the recommendation in RP 184 for the high-pass slope will likely change to at least 40 dB/decade.

Jitter Measurement for Serial Digital Video Signals

► Primer

3.5. Specifications on peak-to-peak jitter amplitude

SMPTE 292M specifies that the timing jitter in the HD-SDI output of a source derived from a parallel domain signal will have peak-to-peak amplitude less than 1.0 UI (673 ps). It also specifies that the alignment jitter in the SDI output will have peak-to-peak amplitude less than 0.2 UI, which equals 135 ps (0.2×673 ps).

SMPTE 259M specifies that both the timing and the alignment jitter in the SD-SDI output of a source derived from a parallel domain signal will have peak-to-peak amplitude less than 0.2 UI, which equals 740 ps (0.2×3.7 ns).

Note that these two standards only specify the maximum peak-to-peak amplitude of output jitter allowed in the SDI signal at the output of a source that derives this signal from a parallel domain input. They do not specify the maximum peak-to-peak amplitude of output jitter allowed in SDI signals at the output of devices that derive the output signal directly from an SDI input.

3.6. Specifications on measurement time

The measured peak-to-peak jitter amplitude depends on the time interval used to make the measurement. Section 2.6 describes this dependency for random jitter. It also applies to peak-to-peak jitter amplitude measurements made on signals containing deterministic jitter. Figure 15 gives a simple illustration of this dependency.

In this example, the SDI signal contains periodic, deterministic alignment jitter that consists of well-separated pulses. One advances transitions from their ideal positions; the other delays transitions. An instrument that makes the peak-to-peak measurement over a 50 ms observation window will only measure a single jitter peak and will indicate that the signal has 0.15 UI of alignment jitter peak-to-peak. This amount of jitter is within the specified performance limit. However, an instrument that makes the peak-to-peak measurement over 150 ms will detect both the advance and delay peaks. This instrument will indicate that the signal has 0.3 UI of alignment jitter peak-to-peak, above the specified performance limits.

While SDI signals can have deterministic jitter behavior of the kind shown in Figure 15, it is not a typical pattern. However, all SDI signals have some amount of random jitter. As noted in section 2.6, random jitter can be modeled by a Gaussian probability distribution of jitter amplitudes and, for all practical purposes, does not have an upper bound on peak-to-peak jitter amplitude. Extending the time interval for

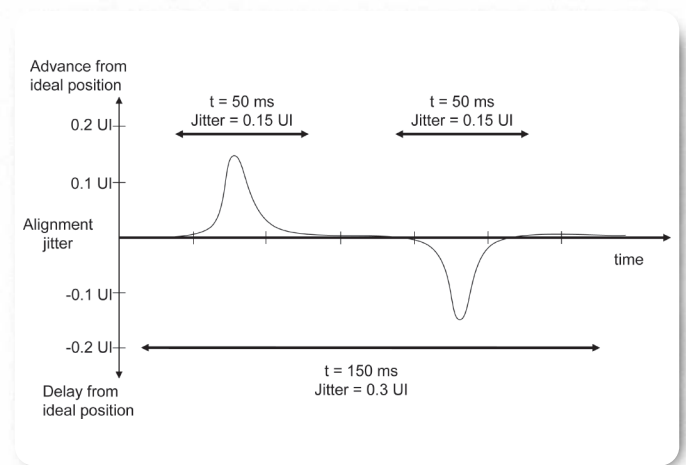

► **Figure 15.** Peak-to-peak measurement value depends on measurement time.

the peak-to-peak measurement increases the probability that some larger amplitude variations will occur during the measurement period, which increases the measured peak-to-peak jitter amplitude. We examine these effects in more detail in section 4.5.3.

As noted in section 3.1, the standards offer very limited guidance on peak-to-peak measurement time. Thus, different manufacturers of video jitter measurement equipment can, and do, measure the peak-to-peak jitter amplitude over different time intervals. Variations in measurement time typically lead to discrepancies in the measured values. To enable greater consistency in measuring peak-to-peak jitter amplitude, the standards will need to specify measurement times.

	Specification		Signal format	
			SD-SDI	HD-SDI
Bandpass for measuring timing jitter	Highpass characteristics	Corner frequency	10 Hz	10 Hz
		Slope	At least 60 db/decade	At least 60 db/decade
	Lowpass characteristics	Corner frequency	> 1/10 clock rate	> 1/10 clock rate
		Slope	At least -20 db/decade	At least -20 db/decade
	Bandpass ripple		± 1 dB	± 1 dB
Bandpass for measuring alignment jitter	Highpass characteristics	Corner frequency	1 kHz	100 kHz
		Slope	At least 40 db/decade	At least 40 db/decade
	Lowpass characteristics	Corner frequency	> 1/10 clock rate	> 1/10 clock rate
		Slope	At least -20 db/decade	At least -20 db/decade
	Bandpass ripple		± 1 dB	± 1 dB
Voltage and transition times	Peak-to-peak signal amplitude		800 mV ± 10 %	800 mV ± 10 %
	DC offset		0.0V ± 0.5 V	0.0V ± 0.5 V
	Maximum transition time		0.4 ns	Not specified
	Minimum transition time		1.5 ns	270 ps
	Maximum difference between rise and fall times		0.5 ns	100 ps
Peak-to-peak jitter amplitude	Timing jitter		0.2 UI	1.0 UI
	Alignment jitter		0.2 UI	0.2 UI
Recommended test signal			Color bars	Color bars

► **Table 2.** Summary of jitter specifications.

3.7. Specifications on data patterns

RP184 also recommends that jitter specifications identify the test signal used for the jitter measurement. Both SMPTE 259M and SMPTE 292M specify color bars as a non-stressing test signal for jitter measurement. They caution that using a stressing signal with a long run of zeros can give misleading results.

In particular, the SDI checkfield defined in SMPTE RP 198 will generate pathological signals for stress testing hardware-based equalization and clock recovery processes that contain long intervals of constant signal voltage. Suppose that the method used to measure jitter on a source output includes such clock extraction or equalization processes. While these processes always contribute some small level of internal jitter, the pathological signals can increase this internal jitter significantly, which can increase the measured peak-to-peak amplitude value relative to SDI signals with more typical characteristics.

While pathological signals are quite valuable in stress testing, tests to verify that a signal source conforms to SMPTE jitter specifications should not use these signals. Methods that use an external reference rather than clock extraction could successfully measure jitter on pathological signals. However, as noted in SMPTE RP 192, these methods only give a “coarse survey of jitter in an SDI signal.” The measurement result “depends on the stability of the reference signal” and “does not allow bandwidth restriction as generally required in jitter specification.”

3.8. Summary of jitter specifications

Table 2 summarizes the specifications relevant to measuring and characterizing SDI signal jitter.

4.0 The Functions Comprising Jitter Measurement

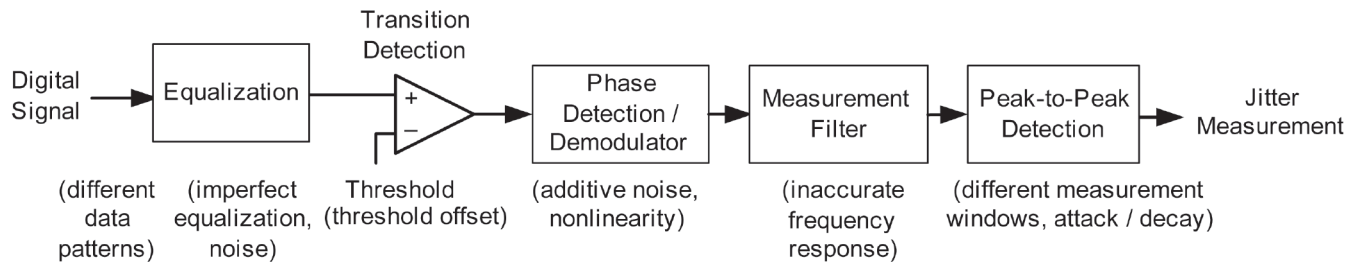

► **Figure 16.** The functions involved in jitter measurement (Causes of measurement discrepancies are indicated in parentheses).

To understand how different instruments can yield different jitter measurements, we have to enumerate the functions involved in jitter measurement, i.e. all the places where differences can occur. Figure 16 shows a generic block diagram of a jitter measurement process.

This diagram is a reasonable representation of hardware-based jitter measurement processes implemented in many video-specific measurement instruments. However, it does not fully represent any specific method. Also, this diagram does not correspond to the jitter measurement processes used in general-purpose oscilloscopes, especially software-based approaches. Primarily, we use it as a convenient organizing structure for describing the jitter measurement process.

4.1. Equalization

As described in section 3.4, the SMPTE standards specify that measurements of a source output should be made over short cable lengths. At these lengths, cable attenuation will not impact the jitter measurement.

However, this is not the case when making measurements to diagnose jitter-related problems in a video system. In this case, engineers are typically measuring jitter in SDI signals at the end of a long cable. Due to frequency-dependent cable attenuation, these SDI signals will have intersymbol interference that will appear as data-dependent jitter if the signal is not equalized.

If the method used to measure the jitter in this SDI signal does not have an equalization stage, the measured peak-to-peak value will include the jitter introduced by ISI due to cable length. However, because SDI receivers have cable equalizers (see section 2.7), this jitter will typically not result in decoding errors. In effect, the non-equalized measurement result will include a jitter component that does not lead to decoding errors.

To address this issue, some waveform monitors and other video measurement instruments include an equalization step in the jitter measurement process as shown in Figure 16. The peak-to-peak jitter amplitude measured after equalization will better reflect jitter components that can affect the receiver's performance. The measurement will not include jitter components that the receiver's equalizer will remove.

Differences in the cable equalizer used in the equalization stage can introduce differences in jitter measurement results. Specifically, equalizers differ in their ability to compensate for cable-related ISI. When measuring jitter in SDI signals at the end of long cables, data-dependent jitter due to imperfect equalization can increase the peak-to-peak jitter amplitude measurement compared to a measurement made with a better equalizer. While noticeable, the differences in peak-to-peak jitter amplitude measurements due to imperfect equalization are much smaller than the differences between equalized and non-equalized measurements.

When measuring jitter in an SDI source output over a short cable, an equalization stage can affect peak-to-peak amplitude measurements. Noise in the equalization process can add jitter to the SDI signal that can increase the measurement result. Typically, equalization noise adds only a small amount of jitter, though it can make a noticeable contribution to the jitter noise floor (see section 4.6).

Equalization can also affect jitter measurements when the SDI signal has long intervals at constant voltage, e.g., pathological signals. As noted in section 2.8, these signal characteristics stress the equalization process. In this case, equalization-related effects can impact peak-to-peak jitter amplitude measurements made over cables of any length.

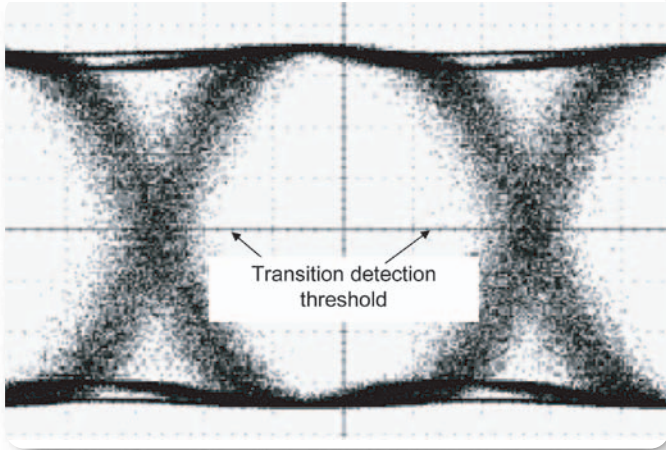

▶ **Figure 17.** Eye diagram of signal with equal rise and fall times showing optimum decision threshold for transition detection at the 50% point.

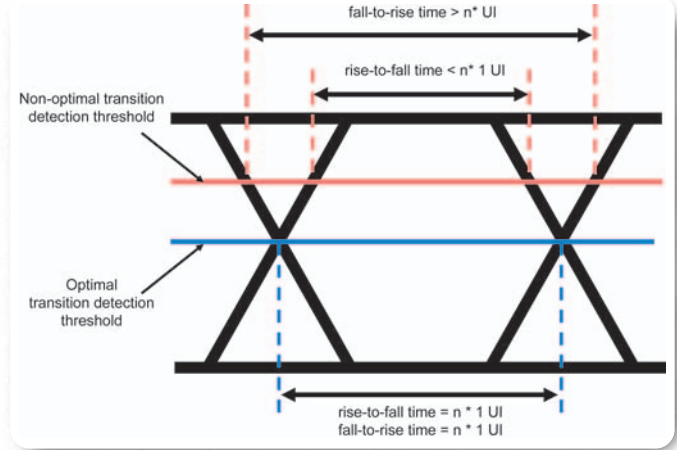

▶ **Figure 18.** Non-optimal decision threshold introduces duty cycle dependent jitter.

Because the standards focus on jitter performance at the serial output of an SDI source, they do not give any guidance on the use of equalization or any specifications for equalization methods. While jitter measurement has a key role in evaluating video source equipment, it has an equally critical role in deploying and maintaining highly reliable production, distribution and broadcast systems. Hence, the standards will need to address equalization in jitter measurement methods to ensure measurement accuracy and consistency in this application.

4.2. Transition detection

As noted in section 2.3, jitter is the variation of signal transitions from their ideal positions in time. To measure these variations, the measurement process needs to determine the point in time when an actual signal transition occurs. Like signal decoding, it uses a decision threshold in this transition detection process.

The time separation between ideal positions equals a multiple of the unit interval. Hence, the optimal decision level for transition detection would ensure that the time separation of actual transitions in a jitter-free signal would also equal multiples of a unit interval.

For transitions with equal rise and fall times, this optimal decision level equals the 50% point in the transition. This threshold falls on the crossover points in the Eye diagram for these signals and equals the level where the Eye has the maximum width (Figure 17).

Using a non-optimal decision threshold in transition detection introduces jitter. Figure 18 illustrates this effect using a schematic representation of the Eye diagram for a jitter-free

signal whose transitions have equal rise and fall times. A transition detector using the optimal decision threshold located midway between the signal levels (blue line) would locate both rising and falling edges at the Eye crossover points. The time between any rising edge detection and the detection of the subsequent falling edge will always equal some multiple of the unit interval. The time between any falling edge detection and the detection of the subsequent rising edge will also equal a multiple of the unit interval.

Now consider a transition detector using a non-optimal decision threshold located closer to the high signal level (red line). When the signal had a rising edge followed by a falling edge, this transition detector would locate the rising edge after the crossover point and the corresponding falling edge before the crossover point. The time between these two edges would be less than the appropriate multiple of the unit interval.

When the signal had a falling edge followed by a rising edge, this transition detector would locate the falling edge before the crossover point and the corresponding rising edge after the crossover point. The time between these two edges would be greater than the appropriate multiple of the unit interval.

Because of the non-optimal decision threshold, the detected transitions vary from their ideal positions. This non-optimal transition detection process has introduced a deterministic jitter component called *duty-cycle dependent jitter*.

Jitter Measurement for Serial Digital Video Signals

► Primer

Using the optimal decision threshold in transition detection will yield a smaller jitter measurement since the measured value does not include duty-cycle dependent jitter arising from a non-optimal level. Hence, we can say that the optimal decision threshold for transition detection is the level that minimizes jitter and maximizes Eye width.

Most measurement instruments have AC-coupled inputs and set the decision threshold for transition detection to the average signal voltage of the AC-coupled signal. In most cases, this approach results in near-optimal transition detection because typical SDI signals are symmetric “in the long term” (see section 2.9). Over durations equal to many unit intervals, the signal spends nearly the same amount of time at each voltage level. The average signal voltage over these durations lies close to optimal position for transition detection at the midpoint of the Eye height (Figure 17).

The AC-coupling effects described in section 2.9 can affect jitter measurement as well as signal decoding. In particular, long constant-voltage intervals in an SDI signal can shift the signal relative to a fixed decision threshold (see Figure 6). The near-optimal decision threshold for a symmetric SDI signal with many transitions becomes a non-optimal decision threshold for a shifted signal with long constant voltage intervals. In this case, the transition detection stage in the jitter measurement introduces duty-cycle dependent jitter.

In the short term, typical SDI signals can spend several unit intervals at the same signal level. Generally, measurement instruments adequately compensate for AC-coupling effects related to this short-term behavior. So, for most SDI signals, the transition detection stage does not introduce enough duty-cycle dependent jitter to affect the peak-to-peak amplitude measurement.

Equalizer stress patterns in pathological SDI signals can introduce significant shifts in the AC-coupled signal (see Figure 10). In this case, duty-cycle dependent jitter introduced in the transition detection stage could increase the peak-to-peak jitter amplitude measurement.

These effects support SMPTE’s caution against using stress patterns in measuring output jitter in SDI signal sources. The recommended color bar pattern generates an SDI signal with frequent transitions. After AC-coupling, the average voltage level in this signal will closely match the optimal decision threshold for transition detection.

Non-symmetric transitions can also impact jitter measurement. Although most SDI signals have nearly symmetric transitions times, the standards allow a significant difference

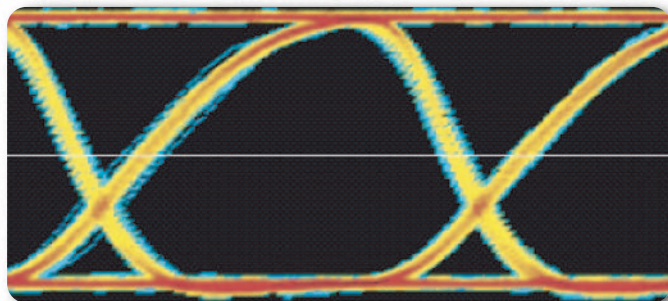

► **Figure 19.** Acceptable SDI signal with slow rise time and a fast fall time shows the 50% point does not always equal the optimal decision level for transition detection.

in rise and fall times. Figure 19 shows an SDI signal that conforms to the standard but has a slow rise time and a fast fall time. The Eye crossover points appear well below the 50% point in the transition.

If the transition detection stage in a jitter measurement process used a decision level equal to the 50% point in the transition, the measurement results would include a significant amount of duty-cycle dependent jitter. A jitter measurement method that could align the decision threshold with the Eye crossover points (maximum Eye width) would give a smaller result (minimal jitter).

The standards do not give any guidance regarding the decision threshold for the transition detection stage in the jitter measurement process. In particular, they do not have specifications on compensating for AC-coupling effects or accommodating non-symmetric signal transitions.

While differences in transition detection are not a primary source of difference in jitter measurement, additional guidance will help ensure more consistent results. Appropriate specification in this area reduces the potential for inconsistent measurement results due to duty-cycle dependent jitter arising from non-optimal transition detection.

4.3. Phase detection/demodulation

As noted in section 2.3, we will view jitter as a phase modulation of the serial data stream. The phase detection/demodulation stage in the jitter measurement process separates this phase modulation from the input signal using one of two basic approaches:

- Sampling the phase modulation in the input signal by collecting individual amplitude measurements of the phase variation in signal transitions.
- Using demodulation techniques to generate a *demodulated jitter signal* that corresponds to the phase modulation in the input signal.

In the following sections, we will describe the characteristics of three methods used in this stage of the jitter measurement process:

- The *Equivalent-time Eye method* constructs an Equivalent-time Eye diagram of the signal and measures the amount the edge samples in the Eye vary from their ideal positions.
- The *Phase Demodulation method* applies two appropriately filtered clock signals to a phase detector. The output from the phase detector is the demodulated jitter signal.
- The *Real-time Acquisition method* applies signal processing algorithms to one or more acquisition records captured in real-time from single trigger events to measure the amount each signal edge in the acquisition record varies from its ideal position.

Video-specific measurement instruments commonly use the first two methods listed. We include a description of the third method to briefly touch on some aspects of using real-time oscilloscopes to measure jitter in SDI signals.

These general descriptions will cover some key characteristics of these methods that can introduce differences in jitter measurements. They are not in-depth reviews of measurement techniques or the capabilities and performance of specific instruments. Rather, they identify some key factors to consider when comparing jitter measurement made by different instruments.

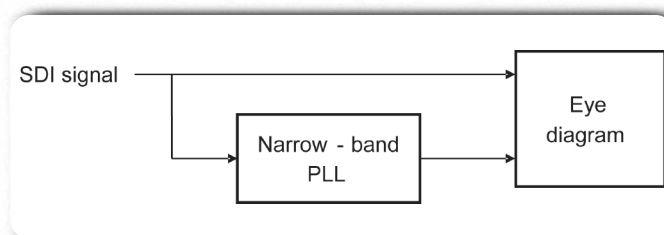

► **Figure 20.** *Equivalent-time Eye method.*

4.3.1. Phase detection/demodulation: Equivalent-time Eye method

Figure 20 illustrates the Equivalent-time Eye method. While this diagram reasonably represents implementation of this method in video-specific measurement instruments, it does not represent jitter measurement in sampling oscilloscopes or other general-purpose instruments that use equivalent-time sampling. Current-generation sampling oscilloscopes and signal analyzers use significantly more sophisticated techniques in implementing jitter measurement processes, often with extensive software-based signal processing. Hence, the following description does not reflect the capabilities and performance of these instruments.

Jitter Measurement for Serial Digital Video Signals

► Primer

Operation and frequency response

This method uses a recovered clock to form an Equivalent-time Eye diagram of the input SDI signal. This recovered clock tracks jitter frequencies below the loop bandwidth of the narrow-band phase-lock loop (PLL), f_{nb} .

This low frequency jitter in the recovered clock compensates for the corresponding low frequency jitter in the input signal. As a result, the Eye diagram only contains jitter with spectral components above f_{nb} . With the proper configuration (see section 4.4.1), the narrow-band PLL can realize the highpass characteristics specified for measuring timing jitter (Figure 13) or alignment jitter (Figure 14).

To make an automated jitter measurement, the instrument detects signal samples in the Equivalent-time Eye that lie close to the decision threshold used for transition detection. For each sample, it then computes the time difference between the signal sample and the Eye crossover point. The signal sample corresponds to an actual edge position and the Eye crossover point corresponds to an ideal edge position. The computed difference equals the amount of phase variation in an actual signal edge, or equivalently, a sample of the signal jitter. The instrument builds a histogram of these jitter amplitude measurements over some number of edge samples and reports the width of this histogram as the peak-to-peak jitter amplitude.

Figure 21 shows an Equivalent-time Eye pattern created by using this method on an HD-SDI signal. It also shows a typical histogram of jitter amplitude measurements and the associated collection window. In this example, the histogram width equals 187 ps. The unit interval for an HD-SDI signal equals 673 ps. So, the measured peak-to-peak jitter amplitude for this signal is $187/673 = 0.278$ UI.

Transition detection

In the Equivalent-time Eye method, transition detection occurs when the instrument selects the Eye samples used in the jitter amplitude measurements. To avoid adding duty-cycle dependent jitter to the peak-to-peak jitter amplitude measurement, the histogram collection window should align with the optimal decision threshold for transition detection (see section 4.2). Further, the height of the histogram window should not exceed 5% of the Eye height. Otherwise, the measurement process will include edge samples from the upper and lower portions of the Eye where the finite rise and fall times of signal transitions introduce duty-cycle dependent jitter (see section 4.2).

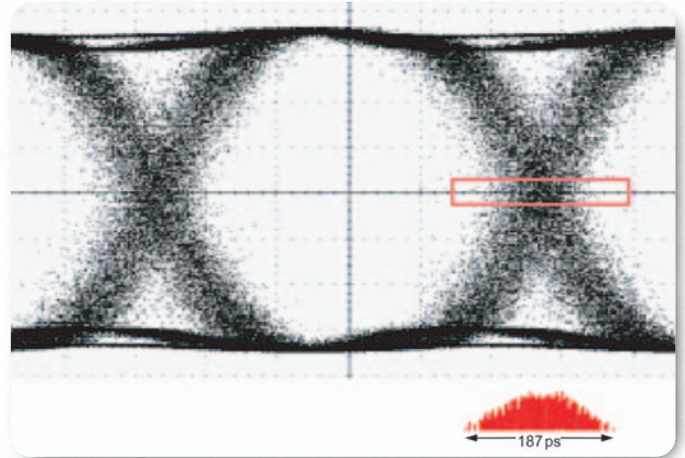

► **Figure 21.** Histogram measurement of peak-to-peak jitter.

For symmetric SDI signals, vertically centering the histogram window in the middle of the Eye diagram will generally produce optimal transition detection. For SDI signals with non-symmetric rise and fall times, the crossover points are not vertically centered in the Eye (Figure 19). For these signals, a peak-to-peak jitter amplitude measurement made with a histogram window centered in the middle of the Eye will contain some duty-cycle dependent jitter. The measured value will be larger than a measurement made with a histogram window centered on the optimal decision level that passes through the crossover point of the Eye.

Unless the measurement process compensates for AC-coupling effects, the Eye diagram can shift from its nominal position (see section 2.11). With a histogram collection window fixed in the middle of the nominal Eye diagram, these shifts will introduce duty-cycle dependent jitter. Even with compensation, pathological SDI signals with equalizer stress patterns can significantly shift the Eye diagram and add duty-cycle dependent jitter that increases the peak-to-peak jitter amplitude measurement. In Equivalent-time Eye diagrams, the presence of “flyer” points outside the main Eye diagram indicates that AC-coupling effects have shifted the signal levels.

Dynamic range

The Equivalent-time Eye method computes variations in transition times with respect to the nearest Eye crossover point, not with respect to the actual transition in the signal. Thus, the absolute value of these variations cannot exceed 0.5 UI, even if some of the samples actually came from transitions that varied more than 0.5 UI from their ideal positions. Hence, the method shown in Figure 20 cannot quantify jitter with peak-to-peak amplitude greater than 1 UI.

SMPTE RP 192 describes an alternative to the method shown in Figure 20 that can measure peak-to-peak jitter amplitudes above 1 UI. However, this method does not use the input signal to create the Eye diagram. Instead, it replaces the input signal with a second extracted clock signal. We will briefly describe this method in section 4.3.2 since it shares some characteristics with the Phase Demodulation method.

Sampling, sampling rate, and coverage

The collection rate for the histogram of jitter amplitude measurements falls well below the Equivalent-time Eye sampling rate. Since the measurement process needs to use a small histogram window to avoid adding duty-cycle dependent jitter to the peak-to-peak amplitude measurement, only a small percentage of the Eye samples will fall within the collection window.

For example, suppose that only 2.5% of the Eye samples fall inside the histogram window. If the instrument adds samples to the Equivalent-time Eye diagram at a 10 MS/s rate, the measurement process would collect histogram values at a rate of 250 kS/s. Thus, the histogram collection process corresponds to a low-rate sampling of the signal jitter. As a result, long observation times may be necessary to fill out a histogram that adequately captures the peak-to-peak jitter amplitude.

Signal displays

A single histogram collected as described in this section contains samples of jitter from widely separated signal edges. Jitter waveform or spectrum displays cannot be meaningfully constructed from these histogram values.

The Eye display allows some qualitative assessment of jitter behaviors. The Eye closure indicates the peak-to-peak jitter amplitude, and patterns in the Eye display may indicate the presence of deterministic jitter.

Manual measurements

To make a manual jitter measurement, vertical cursors are placed on the signal samples that are:

- Lying on, or very close to, a line connecting the Eye crossover points (optimal decision threshold)
- Farthest to the left and right of a crossover point during a given time period

The difference between the cursor readings divided by the unit interval equals the peak-to-peak jitter amplitude in UIs. Because of the low density or visibility of samples with large jitter amplitudes, it may be difficult to place cursors at the full extent of the signal jitter.

Jitter Measurement for Serial Digital Video Signals

► Primer

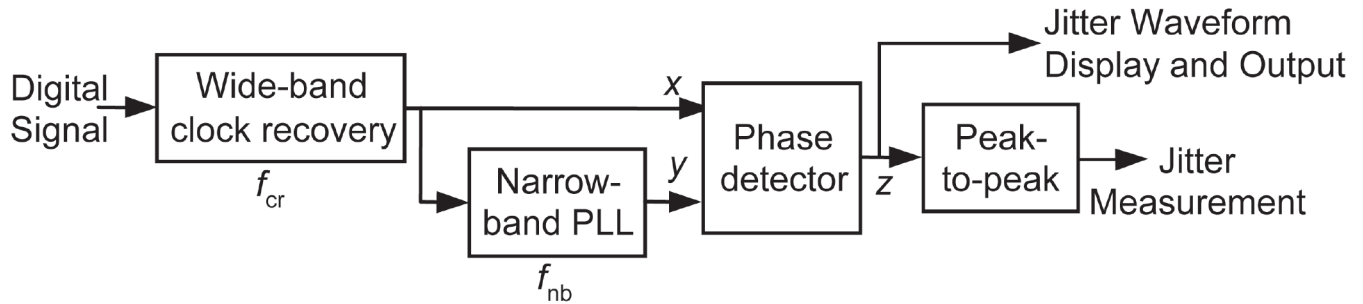

► **Figure 22.** Phase Demodulation method.

4.3.2. Phase detection/demodulation: Phase Demodulation method

Figure 22 illustrates the Phase Demodulation method.

Operation and frequency response

A wide-band clock recovery circuit extracts clock x from the digital signal. This clock tracks the jitter in the input signal up to the clock recovery bandwidth, f_{cr} . A narrow-band PLL derives a reference clock y from clock x . Clock y contains only the jitter components with frequencies below f_{nb} . The phase detector creates a signal z proportional to the phase difference between x and y , i.e. the demodulated jitter signal. This signal contains all jitter components with frequencies between f_{nb} and f_{cr} . A subsequent stage measures the peak-to-peak value of signal z .

With proper frequency response the narrow-band PLL will realize the low frequency characteristics of the bandpass defined for measuring timing jitter (Figure 13) or alignment jitter (Figure 14). Alternatively, a high-pass filter inserted between the phase detector and the peak-to-peak measurement stage can implement these required restrictions.

To realize the high frequency bandpass characteristics specified in the SMPTE standards the loop bandwidth of the clock recovery hardware, f_{cr} , would need to be at least 1/10 the clock rate of the SDI signal input. In practice, clock recovery hardware cannot achieve this high loop bandwidth for SDI signals. The loop bandwidth depends on the number of edges in the signal, and typical SDI signals do not have a sufficient number of edges. Reasonably achievable loop bandwidths fall well below 1/10 the data clock rate.

Thus, the Phase Demodulation method cannot realize the high frequency bandpass characteristics specified in the standards. If the input SDI signal contains jitter components with frequencies between f_{cr} and 1/10 the clock rate, the peak-to-peak amplitude measured with this method could be less than a measurement made with a method that fully realized the lowpass characteristics.

Transition detection and dynamic range

In the Phase Demodulation method, transition detection occurs during clock recovery. The issues around non-symmetric signal inputs described in section 4.2 could also affect jitter measurements made with this method.

Although the phase detector has a usable dynamic range of no more than one clock cycle, the Phase Demodulation method can measure peak-to-peak jitter amplitudes greater than 1 UI by dividing the frequency of the x and y clock signals. Frequency division increases the clock period, i.e. the size of the unit interval, but the amplitude of jitter in the clock edges remains the same. With an appropriately selected division ratio, jitter amplitudes much greater than 1 UI with respect to the original clock frequency will correspond to amplitudes below 1 UI with respect to the new clock frequency. The phase detector can now successfully separate the jitter signal from these lower frequency clocks. Rescaling the demodulated jitter signal converts these amplitudes back to the appropriate jitter amplitudes with respect to the actual unit interval.

Sampling, sampling rate and coverage

Earlier-generation implementations of the Phase Demodulation method used analog peak detection to measure the peak-to-peak amplitude of signal z in Figure 22. Later-generation implementations measure the peak-to-peak jitter amplitude of a digital version of the phase detector output (see section 4.5.1). Sampling rates meet the Nyquist criterion of $2 \times f_{cr}$ for this band-limited demodulated jitter signal. At typical sampling rates, this method can collect a large number of jitter samples in a short amount of time.

The Phase Demodulation method continuously monitors the output of the phase detector. The peak-to-peak amplitude measurement will include any intermittent jitter spikes and other occasional or non-periodic jitter behaviors that occur in this signal within the measurement window.

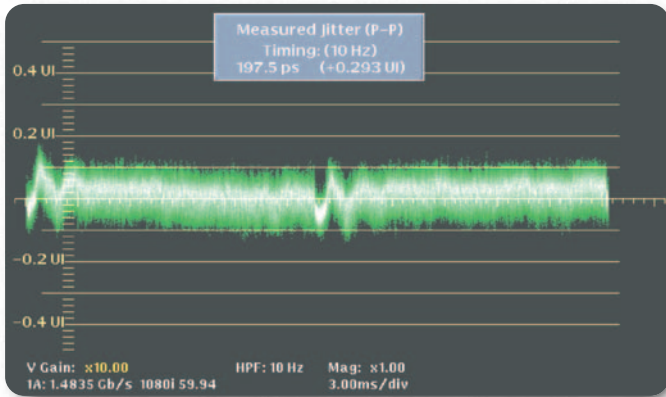

▶ **Figure 23.** Jitter Waveform Display on a Tektronix WFM700M.

Signal displays

As shown in Figure 23, the Phase Demodulation method can present the demodulated jitter signal at the output of the phase detector as a *jitter waveform display*. In this example, the vertical scale shows the jitter amplitude in normalized units (UIs). The sweep rate equals two video fields, and the display clearly shows jitter correlated to the video field rate.

This direct, in-depth view of the jitter signal is especially useful in characterizing jitter performance in video equipment and in diagnosing jitter-related problems in video distribution systems.

Converting the jitter waveform to the frequency domain will yield a *jitter spectrum display*, another valuable tool for understanding jitter. The jitter waveform and spectrum displays created from the phase detector output will contain information on jitter frequencies between f_{nb} and f_{cr} .

Manual measurement

To make a manual jitter measurement, horizontal cursors are placed at the positive and negative peaks of the jitter waveform. The difference between the cursor readings equals the peak-to-peak jitter amplitude in UIs.

As shown in Figure 22, the phase detector output signal is used to form the jitter waveform display and the jitter signal output. This signal contains any internal jitter added by previous stages in the jitter measurement process. Manual peak-to-peak jitter amplitude measurements made using the jitter waveform display will contain this internal jitter. Any displays or measurements made on the jitter signal output will also contain this internal jitter contribution.

When making automated jitter measurements, many instruments subtract a conservative estimate of the jitter noise

floor from the measured peak-to-peak jitter amplitude (see section 4.6). In this case, the automated measurement can be noticeably smaller than its corresponding manual measurement. This difference can arise with any manual peak-to-peak jitter amplitude measurement, not just measurements made on the jitter waveform display available with the Phase Demodulation method.

Measuring jitter amplitudes greater than 1 UI with the Equivalent-time Eye method

As mentioned in section 4.3.1, SMPTE RP 192 describes an alternative Equivalent-time Eye method that can measure peak-to-peak jitter amplitude above 1 UI. Like the Phase Demodulation method, this approach extracts clocks x and y from the input signal and divides their frequency. Instead of using these signals as inputs to a phase detector, this method uses the y clock to trigger an oscilloscope that forms an Eye diagram from the x clock signal. This alternative Equivalent-Eye method can measure peak-to-peak amplitude greater than 1 UI for jitter frequencies between the bandwidth of the narrow-band PLL and the bandwidth of the wide-band clock recovery circuit.

Jitter Measurement for Serial Digital Video Signals

► Primer

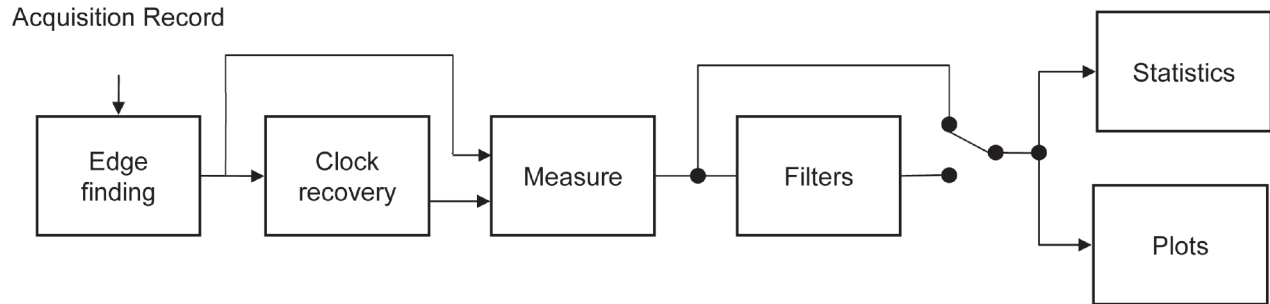

► **Figure 24.** Real-time Acquisition method.

4.3.3. Phase detection/demodulation: Real-time Acquisition method

Figure 24 shows some of the main processes in the Real-time Acquisition method for jitter measurement.

Overview of method and frequency response

An instrument first captures an acquisition record from a single trigger event. Signal processing software detects transitions and extracts a reference clock that defines the ideal positions for transitions in the data signal.

After establishing this reference, the instrument measures the *time interval error* (TIE) for each transition in the data signal, i.e. the difference in time between the actual and ideal positions. The Statistics stage analyzes the collection of TIE measurements and determines various properties. In particular, this stage computes the difference between the maximum and minimum TIE values, which equals the peak-to-peak amplitude of the jitter in the acquisition record with respect to the recovered reference clock.

The signal processing used in extracting the reference clock can implement different clock recovery algorithms. These clock recovery algorithms differ in their ability to exclude wander from timing and alignment jitter measurements. Additional filtering may be needed to realize the highpass filter characteristics shown in Figure 13 and Figure 14.

Acquisition record size also affects this method's frequency response. In particular, it affects timing jitter measurement. For example, suppose an instrument samples an SDI signal at 10 GS/s and stores these samples in a 64 MB acquisition record. This acquisition corresponds to a time interval of 6.4 ms, or slightly more than one period of 160 Hz jitter. A measurement of the peak-to-peak timing jitter amplitude using this record will not include a full cycle of any spectral components in the jitter with frequencies below 160 Hz.

With currently available acquisition record sizes, a single acquisition record can capture the jitter frequencies within the specified bandpass for alignment jitter measurement (Figure 14). Measuring spectral components down to the 10 Hz low-frequency corner specified for timing jitter measurement (Figure 13) requires TIE measurements collected over multiple acquisitions. These TIE measurements will not contain any information about signal jitter in the gaps between acquisitions.

Transition detection and dynamic range

Typically, the parameters used in transition detection and clock recovery can be adjusted. In particular, changing the decision level used in the edge finding process can adjust jitter measurements for non-symmetric SDI signals. Also, the Real-time Acquisition method does not require any special configuration, e.g., clock division, to measure peak-to-peak jitter amplitudes greater than 1 UI.

Sampling, sampling rate and coverage

The TIE measurements correspond to samples of the demodulated jitter signal, although they are not equally-spaced samples of the jitter signal. Figure 25 illustrates the correspondence between TIE measurement and jitter samples.

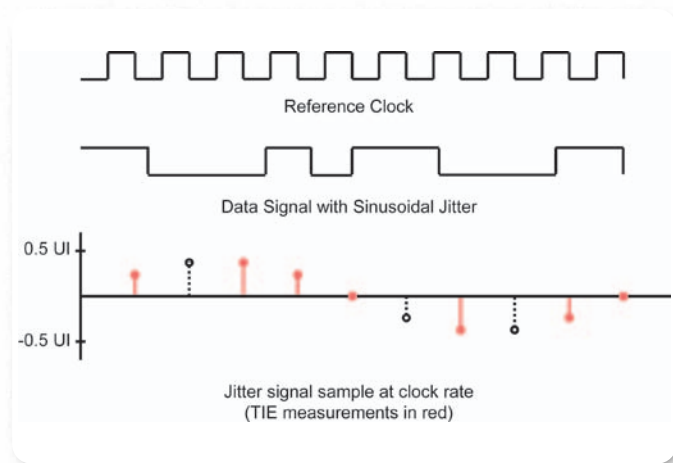

▶ **Figure 25.** TIE measurements and jitter samples.

The figure shows a reference clock, a data signal with sinusoidal jitter, and samples of the jitter signal taken at the clock rate. TIE measurements correspond to the samples shown in red. The samples shown in black, dashed lines have no corresponding TIE measurement because the data signal does not have a transition at this sample point.

The value of these “missing” samples can be interpolated from the actual TIE measurements. The combined set of actual and interpolated TIE measurements correspond to sampling a demodulated jitter signal at the data clock rate. This “effective” sampling rate is well above the Nyquist criteria for spectral components in the jitter signal with frequencies less than 1/10 the data clock rate, i.e. the minimum high-frequency corner point for measuring timing or alignment jitter. At these sampling rates, the Real-time Acquisition method can collect a large number of TIE measurements in a short duration.

The Real-time Acquisition method cannot continuously monitor the jitter signal over durations longer than the time span of a single acquisition record. It can detect any intermittent jitter spikes and other occasional or non-periodic jitter behaviors that occur during an acquisition, but will not capture behaviors that occur during the gaps between acquisitions.

Signal displays and manual measurement

The plotting subsystem shown in Figure 24 can generate several graphical views of the TIE measurements. In particular, this section can produce a time trend plot of the TIE measurements that is equivalent to the jitter waveform display available with the Phase Demodulation method. Applying a Fourier transform to the TIE measurements will yield a jitter spectrum display.

The jitter waveform and spectrum displays contain information on the jitter frequencies that can be adequately captured in a single acquisition record. Because of the gaps between acquisition records, these displays cannot accurately represent low frequency jitter components that cannot be captured in a single record.

Due to the high sampling rates used in data acquisition, the Real-time Acquisition method can determine the shape of the input SDI signal. In particular, it can show actual edge transitions in a Real-time Eye diagram or in a signal waveform display. Engineers can “zoom in” on various displays to examine the signal data in different parts of the acquisition record at various scales. They can use this capability to correlate specific jitter behavior with data patterns or other signal characteristics in the SDI input signal.

Vertical cursors can be used to make manual jitter measurement on either a Real-time Eye or Equivalent-time Eye using the procedure described in section 4.3.1. Many instruments also offer Eye mask testing and other analysis tools that can help characterize both amplitude noise and jitter in SDI signals.

Jitter Measurement for Serial Digital Video Signals

► Primer

		Phase Detection/Demodulation Method		
		Equivalent-time Eye	Phase Demodulation	Real-time Acquisition
Operation		Measures individual edge variation using samples from widely separated edges captured in an Equivalent-time Eye	Demodulates baseband jitter signal from input signal using recovered clocks, band-limited by clock recovery bandwidth	Measures individual edge variation on all edges captured in one or more acquisitions
Frequency response		No frequency-related limitations	Clock recovery bandwidth affects measurement of high frequency jitter	Acquisition record size affects measurement of low frequency jitter
Dynamic range		Typically less than 1 UI	Typically greater than 1 UI	Greater than 1 UI
Sampling of baseband jitter modulation	Style	Equivalent-time	Real-time	Real-time
	Typical rates	< 1.5 MS/sec	5-20 MS/sec	Typically between 25% and 50% of data rate
Coverage		Depending on observation time, low sample density can miss contribution from intermittent jitter behaviors	Continuously monitors band-limited demodulated jitter signal (phase detector output)	Full coverage within acquisition record, no coverage in gaps between records
Signal displays		Cannot construct jitter waveform or spectrum display from histogram data	Can produce jitter waveform and spectrum displays of band-limited demodulated jitter signal	Can produce jitter waveform and spectrum displays from TIE measurements within a single acquisition record

► **Table 3.** Summary of jitter specifications.

4.3.4. Phase detection/demodulation: Summary of methods

For the three phase detection/demodulation methods described in this section, Table 3 summarizes the key characteristics that most affect peak-to-peak jitter measurement.

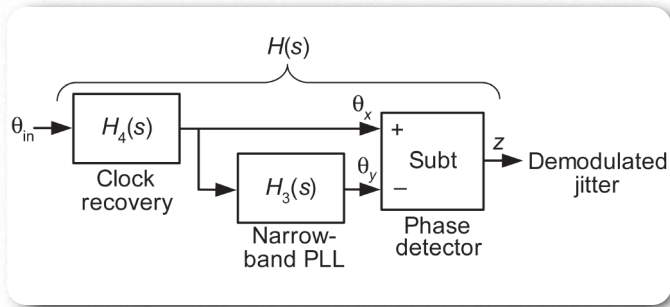

▶ **Figure 26.** Mathematical flow graph of Phase Demodulation method.

4.4. Measurement filters

Differences in the phase detection/demodulation methods lead to differences in realizing the bandpass restrictions specified for measuring timing and alignment jitter (Figure 13, Figure 14). In this section, we present a short mathematical analysis of these differences. We also describe the impact of filter accuracy on jitter measurement.

4.4.1. Filter realization

We start with an analysis for the Phase Demodulation method. As shown in Figure 22, this method uses two phase-locked loops, i.e. the wide-band clock recovery PLL and a narrow-band PLL. This makes the analysis slightly more complex.

Figure 26 is a mathematical flow graph of the phase processing corresponding to Figure 22. The phase of the input signal is designated θ_{in} , and the phases of clocks x and y are designated θ_x and θ_y , respectively. The lowpass transfer function of the clock recovery is $H_4(s)$, and the lowpass transfer function of the narrow-band PLL is $H_3(s)$. The combination of these two transfer functions realize a bandpass function $H(s)$ that satisfies the frequency restrictions for measuring timing and alignment jitter.

For this analysis, let the s-domain representation of the lowpass transfer functions of the narrow-band PLL and the clock recovery be:

$$H_3(s) = \frac{2a_3s^2 + 2a_3^2s + a_3^3}{s^3 + 2a_3s^2 + 2a_3^2s + a_3^3}, \quad H_4(s) = \frac{a_4}{s + a_4}$$

Where:

$$a_3 = 2\pi f_3 = 2\pi \cdot (0.1 \text{ MHz}), \quad a_4 = 2\pi f_4 = 2\pi \cdot (148.5 \text{ MHz}).$$

$H_3(s)$ is the transfer function for a 3rd-order narrow-band PLL and $H_4(s)$ is the transfer function for a 1st-order wide-band clock recovery process. The values selected for a_3 and a_4 will realize the bandpass specification for measuring alignment jitter on an HD-SDI signal.

The total transfer function is:

$$H(s) = H_4(s)[1 - H_3(s)] = \frac{a_4}{s + a_4} \cdot \frac{s^3}{s^3 + 2a_3s^2 + 2a_3^2s + a_3^3}$$

Jitter Measurement for Serial Digital Video Signals

► Primer

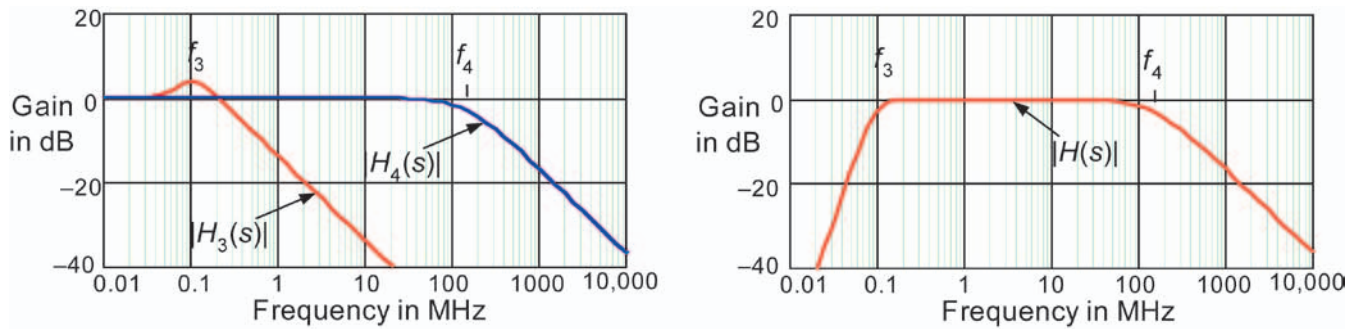

► **Figure 27.** Frequency responses of $H_3(s)$, $H_4(s)$, and $H(s)$ in Figure 26.

The frequency responses of these transfer functions are plotted in Figure 27. Note that the lowpass function $H_3(s)$, when subtracted from unity, yields the highpass function in $H(s)$. Compare the frequency response of $|H(s)|$ with the frequency response in Figure 14.

The choice of a_4 realizes the SMPTE 292M specification that f_4 be at least 1/10 of the 1.485 GHz clock rate of the HD-SDI signal. As noted in section 4.3.2, clock recovery hardware cannot achieve this loop bandwidth because SDI signals do not have sufficient edges. For an actual implementation of the Phase Demodulation method, a_4 would be a smaller value determined by the clock recovery bandwidth.

This situation does not necessarily imply that measurements made with the Phase Demodulation method will be lower than measurements made with the other methods. The jitter spectrum of many SDI signals does not contain significant energy above commonly available clock recovery bandwidths. In this case, measurements made with the Phase Demodulation method can agree closely with the measurements from other methods (Appendix A).

With a 3rd-order, narrow-band PLL, the highpass slope of $H(s)$ rises faster than the minimum 40 dB/decade specification shown in Figure 14. Instead, it realizes the 60 dB/decade highpass slope shown in Figure 13 and specified by IEEE Std. 1521 for proper rejection of wander. Using this approach, the same implementation can measure either timing or alignment jitter.

Removing $H_4(s)$ from the model in Figure 26 produces the mathematical flow graph of the phase processing for the Equivalent-time Eye method (Figure 20). To conform to IEEE Std. 1521, the narrow-band PLL in this method would need the same lowpass transfer function:

$$H_3(s) = \frac{2a_3s^2 + 2a_3^2s + a_3^3}{s^3 + 2a_3s^2 + 2a_3^2s + a_3^3}$$

This leads to a high-pass transfer function for the total transfer function $H(s)$ of:

$$H(s) = 1 - H_3(s) = \frac{s^3}{s^3 + 2a_3s^2 + 2a_3^2s + a_3^3}$$

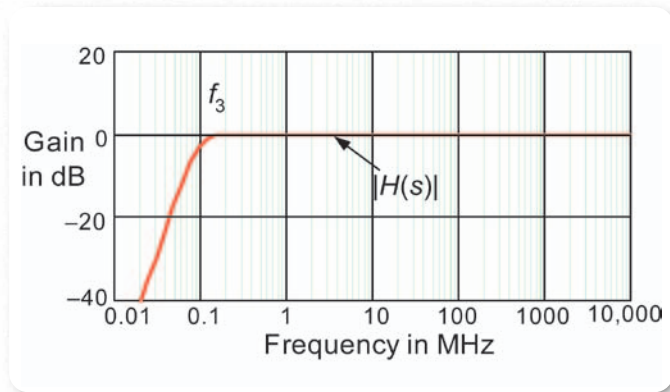

▶ **Figure 28.** Frequency response of total transfer function $H(s)$ for Equivalent-Eye Method.

The result is a total transfer function $H(s)$ that effectively has no roll-off at high frequencies, as shown in Figure 28. This response is consistent with the specification that f_4 be at least 1/10 the clock rate. If a_3 equal $2\pi \cdot (0.1 \text{ MHz})$, the response shown in the figure has a low-frequency cutoff that meets SMPTE 292M requirements for measuring alignment jitter.

In the Real-time Acquisition method, proper configuration of the measurement filter stage could realize a frequency response like Figure 28. Proper configuration of PLL-based clock recovery software could also realize this transfer function if the clock recovery algorithm could implement a 3rd-order PLL. Otherwise, additional filtering would be required to realize the appropriate highpass slope. This method could also realize the frequency response in Figure 27 with proper configuration of the filtering and clock recovery algorithms.

For all methods, setting $a_3 = 2\pi \cdot (10 \text{ Hz})$ in the narrow-band PLL produces a system transfer function that realizes the bandpass restriction for measuring timing jitter (Figure 13).

4.4.2. Filter accuracy

To correctly reject wander components in SDI signals, IEEE Std. 1521 specifies that the highpass corner of the bandpass for timing jitter measurements, f_1 , should equal $10 \text{ Hz} \pm 20\%$. The standards do not specify accuracy for f_3 and f_4 . As described in section 3.2, the standards specify minimum values for the bandpass slopes. The slopes shown in Figure 13 and Figure 14 represent the combination of minimal specifications from all relevant standards.

Using different values for the frequency cutoffs and slopes can produce different peak-to-peak jitter amplitude measurements. The amount of variation depends on the spectral characteristics of the jitter signal.

Filter accuracy has an especially strong impact on timing jitter measurement because these measurements need to reject wander components. Some video devices, e.g., MPEG decoders, can produce outputs with large wander components. Further, wander can build as a signal flows through a video system.

In these cases, differences in realizing the bandpass cutoff frequency and slope specified for timing jitter measurements can lead to significantly different values for peak-to-peak amplitude. In particular, measurements made with a bandpass that conforms to the SMPTE RP 192 specification for at least 40 dB/decade wander rejection can be much larger than measurements made with a bandpass that conforms to the IEEE Std. 1521 specification for 60 dB/decade wander rejection (see section 6.2.1).

Jitter Measurement for Serial Digital Video Signals

► Primer

4.5. Peak-to-Peak measurement

The last stage of the jitter measurement process determines the peak-to-peak jitter amplitude. While the standards specify that output jitter shall be specified and measured as a peak-to-peak quantity, they give little guidance on making the measurement (see section 3.6). Much of the variation seen in jitter measurement results arises from differences in implementing this stage in the process.

4.5.1. Peak-to-peak detection methods

The Equivalent-time Eye method and the Real-time Acquisition method measure peak-to-peak amplitude by calculating the difference between the minimum and maximum values in a collection of jitter amplitude values.

The Phase Demodulation method measures the peak-to-peak amplitude of a band-limited demodulated jitter signal (phase detector output). Earlier-generation implementations of the Phase Demodulation method use analog peak detection. Later-generation implementations digitally sample the signal from the phase detector and measure the peak-to-peak amplitude of the jitter samples.

In analog peak detection, the attack time of the peak detectors strongly affects the accuracy of the peak-to-peak amplitude measurements. Short attack times let the peak detector more accurately track rapid changes in jitter signal amplitudes. Long attack times cannot track these changes and produce lower amplitude measurements. Generally, digital implementations can more accurately measure the true peak-to-peak value.

4.5.2. Independent jitter samples and normalized measurement time

In section 3.6, we briefly described the relationship between measured peak-to-peak jitter amplitude and measurement time. In exploring this relationship further, we will use two concepts connected with sampling the jitter signal: Nyquist-rate sampling and independent samples.

To collect all the available information about a jitter signal, including the jitter waveform shape, the sampling rate must be at least the Nyquist rate. The Nyquist rate equals $2 \cdot f_{JBW}$ where f_{JBW} is the “effective” jitter signal bandwidth. In the case of the Phase Demodulation method, the effective jitter signal bandwidth is less than or equal to the loop bandwidth of the wide-band clock recovery process. To the degree that the other two methods realize the measurement

bandpass shown in Figure 28, the effective jitter signal bandwidth equals the highest jitter frequency in the input signal.

A set of samples collected at a rate greater than the Nyquist rate will have the information needed to reconstruct the jitter signal. In fact, this sample set contains redundant information about the jitter signal. Specifically, adjacent samples are not *independent* samples of the demodulated jitter signal. The larger sample set can be constructed from a smaller subset of independent samples. Adjacent samples in the full sample set have some degree of time-correlation.⁵

Any set of jitter samples collected at a rate lower than the Nyquist rate cannot represent the complete jitter signal. However, this set may be sufficient to determine several statistical properties of the phase modulation, e.g., mean, variance, and RMS. For best results, this sub-Nyquist sampling should produce a set of independent jitter samples. With a sufficient number of independent jitter samples, this set can yield acceptable estimates of statistical properties.

As we show in the following sections, both the sampling method and the number of independent jitter samples used in a peak-to-peak amplitude measurement can significantly impact the measurement result. The different jitter measurement methods collect independent jitter samples in different ways and at different rates. Thus, we cannot easily compare peak-to-peak measurements made over identical time intervals because these measurements do not involve the same number of independent jitter samples.

Instead, we will use the number of independent jitter samples as a method-independent way to describe how the duration of a peak-to-peak amplitude measurement affects the measurement result. We will call the number of independent jitter samples collected during measurement time T the *normalized measurement time*. We can then compare the actual measurement times each method requires to collect the number of independent jitter samples corresponding to a particular normalized measurement time.

⁵ In mathematical terms, the first zero in the autocorrelation function associated with the demodulated jitter signal occurs at $\pm 1/(2 \cdot f_{BW})$, where f_{BW} is the bandwidth of the signal's power spectrum. Samples separated by this time interval will be independent, i.e. will not be time-correlated. Samples spaced at less than this interval will have some degree of correlation. A sample spacing of $1/(2 \cdot f_{BW})$ corresponds to a sample rate of $2 \cdot f_{BW}$, i.e. the Nyquist rate.

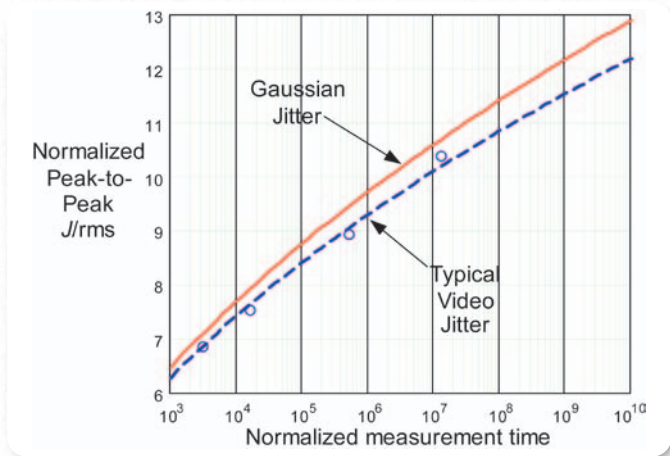

▶ **Figure 29.** Effect of normalized measurement time on measured peak-to-peak jitter amplitude (J/rms).

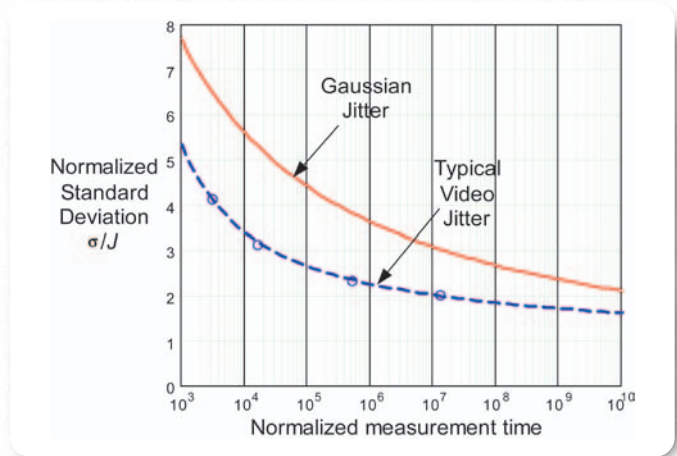

▶ **Figure 30.** Effect of normalized measurement time on the consistency (standard deviation σ) of a peak-to-peak jitter measurement.

The normalized measurement time, N , corresponding to an actual measurement time, T , is given by the equation $N = T \cdot \min(S, 2 \cdot f_{JBW})$. In this equation, S is the actual rate that the jitter measurement process collects samples of the signal jitter; f_{JBW} is the effective jitter signal bandwidth; and the function $\min(x,y)$ equals the minimum value of the two arguments.

4.5.3. Measuring the peak-to-peak amplitude of random jitter

We first consider the impact of normalized measurement time on the measured peak-to-peak amplitude of random jitter. As noted in section 2.6, random jitter is generally modeled by a Gaussian amplitude distribution. In practice, the peak-to-peak amplitude of random jitter has the “unbounded” property associated with this probability distribution, i.e. the measured peak to peak amplitude increases as the measurement time increases.

With any random process, measurement results depend on the number of independent samples used in the measurement. A more precise statement of the unbounded property would say that the measured peak-to-peak amplitude of random jitter increases as the number of independent samples of the random jitter increases. In other words, the peak-to-peak amplitude measurement increases monotonically with increased normalized measurement time.

Figure 29 shows the relationship between peak-to-peak amplitude and normalized measurement time for Gaussian random jitter (red line). The graph plots the ratio of the peak-to-peak measurement (J) to the RMS jitter amplitude as a function of normalized measurement time.

As expected, the ratio increases. Increasing the number of independent jitter samples increases the probability that the set of jitter samples will include some of the high amplitude values in the tails of the Gaussian distribution. Hence, J increases with respect to the RMS value. Since the Gaussian distribution has unbounded peak-to-peak amplitude, this ratio will continue to grow with the number of independent jitter samples.

However, using the same number of independent jitter samples in multiple measurements of peak-to-peak amplitude will not yield identical results because these measurements are sampling a random process. Different sample sets will contain amplitudes from different points in the Gaussian distribution. Thus, multiple peak-to-peak amplitude measurement will also have random variation.

The red line in Figure 30 shows this variation for Gaussian random jitter by plotting the ratio of the standard deviation in a set of peak-to-peak measurements (σ) to the average peak-to-peak measurement (J) as a function of normalized measurement time. As the number of independent jitter samples increases, this ratio decreases. The larger sample sets more fully characterize the random jitter and produce more consistent results over multiple measurements.

Typical video signals include both deterministic jitter and random jitter. The J/rms and σ/J ratios for signals containing both deterministic and random jitter will not fall on the red lines in Figure 29 and Figure 30.

Jitter Measurement for Serial Digital Video Signals

► Primer

To see why, consider two signals, A and B, where signal A contains only Gaussian-like random jitter and signal B contains both Gaussian-like random jitter and deterministic jitter. Suppose the RMS amplitude of the random jitter in signal A, (RMS_A) equals the RMS amplitude of the total jitter in signal B from both random and deterministic components (RMS_B). In this case, the random jitter in signal B ($RMS_{B_{ran}}$) must have lower RMS amplitude than the random jitter in signal A (RMS_A).

The sketch in Figure 31 illustrates the relationship between peak-to-peak jitter amplitude measurements and normalized measurement times for these two signals. In signal A (green line) random jitter determines the peak-to-peak amplitude measurement for all normalized measurement times. Consistent with Figure 29, the peak-to-peak amplitude measurement increases as the normalized measurement time increases.

For signal B (blue line), bounded deterministic jitter dominates the peak-to-peak jitter amplitude measurement for normalized measurement time below some value, N . For normalized measurement times larger than N , the unbounded Gaussian-like random jitter in B determines the value of the peak-to-peak jitter amplitude measurement. Since $RMS_{B_{ran}}$ is less than RMS_A the peak-to-peak jitter amplitude in signal B does not grow as quickly as the peak-to-peak jitter amplitude of signal A when the normalized measurement time increases.

Suppose J_A is the peak-to-peak amplitude of 1×10^4 independent samples of the jitter in signal A, and J_B is the peak-to-peak jitter amplitude of signal B over the same normalized measurement time. Since signal A has only random jitter, the ratio J_A / RMS_A will fall on the red line in Figure 29. For signal B, this same ratio will fall below the red line. The ratio J_B / RMS_B is less than the ratio J_A / RMS_A because $RMS_A = RMS_B$ and $J_B < J_A$.

So, for the same normalized measurement time, the J/rms ratio for a signal with only random jitter (signal A) will fall on the red line in Figure 29, while the J/rms ratio for a signal with both deterministic and random jitter will fall below this red line. The σ/J ratios will behave in the same way.

Appendix B describes an experiment that measures peak-to-peak jitter amplitudes for one example of a typical video signal. The blue lines in Figure 29 and Figure 30 show a plot of these measurements. The results agree with the preceding analysis that the presence of deterministic jitter

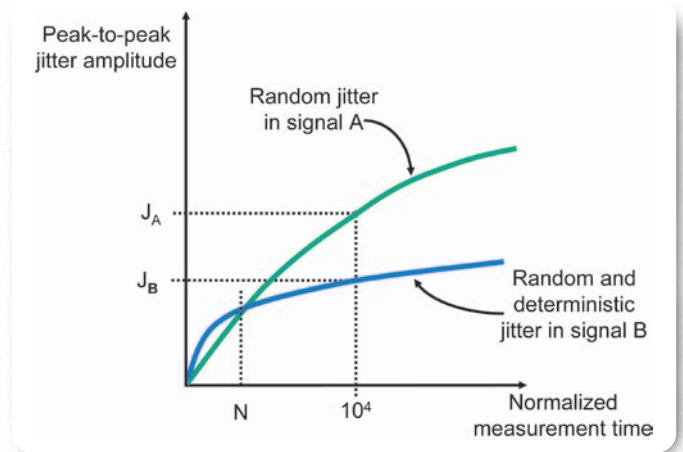

► **Figure 31.** Peak-to-peak jitter amplitude for signals A and B.

decreases the J/rms and σ/J ratios relative to the values for signals containing only random jitter.

As these plots illustrate, we cannot define a “correct” normalized measurement time based on the distribution of jitter values, either Gaussian or mixed. The measured peak-to-peak amplitude continues to increase as the normalized measurement time increases. It does not “level off” above some specific number of independent jitter samples.

Thus, to enable greater consistency in the peak-to-peak jitter amplitude measurements made by different measurement methods, the standards need to specify the number of independent jitter samples used in these measurements. For example, if each method measured the peak-to-peak amplitude of 5×10^5 independent jitter samples from a typical video signal, Figure 30 indicates that the standard deviation of the measured values would fall between 2% and 2.5%.

4.5.4. Measurement times

The different methods can collect jitter samples at different rates. As a result, peak-to-peak amplitude measurements made over the same duration can involve significantly different numbers of jitter samples. As shown in section 4.5.3, measurements made over different normalized measurement times can yield significantly different results, primarily due to the unbounded nature of random jitter.

To produce comparable results, the different jitter measurements need to measure the peak-to-peak jitter amplitude over the same normalized measurement time, i.e. the same number of independent jitter samples. This will require different actual measurement times. As a simple example, we consider the actual time each method requires to collect 1×10^6 jitter samples.

As described in section 4.3.1, the Equivalent-time Eye method collects histogram values at a rate determined by the sampling rate used in forming the Eye and the height of the histogram window. If the measurement process collects histogram values at a 5 kS/s rate, it will take 3.33 minutes to collect 1×10^6 jitter samples. At a 250 kS/s rate, this measurement time decreases to 4 seconds.

A digital implementation of the Phase Demodulation method directly samples the output of the phase detector at or above the Nyquist rate for this band-limited signal. If the measurement process samples at 10 MS/s it can collect 1×10^6 jitter samples of this band-limited demodulated jitter signal in 100 ms.

As discussed in section 4.3.3, the Real-time Acquisition method samples the jitter signal on each transition in the data signal, so the number of samples in an acquisition depends on the number of signal edges that occurred during the acquisition. If transitions occurred on 50% of the unit intervals in a 1.485 Gb/sec HD-SDI signal, then acquisitions covering 1.35 ms of this signal would acquire 1×10^6 jitter samples.

The degree of time correlation between adjacent jitter samples depends on the spacing between samples and the jitter spectral components (see section 4.5.2). Broadly speaking, widely-separated samples, e.g., like samples collected in the Equivalent-time Eye method, will have less time correlation than more closely-spaced samples, e.g., like samples collected by the Real-time Acquisition method.

Thus, peak-to-peak amplitude measurements made over the same number of jitter samples do not necessarily correspond to measurements made over the same number of independent jitter samples, i.e. over the same normalized measurement time. If low frequency jitter dominates the jitter spectrum, a larger number of closely-spaced samples may be needed to correspond to the same normalized measurement time as a set of more widely-spaced samples.

4.5.5. Dynamic range and jitter value quantization

Implementation of the three jitter measurement methods can differ in the dynamic range and quantization of the peak-to-peak amplitude measurement. In particular, some implementations may measure peak-to-peak amplitude greater than 1 UI, while others may measure only peak-to-peak jitter amplitudes up to 1 UI. If the two implementations capture peak-to-peak amplitude measurements in digital words with the same number of bits, values in an implementation with a dynamic range greater than 1 UI will have larger quantization steps than values in an implementation with a 1 UI dynamic range.

Jitter Measurement for Serial Digital Video Signals

► Primer

4.6. Jitter noise floor

Every implementation of any jitter measurement method has internal distortions, noise, and variations. These can arise from unavoidable physical properties or from engineering choices made when designing and implementing a jitter measurement process. While careful design can reduce the impact of these inherent behaviors, it cannot eliminate them completely. They impose a lower bound on jitter amplitude measurements, called the jitter *noise floor*.

Any step in the measurement process can contribute to the jitter noise floor. Primary contributors include:

- *Timebase jitter*: Various processes, e.g., sampling and clock recovery, require a stable timing reference. Many implementations use crystal or dielectric resonator oscillators to create a timing reference signal. Phase noise or other distortions in these oscillators contribute to the jitter noise floor. Silicon oscillators can contribute significant timebase jitter to the jitter noise floor.
- *Clock recovery jitter*: Distortions and noise in the hardware-based clock recovery process can also contribute to the jitter noise floor. Phase noise can contribute random jitter and long strings of identical bits can contribute deterministic, data-dependent jitter. The peak-to-peak amplitude of this data-dependent jitter is proportional to the clock recovery bandwidth. In Appendix C, we show that clock recovery bandwidths large enough to realize SMPTE measurement bandpass specifications introduce significant data-dependent jitter.
- *Equalizer jitter*: Hardware-based equalization processes can also contribute random and deterministic jitter components to the jitter noise floor. This includes deterministic data-dependent ISI due to imperfect equalization and duty-cycle dependent jitter from non-optimal threshold detection (section 4.1).

The frequency-dependent gain used in equalization (see Figure 4 in section 2.7) can also introduce jitter. This gain can increase amplitude noise present in the pre-equalized signal. In the transition detection stage, amplitude noise near the decision threshold can cause noticeable phase noise (jitter) in the detected signal edges. This AM-to-PM effect contributes high frequency jitter to the noise floor.

- *Trigger jitter*: If a jitter measurement process collects samples from acquisitions taken over multiple triggers, variations in this triggering process can introduce variations in the timing of the sampling process. These timing variations can contribute to the jitter noise floor.

Method	Key Characteristics
Equivalent-time Eye	<ul style="list-style-type: none"> ► Measures peak-to-peak jitter amplitude using a histogram of jitter values collected from equivalent-time samples of an SDI signal. ► Can measure any jitter frequencies within the SMPTE-specified bandpass restrictions. ► Dynamic range equals 1 UI in typical implementations, though an alternative version can measure peak-to-peak jitter amplitudes greater than 1 UI. ► Requires long measurement times to collect a large number of independent jitter samples.
Phase Demodulation	<ul style="list-style-type: none"> ► Measures peak-to-peak jitter amplitude by continuously sampling a band-limited demodulated jitter signal formed by detecting phase differences in two clock signals recovered from the SDI signal ► Typically has an equalization stage for measuring jitter across long cables, which can increase jitter noise floor. ► Can measure any jitter frequencies within the SMPTE-specified bandpass restrictions up to the loop bandwidth of the clock recovery circuit, where maximum loop bandwidths fall well below 1/10 the data clock rate. ► Dynamic range greater than 1 UI in typical implementations. ► Can collect a large number of independent jitter samples over a short measurement time. ► Can display a jitter waveform and jitter spectrum of the phase detector output, i.e. of a band-limited demodulated jitter signal. ► Can supply a continuous, band-limited demodulated jitter signal output from the phase detector.
Real-time Acquisition	<ul style="list-style-type: none"> ► Measures peak-to-peak jitter amplitude by computing time interval errors for each signal transition in one or more fixed-size records acquired by sampling an SDI signal in real-time. ► Can measure any jitter frequencies within the SMPTE-specified bandpass restrictions, requiring multiple acquisitions to measure down to the low-frequency limit. ► Can measure peak-to-peak jitter amplitudes greater than 1 UI. ► Can collect a large number of independent jitter samples over a short measurement time, may require multiple acquisitions to achieve normalized measurement times. ► Can generate a jitter waveform and jitter spectrum from TIE measurements. ► Can correlate jitter to signal data.

► **Table 4.** Comparison of jitter measurement methods.

4.7. Comparing jitter measurement methods

Table 4 summarizes the key characteristics of the different jitter measurement methods.

Depending on the characteristics of the jitter in an SDI signal, differences among the described methods can produce different peak-to-peak jitter amplitude measurements. The following examples illustrate several factors to consider when comparing jitter measurements made with these methods.

Comparing jitter measurements: sinusoidal jitter

Suppose an SDI signal contains random jitter with very low RMS amplitude and 1 MHz sinusoidal jitter with peak-to-peak amplitude less than 1 UI. The different methods will measure similar peak-to-peak jitter amplitude for this signal. Some variation may occur due to differences in the quantization steps used in the measurement, or in the jitter noise floor.

Jitter Measurement for Serial Digital Video Signals

► Primer

Comparing jitter measurements: high amplitude jitter

Now consider the same SDI signal, but with peak-to-peak amplitude greater than 1 UI. Typical implementations of the Phase Demodulation and the Real-time Acquisition method will detect this high amplitude jitter and will measure a similar value. Typical implementations of the Equivalent-time Eye method (Figure 20) cannot detect jitter amplitudes greater than 1 UI.

Comparing jitter measurements: high frequency jitter

For this comparison, suppose the sinusoidal jitter in the SDI signal is now 25 MHz sinusoidal jitter with peak-to-peak amplitude less than 1 UI. Typical implementations of the Equivalent-time Eye and Real-time Acquisition method can measure the peak-to-peak jitter amplitude for this signal. Implementations of the Equivalent-time Eye method may have a higher jitter noise floor, including trigger jitter. Hence, they may produce slightly higher values.

Typical implementations of the Phase Demodulation method have clock recovery bandwidths below 25 MHz. The peak-to-peak amplitude measurement will not include the contribution from this high frequency jitter and will produce a smaller peak-to-peak amplitude measurement.

Comparing jitter measurements: low frequency jitter

Next consider an SDI signal containing 10 Hz sinusoidal jitter with peak-to-peak amplitude less than 1 UI. The three methods can measure similar peak-to-peak jitter amplitude for this signal as long as they correctly implement the high-pass characteristics of the specified bandpass for timing jitter measurements. Since a single acquisition in the Real-time Acquisition method will capture only a segment of this variation, this method will need to acquire TIE measurements over multiple acquisitions.

Comparing jitter measurements: wander

Now suppose an SDI signal does not contain any deterministic jitter above 10 Hz, but does have a high amplitude wander component, i.e. a timing variation at a frequency below 10 Hz. This wander component can impact peak-to-peak amplitude methods made with any method. Suppose one implementation (any method) realizes a bandpass filter with a 40 dB/decade attenuation of frequencies below 10 Hz, while another implementation (any method) realizes the 60 dB/decade slope specified in IEEE Std. 1521. The first implementation will not reject the high amplitude wander component as well as the second implementation and will produce higher peak-to-peak amplitude measurements (see section 6.2.1).

Comparing jitter measurements: isolated jitter spikes

Instead of sinusoidal jitter, suppose that the deterministic jitter in the SDI signal consists of alternating jitter spikes where these spikes are 300 μ s in width, have amplitudes slightly above 0.1 UI and are separated by 32 ms.

As noted in section 3.6, because the SMPTE standards do not specify a measurement time, it is not clear whether the “correct” peak-to-peak amplitude measurement for this jitter should include both jitter spikes. For this example, we will interpret the standards to mean that the peak-to-peak jitter amplitude measured in this situation should be near 0.2 UI.

An implementation of the Phase Demodulation method that measured the peak-to-peak jitter amplitude over a time interval greater than 64 ms would produce a result near 0.2 UI.

With the Equivalent-time Eye method, measurements made with histograms collected and reset over short observation times may not contain samples from both peaks, which would produce a peak-to-peak amplitude value below 0.2 UI. Collecting more samples over longer observation times will eventually yield a histogram that contains samples from both jitter peaks, which would yield a result near 0.2 UI.

At current acquisition record sizes, an implementation of the Real-time Acquisition method cannot capture both jitter peaks in a single acquisition. A sufficient number of multiple acquisitions will likely contain samples from both jitter peaks and would yield a result near 0.2 UI. Measurements made over a small number of acquisitions may not contain samples from both peaks, which would produce a lower peak-to-peak amplitude value. The actual time needed to acquire and process a sufficient number of acquisitions depends on the combined durations of the individual acquisitions and the processing gaps between acquisitions.

Comparing jitter measurements: intersymbol interference due to cable attenuation

Suppose that:

- (1) The output of an SDI signal source is almost jitter-free;
- (2) This output is routed through long cables and several pieces of non-reclocking video equipment to an SDI receiver; and
- (3) We want to measure the jitter in the signal at the receiver input.

SDI receivers have cable equalizers that compensate for cable attenuation effects. To assess signal jitter that will affect signal decoding, the measurement process should exclude the data-dependent jitter due to ISI from cable attenuation. They can do this by implementing an equalization process as shown in Figure 16, or by using signal processing algorithms to separate and remove the data-dependent jitter component. Measurement processes that do not exclude this jitter will produce larger peak-to-peak amplitude measurements.

Comparing jitter measurements: jitter measurement over a short cable

Now suppose we use the same measurement processes to directly measure the output of the SDI signal source in the previous example over a short cable. Since, by supposition, the source output is nearly jitter-free, the jitter noise floor of the measurement process will determine the result of a peak-to-peak jitter amplitude measurement. Processes with a hardware-based equalization stage may produce a larger result due to contributions that the cable equalizer makes to the jitter noise floor.

Comparing jitter measurements: random jitter

All SDI signals contain some amount of random jitter, and random jitter is a primary contributor to variation in jitter measurements. Sections 4.5.2 to 4.5.4 describe several key considerations that influence peak-to-peak amplitude measurements of this essentially unbounded jitter component. In particular:

- The measured peak-to-peak jitter amplitude depends on the number of independent jitter samples used in the measurement.
- Peak-to-peak jitter amplitude measurements made over the same number of independent jitter samples will produce consistent results. Using larger normalized measurement times, i.e. more independent jitter samples, will lead to lower variation in measurement results.
- The different measurement methods collect different numbers of jitter samples over equal observations times.
- Depending on the spacing of the jitter samples and the spectral components in the jitter, measurements made of the same number of jitter samples do not necessarily correspond to the measurements over the same normalized measurement time, i.e. the same number of independent jitter samples.

With observation times that appropriately account for these considerations, any of the methods described in this guide can measure peak-to-peak jitter amplitudes over similar normalized measurement times and produce consistent and comparable results. Without considering these factors, the random jitter in SDI signals can lead to significantly different values for peak-to-peak jitter amplitude measurements.

5.0 Data Error Rates and Jitter Measurements

In section 4.0 we showed how differences in measurement processes and technology can lead to differences in peak-to-peak jitter amplitude measurements. Measurements made by two different methods on the same SDI signal can differ substantially. In fact, measurements made on the same SDI signal by different implementations of the same jitter measurement method can vary significantly.

Each method has strengths and limitations. The comparisons in section 4.7 showed that no one jitter measurement method can fully capture the wide variation in jitter characteristics. Further, because of random jitter, the measured peak-to-peak jitter amplitude depends on measurement time, or more accurately, the number of independent jitter samples used to determine the peak-to-peak value.

As a result, we cannot determine the jitter in a video system and its impact on system operation by making a single peak-to-peak amplitude measurement with one jitter measurement method. Engineers may need to use a combination of jitter measurement methods to fully characterize jitter. In fact, the variation in measurements made with different methods can offer useful information on jitter characteristics. We will discuss this topic further in section 7.0.

Because of the relationship between random jitter and data error rates, engineers also need to consider the number of independent jitter samples used in measuring peak-to-peak jitter amplitude. In this section, we show that measurements made over a small number of independent samples will not assess the potential for infrequent data errors due to high-amplitude random jitter.

5.1. Random jitter and BER

As an example, consider two SDI signal sources whose outputs contain Gaussian, spectrally flat, random jitter. Suppose that the jitter in the output from Source A has RMS amplitude of 0.012 UI, while the jitter in Source B's output has higher RMS amplitude of 0.020 UI. The output from either source can appear at the input of an SDI receiver that can tolerate alignment jitter up to a peak-to-peak amplitude value of 0.4 UI. Routing equipment between the sources and this receiver adds approximately 0.2 UI peak-to-peak of additional alignment jitter.

From Figure 29, we see that 1×10^3 independent samples of the random jitter in Source A's output would have a peak-to-peak amplitude of approximately $J = 6.5 \cdot rms = 6.5 \cdot 0.012 = 0.08$ UI, while the peak-to-peak amplitude of

the same number of samples from Source B's output would equal approximately 0.13 UI. With the additional alignment jitter from routing equipment, the alignment jitter in the signal from Source A has peak-to-peak amplitude of 0.28 UI at the receiver's input. The alignment jitter in the signal from Source B has peak-to-peak amplitude of 0.33 UI at the receiver's input. So, for signals from either SDI source, the signal jitter at the receiver's input will not exceed 0.4 UI at a rate greater than 1 in 10^3 bits, i.e. the BER for this system lies below 1×10^{-3} .

The situation changes for a larger number of samples. Over 1×10^{10} samples, the random jitter in Source B's output has a peak-to-peak amplitude of $J = 13 \cdot rms = 13 \cdot 0.020 = 0.26$ UI, while Source A's output has a peak-to-peak amplitude near 0.16 UI. With the additional alignment jitter from routing equipment, the alignment jitter in the signal from Source B now has peak-to-peak amplitude of 0.46 UI at the receiver's input. The alignment jitter in the signal from Source A has peak-to-peak amplitude of 0.36 UI at the receiver's input. Over 10^{10} bits, the SDI receiver can still tolerate the jitter in signals from Source A since the peak-to-peak amplitude falls below 0.4 UI. Signals from Source B will produce bit errors because the peak-to-peak amplitude lies above the receiver's alignment jitter tolerance. Due to the random jitter in Source B, the video system cannot sustain a BER of 1×10^{-10} .

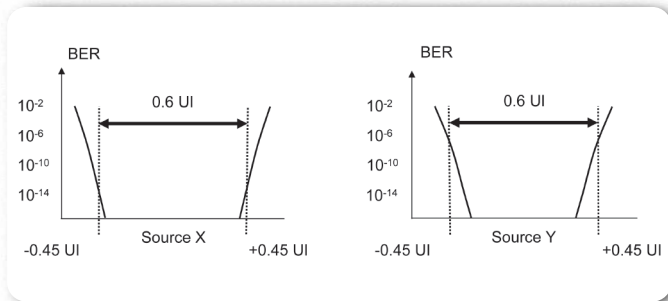

▶ **Figure 32.** Bathtub curves for sources with random jitter at different RMS amplitude.

Bathtub curves of SDI signal source outputs can help determine the potential BER for video systems using these sources. Figure 32 illustrates this technique using sketches of Bathtub curves of the output signal from two SDI sources, X and Y. Both output signals contain only Gaussian-like random jitter. The random jitter in Source Y has the larger RMS amplitude.

In a video system with the SDI receiver and routing equipment described above, transitions in the source output that occur within ± 0.3 UI of the Eye opening's center point can cause a bit error in the receiver. The Bathtub curve for Source X shows that less than 1 in 10^{12} transitions would enter this region in this source's output signal. In the output signal from Source Y, transitions would enter the region at a rate of more than 1 in 10^7 transitions. In other words, with Source X, the system BER lies below 1×10^{-12} , while with Source Y the BER falls between 1×10^{-6} and 1×10^{-7} .

For an HD-SDI signal, 10^{12} bits corresponds to 11.2 minutes of video. So, a BER below 1×10^{-12} corresponds to a data error rate of less than 1 error in 11 minutes. On the other hand, 10^7 bits corresponds to 6.73 ms of video. A BER above 1×10^{-7} corresponds to a data error rate of more than 1 error per video frame.

5.2. Jitter measurement and standards compliance

For sources A and B described in the section 5.1, a peak-to-peak amplitude measurement of alignment jitter made over 1×10^3 independent jitter samples would indicate that both sources comply with SMPTE specifications on alignment jitter, i.e. less than 0.2 UI. A peak-to-peak amplitude measurement of alignment jitter made over 1×10^7 independent jitter samples would also show that Source A is in compliance, but would indicate that Source B is out of compliance. Thus, differences in the number of independent jitter samples in a measurement can lead to different assessments about compliance.

Generally, these differences arise from the random jitter in the source output. As noted in section 2.6, deterministic jitter has bounded peak-to-peak amplitude. If the peak-to-peak amplitude of deterministic alignment jitter in a source output lies below 0.2 UI, increasing the normalized measurement times will not produce peak-to-peak amplitude measurements above 0.2 UI for this deterministic jitter component.

Random jitter does not have this bounded property. Even if the random alignment jitter in a source output has a low RMS amplitude, jitter amplitudes above 0.2 UI can occasionally occur. Longer normalized measurement times will detect these higher amplitude variations and yield a peak-to-peak amplitude measurement above 0.2 UI.

The SMPTE standards do not specify how long the peak-to-peak jitter amplitude in a source output must remain below the specified limits, which creates ambiguity in assessing source compliance. For example, consider the following statements about the output signal from Source Y in Figure 32.

- ▶ Source Y *would comply* with a specification that said the peak-to-peak alignment jitter amplitude in the output signal must not exceed 0.2 UI except for 1 in 10^6 transitions.
- ▶ Source Y *would not comply* with a specification that said the peak-to-peak alignment jitter amplitude in the output signal must not exceed 0.2 UI except for 1 in 10^{10} transitions.

In this example, Source Y complies or does not comply with the SMPTE-specified limits on the peak-to-peak alignment jitter amplitude, depending on the number of transitions considered in making the assessment. Since the standards do not specify this value, Source Y's compliance cannot be unambiguously determined.

Jitter Measurement for Serial Digital Video Signals

► Primer

Bathtub curves can be used to assess the relative compliance of two sources. For the sources illustrated in Figure 32, the Bathtub curves indicate that Source X will stay in compliance with SMPTE specifications on peak-to-peak alignment jitter amplitude longer than Source Y.

However, without a specification on the number of transitions that can exceed the specified limits, neither source unambiguously complies with the standards. In particular, the Bathtub curve indicates that Source X would not comply with the specification if the peak-to-peak alignment jitter amplitude in the output signal could not exceed 0.2 UI except for 1 in 10^{14} transitions.

The Japanese video standard ARIB RT-B24 does give a specification on data error rates in video systems. It specifies that a video system should have an average data error rate of less than one error every 3 minutes. In 3 minutes, an HD-SDI signal typically has more than 1×10^{11} transitions. So, the ARIB specification corresponds to a BER below 1×10^{-11} .

Suppose that the two sources shown in Figure 32 were HD-SDI sources and were used in video systems that would have bit errors if the peak-to-peak jitter amplitude in a source output exceeded 0.2 UI. Then, systems that used Source X would comply with the ARIB standard, but systems that used Source Y would not comply.

5.3. BER and jitter measurement time

Fortunately, verifying that signal sources can meet low BER targets does not require making peak-to-peak amplitude measurements over a very large number of independent jitter samples. Various methods exist that use fewer independent jitter samples collected over shorter observation times, to estimate the peak-to-peak jitter amplitude over a larger number of independent jitter samples.

Figure 33 illustrates one procedure for using peak-to-peak amplitude measurements made over smaller normalized measurement times to estimate the results of measurements made with a large number of independent jitter samples. This Mathcad plot shows the relationship between the value of a peak-to-peak amplitude measurement and a BER associated with the number of independent jitter samples used in making the measurement.

The blue diamonds on the graph show this relationship for the measurements made in Appendix B. These measurements were made on an HD SDI source output containing a random jitter component with an RMS amplitude value of about 18.8 ps and a negligible deterministic jitter compo-

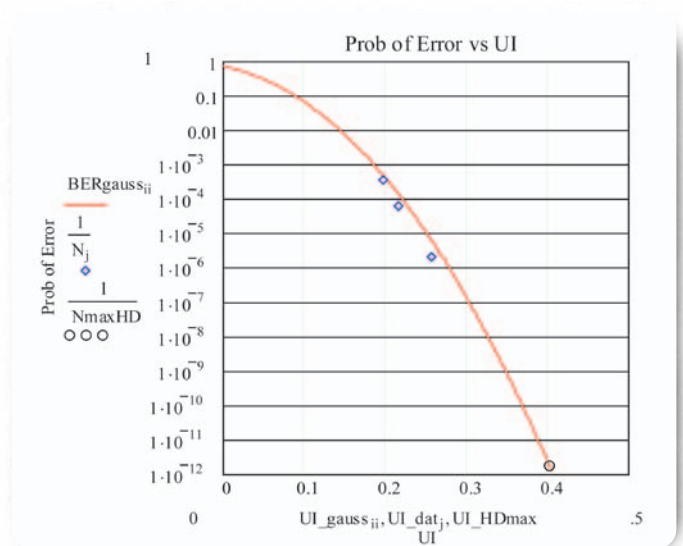

► **Figure 33.** BER vs. peak-to-peak jitter amplitude for a typical video signal.

nent. The measured source output in this experiment had peak-to-peak jitter amplitude equal to 0.19 UI when measured over 3×10^3 independent jitter samples. If peak-to-peak jitter amplitude of 0.19 UI in a source output does not cause bit errors in a system, this source can ensure that bit errors occur at a rate of less than 1 error in 3×10^3 bits. This corresponds to a BER of $1 / 3 \times 10^3 = 3.3 \times 10^{-4}$ as shown on the plot.

For 1.6×10^4 independent jitter samples, the measured peak-to-peak amplitude equaled 0.21 UI. If jitter in the source output can reach peak-to-peak amplitude of 0.21 UI before a bit error occurs in a system, then this source can ensure a BER of $6.25 \times 10^{-5} = 1 / 1.6 \times 10^4$ as shown.

The red line in the plot shows a theoretical curve for Gaussian random jitter that falls slightly to the right of the measured peak-to-peak jitter amplitude values taken over different values of N independent jitter samples. This curve is essentially the same as the red line in Figure 29. The BER values on the vertical axis in Figure 33 correspond to the normalized measurement times on the horizontal axis in Figure 29. The horizontal axis in Figure 33 shows peak-to-peak amplitude measurements, not the J/rms ratio. Hence, the red line in Figure 33 shows the theoretical peak-to-peak jitter amplitude of Gaussian random jitter with a particular RMS amplitude of 0.028 UI (18.8 ps).

We can use the curve in Figure 33 to make a “worst-case” estimate of the peak-to-peak jitter amplitude in a source that has random jitter in the output signal with RMS amplitude of 0.028 UI. In particular, the curve shows that over

almost 10^{12} jitter samples, the worst-case peak-to-peak jitter amplitude in this signal equals 0.4 UI (black circle on diagram). Suppose a video system that had to meet the ARIB specification included this source. This system would have to tolerate peak-to-peak jitter amplitude of around 0.4 UI in a source output. Otherwise, the random jitter in the output from this source, with this particular RMS amplitude of 0.028 UI, will create a BER above the ARIB specification.

This procedure estimates BER values based on the behavior of random jitter. Due to omnipresent thermal noise, all SDI signals will have some level of random jitter, and this “unbounded” random jitter will determine the peak-to-peak amplitude value measured over a large number of independent jitter samples, i.e. a long normalized measurement time.

For smaller normalized measurement times, bounded deterministic jitter can determine the peak-to-peak amplitude. The normalized measurement time at which the random component will begin to dominate the total peak-to-peak amplitude value depends on the ratio of the RMS amplitude of the random jitter to the peak-to-peak amplitude of the deterministic jitter.

So, the procedure described in this section must include an initial set of measurements to determine the maximum peak-to-peak amplitude of any deterministic jitter in the signal. This establishes a lower bound on the number of independent jitter samples used for the measurements in the plot.

5.4. Jitter budget

As noted in section 3.5, the SMPTE standards specify the allowed jitter in a source output. However, jitter in the source output does not completely determine the data error rate in a video system.

In the example used in section 5.1, Source B generated bit errors because the video equipment between Source B and the SDI receiver added 0.2 UI of jitter. This pushed the signal jitter above the receiver’s jitter input tolerance.

Now suppose that the video equipment between Source B and the receiver only added 0.1 UI of jitter. This system would have a BER well below 1×10^{-10} . Thus, measured peak-to-peak jitter amplitude values above 0.2 UI in a source output do not necessarily correlate with high data error rates.

As a second example, suppose a facility adopted the ARIB requirements for acceptable data error rates. The engineering staff confirmed that Source A has less than 0.2 UI and they included this source in the system. The SDI receivers in the system all have a jitter input tolerance around 0.4 UI and the routing equipment does not add more than 0.15 UI jitter.

Now suppose a routine equipment replacement introduces a receiver with a jitter input tolerance of 0.35 UI and new routing equipment that adds more than 0.15 UI of jitter. On average, the peak-to-peak jitter amplitude in Source A’s output will exceed 0.16 UI once in every 10^{10} bits. This amplitude will generate data errors in the new system and the system BER will fall below the ARIB specification. Thus, measured peak-to-peak jitter amplitude values below 0.2 UI in a source output do not ensure low data error rates in all systems.

Currently, the video standards impose a conservative requirement on signal sources to ensure their output signals have a wide-open Eye most of the time. Since the source output does not completely determine the data error rate in a video system, the current situation presents SDI source designers with a substantial challenge. Without specifications or guidance on acceptable data error rates, minimal jitter input tolerance, and maximum jitter transfer, they cannot determine how long the jitter in the source output must remain below the specified thresholds.

SDI source designers need information on the *jitter budget* for a video system, i.e. the data error rate and the jitter performance each element must achieve to ensure acceptable operation. This information will determine how long jitter in the source output must remain below specified thresholds.

With an understanding of jitter budgets, the properties of signal jitter, the jitter performance of the equipment installed in video systems, and the characteristics of various jitter measurement methods, engineers can more effectively and efficiently deploy jitter measurement instruments in equipment design, system integration, equipment qualification and system maintenance.

Jitter Measurement for Serial Digital Video Signals

► Primer

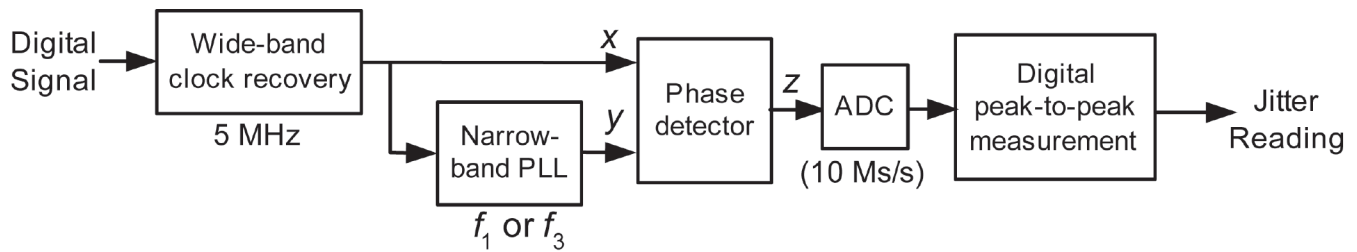

► **Figure 34.** Phase Demodulation method in WFM700M.

6.0 Jitter Measurement with Tektronix Instruments

Tektronix offers several video and general-purpose instruments that make automated peak-to-peak jitter amplitude measurements. In this section, we use these products to illustrate particular implementations of each of the jitter measurement methods examined in this guide.

6.1. Jitter measurement with the Tektronix WFM700M

The Tektronix WFM700M Waveform Monitor uses the Phase Demodulation method to automatically measure peak-to-peak video jitter on HD and SD-SDI signals (Figure 34). The instrument uses a commercially-available SDI receiver IC with a cable equalizer. Clock x in Figure 34 is the clock output from the receiver IC. Thus, the WFM700M measures the jitter in an equalized SDI signal that corresponds closely to the signal that SDI receivers decode.

The phase detector generates a demodulated jitter signal in real-time. The instrument can display this jitter waveform and can route the signal to an output BNC. Connecting this output to a spectrum analyzer will generate a jitter spectrum display.

The wide-band clock recovery circuit used in the SDI receiver IC has a 5 MHz bandwidth, which establishes the high frequency cutoff of the measurement bandpass filter (f_4). A measurement filter after the phase detector supplements the high-pass filtering of the narrow-band PLL bandwidth. This filter establishes the low frequency cutoffs for the bandpass filters used for measuring timing and alignment jitter either (f_1 or f_3). The bandpass slopes comply with SMPTE recommendations and the wander rejection of the timing jitter filter complies with IEEE Std. 1521.

The ADC samples the demodulated jitter signal at a rate greater than the 10 MS/s Nyquist rate for the 5 MHz bandwidth of the demodulated jitter signal. The final stage measures the peak-to-peak value of these samples over $T = 500$ ms. This measurement duration corresponds to a normalized measurement time of $N = 5 \times 10^6$ independent samples.

6.2. Jitter measurement with other Tektronix video instruments

The WFM601M Waveform Monitor also uses the Phase Demodulation method with a 5 MHz clock recovery bandwidth to measure peak-to-peak jitter amplitude in equalized SD-SDI signals. The peak-to-peak measurement stage uses analog peak detection.

The VM700T Option 1S can measure jitter amplitude in equalized SD-SDI signals with either the Phase Demodulation method or the Equivalent-time Eye method. The clock recovery bandwidth for the Phase Demodulation method is approximately 7 MHz, larger than the WFM601M or WFM700M. Like the WFM601M, the peak-to-peak measurement stage uses analog peak detection. The Equivalent-time Eye method samples the input SD-SDI signal at approximately 3 MS/s. The VM700T can also measure wander in SD-SDI signals, and both wander and jitter in analog video signals.

Tektronix developed and introduced the WFM601M, VM700 Option 1S, and WFM700M at different times. Consequently, they have different implementations of the jitter measurement methods and can give different results when measuring jitter on the same video signal. We can use the information in the preceding sections to understand these differences.

6.2.1. Wander rejection

Tektronix launched the WFM601M before IEEE Std. 1521 was proposed. Hence, the implemented measurement filter has a 40 dB/decade high-pass response at 10Hz rather than the 60 dB/decade slope shown in Figure 13.

Tektronix developed the VM700 Option 1S before IEEE drafted Std. 1521, but the design anticipated this specification. Hence, the Phase Demodulation method used in the VM700 Option 1S complies with the 60 dB/decade slope required for wander rejection. The Equivalent-time Eye method implemented in the VM700T has the 40 dB/decade slope commonly used in forming equivalent-time Eye pattern, which does not comply with IEEE Std. 1521 specification for wander rejection.

To determine how differences in wander rejection affect SDI jitter measurement, measurements were made of the peak-to-peak jitter amplitude in the SD-SDI output of an MPEG decoder with the WFM700M, WFM601M and the Phase Demodulation method implemented in VM700 Option 1S. The MPEG decoder received its input signal from a QPSK satellite receiver tuned to a signal from a satellite DTV provider. Due to MPEG data buffering, the SD-SDI output commonly has a significant wander component.

Measurements made with the Wander application on the VM700T confirmed a frequency-offset variation in steps of 1.75 ppm with a peak frequency-offset of 2.5 ppm. The SDI output from the MPEG decoder complies with the 2.8 ppm frequency-offset limit for a studio-quality video reference but exceeds the 0.028 ppm/sec frequency drift-rate limit by 20 to 30 times. However, this SDI output would not normally appear as a studio reference and consumer video equipment can track this wander.

We then measured the jitter on the SDI output of the MPEG decoder. The WFM601M measured 1.6 UI of timing jitter compared to the 0.4 UI measured with the Phase Demodulation method on the VM700 Option 1S and WFM700M. With the frequency offset removed, the measured jitter drops to around 0.3 UI for all instruments.

Thus, implementations of jitter measurement methods that realize only a 40 dB/decade slope in the high-pass characteristics of the timing jitter filter (e.g., the WFM601M) can overestimate the peak-to-peak jitter amplitude. In the presence of a wander component commonly seen in the SDI output from an MPEG decoder, the WFM601M overestimated jitter amplitude by more than 500% (1.6 UI compared to 0.3 UI). Implementations with a 60 dB/decade slope better reject the wander component. In this experiment, wander that passed through the measurement filters implemented in the WFM700M and VM700T Option 1S contributed only about 33% to the timing jitter measurement (0.4 UI compared to 0.3 UI).

6.2.2. Measurement of random jitter

These products use different technology in making the peak-to-peak measurements and consequently have different measurement times. As we have shown, measurement time has a large effect on peak-to-peak jitter values for SDI signals with significant random jitter (Figure 29).

The Phase Demodulation method implemented in the WFM700M has the longest detection time (500 ms) with a digital, highly accurate peak-to-peak detector. Implementations of the Phase Demodulation method in the VM700 Option 1S and WFM601M use analog peak detection technology with an effective measurement time of approximately 2.5 ms.

On an SDI signal with only random jitter, experiments have verified that the analog-peak detection used in the WFM601M and VM700T Option 1S led to peak-to-peak amplitude measurements approximately 30% lower than the digital peak detection in the WFM700M.

The peak-to-peak amplitude measurements on the WFM601M and VM700T Option 1S were lower than the WFM700M because they measured the random jitter over a short duration. They are all valid measurements of this peak-to-peak amplitude since the standards do not specify a measurement time or the number of independent jitter samples to use in the measurement.

Although all these instruments validly measure the peak-to-peak jitter amplitude, the digital implementation in the WFM700M does offer an improved measurement compared to the analog-based implementations in the earlier-generation instruments. The longer measurement time available with the digital implementation can more consistently measure contributions from infrequent, high-amplitude random jitter that can produce data errors in video systems.

Jitter Measurement for Serial Digital Video Signals

► Primer

6.2.3. Measurement of deterministic jitter

Some SDI test signal generators can introduce sinusoidal jitter at different amplitudes and frequencies into their SDI outputs. These three video instruments will measure similar peak-to-peak amplitudes for this sinusoidal jitter, although variations can occur due to differences in frequency response, the amount of random jitter in the signal, and differences in jitter noise floor compensation.

Larger differences can arise with rapidly varying or “spike-like” deterministic jitter. If the deterministic jitter has rapid variations, the WFM601M and VM700T Option 1S may give lower results than the WFM700M because the attack time in the analog implementation of the phase detector may not fully track these variations. With narrow, separated jitter peaks or intermittent jitter, the Equivalent-time Eye method in the VM700T may give lower results than either the WFM700M or the WFM601M because the equivalent-time sampling used in forming the Eye may not sample the true peaks during the measurement period.

Differences can also arise if a signal has high-frequency deterministic jitter. A peak-to-peak jitter amplitude measurement made with the Equivalent-time Eye method can include contributions from any spectral component within the measurement bandpass. Measurements made with the Phase Demodulation method do not include contributions from spectral components beyond the demodulated jitter signal's bandwidth.

As a result:

- A peak-to-peak amplitude measurement made with the Equivalent-time Eye method on the VM700T may have a larger value than measurements made on the same signal with the WFM601M and WFM700M if a signal's jitter spectrum contains spectral components above 5 MHz.
- A peak-to-peak amplitude measurement made with the Equivalent-time Eye method on the VM700T Option 1S may have a larger value than a measurement made on the same signal and instrument with the Phase Demodulation method if a signal's jitter spectrum contains spectral components above 7 MHz.

6.3. Jitter measurement with Tektronix real-time oscilloscopes

Tektronix real-time oscilloscopes implement versions of the Real-time Acquisition method in application software for jitter measurement. The TDSRT-EYE® and TDSJIT3 software measure peak-to-peak jitter amplitude from TIE measurements based on a recovered reference clock.

Peak-to-peak jitter amplitude measurements made with these software applications can vary from measurements made with the video-specific instruments due to differences in several areas.

- The video-specific products have built-in support for the SMPTE-specified measurement bandpass restrictions. Realizing these measurement filters in the TDSRT-EYE and TDSJIT3 application requires proper configuration of clock recovery and filtering algorithms. Differences in measurement filtering can generate different measurement results.
- Accurately measuring jitter frequencies down to 10 Hz or widely-separated jitter peaks requires an adequate number of multiple acquisitions on a real-time oscilloscope. Using a smaller number of acquisitions in these measurements could lead to differences in measurement results.
- TDSRT-EYE and TDSJIT3 software can measure jitter frequencies up to and beyond the SMPTE specification of 1/10 clock rate. Depending on the actual high frequency jitter components in the signal, they can produce higher peak-to-peak jitter amplitude measurements compared to measurements made with the Phase Demodulation method in the video-specific instruments.
- Both these software applications can compute jitter statistics over a specified population of TIE measurements. With appropriately-sized populations of TIE measurements that account for the effect of random jitter, these applications can produce peak-to-peak amplitude measurements similar to the video-specific instruments. Differing numbers of independent jitter samples can lead to different measurement results.
- The video-specific instruments use hardware-based equalization and clock recovery and have a higher jitter noise floor. This can produce noticeable differences in jitter measurement made over short cables. For measurements made over long cables, the equalization stage in the video-specific instruments excludes jitter related to cable attenuation. To yield comparable results, these software applications would need to similarly exclude this jitter component.

7.0 Recommendations for Measuring Jitter in SDI Signals

As noted in section 5.0, we cannot determine the jitter in a video system and its impact on system operation by making a single peak-to-peak amplitude measurement with one jitter measurement method. Assessing jitter performance in video systems requires the effective use of multiple jitter measurement methods and techniques.

In this section, we make a few recommendations for measuring jitter in three applications:

- ▶ Video system monitoring, maintenance and troubleshooting
- ▶ Video equipment qualification and installation
- ▶ Video equipment design

In these recommendations, we show how the jitter measurements made with different methods can give additional insight into the jitter characteristics of a video system.

7.1. Video system monitoring, maintenance and troubleshooting

Assessing jitter in a video system and diagnosing jitter-related problems may require measuring jitter with both the Phase Demodulation and Equivalent-time Eye methods.

Since the Phase Demodulation method continuously monitors a demodulated jitter signal, it can detect and generate alarms on a wide range of signal jitter, including peak-to-peak jitter amplitude greater than 1 UI. By including an equalization stage, instruments can monitor jitter throughout a video system and detect jitter in the equalized signal the receiver decodes.

Typical implementations of the Phase Demodulation method measure jitter over several frames of the video signal. This can capture raster-dependent deterministic jitter related to line and field rates and can catch sporadic jitter. The jitter waveform and spectrum displays available with this method can help better characterize and diagnose jitter-related problems.

Measurements made with the Equivalent-time Eye method can complement measurements made by the Phase Demodulation method. In particular, the Equivalent-time Eye method can measure the peak-to-peak amplitude of deterministic jitter at frequencies above the bandwidth of the clock recovery process used to implement the Phase Demodulation method. This high-frequency jitter may not propagate through a video system (see section 2.5), but it may affect individual link operation.

Comparing measurements from both methods can help determine a signal's jitter characteristics. Typically, measurements made with the Equivalent-time Eye method use fewer independent jitter samples than measurements made with the Phase Demodulation method. Thus, if both methods measured only random jitter, the Phase Demodulation method would usually produce a larger measurement.

So, if measurements made with the two methods agree, the signal most likely has highly regular deterministic jitter (e.g., sinusoidal jitter) and a small amount of random jitter. If the Equivalent-time Eye method consistently produces the larger measurement, the signal contains regular, high frequency deterministic jitter. If the Phase Demodulation method produces a much larger value, the signal contains some combination of narrow jitter spikes, intermittent deterministic jitter or a significant level of random jitter.

7.2. Video equipment qualification and installation

Measuring jitter with more than one method also helps in qualifying and installing new video equipment.

The benefits of the Phase Demodulation method identified above for video system monitoring, maintenance, and troubleshooting also apply in this application. With continuous, Nyquist-rate sampling of the demodulated jitter signal, this method can detect and log the effects of narrow jitter spikes, intermittent deterministic jitter, or significant levels of random jitter.

By sampling the demodulated jitter signal at the Nyquist rate, this method can collect a large number of independent jitter samples quickly. These long normalized measurement times can help assess the impact of random jitter on data error rates.

The jitter signal output available in some implementations of the Phase Demodulation method complements the internally-generated jitter signal displays. Routing this output to an oscilloscope or spectrum analyzer can reveal more details on the temporal and frequency characteristics of signal jitter.

An equalization stage also helps in equipment installation. When this stage is present, installers and engineers can measure jitter at the end of long cables. With this capability, they can evaluate jitter at the receiver's input as well as the source output. This helps detect and diagnose problems due to jitter introduced by equipment or connections

Jitter Measurement for Serial Digital Video Signals

► Primer

between the source and receiver, e.g., patch panels and non-reclocking distribution amplifiers.

The jitter noise floor in implementations of the Phase Demodulation method may be larger than implementation of other methods, primarily due to contributions from equalization and clock recovery. If the jitter in a source output signal is close to the SMPTE-specified limits, the peak-to-peak amplitude measurement may not have the resolution needed to separate sources during a precision qualification process.

In this case, peak-to-peak amplitude measurements made with an implementation of the Real-time Acquisition method can complement measurements made with the Phase Demodulation method. These implementations can have a very low noise floor. Measurements made on a single acquisition do not have contributions from equalization, clock recovery, or trigger jitter. They offer more than adequate resolution for precision screening of video equipment or components.

Implementations of the Real-time Acquisition method can also measure contributions from high-frequency deterministic jitter in a source output that the Phase Demodulation method would miss. By making a TIE measurement at each edge, the method samples this deterministic jitter above the Nyquist rate.

With multiple acquisitions, the Real-time Acquisition method can collect a large population of independent jitter samples. Peak-to-peak amplitude measurements of random jitter made with this method can complement measurements made using the Phase Demodulation method. These implementations also offer a variety of jitter displays and analysis algorithms that can help in qualifying video equipment.

In many cases, general-purpose measurement instruments that use equivalent-time sampling can substitute for an implementation of the Real-time Acquisition method in this application. Typical implementations of the Equivalent-time Eye method in video-specific equipment do not have similar capabilities and can only partially substitute for these more powerful instruments.

7.3. Video equipment design

Jitter measurements with the Real-time Acquisition and the Phase Demodulation methods best address needs in video equipment design.

With an implementation of the Phase Demodulation method, designers can functionally verify a design and make initial assessments of jitter performance. Most of the capabilities applicable to monitoring jitter in video systems, qualifying and installing video equipment, and diagnosing jitter-related problems apply in this design application. Using a common measurement method across these varied applications can help correlate design parameters with behaviors in actual video systems. The jitter waveform display of the demodulation jitter signal available with this method is especially useful for detecting raster-correlated deterministic jitter.

An implementation of the Real-time Acquisition method offers additional measurement precision and in-depth analysis capabilities that help characterize jitter behaviors. The stored acquisition record that contains a highly-sampled version of the input SDI signal offers unique benefits. Designers can isolate and examine individual edges in the SDI signal and correlate jitter behaviors with particular data patterns.

Both methods can collect a large number of independent jitter samples over reasonably short measurement times. This supports a thorough examination of random jitter and its impact on data error rates. The Phase Demodulation method can continuously monitor the demodulated jitter signal to detect jitter spikes or other intermittent deterministic jitter. Finally, both methods measure peak-to-peak jitter amplitudes greater than 1 UI.

The combined capabilities of these two jitter measurement methods offer the breadth and depth needed in video equipment design applications.

8.0 Conclusion

In this technical guide, we described the three commonly used methods for automated jitter measurement and how differences in these methods can generate dissimilar peak-to-peak jitter amplitude measurements. Variation in the number of independent jitter samples used in the peak-to-peak measurement was a common contributor to this divergence. Several other factors can bring about discrepancies and in some cases can generate significant differences.

We explored the complex nature of jitter in digital video signals and the challenges involved in measuring jitter. By gaining a better understanding of different jitter characteristics and the key elements of jitter measurement, engineers can more quickly resolve problems with signal jitter, and more fully use the varied jitter measurement and analysis solutions.

Standards bodies play a key role in evolving best practices in jitter measurement. Additional specification and guidance on jitter budgets and jitter measurement techniques are needed to ensure greater consistency in measurement results.

Additional information from video equipment manufacturers on jitter input tolerance and jitter transfer will also help in designing and qualifying video equipment that ensures low data error rates in video systems.

Tektronix remains committed to delivering high quality tools for monitoring and measuring jitter in video systems and to working with standards bodies, industry groups, video equipment manufacturers, and video network operators to address the recommendations made in this technical guide.

9.0 References

1. SMPTE RP 184-1996, *Specification of Jitter in Bit-Serial Digital Systems*
2. SMPTE RP 192-2003, *Jitter Measurement Procedures in Bit-Serial Digital Interfaces*
3. SMPTE EG 33-1998, *Jitter Characteristics and Measurements*
4. ANSI/SMPTE 259M-1997, *10-Bit 4:2:2 Component and 4fsc Composite Digital Signals — Serial Digital Interface*
5. SMPTE 292M-1998, *Bit-Serial Digital Interface for High-Definition Television Systems*
6. IEEE Std 1521™-2003, *IEEE Trial-Use Standard for Measurement of Video Jitter and Wander*
7. *Understanding and Characterizing Timing Jitter*, Tektronix Primer, 2003
8. Takeo Eguchi, *Pathological Check Codes for Serial Digital Interface Systems*, SMPTE Journal, August, 1992, pages 553-558

10.0 Acknowledgement

Tektronix wishes to gratefully acknowledge the extensive contribution of Dr. Dan H. Wolaver in the development of this technical guide.

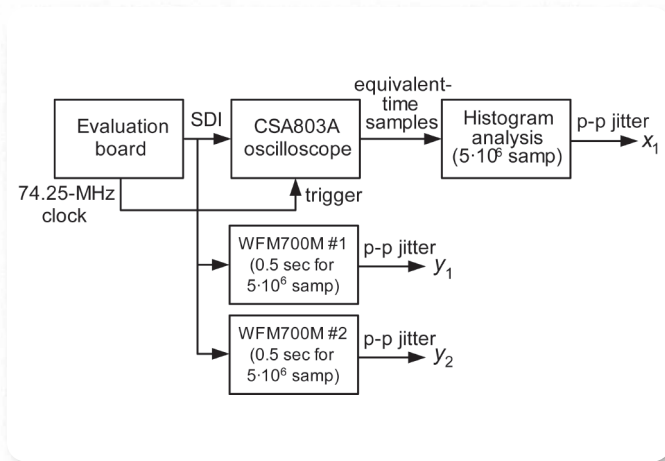

▶ **Figure A-1.** Test setup for comparing jitter measurement methods.

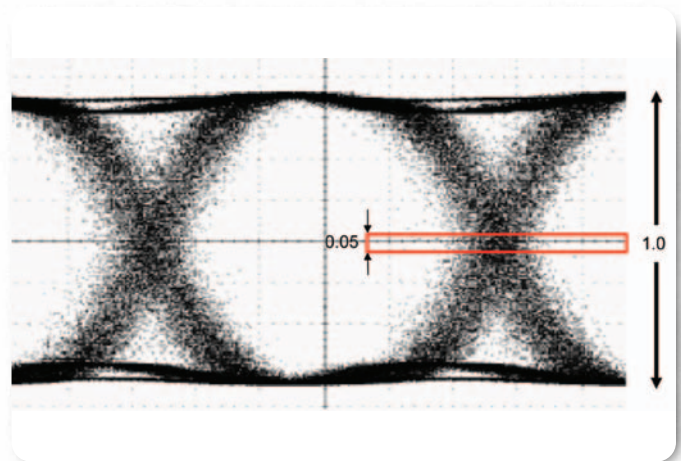

▶ **Figure A-2.** CSA803A histogram window.

Appendix A: Impact of Bandwidth Limitation in Video Jitter Measurement

In the Phase Demodulation method, the bandwidth of the clock recovery process used in the implementation determines the upper limit for jitter frequencies included in the peak-to-peak jitter amplitude measurement. The bandwidth of commonly used clock recovery hardware falls well below the 1/10 clock rate high-frequency cutoff that SMPTE specifies for measuring timing and alignment jitter. In particular, the Phase Demodulation method implemented in the Tektronix WFM700M has a 5 MHz high-frequency cutoff.

This bandwidth limitation will not significantly affect measurement results if the bandpass covers most of the jitter's spectral content. In this appendix, we describe an experiment to test the assertion that the video jitter spectrum in “typical” video signals has negligible content above common bandwidths for clock recovery.

Figure A-1 shows the test setup used for the experiment. We used the internally-generated color bar test pattern from an evaluation board for a commercially-available video IC as the test signal containing “typical” jitter. An analysis of the output test pattern from the evaluation board indicated that this signal contained predominately random jitter. The evaluation board also provided a 74.25-MHz crystal clock for triggering the oscilloscope.

We used the WFM700M to measure jitter with the Phase Demodulation method. The WFM700M determined the peak-to-peak amplitude of 5×10^6 independent jitter samples. For comparison, we made separate measurements with two WFM700Ms. The peak-to-peak jitter measurements are designated y_1 and y_2 .

We used the Tektronix CSA803A oscilloscope to measure jitter using the Equivalent-time Eye method. We configured the CSA803A to determine the peak-to-peak jitter amplitude using a histogram of 5×10^6 edge variation measurements collected within the histogram window shown in Figure A-2. The reading from the CSA803A is designated x_1 .

Jitter Measurement for Serial Digital Video Signals

► Primer

Equipment	raw measurement	intrinsic jitter	final measurement
CSA803A	$x_1 = 178$ ps p-p	$x_0 = 45$ ps p-p	$x_{act} = 172$ ps p-p
WFM700M #1	$y_1 = 164$ ps p-p		$y_1 = 164$ ps p-p
WFM700M #2	$y_2 = 170$ ps p-p		$y_2 = 170$ ps p-p

► **Table A-1.** Peak-to-peak jitter amplitude measurements.

Table A-1 shows the peak-to-peak jitter amplitudes measured by the three instruments. The three raw measurements of peak-to-peak jitter amplitude shown in this table agree within 8.5%.

Some of this difference in measurement values is due to compensation for internal jitter. The WFM700M compensates for internal jitter. The reading from the CSA803A includes uncompensated jitter noise, primarily trigger jitter, which contributes to the higher x_1 reading. This internal jitter in the CSA803A is also essentially random jitter, and is uncorrelated with the predominately random jitter in the test pattern output.

Figure A-3 shows the setup used to measure the peak-to-peak amplitude, x_0 , of this internal jitter in the CSA803A.

In order to compensate for this internal jitter (x_0) in the x_1 measurement made in this experiment, we viewed the measured jitter as the sum of two uncorrelated random jitter components, the actual random jitter in the test signal and the internal random jitter from the CSA803A. In this case, the RMS value (standard deviation) of the measured signal, σ_1 , equals the root sum of squares of the actual RMS value of the random jitter in test signal, σ_{act} , and the RMS value of the random internal jitter in the CSA803A, σ_0 .

$$\sigma_1 = \sqrt{\sigma_{act}^2 + \sigma_0^2}$$

For random jitter, the average value of the peak-to-peak jitter amplitude (J) and the RMS value (σ) are related by the equation $J = N\sigma$, where N is the normalized measurement time (section 4.5.3).

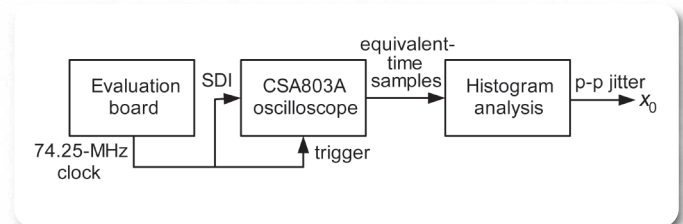

► **Figure A-3.** Test setup for calibrating the intrinsic noise x_0 of the CSA803A.

Thus:

$$\begin{aligned} J_1 &= N\sigma_1 \\ &= N\sqrt{\sigma_{act}^2 + \sigma_0^2} \\ &= \sqrt{N^2(\sigma_{act}^2 + \sigma_0^2)} \\ &= \sqrt{(N\sigma_{act})^2 + (N\sigma_0)^2} \\ &= \sqrt{J_{act}^2 + J_0^2} \end{aligned}$$

We apply this relationship between the average peak-to-peak jitter amplitude measurements to the values we measured in this experiment⁶, i.e.

$$x_1 = \sqrt{x_{act}^2 + x_0^2}, \quad x_{act} = \sqrt{x_1^2 - x_0^2}$$

Using this equation to compensate for internal jitter on the CSA803A, the final values x_{act} , y_1 , and y_2 agree within 3.5%.

The agreement among the measured values indicates that the test output from the evaluation board does not have significant jitter above the 5 MHz loop bandwidth of the clock recovery process used in the WFM700M.

We ran this experiment on a particular signal that we considered representative of typical video signals. Others could perform the same experiment on signals of interest to determine if the bandwidth limitation in the WFM700M affects the results of a peak-to-peak amplitude measurement.

⁶ In general, the peak-to-peak amplitudes of jitter sources do not add as root sums of squares. Using this approach to compensate for the internal jitter in the CSA803A produces a reasonable result in this case because the two jitter sources are uncorrelated with predominately random jitter.

Appendix B: Peak-to-Peak and RMS Measurement of Typical Video Jitter

N	J_{rms} (ps)	J_{p-p} (ps)	σ_{p-p} (ps)	J_{p-p}/J_{rms}	σ_{p-p}/J_{p-p}
3×10^3	18.8	129	5.3	6.867	4.1%
1.6×10^4	18.8	142	4.5	7.534	3.2%
5×10^5	18.8	168	3.9	8.937	2.3%
1.3×10^7	18.8	196	—	10.396	—

▶ **Table B-1.** Video jitter measurement versus jitter sample number N .

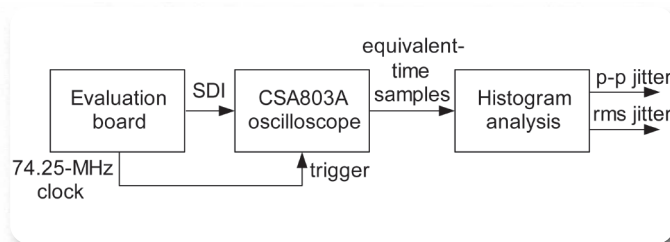

▶ **Figure B-1.** Test setup for measuring “typical” video jitter.

To illustrate the relationship between peak-to-peak amplitude measurements for purely random jitter and those for “typical” video jitter, we measured jitter on the output signal from an evaluation board for a commercially-available video IC.

Figure B-1 shows the measurement setup. We set the SDI signal output to a 1080i/60 color bar output and measured the output Eye diagram on a Tektronix CSA803A oscilloscope triggered on the 74.25-MHz crystal clock from the evaluation board. We determined that the output had negligible jitter components below 1 kHz and so did not need to implement any high-pass filtering.

We measured the RMS and peak-to-peak jitter amplitudes using the Equivalent-time Eye method (see Figure 21) with four different histograms containing $N = 3 \times 10^3$, $N = 1.6 \times 10^4$, $N = 5 \times 10^5$, and $N = 1.3 \times 10^7$ measurements of edge variation. For each of the first three values of N , we made 16 measurements to find the standard deviation between measurements. Because of the measurement time required for $N = 1.3 \times 10^7$, we only made one measurement.

Table B-1 gives the RMS jitter amplitude J_{rms} , the average peak-to-peak jitter amplitude J_{p-p} , and the standard deviation σ_{p-p} of the peak-to-peak jitter amplitude for each N . Figure 29 shows a plot of the J_{p-p}/J_{rms} and Figure 30 shows a plot of σ_{p-p}/J_{p-p} .

Jitter Measurement for Serial Digital Video Signals

► Primer

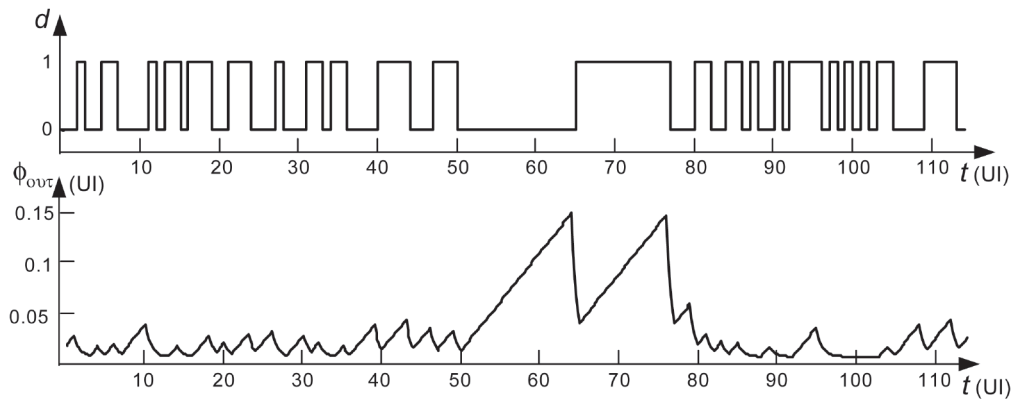

► **Figure C-1.** Data pattern d and corresponding pattern-dependent jitter f_{out} .

Appendix C: Limits to Clock Recovery Bandwidth

SMPTE 259M and SMPTE 292M specify that the high frequency cutoff of the bandpass filters used to measure timing and alignment jitter should be at least 1/10 of the data clock rate. This specification corresponds to a jitter measurement bandwidth of 148.5 MHz for HD-SDI signals and 27 MHz for SD-SDI signals.

In theory, the Phase Demodulation method could realize this cutoff if the clock recovery process used in the measurement had a bandwidth of one-tenth the bit rate. In practice, however, such a high bandwidth leads to unacceptable phase noise in the recovered clock.

Unavoidable offset in the phase detector of the phase-locked loop (PLL) used in clock recovery causes this noise. The PLL uses the signal data transitions to apply a non-zero phase at the input to cancel this offset voltage on average. In lock, then, the phase detector output has an average voltage of zero.

However, when the data pattern has no transitions (a long sequence of either '0's or '1's), the phase detector output equals the offset voltage. This offset voltage causes a frequency offset at the PLL output, corresponding to a ramp of the output phase ϕ_{out} lasting as long as the period with no transitions. This generates data-dependent jitter that corrupts the jitter measurement.

Figure C-1 illustrates this data-dependent jitter. In this example, the clock recovery bandwidth is one-tenth the bit rate and the phase detector has a 0.015 UI offset. Note that the phase ramps upward when the signal has no transitions, and it descends exponentially when the signal has transitions.

In general, we can approximate the peak-to-peak value of this data-dependent jitter by the formula:

$$\phi_{outpp} \approx 2\pi \frac{BW}{f_b} \left[2.5 \cdot \ln \left(\frac{f_b}{BW} + 457 \right) - 14.3 \right] \cdot N_{max} \cdot \phi_{off}$$

Where:

BW = the loop bandwidth of the clock recovery PLL

f_b = SDI input signal bit rate

N_{max} = the maximum period without transitions

f_{off} = the phase detector offset

For a loop bandwidth of one-tenth the bit rate, this formula becomes

$$\phi_{outpp} = 0.67 \cdot N_{max} \cdot f_{off}$$

In Figure C-1, the longest period without data transition is $N_{max} = 14$ UI, making the peak-to-peak jitter in this example equal to 0.132 UI.

An offset of $\phi_{off} = 0.015$ UI is close to the lowest value we could reasonably expect in a well-designed clock recovery circuit. Further, these circuits should allow for periods of $N_{max} = 20$ without data transitions. For $BW = 0.1 \cdot f_b$ these parameters result in $\phi_{outpp} = 0.2$ UI.

Hence, we can see that the SMPTE requirement for the high frequency cutoff of the timing and alignment jitter filters will lead to an excessive amount of internally generated clock recovery jitter in the Phase Demodulation method, especially when trying to verify conformance to a 0.2 UI limit.

From the general formula, we see that the peak-to-peak jitter amplitude decreases with decreasing loop bandwidth of the clock recovery PLL. At $BW/f_b = 0.0036$ the general formula becomes $\sigma_{outpp} \approx 0.05 \cdot N_{max} \cdot \sigma_{off}$, which gives $\sigma_{outpp} = 0.015$ UI for $\sigma_{off} = 0.015$ UI and $N_{max} = 20$. We can accept this small amount of internally generated data-dependent jitter when measuring against a 0.2 UI acceptance limit.

In the Phase Demodulation method implemented in the Tektronix WFM700M, the clock recovery PLL has a 5 MHz loop bandwidth. For 1.485 Gb/s HD-SDI signals, this corresponds to $BW/f_b = 0.0034$. Hence, this approach will generate less than 0.015 UI of internal jitter during long periods of no data transitions. For 270 Mb/s SD-SDI signals, $BW/f_b = 0.0185$ and this component of internal jitter will fall below 0.05 UI.

Contact Tektronix:

ASEAN / Australasia / Pakistan (65) 6356 3900
Austria +41 52 675 3777
Balkan, Israel, South Africa and other ISE Countries +41 52 675 3777
Belgium 07 81 60166
Brazil & South America 55 (11) 3741-8360
Canada 1 (800) 661-5625
Central East Europe, Ukraine and the Baltics +41 52 675 3777
Central Europe & Greece +41 52 675 3777
Denmark +45 80 88 1401
Finland +41 52 675 3777
France & North Africa +33 (0) 1 69 86 81 81
Germany +49 (221) 94 77 400
Hong Kong (852) 2585-6688
India (91) 80-22275577
Italy +39 (02) 25086 1
Japan 81 (3) 6714-3010
Luxembourg +44 (0) 1344 392400
Mexico, Central America & Caribbean 52 (55) 56666-333
Middle East, Asia and North Africa +41 52 675 3777
The Netherlands 090 02 021797
Norway 800 16098
People's Republic of China 86 (10) 6235 1230
Poland +41 52 675 3777
Portugal 80 08 12370
Republic of Korea 82 (2) 528-5299
Russia & CIS 7 095 775 1064
South Africa +27 11 254 8360
Spain (+34) 901 988 054
Sweden 020 08 80371
Switzerland +41 52 675 3777
Taiwan 886 (2) 2722-9622
United Kingdom & Eire +44 (0) 1344 392400
USA 1 (800) 426-2200
For other areas contact Tektronix, Inc. at: 1 (503) 627-7111
Updated 15 June 2005

For Further Information

Tektronix maintains a comprehensive, constantly expanding collection of application notes, technical briefs and other resources to help engineers working on the cutting edge of technology. Please visit www.tektronix.com



Copyright © 2005, Tektronix, Inc. All rights reserved. Tektronix products are covered by U.S. and foreign patents, issued and pending. Information in this publication supersedes that in all previously published material. Specification and price change privileges reserved. TEKTRONIX and TEK are registered trademarks of Tektronix, Inc. All other trade names referenced are the service marks, trademarks or registered trademarks of their respective companies.
10/05 EA/WOW 2BW-18906-0

Tektronix
Enabling Innovation

