

Make Safe and Accurate Measurements with High-Voltage Probes

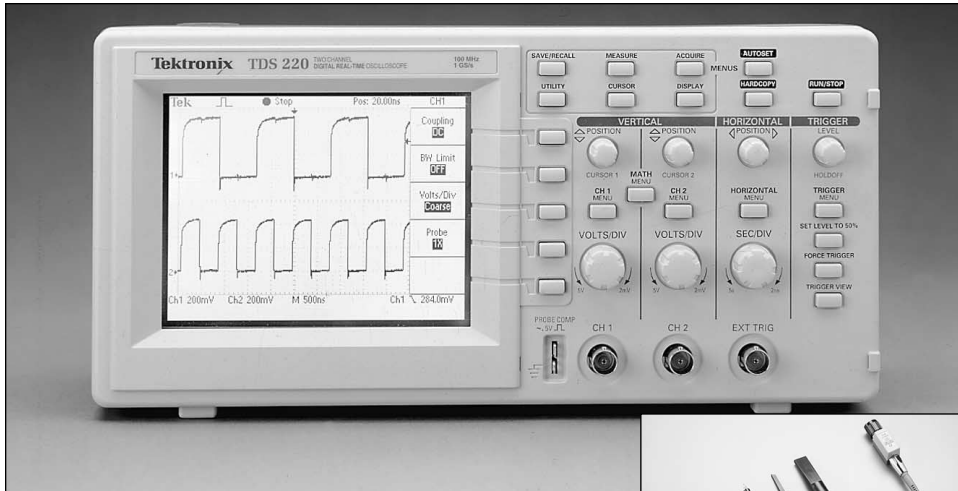

TDS 220 Digital Real-Time Oscilloscope (top); P5100 High-Voltage Probe (right).



High-voltage measurements with a general-purpose oscilloscope aren't complex or esoteric, but they do call for tools and methods different from those used in everyday testing of logic and low-power analog circuits. High-voltage measurements are important for testing switching power supplies, motor controllers, power distribution systems, and more. This application note discusses the Tektronix TDS 220 Digital Real-Time oscilloscope and the companion P5100 High-Voltage Probe and explains their use in testing diode breakdown voltages on a Robicon Motor Drive control logic board.

Choose the Right Probe for High-Voltage Measurements

For the purposes of this discussion, "high voltage" denotes any voltage that exceeds the normal range of a

conventional DSO equipped with a 10X passive probe. For the TDS 220, the maximum input voltage is 300 V RMS or 424 V DC + peak AC when using a standard P6112 Probe. Most measurements require the viewed signal to be positioned entirely within the eight vertical divisions of the scope graticule. Signals exceeding this level must be attenuated to fit within the graticule area. The P5100 High-Voltage Passive Probe is an ideal solution for this task. Its 100X attenuation raises the TDS 220's effective range to 2500 V. The P5100 is the tool of choice for safe ground-referenced measurements of high voltages. It's UL 3111-1 and IEC 1010 certified for voltages up to 2500 V (DC + peak AC). The P5100's high bandwidth (up to 250 MHz) ensures that transients and fast signal edges will be captured intact.

Moreover, the P5100 offers the rugged physical construction needed for power measurements. Its special retractable hook tip provides a positive connection on test points up to 6.5 mm in diameter.

The Unit-Under-Test

The Unit-Under-Test (UUT) is a control board within a "cell" of a Robicon Motor Drive. Robicon, Inc. is a leading manufacturer of conventional and harmonic drives for high-power AC electric motors used in air conditioning systems, oilfield pumping equipment, etc. A system may consist of many modular power cells. Each must pass rigorous manufacturing quality tests to ensure not only customer satisfaction, but also customer safety.

The cells use IGBT (Insulated Gate Bipolar Transistor) devices to deliver power to the load. These IGBTs are controlled by a logic board that is integral to the cell; the digital ICs on this board are powered by low-voltage supplies derived from the system's transformer secondary voltage. The conversion from line input level to the ± 15 VDC level needed by the logic board is handled by a local regulator. Figure 1 depicts the architecture.

The integrity of the high-voltage diode in the regulator is critical. Its breakdown voltage is rated at no less than 600 V (reverse voltage), to provide ample headroom above the nominal 460 V DC levels it will encounter in the circuit. The purpose of the manufacturing test is to ensure that the diode withstands the momentary voltage

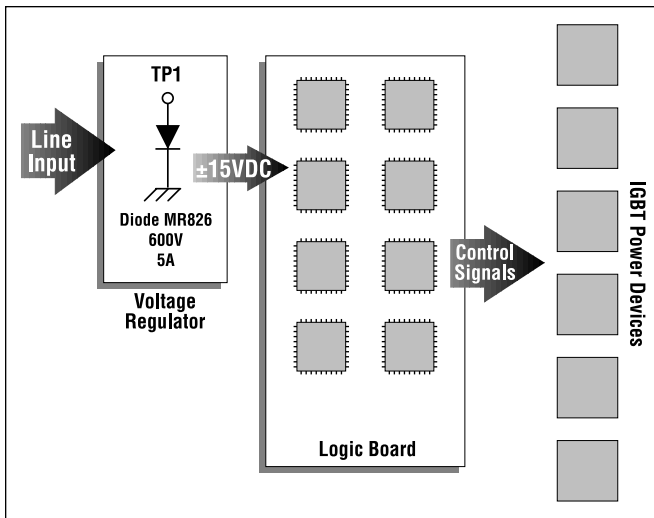

Figure 1. Simplified diagram of Robicon cell architecture.

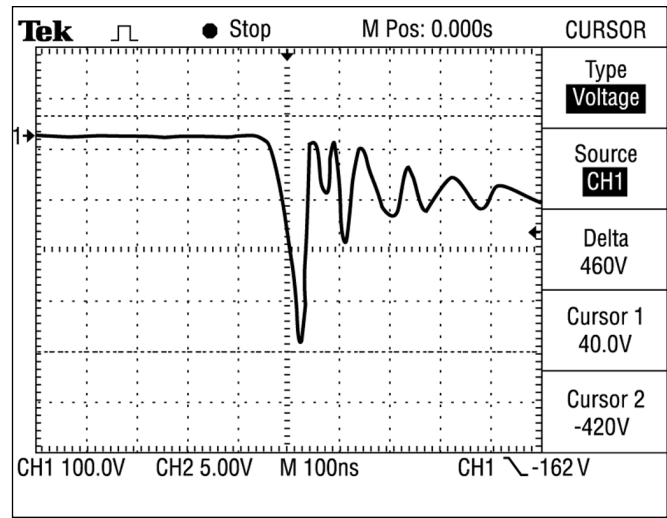

Figure 2. Typical in-rush waveform.

and inrush current conditions that occur as the system is switched on. During power-up, heavy currents flow through the diode as the power supply capacitors charge. If the diode failed, the capacitors, and possibly the logic circuitry, would receive damaging voltages.

Figure 2 shows the waveform across the diode during the in-rush cycle. The negative-going spike is caused by the massive startup load of the capacitors' charging current.



Robicon 454 GT Variable Frequency AC drive (photo courtesy of Robicon, Inc.).

The P5100's attenuation (100X) keeps the waveform amplitude well within the graticule limits. Note that once the probe type is selected from the scope's menu, it scales its readings accordingly. Thus the scope's 1 V/Div setting becomes 100 V/Div. The cursors also recognize the scaling. The typical manufacturing test sets the cursors at the limits of the specification (the TDS 220 stores such setups for instant recall). The UUT passes the test if the waveform falls between the cursors. If quantified readings are required, the operator can line up the cursors with the waveform peaks and take a "Delta" reading of the measured voltage between the cursors. The result appears to the right of the waveform window.

A Few Words About Floating Measurements

Many power circuits do not provide an appropriate earth ground point for the passive probe ground lead. For example, when the circuit discussed above is installed into a system such as Robicon's

Perfect Harmony motor drives, the cathode of the diode is connected to a common point that is not an earth ground. Its potential may be hundreds or even thousands of volts. This is known as a "floating" circuit, and line-powered scopes with passive single-ended probes offer no safe means of measuring the voltage across the diode in this situation.

There are two safe solutions for this problem. Line-powered scopes can be fitted with an isolating differential probe such as the Tektronix P5200 High-Voltage Differential Probe. Neither lead is fixed at earth ground. The probe measures the difference voltage across the two terminals, ignoring the offset voltage common to both.

The second choice is a fully-isolated, battery-powered scope such as the handheld Tektronix THS 720P. Again, neither probe lead is fixed at earth ground, and the instrument itself is not connected to ground.

For further information, contact Tektronix:

World Wide Web: <http://www.tek.com>; ASEAN Countries (65) 356-3900; Australia & New Zealand 61 (2) 888-7066; Austria, Eastern Europe, & Middle East 43 (1) 7 0177-261; Belgium 32 (2) 725-96-10; Brazil and South America 55 (11) 3741 8360; Canada 1 (800) 661-5625; Denmark 45 (44) 850700; Finland 358 (9) 4783 400; France & North Africa 33 (1) 69 86 81 81; Germany 49 (221) 94 77-0; Hong Kong (852) 2585-6688; India 91 (80) 2275577; Italy 39 (2) 250861; Japan (Sony/Tektronix Corporation) 81 (3) 3448-4611; Mexico, Central America, & Caribbean 52 (5) 666-6333; The Netherlands 31 23 56 95555; Norway 47 (22) 070700; People's Republic of China (86) 10-62351230; Republic of Korea 82 (2) 528-5299; Spain & Portugal 34 (1) 372 6000; Sweden 46 (8) 629 6500; Switzerland 41 (41) 7119192; Taiwan 886 (2) 765-6362; United Kingdom & Eire 44 (1628) 403300; USA 1 (800) 426-2200

From other areas, contact: Tektronix, Inc. Export Sales, P.O. Box 500, M/S 50-255, Beaverton, Oregon 97077-0001, USA (503) 627-1916

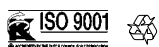

Copyright © 1997, Tektronix, Inc. All rights reserved. Tektronix products are covered by U.S. and foreign patents, issued and pending. Information in this publication supersedes that in all previously published material. Specification and price change privileges reserved. TEKTRONIX and TEK are registered trademarks.