

Choosing an Oscilloscope for Coherent Optical Modulation Analysis

Technical Brief

As demand for data increases, network operators continue to search for methods to increase data throughput of existing optical networks. As data rates increase to 40Gb/s, 100Gb/s, and beyond, complex modulation formats become prevalent. These modulation formats present new challenges for the designer when it comes to choices of test equipment.

This Technical Brief will outline the basic technologies used to convert complex modulated optical signals to electrical signals capable of being acquired by an oscilloscope. Further explanation of coherent detection techniques will be discussed and why real-time or equivalent-time scopes may be chosen. Finally, a number of equipment configurations will be shown that support coherent demodulation and analysis.

Tektronix[®]

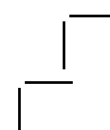

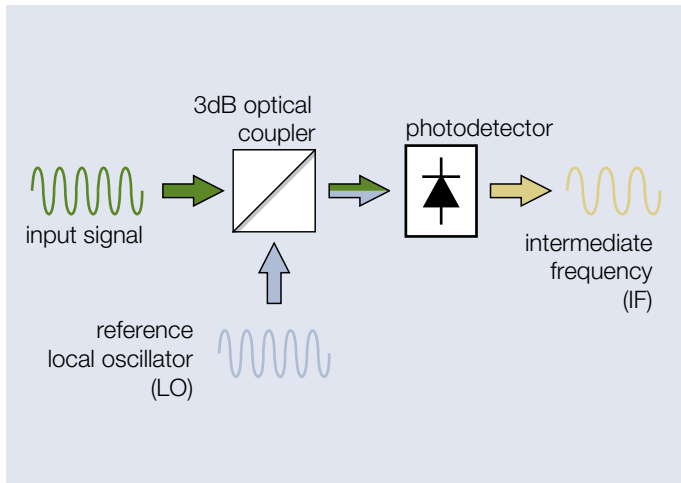
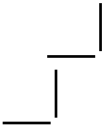

Figure 1. Fundamental building blocks of coherent demodulation.

Coherent Receiver Basics

Complex modulation formats such as BPSK, QPSK, QAM, and DP-QPSK typically utilize C-band or L-band lasers as the optical carrier. These lasers operate at frequencies between 186THz and 196THz. Obviously no oscilloscope is capable of directly measuring these frequencies. Additionally, these complex modulation formats carry information in both the phase and polarization of the optical carrier.

Coherent receivers fulfill two necessary functions. First, they downconvert the optical carrier to an intermediate frequency capable of being acquired by a modern oscilloscope. Second, they use coherent detection techniques to recover not only the amplitude of the optical carrier, but also the phase and state of polarization.

The underlying principle behind coherent detection, and the resulting signal downconversion, is the mixing of the signal carrier with a local oscillator (LO) and the resultant detection of the beat frequency by a photodetector. The result of the mixing is a difference frequency (the intermediate frequency, IF) which has the same amplitude, phase, and polarization of the original carrier but at a lower frequency, as shown in Figure 1.

The photodetector generates an electrical current proportional to the power of the optical signal but independent of phase or polarization. Modulation formats such as QPSK (quadrature

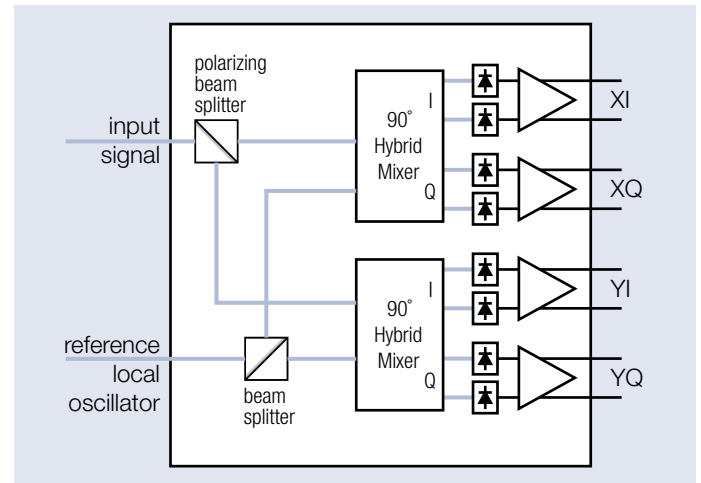

Figure 2. Block diagram of a phase/polarization-diversity receiver.

phase shift keying) encode information in both the in-phase (I) and quadrature phase (Q) of the optical carrier. To maximize the signal photocurrent and to cancel out the DC component, balanced detection is often used. The resulting photocurrent is directly proportional to the component of the signal which is in-phase with the reference. The signal is also mixed with a 90° phase-shifted reference on a second balanced photodiode pair to obtain the portion of the signal in quadrature to the reference.

The combination of the components for the beam-splitting, phase-shifting, and mixing is commonly referred to as a 90° optical hybrid. The combination of two photodetector pairs at the output of the 90° optical hybrid forms the basis of a simple phase-diversity coherent receiver front end.

Dual-polarized QPSK (DP-QPSK) doubles the effective data rate of QPSK by combining two QPSK signals with orthogonal polarization. In order to detect both polarizations, two separate 90° optical hybrids are used. The LO is passed through a beam splitter (BS) to both hybrids. The input signal is passed through a polarizing beam splitter which presents input signals to the hybrids that are orthogonally polarized with respect to each other.

This combination is referred to as a phase/polarization diversity receiver and is shown in Figure 2.

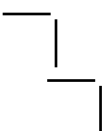

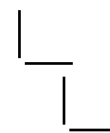

Choosing an Oscilloscope for Coherent Optical Modulation Analysis

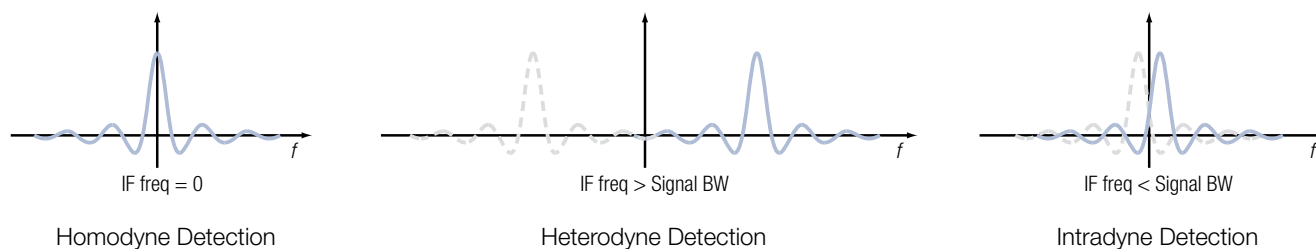

Figure 3. Coherent demodulation techniques.

Coherent Demodulation Techniques

Often dependent upon system configuration or the type of oscilloscope available, coherent receivers may employ different demodulation techniques as described below.

Homodyne detection

Stable interference between the reference and the input carrier is only possible when the two are at precisely the same frequency. This is referred to as homodyne detection and results in the input signal being downconverted to an IF centered at zero. In radio frequency applications, locking the frequency of the two signals together is accomplished via a phase-locked loop. An optical phase-locked loop is not very practical. Therefore, for homodyne detection to work, the same laser carrier used for the signal modulator must be split and also used as the reference. (See Figure 3.) If the application makes possible this type of coherent reference, homodyne detection may be effectively used.

Heterodyne detection

In other applications, the laser feeding the signal modulator and the modulator itself are effectively a sealed unit, or are physically located a long distance from the receiving/testing point. In this case, there is no practical manner to lock the LO to the input signal carrier. When the LO frequency is chosen such that the resulting IF is much greater than the bandwidth of the signal, the receiver is said to employ heterodyne detection. To ensure that the positive and negative signal frequency components do not overlap, an IF of greater than 3 times the signal bandwidth is necessary. The difficulty with pure heterodyne detection is that this resulting IF far exceeds the bandwidth of practical oscilloscopes for high data-rate signals.

Intradyne detection

When the IF is less than the bandwidth of the signal, the detection technique is called intradyne detection. In this case the positive and negative signal frequency components overlap. If the sample rate of the acquisition system (the oscilloscope) is high enough – as with real-time oscilloscopes – digital signal processing algorithms can be used to separate the positive and negative components. DSP is also necessary to compensate for drifts in phase and frequency of the carriers relative to each other.

In practical applications, the LO is set to as close as possible to the same frequency of the input signal carrier. This is done to keep the IF as low as possible so the entire signal can be kept within the bandwidth of the oscilloscope. Even if the LO and the signal carrier are set to be the same frequency, this is not homodyne detection because the LO and signal carrier are not locked to each other and will each slightly drift in frequency and phase. Typical network lasers have frequency accuracy specified around 2-GHz with frequency noise spectra also in the GHz regime, so a high sample rate oscilloscope and DSP are still required.

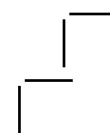

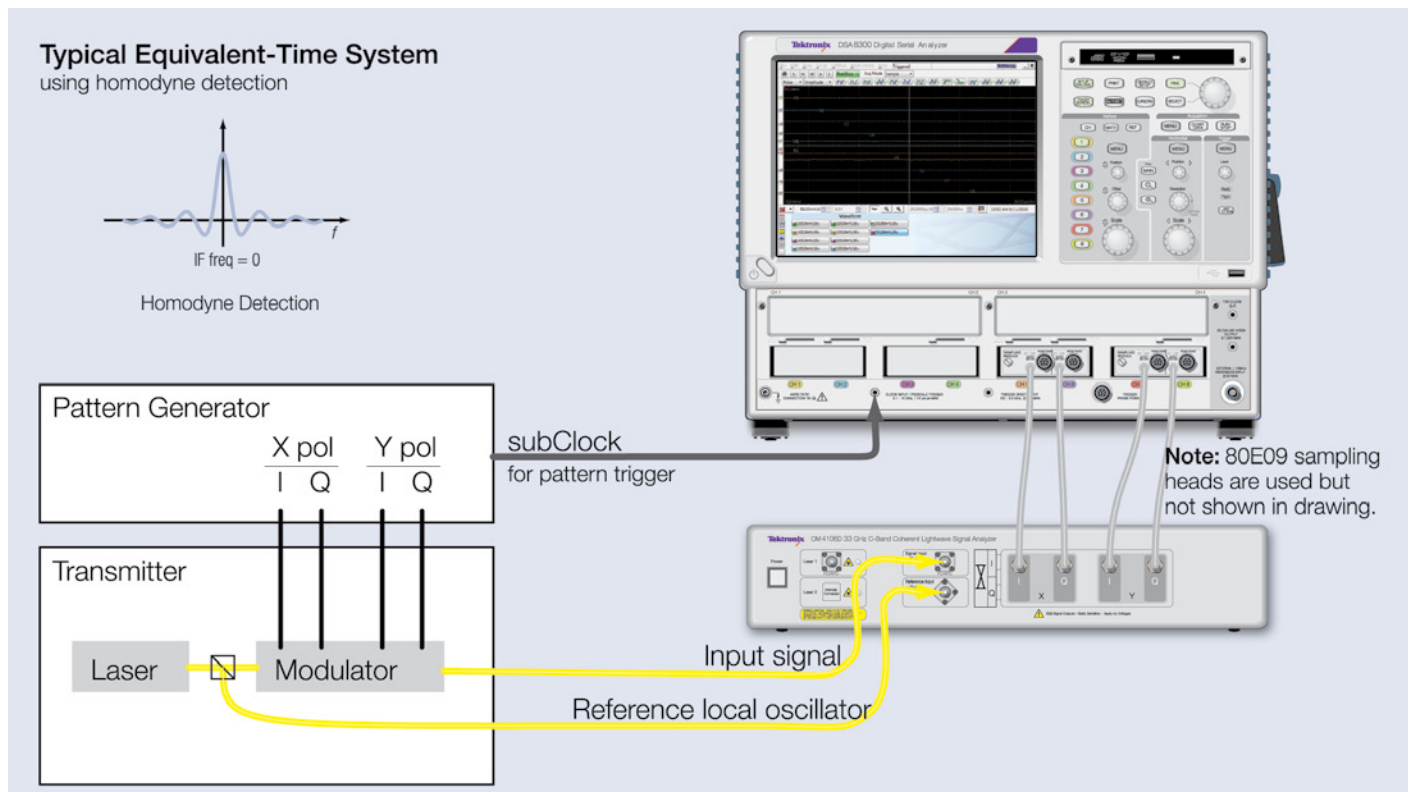
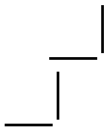

Figure 4. Example equivalent-time oscilloscope system configuration using homodyne detection and showing connection of the reference local oscillator.

Instrument Choices for Coherent Modulation Signal Analysis

Equivalent-time Oscilloscopes

When access to the input to the modulator is possible, homodyne detection is possible. For example, modulator component manufacturers, or those developing integrated laser/modulator, often have such access to the input of the modulator. A high sample rate oscilloscope is not required. In this case an equivalent-time oscilloscope may be used.

There are several benefits to using an equivalent-time oscilloscope. Equivalent-time oscilloscopes commonly employ 16-bit A/D converters which offer high vertical resolution resulting in greater dynamic range and measurement accuracy. Equivalent-time oscilloscopes typically have a lower noise floor and less jitter than their real-time oscilloscope counterparts. Another benefit is price. Equivalent-time oscilloscopes typically cost less than real-time oscilloscopes to achieve the same bandwidth.

An example of the equivalent-time scope configured into a measurement system is shown in Figure 4.

Real-time Oscilloscopes

In other applications, access to the input of the modulator may not be practical or even possible. For instance, if the transmitter is located physically far away from the testing site, or if significant lengths of fiber optic cable are simulating real-world environments. For some manufacturers, such as those developing coherent receivers or complete systems, access to the modulator may not be possible. In these cases, homodyne detection is not possible, and intradyne detection must be used which requires a real-time oscilloscope. The high sample rate of real-time oscilloscopes can appropriately acquire the downconverted signal and compensate for frequency and phase drifts in software. This is shown in Figure 5.

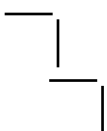



Choosing an Oscilloscope for Coherent Optical Modulation Analysis

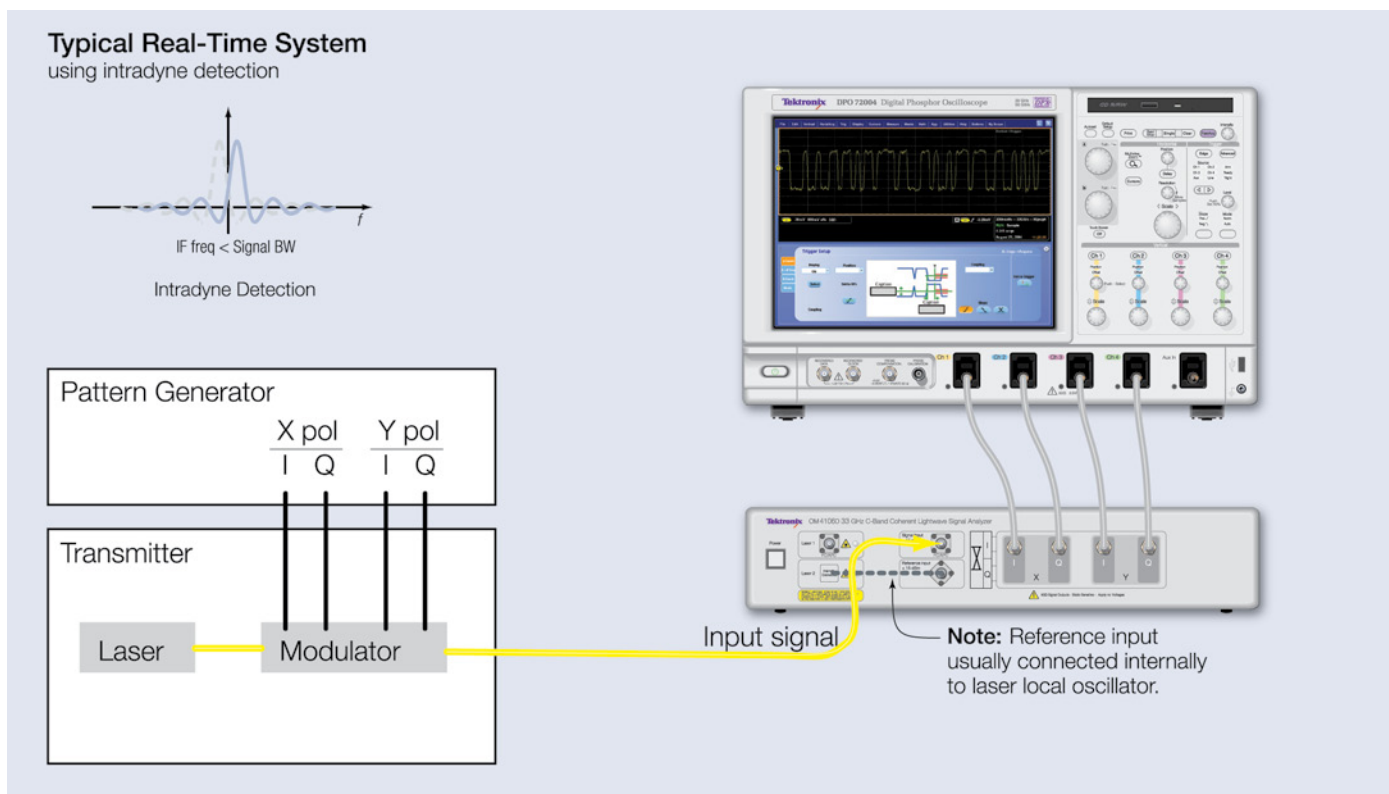

Figure 5. Example real-time oscilloscope system using intradyne detection.

Coherent Receivers

For many situations, a precise, “laboratory-grade” coherent receiver is a key instrument in the testing configuration. For many transmitter manufacturers, for instance, the skill set necessary to develop a coherent receiver – along with software algorithms and tools – is not available internally. Even receiver manufacturers often have the need for a receiver instrument to use as a golden reference by which to evaluate their own products.

Coherent receiver instruments are available from a number of different manufacturers. Some of these instruments are capable of only supporting homodyne detection and are limited to the use of equivalent-time scopes only. These instruments are often not practical for a range of applications in which access to the modulator input is not possible.

Other receiver instruments support only real-time oscilloscopes. While they do not require access to the modulator input, there are still a number of applications in which these systems are not appropriate. Some applications require the higher vertical accuracy that only an equivalent-time scope can provide.

The ideal coherent receiver can support both equivalent-time and real-time oscilloscopes. This instrument is applicable in the broadest range of applications. It offers the customer the freedom to choose to use the high-dynamic range of equivalent-time scopes for one suite of tests, and then place their device in a more real-world, system-level test and use a real-time scope when access to the modulator input is not practical.

Conclusion

Deployment of coherent modulation techniques creates new challenges in configuration of test systems. Use of equivalent-time oscilloscopes offers the highest vertical resolution and lowest noise. The use of real-time oscilloscopes permit intradyne detection which eliminates the need for access to the input of the modulator. Coherent receivers are available to support both equivalent-time and real-time oscilloscopes, but the choice of a receiver that can support both offers the greatest flexibility.

Sample configurations with equivalent-time oscilloscopes and real-time oscilloscopes, along with the Tektronix OM4000 series coherent receiver capable of supporting both, are shown on the following pages.

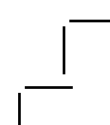

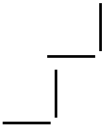

Sample Equivalent-Time System Instrument Configurations

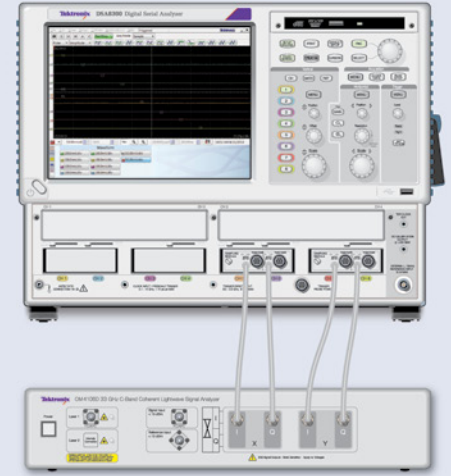

28 Gbaud signals¹ (maximum detectable baud rate² 40 Gbaud)

Coherent Receiver	OM4006D 23GHz Coherent Lightwave Signal Analyzer , works with both equivalent-time and real-time oscilloscopes opt EXT required for equivalent-time scope applications
Oscilloscope	DSA8300 Digital Serial Analyzer Equivalent-time Oscilloscope opt. ADVTRIG Advanced Trigger with Pattern Sync required Single Polarization: 80E07 30GHz Equivalent-time Module, quantity 1 needed, or Dual Polarization: 80E07 30GHz Equivalent-time Module, quantity 2 needed

32 Gbaud signals¹ (maximum detectable baud rate² 50 Gbaud)

Coherent Receiver	OM4106D 33GHz Coherent Lightwave Signal Analyzer , works with both equivalent-time and real-time oscilloscopes opt EXT required for equivalent-time scope applications
Oscilloscope	DSA8300 Digital Serial Analyzer Equivalent-time Oscilloscope opt. ADVTRIG Advanced Trigger with Pattern Sync required Single Polarization: 80E07 30GHz Equivalent-time Module, quantity 1 needed, or Dual Polarization: 80E07 30GHz Equivalent-time Module, quantity 2 needed

40 Gbaud signals¹ (maximum detectable baud rate² 60 Gbaud)

Coherent Receiver	OM4106D 33GHz Coherent Lightwave Signal Analyzer , works with both equivalent-time and real-time oscilloscopes opt EXT required for equivalent-time scope applications
Oscilloscope	DSA8300 Digital Serial Analyzer Equivalent-time Oscilloscope opt. ADVTRIG Advanced Trigger with Pattern Sync required Single Polarization: 80E07 30GHz Equivalent-time Module, quantity 1 needed, or Dual Polarization: 80E07 30GHz Equivalent-time Module, quantity 2 needed

¹With a signal Q-factor of 20dB

²With a signal Q-factor of 9.5dB

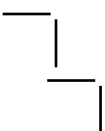



Sample Equivalent-Time System Instrument Configurations

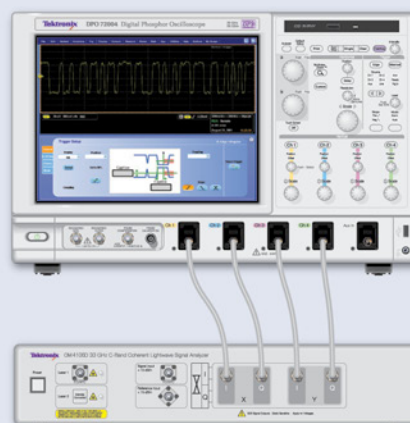

28 Gbaud signals¹ (maximum detectable baud rate² 40 Gbaud)

Coherent Receiver	OM4006D 23GHz Coherent Lightwave Signal Analyzer , works with both equivalent-time and real-time oscilloscopes opt EXT required for equivalent-time scope applications
Oscilloscope	DP072004C 20GHz Digital Phosphor Oscilloscope supports single and dual polarization systems

32 Gbaud signals¹ (maximum detectable baud rate² 50 Gbaud)

Coherent Receiver	OM4106D 33GHz Coherent Lightwave Signal Analyzer , works with both equivalent-time and real-time oscilloscopes opt EXT required for equivalent-time scope applications
Oscilloscope	DP072504D 25GHz Digital Phosphor Oscilloscope supports single and dual polarization systems

40 Gbaud signals¹ (maximum detectable baud rate² 60 Gbaud)

Coherent Receiver	OM4106D 33GHz Coherent Lightwave Signal Analyzer , works with both equivalent-time and real-time oscilloscopes opt EXT required for equivalent-time scope applications
Oscilloscope	Single Polarization: DP073304D 33GHz Digital Phosphor Oscilloscope Dual Polarization: DP073304D 33GHz Digital Phosphor Oscilloscope , requires quantity 2

¹With a signal Q-factor of 20dB
²With a signal Q-factor of 9.5dB

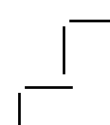

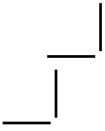

Contact Tektronix:

- ASEAN / Australasia (65) 6356 3900
- Austria* 00800 2255 4835
- Balkans, Israel, South Africa and other ISE Countries +41 52 675 3777
- Belgium* 00800 2255 4835
- Brazil +55 (11) 3759 7627
- Canada 1 (800) 833-9200
- Central East Europe and the Baltics +41 52 675 3777
- Central Europe & Greece +41 52 675 3777
- Denmark +45 80 88 1401
- Finland +41 52 675 3777
- France* 00800 2255 4835
- Germany* 00800 2255 4835
- Hong Kong 400-820-5835
- India 000-800-650-1835
- Italy* 00800 2255 4835
- Japan 81 (3) 6714-3010
- Luxembourg +41 52 675 3777
- Mexico, Central/South America & Caribbean 52 (55) 56 04 50 90
- Middle East, Asia and North Africa +41 52 675 3777
- The Netherlands* 00800 2255 4835
- Norway 800 16098
- People's Republic of China 400-820-5835
- Poland +41 52 675 3777
- Portugal 80 08 12370
- Republic of Korea 001-800-8255-2835
- Russia & CIS +7 (495) 7484900
- South Africa +27 11 206 8360
- Spain* 00800 2255 4835
- Sweden* 00800 2255 4835
- Switzerland* 00800 2255 4835
- Taiwan 886 (2) 2722-9622
- United Kingdom & Ireland* 00800 2255 4835
- USA 1 (800) 833-9200

* If the European phone number above is not accessible, please call +41 52 675 3777

Contact List Updated 10 February 2011

For Further Information

Tektronix maintains a comprehensive, constantly expanding collection of application notes, technical briefs and other resources to help engineers working on the cutting edge of technology. Please visit www.tektronix.com



Copyright © 2012, Tektronix. All rights reserved. Tektronix products are covered by U.S. and foreign patents, issued and pending. Information in this publication supersedes that in all previously published material. Specification and price change privileges reserved. TEKTRONIX and TEK are registered trademarks of Tektronix, Inc. All other trade names referenced are the service marks, trademarks or registered trademarks of their respective companies.

07/12 EA/WWW

85W-28243-0

