

Optical Receiver Testing Made Easy

with the new **Tektronix 67 GHz Optical
Coherent Receiver Test System**

Perform comprehensive characterization of dual polarization intradyne coherent receiver components

- Fully automated and calibrated rack-mounted system
- Replaces expensive Lightwave Component Analyzer
- Ready for high-volume production and component verification
- Comprehensive performance verification according to OIF coherent receiver implementation agreements
- Substantially shorter test time than Lightwave Component Analyzer

System Features

Real-life signaling conditions

- True heterodyne signal stimulus
- 100% modulation depth vs. low level amplitude in VNA
- Time domain acquisition equals digitizing the output signal

Ready for production test

- Production friendly and easy to use
- Capable of simultaneous characterization of all 4 output lanes of an intradyne coherent receiver
- Contact check test included for MFG test

Accurate Optical Component Test Results

- Magnitude and phase response
- Skew errors & gain errors
- THD, CMRR, differential group delay

Test equipment is shipped in a **rack system with extendable monitor arm** for in-lab analysis.



System Installation, Training and Service

Tektronix supports you during installation and operator training of the test system in your laboratory or manufacturing facility. Our field application engineers are available on-site to provide expert level support for measurement connectivity, oscilloscope operation and analysis tool insights.



Perform OIF Specified Standard Measurements

Tektronix supports a wide range of optical long-haul and Datacom standards, including OIF-DPC-MRX and -RX (implementation agreements for dual polarization intradyne coherent receivers).



Faster Throughput for Manufacturing Excellence

Tektronix has optimized system throughput to provide a 3x improvement in test time over traditional Lightwave Component Analyzers; enabling manufacturing teams to ship higher volumes at lower cost.

Tektronix Optical Coherent Receiver Test System

Example of a fully configured automated 67 GHz test system

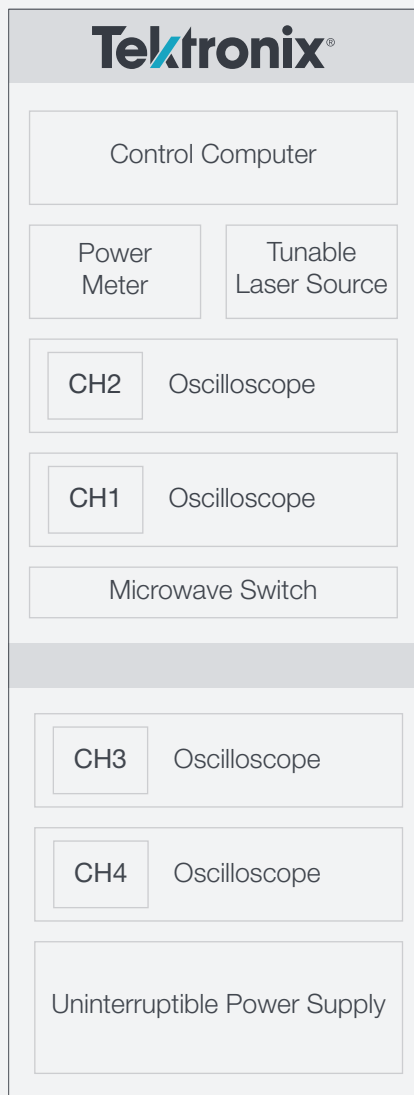

The system can be shipped in a 19" rack with working tray

The entire installation process is supported on-site by experienced Tektronix Field Applications Engineers. Three year warranties are available along with other premium service options.

MAIN COMPONENTS

Tunable Laser Source

The OM2210 provides a true heterodyne stimulus in either C- or L-band wavelengths. The high-speed tuning capability allows optical components to be quickly characterized over wide frequency range.

Real-Time Oscilloscopes

The system can be configured with up to four oscilloscopes that provide an analog bandwidth of up to 70 GHz and a sample rate of up to 200 GS/s. The Tektronix patented ATI technology keeps noise at a minimum level.

Microwave Switch

With four 2x1 switching relays, the system supports characterization of DUTs with up to 8 electrical output lanes (e.g. four differential channels).

Control Computer

Equipped with comprehensive control and analysis SW, the PC controls all elements of the system and performs automatic data acquisition, processing and visualization of test results.

Uninterruptible Power Supply

To help our customers in avoiding loss of data and shortening production down-time in case of power failures, the system can be optionally configured with an uninterruptible power supply.

KEY ADVANTAGES

Compared to powermeter-based solution

- Magnitude and phase information is gathered by the system (powermeter measures magnitude only)
- Non-linearities can be characterized

Compared to traditional LCA approach

- Measure 4 lanes simultaneously (LCA measures single lane only, thus 4 successive scans are required)
- Stimulus represents real-life signal conditions DUT will see (LCA provides small modulation amplitude riding on large DC which is not representative)

YOUR BENEFIT

Save time and improve throughput of your production testing. Use real-life signaling conditions and characterize your optical components faster. Profit from customizable solutions that meet your specific requirements.

Tektronix Optical Coherent Receiver Test System

System Flexibility to Support Different Needs

Tektronix recognizes the different needs from research, development and manufacturing, and enables customers to configure the system according to their specific requirements.

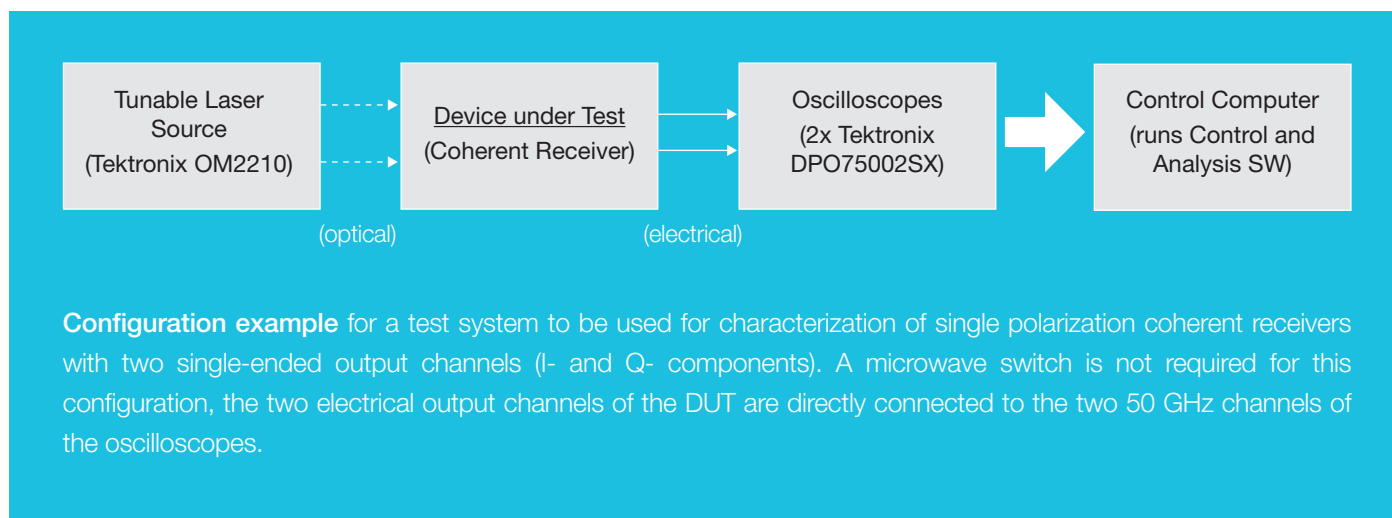
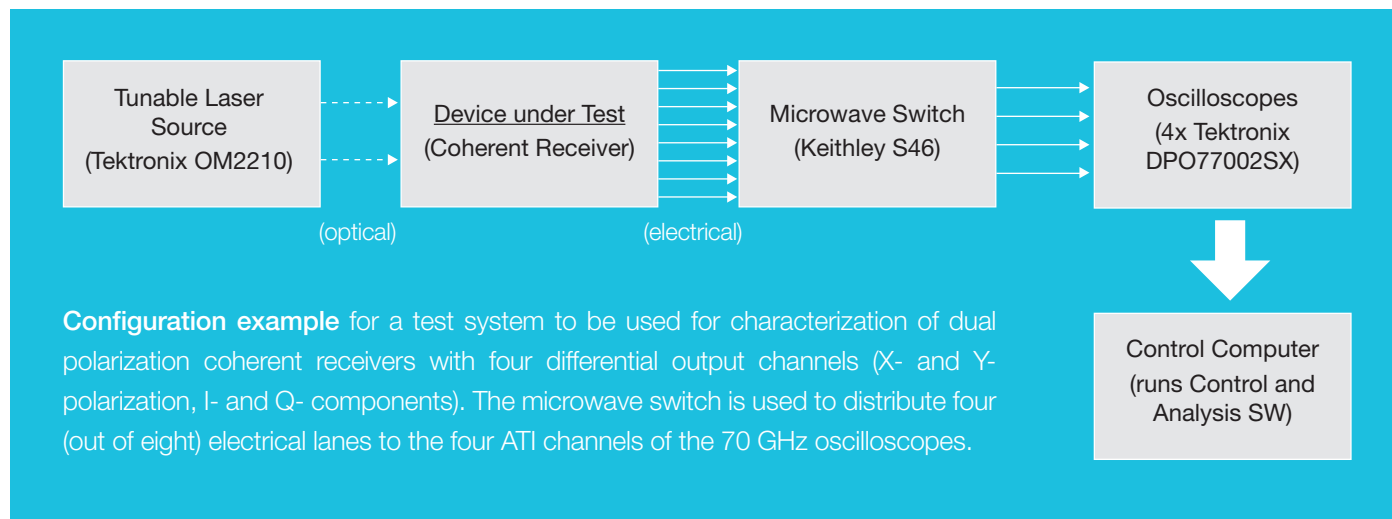

Your application has requirements not met by the configuration examples above? Please contact your local Tektronix sales representative to discuss customization options to address your specific needs.

See tek.com/contact-us for contact information

Visit tek.com

Tektronix Optical Coherent Receiver Test System



Tektronix oscilloscopes with patented Asynchronous Time Interleaving (ATI) technology provide low noise, high fidelity and high bandwidth performance.

PERFORMANCE OF THE TEKTRONIX OPTICAL COHERENT RECEIVER TEST SYSTEM

Frequency Range Options	33 GHz, 50 GHz or 67 GHz
Digitization	4 channels with up to 70 GHz analog bandwidth
Sample Rate	Up to 200 GS/s
Resolution	8 bits
Memory Depth	62.5 Mpoint standard, 1Gpoint Max
Optical Input Power (dBm)	
LO	Max +16 dBm
Signal	Max + 12 dBm
Optical Input Connectors	FC/APC Standard
Included Narrow Linewidth Lasers	Two C- or two L-band lasers with fast wavelength tuning capability (via the included OM2210 Coherent Receiver Calibration Source)
Linewidth	100 kHz
Maximum Power Output	15.5 dBm
C-band Tuning Range	1527.60 nm to 1567.54 nm
L-band Tuning Range	1567.54 nm to 1609.62 nm
Supported Measurements	Optical-to-electrical transfer function, third harmonic distortion (THD), common mode rejection ratio (CMRR), differential group delay; Complete characterization of the polarization-diverse hybrid: quadrature phase angle, polarization cross-talk, path gains, IQ skew errors