

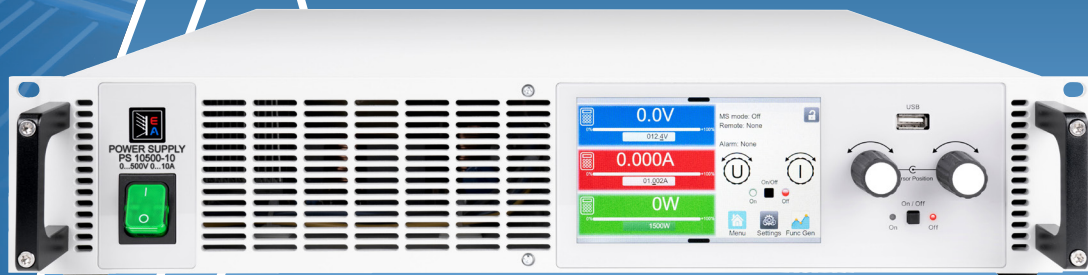

Elektro-Automatik



USER MANUAL

EA-PS 10000 2U

Programmable DC power supplies

Use, Remote Control

TABLE OF CONTENTS

1. General	
1.1 About this document	4
1.1.1 Preamble	4
1.1.2 Copyright	4
1.1.3 Validity	4
1.1.4 Symbols and warnings	4
2. Operation and application (2)	
2.1 Operating modes	5
2.1.1 Voltage control / Constant voltage	5
2.1.2 Current control / constant current / current limiting	5
2.1.3 Power control / constant power / power limiting	6
2.1.4 Internal resistance control	6
2.1.5 Actual value filter	7
2.1.6 Fast discharge	7
2.1.7 STBY zero stabilization	8
2.2 Manual operation (2)	9
2.2.1 Configuration via the menu	9
2.2.2 Adjustment limits	18
2.2.3 Changing the operating mode	18
2.2.4 Recording to USB stick (logging)	19
2.2.5 The quick menu	20
2.2.6 Loading and saving user profiles	21
2.2.7 The graph	22
2.3 Remote control	23
2.3.1 General	23
2.3.2 Control locations	23
2.3.3 Remote control via a digital interface	23
2.3.4 Remote control via the analog interface	25
3. Other applications (2)	
3.1 Parallel operation in master-slave (MS)	30
3.1.1 Restrictions	30
3.1.2 Wiring the DC outputs	30
3.1.3 Wiring the Share-Bus	31
3.1.4 Wiring and set-up of the master-slave bus	31
3.1.5 Mixed systems	32
3.1.6 Configuring the master-slave operation	32
3.1.7 Operating the master-slave system	33
3.1.8 Alarms and other problem situations	33
3.2 SEMI F47	34
3.2.1 Restrictions	34
3.2.2 Adjustments	34
3.2.3 Application	34
4. Service and maintenance (2)	
4.1 Firmware updates	35

Attention! The part of this document that deals with the handling of features on the control panel is only valid for devices with firmwares "KE: 3.10", "HMI: 4.09" and "DR: 1.0.2.20" or higher.

1. General

1.1 About this document

1.1.1 Preamble

Together with the separate installation manual, this document builds the documentation for use and control of the devices as listed in section «1.1.3 Validity». It explains manual operation and other control related features.

1.1.2 Copyright

Reprinting, copying, also partially, usage for other purposes as foreseen of this document are forbidden and breach may lead to legal consequences.



1.1.3 Validity

This document is valid for the following equipment including derived variants:

Model	Model	Model
EA-PS 10060-60 2U	EA-PS 10750-06 2U	EA-PS 10500-20 2U
EA-PS 10080-60 2U	EA-PS 10060-120 2U	EA-PS 10750-12 2U
EA-PS 10200-25 2U	EA-PS 10080-120 2U	EA-PS 11000-10 2U
EA-PS 10360-15 2U	EA-PS 10200-50 2U	EA-PS 11500-06 2U
EA-PS 10500-10 2U	EA-PS 10360-30 2U	

1.1.4 Symbols and warnings

Warning and safety notices as well as general notices in this document are shown in a box with a symbol as follows:

	Symbol for general safety notices (instructions and damage protection bans) or important information for operation
	Symbol for general notices

2. Operation and application (2)

2.1 Operating modes

A device like this is internally controlled by different control circuits, which shall regulate voltage, current and power to the adjusted values and hold them constant, if possible. These circuits follow typical laws of control systems engineering, resulting in different operating modes. Each operating mode has its own characteristics which are explained below in short form.



- *Unloaded operation isn't considered as a normal operation mode and can thus lead to false measurements, for example when calibrating the device*
- *The optimal working point of the device is between 50% and 100% voltage and current*
- *It's recommended to not run the device below 10% voltage and current, in order to meet technical values like ripple or transient times*

2.1.1 Voltage control / Constant voltage

Voltage control is also called constant voltage operation (short: CV).

The DC output voltage of a power supply is held constant on the adjusted value, unless the output current or the output power according to $P = U_{OUT} * I_{OUT}$ reaches the adjusted current or power limit. In both cases the device will automatically change to constant current or constant power operation, whatever occurs first. Then the output voltage can't be held constant anymore and will sink to a value resulting from Ohm's law.

While the DC output is switched on and constant voltage mode is active, then the condition "CV mode active" will be indicated on the graphic display by the abbreviation **CV** and this message will be passed as a signal to the analog interface, as well stored as status which can also be read via digital interface.

2.1.1.1 Voltage control peaks

When working in constant voltage control (CV), the device's internal voltage regulator requires a small transient time to settle the voltage after a load step. Negative load steps, i.e. high load to lower load, will cause the output voltage to overshoot for a short time until compensated by the voltage regulator. The time it takes to settle the voltage can be influenced by switching the voltage control speed between the settings **Slow**, **Normal** and **Fast**, whereas Normal is the default. Setting **Slow** will result in a higher transient time and higher voltage drop, but less overshooting, where **Fast** is vice versa. See «2.2.1.1 Sub menu "Settings"».

Depictions:

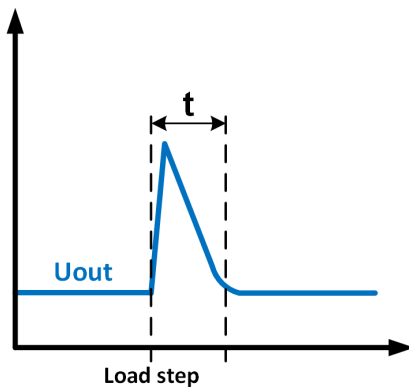

Example for a neg. load step: the DC output will rise above the adjusted value for a short time. t = transient time to settle the output voltage.

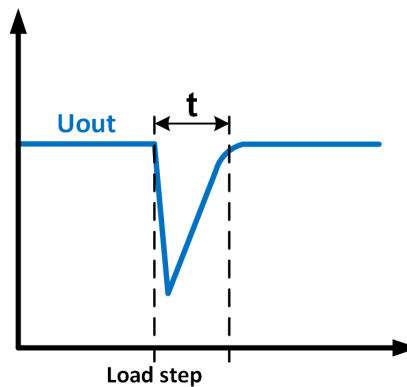

Example for a pos. load step: the DC output will collapse below the adjusted value for a short time. t = transient time to settle the output voltage.

2.1.2 Current control / constant current / current limiting

Current control is also known as current limiting or constant current mode (short: CC).

The DC output current is held constant by the power supply, once the output current to the load reaches the adjusted limit. Then the power supply automatically switches to CC. The current flowing from the power supply is determined by the output voltage and the load's true resistance. As long as the output current is lower than the adjusted current limit, the device will be either in constant voltage or constant power mode. If, however, the power consumption reaches the adjusted power value, the device will switch automatically to power limiting and sets the output current according to $I_{MAX} = P_{SET} / U_{IN}$, even if the maximum current value is higher. The current set value, as determined by the user, is always an upper limit.

While the DC output is switched on and constant current mode is active, the condition "CC mode active" will be indicated on the graphic display with abbreviation **CC** and this message will be passed as a signal to the analog interface, as well stored as status which can also be read via digital interface.

2.1.2.1 Voltage overshootings

In certain situations it's possible that the device generates a voltage overshooting. Such situations are when the device is in CC, with the actual voltage being unregulated, and either a jump in the current set value is initiated which would bring the device out of CC or when the load is suddenly cut from the power supply by an external means. Peak and duration of the overshooting aren't exactly defined, but as rule of thumb it shouldn't exceed a peak of 1-2% of the rated voltage (on top of the voltage setting) while the duration mainly depends on the charging state of the capacities on the DC output and also the capacity value.

2.1.3 Power control / constant power / power limiting

Power control, also known as power limiting or constant power (short: CP), keeps the DC output power of a power supply constant if the current flowing to the load, in relation to the output voltage and the resistance of load, reaches the adjusted value according to $P = U \cdot I$ resp. $P = U^2 / R_{LOAD}$. The power limiting then regulates the output current according to $I = \sqrt{P / R}$, where R is the load's true resistance.

Power limiting operates according to the auto-range principle such that at lower output voltages higher current flows and vice versa in order to maintain constant power within the range P_N (see the diagram to the right).

While the DC output is switched on and constant power mode is active, the condition "CP mode active" will be shown on the graphic display by the abbreviation **CP**, as well stored as status which can also be read via digital interface.

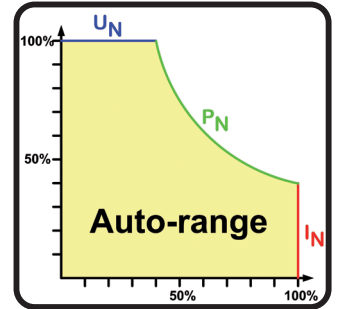

2.1.3.1 Power derating

Primarily, the models in this series are designed for 230 V AC supply, but can also operate on a supply with 120 V (USA). In order to limit the AC current when running on the low input voltage, the devices would automatically switch into a derating mode that reduces the available DC power, depending on the model. The model specific derated power is defined in technical specifications in the installation manual.

The switchover is determined once when the device is powered and it depends on the AC supply voltage being present in that moment. Should the voltage go up again later, the device would remain in derating mode as long as it's powered, because the switchover into and out of derating mode isn't dynamic. The full rated power is here only available with AC voltages from 220 V.

Once derated, the device would show a permanent information in the display and all values related to the power are reduced in their adjustment range. This also applies to master-slave operation of several units.

2.1.4 Internal resistance control

Internal resistance control (abbr. CR) of power supplies is the simulation of a virtual internal resistor which is in series to the load. According to Ohm's law, this resistance causes a voltage drop, which will result in a difference between adjusted output voltage and actual output voltage. This will work in constant current mode as well as in constant power mode, but here the output voltage will differ even more from the adjusted voltage, because then constant voltage is not active.

The available resistance range of a particular model is given in the technical specifications. The voltage control, in dependency of the resistance set value and the output current, is done by calculation in a microcontroller, being only a little slower than other controllers inside the main control circuit. Clarification:

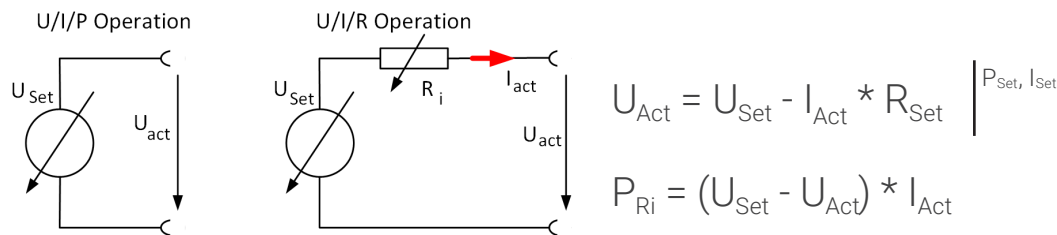

2.1.5 Actual value filter

From a certain set of firmwares, particularly HMI 4.05 and KE 3.08, the device supports a user-configurable filtering feature. Its purpose is to periodically smoothen the actual values as they are shown on the screen or put out as digital or analog values. The filtering, if activated, is working in a way that it reads an adjustable number of samples, i. e. measured actual values of voltage, current and power into an internal buffer, then calculates an average and exports the result as the next new set of actual values.

The user can select between modes **Fixed** and **Moving**, which differ as follows:

- **Fixed**: the selected number of samples is used to calculate the average, then the internal temporary sample buffer is purged and x new values are sampled
- **Moving**: the average is always calculated over the last x samples while the internal buffer isn't purged, but every new sample pushes all previous ones up so the values in the buffer move. This also means, that several subsequent average calculations are done with partially the same samples

Additionally to the mode, the user can select the size of the internal buffer (also called filtering stage) between 2 and 24. Together with the general fact that the device can deliver a new set of actual values every 20 ms, at least when the filtering is turned off, the filter delays every next new set of values by this factor. It means, with the highest setting of 24 new actual values are only put out on the interfaces and screen approximately every 480 ms.

2.1.6 Fast discharge

All models in this series are bidirectional and due to their built-in sink capability they can discharge their own output capacities and also those of a possibly connected, external source by sinking a high current, up to the rated one. This way of ramping the output voltage down quickly is only designed to work while the DC output remains switched on.

After switching it off, the main power stage would stop sinking energy, but a smaller, internal electronic load would take over and ensure to discharge the voltage in under 10 seconds to below 60 V, as part of a safety requirement. After reaching the threshold of 60 V, the voltage would continue to sink towards 0 V, but slower.

The feature **Fast discharge**, as available from firmwares KE 3.10 and HMI 4.09 for all 10000 power supply series, is a new functionality aiming to discharge the output voltage even quicker. It can be activated if needed (see section 2.2.1.7). Three adjustable parameters belong to it, the **Fast discharge voltage**, the **Fast discharge current** and the **Fast discharge duration**. The voltage value will determine to what level of voltage the fast discharge action is performed, together with the current, which has a primary impact. The device would, in the moment of the action, overwrite the currently adjusted set value of sink current by the fast discharge current and the one of the sink power to 102% P_{Rated} .

The actual duration of the discharge action also depends on the maximum current a particular device model can sink, as well as the model specific output capacity, and therefore isn't defined. The parameter of **Fast discharge time** allows to extend the duration wide enough for the feature to work correctly, as well as narrow it down to the necessary minimum. The maximum of 5 seconds is supposed to be enough to always discharge the output voltage even to 0 V, except a connected external source would prevent that.

As a side effect of the activated feature, the DC output status would remain as "on" as long as the discharge action runs after the user commanded to switch the DC output off manually by button On/Off or per remote control command, no matter what stop condition occurs first, the reached voltage threshold or the elapsed duration. It's expected that the output voltage would jump down to the adjusted threshold (**Fast discharge voltage**) in a split second, given the **Fast discharge current** is high enough, and, in case the threshold isn't set to 0 V, continue to sink, but as slow as when **Fast discharge** is deactivated.

Clarification:

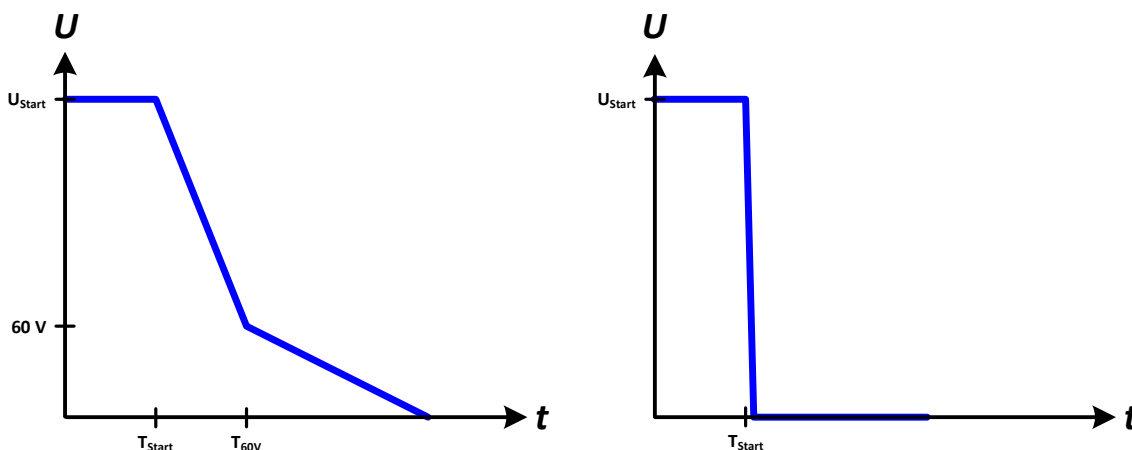

Figure 1 - Comparison of the voltage run after switching DC off without (left diagram) and with Fast discharge (to 0 V, right diagram) being activated



Since this a software feature, it won't work if the DC output is switched by other reasons, such as all alarms which would also switch DC off. That includes the moment when switching the device off.

2.1.7 STBY zero stabilization

This feature, as available from firmwares KE 3.10 and HMI 4.09 for all models of the 10000 series, is deactivated by default and be activated in the settings menu (see section 2.2.1.1), if needed. The goal is to stabilize the actual voltage value after the DC output has been switched off and after the voltage has sunken below a certain threshold (here: 3 V, model independent). The **STBY** in the name stand for stand-by and refers to the status of the DC output when switched off.

Due to technical reasons, the display actual voltage and the true voltage on the DC output can fluctuate and also remain slightly over 0 V. Those reasons are the switching power supply design, parasitic capacities and measurement errors. This feature, when activated, would set the actual voltage values to 0 V as long as the measured value on the DC output is below the threshold of 3 V. Since the device continuously measure the voltage on its DC output, also when DC is switched off, it would measure the voltage of a connected, external source as well. In both situations, voltage leaps between 3 V and 0 V in both directions are expected and normal. This suppresses the small voltage fluctuations around the zero point.

2.2 Manual operation (2)

2.2.1 Configuration via the menu

The settings menu is meant for the configuration of all operating parameters which are not constantly required. The menu is accessed by finger touch on the **Menu** touch area, but only while the DC output is switched off. See the figure to the right.

While the DC output is switched on the settings menu will not be shown, but some status information.

Menu navigation is also done by finger touch. Inside menus, all values are adjusted using the numeric pad that pops up when tapping a value.

Many settings are self-explanatory, others are not. Those will be explained on the following pages.

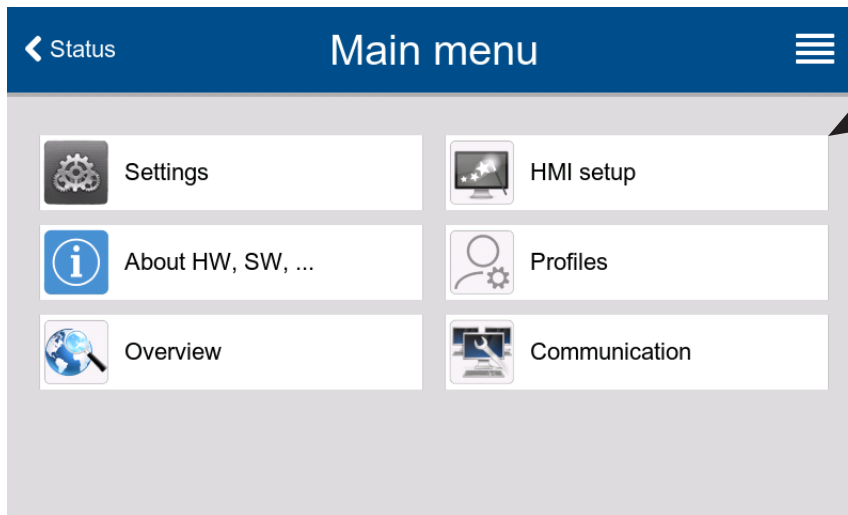
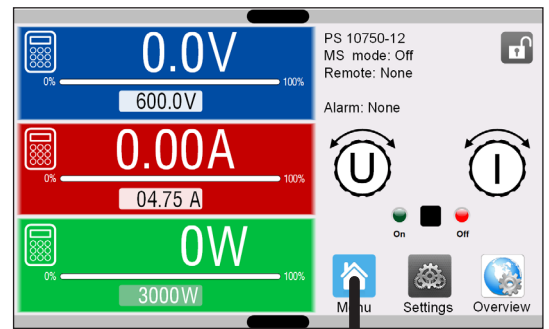

2.2.1.1 Sub menu “Settings”

Group	Parameters & description
Presets	U, I, P, R
	Presetting of all set values via on-screen numeric pad.
Protection	OVP, OCP, OPP
	Adjust the thresholds of the protections
Limits	U-max, U-min etc.
	Define the adjustment limits (find more information in «2.2.2 Adjustment limits»)
General	Allow remote control
	If remote control isn't allowed, the device cannot be controlled remotely over either the digital or analog interfaces. This situation will be shown as Local in the status area on the main display. Also see section 1.9.6.1 in the installation manual.
	Analog interface priority
	Activates or deactivates the priority of the analog interface regarding the action of taking over remote control by pin REMOTE. Find details in «2.3.4.8 Analog interface priority».
	R mode
	Activates or deactivates the internal resistance control. If activated, the set value and actual value of resistance will be shown on the main screen. For details refer to «2.1.4 Internal resistance control» in this document and «3.4.3. Manual adjustment of set values» in the installation manual.
	Voltage controller speed
	(Switching the speed only works if the device has already been <i>delivered</i> with firmware KE 3.02 and DR 1.0.2.20 or higher)
	This switch can be used to select the internal voltage controller speed which, as a result, impacts the voltage settling time. Also see «2.1.1.1 Voltage control peaks».
	<ul style="list-style-type: none"> • Slow = The voltage controller will be a little slower, the peaks will be lower, but wider • Normal = The voltage controller is on standard speed (Default) • Fast = The voltage controller will be a little faster, the peaks will be higher but narrower
	SEMI F47
	(Only displayed if the device has already been <i>delivered</i> with firmware KE 3.02 or higher)
	Activates or deactivates a feature called SEMI F47 which is related to the equally named standard. See «3.2 SEMI F47» for more information.
Actual value filter mode	
By selection of Fixed or Moving it activates a filter function for the actual values (voltage, current, power), as measured on the DC output of the device and shown on the HMI screen, as well as signaled on the analog and digital interfaces. For details refer to «2.1.5 Actual value filter».	
Actual value filter buffer size	
Belongs to Actual value filter mode , see above and «2.1.5 Actual value filter». Adjustable range: 2...24	
STBY zero stabilization	
Activates or deactivates the feature, as described in «2.1.7 STBY zero stabilization».	
Fast discharge	
Activates or deactivates the feature, as described in «2.1.6 Fast discharge».	
Fast discharge voltage	
Belongs to Fast discharge . Defines the threshold in Volts, to which the feature shall discharge the DC output voltage to. Range: 0V...102% U _{Nom}	

Group	Parameters & description
General	Fast discharge current
	Belongs to Fast discharge . Defines the maximum sink current in Amperes that is used to discharge the capacities on the DC output, in order to ramp the voltage down quicker. Range: 0A ...102% I _{Nom}
	Fast discharge duration
	Belongs to Fast discharge . Defines the maximum duration in milliseconds for the feature being active. Range: 0ms ...5000ms
Analog interface	Range
	Selects the voltage range for the analog set values, actual values and reference voltage output. <ul style="list-style-type: none"> • 0...5V = The range is 0...100% for set /actual values, reference voltage will be 5 V • 0...10V = The range is 0...100% for set /actual values, reference voltage will be 10 V Also see «2.3.4 Remote control via the analog interface»
	REM-SB Level
	Selects how the input pin REM-SB of the analog interface shall be working regarding levels (see «2.3.4.3 Analog interface specification») and logic: <ul style="list-style-type: none"> • Normal = Levels and function as described in the table in section 2.3.4.3 • Inverted = Levels and function will be inverted Also see «2.3.4.7 Application examples».
	REM-SB Action
	Selects how the input pin REM-SB of the analog interface shall operate regarding the DC output condition <u>outside</u> of analog remote control: <ul style="list-style-type: none"> • DC Off = The pin can only switch the DC output off • DC On/Off = The pin can switch the DC output off and on again, if it has been switched on before from a different control location
	Pin 6
	Pin 6 of the analog interface (see section 2.3.4.3) is by default assigned to signal both device alarms OT and PF. This parameter allows to also enable signaling only one of both (3 possible combinations): <ul style="list-style-type: none"> • Alarm OT = Pin 6 signals only alarm OT • Alarm PF = Pin 6 signals only alarm PF • Alarm PF + OT = Default, pin 6 signals either PF or OT
	Pin 14
	Pin 14 of the analog interface (see section 2.3.4.3) is by default assigned to only signal the device alarm OVP. This parameter allows to also enable signaling the device alarms OCP and OPP in 7 possible combinations: <ul style="list-style-type: none"> • Alarm OVP = Pin 14 signals only OVP • Alarm OCP = Pin 14 signals only OCP • Alarm OPP = Pin 14 signals only OPP • Alarm OVP+OCP = Pin 14 signals OVP or OCP • Alarm OVP+OPP = Pin 14 signals OVP or OPP • Alarm OCP+OPP = Pin 14 signals OCP or OPP • Alarm OVP+OCP+OPP = Pin 14 signals any of the three alarms
Pin 15	
Pin 15 of the analog interface (see section 2.3.4.3) is by default assigned to signal the control mode CV. Alternatively, it allows to signal the DC output status: <ul style="list-style-type: none"> • Regulation mode = Signals the CV control mode • DC status = Signals the DC output status 	

Group	Parameters & description
DC output	State after power ON
	<p>Determines the condition of the DC output after power-up.</p> <ul style="list-style-type: none"> • Off = The DC output is always off after switching on the device • Restore = The DC output state will be restored from the last switch-off <div style="border: 1px solid black; padding: 5px; margin-top: 10px;">  <p>The factory default of this setting, also after a device reset, is "Off". Setting this to "Restore" solely lies within the responsibility of the operator, as the device could automatically start to supply voltage after boot-up, depending on the restored state of the DC output. Be careful!</p> </div>
	State after PF alarm
	<p>Determines the condition of the DC output after a power fail (PF) alarm:</p> <ul style="list-style-type: none"> • Off = The DC output remains off • Auto = The DC output will switch on again after the PF alarm cause is gone, if it has been switched on before the alarm occurred
	State after remote
Master-slave	<p>Determines the condition of the DC output after leaving remote control either manually or by command:</p> <ul style="list-style-type: none"> • Off = The DC output will always be off after leaving remote control • Auto = The DC output will keep the last state
	State after OT alarm
	<p>Determines the condition of the DC output after an overtemperature (OT) alarm, once the device has cooled down:</p> <ul style="list-style-type: none"> • Off = The DC output will remain off • Auto = The device will automatically restore the situation before the OT alarm, which usually means the DC output to be on
	Mode
	<p>Selecting Master or Slave enables the master-slave mode (MS) and defines the position for the unit in the MS system. For details see «3.1 Parallel operation in master-slave (MS)».</p>
	Termination resistor
	<p>Activates or deactivates the so-called bus termination of the digital master-slave bus via a switchable resistor. Termination should be activation if required, usually when problems with the master-slave bus operation occur.</p>
Bias resistors	
<p>Additionally to the regular termination resistor (TERM) this activates two bias resistor, if required, to help stabilize the bus further. Tap on the information symbol for a graphical depiction.</p>	
Backlight off after 60s	
<p>If activated, it will switch off the display's backlight after 60 seconds of inactivity. This settings is primarily intended for slave units where the display isn't supposed to be permanently on. It's identical to the setting in menu HMI setup.</p>	
Initialize system	
<p>Tapping this touch area will repeat the initialization of the master-slave system in case the detection of all slave units by the master was unsuccessful, so the system would have less total power than expected, or has to be repeated manually in case the master unit couldn't detect a missing slave or one slave has failed.</p>	

Group	Parameters & description
USB logging	Log file separator format
	Defines the format of CSV files generated from logging files (also see section 2.2.4 in this document, as well as section 1.9.6.5 in the installation manual). This setting also affects other features where a CSV file can be loaded or saved. <ul style="list-style-type: none"> • US = Comma as column separator (US standard for CSV files) • Default = Semicolon as column separator (german/european standard for CSV files)
	Logging with units (V,A,W)
	CSV files generated from USB logging by default add physical units to values. This can be deactivated here.
	USB logging
	Activates/deactivates logging to USB stick. For more information refer to «2.2.4 Recording to USB stick (logging)».
	Logging interval
	Defines the time between two records in the log file. Selection: 500ms, 1s, 2s, 5s
Reset / Restart	Start/stop
	Defines how the USB logging is started and stopped. <ul style="list-style-type: none"> • Manual = The logging only starts and stops upon user interaction on the HMI, by accessing touch button  in the quick menu. • At DC on/off = The logging starts and stops with every change of state on the DC output, no matter if caused by the user, software or a device alarm. Attention: Every next start will create a new log file.
	Reset device to defaults
	This touch area will initiate a reset of most settings (HMI, profile etc.) to factory default.
	Restart
	Triggers a warm start

2.2.1.2 Sub menu “Profiles”

See «2.2.6 Loading and saving user profiles».

2.2.1.3 Sub menu “Overview”

This menu page displays an overview of the set values (U, I, P or U, I, P, R), device alarm thresholds, adjustment limits, as well as an alarm history which lists the number of device alarms that occurred since the device has been powered.

2.2.1.4 Sub menu “About HW, SW...”

This menu page displays an overview of device relevant data such as serial number, article number etc.

2.2.1.5 Sub menu “Communication”

This sub menu offers settings for digital communication via the built-in interfaces USB and Ethernet and also for the optional interface modules of IF-AB series.

There is furthermore an adjustable communication timeout for USB or RS232, to make it possible to successfully transfer fragmented messages (data packets) using higher values. In group **Protocols** you can disable one of the two supported communication protocols, ModBus and SCPI. This can help to avoid mixing both protocols and to receive unreadable messages, for example when expecting an SCPI response and getting a ModBus response instead. The USB itself doesn't require any settings.

The device will have following default Ethernet port related settings which are listed in group **Ethernet (internal)**:

IF	Settings	Description
Ethernet (internal)	DHCP	The IF allows a DHCP server to allocate an IP address, a subnet mask and a gateway. If no DHCP server is in the network then network parameters will be set as defined below.
	IP address	Manually allocate an IP address.
	Subnet mask	Manually allocate a subnet mask.
	Gateway	Manually allocate a gateway address, if required.
	DNS address	Manually allocate addresses of a Domain Name Server (DNS), if required.
	Port	Select port in the range 0...65535. Default port: 5025 Reserved ports: 502 (ModBus TCP), 537
	Host name	User definable host name
	Domain	User definable domain

Settings for the optional interface modules (IF-AB-xxx)

IF	Settings	Description
Profibus	Node Address	Selection of the Profibus or node address of the device within range 1...125 via direct input
	Function Tag	String input box for a user-definable text which describes the Profibus slave function tag. Max. length: 32 characters
	Location Tag	String input box for a user-definable text which describes the Profibus slave location tag. Max. length: 22 characters
	Installation Date	String input box for a user-definable text which describes the Profibus slave installation date tag. Max. length: 40 characters
	Description	String input box for a user-definable text which describes the Profibus slave. Max. length: 54 characters
	Manufacturer ID	Registered manufacturer ID with the Profibus organization
	Ident number	Product identification number, same as in the GSD file

IF	Settings	Description
Slot Ethernet, ModBus-TCP (1 & 2 Port)	DHCP	The IF allows a DHCP server to allocate an IP address, a subnet mask and a gateway. If no DHCP server is in the network then network parameters will be set as defined below.
	IP address	This option is activated by default. An IP address can be manually allocated.
	Subnet mask	Here a subnet mask can be defined if the default subnet mask is not suitable.
	Gateway	Here a gateway address can be allocated if required..
	DNS address	Here the addresses of the first and second Domain Name Servers (DNS) can be defined, if needed.
	Port	Select port in the range 0...65535. Default port: 5025 Reserved ports: 502 (ModBus TCP), 537
	Host name	User definable host name (default: Client)
	Domain	User definable domain (default: Workgroup)
	Speed / Duplex Port 1	Manual selection of transmission speed (10MBit/100MBit) and duplex mode (full/half). It's recommended to use the Auto option and only revert to another option if Auto fails.
	Speed / Duplex Port 2	Different Ethernet port settings for 2-port modules are possible, as these include an Ethernet switch

IF	Settings	Description
Profinet/IO (1 & 2 Port)	Host name	Free choice of host name (default: Client)
	Domain name	Free choice of Domain (default: Workgroup)
	Function Tag	String input box for a user-definable text which describes the Profinet slave function tag. Max. length: 32 characters
	Location Tag	String input box for a user-definable text which describes the Profinet slave location tag. Max. length: 22 characters
	Installation Date	String input box for a user-definable text which describes the Profibus slave installation date tag. Max. length: 40 characters
	Description	String input box for a user-definable text which describes the Profibus slave. Max. length: 54 characters
	Station Name	String input box for a user-definable text which describes the Profinet station name. Max. length: 200 characters

IF	Settings	Description
RS232	Baud rate	The baud rate is selectable, other serial settings can't be changed and are defined like this: 8 data bits, 1 stop bit, parity = none Baud rates: 2400Bd, 4800Bd, 9600Bd, 19200Bd, 38400Bd, 57600Bd, 115200Bd

IF	Settings	Description
CAN	Baud rate	Setup of the CAN bus speed or baud rate in typical value between 10 kbps and 1Mbps. Default: 500 kbps
	ID Format	Selection of the CAN ID format and range between Standard (11 Bit ID, 0h...7ffh) and Extended (29 Bit, 0h...1fffffffh)
	Termination	Activates or deactivates CAN bus termination with a built-in resistor. Default: off
	Data length	Determines the DLC (data length) of all messages sent from the device. Auto = length can vary between 3 and 8 bytes Always 8 Bytes = length is always 8, filled up with zeros
	Base ID	Setup of the CAN base ID (11 Bit or 29 Bit, hex format). Default: 0h
	Broadcast ID	Setup of the CAN broadcast ID (11 Bit or 29 Bit, hex format). Default: 7ffh
	Base ID Cyclic Read	Setup of the CAN base ID (11 Bit or 29 Bit, hex format) for cyclic read of several object groups. The device will automatically send object data to the IDs defined with this setting. For more information refer to the programming guide. Default: 100h
	Base ID Cyclic Send	Setup of the CAN base ID (11 Bit or 29 Bit, hex format) for cyclic send of set values along with status. For more information refer to the programming guide. Default: 200h
	Cyclic Read Time: Status	Activation/deactivation and time setting for the cyclic read of status from the adjusted Base ID Cyclic Read . Range: 20...5000 ms. Default: 0ms (deactivated)
	Cyclic Read Time: Set values	Activation/deactivation and time setting for the cyclic read of set values of U & I from the adjusted Base ID Cyclic Read + 2 . Range: 20...5000 ms. Default: 0ms (deactivated)
	Cyclic Read Time: Limit values 1	Activation/deactivation and time setting for the cyclic read of adjustment limits of U & I from the adjusted Base ID Cyclic Read + 3 . Range: 20...5000 ms. Default: 0ms (deactivated)
	Cyclic Read Time: Limit values 2	Activation/deactivation and time setting for the cyclic read of adjustment limits of P & R to the adjusted Base ID Cyclic Read + 4 . Range: 20...5000 ms. Default: 0ms (deactivated)
	Cyclic Read Time: Actual values	Activation/deactivation and time setting for the cyclic read of actual values from the adjusted Base ID Cyclic Read + 1 . Range: 20...5000 ms. Default: 0ms (deactivated)
Module firmware	CAN module firmware version	

IF	Settings	Description
CANopen	Baud Rate	CAN bus baud rate selection that is used by the CANopen interface. Auto = Automatic detection LSS = Baud rate and node address are assigned by the bus master Fixed baud rates: 10kbps, 20kbps, 50kbps, 100kbps, 125kbps, 250kbps, 500kbps, 800kbps, 1Mbps
	Node Address	Selection of the CANopen node address in the range 1...127

Further communication related parameters

Group	Parameters & description
Timeouts	TCP keep-alive (internal) / TCP keep-alive (slot)
	Activates the keep-alive network functionality for the Ethernet port, which is used to keep the socket connection open. As long as keep-alive is present in the network, the device will disable the Ethernet timeout. Also see below at Timeout ETH .
	Timeout USB/RS232
	Defines the max. time between two subsequent bytes or blocks of a transferred message. For more information about the timeout refer to the external programming documentation "Programming Guide ModBus & SCPI". Default value: 5ms , Range: 5 ms...65535 ms
	Timeout ETH (internal) / Timeout ETH (slot)
	Defines a timeout after which the device would close the socket connection if there was no command communication between the controlling unit (PC, PLC etc.) and the device for the adjusted time. The timeout is ineffective as long as option TCP keep-alive is enabled for the particular interface and the keep-alive network service is running. A setting of 0 would deactivate the timeout permanently. Default value: 5s , Range: 0 / 1 s...65535 s (0 = timeout deactivated)
Protocols	Interface monitoring / Timeout Interface monitoring
	Activates/deactivates the interface monitoring (see «2.3.3.3 Interface monitoring»). Default values: off, 5s / Range: 1 s...65535 s
	Communication protocols
	Enables or disables SCPI or ModBus communication protocols for the device. The change is immediately effective. Only one of both can be disabled.
Protocols	ModBus specification compliance
	Allows to switch from Limited (default setting) to Full which makes the device send messages in ModBus RTU or ModBus TCP format which fully comply to the specification and are compatible to softwares available on the market. With Limited the device would still use the old, partially wrong message format (see the separate programming guide for details).

2.2.1.6 Menu “HMI Setup”

These settings refer exclusively to the control panel (HMI).

Group	Parameters & description
Language	Selection of the display language (default: English)
Sound	Key sound
	Activates or deactivates sounds when touching a touch area in the display. It can usefully signal that the action has been accepted.
Sound	Alarm sound
	Activates or deactivates the additional acoustic signal of an alarm. See also «3.5. Alarm and monitoring» in the installation manual.
Clock	Internal clock and date setup
Backlight	Backlight off after 60s
	The choice here is whether the backlight remains permanently on (default) or if it should go off after 60 s, if there was no input via touch screen or knob. As soon as there is input, the backlight returns automatically. Furthermore, the backlight intensity can be adjusted here.
Lock	See «3.4.5 Locking the control panel (HMI)» and «3.4.6 Locking the adjustment limits and user profiles» in the installation manual

2.2.2 Adjustment limits



Adjustment limits are only effective on the related set values, no matter if using manual adjustment or remote control setting!



Default is that all set values (U, I, P, R) are adjustable from 0 to 102%.

The full range may be obstructive in some cases, especially for protection of applications against overvoltage. Therefore upper and lower limits for current (I) and voltage (U) can be set separately, which then limit the range of the adjustable set values.

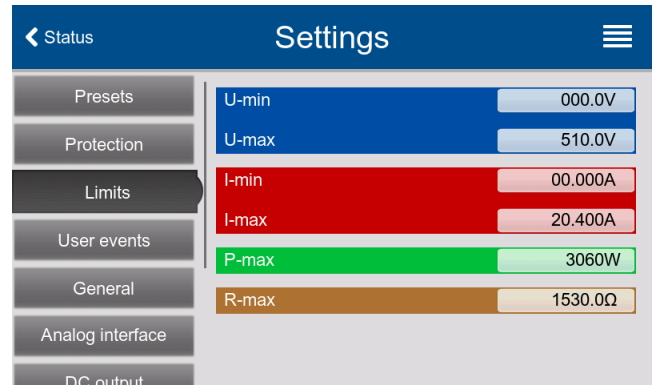
For power (P) and resistance (R) only upper value limits can be set.



► How to configure the adjustment limits

1. While the DC output is switched off, tap  on the main screen.
2. Tap on group **Limits** on the left side to open the list of limits. They are grouped and colored for distinction. Values are adjusted by tapping on them, in a window popping up with a numeric pad. Values further down in the list are accessed by swiping the list up.
3. Adjust the desired value and submit with .



The adjustment limits are coupled to the set values. It means, that the upper limit may not be set lower than the corresponding set value. Example: If you wish to set the limit for the power set value (P-max) to 2500 W while the currently adjusted power set value is 3000 W, then the set value would first have to be reduced to 2500 W or less, in order to set P-max down to 2500 W.

2.2.3 Changing the operating mode

In general, the manual operation of the device distinguishes between three operating modes: U/I, U/P and U/R. They are tied to set value input using the rotary knobs or the on-screen numeric pad. The current assignment can be switched anytime if you want to adjust a set value which is currently not assigned to any of the knobs.

► How to change the operating mode (two options)

1. Unless the device is in remote control or the panel is locked, you can switch the operation anytime. Tap on the depiction of the right-hand knob (see the figure to the right) to change its assignment between I, P and R (if resistance mode is enabled), which is then displayed accordingly.
2. Directly tap on the colored areas with the set values, as shown in the figure to the right. The physical unit next to the set value, when inverted, indicates the assignment to the knob.

Depending on the selection, the right rotary knob will be assigned different setting values, the left knob is always assigned to the voltage.



In order to change the other values, like P or R while U/I is active, and without switching the assignment all the time, direct input can be used.

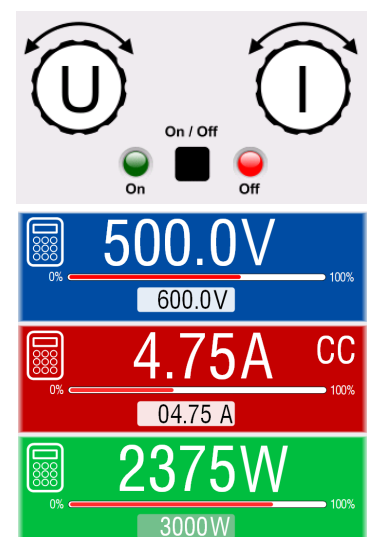

The actual operating mode, which is only indicated while the DC output is switched on, solely depends on the set values. For more information see «2.1 Operating modes».

2.2.4 Recording to USB stick (logging)

Device data can be recorded to USB stick (USB 3.0 is supported, but not all memory sizes) anytime. For specifications of the USB stick and the generated log files refer to section «1.9.6.5. USB port (front side)» in the installation manual.

The logging stores files of CSV format on the stick where the layout of the log data is the same as when logging via PC with software EA Power Control. The advantage of USB logging over PC logging is the mobility and that no PC is required. The logging feature just has to be activated and configured in the Settings.

2.2.4.1 Configuration



Also see section 2.2.1.5. After USB logging has been enabled and the parameters **Logging interval** and **Start/Stop** have been set, logging can be started anytime from within the Settings menu or when switching the DC output on, all depending on the selected start/stop mode.

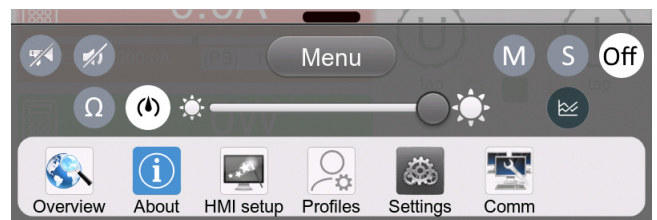

Furthermore see section 2.2.1.1. There are additional settings for the CSV file itself as generated by the USB logging features. You can switch the column separator format between german/european standard (**Default**) or US american standard (**US**). The other option is used to deactivate the physical unit that is added by default to every set/actual value in the log file. Deactivating this option simplifies the CSV file processing in MS Excel or similar tools.

2.2.4.2 Handling (start/stop)

With setting **Start/stop** to **At DC on/off** logging will start each time the DC output of the device is switched on, no matter if manually with the front button **On/Off** or remotely via analog or digital interface. With setting **Manual** it's different. Logging is then started and stopped only in the quick menu (see the figure to the right).



Button  starts logging manually and changed to , which is for manual stop.

Soon after logging has been started, the symbol  indicates the ongoing logging action. In case there is an error while logging, such as the USB stick is full or removed, it will be indicated by another symbol . After every manual stop or switching the DC output off the logging is stopped and the log file closed.

2.2.4.3 USB logging file format

Type: text file in german/european or US american CSV format (depending on the selected setting)

Layout (default german format shown):

	A	B	C	D	E	F	G	H	I	J	K	L	M
1	U set	U actual	I set	I actual	P set	P actual	R set	R actual	R mode	Output/Input	Device mode	Error	Time
2	2,00V	11,92V	1,20A	1,20A	7344W	15W	N/A	N/A	OFF	ON	CC	NONE	00:00:00,942
3	2,00V	11,90V	1,20A	1,20A	7344W	15W	N/A	N/A	OFF	ON	CC	NONE	00:00:01,942
4	2,00V	11,89V	1,20A	1,20A	7344W	15W	N/A	N/A	OFF	ON	CC	NONE	00:00:02,942
5	2,00V	11,87V	1,20A	1,20A	7344W	15W	N/A	N/A	OFF	ON	CC	NONE	00:00:03,942

Legend:

U set / I set / P set / R set: Set values U, I, P and R

U actual / I actual / P actual / R actual: Actual values

R mode: Resistance mode activated/deactivated (also called 'UIR mode')

Output/Input: State of the DC output

Device mode: Actual control mode (also see «2.1 Operating modes»)

Error: Device alarms

Time: Elapsed time since logging start

Important to know:

- R set and R actual are only recorded if UIR mode is active (refer to section 2.2.3)
- Unlike the logging on PC, every log start here creates a new log file with a counter in the file name, starting generally with 1, but minding existing files

2.2.4.4 Special notes and limitations

- Max. log file size (due to FAT32 formatting): 4 GB
- Max. number of log files in folder HMI_FILES: 1024
- With setting **Start/stop** being **At DC on/off**, the logging will also stop on alarms, because they switch off the DC output
- With setting **Start/stop** being **Manual**, the device will continue to log even on occurring alarms, so this mode can be used to determine the period of temporary alarms like OT or PF

2.2.5 The quick menu

The device offers a quick menu which allows for the quick access to often used features and modes being switched on or off in the **Settings** menu. It can be opened by swiping up from the bottom screen edge or tapping the bar:

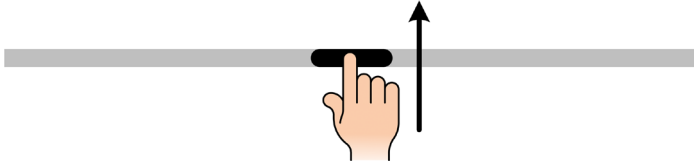

Overview:



Tapping a button activates or deactivates a feature. Buttons with black on white indicate an activated feature:

Symbol	Belongs to	Meaning or function
	USB logging	USB logging is running (the symbol is only available when USB logging has been activated in menu Settings)
	Master-slave	Master-slave activated, device is master
	Master-slave	Master-slave activated, device is slave
	Master-slave	Master-slave deactivated
	Resistance mode	R mode = on
	HMI	Alarm sound = on
	HMI	Key sound = on
	HMI	Opens the graph screen
	Operation modes	Switches voltage controller speed between Slow , Normal (default) and Fast (see section 2.1.1.1)
	HMI	Adjust backlight intensity
	HMI	Opens the main menu

2.2.6 Loading and saving user profiles

The menu Profiles serves to select between a default profile and up to 5 user profiles. A profile is a collection of all settings and set values. Upon delivery or after a factory reset, all 6 profiles have the same settings and all set values are 0. Values adjusted on the main screen or anywhere else belong to a working profile which can be saved to one of the 5 user profiles. These user profiles or the default profile can then be switched. The default profile is read-only.

The purpose of a profile is to load a set of set values, settings limits and monitoring thresholds quickly without having to readjust these. As all HMI settings are saved in the profile, including language, a profile change can also be accompanied by a change in HMI language.

On calling up the menu page and selecting a profile the most important settings can be seen, but not changed.

► How to save the current values and settings as a user profile

1. While the DC output is switched off, tap on touch area  on the main screen.
2. In the main menu tap on **Profiles**.
3. In the next screen (see the example to the right) choose between user profiles 1-5, which will show the profile's stored settings for your verification.
4. Tap on **Save/Load** and save the settings into the user profile in the coming up requester **Save profile?** with **Save**.

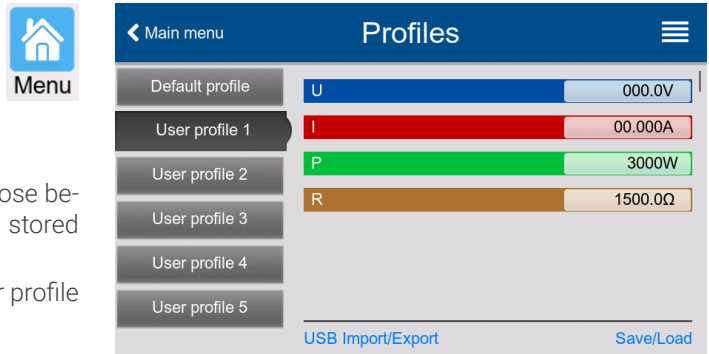

All user profiles also allow to just edit some settings or values stored in the profile. When doing so, the changes either need to be saved to the profile with "Save changes" or discarded with "Cancel" before the profile can be loaded.

Loading a user profile works the same way, but in the requester you would then tap **Load** under **Load profile?**. Alternatively, you may import the profile or export it as file to a USB stick with **USB Import/Export**.

► How to edit a user profile

1. While the DC output is switched off, tap on touch area  on the main screen.
2. In the main menu tap on **Profiles**.
3. In the next screen choose the user profile to edit, which will show the profile's stored settings for your verification.
4. Tap on the values you want to edit. As soon as any values has been changed, the button **Save/Load** will turn into **Save changes**.
5. Tap on **Save changes** to save the changes into the user profile. At this point, the profile's values are not effective yet.
6. Optional: in order to submit the changes in the user profile to the working profile, tap on **Save/Load** and in the requester **Load profile?** choose **Load**.

2.2.7 The graph

From HMI firmware version 2.02 the devices feature a manually callable, HMI operated visual depiction of the temporal run of the actual values of voltage, current and power, called the graph. However, it isn't a recording feature. For data recording in the background there is the USB logging option (see section 2.2.4).

The graph can be called up anytime via the quick menu. When shown, it completely fills the screen.



Limited control options available while the graph is shown on screen! For safety reasons, however, it's possible to switch off the DC output anytime via the On/Off button.

Overview:

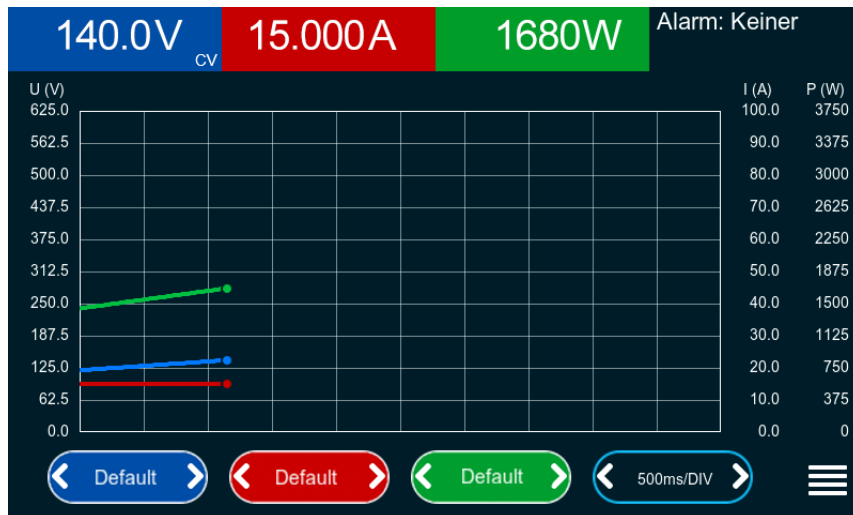

Controls:

- Tapping the **middle** of the three red/green/blue touch areas deactivates/activate the corresponding plot
- Tapping the **sides** (arrows left/right) of the red/green/blue touch areas increases/decreases the vertical scaling
- Tapping the **sides** (arrows left/right) of the black touch area increases/decreases the horizontal scaling
- Swiping on the three scales (Y axis) moves them up or down
- Tapping the menu touch area (☰) exits the graph screen anytime

2.3 Remote control

2.3.1 General

Remote control is possible via one of the built-in interfaces (analog, USB, Ethernet) or via one of the optional interface modules. Important here is that only the analog or any of the digital interfaces can be in control. One of them is the master-slave bus.

Important here is that only the analog or any digital interface can be in control. It means that if an attempt was made to switch to remote control via the digital interface whilst analog remote control is active (pin REMOTE = LOW) the device would report an error via the digital interface. In the opposite direction, a switch-over via pin REMOTE would be ignored. However, status monitoring and reading of values are always possible.

2.3.2 Control locations

Control locations are those locations from where the device can be controlled. Essentially there are two: at the device (manual operation) and external (remote control). The following locations are defined:

Displayed location	Description
Remote: None	If neither of the other locations is displayed then manual control is active and access from the analog and digital interfaces is allowed.
Remote: <interface_name>	Remote control via any interface is active
Local	Remote control is locked, only manual operation is allowed.

Remote control may be allowed or inhibited using the setting **Allow remote control** (see «2.2.1.1 Sub menu "Settings"»). In inhibited condition the status **Local** will be displayed top right. Activating the inhibit can be useful if the device is remotely controlled by software or some electronic device, but it's required to make adjustments on the device or to deal with an emergency.

Activating condition **Local** causes the following:

- If remote control via the digital interface is active (e. g. **Remote: USB**), then it's immediately terminated and in order to continue remote control once **Local** is no longer active, it has to be reactivated at the PC
- If remote control via the analog interface is active (**Remote: Analog**), then it's temporarily interrupted until remote control is allowed again by deactivating **Local**, because pin REMOTE continues to signal "remote control = on", unless this has been changed during the **Local** period.

2.3.3 Remote control via a digital interface

2.3.3.1 Selecting an interface

In addition to the built-in USB and Ethernet ports, all models of this series support the following optionally available interface modules:

Short ID	Type	Ports	Description*
IF-AB-CANO	CANopen	1	CANopen slave with generic EDS
IF-AB-RS232	RS232	1	Standard RS232, serial
IF-AB-PBUS	Profibus	1	Profibus DP-V1 slave
IF-AB-PNET1P	ProfiNet	1	Profinet DP-V1 slave
IF-AB-PNET2P	ProfiNet	2	Profinet DP-V1 slave, with switch
IF-AB-CAN	CAN	1	CAN 2.0 A / 2.0 B
IF-AB-ECT	EtherCAT	2	Basic EtherCAT slave with CANopen over Ethernet (CoE)
IF-AB-MBUS	ModBus TCP	1	ModBus TCP protocol via Ethernet
IF-AB-MBUS2P	ModBus TCP	2	ModBus TCP protocol via Ethernet

* For technical details of the various modules see the extra documentation "Programming Guide Modbus & SCPI"

2.3.3.2 Programming

Programming details for the interfaces, the communication protocols etc. are to be found in the documentation "Programming Guide Modbus & SCPI" which is supplied on the included USB stick or which is available as download from the manufacturer's website.

2.3.3.3 Interface monitoring

Interface monitoring is a configurable functionality introduced in firmwares KE 2.06 and HMI 2.08. Its goal is to monitor (or supervise) the digital communication line between the device and a superior control unit, such as PC or PLC, and to ensure that the device wouldn't continue working uncontrolled in case the communication line fails. A failing line can mean that it's either physically interrupted (damaged cable, bad contact, cable pulled) or the interface port inside the device hangs.

The monitoring is always only valid for one of the digital interfaces, the one being used for remote control. It thus means that the monitoring can become temporarily inactive when the device leaves remote control. It's furthermore based on a user-definable timeout which would run out if not at least one message is sent to the device within the given time frame. After every message, the timeout would start again and reset with the next incoming message. In case it runs out, the following reaction of the device is defined:

- Exit remote control
- In case the DC output is switched on, it either switches it off or leaves it on, as defined by the parameter **DC output -> State after remote** (see section 2.2.1.7)

Notes for the operation:

- The timeout of the monitoring can be changed anytime via remote control; the new value would only be valid after the current timeout has elapsed
- The interface monitoring doesn't deactivate the Ethernet connection timeout (see section 2.2.1.5), so these two timeouts can overlap

2.3.4 Remote control via the analog interface

2.3.4.1 General

The built-in, galvanically isolated, 15-pole analog interface (below referenced in short form as **AI**) is located on the rear side of the device and provides the following possibilities:

- Remote control of current, voltage, power and internal resistance
- Remote status monitoring (CC/CP, CV, DC output)
- Remote alarm monitoring (OT, OVP, OCP, OPP, PF)
- Remote monitoring of actual values
- Remote on/off switching of the DC output

Setting the set values of voltage, current and power via the analog interface must always be done concurrently. It means, that for example the voltage can't be given via the AI and current and power set by the rotary knobs, or vice versa. The internal resistance set value can additionally be adjusted.

The OVP set value and other alarm thresholds can't be set via the AI and therefore must be adapted to the given situation before the AI is taking over control. Analog set values can be supplied from an external voltage source or can be derived from the reference voltage on pin 3. As soon as remote control via the analog interface is activated, the set values on the display will be those supplied to the interface.

The AI can be operated in the common voltage ranges 0...5 V and 0...10 V, both representing 0...100% of the rated value. The selection of the voltage range can be done in the device setup. See «2.2.1 Configuration via the menu» for details. The reference voltage sent out from pin 3 (VREF) will be adapted accordingly:

0-5V: Reference voltage = 5 V, 0...5 V set value signal for VSEL, CSEL, PSEL and RSEL correspond to 0...100% nominal value, 0...100% actual values correspond to 0...5 V at the actual value outputs CMON and VMON.

0-10V: Reference voltage = 10 V, 0...10 V set value signal for VSEL, CSEL, PSEL and RSEL correspond to 0...100% nominal values, 0...100% actual values correspond to 0...10 V at the actual value outputs CMON and VMON.

All set values are always additionally limited to the corresponding adjustment limits (U-max, I-max etc.), which would clip setting excess values for the DC output. Also see «2.2.2 Adjustment limits».

Before you begin, please read these important notes about the use of the interface:



After powering the device and during the start phase the AI signals undefined statuses on the output pins. Those must be ignored until is ready to work.

- Analog remote control of the device must be activated by switching pin REMOTE (5) first. Only exception is pin REM-SB, which can be used independently
- Before the hardware is connected that will control the analog interface, it shall be checked that it can't provide voltage to the pins higher than specified (see the table in section 2.3.4.3)
- Set value inputs, such as VSEL, CSEL, PSEL and RSEL, if R mode is activated, must not be left unconnected (i.e. floating) during analog remote control. In case any of the set values isn't used for adjustment, it can be tied to a defined level or connected to pin VREF (solder bridge or different)

2.3.4.2 Acknowledging device alarms

In case of a device alarm occurring during remote control via analog interface, the DC output will be switched off the same way as in manual control. The device would indicate an alarm (see section 3.5 in the installation manual) in the front display and, if activated, acoustically and also signal most of them on the analog interface. Which alarms are eventually signaled can be set up in the device configuration menu (see «2.2.1.1 Sub menu "Settings"»).

The alarms MSP, OVP, OCP and OPP have to be acknowledged (also see «3.5.2 Device alarm and event handling» in the installation manual). Acknowledgment is done with pin REM-SB switching the DC output off and on again, that means a HIGH-LOW-HIGH edge (min. 50ms for LOW), given the default logical level is set for REM-SB.

The same is required for PF and OT in case the related settings **State after PF alarm** or **State after OT alarm** in settings menu group **DC output** are set to **Off**.

There is one **exception**: the SOVP (Safety OVP) alarm, which is only featured with the 60 V model of this series. It can't be acknowledged and requires to power-cycle the device. It can be monitored via the analog interface and would be indicated by the alarms PF and OVP being signaled at the same time, so it would require to select the alarm indication on pin 6 to at least signal PF and for pin 14 to signal OVP in any of the combinations.

2.3.4.3 Analog interface specification

Pin	Name	Type ⁽¹⁾	Description	Default levels	Electrical specifications
1	VSEL	AI	Set voltage value	0...10 V or. 0...5 V correspond to 0..100% of U_{Nom}	Accuracy 0-5 V range: < 0.4% ⁽⁵⁾ Accuracy 0-10 V range: < 0.2% ⁽⁵⁾
2	CSEL	AI	Set current value	0...10 V or. 0...5 V correspond to 0..100% of I_{Nom}	Input impedance R_i >40 k...100 k
3	VREF	AO	Reference voltage	10 V or 5 V	Tolerance < 0.2% at $I_{Max} = +5$ mA Short-circuit-proof against AGND
4	DGND	POT	Digital ground		For control and status signals
5	REMOTE	DI	Switches between manual and remote control	Remote = LOW, $U_{Low} < 1$ V Manual = HIGH, $U_{High} > 4$ V Manual, if pin not wired	Voltage range = 0...30 V $I_{Max} = -1$ mA at 5 V U_{Low to HIGH typ. = 3 V Rec'd sender: Open collector against DGND
6	ALARMS 1	DO	Overheating or power fail alarm	Alarm = HIGH, $U_{High} > 4$ V No alarm = LOW, $U_{Low} < 1$ V	Quasi open collector with pull-up against V_{cc} ⁽²⁾ With 5 V on the pin max. flow +1 mA $I_{Max} = -10$ mA at $U_{CE} = 0,3$ V $U_{Max} = 30$ V Short-circuit-proof against DGND
7	RSEL	AI	Set internal resistance value	0...10 V or. 0...5 V correspond to 0..100% of R_{Max}	Accuracy 0-5 V range: < 0.4% ⁽⁵⁾ Accuracy 0-10 V range: < 0.2% ⁽⁵⁾
8	PSEL	AI	Set power value	0...10 V or. 0...5 V correspond to 0..100% of P_{Nom}	Input impedance R_i >40 k...100 k
9	VMON	AO	Actual voltage	0...10 V or. 0...5 V correspond to 0..100% of U_{Nom}	Accuracy 0-5 V range: < 0.4% ⁽⁵⁾ Accuracy 0-10 V range: < 0.2% ⁽⁵⁾
10	CMON	AO	Actual current	0...10 V or. 0...5 V correspond to 0..100% of I_{Nom}	at $I_{Max} = +2$ mA Short-circuit-proof against AGND
11	AGND	POT	Analog ground		For xSEL, xMON and VREF
12	R-ACTIVE	DI	R mode on / off	On = LOW, $U_{Low} < 1$ V Off = HIGH, $U_{High} > 4$ V Off, if pin not wired	Voltage range = 0...30 V $I_{Max} = -1$ mA bei 5 V U_{Low to HIGH typ. = 3 V Rec'd sender: Open collector against DGND
13	REM-SB	DI	DC output OFF (DC output ON) (ACK alarms ⁽⁴⁾)	Off = LOW, $U_{Low} < 1$ V On = HIGH, $U_{High} > 4$ V On, if pin not wired	Voltage range = 0...30 V $I_{Max} = +1$ mA at 5 V Rec'd sender: Open collector against DGND
14	ALARMS 2	DO	Overvoltage alarm Overcurrent alarm Overpower alarm	Alarm = HIGH, $U_{High} > 4$ V No alarm = LOW, $U_{Low} < 1$ V	Quasi open collector with pull-up against V_{cc} ⁽²⁾ With 5 V on the pin max. flow +1 mA $I_{Max} = -10$ mA at $U_{CE} = 0,3$ V, $U_{Max} = 30$ V Short-circuit-proof against DGND
15	STATUS ⁽³⁾	DO	Constant voltage control active DC output	CV = LOW, $U_{Low} < 1$ V CC/CP/CR = HIGH, $U_{High} > 4$ V Off = LOW, $U_{Low} < 1$ V On = HIGH, $U_{High} > 4$ V	

(1 AI = Analog Input, AO = Analog Output, DI = Digital Input, DO = Digital Output, POT = Potential

(2 Internal V_{cc} approx. 10 V

(3 Only one of both signals possible, see section 2.2.1.1

(4 Only during remote control

(5 The error of an analog input/output adds to the general error of the related value on the DC output of the device

2.3.4.4 Resolution

The analog interface is internally sampled and processed by a digital microcontroller. This causes a limited resolution of analog steps. The resolution is the same for set values (VSEL etc.) and actual values (VMON/CMON) and is 26214 for 0...100%, when working with the 10 V range. In the 5 V range this resolution halves. Due to tolerances, the truly achievable resolution can be slightly lower.

2.3.4.5 Overview of the Sub-D Socket

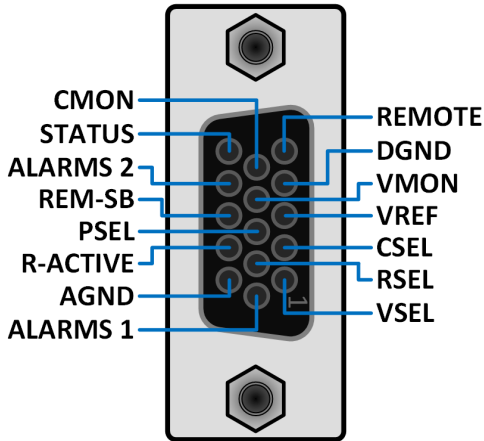

2.3.4.6 Simplified diagram of the pins

	<p>Digital Input (DI)</p> <p>The DI is internally pulled up and thus it requires to use a contact with low resistance (relay, switch, contactor etc.) in order to clearly pull the signal down to DGND.</p>		<p>Analog Input (AI)</p> <p>High resistance input (impedance >40 k...100 kΩ) for an operational amplifier circuit.</p>
	<p>Digital Output (DO)</p> <p>A quasi open collector, realized as high resistance pull-up against the internal supply. The design doesn't allow the pin to be loaded, but to switch signals by sinking current.</p>		<p>Analog Output (AO)</p> <p>Output from an operational amplifier circuit, low impedance. See the specifications table above.</p>

2.3.4.7 Application examples

a) Switching the DC output with pin REM-SB

A digital output, e.g. from a PLC, may be unable to cleanly pull down the pin as it may not be of low enough resistance. Check the specification of the controlling application. Also see the pin diagrams above.

In remote control, pin REM-SB is used to switch the DC output of the device on and off. This function is also available without remote control being active and can on the one hand block the DC output from being switched on in manual or digital remote control and on the other hand the pin can switch the DC output on or off, but not standalone. See below at **Remote control has not been activated**.

REM-SB cannot serve as a safety stop switch to securely deactivate the DC output in case of emergency! For that an external emergency stop system is required.

It's recommended that a low resistance contact such as a switch, relay or transistor is used to switch the pin to ground (DGND).

Following situations can occur:

- Remote control has been activated**

During remote control via analog interface, only pin REM-SB determines the states of the DC output, according to the levels definitions in section 2.3.4.3. The logical function and the default levels can be inverted by a parameter in the setup menu of the device. See section 2.2.1.1.

If the pin is unconnected or the connected contact is open, the pin will be HIGH. With setting "Analog interface -> REM-SB level" being set to "Normal", it requests to switch the DC output on. So when activating remote control, the DC output will instantly switch on.

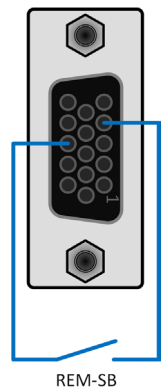

• **Remote control isn't active**

In this mode of operation pin REM-SB can serve as lock, preventing the DC output from being switched on by any means. This results in following possible situations:

DC output	+	Level on pin REM-SB	+	Parameter „REM-SB Level“	→ Behavior
is off	+	HIGH	+	Normal	→ The DC output isn't locked. It can be switched on by pushbutton "On/Off" (front panel) or via command from digital interface.
		LOW	+	Inverted	
	+	HIGH	+	Inverted	→ The DC output locked. It can't be switched on by pushbutton "On/Off" (front panel) or via command from digital interface. When trying to switch on, the device won't react, but generate a requester in the display or, in remote control, return a communication error.
		LOW	+	Normal	

In case the DC output is already switched on, toggling the pin will switch the DC output off, similar to what it does in analog remote control:

DC output	+	Level on pin REM-SB	+	Parameter „REM-SB Level“	→ Behavior
is on	+	HIGH	+	Normal	→ The DC output remains on, nothing is locked. It can be switched on or off by pushbutton or digital command.
		LOW	+	Inverted	
	+	HIGH	+	Inverted	→ The DC output will be switched off and locked. Later it can be switched on again by toggling the pin. During lock, pushbutton or digital command can delete the request to switch on by pin.
		LOW	+	Normal	

b) Remote control of current and power

Requires remote control to be activated (Pin REMOTE = LOW)

The set values PSEL and CSEL are generated from, for example, the reference voltage VREF, using potentiometers for each. Hence the power supply can selectively work in current limiting or power limiting mode. According to the specification of max. 5 mA load for the VREF output, potentiometers of at least 10 kΩ must be used.

The voltage set value VSEL is directly connected to VREF and will thus be permanently 100%.

If the control voltage is fed in from an external source it's necessary to mind the input voltage range for set values (0...5 V or 0...10 V).



Use of the input voltage range 0...5 V for 0...100% set value halves the effective resolution.

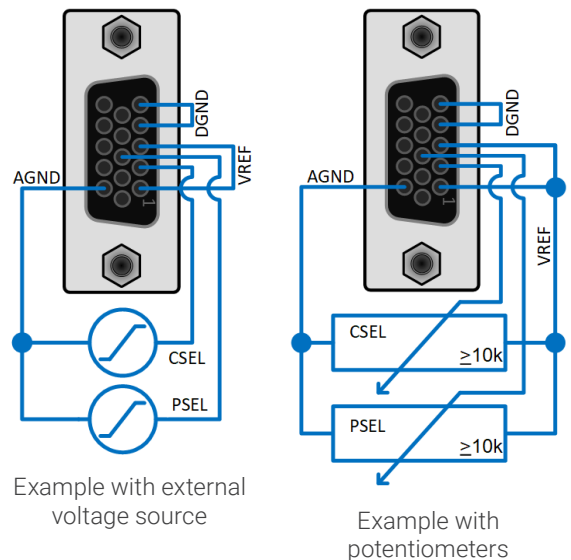

c) Reading actual values

The AI provides the actual values on the DC output as current and voltage monitor. These can be read using a standard multimeter or an analog input of a PLC etc.

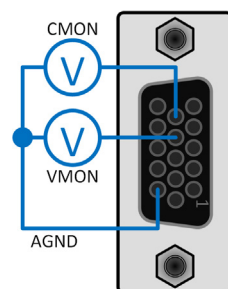

2.3.4.8 Analog interface priority

A new functionality, available for all 10000 series devices with analog interface and from firmware KE 3.10 and HMI 4.09, allows the user to prioritize the analog interface over other remote control interfaces. The rule was and is that no interface, analog or digital, is superior to another in regard of the remote control state. It means, that when a device would be in remote control by any digital interface and the remote control is going to be switched over to analog interface, it would require to leave the digital remote control state first via a specific command sent via the interface in control.

With this feature, when activated (see section 2.2.1.1), the analog interface can take over remote control anytime, except when the condition **Local** is set. In the moment of the switchover, the set values and the DC output status, as given by the pins of the analog interface, would become effective immediately. In the contrary, leaving analog remote control (pin: REMOTE) would neither return the device into the prior state of digital remote control, nor restore the set values and DC condition as they were before. Leaving remote control always keeps the last set of set values, while the DC output condition is determined by the parameter **State after remote** (see section 2.2.1.1).

3. Other applications (2)

3.1 Parallel operation in master-slave (MS)

Multiple devices of same kind can be connected in parallel in order to create a system with higher total current and also higher power. For parallel operation in master-slave mode the units are usually connected on their DC outputs, their Share-Bus and their master-slave bus, which is a digital bus that makes the system work as one big unit regarding adjusted values, actual values and status.

The Share-Bus is intended to balance the units dynamically in their voltage on the DC output, i.e. in CV mode, especially if the master unit runs a dynamic function, in case it features a function generator. In order for this bus to work correctly, at least the DC minus poles of all units have to be connected, because DC minus is the reference for the Share-Bus.

Principle view (without load or source):

Share-Bus connection

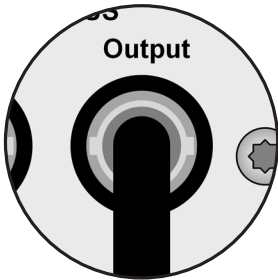

Master-slave bus

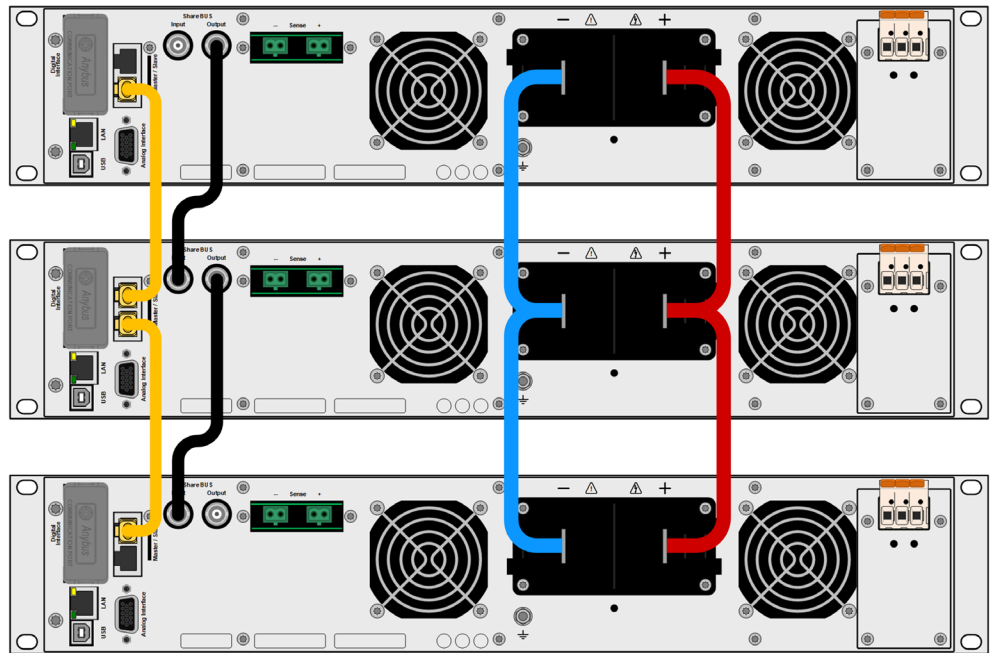
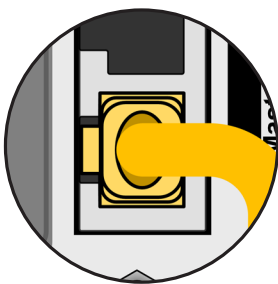

3.1.1 Restrictions

Compared to normal operation of a single device, master-slave operation has some restrictions:

- The MS system reacts partly different in alarm situations (see below in section 3.1.8)
- Though the Share-Bus makes the system react as dynamic as possible, it's still not as dynamic as single unit operation
- Connection to identical models from other series is supported, but limited to series PSI 10000 models which can serve as master units for which the PS 10000 are considered as cheaper slave units

3.1.2 Wiring the DC outputs

The DC output of every unit in the parallel operation is connected with correct polarity to the next unit, using cables or copper bars with a cross section according to the total system current and with short as possible length, so their inductance is as low as possible. The same applies when building several blocks of devices, i. e. a block of power supplies and a block of electronic load, to later connect then in two-quadrant operation. The blocks should be placed as close as possible to each other.

3.1.3 Wiring the Share-Bus

The Share-Bus is wired from unit to unit with standard BNC cables (coaxial, 50 Ω type) with a length of 0.5 m (1.64 ft) or similar. Both sockets are internally connected and are not specifically input or output. The labeling is only for orientation.



- A max. of 64 units can be connected via Share-Bus.
- When connecting the Share-Bus before a device had been configured as Master or Slave, an SF alarm will occur.

3.1.4 Wiring and set-up of the master-slave bus

The master-slave connectors are built-in and can be connected via network cables (≥CAT3, patch cable). After this, MS can be configured manually (recommended) or by remote control. The following applies:

- A maximum of 64 units can be connected via the bus: 1 master and up to 63 slaves.
- Connection only between devices of same kind, i.e. power supply to power supply; connection of different power classes is allowed and supported, e. g. one 1.5 kW 2U with one 3 kW 2U to achieve a total of 4.5 kW, but requires to have at least firmware KE/HMI 3.02 installed on all units
- Linking different series is supported, but limited to:
 - PS 10000 series models can be used as slave units for PSI 10000 series models being the master unit
- Units at the end of the bus must be terminated (see below for more information)



The master-slave bus must not be wired using crossover cables!

Later operation of the MS system implies:

- The master unit displays, or makes available to be read by the remote controller, the sum of the actual values of all the units
- The ranges for setting the values, adjustment limits and protections (OVP etc.) of the master are adapted to the total number of units. For example, if 5 units, each with a power of 3 kW, are connected to a 15 kW system, then the master can be set in the range 0...15 kW.
- Slaves are not operable as long as being controlled by the master
- Slaves which haven't yet been initialized by the master will show the alarm **MSP** in the display. The same alarm is signaled upon MS bus errors.

► How to connect the master-slave bus

1. Switch off all units and connect the master-slave bus with network cables (CAT3 or better, cables not included). It doesn't matter which of the two master-slave sockets (RJ45, backside) is connected to the next unit.
2. Depending on the desired configuration the units are then also connected at their DC terminals. The two units at the beginning and end of the chain must be terminated, while the master requires a separate setting. See the table below.

Termination is done with internal electronic switches which are controlled from within the **Settings** menu of the device in group **Master-slave**. This can be done as part of setting up every unit as master or slave, but should be done before the master is going to be set as **Master**, because doing so immediately triggers a bus initialization. In group **Master-Slave** the termination resistors for BIAS and the bus itself (TERM, see the figure to the right) can be set separately. Settings matrix for the units on the MS bus:

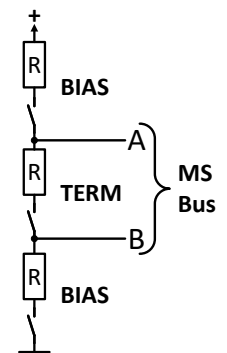

Device position	Termination setting(s)
Master (at end of bus)	BIAS + TERM
Master (central in bus)	BIAS
Slave (at end of bus)	TERM
Slave (central in bus)	-

3.1.5 Mixed systems

As mixed systems following is understood (requires at least firmware KE 3.02):

- Different power classes, like 1.5 kW and 3 kW within one master-slave system
- Different series, specifically PS 10000 series in connection with PSI 10000 series

Both mixed systems are supported, but also their combination. The use of a “PS” series device as slave for a “PSI” series master wasn’t possible before, because the PS had no resistance mode, contrary to the PSI. Today, this is circumvented by the PS now generally having resistance enabled. Vice versa, a PS cannot be the master of a PSI.

When connecting devices with different feature sets it makes sense to select the one with the best configuration as master.

Combining different power classes can have an unexpected side effect, such that the resulting total power, as displayed by the master after the initialization, isn’t the expected one, but lower. This depends on what unit and power class has been picked as master. In such a situation the golden rule is: always select the master from the units with the highest power rating.

Example: you want to connect a 30 kW unit and a 3kW unit in order to achieve 33 kW. Generally, the voltage rating must match, but current and power rating can be different. To be precise, the power rating is decisive. When using the 3 kW unit as master, the total system power will only be 28 kW (with a master running firmware KE 3.02), which is even less than the single 30 kW unit. When, however, switching the master to the 30 kW unit, the system will result in 33 kW total power.

3.1.6 Configuring the master-slave operation

Now the master-slave system has to be configured on each unit. It’s recommended to configure all the slave units first and then the master unit.

► Step 1: Configuring all slave units

1. While the DC output is switched off, tap  on the main screen to access the **Settings** menu. Swipe up to find group **Master-slave** and tap it.
2. Tapping on the blue button text next to **Mode** will open a selector. By selecting **Slave**, if not already set, the master-slave mode is activated and the device is defined as slave. Additionally, the bus termination can be activated here, if required for the currently configured unit.
3. Leave the Settings menu.

After this, the slave is fully configured for master-slave. Repeat the procedure for all other slave units.

► Step 2: Configuring the master unit

1. While the DC output is switched off, tap  on the main screen to access the **Settings** menu. Swipe up to find group **Master-slave** and tap it.
2. Tapping on the blue button text next to **Mode** will open a selector. By selecting **Master**, if not already set, the master-slave mode is activated and the device is defined as master which also automatically enable the BIAS resistor termination, as required for the master.

► Step 3: Initializing the master

When setting a device to Master, it will instantly start to initialize the MS system and the result is displayed in the very same window. In case the initialization is not successful or the number of units or the total power is wrong, it can be repeated in this screen anytime.

Initialization state	Initialized
Number of slaves	1
System voltage	500.0V
System current	40.00A
System power	6.00kW
System resistance	1667.0Ω
	Initialize system

Tapping **Initialize system** repeats the search for slaves in case the detected number of slaves is less than expected, the system has been reconfigured, not all slave units are already set as **Slave** or the cabling/termination is still not OK. The result window shows the number of slaves plus the total current, power and resistance of the MS system.

In case there are no slaves found at all, the master will still initialize the MS system with only itself.



As long as MS mode remains activated, the initialization process of the master-slave system will be repeated each time the master unit is powered. The initialization can also be repeated manually anytime via the Settings menu, in group “Master-Slave”.

3.1.7 Operating the master-slave system

After successful configuration and initialization of the master and slave units, they will show their status in the status area of their displays. The master would show **MS mode: Master (n SI)** while the slave(s) would show **MS mode: Slave** plus **Remote: Slave n**, as long they are in remote control by the master.

From now on the slaves can no longer be controlled manually or remotely, neither via the analog nor via any digital interface. They can, if needed, be monitored via these interfaces by reading the actual values and status.

The display on the master unit will reconfigure after initialization and all set values are reset. The master now displays the set and actual values of the total system. Depending on the number of units, the adjustable current and power range will multiply, while the resistance range will decrease, so the following applies:

- The system, represented by the master, can be treated like a standalone unit
- The master shares the set values etc. across the slaves and controls them
- The master is remotely controllable via its analog or one of its digital interfaces
- All settings for the set values U, I, P and R on the master, plus also all related values from supervision, limits etc. should be adapted to the new total values
- All initialized slaves will reset any limits (U_{Min} , I_{Max} etc.), supervision thresholds (OVP, OPP etc.) and event settings (UCD, OVD etc.) to default values, so these don't interfere with the control by the master. As soon as these values are modified on the master, they are transferred 1:1 to the slave(s).
- During MS operation, it might occur that a slave causes an alarm or an event earlier than the master, due to imbalanced current or slightly faster reaction.



In order to easily restore all these settings to what was configured before activating MS operation, it's recommended to make use of the user profiles (see «2.2.6 Loading and saving user profiles»)

- If one or more slaves report a device alarm, it will be signaled on the master and must also be acknowledged there, so that the slave(s) can continue its/their operation. Since an alarm causes the DC outputs to be switched off and can only reinstate the on/off condition automatically after PF or OT alarms, where the reaction to the alarms is configurable, action from an operator or a remote control software may become necessary.
- Loss of connection to any slave will result in the shutdown of the DC outputs of all units as a safety measure and the master will report this situation in the display with a notification telling "Master-slave protection mode". Then the MS system has to be re-initialized, either with or without prior re-establishment of the connection to the disconnected unit(s).
- All units, even the slaves, can be externally shut down on their DC outputs using the pin REM-SB of the analog interface. This can be used as some kind of "emergency stop", usually by wiring a contact (maker or breaker) to this pin on all units in parallel.

3.1.8 Alarms and other problem situations

Master-slave operation, due to the connection of multiple units and their interaction, can cause additional problem situations which do not occur when operating individual units. For such occurrences the following rules have been defined:

- Generally, if the master loses connection to any slave, it will generate an MSP (master-slave protection) alarm, pop up a message on the screen and switch off its DC output. The slaves will fall back to single operation mode, but also switch off their DC output. The MSP alarm can be deleted by either initializing the master-slave system again. This can be done either in the MSP alarm requester screen or in the MENU of the master or via remote control. Alternatively, the alarm is also cleared by deactivating master-slave on the master unit
- If one or more slave units are cut from AC supply (power switch, blackout, supply undervoltage) and come back later, they're not automatically initialized and included again in the MS system. Then the init has to be repeated.
- If the master unit is cut from AC supply (power switch, blackout) and comes back later, the unit will automatically initialize the MS system again, finding and integrating all active slaves. In this case, MS can be restored automatically.
- If multiple units are defined as master the master-slave system can't be initialized

In situations where one or multiple units generate a device alarm like OVP etc., the following applies:

- Any alarm of a slave is indicated on the slave's display and on the master's display
- If multiple alarms happen simultaneously, the master only indicates the most recent one. In this case, the particular alarms can be read from the slave units displays or via digital interface during remote control or remote supervision.
- All units in the MS system supervise their own values regarding overvoltage, overcurrent and overpower and in case of alarm they report the alarm to the master. In situations where the current is probably not balanced between the units, it can occur that one unit generates an OCP alarm though the global OCP limit of the MS system was not reached. The same can occur with the OPP alarm.

3.2 SEMI F47

SEMI F47 (the SEMI comes from semiconductor) is a specification that demands a device to continue working without interruption in case of a power failure in form of an AC supply undervoltage (here: sag) of max. -50% of the rated line voltage with a max. duration of 1.7 seconds. From firmware KE 3.02 and HMI 3.02 this has been implemented for all 10000 power supply series, but cannot be obtained by installing a firmware update.

SEMI F47 specifies a voltage sag in steps with increasing voltage:

Sag of	Duration at 50 Hz	Duration at 60 Hz	Duration in seconds
50%	10 cycles	12 cycles	0.2
30%	25 cycles	30 cycles	0.5
20%	50 cycles	60 cycles	1 s

3.2.1 Restrictions

- The feature will be disabled automatically and also locked if the device boots with low AC supply voltage present, i. e. 208 V (L-L) instead of the default 400 V (L-L), so it could not bridge the 1.7 s duration of the F47 pulse anymore. It means that SEMI F47 isn't available while derating is active.
- It requires a decreased max. power, compared to the rated power of the particular model, thus SEMI F47 is also a sort of derating, but it's not depending on the line voltage but what the AC input circuit (PFC) can cover without running into a power fail. This reduced power rating is activated and deactivated together with SEMI F47

3.2.2 Adjustments

SEMI F47 can either be activated/deactivated manually on the HMI (see section 2.2.1.7) or a digital interface, unless blocked due to the current device state.

3.2.3 Application

The feature can be activated at any time, unless blocked to the current devices, for example when low voltage derating is already active (see section 2.1.3.7). With the release of firmwares KE 3.10 and HMI 4.09, the mode **Dynamic** has been added. When just activating SEMI F47 as before, the device will pop up a message after leaving the menu, informing about the altered situation and also instantly reduce the max. available power, as well as adjust the power set value, should the currently adjusted one be higher than the new maximum. When deactivating the feature, it acts vice versa, only the power set value remains unaltered. Due to the fact that the activation of SEMI F47 is stored beyond shutting down the device, it would directly boot into SEMI F47 mode during the next start, also showing that above mentioned requester once after the start (the requester can be deactivated). When using the new mode **Dynamic**, the message won't show. Then the available maximum power isn't reduced permanently, as with mode **Enabled**, but temporarily, for the duration of the sag.

If later a voltage sag occurs, the level of sag or the duration decides whether the device continues its operation without switching the DC output off or if it would show a **PF** alarm. Without SEMI F47 being activated, the PF alarm would appear immediately while with activated SEMI F47 it's delayed for at least 2 seconds or will never occur. In this case, the device wouldn't show any reaction to the sag, nor register the occurrence in any form.

4. Service and maintenance (2)

4.1 Firmware updates



Firmware updates should only be installed when they can eliminate existing bugs in the firmware in the device or contain new features.

The firmware of the control panel (HMI), of the communication unit (KE) and the digital controller (DR), if necessary, is updated via the rear USB port. For this the software EA Power Control is needed, which is included with the device or available as download from our website together with the firmware update, or upon request.

However, it's advisable not to install updates promptly. Every update includes the risk of an inoperable device or system. We recommend to install updates only if..

- an imminent problem with your device can be solved directly, especially if we suggested to install an update during a support case
- a new feature has been added which you definitely want to use. In this case, the full responsibility is transferred to you.

The following additionally applies in connection with firmware updates:

- Simple changes in firmwares can have crucial effects on the application the devices are used in. We recommend to study the list of changes in the firmware history very thoroughly.
- Newly implemented features may require an updated documentation (user manual and/or programming guide, as well as LabView VIs), which is often delivered only later, sometimes significantly later

EA Elektro-Automatik GmbH

Helmholtzstr. 31-37
41747 Viersen
Germany

Phone: +49 2162 3785 - 0
ea1974@elektroautomatik.com

www.elektroautomatik.com

www.tek.com

