

# Technical Reference



## **TDS3SDI 601 Digital Video Application Module**

**071-0689-00**

This document supports firmware version 2.20  
and above.

**[www.tektronix.com](http://www.tektronix.com)**

Copyright © Tektronix, Inc. All rights reserved.

Tektronix products are covered by U.S. and foreign patents, issued and pending. Information in this publication supercedes that in all previously published material. Specifications and price change privileges reserved.

Tektronix, Inc., P.O. Box 500, Beaverton, OR 97077

TEKTRONIX and TEK are registered trademarks of Tektronix, Inc.

DPX is a trademark of Tektronix, Inc.

## **WARRANTY SUMMARY**

Tektronix warrants that the products that it manufactures and sells will be free from defects in materials and workmanship for a period of three (3) years from the date of shipment from an authorized Tektronix distributor. If a product proves defective within the respective period, Tektronix will provide repair or replacement as described in the complete warranty statement.

To arrange for service or obtain a copy of the complete warranty statement, please contact your nearest Tektronix sales and service office.

**EXCEPT AS PROVIDED IN THIS SUMMARY OR THE APPLICABLE WARRANTY STATEMENT, TEKTRONIX MAKES NO WARRANTY OF ANY KIND, EXPRESS OR IMPLIED, INCLUDING WITHOUT LIMITATION THE IMPLIED WARRANTIES OF MERCHANTABILITY AND FITNESS FOR A PARTICULAR PURPOSE. IN NO EVENT SHALL TEKTRONIX BE LIABLE FOR INDIRECT, SPECIAL OR CONSEQUENTIAL DAMAGES.**





# Table of Contents

|                                     |            |
|-------------------------------------|------------|
| <b>General Safety Summary</b> ..... | <b>iii</b> |
| <b>Preface</b> .....                | <b>v</b>   |
| Contacting Tektronix .....          | vi         |

## Getting Started

|  |   |
|--|---|
| Installing the Application Module Firmware ..... | 1 |
| Installing the Application Module .....          | 4 |
| Checking Module Installation .....               | 7 |
| Troubleshooting Module Installation .....        | 8 |

## Operating Basics

|  |    |
|--|----|
| The 601 Digital Video Module .....       | 9  |
| 601 Digital Video Feature Overview ..... | 10 |
| Accessing 601 Video Functions .....      | 12 |

## Reference

|  |    |
|--|----|
| 601 Digital Video Application Module Conventions ..... | 15 |
| Video QuickMenu .....                                  | 16 |
| Alternating Trigger Source Function .....              | 22 |
| New Functions in the Video Trigger Menu .....          | 23 |
| New Apps > 601 Module Menu .....                       | 27 |
| New Functions in the Display Graticule Menu .....      | 28 |
| Changes to the Acquire Menu .....                      | 31 |
| Examples .....   | 32 |

## Appendix

|                                  |    |
|----------------------------------|----|
| Appendix A: Specifications ..... | 43 |
|----------------------------------|----|

## Table of Contents

---

# General Safety Summary

Review the following safety precautions to avoid injury and prevent damage to this product or any products connected to it. To avoid potential hazards, use this product only as specified.

*Only qualified personnel should perform service procedures.*

While using this product, you may need to access other parts of the system. Read the *General Safety Summary* in other system manuals for warnings and cautions related to operating the system.

## To Avoid Fire or Personal Injury

**Do Not Operate With Suspected Failures.** If you suspect there is damage to this product, have it inspected by qualified service personnel.

**Do Not Operate in Wet/Damp Conditions.**

**Do Not Operate in an Explosive Atmosphere.**

## Safety Terms and Symbols

**Terms in This Manual.** The following term appears in this manual:



---

**CAUTION.** *Caution statements identify conditions or practices that could result in damage to this product or other property.*

---

## Preventing Electrostatic Damage

---



**CAUTION.** *Electrostatic discharge (ESD) can damage components in the oscilloscope and its accessories. To prevent ESD, observe these precautions when directed to do so.*

---

**Use a Ground Strap.** Wear a grounded antistatic wrist strap to discharge the static voltage from your body while installing or removing sensitive components.

**Use a Safe Work Area.** Do not use any devices capable of generating or holding a static charge in the work area where you install or remove sensitive components. Avoid handling sensitive components in areas that have a floor or benchtop surface capable of generating a static charge.

**Handle Components Carefully.** Do not slide sensitive components over any surface. Do not touch exposed connector pins. Handle sensitive components as little as possible.

**Transport and Store Carefully.** Transport and store sensitive components in a static-protected bag or container.



# Preface

The TDS3SDI 601 Digital Video application module provides additional functions to the TDS3000 series Digital Phosphor Oscilloscope. These new functions make it easier to capture, display, and measure video waveforms from both broadcast and non-broadcast equipment.

This Technical Reference describes the capabilities, operation, and applications of the 601 Digital Video module. The following table shows where to find information in this manual.

| <b>If you are looking for:</b> | <b>Turn to:</b>   |
|--------------------------------|---|
| Installation information       | <i>Installing the Application Module Firmware</i> on page 1 |
| Product overview               | <i>The 601 Digital Video Module</i> on page 9               |
| Basic operating instructions   | <i>Accessing 601 Video Functions</i> on page 12             |
| Function details               | <i>Reference</i> section starting on page 15                |
| Application examples           | <i>Examples</i> section starting on page 32                 |

## Contacting Tektronix

|                  |  |
|------------------|--|
| Product support  | <p>For questions about using Tektronix measurement products, call toll free in North America:<br/>1-800-833-9200<br/>6:00 a.m. – 5:00 p.m. Pacific time</p> <p>Or contact us by e-mail:<br/>support@tektronix.com</p> <p>For product support outside of North America, contact your local Tektronix distributor or sales office.</p> |
| Service support  | <p>Tektronix offers a range of services, including Extended Warranty Repair and Calibration services. Contact your local Tektronix distributor or sales office for details.</p> <p>For a listing of worldwide service centers, visit our web site.</p>   |
| Toll-free Number | <p>In North America:<br/>1-800-833-9200<br/>An operator can direct your call.</p>  |
| Postal Address   | <p>Tektronix, Inc.<br/>Department or name (if known)<br/>P.O. Box 500<br/>Beaverton, OR 97077<br/>USA</p>  |
| Web site         | <p><a href="http://www.tektronix.com">www.tektronix.com</a></p>  |



# Getting Started

This section describes how to install and check the TDS3SDI 601 Digital Video application module.

## Installing the Application Module Firmware

---

***NOTE.** You must do the firmware installation procedure the first time you install a new application module. If you do not update the oscilloscope firmware, the new application module may not function at all, or may not function correctly. It is strongly recommended that you install new firmware when the oscilloscope determines an update is necessary.*

---

To install the application module firmware, do these steps:

1. Save any oscilloscope settings and/or reference waveforms to floppy disk before doing these steps.
2. Turn the oscilloscope power off.
3. If the application module came with one or more floppy disks, insert floppy disk 1 into the floppy disk drive.
4. Power on the oscilloscope. The oscilloscope checks if a firmware update is required. If an update is required, go to page 2. If an update is not required, go to page 3.

### Firmware Update Required

If a firmware update is necessary, the oscilloscope displays the following message:

“This procedure will replace the firmware in the instrument with firmware from the floppy disk. This procedure will take approximately 5 minutes.

Caution: Do not turn the instrument off or eject the floppy disk until prompted.

Push ‘OK Load New Firmware’ to proceed.

Push MENU OFF to abort this procedure.”

1. Push **OK Load New Firmware** to begin loading the firmware. The oscilloscope shows a clock icon on the screen while loading the firmware. If a second firmware floppy disk is required, the oscilloscope will instruct you to eject the first disk and insert the second disk.

If you do not want to upgrade the firmware, push **MENU OFF**.

When the firmware upgrade is complete, the oscilloscope will restart automatically with the new firmware.

---

**NOTE.** *If you power off the oscilloscope, eject the floppy disk before prompted, or there is a power outage during the firmware upgrade process, you must restart the firmware upgrade procedure starting at step 2 on page 1.*

---

2. The oscilloscope may also display the following message:  
“WARNING! This instrument is not calibrated. You must run Signal Path Compensation (SPC) in order to calibrate the instrument.  
  
SPC is adversely affected by input signals with AC components. Disconnect or otherwise remove these signals prior to running SPC. SPC will take approximately 10 minutes to run.  
  
Push ‘OK Compensate Signal Paths’ to begin the calibration procedure. Or, you may run SPC in the UTILITY Cal menu.”
3. If the instrument has been operating for 20 minutes or longer in the ambient temperature at which it will be used, disconnect all signals and push **OK Compensate Signal Paths** to run SPC. You can also ignore this step for now and run SPC at a later time.
4. Proceed to step 1 of *Firmware Update Not Necessary* (below) to finish the installation.

#### **Firmware Update Not Required**

If a firmware update is not necessary, the oscilloscope displays the following message:

“A floppy disk containing instrument firmware has been detected. However, the firmware on the disk is not newer than the instrument firmware. Therefore, no firmware upgrade is required.

Push MENU OFF to remove this message”

1. Push the **MENU OFF** button.
2. Eject the floppy disk.
3. You are done installing the firmware. Go to *Installing the Application Module* on page 4.

## Installing the Application Module

The following figures show how to install the TDS3SDI application module.



---

**CAUTION.** *Turn off power before installing or removing a module. To avoid damaging the oscilloscope or application module, observe the ESD precautions described on page iv.*

---

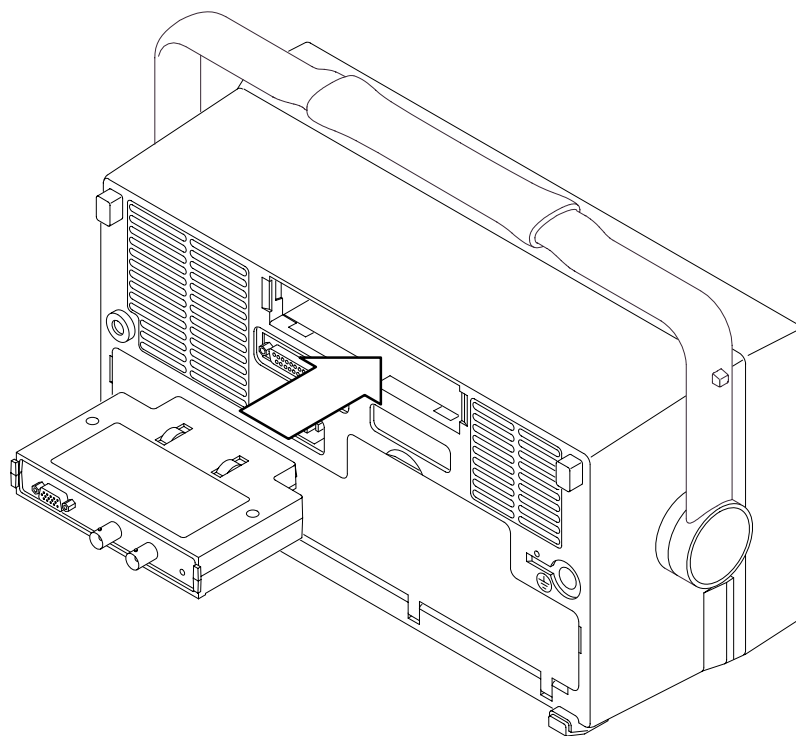

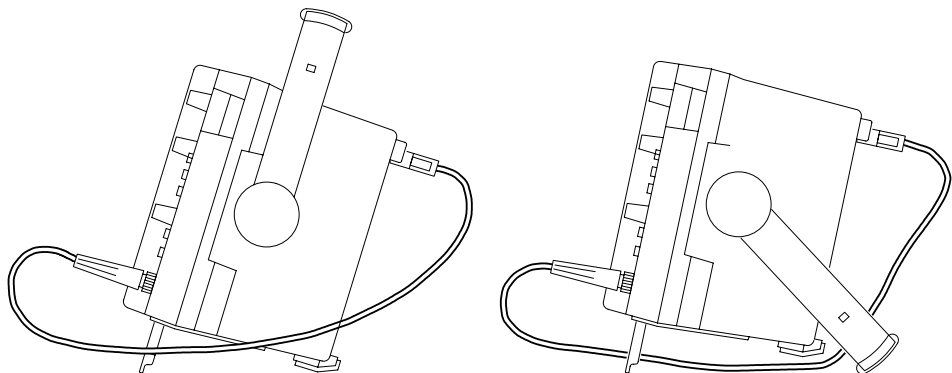
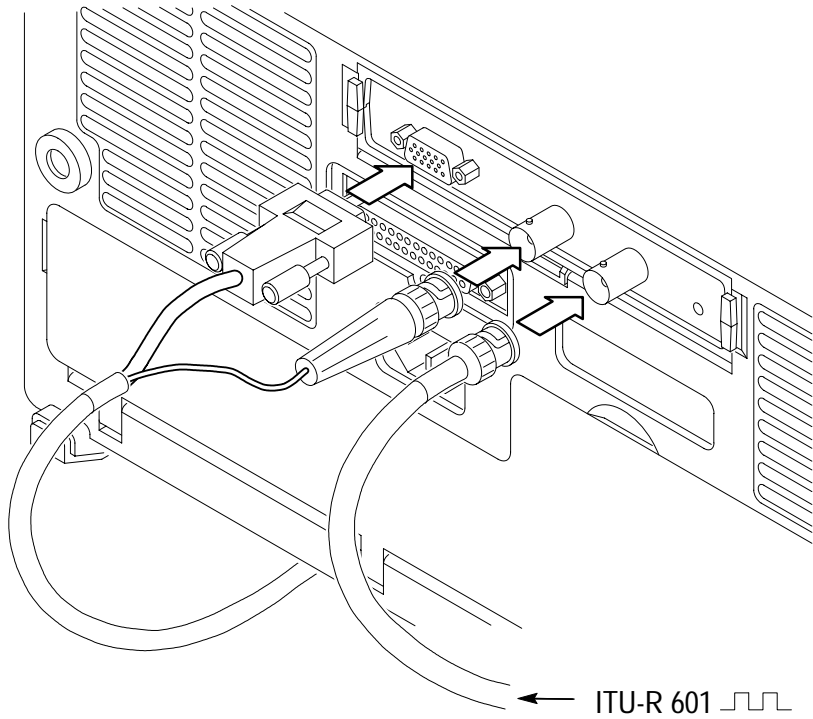

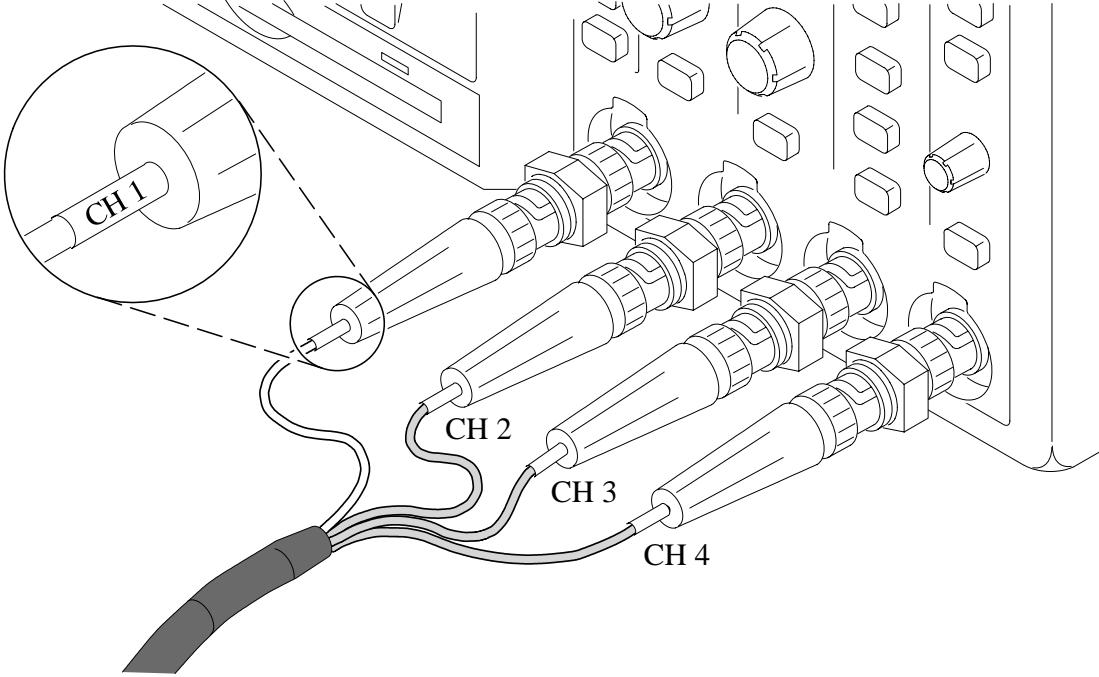
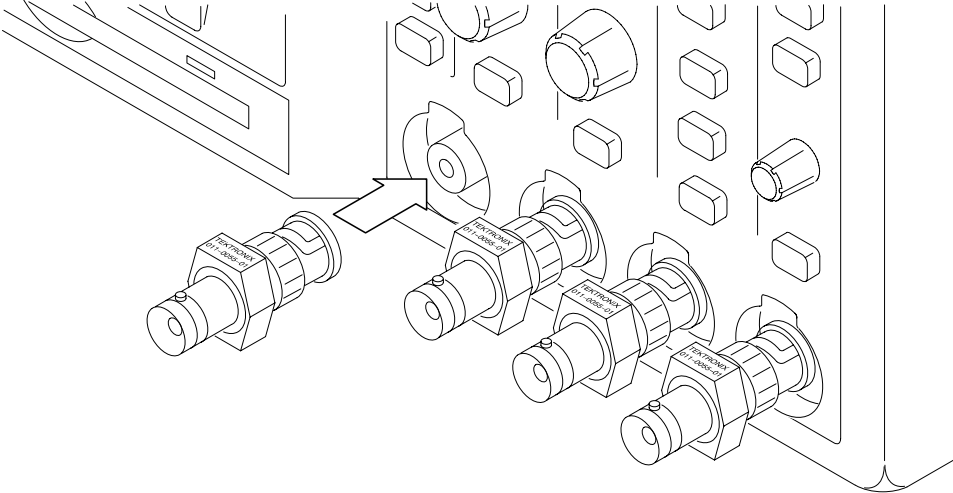



## Checking Module Installation

Do these steps to check that the TDS3SDI 601 Digital Video application module and firmware are correctly installed.

1. Power on the oscilloscope. Look at the oscilloscope startup screen; it should list the 601 module. If the oscilloscope displays a message stating that there is incompatible firmware, power off the oscilloscope and do the steps in the *Installing the Application Module Firmware*, starting at step 2 on page 1.
2. Push the **QUICKMENU** panel button.
3. Push the **Menu** bottom button to select **Video**.
4. Push the **SUBMENU** bottom button to check that it displays **SDTV/HDTV** and **ITU-R 601**.

If the oscilloscope does not show these menu items, go to *Troubleshooting Module Installation* on page 8.

---

**NOTE.** *You do not need to reinstall the firmware if you remove and reinstall an application module. However, the features provided by that application module are not available until you reinstall the module.*

---

## Troubleshooting Module Installation

If the oscilloscope does not recognize the application module at power-up, do these steps:

1. Turn off the oscilloscope.
2. Following the ESD precautions listed on page iv, remove the application module.
3. Examine the oscilloscope and application module contacts for damage.
4. Reinstall the application module into the oscilloscope.
5. Reinstall the firmware (page 1).
6. Turn on the oscilloscope. If the oscilloscope still does not display the application menu items as listed in *Checking Module Installation*, power off the oscilloscope and contact the nearest Tektronix service center.

# Operating Basics

This section describes the features of the 601 Digital Video application module and how to access the new video functions.

## The 601 Digital Video Module

The following figure and table describe the 601 Digital Video module connectors and indicators.

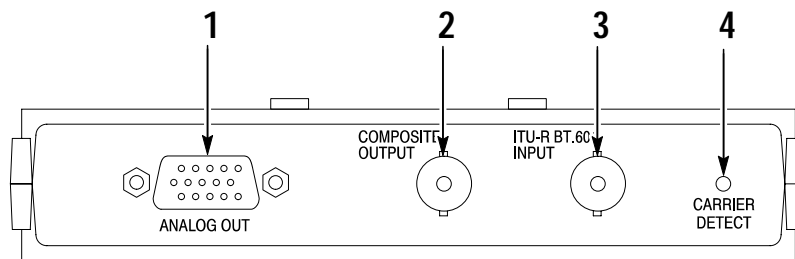

| Item | Description  |
|------|--|
| 1    | 15-pin connector for analog component signal output. Connect the output to oscilloscope channels 2 through 4 using the supplied cable assembly.  |
| 2    | BNC connector for composite video output signal. Connects to channel 1 of the oscilloscope. You can also connect this signal to a video monitor. |
| 3    | BNC connector for 601 video signal input.  |
| 4    | Green LED that lights when the module recognizes a valid 601 video signal.   |

## 601 Digital Video Feature Overview

This section provides an overview of the 601 Digital Video module features.

### **ITU-R BT.601 Signal Conversion**

The 601 Digital Video module converts serial digital video to analog video composite and component (RGB or YPbPr) signals connected to the oscilloscope inputs. The 601 digital video functions also provide error detection and counting, as well as signal equalization for remotely-connected video equipment signals (typically up to 250 meters of Belden 8281 or equivalent cable).

### **Video QuickMenu**

Use the video QuickMenu to display bottom and side menus that contain commonly-used video functions useful for displaying and measuring video signals.

### **Video Autoset**

Use the autoset function to automatically adjust the vertical, horizontal, and video trigger settings to display a video waveform triggered on all lines or fields. You can then manually adjust controls to optimize the display.

### **Vectorscope**

Use the Vectorscope function with 100% and 75% color bars to analyze 601 digital, standard video, or analog HDTV color difference video signals using a familiar display format.

### **Video Picture**

Use the Video Picture function to display a monochrome picture of a composite or luminance video signal.

### **Video Graticules**

Use the video graticule functions to change the standard oscilloscope graticule to either IRE (for 525/NTSC signals) or mV (for PAL/SECAM or component signals) with the vertical scale set to 143 mV/div. The video graticules include labeled marks for manual component signal measurement. The standard graticules are also available.

### **Trigger On Specific Lines (Line Select)**

Use the trigger on lines function to trigger the oscilloscope on specific lines in broadcast and non-broadcast (custom) video waveforms.

### **Analog HDTV**

Use the analog HDTV functions to trigger the oscilloscope on different HDTV formats.

### **Field Holdoff**

Use the field holdoff function to specify a number of fields to wait before re-enabling triggering. This lets the oscilloscope always trigger on a single field (for example, field 1 or field 3 of NTSC) instead of on both field 1 and field 3.

### **Custom Video**

Use the custom video function to specify custom horizontal scan rates in order to trigger on non-broadcast video waveforms, such as those used by computer monitors and medical equipment displays.

## Accessing 601 Video Functions

The following text describes how to access the new 601 Digital Video module functions in the menu system. Go to the *Reference* section of this manual for more information on the individual function menus.

### Video QuickMenu

The video QuickMenu contains bottom and side menu items that are useful for quickly displaying and measuring analog SDTV/HDTV and 601-encoded video signals. Vectorscope and Video Picture are accessible from the video QuickMenu.

To display the video QuickMenu, do these steps:

1. Push the **QUICKMENU** panel button.
2. Push the **Menu** bottom button to select **Video**.
3. Push the **SUBMENU** button to select a video signal standard (**SDTV/HDTV** or **ITU-R 601**) and display bottom and side menus.

### ITU-R 601 Settings in the UTILITY > Apps Menu

To access the 601 Digital Video functions, do these steps:

1. Push the **UTILITY** panel button.
2. Push the **System** bottom button to select **Apps**.
3. Push the **Module** button to select **ITU-R 601**. The bottom and side menus change to show the 601 functions.

### Video Trigger Settings in the Trigger Menu

To access the new video trigger functions, do these steps:

1. Push the Trigger **MENU** panel button.
2. Push the **Type** bottom button to select **Video**. The new video trigger functions are part of the Standard trigger menus.

---

***NOTE.** There are no ITU-R 601 functions in the Trigger menu.*

---

### Video Autoset Settings in the Acquire Menu

Video Autoset automatically sets up the oscilloscope to trigger and display a composite video waveform. You can run video Autoset from the Acquire menu or the video QuickMenu.

---

***NOTE.** Video Autoset is only available through the **ACQUIRE** or **QuickMenu** menus. The **AUTOSET** front-panel button always runs the standard oscilloscope edge-trigger autoset function.*

---

To access the video autoset function from the Acquire menu, do these steps:

1. Push the Acquire **MENU** front panel button to display the Acquire menu.
2. Push the **Autoset** bottom button to display the Autoset side menu.
3. Push the **Video Autoset** side button to automatically display a composite video waveform triggered on all lines.

### **Vectorscope and Video Picture in the DISPLAY Menu**

To access Vectorscope or Video Picture functions from the Display menu, do the following:

1. Push the **DISPLAY** panel button.
2. Push the **Video Picture** bottom button to display the Video Picture side menu.
3. Push the **Vectorscope** bottom button to display the Vectorscope side menu.

---

***NOTE.** The DISPLAY Video Picture menu lets you change the picture contrast and brightness settings. These settings are not available in the video QuickMenu.*

---

### **Video Graticules (IRE/mV) in the DISPLAY Menu**

To change the screen graticule to IRE or mV format, do the following:

1. Push the **DISPLAY** panel button.
2. Push the **Graticule** bottom button to display the graticule side menu. Push the **-More-** button to display the IRE and mV buttons if they are not already displayed.
3. Select **IRE** or **mV** on the side menu.



# Reference

The 601 Digital Video application module affects the functions of several menus. The following sections describe these changes in more detail.

## 601 Digital Video Application Module Conventions

The following conventions apply to one or more of the 601 Digital Video functions:

- This firmware update adds alternating trigger source capability to the oscilloscope. Refer to page 22 for an explanation of the alternating trigger source function.
- You can use other menus while using the video QuickMenu. For example, you can push the MEASURE button to set up and take waveform measurements, and then push the QUICKMENU button to return to the video QuickMenu.
- You cannot use video triggering to arm B triggering.
- You can trigger on and view SDTV and HDTV analog signals. The 601 Digital Video module does not convert HDTV digital formats (SMPTE 292M) to analog.
- The oscilloscope does not have video signal clamping. Tektronix offers an optional Video Display Clamp module (part number 013-0278-00) that provides video signal clamping.
- The TDS3SDI module is optimized for the TDS3054 DPO oscilloscope. The module provides reduced performance in other TDS3000 Series oscilloscopes.

## Video QuickMenu

The 601 Digital Video application module provides a QuickMenu for video functions. Video QuickMenu bottom and side menu items contain key video-related functions to let you quickly acquire, display, and measure video signals. The following tables describe the video QuickMenu.

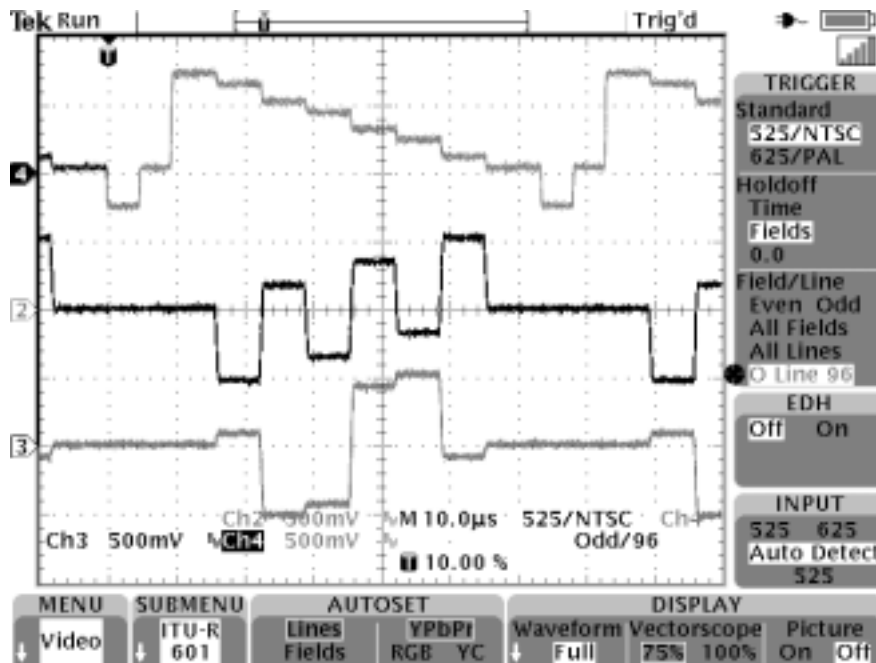

There are two video types in the SUBMENU button: ITU-R 601 and SDTV/HDTV. The following menu descriptions apply to both video types unless marked otherwise.

**Video QuickMenu: bottom menu**

| Menu Item                      | Value(s)                         | Description   |
|--------------------------------|----------------------------------|---|
| SUBMENU                        | SDTV/HDTV<br>ITU-R 601           | Displays the bottom and side menu items for the selected video standard.  |
| AUTOSET                        | Lines<br>Fields                  | Automatically displays a video graticule and adjusts the vertical, horizontal, and video trigger settings to display a video waveform triggered on all lines or all fields. |
|                                | YPbPr<br>RGB<br>YC<br>(601 only) | Automatically adjusts the vertical, horizontal, and video trigger settings to display the selected component waveforms.   |
| ACQUIRE<br>(SDTV/HDTV<br>only) | Fast Trig                        | Sets the acquisition mode to Fast Trigger (500 points).   |
|                                | Normal                           | Sets the acquisition mode to Normal (10K points).   |

## Video QuickMenu: bottom menu (cont.)

| Menu Item                                     | Value(s)    | Description  |
|---|-------------|--|
| DISPLAY:<br>Waveform                          | Full        | Turns off the Vectorscope or Video Picture and displays waveforms using the the full graticule.  |
|   | IRE<br>mV   | Turns off the Vectorscope or Video Picture, displays an IRE or mV video graticule, and sets the vertical scale to 143 mV/div.  |
| DISPLAY:<br>Vectorscope                       | 75%<br>100% | Enables Vectorscope mode and selects 75% or 100% color bars. Select DISPLAY: Waveform or DISPLAY:Picture to turn off Vectorscope.  |
| DISPLAY:<br>Picture<br>(SDTV and<br>601 only) | On<br>Off   | Turns on or off the Video Picture, which displays an image of the composite or luminance signal connected to channel 1. Video Picture is not available when triggering on SECAM, Custom, or HDTV signals.<br><br>Turning Picture Off returns the oscilloscope to the state prior to turning Picture On, except for any values changed while in Video Picture mode. |

## Key Points

**DISPLAY Waveform.** Pushing the Waveform button automatically turns off Video Picture or Vectorscope.

**DISPLAY Vectorscope.** Pushing the Vectorscope button the first time enables the Vectorscope. Subsequent button pushes selects 75% or 100% color bars.

The Vectorscope mode uses the oscilloscope XY mode; therefore, all XY restrictions as listed in the *TSD3000 Series Digital Phosphor Oscilloscope User Manual* apply to Vectorscope.

### Video QuickMenu Side Menu Items

The side menu items are the same for both video submenu types (ITU-R 601 and SDTV/HDTV) unless marked otherwise.

#### Video QuickMenu: side menu

| Side Menu Item                 | Value   | Description   |
|--------------------------------|---|---|
| Format<br>(SDTV/<br>HDTV only) | SDTV<br>HDTV  | Sets the oscilloscope to trigger on standard (SDTV) or high-definition (HDTV) analog video signals.               |
| Standard<br>(SDTV only)        | 525/NTSC<br>625/PAL<br>SECAM                                  | Sets the SDTV video standard on which to trigger. Displayed when SDTV is selected in the Format side menu.        |
| (HDTV only)                    | 1080i 60 50<br>1080p 24 25<br>1080/24sF<br>720p/60<br>480p/60 | Sets the HDTV analog video standard on which to trigger. Displayed when HDTV is selected in the Format side menu. |
| Holdoff                        | Time  | Sets the trigger holdoff time value. Use the general purpose knob to change the holdoff time value.               |

## Video QuickMenu: side menu (cont.)

| Side Menu Item                 | Value                   | Description   |
|--------------------------------|-------------------------|---|
| Holdoff<br>(cont.)             | Fields                  | Sets the trigger holdoff fields value. Use the general purpose knob to change the holdoff fields value, from 0 to 8.5 fields, in increments of 0.5.                                       |
| Source<br>(SDTV/<br>HDTV only) | Ch 1 2 3 4<br>Ch 1 2    | Sets which input to use for triggering the oscilloscope. To trigger on alternating video signal sources, use the front-panel Trigger menu.  |
| Field/Line                     | Even                    | Triggers the oscilloscope on all even video fields.   |
|                                | Odd                     | Triggers the oscilloscope on all odd video fields.  |
|                                | All Fields<br>All Lines | Triggers the oscilloscope on all fields or all lines.   |
|                                | O/E Line <i>n</i>       | Triggers the oscilloscope on a specific video field ( <b>Odd</b> or <b>Even</b> for 525/NTSC) and line number ( <b><i>n</i></b> ). Use the general purpose knob to change the line value. |
| EDH<br>(601 only)              | On Off                  | Turns on or off EDH detection and error count status readouts. Turning EDH on resets the error count to zero.   |
| Input<br>(601 only)            | 525<br>625              | Sets the oscilloscope to decode and trigger on 525 or 625-line video signals.   |
|                                | Auto<br>Detect          | Sets the oscilloscope to automatically detect and trigger on either 525 or 625-line video signals.  |

## Key Points

**601 Autoselect.** While in 601 mode, pushing **AUTOSET Lines/Fields** turns off 601 module component signal output, turns off oscilloscope channels 2 through 4, and turns on oscilloscope channel 1 to display the composite video waveform. Pushing **AUTOSET YPbPr/RGB/YC** turns on 601 module component signal output, turns off oscilloscope channel 1, and turns on channels 2 through 4 (or 3 and 4 for YC) to display the component signal waveforms.

**601 Signal Strength Meter.** The ITU-R 601 QuickMenu displays a small signal strength meter directly above the side menus. The meter shows relative strength of the 601 digital signal. The 601 module equalizes weak input signals.

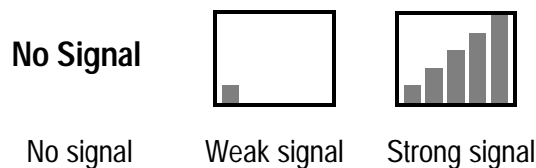

**Video Submenus and Triggers.** Selecting a submenu (ITU-R 601 or SDTV/HDTV) does not automatically enable the corresponding video trigger. Because some video signal types have more than one video standard, you must select a video standard in the side menu to trigger on that type of video signal.

The oscilloscope uses the currently-enabled video trigger setting until you select a new trigger. For example, if you are triggering on an HDTV signal, then select the ITU-R 601 submenu, the oscilloscope continues to use the HDTV trigger setting until you select a trigger in the ITU-R 601 side menu.

**AUTOSET Lines/Fields and Trigger All Lines/All Fields.** The AUTOSET Lines/Fields functions (video QuickMenu bottom menu) differ from the All Fields/All Lines side menu functions in that the AUTOSET Lines/Fields functions change a number of instrument settings in addition to the video trigger type. The All Fields/All Lines side menu only changes the video trigger type.

## Alternating Trigger Source Function

Alternating trigger source is an edge-trigger function that uses each active channel as a trigger source in turn, starting with the lowest-numbered active channel and going to the highest-numbered active channel. The alternating trigger source function is available in all oscilloscope edge-type trigger menus (video or normal oscilloscope modes) excluding logic triggers, whether or not the 601 Digital Video module is installed.

Alternating trigger source uses the current trigger settings to trigger on each active channel; there is no separate trigger setup for each channel. Also, alternating source does not use EXT or Line signals as trigger sources.

---

**NOTE.** *Due to image persistence, all active channels may appear to display simultaneously. However, this does not mean that the displayed signals are synchronized.*

*Because alternating trigger uses the same trigger settings for all source signals, the trigger settings must be able to trigger on all active signals. If one or more of the source signals do not meet the trigger settings, the oscilloscope either waits for that source channel to trigger (Normal trigger mode) or autotrigger (Autotrigger mode).*

---



## New Functions in the Video Trigger Menu

The 601 Digital Video application module adds the following functions to the video trigger menu (Trigger MENU > Type=Video):

| Standard menu  | Bottom menu    | New/changed side menu   |
|--|----------------|---|
| 525/NTSC<br>625/PAL<br>SECAM<br>HDTV (new)<br>Custom (new) | Source         | Alternating (all active channels). Refer to page 22 for a description of the alternating trigger source function. |
|  | Trigger On     | Line Number and Odd/Even fields. Refer to page 25 for a description.  |
|  | Mode & Holdoff | Holdoff (Fields). Refer to page 24 for a description.   |
| HDTV (new)   | Format         | Displays a list of analog HDTV signal formats on which to trigger.  |
| Custom (new)   | Trigger On     | Progressive/Interlaced: Sets to trigger on interlaced or progressive (non-interlaced) video waveforms.            |
|  |                | Odd/Even: Sets to trigger on odd or even fields. Only enabled when Interlaced is selected.                        |
|  | Scan Rate      | Displays custom horizontal scan rate ranges on which to trigger.  |

### Key Points

**Holdoff (Fields).** This function lets you specify a number of fields to wait before re-arming the video trigger. For example, when you select to trigger on odd fields, the oscilloscope triggers on all odd-numbered fields (1 and 3 for NTSC signals; 1, 3, 5, and 7 for PAL/SECAM signals). However, the default video trigger cannot trigger on just odd field 1.

Default: trigger on an odd field triggers on all odd fields (example NTSC signal).



**T** = Trigger points

You can use the Holdoff Field function to trigger the oscilloscope on the same field. The holdoff process begins when the oscilloscope recognizes a video trigger event. The oscilloscope acquires the signal and disables the trigger system until the specified number of fields have passed. The oscilloscope then re-arms the video trigger system and waits for the next valid video trigger. This enables the oscilloscope to always trigger on the same field.

Holdoff Field: holding off 2.5 fields triggers on the same odd field (example NTSC signal).

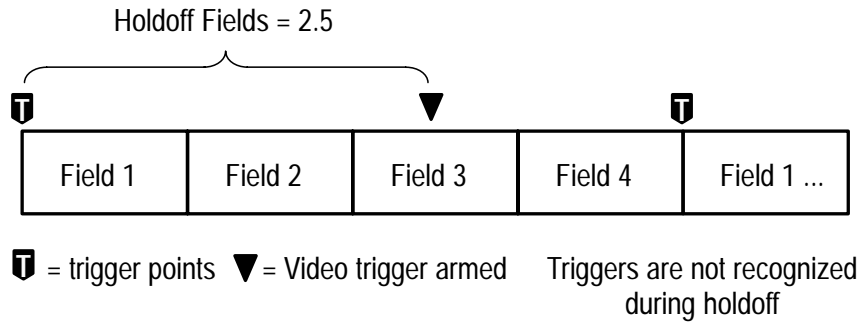

Although Holdoff Field triggering enables you to trigger on the same field, it does not allow you to specify the exact field on which to trigger. Use the SINGLE SEQ button to retrigger the oscilloscope on a particular field.

**Trigger On Odd/Even Line Number.** Sets the specific video field (Odd or Even) and line number on which to trigger. Use the general purpose knob to change values.

For 525/NTSC, the range of line values is 1 through 263 for odd fields, and 1 through 262 for even fields. Increasing the line count when at odd field line 263 changes the setting to even field line 1. You can also push the Odd/Even button to switch between odd and even lines of the same line number.

For 625/PAL and SECAM, the range of line values is 1 through 625. Increasing the line count when at line 625 changes the setting to line 1.

**HDTV Format.** The HDTV Format function lets you select the analog HDTV signal format on which to trigger. Available HDTV formats are:

| Format    | Description   |
|-----------|---|
| 1080i/60  | 1080 active lines, 1125 lines, 1920 x 1080 pixel, interlaced, 60 fps                    |
| 1080i/50  | 1080 active lines, 1125 lines, 1920 x 1080 pixel, interlaced, 50 fps                    |
| 1080p/24  | 1080 active lines, 1125 lines, 1920 x 1080 pixel, progressive, 24 fps                   |
| 1080/24sF | 1080 active lines, 1125 lines, 1920 x 1080 pixel, progressive (segmented frame), 24 fps |
| 1080p/25  | 1080 active lines, 1125 lines, 1920 x 1080 pixel, progressive, 25 fps                   |
| 720p/60   | 720 active lines, 750 lines, 1280 x 720 pixel, progressive, 60 fps                      |
| 480p/60   | 480 active lines, 525 lines, 640 or 704 x 480 pixel, progressive, 60 fps                |

**Custom.** The Custom video menu lets you select horizontal scan rate ranges to view non-broadcast video waveforms from security, computer, and medical equipment. Scan Rate sets the oscilloscope to search for negative sync pulses within the selected range.

| Rate 1    | Rate 2    | Rate 3    | Rate 4    | Rate 5    |
|-----------|-----------|-----------|-----------|-----------|
| 15-20 kHz | 20-25 kHz | 25-35 kHz | 35-50 kHz | 50-65 kHz |

---

**NOTE.** While you are in custom video mode, the Trigger On Line Number function's range of values is 1 to 3000.

The oscilloscope can display video waveforms for signals with scan rates greater than 65 kHz. However, the waveform data (such as line count) may not be accurate because the oscilloscope is triggering on the next-detected sync pulse. The oscilloscope may miss some sync pulses when scan rates are greater than 65 kHz.

---

## New Apps > 601 Module Menu

The 601 Digital Video module adds a new selection (ITU-R 601) to the Utility > System > Apps > Module menu. The following table describes the new menu functions. Most of these functions are available in the video QuickMenu.

| Bottom  | Side            | Description   |
|---------|-----------------|---|
| Input   | Auto Detect     | Sets the module to automatically detect and trigger on a 525 or 625 video standard signal.  |
|         | 525<br>625      | Sets the module to decode and trigger on either 525 or 625 video waveforms.   |
| Autoset | Lines<br>Fields | Automatically displays a video graticule and adjusts the vertical, horizontal, and video trigger settings to display a video waveform triggered on all lines or all fields. |

| Bottom             | Side               | Description   |
|--------------------|--------------------|---|
| Autoset<br>(cont.) | YPbPr<br>RGB<br>YC | Automatically adjusts the vertical, horizontal, and video trigger settings to display the selected component waveforms. Each menu item lists which component signal is connected to which oscilloscope channel. |
| Error<br>Detection | On<br>Off          | Turns on or off detecting and counting EDH signal errors.   |
|                    | EDH<br>Detected    | Status readout that indicates if an error detection handling (EDH) signal is present in the 601-encoded data.   |
|                    | Errors             | Status readout that lists the total number of EDH errors.   |
|                    | Set to 0           | Resets the error count to zero.   |

## New Functions in the Display Menu

The 601 Digital Video module adds the following functions to the DISPLAY menu. All of these functions are available in the video QuickMenu.

| Bottom    | Side         | Description  |
|-----------|--------------|--|
| Graticule | IRE<br>(new) | Displays an IRE measurement graticule and sets the vertical scale to 143 mV/div.       |
|           | mV<br>(new)  | Displays a mV measurement graticule and sets the channel vertical scale to 143 mV/div. |

| Bottom                    | Side                    | Description   |
|---------------------------|-------------------------|---|
| Video<br>Picture<br>(new) | Picture<br>On Off       | Turns on or off displaying a 4:3 ratio mono-chrome picture of the luminance or composite video signal connected to channel 1. Use this function to verify the signal source.  |
|                           | Auto Contrast<br>On Off | Turns on or off automatic contrast adjustment for the Video Picture mode. The Contrast and Brightness menu items are not selectable when Auto Contrast is On.   |
|                           | Contrast                | Adjusts the video picture contrast from 0 (minimum) to 100 (maximum). The default value is 54.  |
|                           | Brightness              | Adjusts the video picture brightness from 0 (minimum) to 100 (maximum). The default value is 41.  |
|                           | Line<br>Number          | <p>Displays the current video trigger line number (and even/odd field value for NTSC). This value corresponds to the position of the horizontal line drawn on the picture.</p> <p>You can use the general purpose knob to change these values. You can also push the side menu button to toggle between even and odd line numbers for NTSC signals.</p> |

| Bottom             | Side                                  | Description  |
|--------------------|---------------------------------------|--|
| Vector-scope (new) | Off                                   | Turns off vectorscope display format.  |
|                    | Ch <i>N</i> vs Ch <i>N</i> (Pb vs Pr) | Turns on the vectorscope display format. The menu item shows which component signal connects to which input channel, where <i>N</i> is the oscilloscope channel. The input channels are not user-selectable. |
|                    | Color Bars                            | Sets vectorscope display for 75% or 100% color bars.   |

### Key Points

**IRE and mV Graticules.** Both graticules include labeled graticule marks that are useful for measuring component signals. Also, Hbar-cursor values are shown in IRE units when the IRE graticule is active.

---

**NOTE.** Changing from the IRE or mV graticule to any other graticule style does not reset the volts/division scale from 143 mV. Use the Vertical SCALE knob to change the volts/division setting when changing to a non-video graticule.

---

**Video Picture.** Video Picture mode does not display a picture for SECAM, Custom, or analog HDTV signals. Also, many of the oscilloscope controls are disabled while in Video Picture mode.

The default Video Picture contrast and brightness settings correspond to a black level of 7 IRE and a white level of 100 IRE.



The Video Picture mode draws a bright horizontal line on the picture. This line-select cursor lets you visually select the Video Picture line on which to trigger. Select **Line** in the Field/Line trigger side menu and use the general purpose knob to move the line-select cursor to set the video line.

The oscilloscope draws the picture using either even or odd fields of data, based on the current field/line trigger setting when Video Picture is turned on. Changes to the field/line trigger settings do not change the video picture until the next time Video Picture is turned on. The following table lists which fields are used to draw the picture for each field/line trigger setting.

| Field/Line setting                            | Fields used to draw the video picture |
|---|---------------------------------------|
| Even, Even-numbered line                      | Even                                  |
| Odd, All Fields, All Lines, Odd-numbered line | Odd                                   |

## Changes to the Acquire Menu

The 601 Digital Video application module adds the following side menu item to the Acquire Autoset menu.

| Side menu     | Description  |
|---------------|--|
| Video Autoset | Executes the video autoset function to automatically display a mV video graticule with video waveforms triggered on all lines. |

## Application Examples

The following are some examples of how to use the 601 video module to acquire and display various video signals. All these examples assume that you have connected the 601 Digital Video module cables to the correct input channels.

### Example 1: Video Picture

In this example, you want to quickly identify an ITU-R 601 video signal. To do this you need to display a picture of the signal. Do these steps:

1. Connect the 601 video signal to the input of the module.
2. Push the **QuickMenu** button.
3. Push the **MENU** bottom button to select **Video**.
4. Push the **SUBMENU** bottom button to select **ITU-R 601**.
5. Push the **INPUT** side button to select **Auto Detect**.
6. Push the **AUTOSET Lines/Fields** bottom button to trigger on and display a video signal.
7. Push the **Picture** bottom button to turn Video Picture mode **On**. The picture displays in the center of the graticule area.

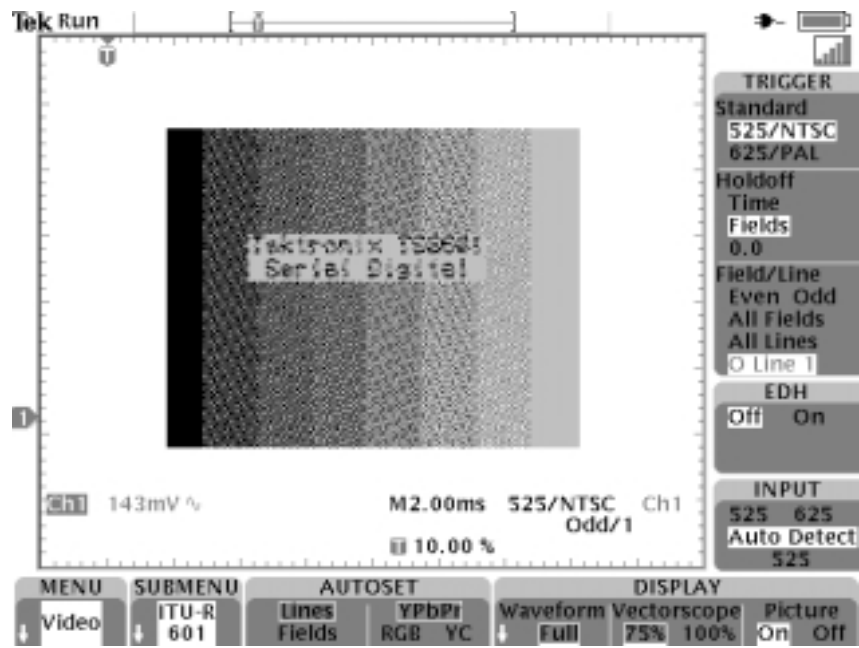

### Example 2: Viewing 601 Component Signals

Continuing from example 1, you want to set the oscilloscope to trigger on a particular line that is in an area of interest on the Video Picture. Do these steps while in Video Picture mode:

1. Push the **Field/Line** side menu button to select Line.
2. Use the general purpose knob to position the horizontal line into the area of interest. This sets the oscilloscope Field/Line trigger value to the field and line at the position of the picture line.

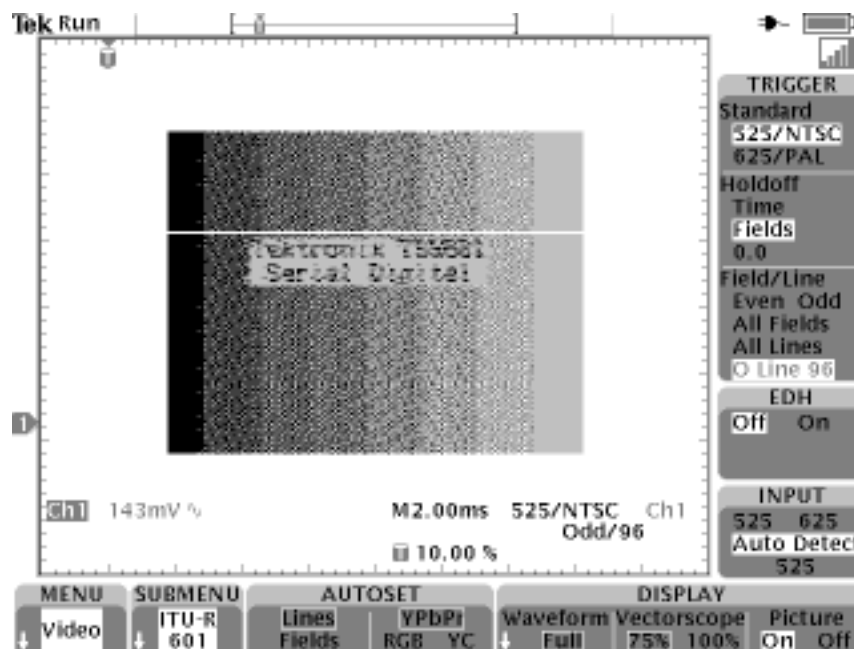

3. Push the **Picture** button to turn Video Picture mode Off.

4. Push the **AUTOSET** bottom menu button to select the component format (YPbPr, RGB, or YC). The oscilloscope displays the component signals.

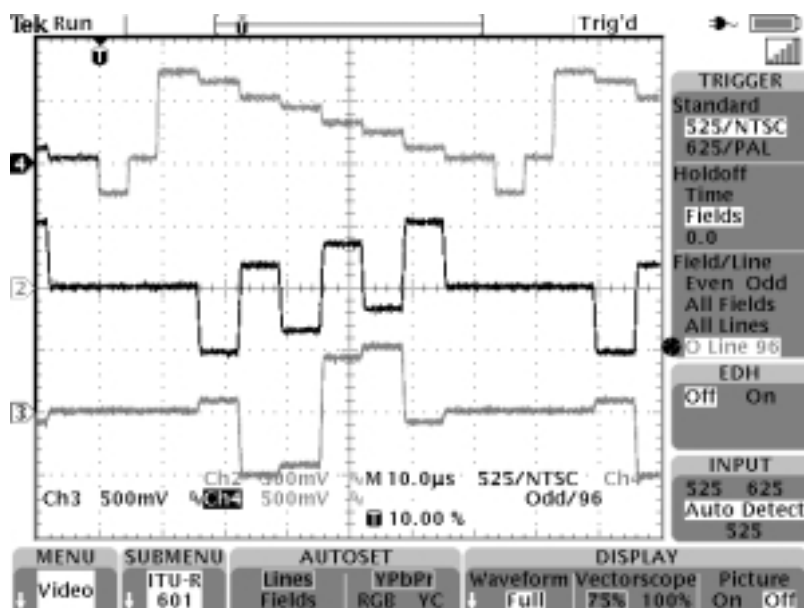

### Example 3: Vectorscope

Continuing from example 2, you now need a vectorscope display to quickly verify the color relationship for a 75% color bar signal. Do these steps:

1. Push the **DISPLAY Vectorscope** button to enable the Vectorscope. The oscilloscope displays the vectorscope screen.
2. If necessary, push the **DISPLAY Vectorscope** button again to select **75%**.

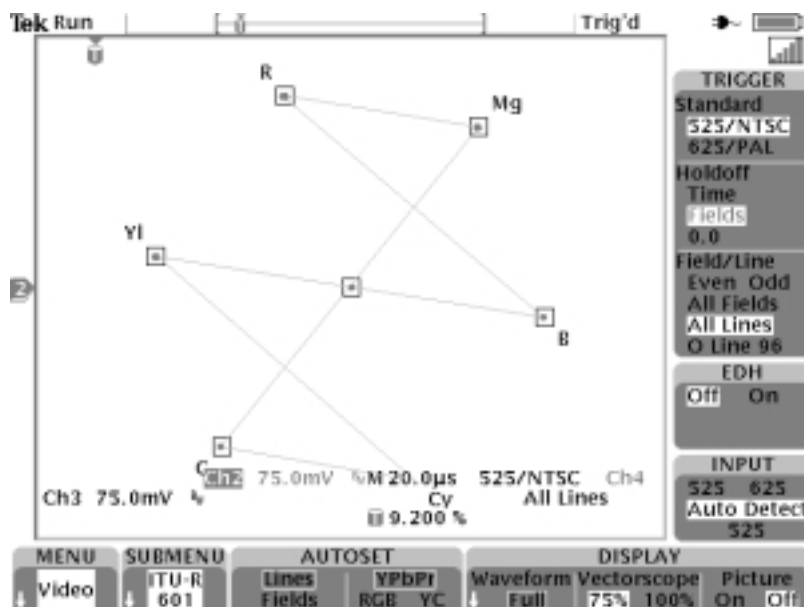

3. To return to the component signal or picture mode, push the corresponding AUTOSSET or DISPLAY bottom button.

**Example 4: Video Autoset**

In this example, you are trying to troubleshoot where a composite broadcast video signal is getting lost in the master control feed. You need to quickly acquire a waveform at different test points. Do these steps:

1. Connect the composite video signal to oscilloscope channel 1 using proper adapters and a 75 ohm terminator.
2. Push the Acquire **MENU** button.
3. Push the **Autoset** bottom button.
4. Push the **Video Autoset** side button. If a broadcast-standard video waveform is present, the oscilloscope displays a stable video waveform that is triggered on all lines.
5. Connect the oscilloscope to the other test points until you locate where the signal is lost. You do not need to change any oscilloscope settings.

### Example 5: Trigger On Line

In this example, you suspect that one or more pixels are defective in a Charge-Coupled Device (CCD) video camera. You need to determine which line in which fields contain the defective pixel(s). Do these steps:

1. Connect the video camera output signal to oscilloscope channel 1 using proper adapters and a 75 ohm terminator.
2. Cover the camera lens with a lens cover so that no light enters the lens.
3. Push the **QUICKMENU** button to display the QuickMenu.
4. If the video QuickMenu is not displayed, push the **MENU** bottom button to display the video QuickMenu.
5. Push the **SUBMENU** bottom button to select **SDTV/HDTV**.
6. Push the **Format** side button to select **SDTV**.
7. Push the **AUTOSET** bottom button to select **Lines**.
8. Push the **ACQUIRE** bottom button to select **Normal**; this increases the waveform resolution.
9. Push the **Field/Line** side button to select **O Line n** (odd) or **E Line n** (even) for 525/NTSC signals, or **Line n** for 625/PAL and SECAM signals. Use the general purpose knob to select the video signal line on which to trigger.
10. Rotate the general purpose knob to examine each video line. Write down the line number (and field if applicable) of any waveforms with pixels that exceed error specifications. You can also use the Zoom function to magnify the line display and determine the number of defective pixels in a line.



**Example 6: Custom Video**

In this example, you need to display a composite video waveform from a medical instrument display driver that uses a non-broadcast scan rate of 50 kHz. Do these steps to display the waveform:

1. Connect the composite video signal to oscilloscope channel 1 using proper adapters and a 75 ohm terminator.
2. Push the Trigger **MENU** front panel button.
3. Push the **TYPE** bottom button to select **Video**.
4. Push the **Standard** bottom button to select **Custom**.
5. Push the **Source** bottom button to display the A Trigger Source side menu.
6. Push the **CH 1** side button.
7. Push the **Trigger On** bottom button and side menu to set the video trigger condition.
8. Push the **Scan Rate** bottom button to display the scan rate side menu.
9. Push the **Rate 4** side button to select a 35-50 kHz horizontal scan rate. The oscilloscope displays the video waveform.

---

***NOTE.** The oscilloscope will display video waveforms for signals with scan rates greater than 65 kHz. However, the waveform data (such as line count) may not be accurate because the oscilloscope is triggering on the next-detected sync pulse. The oscilloscope may miss some sync pulses when scan rates are greater than 65 kHz.*

---

### Example 7: Holdoff Fields

In this example, you are examining a 525/NTSC composite video waveform from a 601 digital video signal. You need to examine the colorburst signal of field 1 without mixing it with the out-of-phase colorburst signal of field 3. Do these steps:

1. Push the **QUICKMENU** button to display the QuickMenu.
2. If the video QuickMenu is not displayed, push the **MENU** bottom button to select **Video**.
3. Push the **SUBMENU** bottom button to select **ITU-R 601**.
4. Push the **INPUT** side button to select **525**.
5. Push the **AUTOSET Video** bottom button to select **Lines**.
6. Set the horizontal scale to 1.00  $\mu$ s.
7. Use the **HORIZONTAL POSITION** knob to position the colorburst signal toward the center of the screen.
8. Push the **Field/Line** side button to select **O Line  $n$** , where  $n$  represents the current value of the line argument.
9. Rotate the general purpose knob to set the line number to the first colorburst line, which for NTSC signals is line ten.
10. Push the **Holdoff** side button to select **Fields**. This menu lets you specify the number of video fields to skip before re-arming the video trigger.
11. Rotate the general purpose knob to set the number of holdoff fields to 2.5.

12. Determine which field you are triggering on. If necessary, use the Zoom button to magnify the colorburst signal.

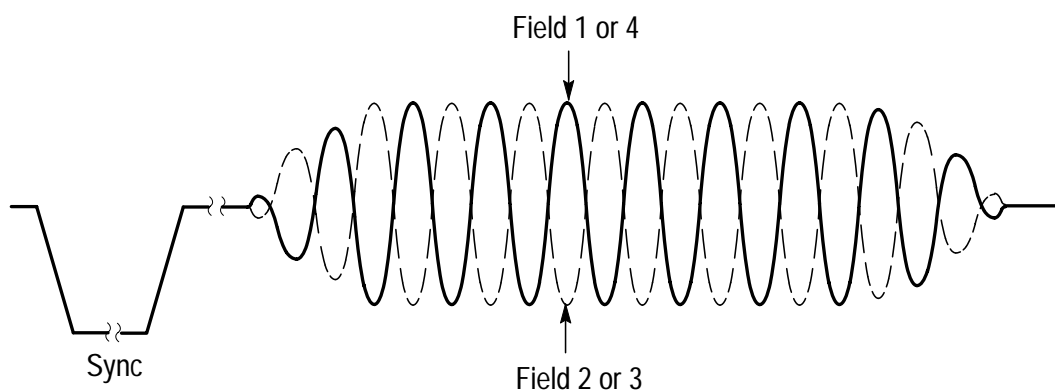

13. If the oscilloscope is triggering on field 2, repeatedly push the **SINGLE SEQ** button until the colorburst waveform changes to the correct phase for field 1, and then push the **RUN/STOP** button to resume triggering the oscilloscope.



# Appendix A: Specifications

This section describes the TDS3SDI 601 Digital Video application module specifications. All specifications are guaranteed unless labeled 'typical.' Typical specifications are provided for your convenience but are not guaranteed.

**Table 1: Specifications**

| Characteristic  | Description  |          |
|---|--|----------|
| Input signal  | 270 Mb/s; complies with ITU-R BT.601-5 and SMPTE 259M.       |          |
| Input impedance   | 75 Ohms $\pm$ 3% DC, single-ended terminated.                |          |
| Output impedance  | 75 Ohms, nominal (output levels set for double termination). |          |
| Return loss   | Minimum 15 dB measured at 135 MHz.                           |          |
| Signal accuracy, typical (signals to oscilloscope input channels) | Ch 1: Composite  | $\pm$ 6% |
|   | Ch 2: Pb (Blue)  | $\pm$ 3% |
|   | Ch 3: Pr (Red or Chrominance)                                | $\pm$ 3% |
|   | Ch 4: Y (Green)  | $\pm$ 6% |
|   | Sync on R, G & B   |          |

**Table 1: Specifications (cont.)**

| Characteristic                    | Description  |                 |
|-----------------------------------|--|-----------------|
| Vectorscope                       | <i>Description</i>   | <i>Accuracy</i> |
| Accuracy, typical                 | 525 (NTSC) and 625 (PAL) signals   | ±3%             |
| Target box size                   | 3% from center to any edge.  |                 |
| Cable equalization range, typical | Up to 250 meters of Belden 8281 cable or equivalent.   |                 |
| Picture mode                      | Monochrome, compressed video image in 4:3 format.  |                 |
| Video error detection             | EDH (Error Detection and Handling) per SMPTE RP165.  |                 |
| Environmental, Mechanical and EMI | Refer to the TDS3000 Series instrument specifications for environmental, mechanical, and EMI specifications. |                 |