

Instructions



Option 1R Rackmount Kit TDS5000B Series Digital Phosphor Oscilloscopes 071-1421-01

Warning

The servicing instructions are for use by qualified personnel only. To avoid personal injury, do not perform any servicing unless you are qualified to do so. Refer to all safety summaries prior to performing service.

www.tektronix.com



071142101

Copyright © Tektronix. All rights reserved. Licensed software products are owned by Tektronix or its subsidiaries or suppliers, and are protected by national copyright laws and international treaty provisions.

Tektronix products are covered by U.S. and foreign patents, issued and pending. Information in this publication supercedes that in all previously published material. Specifications and price change privileges reserved.

TEKTRONIX and TEK are registered trademarks of Tektronix, Inc.

Contacting Tektronix

Tektronix, Inc.
14200 SW Karl Braun Drive
P.O. Box 500
Beaverton, OR 97077
USA

For product information, sales, service, and technical support:

- In North America, call 1-800-833-9200.
- Worldwide, visit www.tektronix.com to find contacts in your area.

Service Safety Summary

Only qualified personnel should perform service procedures. Read this *Service Safety Summary* and the *General Safety Summary* in the product service manual or the instruction manual.

Do Not Service Alone. Do not perform internal service or adjustments of this product unless another person capable of rendering first aid and resuscitation is present.

To prevent the instrument and rack from falling onto the operator, two or more installers should install the instrument into the rack cabinet. After completing the installation procedure, the installers should verify that the instrument and rack cabinet will not tip forward while the instrument is in the extended position.

Disconnect Power. To avoid electric shock, switch off the instrument power, then disconnect the power cord from the mains power.

Use Care When Servicing With Power On. Dangerous voltages or currents may exist in this product. Disconnect power and disconnect test leads before removing protective panels, soldering, or replacing components.

To avoid electric shock, do not touch exposed connections.

Kit Description

This introduction describes the installation of the rackmount kit to your standard bench-top instrument.

The rackmount kit is a collection of parts that, once installed, configure the instrument for mounting into a standard 19-inch equipment rack.

Products

TDS5000B Series All Serial Numbers

Kit Parts List

Figure 1 on page 4	Quantity	Part number	Description
-----	1 ea	016-1887-XX	RACKMOUNT KIT TDS5000B SERIES CONSISTING OF THE FOLLOWING:
-----	1 ea	071-1421-01	TECH MANUAL: INSTRUCTIONS, TDS5000B SERIES
1-1	1 ea	386-7301-00	RACKMOUNT PANEL LEFT
1-2	1 ea	386-7302-00	RACKMOUNT PANEL RIGHT
1-3	4 ea	NS	SCREW, MACH: 10-32, PAN-HEAD, 0.5 IN I, PHILLIPS
1-3	7 ea	NS	NUT, LOCKING WASHER: 10-32 ASSEM
1-3	20 ea	NS	SCREW, MACH: 10-32, TRUSS-HEAD, 0.375 IN I, PHILLIPS
1-3	4 ea	NS	SCREW, MACH: M6 x 20 OVAL-HEAD, PHILLIPS
1-3	4 ea	NS	SCREW, MACH: M5 x 20 OVAL-HEAD, PHILLIPS
1-3	4 ea	NS	SCREW, MACH: 10-32 x 0.75 OVAL-HEAD, PHILLIPS
1-3	4 ea	NS	SCREW, MACH: 12-32 x 0.75 OVAL-HEAD, PHILLIPS
1-3	5 ea	NS	WASHER: FLAT, NYLON
1-4	2 ea	351-1095-00	SLIDE, DRAWER, EXTENDERS: SLIDERS
1-4	2 ea	NS	RACK: MOUNTING SCREWS, NUT BLOCKS
1-5	1 ea	200-4866-00	COSMETIC COVER, RACKMOUNT
1-6	1 ea	386-7340-00	PLATE: SHEET METAL, GUARD BRACKET

Figure 1 on page 4	Quantity	Part number	Description
1-7	1 ea	386-7300-00	PLATE: STEEL, BRACKET SPACER
1-8	2 ea	367-0525-00	HANDLE: BRACKET, AL, GRAY

NS - Not Saleable

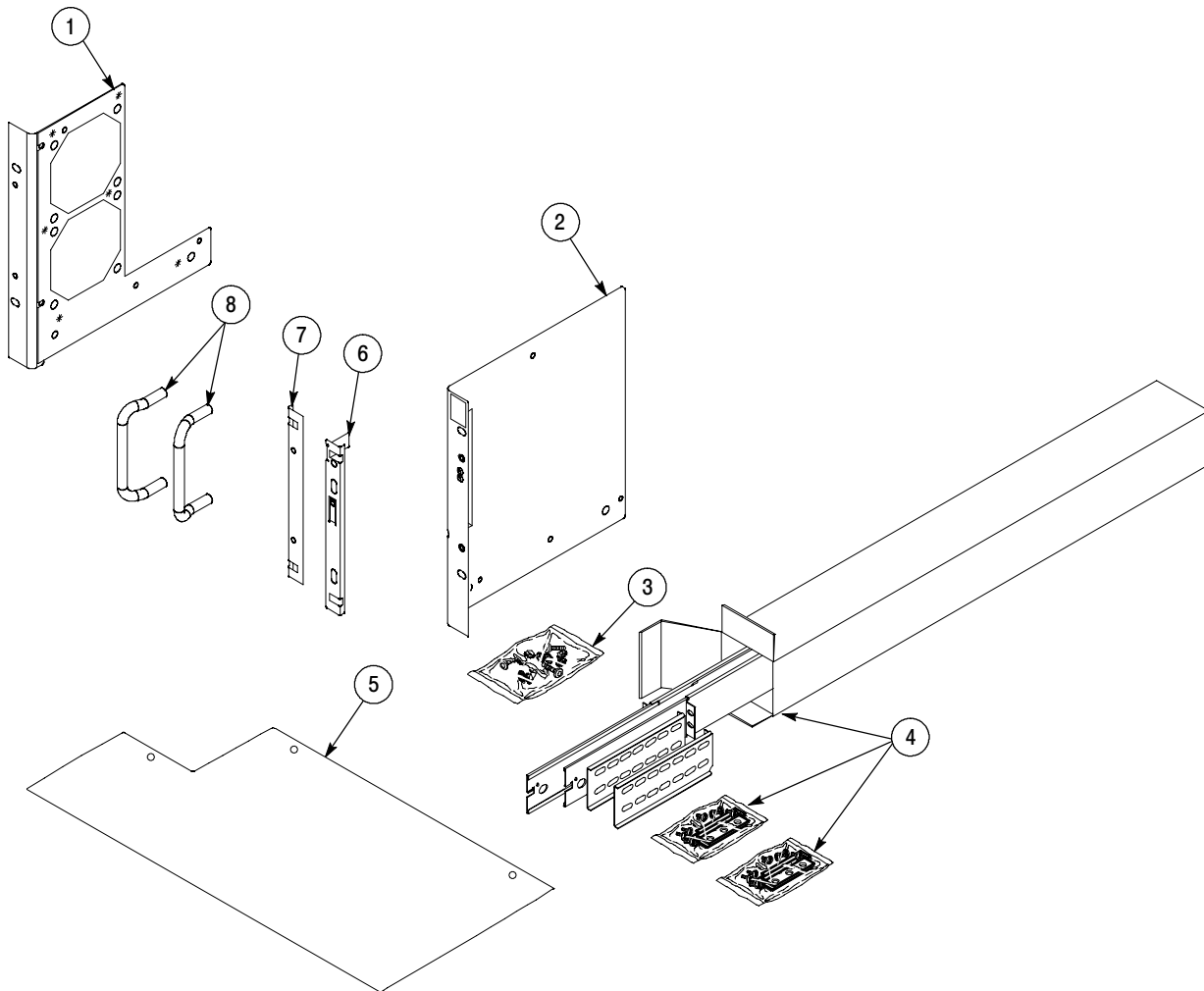

Figure 1: Rackmount kit parts

Warranted Characteristics

When the instrument is installed according to the instructions in this document, the rackmounted instrument meets all warranted requirements listed in the instrument specification except for those listed in *Environmental Requirements* on page 6. Instruments mounted using methods other than those described in these instructions may not meet their warranted requirements.

See the specifications for your instrument model for tables of the warranted characteristics.

Cooling air enters on the bottom and right sides as shown in Figure 2. You must provide adequate cool air to meet the ambient temperature requirements listed in Table 1.

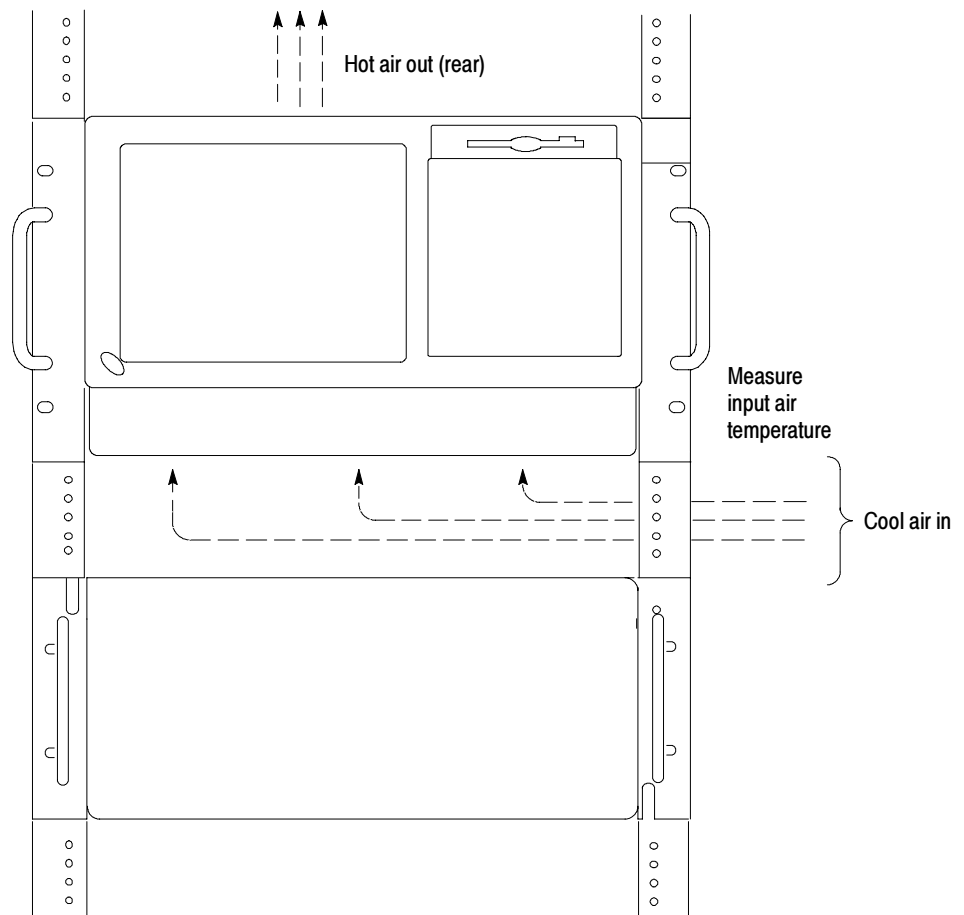

Figure 2: Instrument cooling

Environmental Requirements

The following environmental characteristics supercede those listed in the specifications and performance verification sections of the manual for your instrument.

Table 1: Warranted characteristics

Characteristic	Description
Temperature, Inside Rack Cabinet	
Operating	+10 °C to +45 °C (+50 °F to +113 °F)
Non-operating	-22 °C to +60 °C (- 7.6 °F to +140 °F)
Shock	
Operating and Non-operating	20 g, 11 ms, half sine, each axis, 3 drops each

Clearance Requirements

The rack in which the rack adapted instrument is mounted must provide the following clearance requirements:

- A minimum of 10.5 inches (266.7 mm) of vertical space.
- A minimum width of 17 5/8 inches (448 mm) between the left- and right-front rails in the rack.
- A minimum depth of 20 inches (508 mm).



CAUTION. *Adhering to these clearance requirements provides the rack-mounted instrument with sufficient clearance for air circulation and accommodation of the power cord and mounting hardware. Failure to provide these clearances can result in overheating and can cause instrument faults or failure.*

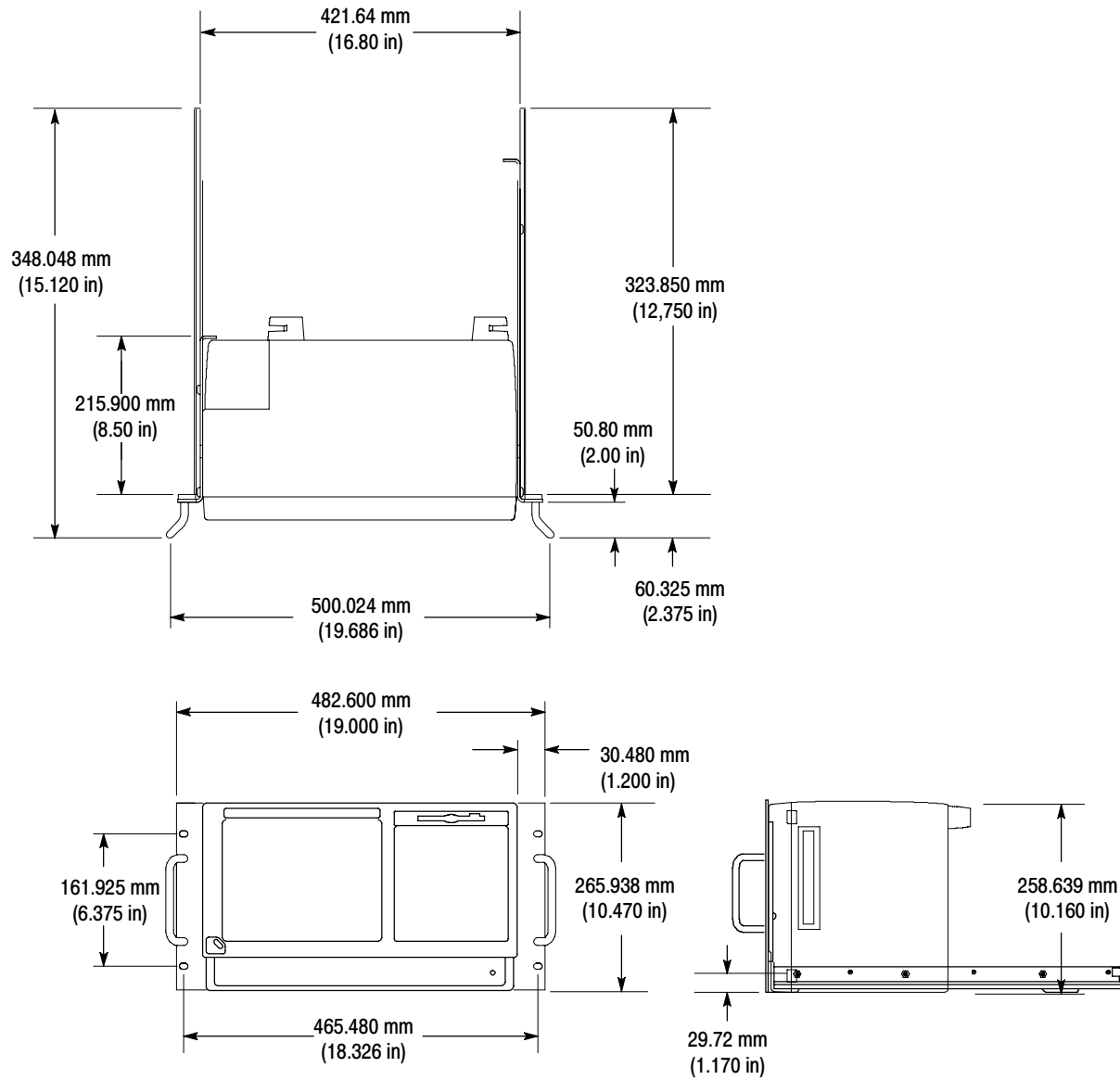

Figure 3: Instrument with rack adapter installed

Installation Instructions

This section contains all procedures needed to rackmount the TDS5000B.

Minimum Tool and Equipment List

The following tools are required to attach the rack-adapter kit hardware, install cabling hardware, and mount the rack-adapted instrument into a standard equipment cabinet. All tools are standard tools that are readily available.

Table 2: Tools required for rackmount installation

Item no.	Name	Description
1	Screwdriver handle (magnetic)	Accepts 1/4-inch hexagonal head driver tips
2	No. 2 Phillips or PoziDriv tip	Phillips or PoziDriv-driver tip for number 2 size screw heads
3	T-15 Torx tip	Torx-driver tip for T-15 size screw heads
4	1/4-inch wrench	Wrench or nut driver can be used to install slides
5	Torque driver	Accepts 1/4-inch hexagonal head driver tips
6	1/8 inch flat-bladed screwdriver	Screwdriver can be used to remove the CD drive trim

These instructions are for qualified service personnel who are familiar with servicing the product. If you need further details for disassembling or reassembling the product, refer to the appropriate product manual. Contact your nearest Tektronix Service Center or Tektronix Factory Service for installation assistance.



WARNING. *To prevent the rackmounted instrument from tipping forward onto the operator, install the instrument so that the operator will be able to access all of its rear-panel connectors without pushing down on the instrument.*

Verify that the rack does not become unstable with the instrument fully extended. Do not leave the instrument extended when finished accessing the rear panel.

Remove

Strip the Instrument for Conversion

Equipment Required: Screwdriver handle with T-15 tip and flat-bladed screwdriver (Items 1, 3 and 6).

NOTE. *Retain all parts removed from the instrument for later use. Some of those parts will be reinstalled as you perform this rack conversion; store the remainder in case reconversion to a standard instrument configuration is desired at a later time.*

1. Remove the line cord.
2. Remove the two top feet/line cord holders.
3. Remove the accessory pouch and mounting bracket.
4. If the printer or accessory tray are installed, remove the two T-15 Torx screws that secure them to the chassis. If printer or accessory tray is not installed, skip to step 7.
5. If you are removing the printer, disconnect the cable from the printer.
6. Remove the printer or accessory tray from the instrument.
7. Remove the plastic top cover by pulling it towards the rear of the instrument.
8. Remove the CD drive trim from the right side of the instrument, using a 1/8 inch flat-bladed screwdriver.
9. Remove three T-15 Torx screws from the top of the instrument, which enables the metal cosmetic rackmount top cover to be installed. Refer to Figure 8 on page 15.
10. Remove two T-15 Torx screws that secure the right-side cover, then slide the cover toward the rear of the instrument to remove it.
11. Remove the two T-15 Torx screws that secure the carrying handle to the left-side cover and remove the carrying handle.
12. Remove the two T-15 Torx screws that secure the left-side cover, then slide the cover toward the rear of the instrument to remove it.
13. Remove the two T-15 Torx screws that secure the bottom cosmetic cover to the instrument. Remove the bottom cosmetic cover from the instrument.
14. Remove the plastic VGA panel from the instrument.

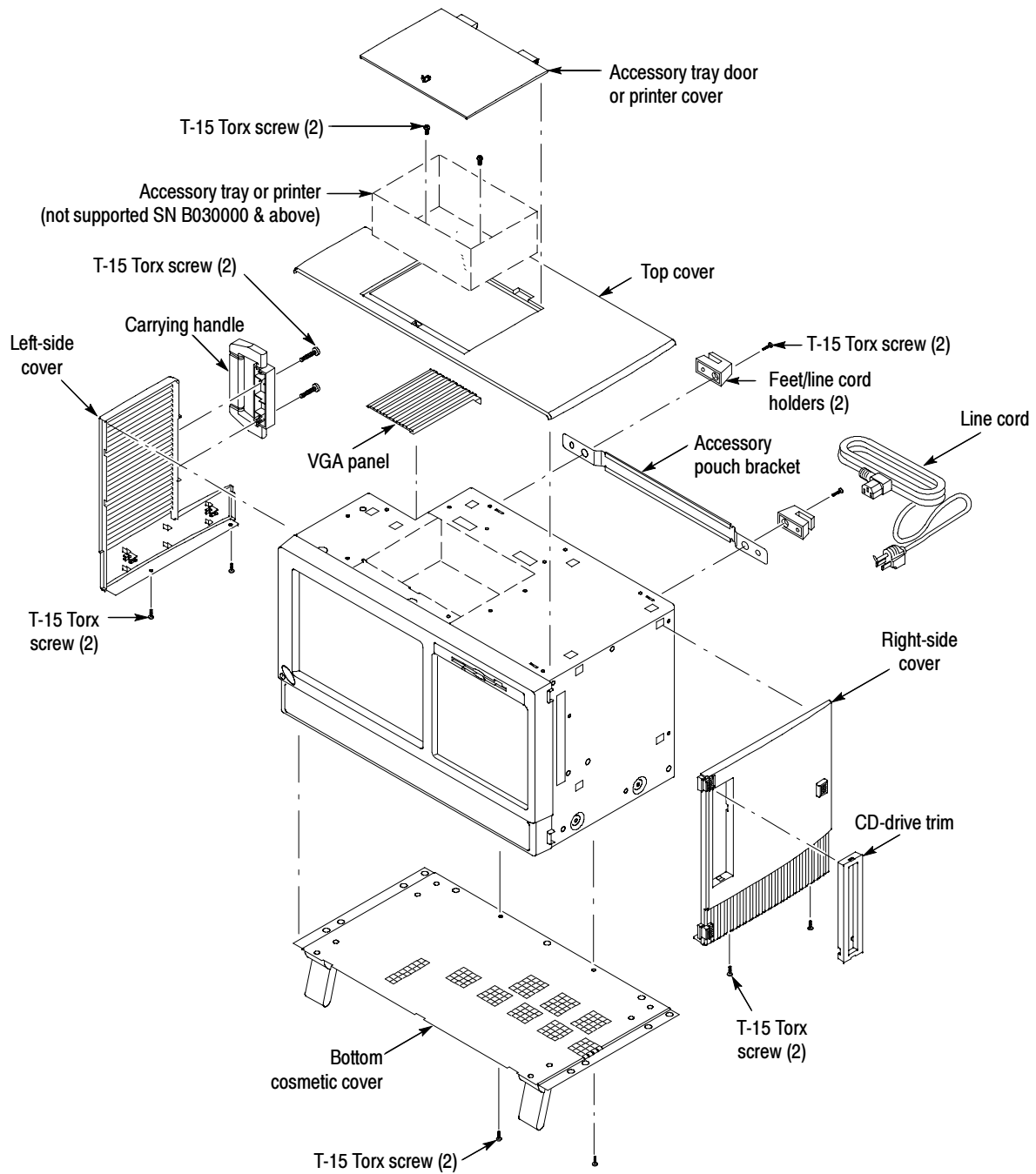

Figure 4: Strip instrument for conversion

Install

Equipment Required: Torque driver with T-15 tip (Items 5 and 3).

This section describes mounting the rackmount parts to the instrument.

1. Remove the front section of each of the two tracks. See Figure 5.

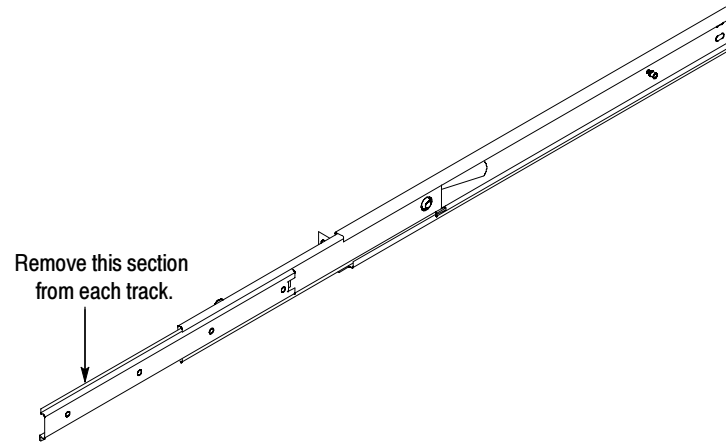

Figure 5: Prepare tracks for mounting

NOTE. Assemble all subparts on the right and left-side panels before installing the rackmount panels on the instrument. Refer to Figure 6.

2. Install the bracket handle and bracket/guard to the right-side rackmount panel. Secure by using the two 10-32 pan-head, Phillips screws, applying 15 inch-lbs of torque. Refer to Figure 6 on page 13.

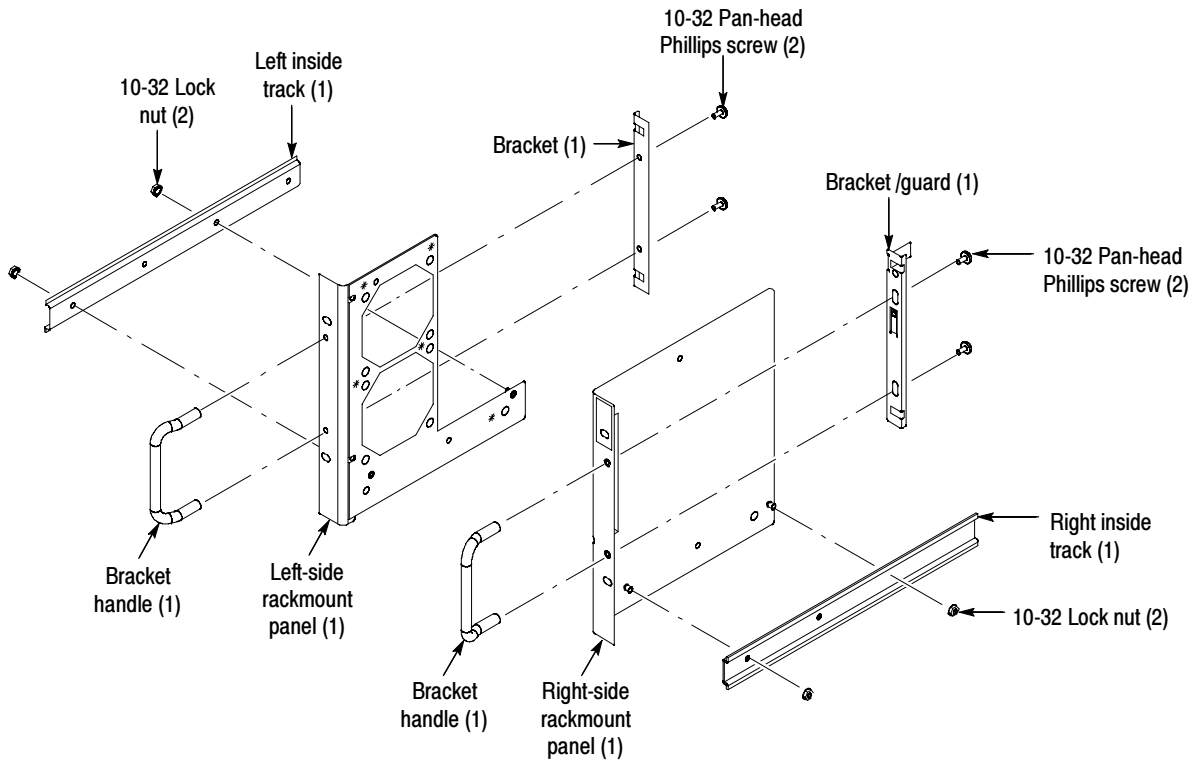

Figure 6: Rackmount panel preassembly

3. Install the right-side rackmount track (the tracks are interchangeable) over the two screw posts on the right-side rackmount panel. Use two 10-32 locking-nut washer assemblies to secure the track onto the rackmount panel, applying 28 inch-lbs of torque.



WARNING. To avoid Injury or death, ensure that the rackmount track locks. Check that the track button latches are oriented correctly: the right-side latch is located toward the bottom of the rackmount panel and the left-side latch is located toward the top of the rackmount panel. Refer to Figure 7 on page 14.

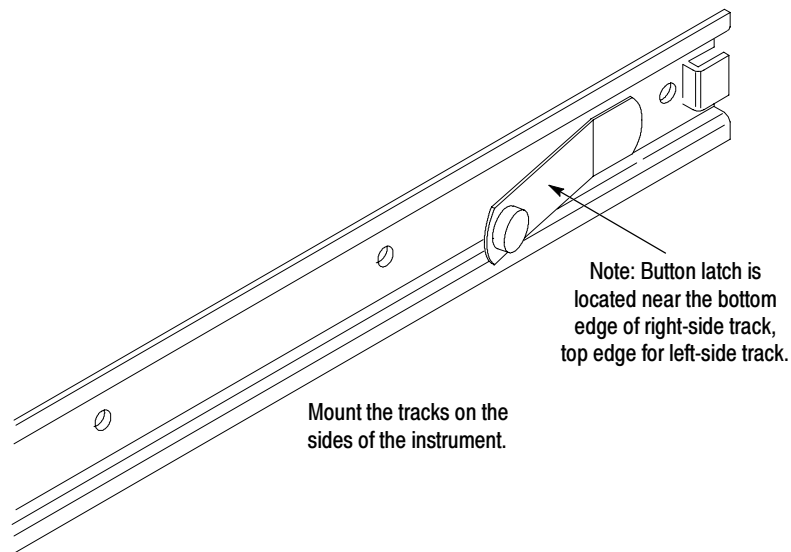

Figure 7: Track orientation

4. Install the right-side rackmount panel assembly to the right side of the instrument. Secure it by using the four 10-32 Truss-head Phillips screws, applying 28 inch-lbs of torque. Refer to Figure 8 on page 15.
5. Repeat steps 2 through 4 to install the left-side rackmount panel assembly, using the remaining left-side components.
6. Use a T-15 Torx screw to fill the screw hole under the plastic VGA panel.
7. If desired, install the cosmetic top cover using three Torx screws from the instrument. See Figure 8 on page 15.
8. Reinstall the two top feet/line cord holders.

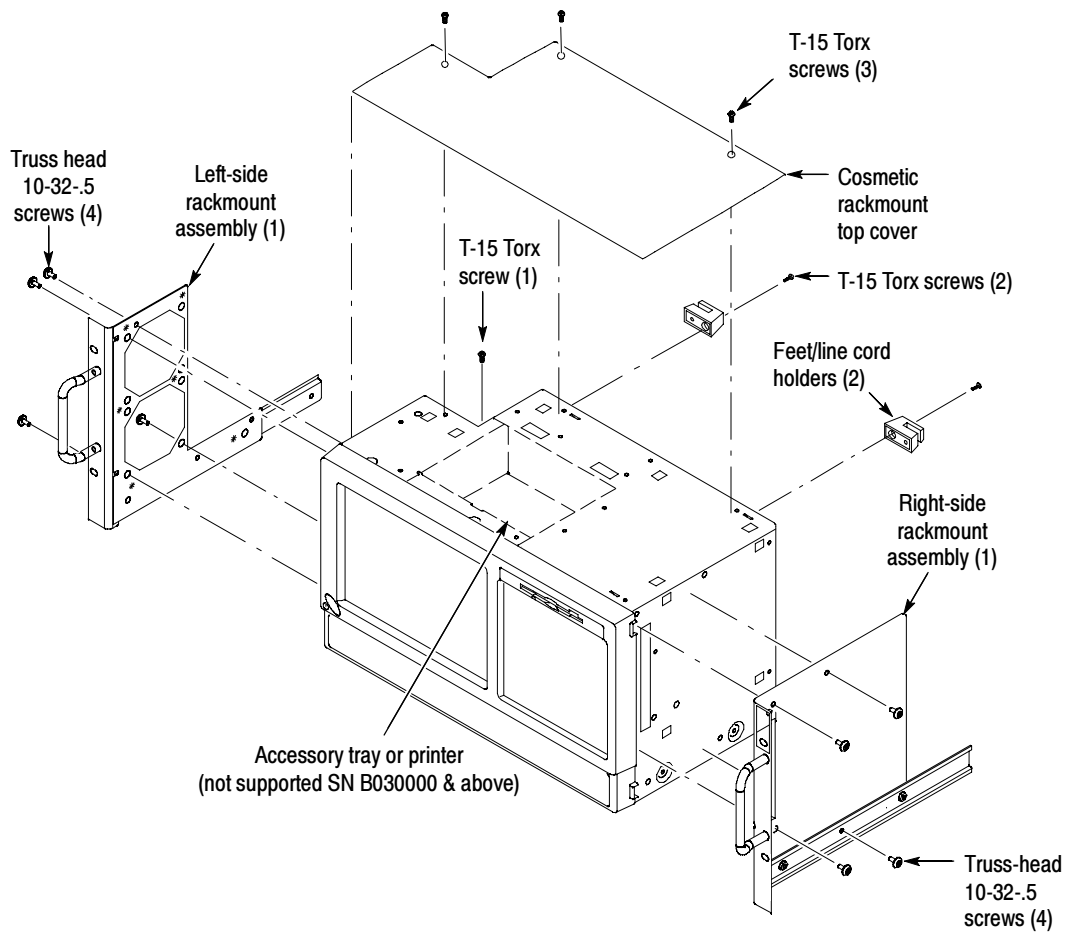

Figure 8: Installation of rackmount assemblies

This completes the installation of the rack-adapter hardware to the instrument. To complete the installation, do the following procedure: *Rackmount the Rack-Adapted Instrument.*

Rackmount the Rack-Adapted Instrument

This procedure assembles and installs the slide-out tracks in the equipment rack, and then installs the rack-adapted instrument in the rack.

The slide-out tracks permit the rack-adapted instrument to be extended out of the rack for rear-panel and connector maintenance without removing the instrument from the rack.



WARNING. *To prevent the rackmounted instrument from tipping forward onto the operator, install the instrument so that the operator will be able to access all of its rear devices without pushing down on the instrument.*

Verify that the rack does not become unstable with the instrument fully extended. Do not leave the instrument extended when finished accessing the rear panel.

**Install Track Assembly
and Instrument into the
Rack**

Equipment Required: One screwdriver handle (Item 1), one number two PoziDriv tip (Item 2), and one torque driver (Item 5).

NOTE. *The rack hardware kit contains hardware for mounting the instrument in several configurations. Not all of the hardware in the kit will be needed.*

A standard equipment rack has rails with universal hole spacing. If you use a rack with other than universal hole spacing, you may have to drill additional mounting holes in the rack.

Procedure:

1. *Assemble the slide-out track:*
 - a. Measure the distance between the front and rear rail of the equipment rack.
 - b. Align the rear bracket to the right slide-out track as shown in Figure 9. Note that the rear bracket has multiple pairs of mount-through holes. When aligning the bracket and track, be sure to select a pair of holes that mount the rear bracket so that the flange-to-flange distance matches the front-rail to rear rail distance measured in step a.
 - c. Using a screwdriver with a number two PoziDriv tip, secure the rear bracket to the right slide-out track using two screws (10-32) and a bar nut as illustrated. Leave the screws loose so that the overall length of the slide-out track assembly can be adjusted when installing it in the rack.
 - d. Repeat steps b and c to assemble the left slide-out track assembly.
2. *Mount the slide-out track assemblies, using the slide drawer hardware listed in the kit parts list, Figure 3-4:*
 - a. *Select the mounting position in rack:* Select two 0.5 inch-spaced holes in the front rail. Verify that the 4.36 inch and 10.500 inch clearances exist relative to those mounting holes. See Figure 10 on page 19.

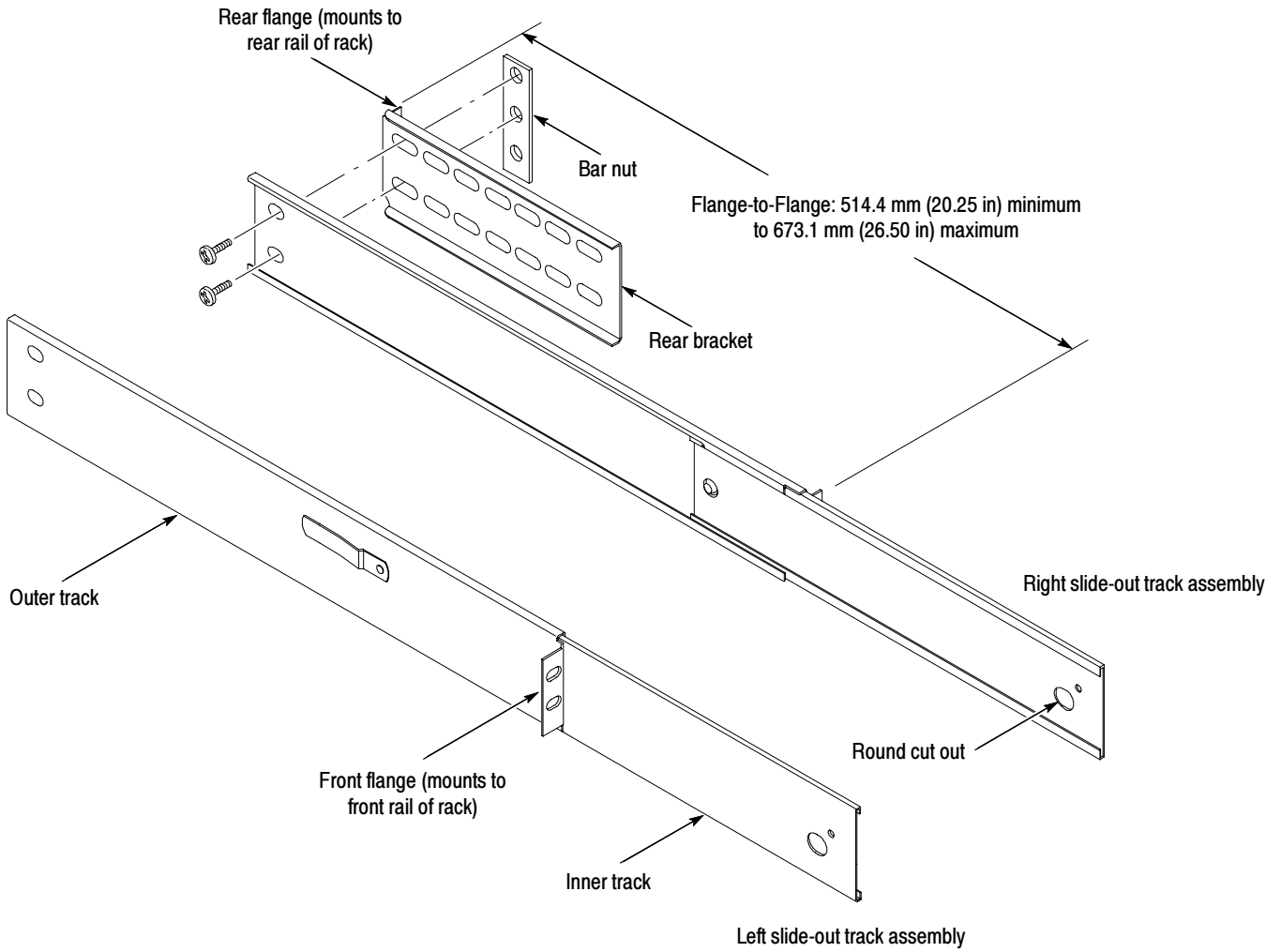

Figure 9: Assembly of slide-out track assemblies

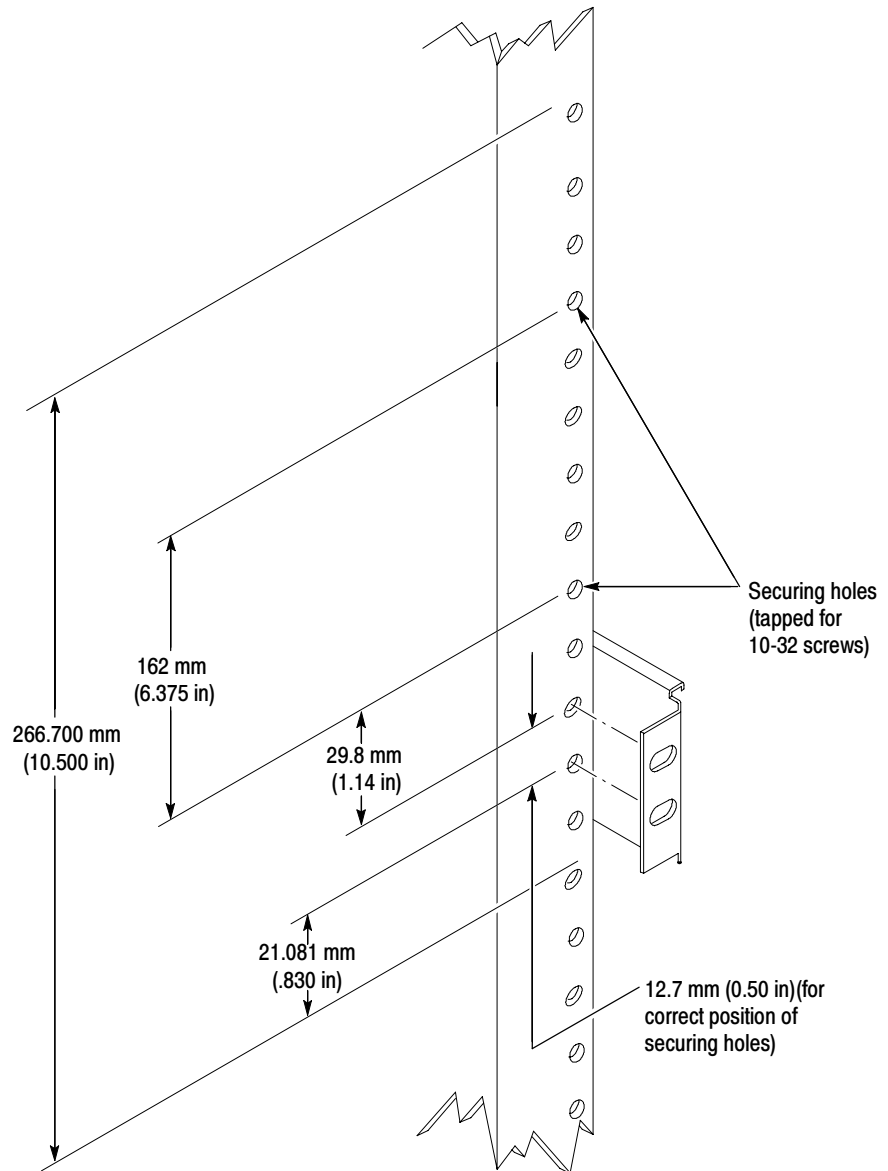

Figure 10: Vertical clearances for rack installation (left-front rail shown)

b. Select mounting method according to rack type:

- To mount the slide-out tracks with their front and rear flanges outside of the front and rear rails, use the mounting method A shown in Figure 11 when doing substep c. Add a bar nut to the installation only if the rails have untapped holes.
- To mount with front and rear flanges inside of rails, use the mounting method B outlined in Figure 11. This mounting method assumes untapped holes.

c. Install in rack: Using the method and hardware determined from substep b, secure the right slide-out track assembly to its front and rear rails. The screws should be fully, but lightly, seated so mounting can be adjusted later.

d. Fix the length of the slide-out track assembly: Tighten the screws, applying 28 inch-lbs of torque, left loose in step 1, substep c to fix the front to rear flange spacing of the slide-out track assembly.

e. Mount the left slide-out track assembly: Repeat substeps a through d to mount the left slide-out track assembly.

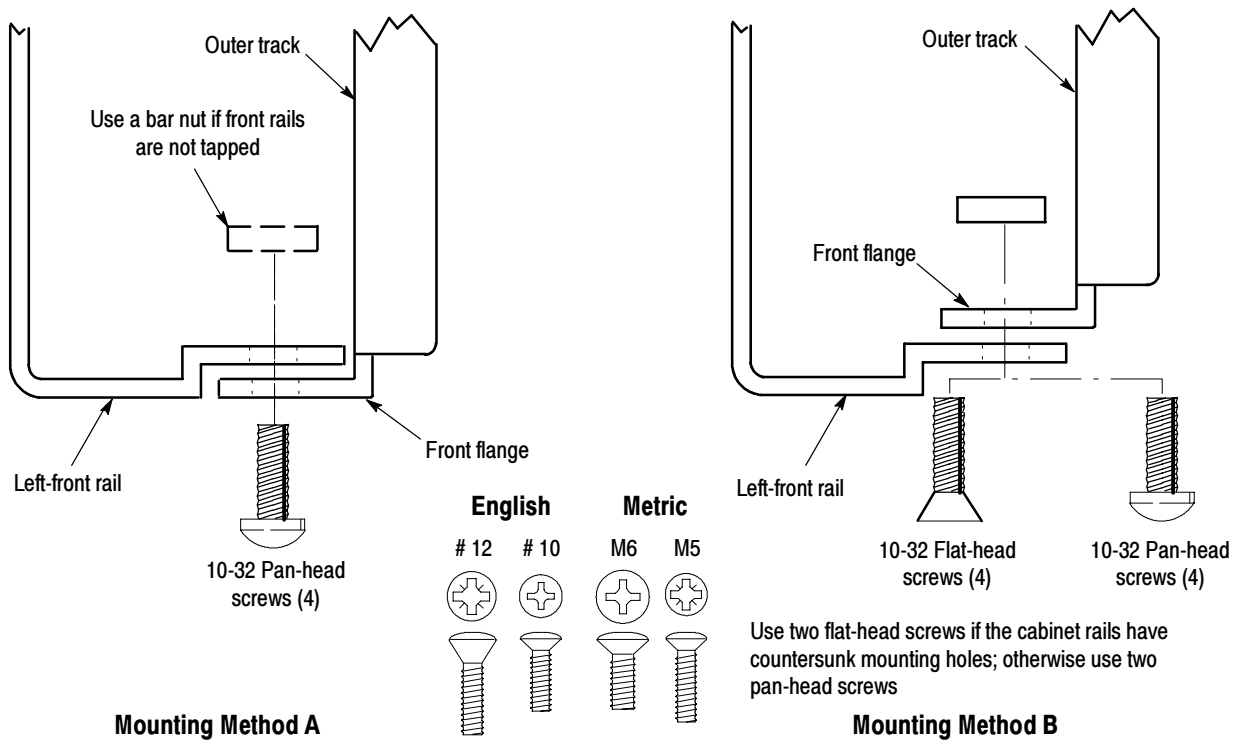

Figure 11: Installation of slide-out track assemblies in rack (top view)

3. Mount the instrument in the rack:



WARNING. To prevent the instrument from tipping or dropping onto the installers, two or more people should install this instrument into the rack cabinet.

After completing the installation procedure, the installers should verify that the instrument and rack cabinet will not tip forward while the instrument is in the extended position.

a. Install the instrument:

- Working from the front of the rack, slide the inner track of each slide-out track assembly until it extends out the front of the rack. Continue to slide them out until they lock.
- Insert the left and right tracks that extend from the rear of the instrument into the tracks that just extended. Make sure the tracks mounted on the instrument slip inside the inner tracks extended earlier.
- Slide the instrument backwards until it stops.
- Push to release the button latches, located on the outside of each track, and continue to slide the instrument all the way into the cabinet.

b. Level the rackmounted instrument:

- Tighten the four screws that were left loose at the rear of the rack when you did step 2, substep c, and then pull the instrument part way out of the rack.
- Be sure that the four screws that were left loose at the front of the rack are loose enough to allow the slide-out track assemblies to seek their normal positions.
- Retighten the four screws and push the instrument all the way into the rack. If the tracks do not slide smoothly, readjust the level using the method just detailed.
- When leveling is completed, tighten the 10-32 screws using 28 inch-lbs of torque.

Finishing the Installation

It is recommended that you secure the instrument to the rack. However, if you expect to be accessing the CD drive or optional internal printer, for convenience, you may decide not to fasten the instrument brackets to the rack. If this is the case, reattach the power cord to complete the installation, and read *Using the CD Guard*.



WARNING. *To prevent the rackmounted instrument from sliding forward and causing personal injury or instrument damage, always secure the instrument to the rack if the rack is moved (for example, if the rack is repositioned or relocated to another room).*

c. *Secure the instrument to the rack:*

- Locate and use one of the following types: 10-32 or 12-24 or M5-20 or M6-20 oval-head screws. Insert each screw through its nylon finish washer as shown on the data sheet included with the hardware kit.
- Using a number two Phillips screwdriver, install the screw/washer assembly in one of the two mounting holes in the left front bracket. Repeat for the second mounting hole. Tighten both screws using 25 inch-lbs of torque.
- Install one of the two remaining screw/washer assemblies in the lower hole of the right-front bracket using the method just described.
- Reinstall the power cord.

Using the CD Guard

Read these instructions to familiarize yourself with using the CD guard.

It is possible to damage the CD drive if it is accessed while the instrument is all the way in the rack. If the CD tray is open, and you attempt to slide the instrument out of the rack, you can break the CD tray. The purpose of the CD guard is to prevent the CD tray from opening when the instrument is installed all the way in the rack. This can only be accomplished by having the guard in the down position.



CAUTION. *To prevent damage to the instrument, always put the guard in the down position before pushing the instrument into the rack.*

The rackmount kit includes a bracket with a CD guard tab that mounts on the front-right side of the instrument. See Figure 12 on page 24. The guard tab is on the inside edge of the bracket, and prevents the drive from opening when the guard is in the down (guard) position. A guard status indicator on the front of the bracket displays red when the guard is in the up (unguarded) position.



CAUTION. *To avoid damaging the instrument, first check the guard status indicator before sliding the instrument in or out of the rack. If it is red, verify that the CD tray is closed, then push the guard down and move the instrument.*

There is no safeguard to prevent the instrument from being pushed into the rack if the guard is not in the down (guard) position.



CAUTION. *To prevent damage to the instrument, always put the guard in the down position before pushing the instrument into the rack.*

Do not eject a CD with the system software while the instrument is all the way in the rack. If the guard is not in the guard position, the CD tray will become trapped behind the vertical rack rails, and you will need to close the tray before you can pull out the instrument. Depending on the location of the adjacent instruments in the rack, you may have to access the CD tray from the back of the rack.

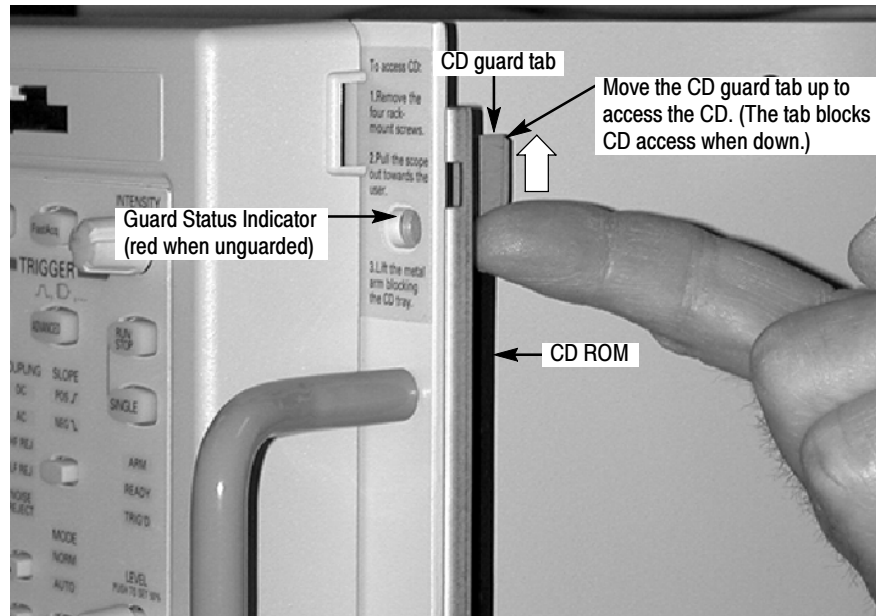

Figure 12: Guard detail

Accessing the CD Drive or Optional Internal Printer

If you need access to the CD drive or the internal printer, do the following:

1. If the instrument is pushed fully back in the rack, verify that the red indicator is not showing (the CD guard is in the guard position). If the indicator is red, verify that the CD tray is closed, then push the guard down.
2. Pull the instrument out far enough to reach the CD drive or printer.
3. If you need access to the CD drive, move the guard up so that the red indicator shows, and insert or eject the CD as your task requires.
4. When you are done using the CD drive, move the guard down and verify that the red indicator is not showing. See Figure 12.
5. Push the instrument all the way back into the rack.

■ End of document ■