

User Manual



MTXS01 ISDB-T Transport Stream Remultiplexing Software

071-1793-01

This document supports firmware version 4.1 and above.

www.tektronix.com

Copyright © Tektronix, Inc. All rights reserved. Licensed software products are owned by Tektronix or its suppliers and are protected by United States copyright laws and international treaty provisions.

Tektronix products are covered by U.S. and foreign patents, issued and pending. Information in this publication supercedes that in all previously published material. Specifications and price change privileges reserved.

TEKTRONIX and TEK are registered trademarks of Tektronix, Inc.

Contacting Tektronix

Tektronix, Inc.
14200 SW Karl Braun Drive
P.O. Box 500
Beaverton, OR 97077
USA

For product information, sales, service, and technical support:

- In North America, call 1-800-833-9200.
- Worldwide, visit www.tektronix.com to find contacts in your area.

Warranty 9(b)

Tektronix warrants that the media on which this software product is furnished and the encoding of the programs on the media will be free from defects in materials and workmanship for a period of three (3) months from the date of shipment. If any such medium or encoding proves defective during the warranty period, Tektronix will provide a replacement in exchange for the defective medium. Except as to the media on which this software product is furnished, this software product is provided "as is" without warranty of any kind, either express or implied. Tektronix does not warrant that the functions contained in this software product will meet Customer's requirements or that the operation of the programs will be uninterrupted or error-free.

In order to obtain service under this warranty, Customer must notify Tektronix of the defect before the expiration of the warranty period. If Tektronix is unable to provide a replacement that is free from defects in materials and workmanship within a reasonable time thereafter, Customer may terminate the license for this software product and return this software product and any associated materials for credit or refund.

THIS WARRANTY IS GIVEN BY TEKTRONIX WITH RESPECT TO THE PRODUCT IN LIEU OF ANY OTHER WARRANTIES, EXPRESS OR IMPLIED. TEKTRONIX AND ITS VENDORS DISCLAIM ANY IMPLIED WARRANTIES OF MERCHANTABILITY OR FITNESS FOR A PARTICULAR PURPOSE. TEKTRONIX' RESPONSIBILITY TO REPLACE DEFECTIVE MEDIA OR REFUND CUSTOMER'S PAYMENT IS THE SOLE AND EXCLUSIVE REMEDY PROVIDED TO THE CUSTOMER FOR BREACH OF THIS WARRANTY. TEKTRONIX AND ITS VENDORS WILL NOT BE LIABLE FOR ANY INDIRECT, SPECIAL, INCIDENTAL, OR CONSEQUENTIAL DAMAGES IRRESPECTIVE OF WHETHER TEKTRONIX OR THE VENDOR HAS ADVANCE NOTICE OF THE POSSIBILITY OF SUCH DAMAGES.

Table of Contents

Getting Started

Product Description	1-1
Standard Accessories	1-1
Installing the MTXS01 Software	1-2
Starting and Exiting the MTXS01 Software	1-5

Operating Basics

Elements of the Application Window	2-1
Using the MTXS01 Menus	2-7
Creating an ISDB-T Transport Stream File	2-15
Outputting an ISDB-T Transport Stream File	2-16

Appendices

Appendix A: Control Signal for the MTX100/A Option 02	A-1
Appendix B: Transmission Control Information	B-1
Multiplexing to Dummy Byte Part.	B-1
Multiplexing to IIP.	B-2

Index

List of Figures

Figure 1-1: Software protection key	1-2
Figure 2-1: MTXS01 application window	2-1
Figure 2-2: Parameters setting area	2-2
Figure 2-3: Configuration of the hierarchy display	2-5
Figure 2-4: Open dialog box	2-7
Figure 2-5: Load Parameter dialog box	2-8
Figure 2-6: Reset Parameter dialog box	2-9
Figure 2-7: Edit Data Rate dialog box	2-10
Figure 2-8: Edit Information dialog box	2-10
Figure 2-9: Employment Parameter dialog box	2-11
Figure 2-10: Open Setting for no PAT TS dialog box	2-14
Figure 2-11: Hierarchical view of the ISDB-T transport stream file ...	2-17
Figure 2-12: ISDB-T Information dialog box	2-18
Figure A-1: Timing relationship of the signals on the Universal In/Out connector	A-2

List of Tables

Table 2-1: Parameters for hierarchical transmission patterns	2-12
Table A-1: Pin assignment of the Universal In/Out connector	A-1
Table B-1: Multiplexed information to dummy bytes	B-1
Table B-2: Configuration of the IIP packet	B-2
Table B-3: Configuration of modulation_control_configuration_ information	B-3



Getting Started

Getting Started

This section provides the following information:

- Product description
- List of standard accessories
- MTXS01 software installation instructions
- MTXS01 software start and exit instructions

Product Description

The MTXS01 software provides the capability to create a transport stream defined in the ARIB STD-B31 “Transmission System for Digital Terrestrial Television Broadcasting” standard from an MPEG-2 transport stream. The transport stream that is remultiplexed by the MTXS01 software can be played from a Tektronix MTX100/A MPEG Recorder & Player or RTX100/A ISDB-T RF Signal Generator.

NOTE. You can play a transport stream file created by the current version of the MTXS01 software from the MTX100A/RTX100A, MTX100 with firmware version 2.0 or later, and RTX100 with firmware version 4.0 or later.

In the MTXS01 software, modulation parameter information is not inserted into SI tables of a created transport stream file.

Requirements

You can install the MTXS01 software on a Tektronix MTX100/A, RTX100/A, or a PC with the following minimum requirements:

- Windows XP/2000/NT operating system
- CD-ROM drive (for software installation)

Standard Accessories

The following accessories are shipped with the MTXS01 software:

- English User Manual (Option L0), Tektronix part number 071-1793-XX.
- Japanese User Manual (Option L5), Tektronix part number 070-A861-XX
- Software protection key, Tektronix part number 650-4922-00.

Installing the MTXS01 Software

Perform the following steps to install the MTXS01 software on your MTX100/A, RTX100/A, or PC:

Attaching the Software Protection Key

Perform the following steps to attach the software protection key to the rear-panel Printer port of the MTX100/A or RTX100/A, or to the parallel port of the PC before using the MTXS01 software.

1. If there is a cable attached to the Printer port of the MTX100/A or RTX100/A, or to the parallel port of the PC, disconnect the cable.
2. Attach the software protection key (see Figure 1-1) to the Printer port or parallel port and tighten the retention screws.

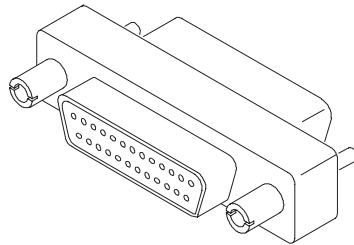

Figure 1-1: Software protection key

3. If you removed a cable in step 1, reconnect it directly to the software protection key.

NOTE. To run the MTXS01 software, the software protection key must be installed on the Printer port of the MTX100/A or RTX100/A, or on the parallel port of the PC. Do not remove or misplace the software key.

Uninstalling the Existing MTXS01 Software

If an earlier version of the MTXS01 software is installed, perform the following steps to uninstall the existing MTXS01 software:

1. For a MTX100/A or RTX100/A, select **File > Exit** in the Play or Record screen to exit the MTX100/A or RTX100/A application. The Windows desktop appears.
2. Select **Settings > Control Panel** from the **Start** menu. The **Control panel** window appears.
3. Double-click the **Add or Remove Programs** icon. The **Add or Remove Programs Properties** dialog box appears.
4. Select the **ISDB-T Remux** in the list, and then click the **Remove** button.

5. After you remove the software, restart Windows.

Installing the Software

Perform the following steps to install the MTXS01 software:

1. For a MTX100/A or RTX100/A, select **File > Exit** in the Play or Record screen to exit the MTX100/A or RTX100/A application. The Windows desktop appears.
2. Log on to Windows as Administrator.
3. Insert the *MTXS01 Version 4.1* CD-ROM into the CD-ROM (or DVD) drive.
4. Double-click the **My Computer** icon.
5. Double-click the **CD-ROM** (or **DVD**) drive icon.
6. Double-click the **Application** folder.



CAUTION. To prevent data loss, it is strongly recommended that you exit any open application on your PC before you run the *MTXS01 setup.exe* file.

7. Double-click **setup.exe** icon in the list. The MTXS01 installation program displays a series of setup windows as listed below. Click the **Next>** button to accept the default parameters, or change the parameters in the setup windows to suit your needs. Click the **Back** button in a setup window to return to the previous setup window.
 - a. Welcome window. Read the displayed information, and then click the **Next** button to proceed with the installation.
 - b. Choose Destination Location window. The default directory location for the application is displayed. If you want to install the MTXS01 software in a custom location, click the **Browse...** button, and then select or create a custom directory location.
 - c. Select Program Folder window. The default name for the program folder is displayed. If you want to change the name, type in a new name or select a name from the Existing Folders list. Click the **Next>** button to proceed.
 - d. Start Copying Files window. Review the displayed information, and then click the **Next>** button to start the installation.
 - e. Setup Complete window. If the installation is successful, you will see a message that setup has finished installing the MTXS01 software onto your PC. If you want to run the MTXS01 software immediately, select **Yes, Launch the program file**, and then click the **Finish** button. To exit the installation program without running the software, click the **Finish** button.

Installing the Parallel Driver

Perform the following steps to install the parallel driver:

1. Double-click the **Driver** folder in the *MTXS01 Version 4.1* CD-ROM.
2. Double-click the **SSD5411-32bit.EXE** icon.
3. Click **Next** in the resulting window. The **License Agreement** window appears.
4. Select **I accept the terms in the license agreement**, and then click **Next**. The **Destination Folder** window appears.
5. Click **Next**. The **Setup Type** window appears.
6. Select **Complete** and click **Next**. The **Ready to Install Program** window appears.
7. Click **Install** to proceed with installation.
8. When the **InstallShield Wizard Completed** window appears, click **Finish** to complete the installation.
9. Remove the *MTXS01 Version 4.1* CD-ROM from the CD-ROM (or DVD) drive, and then store the CD-ROM in a safe location.

Creating a Desktop Shortcut Icon

Perform the following steps to create an icon on the Windows desktop that you can use to run the MTXS01 software:

1. On your Windows desktop, move the mouse cursor to any unoccupied area, and then click the right mouse button to open the desktop menu.
2. From the desktop menu, select **New > Shortcut** to open the Create Shortcut dialog box.
3. Click the **Browse...** button in the Create Shortcut dialog box.
4. Use the Browse dialog box to locate the ISDB-T Remux directory.
 - a. If you installed the MTXS01 software using the default directory location and the default folder name in the installation procedure, select the following directory folders in order: **Program Files**, **Tektronix**, and **ISDB-T_Remux**.
 - b. If you installed the MTXS01 software to a custom location or gave the application folder a custom name, you will need to select your custom directory path.
 - c. You should now be at a location in the directory structure where the browse list box shows the **ISDB-T_Remux.exe** file.

5. Select the **ISDB-T_Remux.exe** file, and then click the **Open** button. The directory path to the ISDB-T Remux.exe file will now be displayed in the Command Line box of the Create Shortcut dialog box.
6. Click the **Next>** button in the Create Shortcut dialog box. The default name of the shortcut icon is now displayed in the dialog box. You can edit the icon name to suit your needs or accept the default name.
7. Click **Finish**. The ISDB-T_Remux.exe shortcut icon will appear on the Windows desktop.

Starting and Exiting the MTXS01 Software

When you complete the installation procedure, you can use either of the following methods to start the MTXS01 software:

- On the Windows desktop, double-click the **ISDB-T_Remux.exe** shortcut icon that you created during the installation procedure.
- Select **Tektronix > ISDB-T Remux** from the **Start - Programs** menu.

To exit (quit) the MTXS01 software, select **File > Exit** or click the close box on the title bar.



Operating Basics

Operating Basics

This section provides the following information:

- Elements of the application window
- Using the MTXS01 menus
- Creating an ISDB-T transport stream file
- Outputting an ISDB-T transport stream file

Elements of the Application Window

Figure 2-1 shows the display elements of the MTXS01 application window.

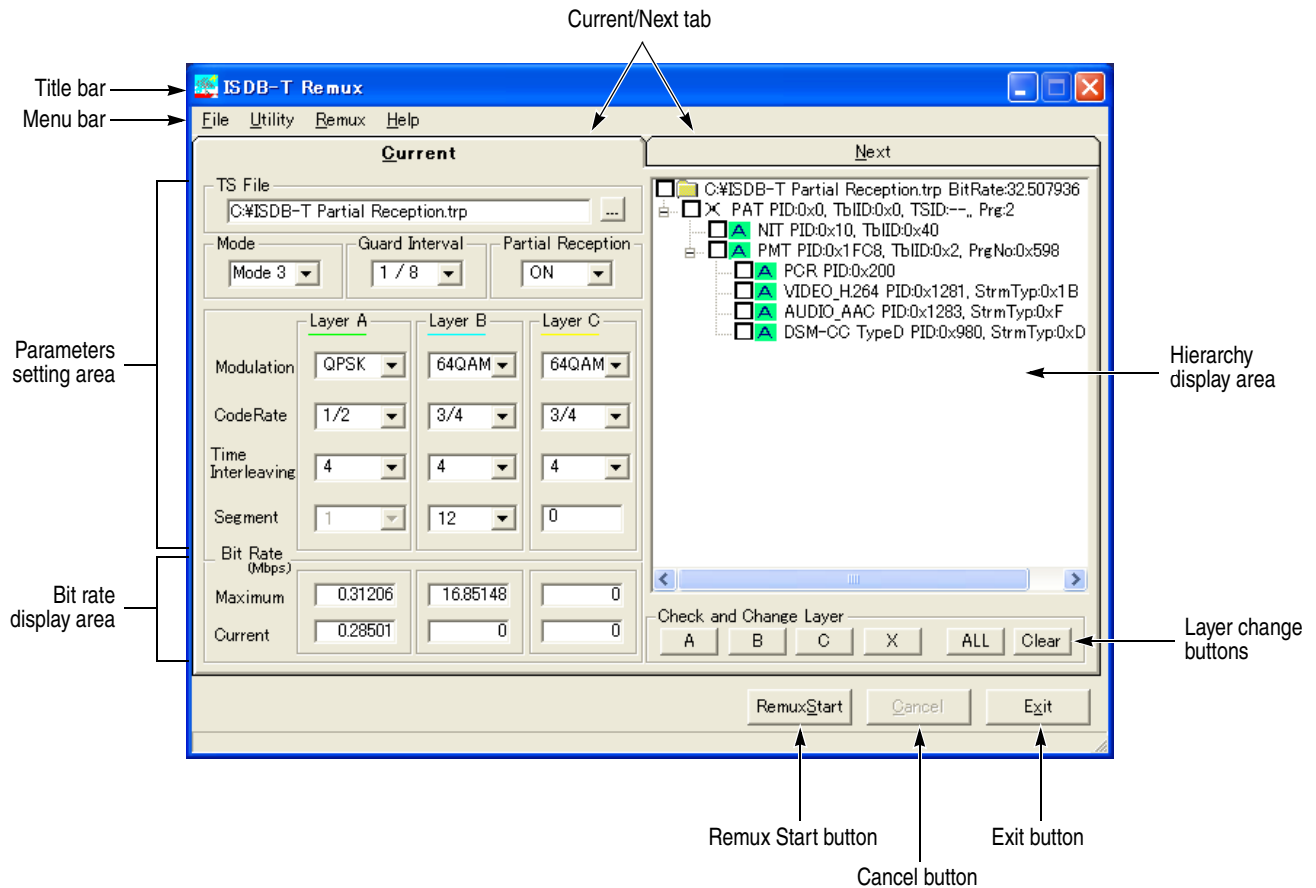

Figure 2-1: MTXS01 application window

Title Bar The title bar displays the name of the software. It also contains the standard window-sizing boxes for Windows.

Menu Bar The menu bar displays the names of the pull-down menus. Refer to *Using the MTXS01 Menus* on page 2-7 for detailed information about the functions available in the menus.

Current/Next Tab Switches the Current parameters setting pane from/to Next parameters setting pane. Use the Next parameters setting pane if you want to continuously output a transport stream file that has a different modulation scheme than the first one. You cannot set only parameters in the Next tab.

NOTE. Be sure to deselect the Regeneration PCR command in the Utility menu if you set parameters in both Current and Next tabs.

When playing a remultiplexed transport stream created using the Current and Next tabs from the MTX100/A or RTX100/A, disable the Update command in the Play menu.

Parameters Setting Area In the parameters setting area, there are fields to set transmission parameters for remultiplexing a transport stream (see Figure 2-2).

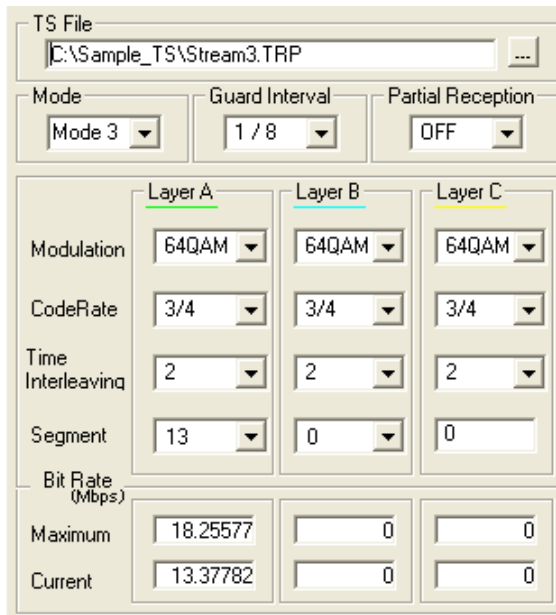

Figure 2-2: Parameters setting area

- **TS File:** Specifies a transport stream file to be remultiplexed. To specify a transport stream file, use the Open TS file command in the File menu or the “...” button next to the text box.
- **Mode:** Selects the transmission mode. You can select Mode 1, Mode 2, or Mode 3.
- **Guard Interval:** Selects the guard-interval ratio. You can select 1/32, 1/16, 1/8, or 1/4.
- **Partial Reception:** Specifies whether or not partial reception is available in the hierarchical layer A.
- **Modulation:** Selects the carrier modulation scheme for each hierarchical layer. You can select DQPSK, QPSK, 16QAM, or 64QAM.
- **Code Rate:** Selects the inner-code coding rate for each hierarchical layer. You can select 1/2, 2/3, 3/4, 5/6, or 7/8.
- **Time Interleaving:** Selects the time interleaving length for each hierarchical layer. Selectable values depend on the System Type setting in the Utility menu and the transmission mode setting.

System Type setting	Mode setting	Selectable values
Digital TV	Mode 1	0, 4, 8, 16
	Mode 2	0, 2, 4, 8
	Mode 3	0, 1, 2, 4
Digital Sound 3 Segment or Digital Sound 1 Segment	Mode 1	0, 4, 8, 16, 32
	Mode 2	0, 2, 4, 8, 16
	Mode 3	0, 1, 2, 4, 8

- **Segment:** Sets the number of OFDM segments for each hierarchical layer. The values are determined as follows:

Hierarchical layer A: You can set the value from 1 to 13. If you set the Partial Reception list box to ON, you cannot set values other than 1.

Hierarchical layer B: You can set the value less than or equal to 13–(setting value of the hierarchical layer A). At this time, the number of segments for the hierarchical layer C is set automatically; 13–(setting value of the hierarchical layer A)–(setting value of the hierarchical layer B).

Hierarchical layer C: The value depends on the settings of the hierarchical layers A and B.

Bit Rate Display Area

Displays the maximum and current bit rates of the selected transport stream. These values are calculated by 188 bytes/packet.

- **Maximum:** Displays the maximum bit rate calculated from the current parameter settings.
- **Current:** Displays the total information bit rate of the selected transport stream.

NOTE. If the Current value is larger than the Maximum value, the background of the Current field will turn red to indicate that you cannot perform any remultiplexing process under the current parameter settings.

If Partial Reception is set to ON, you may not perform any remultiplexing process even if the Current value is smaller than the Maximum value.

If the time length of an elementary stream data is shorter than that of a transport stream file, the Current bit rate for the layer that has the elementary stream data is not displayed correctly (see the illustration below). In this case, if you remultiplex the file, relative time values of PCRs and PTS/DTSS in a created ISDB-T transport stream file may become incorrect.

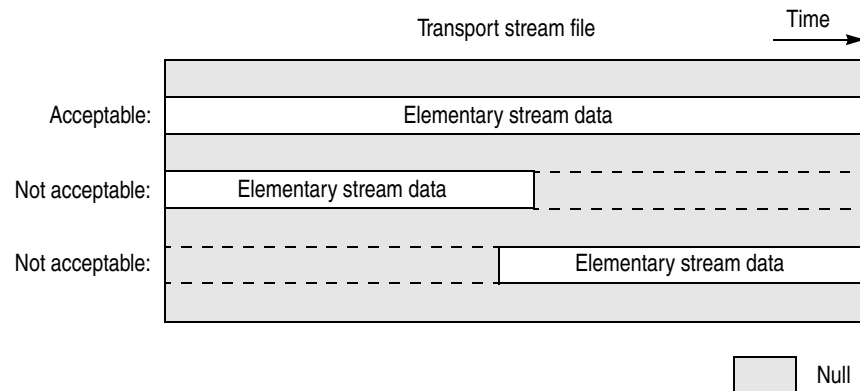

Hierarchy Display Area

When you select a transport stream to be remultiplexed, a hierarchy display appears in the right side of the application window. Figure 2-3 shows the configuration of the hierarchy display.

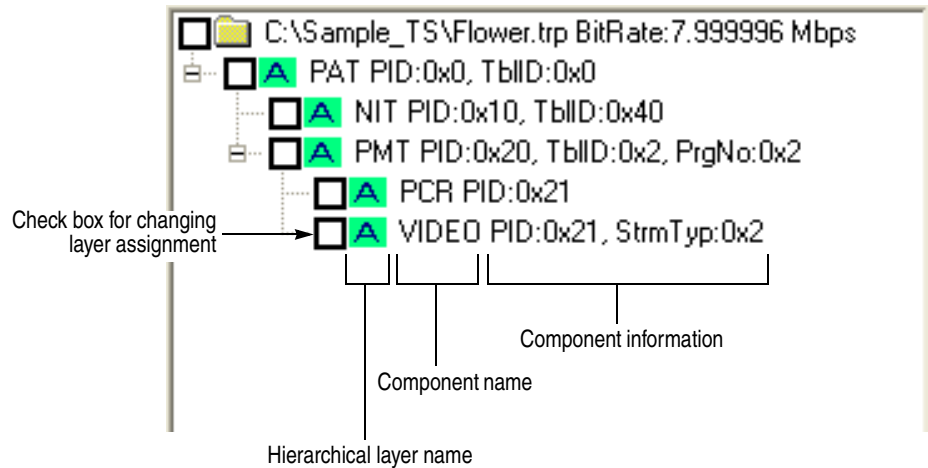

Figure 2-3: Configuration of the hierarchy display

Check Box for Changing Layer Assignment. Sets whether to change the hierarchical layer for the transport stream component. When you select the check box, you can change the hierarchical layer using buttons in the Check and Change Layer field. Refer to *Layer Change Buttons* on page 2-6.

Hierarchical Layer Name. Shows the hierarchical layer name (A, B, or C) to which the transport stream component is assigned. For PID and IIP (ISDB-T Information Packet) that do not exist the packet, an x-indication is displayed instead of the hierarchical layer name.

Component Name. Shows the name of the transport stream component.

Component Information. Shows information about the transport stream component such as a packet ID or table ID.

The component information used in the MTXS01 software is common to the information used in the MTX100/A and RTX100/A. For detailed information about each transport stream component, refer to the User manual supplied with the instrument.

Layer Change Buttons

By default, all of the transport stream components are assigned to the hierarchical layer A. You can change the layer assignment for the components using the buttons in the Check and Change Layer field.

- **A/B/C buttons:** Changes the hierarchical layer of the transport stream component that have a check mark to the hierarchical layer corresponding to the button.
- **× button:** Replaces the transport stream component that have a check mark with a null packet.
- **ALL button:** Selects all the check boxes of the transport stream components.
- **Clear button:** Clears all the check boxes of the transport stream components.

Perform the following steps to change the hierarchical layer assignment for a transport stream component:

1. Click the check box(es) of the component(s) for which you want to change the hierarchical layer. If necessary, use the **ALL** or **Clear** button. You can select check boxes by dragging a mouse on components with the left-mouse button pressed. (If you drag a mouse on components with the right-mouse button pressed, you can clear check boxes).
2. Click the **A**, **B**, **C**, or **×** button to change the assignment.

You can also change the hierarchical layer assignment by clicking a layer name on the hierarchy display. In this case, the layer name changes to A-B-C-× in turn.

There are some restrictions on the hierarchical layer assignment for the transport stream components:

- You cannot assign the hierarchical layer that does not set the number of segments.
- If a PCR is included within a packet that has the same PID as the other component, you cannot assign different hierarchical layers to the components.
- If there are two or more components that have the same PID, when you change a hierarchy layer of a component, the other components are also changed to the same hierarchical layer.

Remux Start Button Starts the remultiplexing process.

Cancel Button Cancels the file loading or remultiplexing process.

Exit Button Exits the MTXS01 software.

Using the MTXS01 Menus

The menu bar displays the names of the four pull-down menus: File, Utility, Remux, and Help. This section describes the function of each selection in these menus.

File Menu The File menu contains commands for managing file operation.

The commands are as follows:

Open TS File. Selects a transport stream file to be remultiplexed.

When you select **File > Open TS File**, the Open dialog box appears as shown in Figure 2-4.

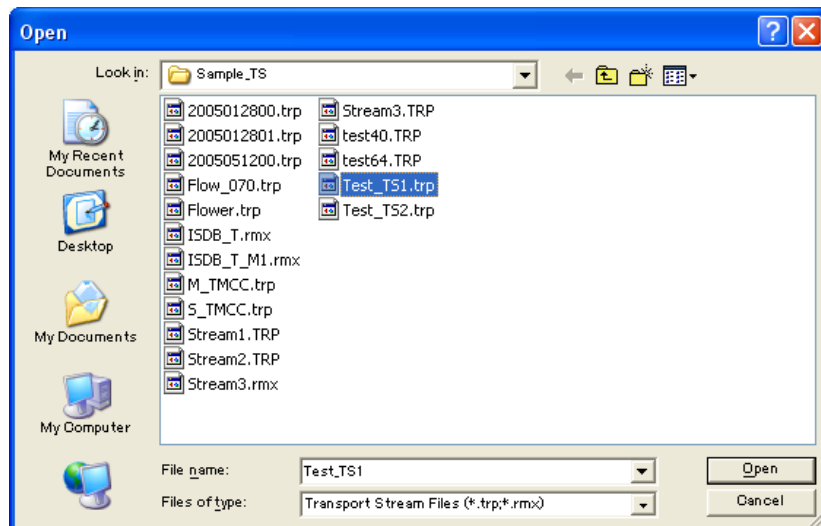

Figure 2-4: Open dialog box

Select the transport stream file you want to remultiplex in the file list and click the Open button to open the file.

NOTE. For the selected transport stream to be recognized as a transport stream file, sync bytes must be identified in five consecutive transport stream packets.

If a sync byte is identified in the middle of a transport stream file, the data before the sync byte are invalid. In addition, the end of data that is less than 188 bytes is invalid.

Close TS File. Closes the currently selected file.

Load Parameter. Loads a saved parameter file (.prm) to use as the current settings.

When you select **File > Load Parameter**, and then you select a parameter file in the Open dialog box, a dialog box appears as shown in Figure 2-5.

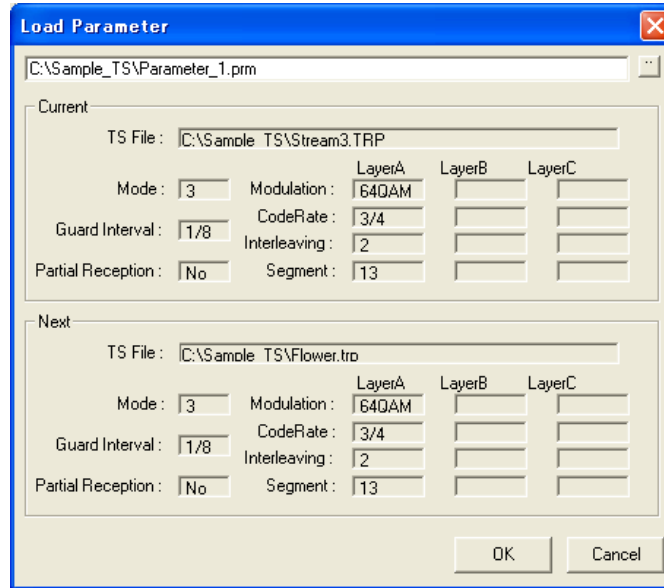

Figure 2-5: Load Parameter dialog box

If you click the “...” button at the right side of the text box, the Open dialog box appears and you can select another parameter file.

NOTE. A parameter file (.prm) created by version 4.1 of the MTXS01 software cannot be opened by earlier versions of the software.

Save Parameter. Saves the names of the transport stream files and their parameters in the Current and Next tabs to a specified parameter file (.prm).

Reset Parameter. Resets the current parameter settings to the default values.

When you select **File > Reset Parameter**, a dialog box appears as shown in Figure 2-6.

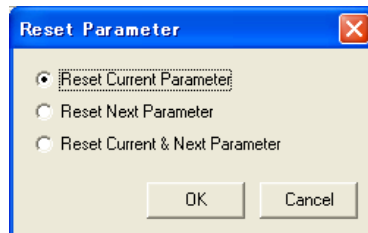

Figure 2-6: Reset Parameter dialog box

- **Reset Current Parameter:** Resets the parameters in the Current tab to the default settings.
- **Reset Next Parameter:** Resets the parameters in the Next tab to the default settings.
- **Reset Current & Next Parameter:** Resets the parameters in the Current and Next tabs to the default settings.

Minimize. Minimizes the MTXS01 application window.

Exit. Exits the MTXS01 software.

Utility Menu

The Utility menu contains commands that select the digital broadcast type and set the parameters needed for remultiplexing transmission control information.

The commands are as follows:

System Type. Specifies the terrestrial digital broadcasting type.

Edit Data Rate. Changes the data rate of the currently loaded transport stream file. The data rate of the loaded transport stream file may be different from the actual data rate because it is calculated based on PCRs in the file. In this case, you can change the data rate using this command.

When you select **Utility > Edit Data Rate**, a dialog box appears as shown in Figure 2-7. If you change the data rate, the bit rate in the parameters setting area is also changed.

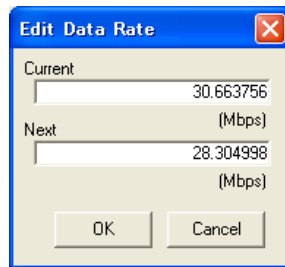

Figure 2-7: Edit Data Rate dialog box

- **Current:** Changes the data rate of the transport stream file in the Current tab.
- **Next:** Changes the data rate of the transport stream file in the Next tab.

Edit Information. Sets parameters needed for remultiplexing transmitting control information.

When you select **Utility > Edit Information**, a dialog box appears as shown in Figure 2-8. The settings become available at the next remultiplexing process.

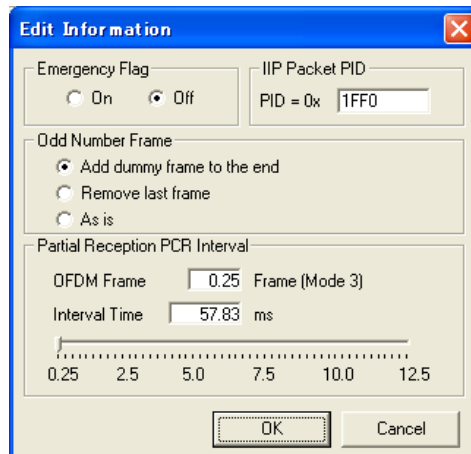

Figure 2-8: Edit Information dialog box

- **Emergency Flag:** Enables the start flag for emergency-alarm broadcasting.
- **IIP Packet PID:** Specifies the PID of the ISDB-T information packet. The default value is 0x1FF0.
- **Odd Number Frame:** Selects how to process the last frame if the number of multiplex frames are odd numbers. You can select Add dummy frame to the end, Remove last frame, or As is.
- **Partial Reception PCR Interval:** Sets the interval between PCR packets when partial reception is specified in the hierarchical layer A.

Move the slider with the left mouse button pressed to set the interval time. The value in the OFDM Frame box indicates the interval between frames that include PCRs.

Employment Parameter. Sets the parameters for hierarchical transmission to the hierarchical transmission patterns defined in ARIB TR-B14.

When you select **Utility > Employment Parameter**, a dialog box appears as shown in Figure 2-9.

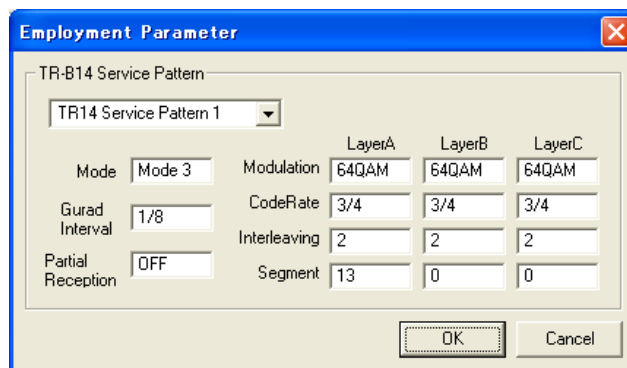

Figure 2-9: Employment Parameter dialog box

- **TR-B14 Service Pattern:** Selects one of the hierarchical transmission patterns.

Table 2-1 shows the parameters for hierarchical transmission patterns set by TR14 Service Pattern 1 to TR14 Service Pattern 6.

Table 2-1: Parameters for hierarchical transmission patterns

TR14 Service Pattern 1			
Mode	3		
Guard Interval	1/8		
Partial Reception	OFF		
	Layer A	Layer B	Layer C
Modulation	64QAM	64QAM	64QAM
Code Rate	3/4	3/4	3/4
Interleaving	2	2	2
Segment	13	0	0
TR14 Service Pattern 2			
Mode	3		
Guard Interval	1/8		
Partial Reception	OFF		
	Layer A	Layer B	Layer C
Modulation	16QAM	64QAM	64QAM
Code Rate	1/2	3/4	3/4
Interleaving	4	4	4
Segment	13	0	0
TR14 Service Pattern 3			
Mode	3		
Guard Interval	1/8		
Partial Reception	ON		
	Layer A	Layer B	Layer C
Modulation	QPSK	64QAM	64QAM
Code Rate	1/2	3/4	3/4
Interleaving	4	4	4
Segment	1	12	0
TR14 Service Pattern 4			
Mode	3		
Guard Interval	1/8		
Partial Reception	OFF		
	Layer A	Layer B	Layer C
Modulation	16QAM	64QAM	64QAM
Code Rate	1/2	3/4	3/4
Interleaving	4	4	4
Segment	3	10	0

Table 2-1: Parameters for hierarchical transmission patterns (cont.)

TR14 Service Pattern 5			
Mode	3		
Guard Interval	1/8		
Partial Reception	ON		
	Layer A	Layer B	Layer C
Modulation	QPSK	16QAM	64QAM
Code Rate	1/2	1/2	3/4
Interleaving	4	4	4
Segment	1	12	0
TR14 Service Pattern 6			
Mode	2		
Guard Interval	1/4		
Partial Reception	OFF		
	Layer A	Layer B	Layer C
Modulation	QPSK	16QAM	64QAM
Code Rate	1/2	1/2	3/4
Interleaving	2	2	2
Segment	1	3	9

Regenerated PCR. Selects whether to recalculate PCR values when remultiplexing a transport stream.

NOTE. Be sure to clear the command if you have set the parameters in both *Current* and *Next* tabs. In addition, if you play a remultiplexed transport stream created using the *Current* and *Next* tabs from the *MTX100/A* or the *RTX100/A*, set the *Update* command in the *Play* menu of the instrument to *Off*.

Duplicate Packet. Specifies whether to duplicate PAT, NIT, and CAT in null packets in the hierarchical layer A when the following conditions are met:

1. Partial reception is specified in hierarchical layer A.
2. Either the hierarchical layer B or C is the most robust layer.
3. PAT, NIT, or CAT is included in hierarchical layer B or C.

Open Setting for no PAT TS. Enables loading a transport stream that does not contain any PATs (Program Association Tables) by specifying PID values for PMTs (Program Map Tables).

When you select **Utility > Open Setting for no PAT TS**, a dialog box appears as shown in Figure 2-10.

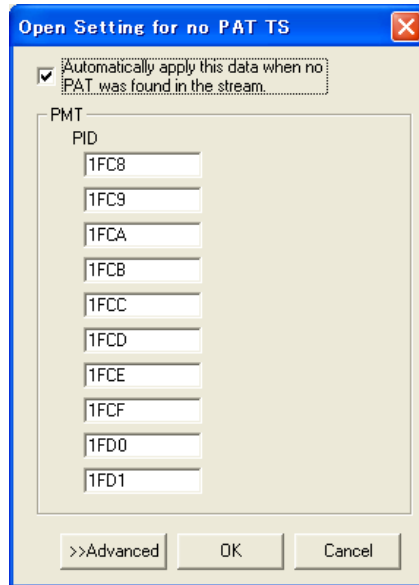

Figure 2-10: Open Setting for no PAT TS dialog box

- **Automatically apply this data when no PAT was found in the stream:**
Sets whether to load the transport stream by using the PMT PID values that are specified in the dialog box when loading a transport stream that does not contain any PATs (if a transport stream contains any PAT, it is loaded using the PAT). If you clear the check box, a transport stream that does not contain a PAT cannot be loaded. By default, the check box is selected.
- **PMT PID:** Specifies each PID value for PMTs in a transport stream to be loaded. By default, the upper eight PID values are set to those that are allocated by the ARIB TR-B14 standard. If you do not specify a PID value for a PMT, it is not recognized as a PMT.

If you click the **Advanced** button, text boxes to set more PID values and program numbers of PMTs are displayed. Use these text boxes to load PMTs with the same PID value but a different program number. In addition, a text box to set a PID value for an NIT (Network Information Table) is displayed. By default, it is set to 0x0010.

Remux Menu The Remux menu contains commands that start and cancel the remultiplexing process.

The commands are as follows:

Start. Start the remultiplexing process.

Cancel. Cancels the remultiplexing process.

Help Menu The Help menu contains command that display the version information about the MTXS01 software.

About. Displays information including the software version number and copyright information.

Creating an ISDB-T Transport Stream File

This section describes basic procedures for creating an ISDB-T transport stream file from an MPEG-2 transport stream file.

1. Select **File > Open TS File** to open the **Open** dialog box.
2. Select the transport stream file you want to remultiplex, and then click the **Open** button.

After the file is loaded, the “Analysis Complete” message appears.
3. Click the **OK** button in the dialog box.
4. Set the transmission parameter for remultiplexing the transport stream in the parameters setting area.
 - a. Set the transmission mode in the **Mode** list box.
 - b. Set the guard interval ration in the **Guard Interval** list box.
 - c. Set the number of segments for hierarchical layers A and B in the **Segment** list boxes.
 - d. Set whether or not partial reception is available in the hierarchical layer A in the **Partial Reception** list box.
 - e. Set the carrier modulation scheme for each hierarchical layer in the **Modulation** list boxes.
 - f. Set the inner-code coding rate for each hierarchical layer in the **Code Rate** list boxes.

- g. Set the time interleaving length for each hierarchical layer in the **Time Interleaving** list boxes.

If you use the **Employment Parameter** command in the **Utility** menu, you can set the parameters to the hierarchical transmission pattern defined in ARIB TR-B14.

5. In the hierarchy display area, change the hierarchical layer assignment (A, B, C, or, ×) for transport stream components (refer to *Layer Change Buttons* on page 2-6).
6. If necessary, click the **Next** tab and repeat steps 1 through 5 to set the parameters.
7. Select **Utility > Edit Data Rate** to open the **Edit Data Rate** dialog box.
8. In the dialog box, change the data rate of the selected transport stream.
9. Select **Utility > Edit Information** to open the **Edit Information** dialog box.
10. In the dialog box, set the parameters needed for remultiplexing transmitting control information.
11. When you set the all the parameters, click the **Remux Start** button or select **Remux > Start**. The **Save As** dialog box appears.
12. Enter a file name in the **File name** text box (if you do not use the default file name).
13. Click the **Save** button.

This creates a transport stream file defined in the ARIB STD-B31 standard.

Outputting an ISDB-T Transport Stream File

This section describes how to output an ISDB-T transport stream file from the MTX100/A or RTX100/A.

NOTE. *The MTX100/A Option 02 has different pull-down menu configuration and pin assignment of the Universal In/Out connector when outputting an ISDB-T transport stream file.*

1. Press the front-panel **PLAY** button to display the Play screen (if not displayed).
2. Select **File > Open** to open the **Select File** dialog box.
3. In the dialog box, select the ISDB-T transport stream file (.rmx) you want to output.

The hierarchical view of the selected file is displayed on the screen as shown in Figure 2-11.

NOTE. The ISDB-T transport stream is different from the typical transport stream, so the icon is not represented as a train.

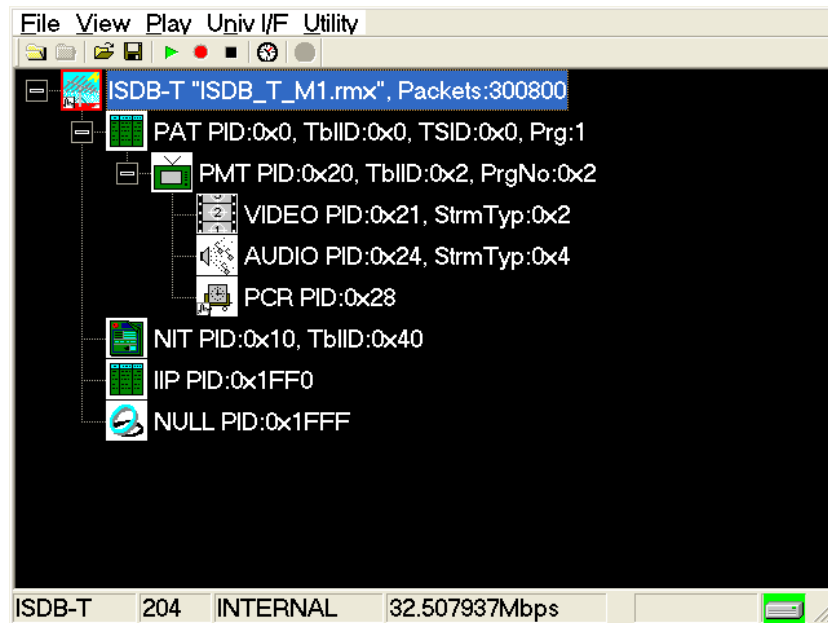

Figure 2-11: Hierarchical view of the ISDB-T transport stream file

4. Select the ISDB-T transport stream icon and press the front-panel **SELECT** button (or click the icon with the right mouse button) to open the **ISDB-T Information** dialog box shown in Figure 2-12.

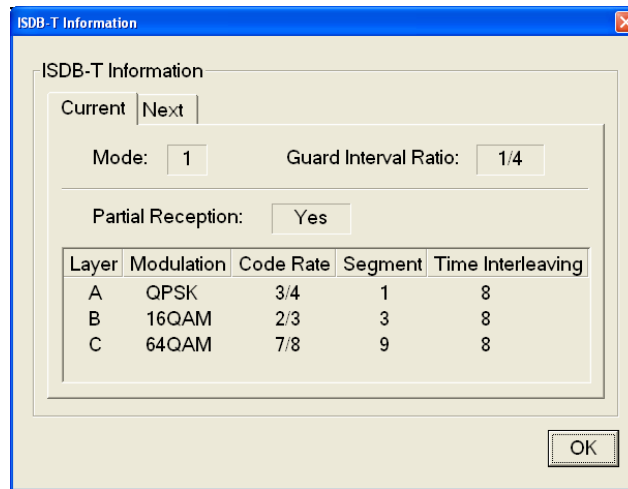

Figure 2-12: ISDB-T Information dialog box

Use this dialog box to check the transmission parameters of the ISDB-T transport stream.

For the MTX100/A (other than Option 02) or RTX100/A:

5. Use an interface cable to connect the **SPI In/Out** connector (or the output connector on the installed option card) on the MTX100/A or the RTX100/A and an ISDB-T modulator.
6. Press the **PLAY** button on the MTX100/A or RTX100/A to output the transport stream.

For the MTX100/A Option 02:

7. Use an interface cable to connect the **SPI In/Out** connector on the MTX100/A Option 02 and the TSP input on the ISDB-T modulator.
8. Use an interface cable to connect the **Universal In/Out** connector on the MTX100/A Option 02 and the PI input on the ISDB-T modulator.
9. Select **Univ I/F > PI Clock**. This menu item is available only when an ISDB-T transport stream file is loaded.
10. In the displayed submenu, select the scale factor of the Packet Information clock to the TS clock (4 MHz).

11. In the **Univ I/F** menu on the MTX100/A Option 02, make the following settings:

Level LVDS
Format Parallel
Clock Rise

12. Press the **PLAY** button on the MTX100/A Option 02 to output the transport stream.

At this time, the transport stream data is output from the SPI In/Out connector and control signals for the hierarchical multiplexing parameters are output from the Universal In/Out connector.

Refer to *Appendix A: Control Signals for the MTX100/A Option 02* for information about the pin assignments of the Universal In/Out connector and timing relationship of the output signals on the connector.



Appendices

Appendix A: Control Signal for the MTX100/A Option 02

For the MTX100/A Option 02, the control signals for the hierarchical multiplexing parameters are output from the Universal In/Out connector when outputting an ISDB-T transport stream.

This appendix describes the pin assignments of the Universal In/Out connector when the control signals are output and shows the timing relationship of these signals.

Table A-1 lists the pin assignment of the Universal In/Out connector.

Table A-1: Pin assignment of the Universal In/Out connector

Characteristics	Description			
Universal In/Out connector	D-sub, 25 pin			
Connect type	D-sub, 25 pin			
Pin assignment	1	Clock ¹	14	$\overline{\text{Clock}}$
	2	GND	15	$\overline{\text{GND}}$
	3	CD3	16	$\overline{\text{CD3}}$
	4	CD2	17	$\overline{\text{CD2}}$
	5	CD1	18	$\overline{\text{CD1}}$
	6	CD0	19	$\overline{\text{CD0}}$
	7	HFLAG3	20	$\overline{\text{HFLAG3}}$
	8	HFLAG2	21	$\overline{\text{HFLAG2}}$
	9	HFLAG1	22	$\overline{\text{HFLAG1}}$
	10	HFLAG0	23	$\overline{\text{HFLAG0}}$
	11	NC	24	$\overline{\text{NC}}$
	12	Frame	25	$\overline{\text{Frame}}$
	13	GND		

¹ The clock frequency can be selected from 4 MHz, 8 MHz, 16 MHz, or 32 MHz using the PI Clock command in the Univ I/F menu.

Figure A-1 shows the timing relationship of the signals on the Universal In/Out connector.

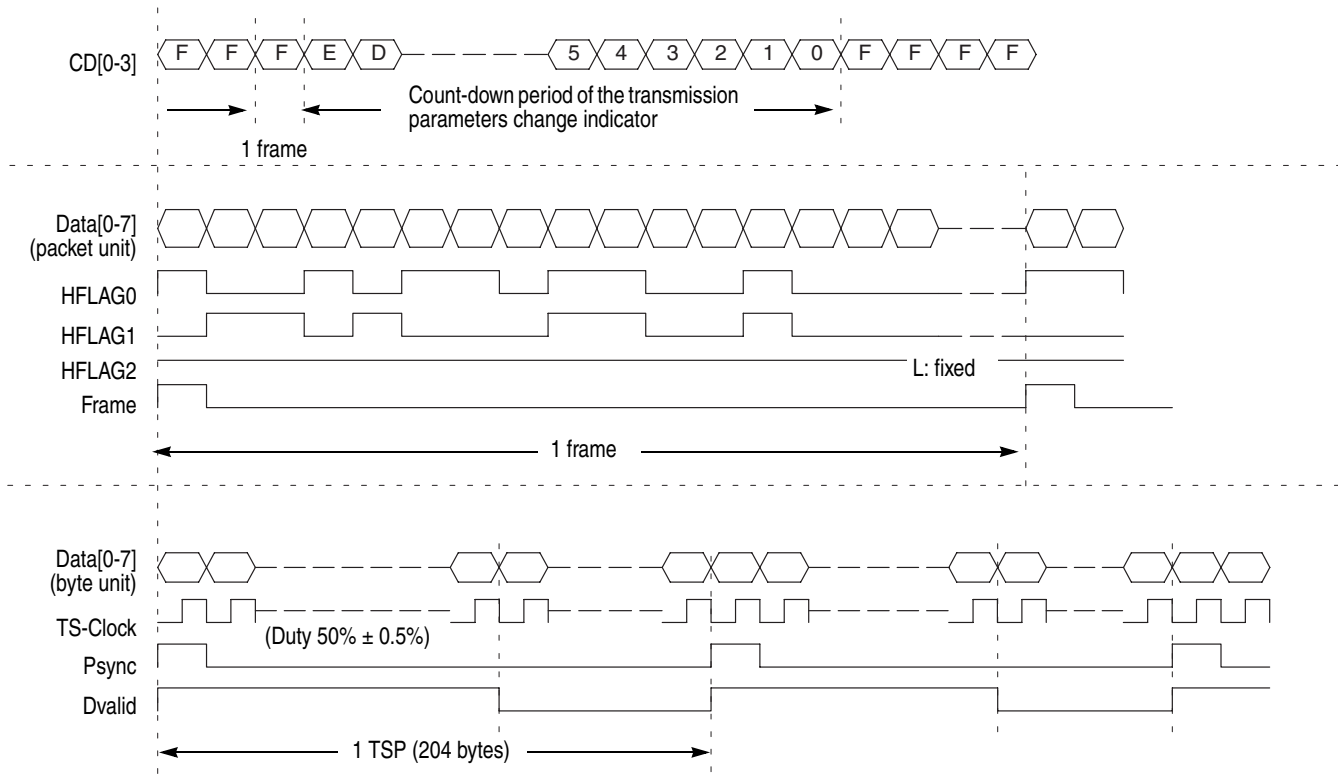

Figure A-1: Timing relationship of the signals on the Universal In/Out connector

Appendix B: Transmission Control Information

This appendix describes transmission control information multiplexed to a transport stream according as the ARIB STD-B31 5.5 standard.

Multiplexing to Dummy Byte Part

Table B-1 lists transmission control information multiplexed to dummy byte part of each transport steam packet (189 byte to 196 byte). Some of the information uses values set in the Edit Information dialog box in the Utility menu.

Table B-1: Multiplexed information to dummy bytes

Byte	Bit	Syntax	Description			
0(189)	7	TMCC_identifier	= 1	Terrestrial digital TV	= 1	Terrestrial digital audio
	6		= 0		= 1	
	5	reserved	"1"			
	4	buffer_reset_control_flag	"0"			
	3	switch-on_control_for_emergency_broadcasting	Set in the Edit Information dialog box.			
	2	initialization_timing_head_packet_flag	Start packet after changing a transmission parameter: "1" Normally: "0"			
	1	frame_head_packet_flag	The multiplex frame head packet: "1" Normally: "0"			
	0	frame_indicator	During even frame of the OFDM frame: "0" During odd frame of the OFDM frame: "1"			
1(190)	7-4	layer_indicator	"0000": dummy packet "0001": packet transmitted by hierarchical layer A "0010": packet transmitted by hierarchical layer B "0011": packet transmitted by hierarchical layer C "1000": ISDB-T information packet (IIP)			
	3-0	count_down_index	"1111": Normally "1110": 15 frames before switching "1101": 14 frames before switching : "0001": 2 frames before switching "0000": 1 frame before switching			
2(191)	7	AC_data_invalid_flag	"1"			
	6-5	AC_data_effective_bytes	All "1"			
	4-0	TSP_counter	A counter in which the head packet of the multiplex frame is 0 and increments one by one in order of packet.			
3(192)	7-0					

Table B-1: Multiplexed information to dummy bytes (cont.)

Byte	Bit	Syntax	Description
4(193)	7-0	AC_data	All "1"
5(194)	7-0	AC_data	All "1"
6(195)	7-0	AC_data	All "1"
7(196)	7-0	AC_data	All "1"

Multiplexing to IIP

Information except for Table B-1 is added to invalid hierarchy IIP (ISDB-T _Information_Packet), and the packet is replaced with one dummy packet in a multiplex frame. Some of the information uses values set in the Edit Information dialog box in the Utility menu. Table B-2 shows the configuration of the IIP packet.

Table B-2: Configuration of the IIP packet

Syntax	Description	Number of bits
sync_byte	synchronization byte: 0x47	8
transport_error_indicator	Always "0"	1
payload_unit_start_indicator	Always "1"	1
transport_priority	Always "0"	1
PID	The value is set in the Edit Information dialog box. Default value: 0x1FF0	13
transport_scrambling_control	Always "00"	2
adaptation_field_control	Always "01"	2
continuity_counter	The value is increased with each transport stream packet. It wraps around to 0 after its maximum value (0x1111).	4
IIP_packet_pointer	The number of packets from the multiplex position to the next multiplex frame head in the multiplex frame of the IIP.	16
modulation_control_configuration_information	See Table B-3.	160
IIP_branch_number	Always "0x00"	8
last_IIP_branch_number	Always "0x00"	8
network_synchronization_information_length	Always "0x00" (no SFN information)	8
stuffing_byte (0xFF)	159 (188-29) bytes 0xFF	8X159

Table B-3 shows the configuration of modulated_control_configuration_information.

Table B-3: Configuration of modulation_control_configuration_information

Syntax	Description	Number of bits
TMCC_synchronization_word	Even frame: "0" Odd frame: "1"	1
AC_data_effective_position	"1"	1
reserved	All "1"	2
initialization_timing_indicator	Switching timing of mode and guard interval ratio	4
current_mode	Current Mode value 00: reserved, 01: Mode 1, 10: Mode 2, 11: Mode 3	2
current_guard_interval	Current guard interval ratio 00: 1/32, 01: 1/16, 10: 1/8, 11: 1/4	2
next_mode	Next mode value	2
next_guard_interval	Next guard interval ratio	2
system_indicator	00: Terrestrial digital TV, 01: Terrestrial digital audio	2
count_down_index	Transmission parameter switching index	4
switch-on_control_flag_used_for_alert_broadcasting	The value is set in the Edit Information dialog box.	1
current_configuration_information	The following current information:	(40)
partial_reception_flag	Digital TV = partial reception flag 0: without partial reception, 1: with partial reception Digital sound = system identification flag 0: 1 segment system, 1: 3 segment system	1
transmission_parameter_for_layer_A	The following transmission-parameter information for hierarchical layer A:	(13)
modulation_scheme	Carrier modulation scheme 000: DQPSK, 001: QPSK, 010: 16 QAM, 011: 64 QAM, 111: unused hierarchical layer	3
coding_rate_of_inner_code	Convolution coding ratio 000: 1/2, 001: 2/3, 010: 3/4, 011: 5/6, 100: 7/8, 111: unused hierarchical layer	3
length_of_time_interleaving	Time interleaving length 000: 0 (Mode 1), 0 (Mode 2), 0 (Mode 3) 001: 4 (Mode 1), 2 (Mode 2), 1 (Mode 3) 010: 8 (Mode 1), 4 (Mode 2), 2 (Mode 3) 011: 16 (Mode 1), 8 (Mode 2), 4 (Mode 3) 100: 32 (Mode 1), 16 (Mode 2), 8 (Mode 3) 101-110: reserved 111: unused layer	3
number_of_segments	Number of segments 0001-1101: 1 to 13, 1111: unused hierarchical layer	4
transmission_parameter_for_layer_B	Transmission parameter information for hierarchical layer B (same as layer A)	(13)

Table B-3: Configuration of modulation_control_configuration_information (cont.)

Syntax	Description	Number of bits
transmission_parameter_for_layer_C	Transmission parameter information for hierarchical layer C (same as layer A)	(13)
next_configuration_information	Next information (same as the current information)	(40)
phase_correction_of_CP_in_connected_transmission	All "1"	3
TMCC_reserved_future_use	All "1"	12
reserved_future_use	All "1"	10
CRC_32	CRC value from TMCC_synchronization_word to reserved_future_use	32



Index

Index

A

A/B/C/X buttons, 2-6
ALL button, 2-6
Application window, 2-1
ARIB TR-B14, 2-11

C

Cancel button, 2-6
Clear button, 2-6
Close TS File command, 2-8
Code rate, 2-3
Current tab, 2-2

D

Duplicate Packet command, 2-13

E

Edit Data Rate command, 2-10
Edit Data Rate dialog box, 2-10
Edit Information command, 2-10
Edit Information dialog box, 2-10
Employment Parameter command, 2-11
Employment Parameter dialog box, 2-11
Exit button, 2-7
Exit command, 2-9
Exit, MTXS01 software, 1-5

F

File menu, 2-7

G

Guard interval, 2-3

H

Help menu, 2-15
Hierarchical transmission patterns, 2-12

I

IIP, B-2
Install, MTXS01 software, 1-3
Install, parallel driver, 1-4

L

Load Parameter command, 2-8
Load Parameter dialog box, 2-8

M

Menu bar, 2-2
Minimize command, 2-9

N

Next tab, 2-2

O

Open Setting for no PAT TS command, 2-14
Open Setting for no PAT TS dialog box, 2-14
Open TS File command, 2-7

P

Partial reception, 2-3
Product description, 1-1

R

Regenerate PCR command, 2-13
Remux menu, 2-15
Remux Start button, 2-6
Requirements, PC, 1-1
Reset Parameter command, 2-9
Reset Parameter dialog box, 2-9

S

Save Parameter command, 2-8
Software installation, 1-3
Software protection key, 1-2

Standard accessories, 1-1
Start, MTXS01 software, 1-5
System Type command, 2-9

T

Time interleaving, 2-3
Title bar, 2-2

U

Utility menu, 2-9