

TCP0030
120 MHz, 30 A AC/DC Current Probe
Instruction Manual

www.tektronix.com
071-1812-00

Tektronix

Copyright © Tektronix. All rights reserved. Licensed software products are owned by Tektronix or its subsidiaries or suppliers, and are protected by national copyright laws and international treaty provisions.

Tektronix products are covered by U.S. and foreign patents, issued and pending. Information in this publication supersedes that in all previously published material. Specifications and price change privileges reserved.

TEKTRONIX and TEK are registered trademarks of Tektronix, Inc.

Contacting Tektronix

Tektronix, Inc.
14200 SW Karl Braun Drive
P.O. Box 500
Beaverton, OR 97077
USA

For product information, sales, service, and technical support:

- In North America, call 1-800-833-9200.
- Worldwide, visit www.tektronix.com to find contacts in your area.

Warranty 2

Tektronix warrants that this product will be free from defects in materials and workmanship for a period of one (1) year from the date of shipment. If any such product proves defective during this warranty period, Tektronix, at its option, either will repair the defective product without charge for parts and labor, or will provide a replacement in exchange for the defective product. Parts, modules and replacement products used by Tektronix for warranty work may be new or reconditioned to like new performance. All replaced parts, modules and products become the property of Tektronix.

In order to obtain service under this warranty, Customer must notify Tektronix of the defect before the expiration of the warranty period and make suitable arrangements for the performance of service. Customer shall be responsible for packaging and shipping the defective product to the service center designated by Tektronix, with shipping charges prepaid. Tektronix shall pay for the return of the product to Customer if the shipment is to a location within the country in which the Tektronix service center is located. Customer shall be responsible for paying all shipping charges, duties, taxes, and any other charges for products returned to any other locations.

This warranty shall not apply to any defect, failure or damage caused by improper use or improper or inadequate maintenance and care. Tektronix shall not be obligated to furnish service under this warranty a) to repair damage resulting from attempts by personnel other than Tektronix representatives to install, repair or service the product; b) to repair damage resulting from improper use or connection to incompatible equipment; c) to repair any damage or malfunction caused by the use of non-Tektronix supplies; or d) to service a product that has been modified or integrated with other products when the effect of such modification or integration increases the time or difficulty of servicing the product.

THIS WARRANTY IS GIVEN BY TEKTRONIX WITH RESPECT TO THE PRODUCT IN LIEU OF ANY OTHER WARRANTIES, EXPRESS OR IMPLIED. TEKTRONIX AND ITS VENDORS DISCLAIM ANY IMPLIED WARRANTIES OF MERCHANTABILITY OR FITNESS FOR A PARTICULAR PURPOSE. TEKTRONIX' RESPONSIBILITY TO REPAIR OR REPLACE DEFECTIVE PRODUCTS IS THE SOLE AND EXCLUSIVE REMEDY PROVIDED TO THE CUSTOMER FOR BREACH OF THIS WARRANTY. TEKTRONIX AND ITS VENDORS WILL NOT BE LIABLE FOR ANY INDIRECT, SPECIAL, INCIDENTAL, OR CONSEQUENTIAL DAMAGES IRRESPECTIVE OF WHETHER TEKTRONIX OR THE VENDOR HAS ADVANCE NOTICE OF THE POSSIBILITY OF SUCH DAMAGES.

Table of Contents

General Safety Summary	v
Service Safety Summary	vii
Environmental Considerations	viii
Preface	x
Documentation	x
Conventions Used in this Manual	x
Returning the Probe for Servicing	xi
Key Features	1
Installation	2
Connecting to the Host Instrument	2
Degaussing the Probe	3
Probe Controls and Indicators	5
Functional Check	10
Basic Operation	11
Application Examples	13
Inductance Measurements	14
Measuring Inductor Turns Count	17
Accessories and Options	19
Using Standard Accessories	19

Optional Accessories	22
Options	25
Probing Principles	26
Degaussing a Probe with an Unpowered Conductor in the Jaws	26
Measuring Differential Current	27
Extending Current Range	29
Increasing Sensitivity	32
Common Mode Noise/Magnetic Field Errors	33
AC and DC Coupling	34
Maximum Current Limits	35
Specifications	39
Warranted Characteristics	40
Typical Characteristics	41
Nominal Characteristics	47
Certifications and Compliances	47
Performance Verification	50
Equipment Required	51
Making the DC Current Loop	52
Equipment Setup	53
DC Gain Accuracy	54
Rise Time and Bandwidth	59
Test Record	62

Adjustments	63
Equipment Required	63
Equipment Setup	63
DC Gain Accuracy	64
Maintenance	66
Troubleshooting	66
Cleaning	67
Repairing the Probe	68
Probe Head Disassembly	69
Replacement	72
Reassembly	76
Replaceable Parts	77
Index	

General Safety Summary

Review the following safety precautions to avoid injury and prevent damage to this product or any products connected to it.

To avoid potential hazards, use this product only as specified.

Only qualified personnel should perform service procedures.

To Avoid Fire or Personal Injury

Connect and Disconnect Properly. Do not connect or disconnect probes or test leads while they are connected to a voltage source.

Connect and Disconnect Properly. De-energize the circuit under test before connecting or disconnecting the current probe.

Connect and Disconnect Properly. Connect the probe output to the measurement instrument before connecting the probe to the circuit under test. Connect the probe reference lead to the circuit under test before connecting the probe input. Disconnect the probe input and the probe reference lead from the circuit under test before disconnecting the probe from the measurement instrument.

Observe All Terminal Ratings. To avoid fire or shock hazard, observe all ratings and markings on the product. Consult the product manual for further ratings information before making connections to the product.

Do not connect a current probe to any wire that carries voltages above the current probe voltage rating.

Do Not Operate Without Covers. Do not operate this product with covers or panels removed.

Do Not Operate With Suspected Failures. If you suspect that there is damage to this product, have it inspected by qualified service personnel.

Avoid Exposed Circuitry. Do not touch exposed connections and components when power is present.

Do Not Operate in Wet/Damp Conditions.

Do Not Operate in an Explosive Atmosphere.

Keep Product Surfaces Clean and Dry.

Terms in this Manual

These terms may appear in this manual:



WARNING. *Warning statements identify conditions or practices that could result in injury or loss of life.*



CAUTION. *Caution statements identify conditions or practices that could result in damage to this product or other property.*

Symbols and Terms on the Product

These terms may appear on the product:

- DANGER indicates an injury hazard immediately accessible as you read the marking.
- WARNING indicates an injury hazard not immediately accessible as you read the marking.
- CAUTION indicates a hazard to property including the product.

The following symbols may appear on the product:



Service Safety Summary

Only qualified personnel should perform service procedures. Read this *Service Safety Summary* and the *General Safety Summary* before performing any service procedures.

Do Not Service Alone. Do not perform internal service or adjustments of this product unless another person capable of rendering first aid and resuscitation is present.

Disconnect Power. To avoid electric shock, switch off the instrument power, then disconnect the power cord from the mains power.

Use Care When Servicing With Power On. Dangerous voltages or currents may exist in this product. Disconnect power, remove battery (if applicable), and disconnect test leads before removing protective panels, soldering, or replacing components.

To avoid electric shock, do not touch exposed connections.

Environmental Considerations

This section provides information about the environmental impact of the product.

Product End-of-Life Handling

Observe the following guidelines when recycling an instrument or component:

Equipment Recycling. Production of this equipment required the extraction and use of natural resources. The equipment may contain substances that could be harmful to the environment or human health if improperly handled at the product's end of life. In order to avoid release of such substances into the environment and to reduce the use of natural resources, we encourage you to recycle this product in an appropriate system that will ensure that most of the materials are reused or recycled appropriately.

The symbol shown below indicates that this product complies with the European Union's requirements according to Directive 2002/96/EC on waste electrical and electronic equipment (WEEE). For information about recycling options, check the Support/Service section of the Tektronix Web site (www.tektronix.com).



Restriction of Hazardous Substances

This product has been classified as Monitoring and Control equipment, and is outside the scope of the 2002/95/EC RoHS Directive. This product is known to contain lead, cadmium, mercury, and hexavalent chromium.

Preface

This manual describes the installation and operation of the TCP0030 current probe. Basic probe operations and concepts are presented in this manual. You can also access the Tektronix Web site for this document and other related information.

Documentation

To read about	Use these documents *
TCP0030 Probe: First Time Operation, Functional Check, Operating Basics, Specifications, Performance Verification	Read this Instruction Manual.
In-depth oscilloscope operation, user interface help, GPIB commands	Access the online help from the Help menu on the host instrument.

* To access the documentation that is installed on your instrument, click **Start** in the taskbar and select **Programs > TekApplications**.

Conventions Used in this Manual

The following icon is used throughout this manual to indicate a step sequence.



Returning the Probe for Servicing

If your probe requires servicing, you must return the probe to Tektronix. If the original packaging is unfit for use or not available, use the following packaging guidelines:

Preparation for Shipment

1. Use a corrugated cardboard shipping carton having inside dimensions at least one inch greater than the probe dimensions. The box should have a carton test strength of at least 200 pounds.
2. Put the probe into an antistatic bag or wrap it to protect it from dampness.
3. Place the probe into the box and stabilize it with light packing material.
4. Seal the carton with shipping tape.
5. Refer to *Contacting Tektronix* at the beginning of this manual for the shipping address.

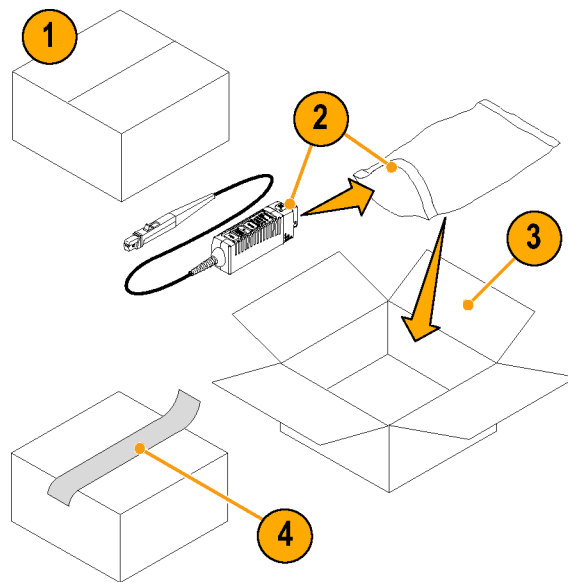

Key Features

You can use the TCP0030 current probe to make accurate measurements from DC to 120 MHz. The probe combines proven Hall-effect technology with the new Tektronix TekVPI oscilloscope interface. Key features include:

- >120 MHz bandwidth, <2.92 ns rise time
- AC/DC Measurement capability
- 50 A peak pulse current (pulse widths <10 μ s)
- 5 A and 30 A range settings
- 1 mA sensitivity (on TekVPI oscilloscopes that support the 1 mV/div setting)
- 1% DC Accuracy (typical)
- One-button degauss/autozeroing
- Probe control through the TekVPI oscilloscope menus or remotely through the oscilloscope
- Direct scaling and unit readout on host instruments
- AC coupling (on TekVPI oscilloscopes that support AC coupling)

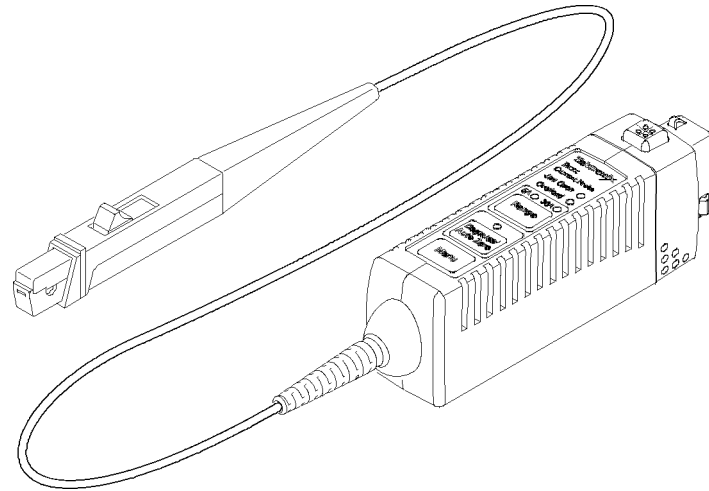

Installation

Connecting to the Host Instrument



CAUTION. The probe head is a precision assembly. Do not drop the probe or subject it to physical shock, strain, or sudden changes in ambient conditions. Do not insert conductors larger than 3.8 mm diameter into the probe jaw. Damage to the probe may result.

1. Slide the probe into the TekVPI receptacle. The probe snaps in when fully engaged.
2. To disconnect, press the latch button and pull the probe away from the instrument.

When the probe is connected, the host instrument reads information from the probe and identifies the device. All of the probe LEDs light briefly for a quick visual check.

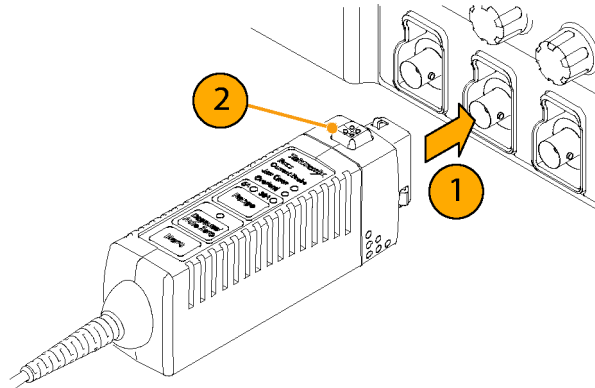

Degaussing the Probe

1. After the probe is identified by the host instrument, the screen display prompts you to run a degauss routine.

The multicolor Degauss/AutoZero status LED on the probe also indicates that a degauss is needed, by flashing red.

2. To degauss the probe, press the **Degauss/AutoZero** button on the probe or in the Degauss window on the host instrument.

NOTE. The DC gain and offset errors are not guaranteed when this LED flashes red.

3. The multicolor Degauss/AutoZero status LED glows green to indicate a successful degauss routine was run, and that the probe is in normal operating mode.

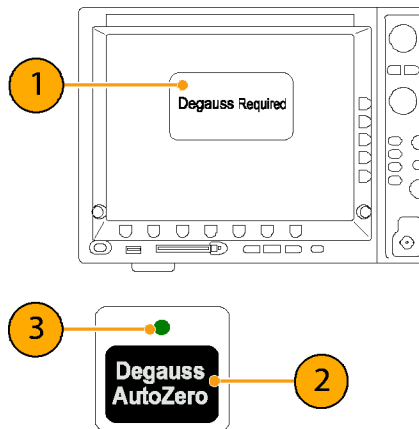

Quick Tip

To maintain measurement accuracy, degauss your probe in each of these cases:

- After you turn on the measurement system and allow a 20-minute warm-up period
- Before you connect the probe to a conductor
- Whenever a current or thermal overload condition occurs
- Whenever you subject the probe to a strong external magnetic field

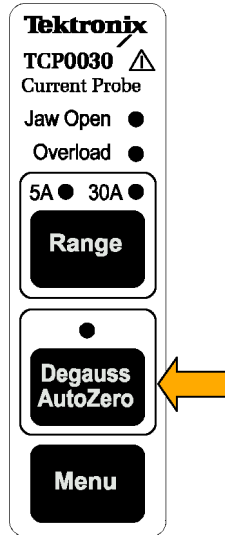

Probe Controls and Indicators

When the probe is powered on, all of the indicator LEDs light briefly, and at least two LEDs remain lighted—one to indicate the current range selected and one to display the Degauss/AutoZero status.

NOTE. The probe will retain the range state and will restore it when it is power cycled.

Jaw Open LED

1. If the Jaw Open LED glows, the probe slider is unlocked.
2. Lock the probe slider to accurately measure current or to degauss the probe.



CAUTION. Do not measure conductors larger than 3.8 mm diameter. Damage to the probe jaws may result.

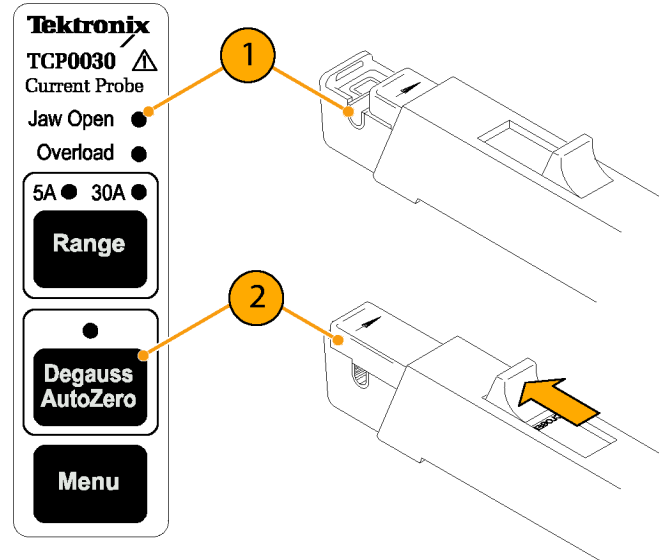

Overload LED

The multicolor Overload LED alerts you that the probe specifications are being exceeded. When the LED:

- Glows red, the maximum input continuous current limit has been exceeded
- Glows orange, the safe operating temperature of the probe has been exceeded
- Flashes red and orange, both the maximum input continuous current limit and the safe operating temperature of the probe have been exceeded



CAUTION. Do not subject the probe to conditions that cause the Overload LED to light for extended periods.

Quick Tip

- An input current overload can magnetize the probe. Always degauss the probe after an overload.

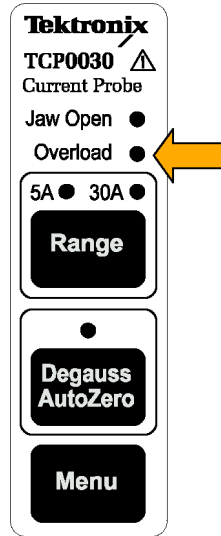

Range Button

1. Press the **Range** button to select between the 5 A and 30 A current range settings. The green LEDs indicate the range selected. The range and units are also displayed on the oscilloscope screen.

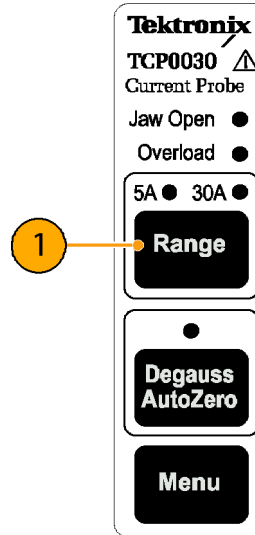

Degauss/AutoZero

When the multicolor Degauss/AutoZero status LED flashes red, you must degauss the probe. If the LED flashes orange, you should degauss the probe. The DC gain and offset errors are not guaranteed when this LED flashes orange.

The Degauss/AutoZero function also clears (AutoZeroes) any DC offset in the probe.

To degauss the probe, do the following:

1. Disconnect the probe from the current source.
2. Press the Degauss/AutoZero button to initiate the degauss routine.

The LED glows green after successfully completing the Degauss/AutoZero routine.

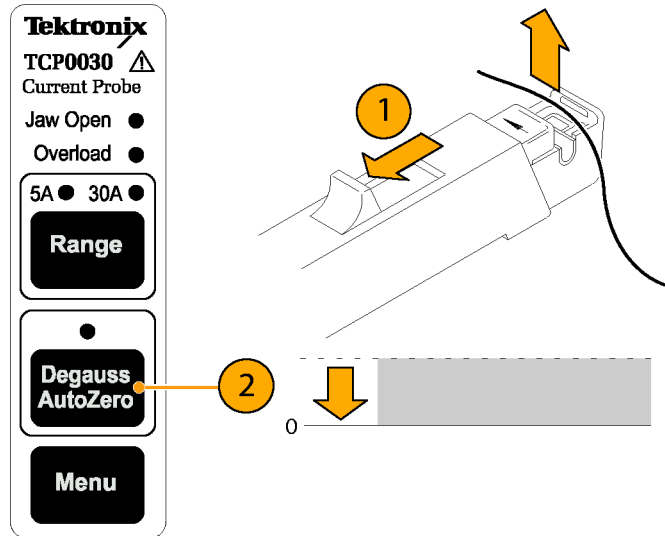

Menu Button

1. Press the **Menu** button to display the Probe Setup screen on the oscilloscope.

Use this screen to check or change the settings on your probe.

NOTE. The Probe Setup screen may include buttons to access other probe information, depending on the oscilloscope model.

2. Press the **Menu** button again to close the Probe Setup screen.

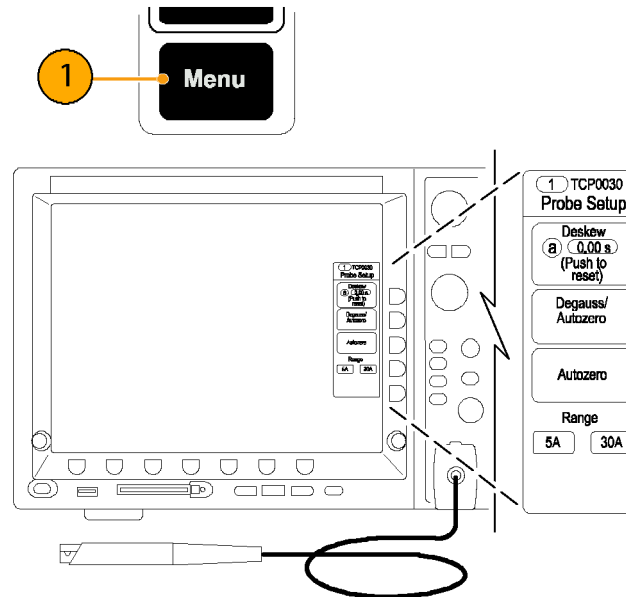

Functional Check

The following procedure checks that your probe is functioning properly. To verify that your probe meets the warranted specifications, refer to the *Performance Verification* procedures. (See page 50.)



CAUTION. The probe jaw opening accommodates insulated conductors with a diameter of 3.8 mm or less. Do not insert conductors larger than 3.8 mm diameter into the probe jaw. Damage to the probe may result.

To check that your probe functions correctly, do the following:

1. Connect the probe to any channel of the oscilloscope.
2. Press the Degauss/AutoZero button.
3. Clamp the probe to your circuit.
4. Set the oscilloscope to display the probe channel.
5. Adjust the oscilloscope or use the Autoset function to display a stable waveform.
When you see a stable waveform, your probe is functioning correctly.

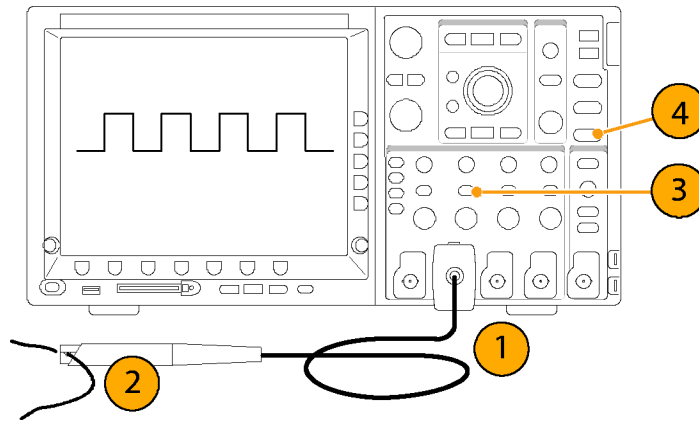

Basic Operation



CAUTION. Do not force conductors larger than 3.8 mm into the probe jaws. Damage to the probe may result.

The mating surfaces of the probe head transformer are precision-polished and should be handled with care. Measurements may be degraded by dirt on the mating surfaces of the probe head transformer. Refer to the Maintenance section of this manual for information on how to properly clean the probe head transformer surfaces.

1. Check the oscilloscope display before connecting the probe to a conductor.
If there is a DC offset, degauss the probe.
(See page 3, *Degaussing the Probe.*)
2. Close and lock the probe jaw over the conductor.
For correct polarity reading, connect the probe so that the current flow, from positive to negative, is aligned with the arrow on the probe jaw.
3. Read the measurement on the oscilloscope display.

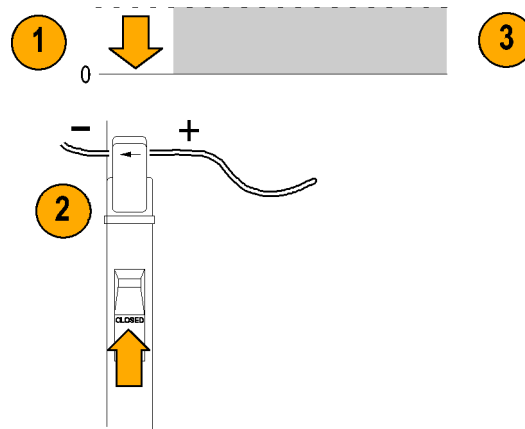

Grounding the Probe

Use the Ground Lead to improve EMI rejection at high frequencies.

1. Clip the Ground Lead to the ground post at the bottom of the probe head.
2. Connect the alligator end of the clip to the DUT chassis ground.

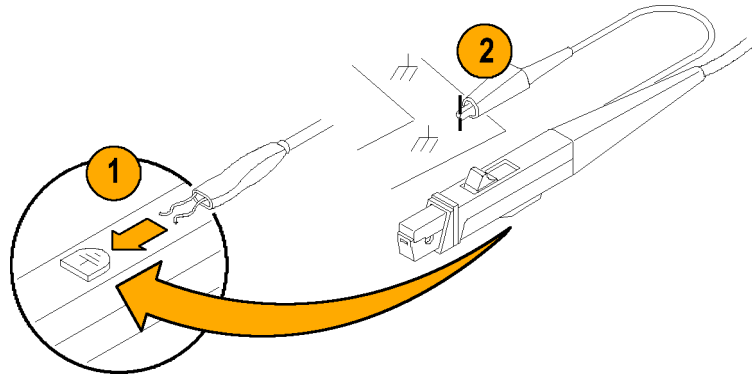

Application Examples

This section explains ways to use your probe in common troubleshooting tasks and how to extend the use of your measurement system.

Inductance Measurements

You can use the current probe to measure the inductance of coils that have either a low-impedance or high-impedance pulse source of a known value.

Low-Impedance Pulse Sources

This figure shows a constant-voltage pulse generator of extremely low output impedance connected to an inductor that has low resistance.

1. Connect the inductor across the output terminals of the pulse generator.
2. Maintain a constant voltage across the inductor.
3. Clamp the current probe over one of the source leads.

NOTE. If the probe impedance is a significant part of the total circuit inductance, measurement accuracy will be affected. Refer to the probe specifications for probe insertion impedance.

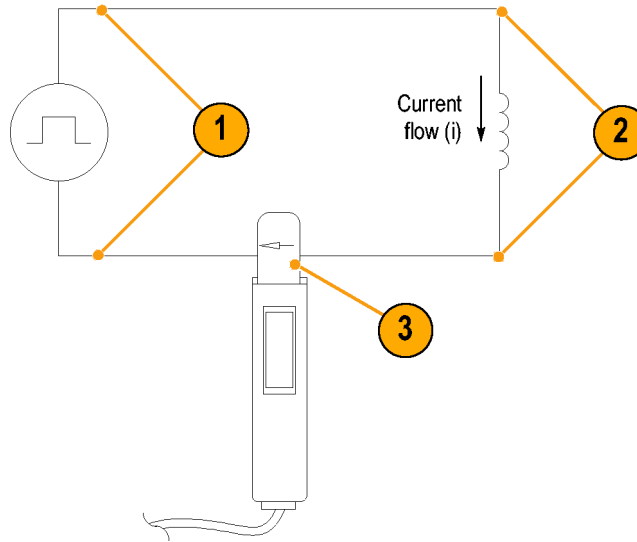

4. Measure the current ramp. The inductance is effectively defined by the slope of the current ramp shown here.
5. Calculate the inductance using the following formula:

$$L = \frac{-E}{\frac{di}{dt}}$$

where:

L is the inductance in henries,
 E is the voltage of the pulse generator,
 dt is the change in time, and
 di is the change in current.

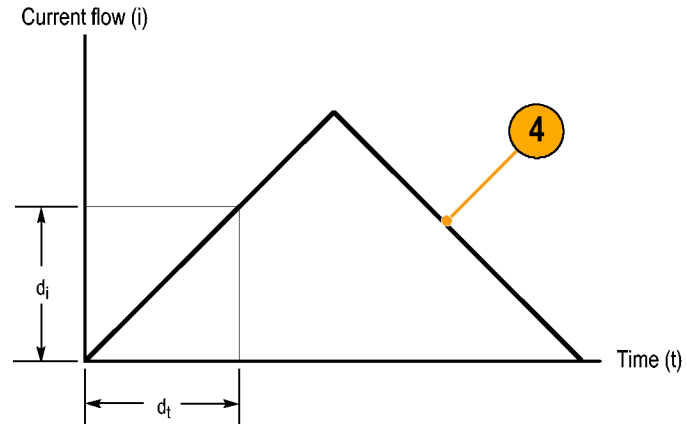

High-Impedance Pulse Sources

If the pulse source has a higher impedance of known resistance, such that the output voltage drops as the current increases, the inductance of a coil can be calculated by the time constant of the charge curve.

The current ramp shows how the values for the inductance formula are obtained.

Use this formula to calculate the inductance based on the current measurement:

$$L = \tau R$$

where:

L is the inductance in henries,
 τ is the time required for the current to rise or fall 63.2% of the total current value, and
 R is the source resistance of the pulse generator.

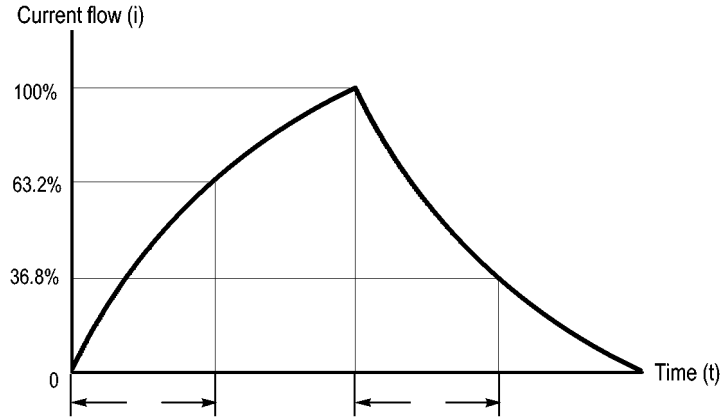

Measuring Inductor Turns Count

To obtain an approximate turns count of an inductor, do the following:

1. Connect the inductor to a current limited source, as shown.
2. Measure the input current on one of the inductor leads.
3. Clamp the current probe around the inductor and note the current value.

The number of turns is equal to the ratio of coil current to input current.

The accuracy of this method is limited by the current measurement accuracy.

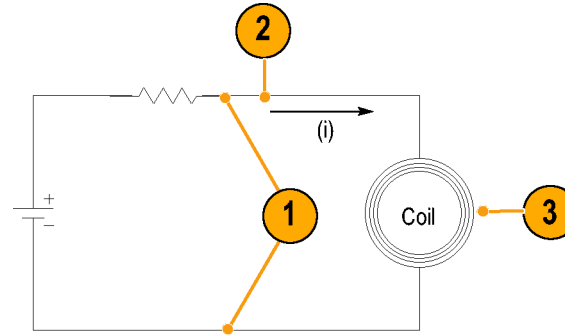

For a more precise turns count, you need a coil with a known number of turns to use as a reference. Do the following:

1. Repeat steps 1 and 2 above and make the following changes:
2. Insert the reference coil into the current probe.
3. Insert the test coil into the current probe so that the currents oppose each other as shown. You must observe the polarity of coil current to determine whether the test coil has less or more turns than the reference coil. The turns are calculated by using the formula:

$$N_2 = N_1 \times (I_m \div I_1)$$

where:

N_2 is the number of turns in the test coil,
 N_1 is the number of turns in the reference coil,
 I_m is the measured coil current, and
 I_1 is the input current.

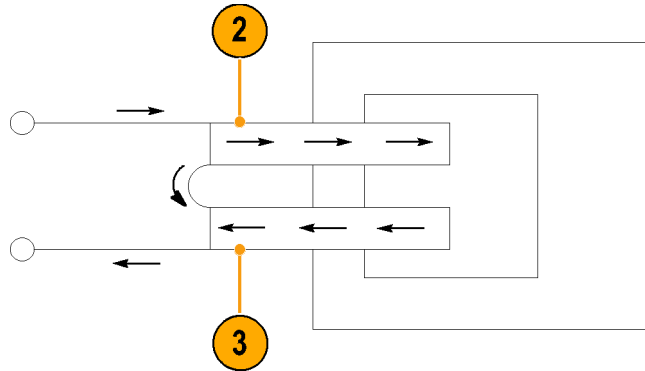

Accessories and Options

This section lists the standard accessories and provides information on how to use the accessories. Specifications are provided where appropriate so that you can choose the accessory that best fits your needs.

Using Standard Accessories

Probe Ground Lead

1. Fasten the small clip to the ground stub on the probe body.
2. Clip the alligator clip to your circuit.
3. Attach the probe to your circuit.

Reorder Tektronix part number 196-3120-XX,
qty. 1.

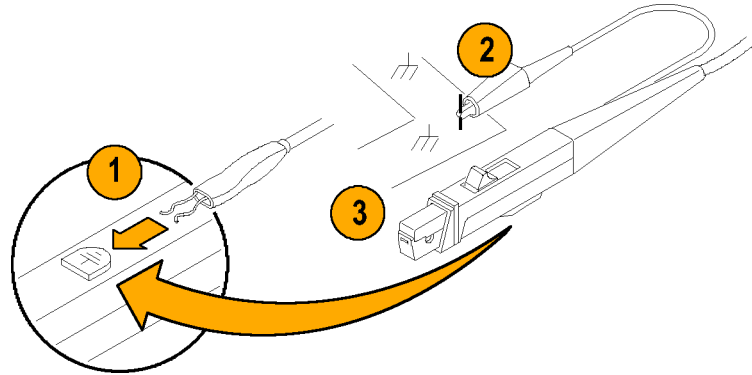

Nylon Carrying Case with Pouch and Inserts

Use the carrying case to hold the probe, the accessories, and the Instruction Manual.

1. Place the probe, accessories, and manual in the carrying case.
2. Close the carrying case to transport the accessories to another location or for storage.

Reorder Tektronix part number: 016-1952-XX

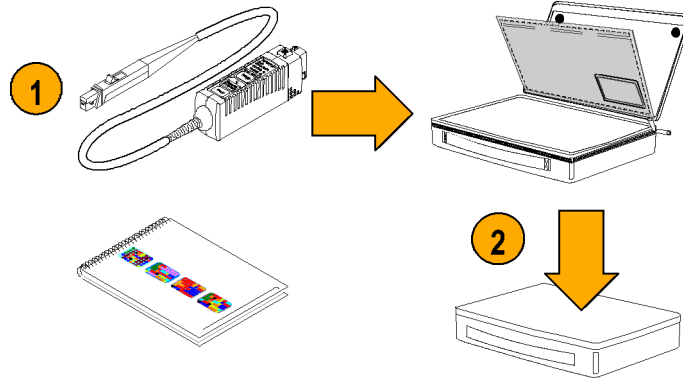

Protective Cover

At your workbench, put the probe in the padded protective cover to prevent accidental damage to the probe.

1. Insert the probe in the protective cover.
2. Close the protective cover with the strap to secure the cover to the probe.

Reorder Tektronix part number: 016-1923-XX

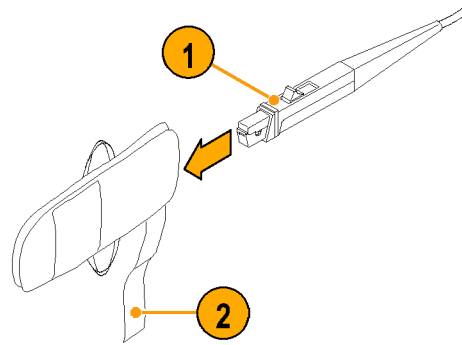

Instruction Manual

The instruction manual provides operating and maintenance instructions.

Reorder Tektronix part number:

- 071-1812-XX (English)
- 071-1813-XX (Japanese)
- 071-1814-XX (Simplified Chinese)

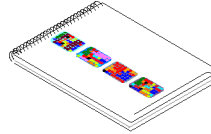

Optional Accessories

This section lists the optional accessories that you can purchase to help you with your probing tasks.

Current Loop

Use the 1-turn, 50 Ω current loop for the performance verification procedures. The BNC connector allows for easy connections to current sources.

Reorder Tektronix part number: 015-0601-50

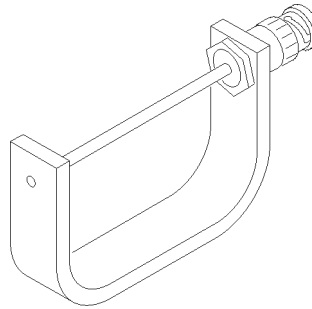

1. Connect the current loop to the current supply.
2. Connect the probe to the loop.
3. Power on the current supply.
4. Follow the procedure for the specific task that you are performing (for example, Performance Verification or Adjustments).

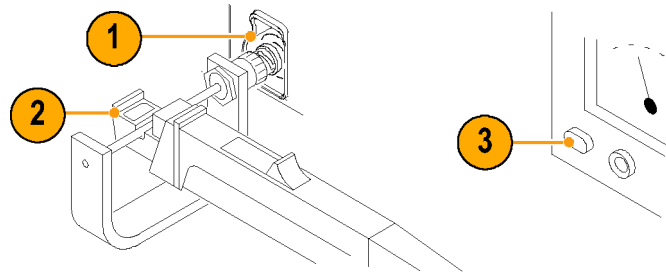

CT-4 High-Current Transformer

Use the CT-4 transformer with the TCP0030 current probe to provide step-down ratios of 20:1 or 1000:1. The CT-4 provides a means to measure high-amplitude AC currents.

1. Clamp the CT-4 transformer around the conductor you that want to test.
2. Clamp the TCP0030 Probe onto the measurement port on the back of the CT-4.
3. Proceed with your measurements.

Reorder Tektronix part number: CT-4

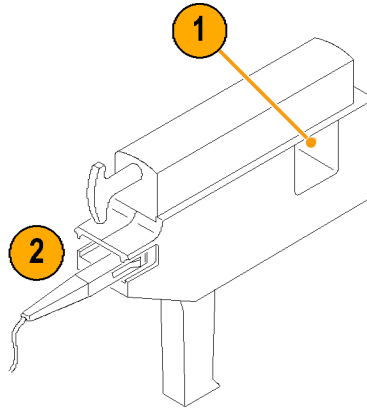

Deskew/Calibration Fixture

Connect this fixture to host instruments that support the probe calibration or deskew procedures. The deskew procedures compensate for gain errors and timing differences between current and voltage probes. Refer to your oscilloscope manual or fixture documentation for instructions.

Reorder Tektronix part number: 067-1686-00

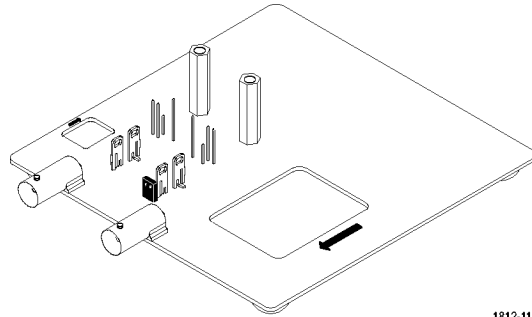

1812-118

Compensation Box Tool

Use this tool to open the compensation box when servicing the probe (replacing the switch panel, cable, or compensation box). Refer to the compensation box replacement procedures for instructions for using the tool.

Reorder Tektronix part number: 003-1892-00

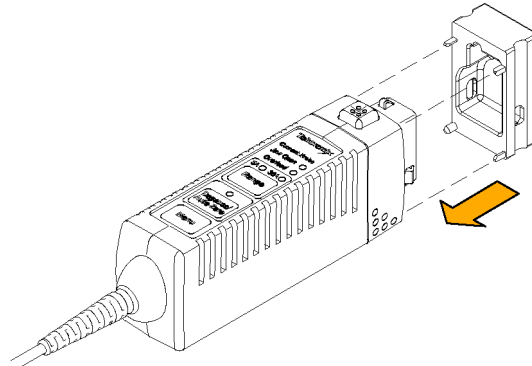

Options

Service Options

- **Option CA1.** Provides coverage for a single Calibration Event
- **Option C3.** Calibration Service 3 years
- **Option C5.** Calibration Service 5 years
- **Option D1.** Calibration Data Report
- **Option D3.** Calibration Data Report, 3 years (with Option C3)
- **Option D5.** Calibration Data Report, 5 years (with Option C5)
- **Option R3.** Repair Service 3 years
- **Option R5.** Repair Service 5 years

Manual Options

- **Option L0.** English language Instruction Manual
- **Option L5.** Japanese language Instruction Manual
- **Option L7.** Simplified Chinese language Instruction Manual

Probing Principles

The following information is provided to help you use the full potential of your current probe.

Degaussing a Probe with an Unpowered Conductor in the Jaws

You can degauss your current probe while a conductor of an unpowered circuit is clamped in the jaws. The advantage of degaussing with an unpowered circuit is that any offset from stray DC magnetic fields is compensated. Degaussing with the conductor in the probe jaws eliminates the need to manually remove the probe.

NOTE. *Be certain that the conductor in the probe jaws is completely unpowered. Any current flowing through the conductor will cause a residual offset in the current probe and may cause an inaccurate measurement or an error condition.*

The impedance of your circuit must be higher than 10 m Ω for the degauss procedure to work. (The probe core will not saturate with a circuit impedance of less than 10 m Ω). While degauss occurs, the probe will induce a 60 mV, 200 Hz signal in the unpowered circuit. Your circuit must be able to absorb this induced voltage. With low impedance circuits, several amperes may be induced in the circuit being measured. This may be of concern when you are using very small conductors.

Measuring Differential Current

To simplify your differential or null current measurements, you can place two conductors in one current probe.

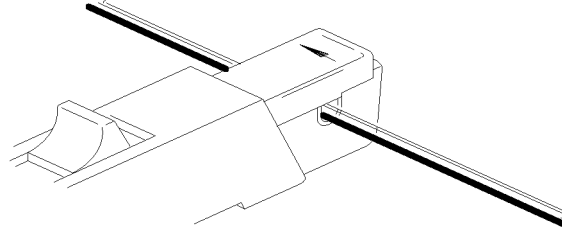

WARNING. Do not put uninsulated conductors in the probe. An uninsulated conductor is any conductor without insulation or without insulation rated for the voltage present on the conductor under test.

An insulated conductor is any conductor that is surrounded by an insulating material that is capable of isolating the voltage present on the conductor. Lacquer coatings like those typically found on transformer windings do not provide sufficient, reliable insulation for use with current probes. The lacquer coating can be easily nicked or damaged, compromising the insulating capabilities of the lacquer coating.

Do not force the slide closed. Damage to the probe may result. If you cannot close the slide around the conductor(s), either reduce the number of conductors you are measuring, or, if possible, take your measurement on a smaller conductor.

1. Orient the two conductors under test so that the polarities (+ and -) oppose each other.
2. Clamp the current probe around the two conductors. Be careful not to pinch a conductor in the probe jaws.

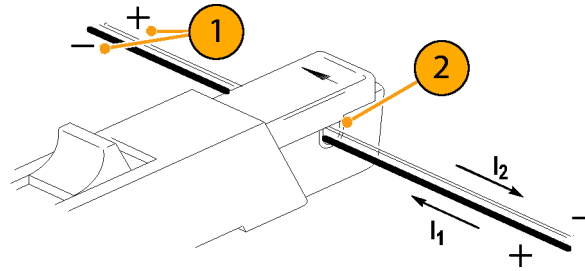

3. Measure the current.
Conventional current flows from positive to negative. A waveform above the baseline indicates that the conductor with the conventional current flow in the direction of the probe arrow is carrying the greater current.

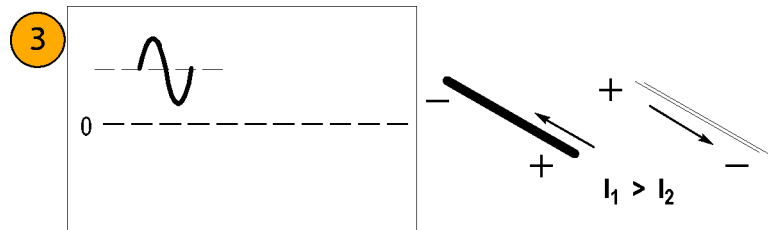

4. To adjust for a current null, adjust the current in one of the conductors until the displayed measurement is zero.

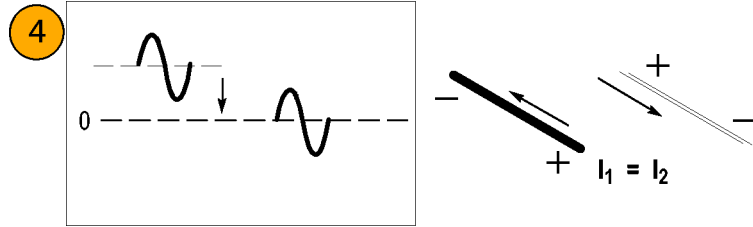

Extending Current Range

If your measurement exceeds the maximum current rating of the connected probe, you can extend the AC and DC current ranges without exceeding specified limits by using the following methods.



WARNING. To avoid personal injury or equipment damage, do not exceed the specified electrical limits of the probe or any applicable accessories. When using multiple conductors, do not exceed current limits on either conductor.

Extending DC Range

If you want to measure a low-amplitude AC component that is superimposed on an extremely large steady-state DC component (such as in a power supply), or if you want to extend the DC current range of your probe, you can add offset (bucking) current with a second conductor.



WARNING. Do not put more than one uninsulated conductor at a time in the probe jaws. An uninsulated conductor is any conductor without insulation or without insulation rated for the voltage present on the conductor under test.

To supply additional bucking current:

1. Place a second conductor that has a pure DC component of known value in the probe jaw with the conductor under test.
2. Orient the second conductor so that the bucking current flows in the opposite direction of the DC flow in the conductor under test.
3. To determine measurement values, add the value of the bucking current to the displayed measurement.

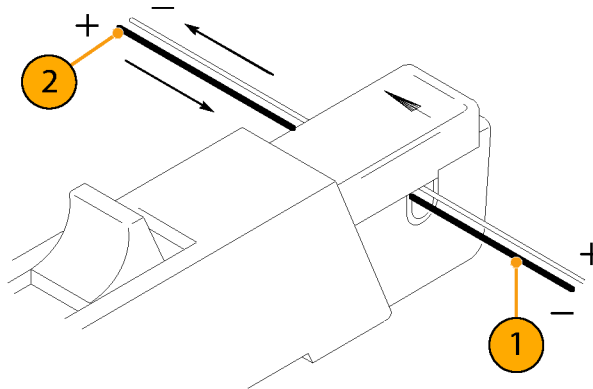

NOTE. Adding a second conductor to the probe increases the insertion impedance and reduces the upper bandwidth limit of the probe. Winding multiple turns further increases the insertion impedance, further reducing the upper bandwidth limit.

To increase the value of the bucking current:

1. Wind multiple turns of the second conductor around the probe.

The bucking current is equal to the current flowing in the conductor, multiplied by the number of turns wound around the probe.

For example, if the second conductor has a current of 100 mA DC and is wrapped around the probe five times, the DC bucking current is 100 mA multiplied by 5, or 500 mA DC.

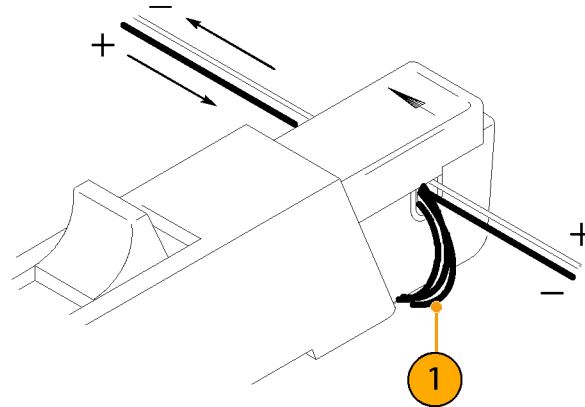

Increasing Sensitivity

If you are measuring DC or low-frequency AC signals of very small amplitudes, you can increase measurement sensitivity of your Current Probe by doing the following:

1. Wind several turns of the conductor under test around the probe as shown. The signal is multiplied by the number of turns around the probe.
2. To obtain the actual current value, divide the displayed amplitude by the number of turns.

For example, if a conductor is wrapped around the probe three times and the oscilloscope shows a reading of 3 mA DC, the actual current flow is 3 mA divided by 3, or 1 mA DC.

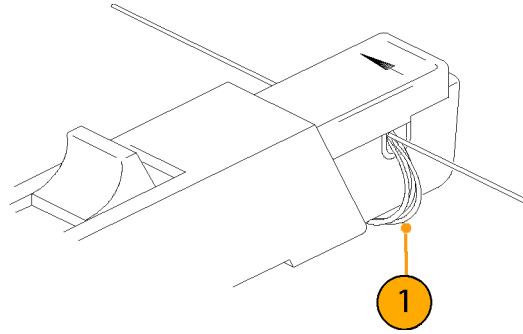

NOTE. *Winding more turns around the probe increases the insertion impedance and reduces the upper bandwidth limit of the probe.*

Common Mode Noise/Magnetic Field Errors

Common-mode noise at high frequencies and strong magnetic fields on the supply side of your circuit can cause measurement errors. To avoid this:

1. Measure on the low or ground side of your circuit.
2. Orient the probe to measure conventional current flow.

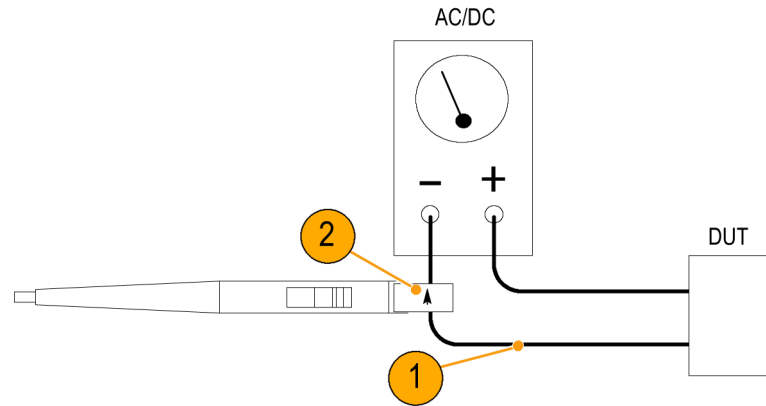

AC and DC Coupling

You can couple the signal input to the oscilloscope with either DC or AC coupling. DC coupling shows both the DC and AC measurement components. AC coupling removes the DC component from the displayed signal.

1. This low-frequency square wave is displayed using AC coupling. The signal exhibits low-frequency rolloff.
2. Press the DC Coupling button to display the waveform as truly square.

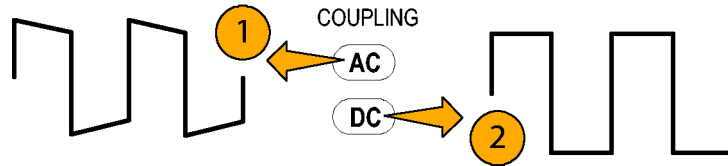

CAUTION. When you use AC coupling, make sure that the input DC current does not exceed the probe specifications.

Maximum Current Limits

Current probes have three maximum current ratings: pulsed, continuous, and Ampere-second product. Exceeding any of these ratings can saturate the probe core, which magnetizes the core and causes measurement errors. Refer to the specifications for the maximum current ratings of the probe. (See Table 2 on page 41.)

- Maximum Pulsed Current ($I_{\max P}$) is the maximum peak value of pulsed current the probe can accurately measure, regardless of how short (within bandwidth limitations) the pulse duration is.
- Maximum Continuous Current ($I_{\max C}$) is the maximum current that can be continuously measured at DC or at a specified AC frequency. The maximum continuous current value is derated with frequency; as the frequency increases, the maximum continuous current rating decreases.

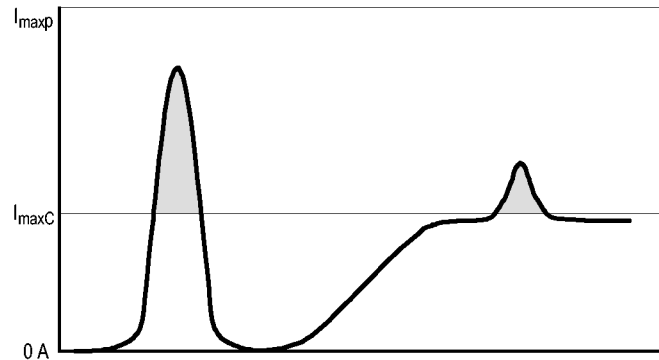

- Ampere-Second Product is the maximum width of pulsed current that you can measure when the pulse amplitude is between the maximum continuous and maximum pulsed current specifications. The maximum continuous specification varies by frequency.

To determine if your measurement exceeds the Ampere-second product, you must first determine the maximum allowable pulse width or maximum allowable pulse amplitude, as described in the following section.

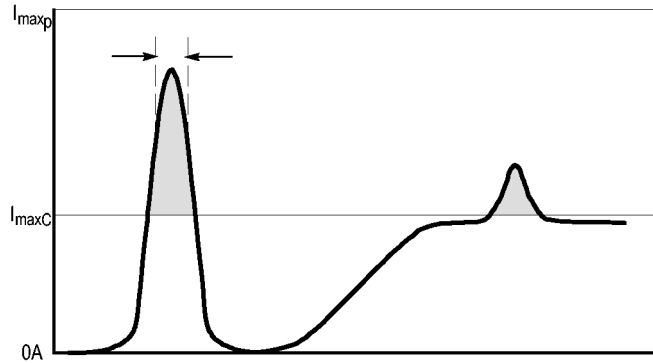

NOTE. Always degauss the probe after measuring a current that exceeds the maximum continuous current, maximum pulsed current, or Ampere-second product rating of the probe. Exceeding these ratings can magnetize the probe and cause measurement errors.

Maximum Allowable Pulse Width

To determine the maximum allowable pulse width do the following:

1. Measure the peak current of the pulse.
2. Divide the Ampere-second (or Ampere-microsecond) specification for the range setting of the TCP0030 probe by the measured peak current of the pulse:

$$\frac{A \cdot \mu s}{I_P} = PW_{max}$$

The quotient is the maximum allowable pulse width (PW_{max}).

3. Check that the pulse width at the 50% point of the measured signal is less than the calculated maximum allowable pulse width (PW_{max}).

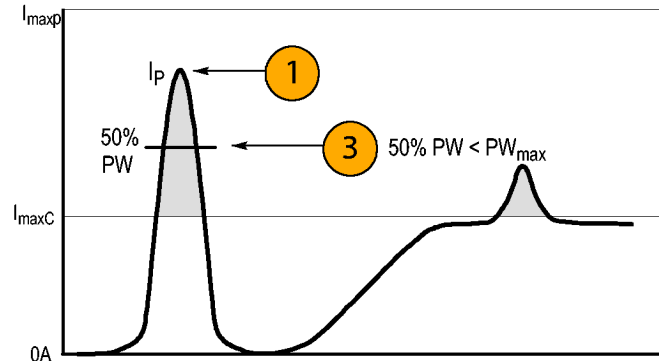

Maximum Allowable Pulse Amplitude

To determine the maximum allowable pulse amplitude do the following:

1. Measure the pulse width at the 50% points.
2. Divide the Ampere-second (or Ampere-microsecond) specification for the range setting of the TCP0030 probe by the pulse width.

The quotient is the maximum allowable pulse amplitude; the peak amplitude of the measured pulse must be less than this value.

For example, the TCP0030 probe has a maximum Ampere-second product of 500 A-ms in the 30 A range setting. If a pulse measured with the probe has a width of 11 ms, the maximum allowable peak current would be 500 A-ms divided by 11 ms, or 45.5 A.

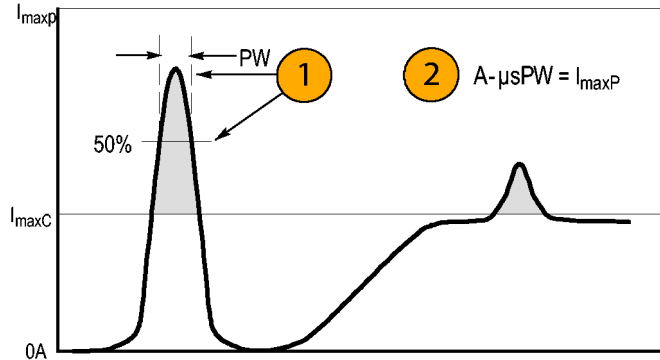

Specifications

The specifications in Tables 1 through 5 are valid under the following conditions:

- The probe has been calibrated at an ambient temperature of $23\text{ }^{\circ}\text{C} \pm 5\text{ }^{\circ}\text{C}$.
- The probe is connected to a host instrument with an input impedance of $1\text{ M}\ \Omega$.
- The probe must have a warm-up period of at least 20 minutes and be in an environment that does not exceed the limits described. (See Table 1).

Specifications for the TCP0030 current probe fall into three categories: warranted, typical, and nominal characteristics.

Warranted Characteristics

Warranted characteristics describe guaranteed performance within tolerance limits or certain type-tested requirements. Warranted characteristics that have checks in the *Performance Verification* section are marked with the ✓ symbol.

Table 1: Warranted electrical characteristics

Characteristic	Description
✓ DC gain accuracy	<3% (typical <1% at +23 °C, ± 5 °C)
✓ Rise time (10% to 90%)	≤2.92 ns
✓ Bandwidth	DC to 120 MHz

Typical Characteristics

Typical characteristics describe typical but not guaranteed performance.

Table 2: Typical electrical characteristics

Characteristic	Description
Maximum continuous current — DC and Low frequency (See Figure 3.)	5 A Range: 5 A RMS 30 A Range: 30 A RMS
Maximum peak current (See Figure 3.)	50 A maximum peak pulse
Displayed RMS Noise	≤75 μA RMS. (Limit measurement bandwidth to 20 MHz)
Insertion impedance	(See Figure 2.)
Aberrations	<50 ns: ≤10% p-p >50 ns: ≤5% p-p
Signal delay	~14.5 ns
Maximum voltage on bare wire	Use on insulated conductors only
Maximum Amp·Second product (See graph on page 49.)	5 A Range: 50 A·μs 30 A Range: 500 A·μs

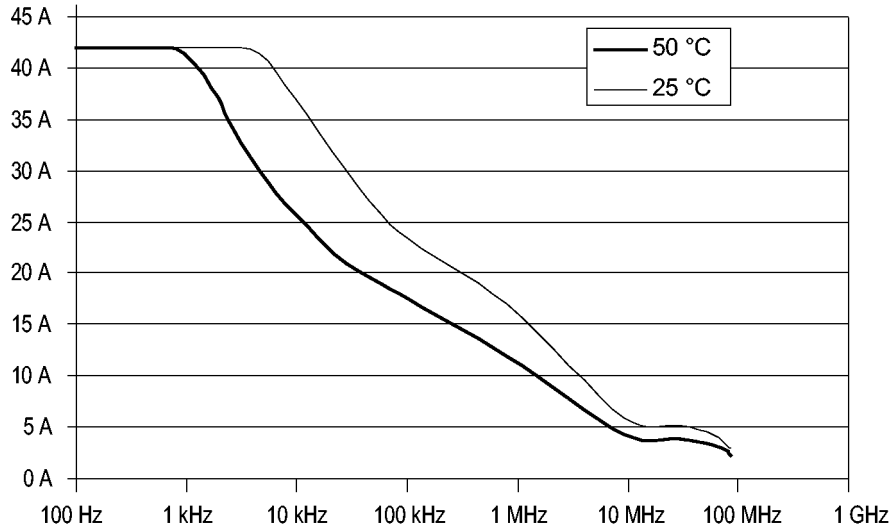

Figure 1: Frequency derating (peak current versus frequency)

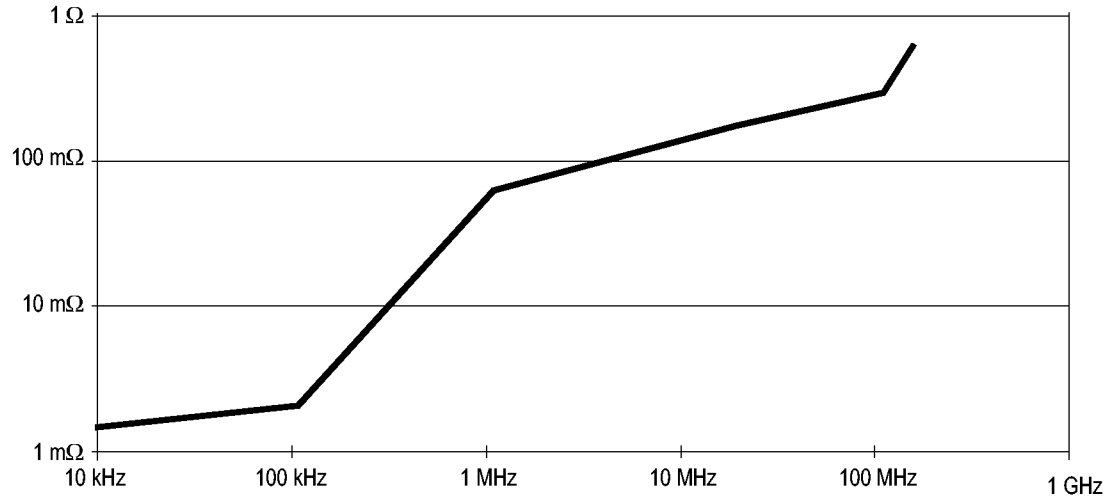

Figure 2: Typical differential input impedance versus frequency

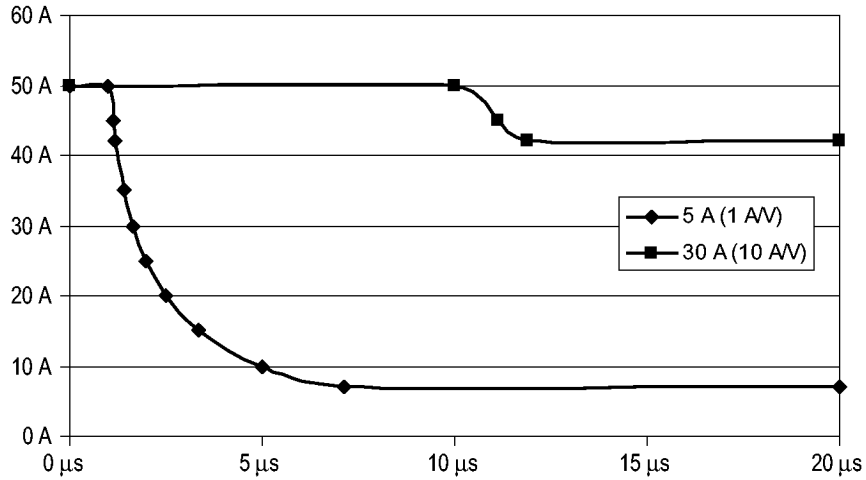

Figure 3: Maximum peak pulse versus pulse width

Table 3: Environmental characteristics

Characteristic	Description
Temperature	Operating: 0 to +50 °C (+32 to +122 °F) Nonoperating: -40 to +75 °C (-40 to +167 °F)
Humidity	Operating: 5-95% RH, tested up to +30 °C (+86 °F) 5-85% RH, tested at +30 °C to +50 °C (+86 °F to +122 °F) Nonoperating: 5-95% RH, tested up to +30 °C (+86 °F) 5-85% RH, tested at +30 °C to +75 °C (+86 °F to +167 °F)
Altitude	Operating: Up to 3000 meters (10,000 feet), Nonoperating: Up to 12,192 meters (40,000 feet)

Table 4: Typical mechanical characteristics

Characteristic	Description
Dimensions, compensation box	107 mm × 41 mm × 26 mm (4.2 in × 1.6 in × 1.0 in)
Dimensions, probe head	197 mm × 1.6 cm × 3.2 cm (7.77 in × 0.625 in × 1.25 in)
Dimensions, cable length	2 m (79 in) (from the probe head to the compensation box)
Unit weight	1.550 g (3.44 lbs) (probe, accessories, and packaging)

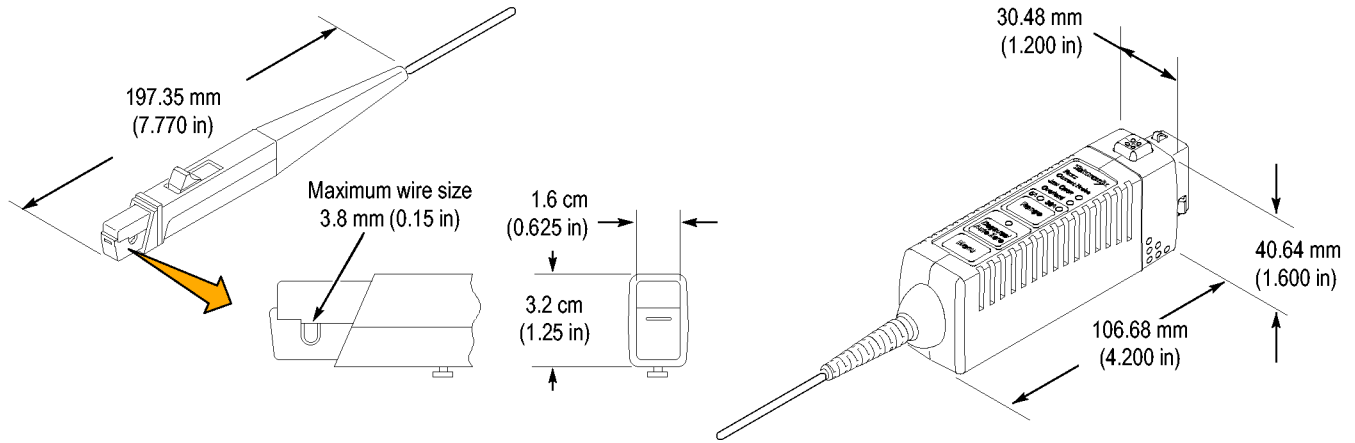

Nominal Characteristics

Nominal characteristics describe guaranteed traits, but the traits do not have tolerance limits.

Table 5: Nominal electrical characteristics

Characteristic	Description
Input coupling	DC
Current ranges	5 A and 30 A
Termination	Terminate output into 1 M Ω
Compatibility	Oscilloscopes equipped with the TekVPI interface

Certifications and Compliances

EC Declaration of Conformity - Low Voltage

Compliance was demonstrated to the following specification as listed in the Official Journal of the European Communities:

Low Voltage Directive 73/23/EEC, amended by 93/68/EEC.

- EN 61010-1:2001. Safety requirements for electrical equipment for measurement control and laboratory use.
- EN 61010-2-032:2002. Particular requirements for handheld current clamps for electrical measurement and test equipment.

U.S. Nationally Recognized Testing Laboratory Listing

- UL 61010B-1:2003. Standard for electrical measuring and test equipment.
- UL 6010B-2-032:2003. Particular requirements for handheld current clamps for electrical measurement and test equipment.

Canadian Certification

- CAN/CSA C22.2 No. 1010.1:1997. Particular requirements for electrical equipment for measurement, control, and laboratory use. Part 1.
- CAN/CSA C22.2 No. 1010.2.032-96, Particular Requirements for Hand Held Current Clamps for Electrical Measurement and Test.

Additional Compliance

- IEC 61010-1:2001. Safety requirements for electrical equipment for measurement, control, and laboratory use.
- IEC 61010-2-032:2002. Particular requirements for handheld current clamps for electrical measurement and test equipment.

Equipment Type

Test and measuring equipment.

Pollution Degree Descriptions

A measure of the contaminants that could occur in the environment around and within a product. Typically the internal environment inside a product is considered to be the same as the external. Products should be used only in the environment for which they are rated.

- Pollution Degree 1. No pollution or only dry, nonconductive pollution occurs. Products in this category are generally encapsulated, hermetically sealed, or located in clean rooms.
- Pollution Degree 2. Normally only dry, nonconductive pollution occurs. Occasionally a temporary conductivity that is caused by condensation must be expected. This location is a typical office/home environment. Temporary condensation occurs only when the product is out of service.
- Pollution Degree 3. Conductive pollution, or dry, nonconductive pollution that becomes conductive due to condensation. These are sheltered locations where neither temperature nor humidity is controlled. The area is protected from direct sunshine, rain, or direct wind.
- Pollution Degree 4. Pollution that generates persistent conductivity through conductive dust, rain, or snow. Typical outdoor locations.

Pollution Degree

Pollution Degree 2 (as defined in IEC 61010-1). Note: Rated for indoor use only.

Performance Verification

The procedures that follow verify the warranted specifications of the probe, listed below. The recommended calibration interval is one year.

- DC gain accuracy
- Rise time
- Bandwidth

Perform the following verification procedures in the order listed.

Equipment Required

Table 6 lists the equipment required for the performance verification procedure.

Table 6: Test equipment

Description and quantity	Performance requirement	Recommended example ¹
Oscilloscope	TekVPI interface, 500 MHz or greater bandwidth	Tektronix DPO4000
High Amplitude Pulse Generator	Risetime <500 ps, pulse width >100 ns, amplitude >10 V _{pp} into 50 Ω	Picosecond Labs 2600
Calibrator	DCV: 0.2% accuracy, 0 to ±1.5 V, square wave output ACA: 0.25% accuracy, 0 to ±6 A, square wave output	Wavetek 9100
DC Current loop	5 turns 18 AWG coated wire on 3 inch form	See instructions that follow
HF Current loop	50 Ω ±0.5%, BNC male	015-0601-50
BNC-to-Dual banana adapter		103-0090-00
BNC Cable	50 Ω , 0.76 m (30 in) length	012-0117-00

¹ Nine-digit part numbers (xxx-xxxx-xx) are Tektronix part numbers.

Making the DC Current Loop

Construct the loop using #18 coated wire and a cylindrical form approximately 3 inches in diameter:

1. Wind *exactly* 5 turns of #18 coated wire around the form.
2. Scrape about a half-inch of coating off of the ends of the wire.

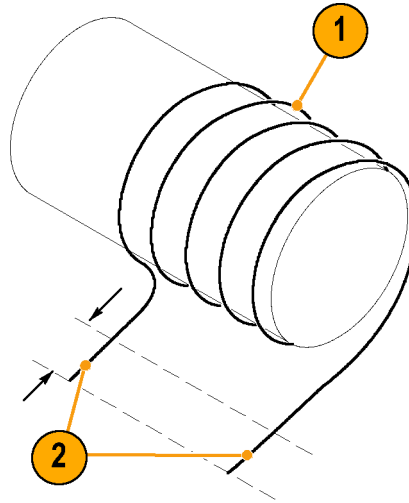

NOTE. Ensure that the current loop has exactly 5 turns. A significant error will result for each turn variance from 5 turns.

Equipment Setup

Use the following procedure to set up and warm up the equipment to test the probe.

1. Turn on the oscilloscope.
2. Connect the probe to any channel of the oscilloscope.
3. Press the Degauss/Autozero button.
4. Set the oscilloscope coupling to DC.
5. Power on the current source and the pulse generator.
6. Allow 20 minutes for the equipment to warm up.
7. Photocopy the test record and use it to record the test results. (See page 62.)

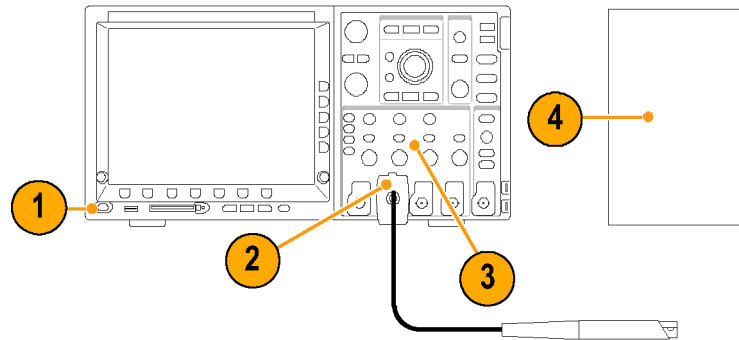

DC Gain Accuracy

This test checks the DC gain accuracy of the probe by first measuring the DC gain accuracy of the oscilloscope and then subtracting that value from the probe gain accuracy measurement. If the measurements are out of the specified limits in the test record, refer to the *Adjustments* section. (See page 63.)

Measure the Oscilloscope Gain

1. Connect a BNC-to-Dual Banana adapter to the voltage output terminals of the calibrator.
2. Connect a BNC cable between the adapter and the oscilloscope. (Leave the probe connected to keep it warmed up.)
3. Set the oscilloscope:
 - Vertical sensitivity to 500 mV/div
 - Vertical position and offset to 0.0 V
 - Horizontal to 400 or 500 us/div, trigger 50%
 - Acquisition mode to average 16
 - Input to 1 M Ω and coupling to DC
 - Automeasurement to display AMPLITUDE

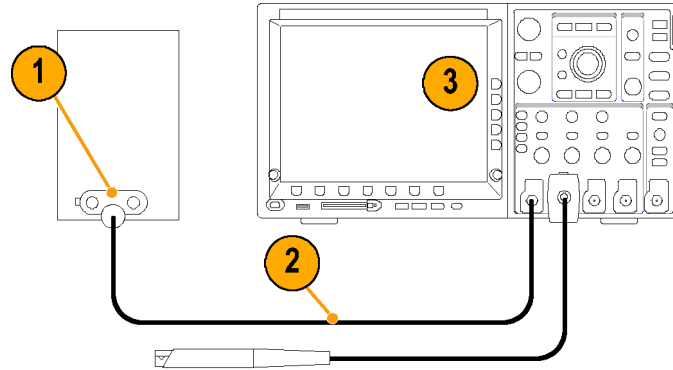

4. Set the calibrator to 1.5 Vpk (3.0 Vp-p) @500 Hz squarewave.
5. Enable the output of the calibrator.
6. Measure the output amplitude (a).

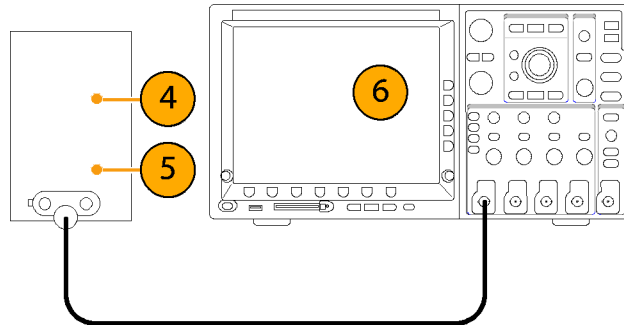

7. Calculate the oscilloscope DC gain accuracy (b) using the measured amplitude value from step 6 and the formula shown. Use the result to calculate the probe DC gain accuracy in step 19.
8. Disable the calibrator output.
9. Remove the BNC cable from the test setup.

7

$$b = \frac{[a (V_{pp}) - 3 V_{pp}]}{3 V_{pp}} \times 100$$

Example:

$$\frac{2.98 V_{pp} - 3 V_{pp}}{3 V_{pp}} \times 100 = -0.67\%$$

Measure the Probe Gain

10. Connect the probe to the oscilloscope channel you used in the previous test.
11. Connect the 5-turn DC current loop to the calibrator.
12. Set the calibrator to AC Amps.
13. Degauss the probe, and then connect it to the 5-turn current loop.
14. Set the probe range to 5 A.
15. Set the oscilloscope:
 - Vertical sensitivity to 500 mA/div
 - Trigger at 50%
 - Acquisition mode to average 16
 - Coupling to DC
 - Automeasurement to display AMPLITUDE

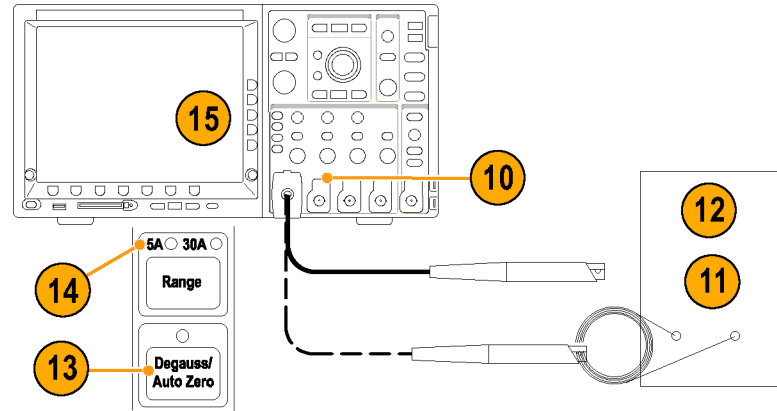

16. Set the calibrator to output a 500 Hz square wave into the 5-turn current loop.
17. Set the calibrator to the first value in the Test Record, and enable the output.
18. Measure the waveform amplitude (c).

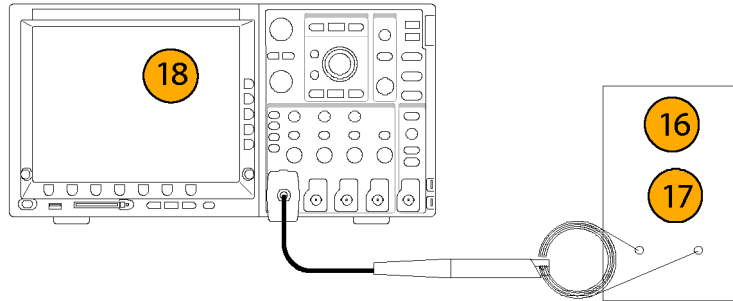

19. Use the measured waveform amplitude (c) from step 18 and the oscilloscope DC gain accuracy value (b) from step 7 to calculate the probe DC gain accuracy (d).
20. Record the calculated probe DC gain accuracy value (d) in the test record.
21. Set the probe range to 30 A.
22. Set the oscilloscope to 5 A/div.
23. Measure the waveform amplitude (e).

19

5 A Range:

$$d = \left\{ \frac{[c \text{ App} - 3.0 \text{ App}]}{3.0 \text{ App}} \times 100 \right\} - b$$

Example:

$$\left\{ \frac{3.01 \text{ App} - 3.0 \text{ App}}{3.0 \text{ App}} \times 100 \right\} - (-0.67\%) = +1\%$$

24. Use the measured waveform amplitude (e) from step 23 and the oscilloscope DC gain accuracy value (b) from step 7 to calculate the probe DC gain accuracy (f).
25. Record the calculated probe DC gain accuracy value (f) in the test record.

24

30 A Range:

$$f = \left\{ \frac{[e A_{PP} - 30.0 A_{PP}]}{30.0 A_{PP}} \times 100 \right\} - b$$

Rise Time and Bandwidth

This procedure verifies that the probe meets the rise time specification on both of the current ranges. The bandwidth of the probe is then calculated using the measured probe rise time.

1. Connect the BNC cable to the output of the pulse generator.
2. Connect the other end of the BNC cable to the HF current loop.
3. Set the pulse generator output and pulse width to maximum.
4. Set the oscilloscope:
 - Vertical sensitivity to 200 mA/div
 - Horizontal to 2 ns/div
 - Trigger at 50%
 - Averaging on (32)
 - Coupling to DC
 - Automeasurement to Rise Time
5. Set the probe range to the 5 A setting.
6. Degauss the probe.

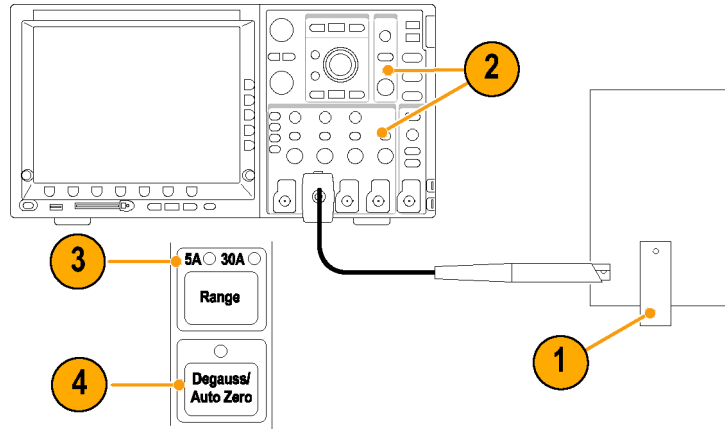

7. Clamp the current probe around the HF current loop. Verify that the arrow-shaped indicator on the probe points away from the pulse generator.
8. Record the rise time measurement in the Test Record.
9. Calculate the probe bandwidth using the measured rise time in the following formula:

$$BW = \frac{0.35}{t_r}$$

10. Record the calculated bandwidth value in the test record.

Test Record

Probe Model/Serial Number:

Certificate Number:

Temperature:

RH %:

Date of Calibration:

Technician:

Performance test	Range	Test Current	Calibrator squarewave output	Expected output	Minimum	Incoming	Outgoing	Maximum
DC Gain Accuracy	5 A	± 1.5 A	0.3 A _{pk}	3 A _{p-p}	-3%			+3%
	30 A	± 15 A	3.0 A _{pk}	30 A _{p-p}	-3%			+3%
Rise time	5 A	~ 1 A	< 500 ps	<2.92 ns	NA			2.92 ns
Bandwidth	5 A	NA	NA	>120 MHz	120 MHz			NA

Adjustments

The procedures that follow describe adjustments to the probe to bring the performance within the warranted specifications.

- DC gain accuracy

Equipment Required

Refer to the *Performance Verification* procedure for the equipment required. You also need an insulated, flat-bladed adjustment tool.

Equipment Setup

Refer to the *Performance Verification* procedure for the equipment setup.



CAUTION. To avoid ESD damage to the probe, use an antistatic wrist strap and work at a static-approved workstation when handling the probe

DC Gain Accuracy

This procedure describes the DC gain accuracy adjustments for the probe at the 5 A and 30 A range settings.

Adjust the 5 A Range

1. Complete steps 1 through 18 of the *DC Gain Accuracy Test* in the *Performance Verification* procedure. (See page 54, *DC Gain Accuracy*.)
2. Calculate the waveform target value (g) using the calculated oscilloscope gain accuracy value (b) from step 7 of the performance test, and the formula shown.
3. Adjust the 5 A DC gain control in the probe compensation box to the calculated target value from step 2, $\pm 0.02A$.

2

$$g = (3.0 App) \times [1 + b(\%)]$$

3

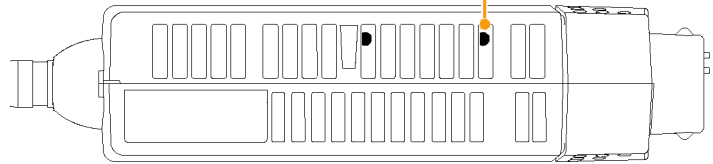

Adjust the 30 A Range

4. Set the probe range to 30 A.
5. Set the calibrator output to 3.0 A.
6. Set the oscilloscope to 5 A/div.
7. Measure the output amplitude.
8. Calculate the waveform target value (h) using the calculated oscilloscope gain accuracy value (b) from step 7 of the performance test, and the formula shown.
9. Adjust the 30 A DC gain control in the probe compensation box to the calculated target value from step 8, $\pm 0.2A$.
10. Disconnect the probe from the current source.

8

$$h = (30.0 A_{pp}) \times [1 + b (\%)]$$

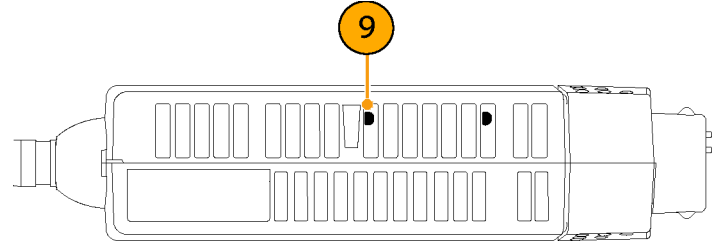

9

Maintenance

This section contains maintenance information for your probe.

Troubleshooting

The TCP0030 current probe is designed to work with all TekVPI-interface oscilloscopes and adapters. The LEDs on the probe alert you to error or status conditions affecting the probe. If the probe LEDs do not light as expected, or if some of the probe features do not work properly, an error condition may exist. See the following table.

Table 7: Probe troubleshooting

Symptom	Possible cause
LEDs on the probe do not light.	The oscilloscope channel may be bad: <ul style="list-style-type: none">■ Try another channel or another oscilloscope. If the probe still does not work, the probe is defective, and must be returned to Tektronix for repair.
An error message displays on the oscilloscope.	The message will describe the cause and solution. For example, if the Degauss Needed message appears, perform the degauss procedure.

Cleaning

Protect the probe from adverse weather conditions. The probe is not waterproof.



CAUTION. *To prevent damage to the probe, do not expose it to sprays, liquids, or solvents. Avoid getting moisture inside the probe during exterior cleaning.*

Do not use chemical cleaning agents; they may damage the probe. Avoid using chemicals that contain benzine, benzene, toluene, xylene, acetone, or similar solvents.

Clean the exterior surfaces of the probe with a dry, lint-free cloth or a soft-bristle brush. If dirt remains, use a soft cloth or swab dampened with a 75% isopropyl alcohol solution and rinse with deionized water. A swab is useful for cleaning narrow spaces on the probe, use only enough solution to dampen the swab or cloth. Do not use abrasive compounds on any part of the probe.

Repairing the Probe

The subassemblies listed below can be replaced on the probe. The replacement procedures are on the following pages.

Replaceable component	Procedures to use
Transformer	Probe Head Disassembly, Transformer Replacement
Cable/Circuit Board Assembly	Probe Head Disassembly, Cable/Circuit Board Assembly Replacement, Compensation Box Replacement
Compensation Box	Compensation Box Replacement
Switch Panel	Compensation Box Replacement

Equipment Required

The following equipment is necessary to perform the repair procedures.

Tool	Description
Screwdriver	#2 Phillips
Soldering iron	25 W
Cleaner	Isopropyl alcohol
Lubricant	Silicone-based grease
Compensation box separator ¹	Order Tektronix part number 003-1892-00 (See page 24, <i>Compensation Box Tool</i> .)

¹ Required for cable, switch panel, and compensation box replacement procedures

Probe Head Disassembly

Disassemble the probe head as follows:

1. Remove the two screws from the bottom of the probe.
2. Pull the strain relief boot back.

NOTE. The probe slide contains a tiny metal ball. In step 3, be careful not to lose the ball by accidentally letting it fall out.

3. Move the probe slide assembly to the open position. (See note above).

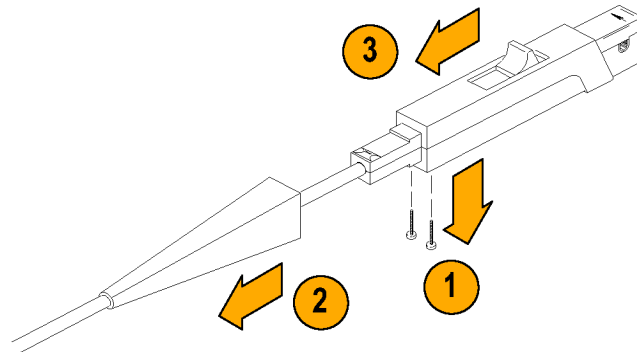

4. Hold the bottom half of the probe with one hand.
5. With your other hand, pivot the rear top half of the probe body up.
6. Slide the top half forward and off of the bottom half of the probe body.
7. Remove the metal ball.

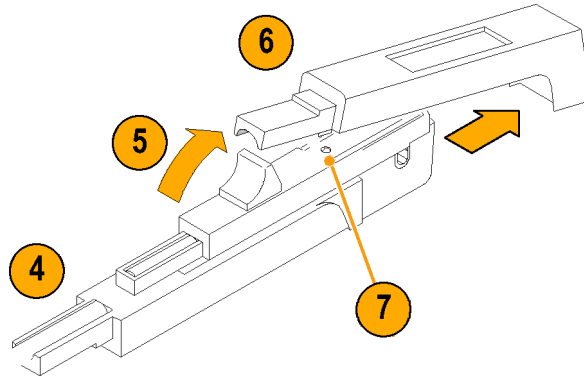

8. Turn the probe upside down, push the slide back slightly, and remove the slide.

You now have access to the transformer and cable/circuit board assembly. Use the following procedures to replace these components.

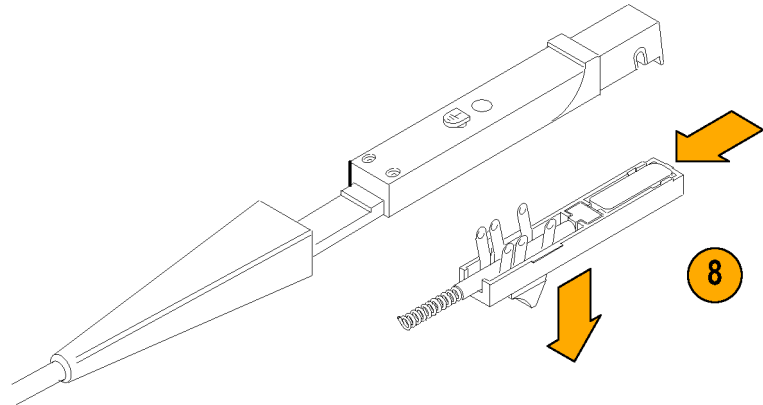

Replacement

Transformer

To replace the transformer, do the following:

1. Gently lift the front edge of the circuit board and transformer enough to clear the probe body.
2. Pull the transformer socket straight off the circuit board pins.
3. Align the socket of the new transformer to the circuit board pins and connect them.
4. Seat the components back in the probe.

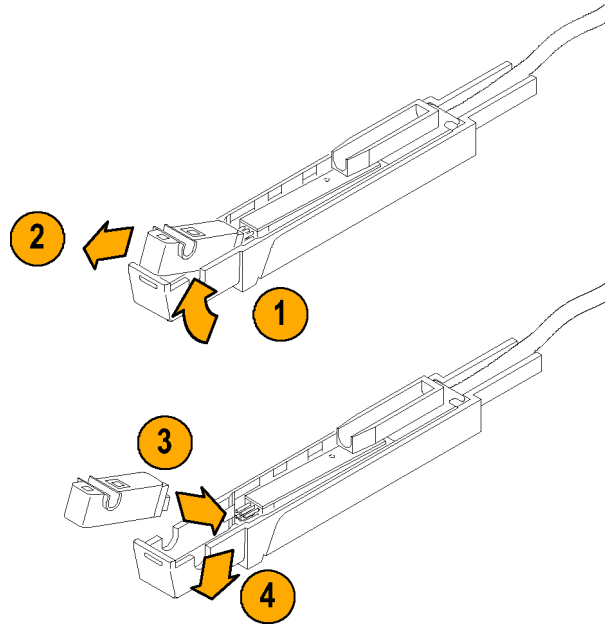

Cable/Circuit Board Assembly

To replace the cable/circuit board assembly, do the following:

1. Remove the transformer as described in the previous procedure. (See page 72, *Transformer*.)
2. Lift the plastic cable housing from the probe body half.
3. Unsolder the probe body connection on the circuit board. Be careful not to damage the circuit board.
4. Lift the circuit board/cable assembly from the probe body half.
5. Proceed to the *Compensation Box* procedure to detach the cable from the compensation box. (See page 74.)
6. To reassemble the probe after replacing the cable, do steps 1 through 5 of this procedure in reverse. (See following Caution statement.)

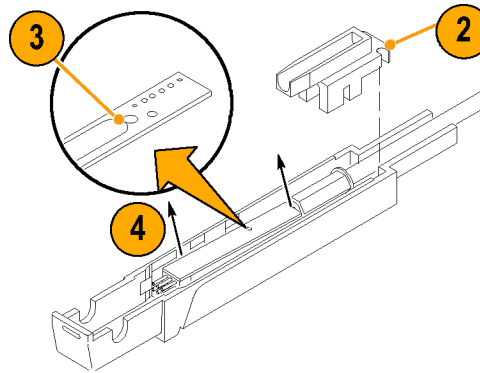



CAUTION. To avoid damaging the wires inside the probe, carefully dress the wires in the lower body half to avoid contact with the slide assembly. Exercise care when fitting the slide back into the probe body; aligning the switch contacts requires precision.

Compensation Box

1. Insert the separator tool into the four holes to disengage the front and back compensation box sections from each other.
2. Grasp the tool and front section together with one hand. Hold the back section with the other hand and gently pull the two sections apart.
3. Pull the cable grommet away from the back section of the compensation box.

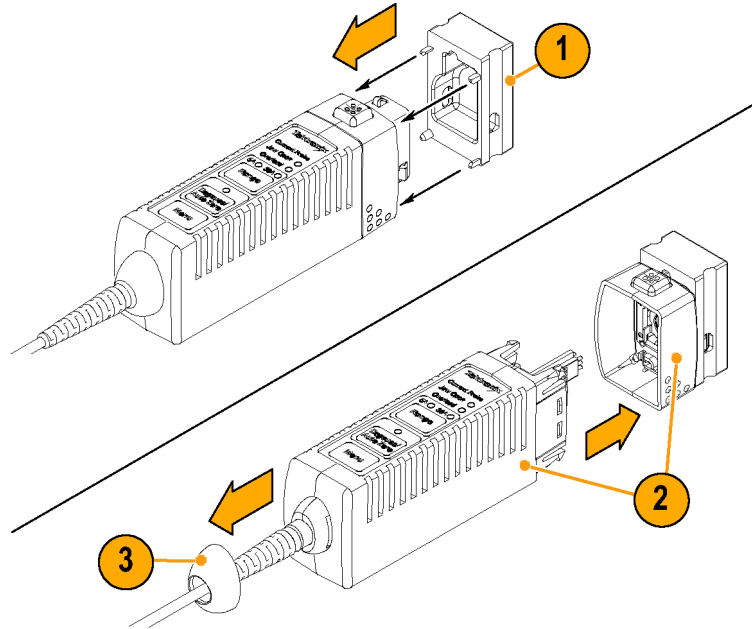

4. Separate the two halves of the compensation box enclosure.
5. Remove the metal shield from the main assembly.
6. If you are only replacing the switch panel, disconnect the panel, replace it, and reassemble the compensation box.
7. If you are replacing the cable or compensation box, disconnect the cable connector.
8. Install the new cable or compensation box by performing this procedure in reverse. If you are replacing the cable, refer also to the *Cable/Circuit Board Assembly* procedure to complete the cable replacement.

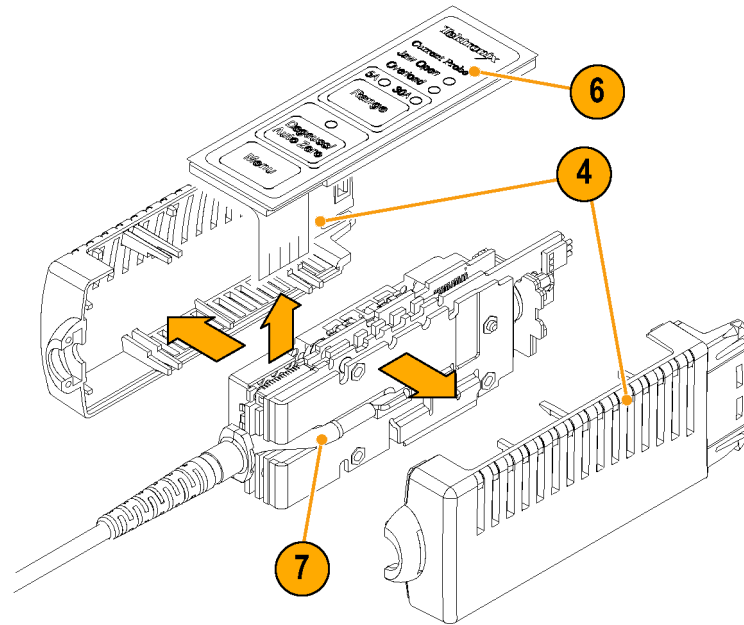

Reassembly

1. Before reassembling the probe body, be sure to check:
 - a. That the gap between the stationary and moveable core pieces is clean. If necessary, use isopropyl alcohol or a similar cleaning agent to clean the pieces.
 - b. That the contacts of the slide switch are clean, and if not, clean them.
 - c. If the plastic slide assembly requires lubrication. If so, apply silicone-based grease sparingly to the parts.
2. Reassemble the probe body by following steps 1 through 8 of the probe head disassembly procedure in reverse. (See page 69, *Probe Head Disassembly*.)

NOTE. *Exercise care when fitting the slide back into the probe body; aligning the switch contacts requires precision.*

If the slider does not work smoothly after tightening the two screws, loosen the screws slightly.

Replaceable Parts

This section contains a list of the replaceable parts for the probe. Use this list to identify and order replacement parts.

Parts Ordering Information

Replacement parts are available through your local Tektronix field office or representative.

Changes to Tektronix instruments are sometimes made to accommodate improved components as they become available and to give you the benefit of the latest circuit improvements. Therefore, when ordering parts, it is important to include the following information in your order:

- Part number
- Instrument type or model number
- Instrument serial number
- Instrument modification number, if applicable

Using the Replaceable Parts List

This section contains a list of the mechanical and/or electrical components that are replaceable for the probe. Use this list to identify and order replacement parts. Table 8 describes each column in the parts list.

Table 8: Parts List Column Descriptions

Column	Column name	Description
1	Figure & Index Number	Items in this section are referenced by figure and index numbers to the exploded view illustrations that follow.
2	Tektronix Part Number	Use this part number when ordering replacement parts from Tektronix.
3 and 4	Serial Number	Column three indicates the serial number at which the part was first effective. Column four indicates the serial number at which the part was discontinued. No entries indicates the part is good for all serial numbers.
5	Qty	This indicates the quantity of parts used.
6	Name & Description	An item name is separated from the description by a colon (:). Because of space limitations, an item name may sometimes appear as incomplete. Use the U.S. Federal Catalog handbook H6-1 for further item name identification.
7	Mfr. Code	This indicates the code of the actual manufacturer of the part.
8	Mfr. Part Number	This indicates the actual manufacturer or vendor part number.

Abbreviations

Abbreviations conform to American National Standard ANSI Y1.1-1972.

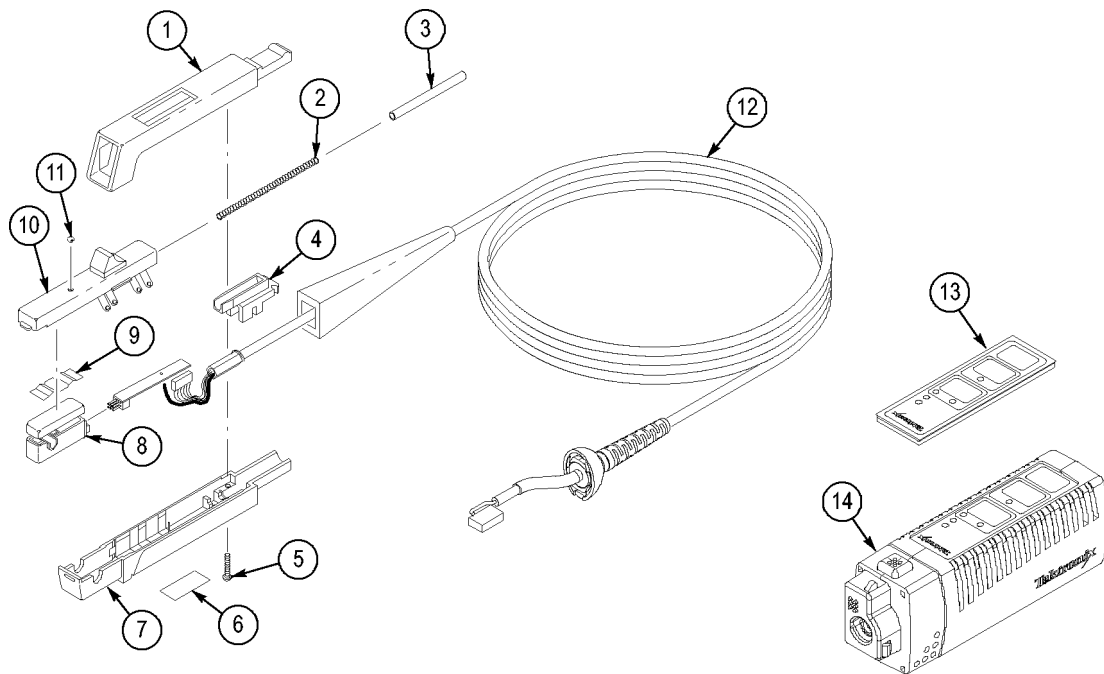

Figure 4: Replaceable Parts

Table 9: Replaceable Parts

Fig. & Index Number	Tektronix Part Number	Qty	Name & Description	Mfr. Code	Mfr. Part Number
4-1	204-0288-03	1	BODY HALF,PROBE:UPPER	80009	204-0288-03
-2	214-0835-00	1	SPRING,HLCPS:0.127 OD X 2.65 L,SST	91260	ORDER BY DESCRIPTION
-3	214-0849-00	1	RTNR RETURN SPR:BRS CD PL	80009	214-0849-00
-4	352-0106-00	1	HOLDER,SPR RTNR:DELRIN	TK2565	352-0106-00
-5	213-0087-00	2	SCREW,TPG,TC:2-32 X 0.5,TYPE BT,PANHEAD,STEEL,CADMIUM PLATED,POZIDRIVE	3M099	ORDER BY DESCRIPTION
-6	335-1357-00	1	MARKER, ID:PROBE ID	0KB05	335-1357-00
-7	204-0714-06	1	BODY,HALF:LOWER BODY HALF W/CONTACTS	80009	204-0714-06
-8	120-2081-00	1	XFMR SUBASSY:UPPER & LOWER TRANSFORMER	80009	120-2081-00
-9	214-0854-00	1	CONTACT,ELEC:UPPER SHELF,CU BE	TK1947	214-0854-00
-10	351-0121-04	1	CONT ASSY,ELEC:PROBE SLIDE ASSY	80009	351-0121-04

Table 9: Replaceable Parts (cont.)

Fig. & Index Number	Tektronix Part Number	Qty	Name & Description	Mfr. Code	Mfr. Part Number
-11	214-0997-00	1	BALL, BEARING: 0.094, SST	05469	ORDER BY DESCRIPTION
-12	174-5327-00	1	BD/CABLE ASSY: CABLE W/PROBE CIRCUIT BOARD	80009	174-5327-00
-13	260-2810-00	1	MEMBRANE SWITCH/CIRCUIT BOARD ASSY	80009	260-2810-00
-14	206-0564-00	1	COMPENSATION BOX ASSY	00009	206-0564-00

Table 10: Part Manufacturers

Mfr. Code	Manufacturer	Address	City, State, Zip Code
05469	BEARINGS INC	3634 EUCLID PO BOX 6925	CLEVELAND, OH 44101
0KB05	NORTH STAR NAMEPLATE INC	5750 NE MOORE COURT	HILLSBORO, OR 97124-6474
18359	PYLON CO. INC.	51 NEWCOMB ST	ATTLEBORO, MA 02703-1403
3M099	PORTLAND SCREW COMPANY	6520 N BASIN AVE	PORTLAND, OR 97217

Table 10: Part Manufacturers (cont.)

Mfr. Code	Manufacturer	Address	City, State, Zip Code
80009	TEKTRONIX INC	14150 SW KARL BRAUN DR PO BOX 500	BEAVERTON, OR 97077-0001
91260	CONNOR FORMED METAL PRODUCTS	1729 JUNCTION AVENUE	SAN JOSE, CA 95112
TK1947	NORTHWEST ETCH TECHNOLOGY	2601 S HOOD ST PO BOX 110610	TACOMA, WA 98411-0610
TK2548	XEROX CORPORATION	DIV OF XEROX CORPORATION 7431 EVERGREEN PARKWAY	HILLSBORO, OR 97124
TK2565	VISION PLASTICS INC	26000 SW PARKWAY CENTER DRIVE	WILSONVILLE, OR 97070

Index

A

- AC coupling, 34
- Accessories
 - optional, 22
 - standard, 19
- Adjustments, 63
- Amp-second product, 36

B

- Bucking current, 30

C

- Cleaning, 67
- Common mode noise, 33
- Connect the probe, 2
- Coupling modes, 34
- Current limitations
 - amp-second product, 36
 - maximum continuous, 35
 - maximum pulsed, 35
- Current loop, 52

D

- Damage
 - ESD, 2
- DC coupling, 34
- DC Gain Accuracy
 - Adjustment, 64
- DC LEVEL control, 34
- Degaussing, 3
 - while connected to a conductor, 26
- Differential current, 27
- Documentation, x

E

- Equipment required
 - performance verification, 51
- Equipment setup, 53
- ESD damage, 2
- Extending the current range of the probes, 29

F

- Features, 1

- Frequency derating, 35

G

- Gain accuracy check, 54

I

- Increasing bucking current, 30
- Increasing probe sensitivity, 32
- Indicators, 5

J

- Jaw damage, 10

L

- LEDs, flashing, 66

M

- Magnetic field errors, 33
- Maintenance, 66
- Maximum allowable pulse amplitude, 38

Maximum allowable pulse width, 37
Maximum continuous current
 rating, 35
Maximum pulsed current rating, 35
Measuring current
 current nulls, 27
 differential current, 27

N

Null current, 27

O

Options, 25

P

Performance verification, 50

Probe
 disassembly, 69
 reassembly, 76
 repairing, 68

Probe controls and indicators, 5

Probes

 coupling, 34
 extending the current range, 29
 increasing the current limit, 29
 maximum current limits, 35
 saturation, 35

R

Record, test, 62

Related documentation, x

Replaceable parts, 77

Replacing

 cable/circuit board assy, 72
 compensation box, 74
 transformer, 72

Rise time check, 59

S

Safety Summary, v

Service options, 25

Specifications, 39

 nominal, 47

 typical, 41

 warranted, 40

T

TekVPI, 2

Test record, 62

Troubleshooting, 66