

067-1686-00
Power Measurement Deskew
& Calibration Fixture

Instructions



071-1872-02

Overview

This fixture converts the oscilloscope PROBE COMPENSATION output (Probe Calibration on DPO7000 Series) or the TEK-DPG pulse generator output into a set of test point connections. These connections provide you with a convenient way to compensate for timing differences between voltage and current probes.

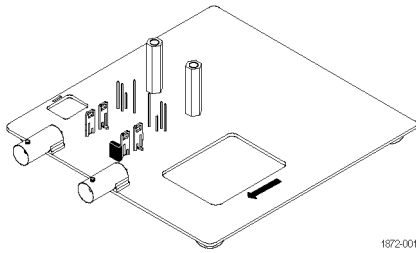

1872-001

You can also optimize the instrument gain and offset accuracy at the probe tips for both voltage and current probes. Use the table as a guide to connect a variety of Tektronix voltage and current probes together on the fixture.

Connecting to the Instrument

The fixture has two BNC inputs, Port A and Port B. The jaw size of the current probes and the operation that you want to perform determine which input to use (see table). Use the included

BNC cable to connect the fixture input to the Probe Calibration output of your DPO7000 instrument or to an external generator. Other TekVPI oscilloscope models, including the DPO3000 and DPO/MSO4000 series, require the TEK-DPG pulse generator for a signal source.

CAUTION. The maximum allowable voltage applied to either input is 8 V RMS. Voltages in excess of 8 V RMS can damage the fixture.

Table 1: Fixture Input Guide

Probe ¹	Operation	Input
Passive voltage probes:	Low frequency compensation	B
P6139A P5050 & other 10X passive probes	Gain and offset calibration ^{2,3}	B
	Compensate timing with respect to current probes	A/B ⁴
Active voltage probes:	Gain and offset calibration ³	B
TAP1500 TAP2500 TAP3500 TDP0500 TDP1000 TDP1500 P6243 P6245 P6246 P6247 P6248 P6250 P6251	Compensate timing with respect to current probes	A/B ⁴
High voltage probes:	Gain and offset calibration ³	B
P5200 P5205 P5210 ⁵ P6135A	Compensate timing with respect to current probes	A/B ⁴
Current probes:	Gain and offset calibration	A
TCP0030 TCP202 TCP312 TCP305	Compensate timing with respect to voltage probes	A
Current probes:	Gain and offset calibration	B
TCP303 TCP0150	Compensate timing with respect to voltage probes	B
Current probes:	Compensate timing with respect to voltage probes	A
A6302 A6312		
Current probes:	Compensate timing with respect to voltage probes	B
A6303		

- Not all probes are usable with all instruments.
- Gain and offset calibration is generally not needed for these probes.
- Remove jumper from fixture to perform this operation.
- Use Port A for small current probes, Port B for large.
- Requires external signal source.

Connecting Probes

The following diagrams show how to attach each type of probe tip to the fixture. Refer to the ground symbols on the fixture to establish the correct polarity.

WARNING. To avoid personal injury, use care while connecting probe tips to the square pins on the fixture. The ends of the square pins are sharp.

Active Voltage Probes (TAP1500, TAP2500, TAP3500, P6243, or P6245)

Connect the probe tip to the short pin and the probe ground to the long pin as shown.

Differential Probes (TDP0500, TDP1000, TDP1500, P6246, P6247, P6248, P6250, or P6251)

Connect the probe + input to the signal pin and the probe – input to the ground pin as shown. There is no connection to the probe ground input.

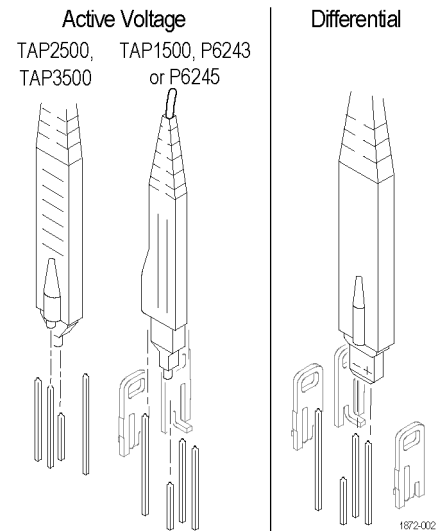

1872-002

Passive Voltage Probe (P6139A) or High Voltage Probes (P5200 Series)

Connect the probe tip and the ground lead to the two terminals as shown.

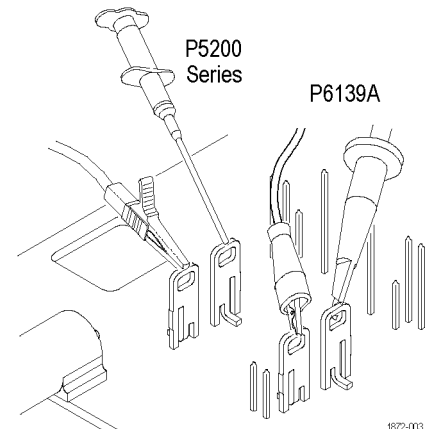

1872-003

Current Probes: TCP0030, TCP202, TCP312, TCP305, A6302, A6312 (small), & TCP0150, TCP303, A6303 (large)

Connect the current probe around the current loop as shown. Be sure to align the polarity arrows on the current probe and the fixture, and make sure the current probe slider is closed and locked.

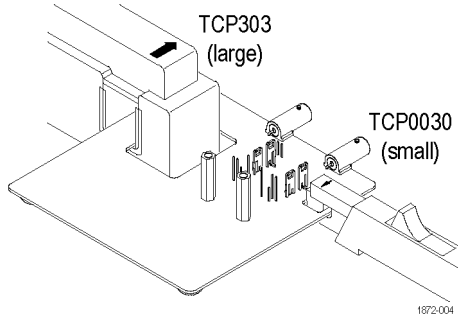

Using the Fixture

Perform the following steps to use the fixture. For best results, warm up the equipment for 20 minutes before performing these functions.

Optimize Gain and Offset Accuracy (Not all oscilloscopes support this function)

1. Connect the Port A or Port B side of the fixture to the instrument, depending on the probe type. (See the table in *Connecting to the Instrument*.)
2. If you are optimizing the gain and offset accuracy for a voltage probe on Port B, remember to remove the small jumper over the two pins on the fixture.

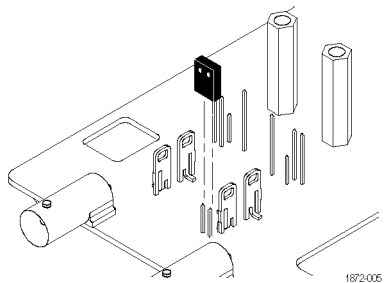

3. Connect the probe to the fixture as described in *Connecting Probes*.
4. Initiate the Calibrate Probe routine.
5. When the routine is finished, remove the connections and replace the small jumper across the two pins on the fixture. Leave the jumper installed for all other functions.

Compensate Probe Timing (Deskew)

1. Connect the Port A or Port B side of the fixture to the instrument, depending on the probe type. (See the table in *Connecting to the Instrument*.)
2. Connect the probes to the fixture.

3. Display all channels that you want to deskew.
4. Push the **AUTOSET** button on the instrument front panel.
5. Adjust vertical **SCALE** and **POSITION** for each channel so that the signals overlap and are centered on-screen (with active probes, adjusting offset may be required).
6. Adjust horizontal **POSITION** so that a triggered rising edge is at center screen.
7. Adjust horizontal **SCALE** so that the differences in the channel delays are clearly visible.
8. Adjust horizontal **POSITION** again so that the first rising edge is exactly at center screen. The fastest probe is connected to this channel. (The fastest probe is probably the one with the shortest cable or the highest bandwidth.)
9. Touch the **VERT** button or use the **Vertical** menu to display the vertical control window.
10. Touch the **Probe Deskew** button to display the channel-deskew control window.
11. Select one of the slower channels.

NOTE. If possible, perform the next step at a signal amplitude within the same attenuator range (vertical scale) as your planned signal measurements. Any change to the vertical scale after deskew is complete may introduce a new attenuation level (you can generally hear attenuator settings change) and therefore a slightly different signal path. This different path may cause up to a 200 ps variation in timing accuracy between channels.

12. Adjust the deskew time for that channel so that the signal aligns with that of the fastest channel.
13. Repeat steps 11 and 12 for each additional channel that you want to deskew.
14. Remove the connections.

Schematics

The schematic diagrams that follow show typical connections for both small- and large-style current probes.

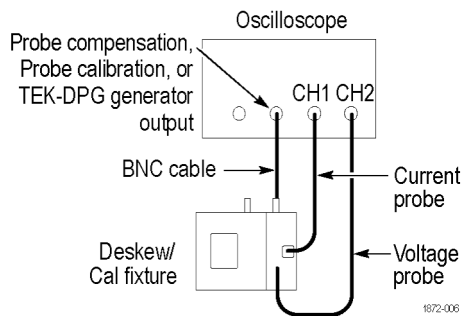

Figure 1: Typical small current probe connection

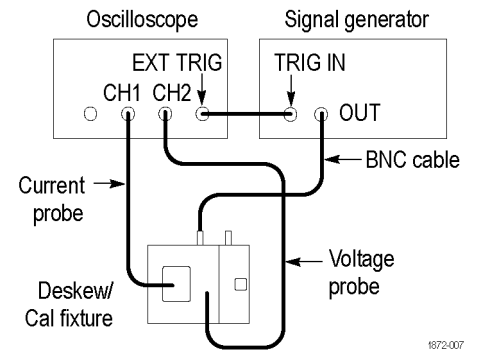

Figure 2: Typical large current probe connection using an external signal source

CAUTION. The maximum allowable voltage applied to either fixture input (Port A or Port B) is 8 V RMS. Voltages in excess of 8 V RMS may damage the fixture.

Safety Summary

To avoid potential hazards, use this product only as specified.

To avoid fire or personal injury, do not operate in wet/damp conditions.

Keep product surfaces clean and dry.

Safety terms in this manual

WARNING. These statements identify conditions or practices that could result in personal injury or loss of life.

Warranty Information

For warranty information, go to www.tektronix.com/service, and then use the provided links to search for your product's warranty.

Contacting Tektronix

Tektronix, Inc.
14200 SW Karl Braun Drive
PO Box 500 Beaverton, OR 97077
USA

For product information, sales, service, and technical support:

- In North America, call 1-800-833-9200.
- Worldwide, visit www.tektronix.com to find contacts in your area.