

# Instructions



**118-9477-01**

**118-9478-01**

**118-9487-01**

**Mictor Connector and Cable Replacement  
P6434 Mass Termination Probe**

**075-0480-00**

## **Warning**

The servicing instructions are for use by qualified personnel only. To avoid personal injury, do not perform any servicing unless you are qualified to do so. Refer to all safety summaries prior to performing service.

Copyright © Tektronix, Inc. All rights reserved.

Tektronix products are covered by U.S. and foreign patents, issued and pending. Information in this publication supercedes that in all previously published material. Specifications and price change privileges reserved.

Printed in the U.S.A.

Tektronix, Inc., P.O. Box 1000, Wilsonville, OR 97070-1000

TEKTRONIX and TEK are registered trademarks of Tektronix, Inc.

# Kit Description

This kit includes parts and instructions to service the P6434 Mass Termination Probe (see Figure 1). The specific parts included with this kit depend on which service kit you ordered. See page 2 for part lists of the electrical service kits available for the P6434 probe. Refer to your manual for mechanical service kit information.

---

**NOTE.** These service kits include upgraded components that require specific installation procedures that differ from those in the P6434 Instructions, part numbers 070-9793-00 and -01. If you have either of those versions, you must use these instructions for servicing your P6434 probe.

---

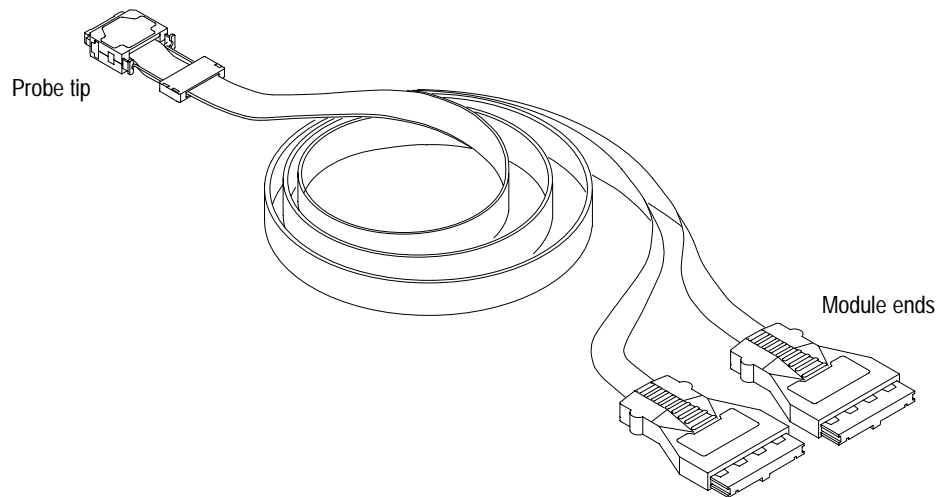

Figure 1: P6434 Mass Termination Probe

## Minimum Tool and Equipment List

Quantity	Description
1 ea	Tweezers
2 ea	Small, flat-bladed screwdriver
1 ea	0.050 inch hexagonal screwdriver

### Kit Parts List for 118-9477-01

Quantity	Part number	Description
2 ea	NS	ELASTOMER CONNECTOR
1 ea	NS	SPACER STRIP, PLASTIC
1 ea	NS	BOARD HOLDER, MOLDED
2 ea	NS	PULL GRIP HALVES
2 ea	NS	PULL GRIP CORD
1 ea	NS	PIN 1 SIDE CABLE WITH CIRCUIT BOARDS
1 ea	NS	INSTRUCTION, KIT: MICTOR CONNECTOR AND CABLE REPLACEMENT, P6434 PROBE

NS-Not Saleable

### Kit Parts List for 118-9487-01

Quantity	Part number	Description
2 ea	NS	ELASTOMER CONNECTOR
1 ea	NS	SPACER STRIP, PLASTIC
1 ea	NS	BOARD HOLDER, MOLDED
2 ea	NS	PULL GRIP HALVES
2 ea	NS	PULL GRIP CORD
1 ea	NS	PIN 38 SIDE CABLE WITH CIRCUIT BOARDS
1 ea	NS	INSTRUCTION, KIT: MICTOR CONNECTOR AND CABLE REPLACEMENT, P6434 PROBE

NS-Not Saleable

### Kit Parts List for 118-9478-01

Quantity	Part number	Description
2 ea	NS	ELASTOMER CONNECTOR
1 ea	NS	SPACER STRIP, PLASTIC
1 ea	NS	BOARD HOLDER, MOLDED
1 ea	NS	MICTOR CONNECTOR BD WITH MICTOR CONNECTOR
1 ea	NS	INSTRUCTION, KIT: MICTOR CONNECTOR AND CABLE REPLACEMENT, P6434 PROBE

NS-Not Saleable

# Installation Instructions

The following procedures instruct you to install any of the three service kits listed on page 2. If you are only installing the connector parts kit, follow the *Probe Tip* procedures on pages 3 and 6. If you are installing either of the cable parts kits, you must also perform the *Latch Release Grip* and *Module End* procedures.

## Disassembling the Probe

Refer to Figure 2 as a guide to disassembling the probe tip.

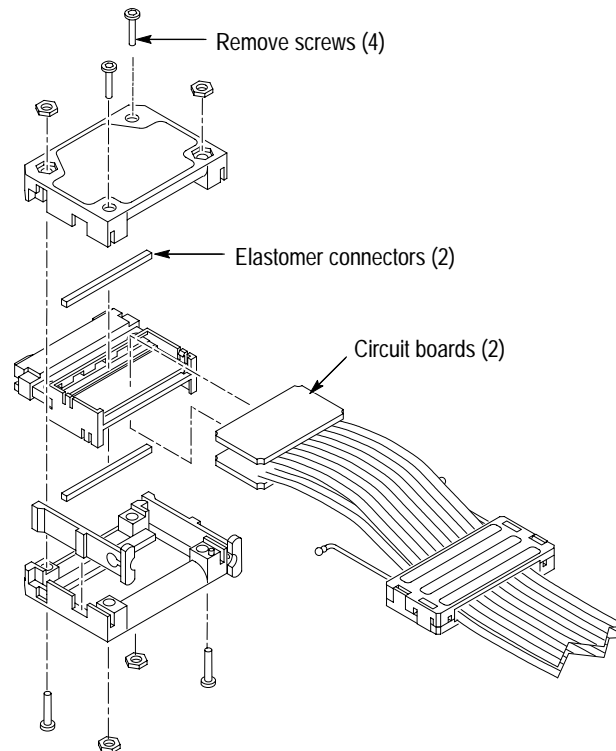

**Figure 2: Disassembling the P6434 probe**

**Probe Tip** To disassemble the probe tip, follow these steps:

1. Remove the four screws from the outside of the probe case using a .050 inch hexagonal screwdriver, and open the case halves.
2. Gently remove the two circuit boards and cables from the board holder. The circuit boards are held in place by two tab features in the board holder.

The circuit boards hold the elastomer connectors (which are very small) in place. When you remove the circuit boards, the elastomer connectors may fall out of the probe.



---

**CAUTION.** To prevent damage to the elastomer, use tweezers and handle the elastomer connectors on the flat areas adjacent to the gold plated contact pads. The elastomer connectors are very small and are susceptible to contamination by natural skin oils and mishandling.

---

3. Using tweezers on the flat areas adjacent to the gold plated contact pads, remove the elastomer connectors. See Figure 6 on page 7.
4. If you are replacing either the pin 1 or pin 38 cable, follow the *Latch Release Grip* and *Module End* disassembly procedures on pages 4 and 5.
5. If you are only installing the Mictor connector kit, follow the *Probe Tip* procedure on page 6.

### Latch Release Grip

To disassemble the latch release grip, follow these steps:

1. Use two small, flat-bladed screwdrivers in the slots opposite the tabs on each side of the grip as shown in Figure 3.
2. With thumbs placed lightly on the tabs to be released, pry the grip open by carefully levering the screwdrivers down. Do not overstress the tabs beyond deflection required to release the tabs.

When you open the latch release grip, the latch release cord comes out of the grip, thereby detaching the grip from the latch release on the probe.

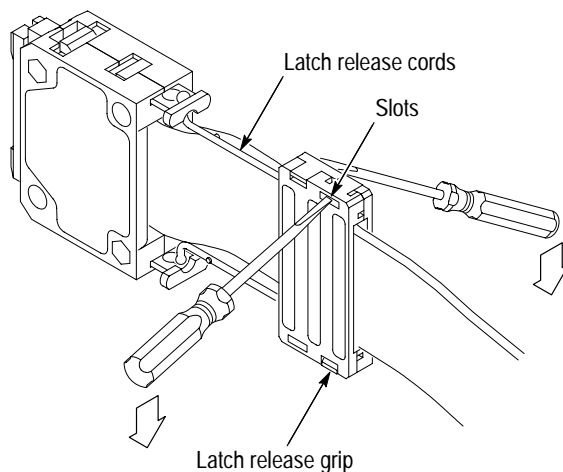

**Figure 3: Disassembling the latch release grip**

**Module End**

To disassemble the module end of the probe, refer to Figure 4 and follow these steps:

1. On the module end, remove the four screws from the outside of the connector housing using a .050 inch hexagonal screwdriver, and open the housing.
2. Remove the pin 1 and pin 38 cables with connectors attached.
3. Remove the trim pieces from the connector housing.

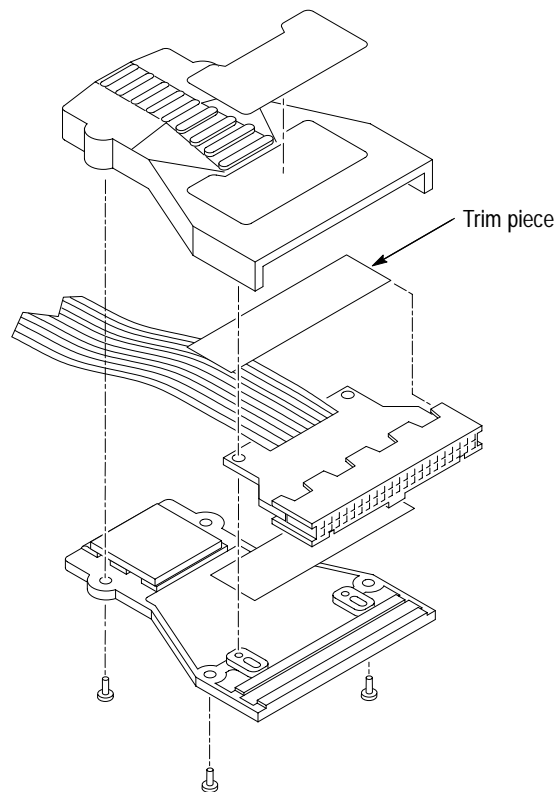

Figure 4: Disassembling the module end

## Reassembling the Probe

Use the following procedures to reassemble the P6434 probe.

---

**NOTE.** When reassembling the probe, you must use both the new board holder and both elastomer connectors included with the service kit. These components have design improvements that must be replaced as a set.

---

**Probe Tip** To reassemble the probe tip, refer to Figure 5 and follow these steps:

1. If you are reusing the Mictor connector circuit board, remove the old board holder.
2. Install the Mictor connector circuit board into the new board holder.

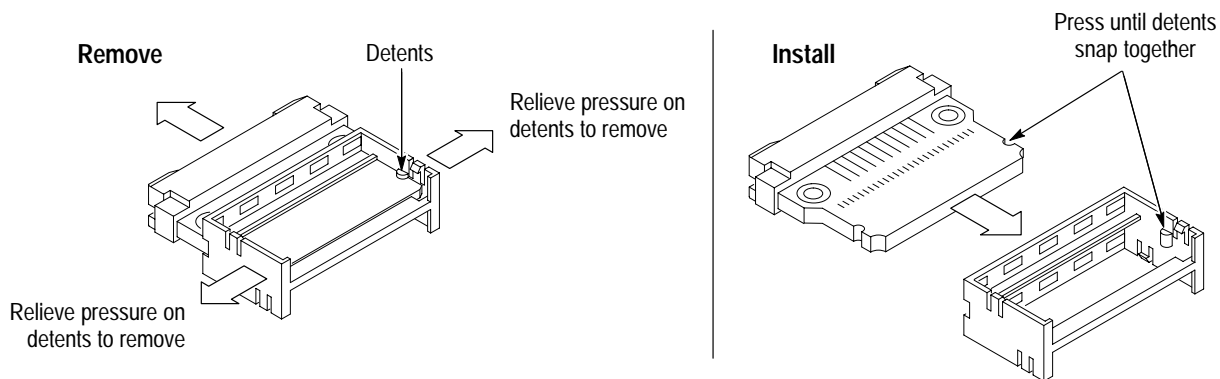

**Figure 5: Mictor connector circuit board and board holder**

3. Lay the Mictor board assembly on a flat surface with the pin 1 side of the connector facing up. See Figure 7 for the correct orientation.



---

**CAUTION.** To prevent damage to the elastomer, use tweezers and handle the elastomer connectors on the flat areas adjacent to the gold plated contact pads. The elastomer connectors are very small and are susceptible to contamination by natural skin oils and mishandling.

---

4. Using tweezers on the flat areas on both sides of the gold plated contact pads, carefully orient the elastomer and place it in the elastomer slot in the board holder, as shown in Figure 6.



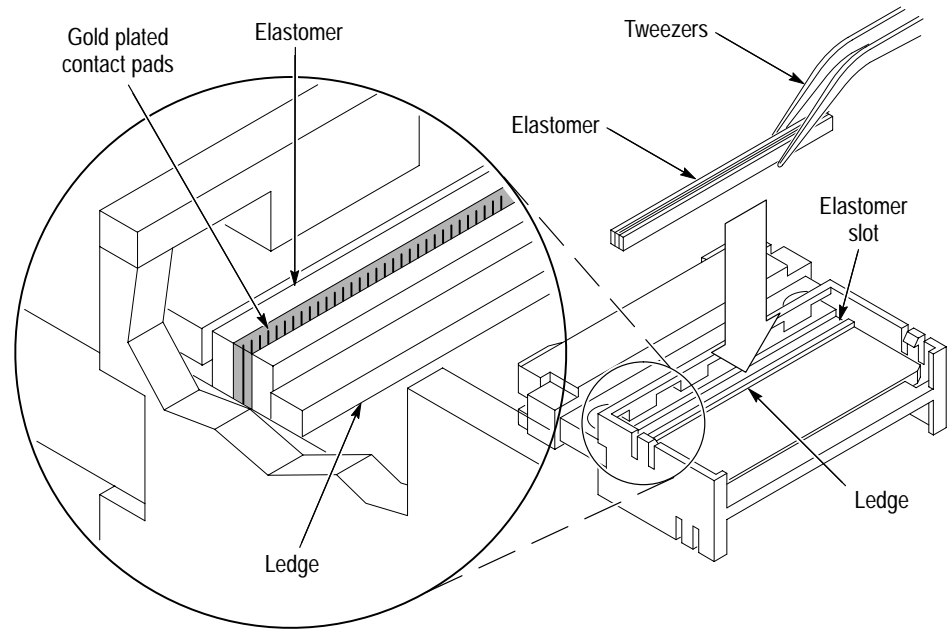

**Figure 6: Positioning the elastomer connector**

5. Place the circuit board attached to the pin 1 cable into the back (cable side) of the board holder as shown in Figure 7.
6. Press the front (connector side) of the circuit board attached to the cable down, until it snaps into place in the board holder.

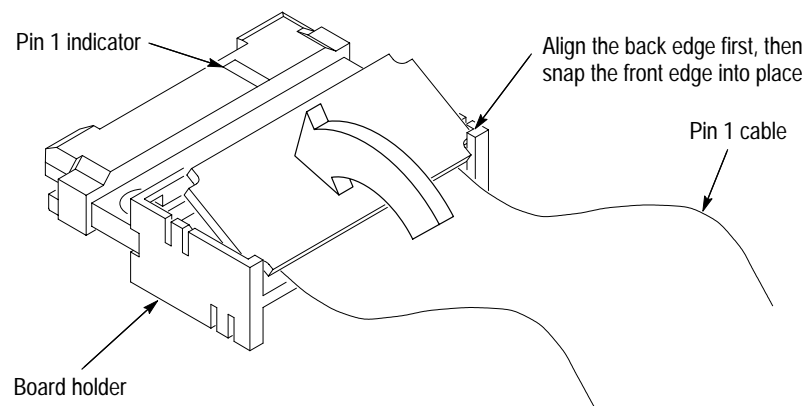

**Figure 7: Positioning the circuit board in the board holder**

7. Turn the probe over and repeat steps 3 through 6 for the pin 38 side of the probe.

8. Inspect the inside of the probe case halves before reassembling the probe:  
If the spacer strip material is black foam, perform steps a through c. The replacement plastic spacer strips improve cable reliability.

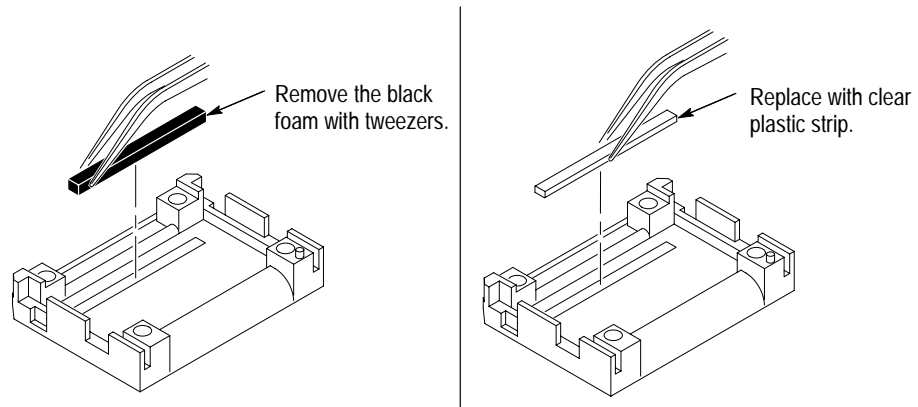

**Figure 8: Replacing the spacer strips in the probe case halves**

- a. If the spacer strip material is black foam, remove the black foam strips from both halves with tweezers. See Figure 8.
  - b. Remove the protective paper from the clear plastic spacer strips provided with the repair kit. (One side of the strips has an adhesive coating.)
  - c. Use tweezers to locate the plastic spacer strips to the probe case halves. Apply finger pressure to set the strips in place.
9. Position a latch release on each side of the case half. See Figure 9.

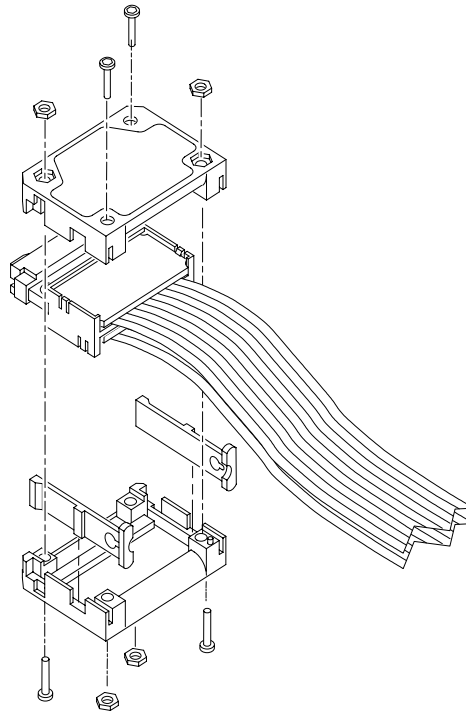

**Figure 9: Reattaching the latch releases and case halves**

- 10.** Align the pin 1 case half with the pin 1 side of the connector, attach the case halves, and reconnect the screws as shown in Figure 9.
- 11.** If you did not replace either cable assembly, the probe is now ready for testing. Follow the *Functional Verification* procedure in the *P6434 Instructions* manual, which came with your probe.

### Latch Release Grip

To reassemble the latch release grip, follow these steps:

- 1.** Place the latch release cords into the latch releases as shown in Figure 10.
- 2.** Push the latch release downward to force the latch release cord to snap through the slot and into the small hole.

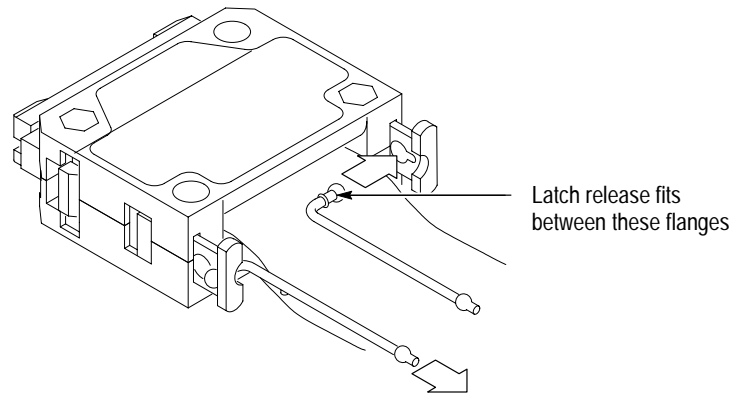

**Figure 10: Reattaching the latch release cords to the latch releases**

3. Place the other end of the latch release cords into the latch release grip and reconnect the latch release grip as shown in Figure 11.

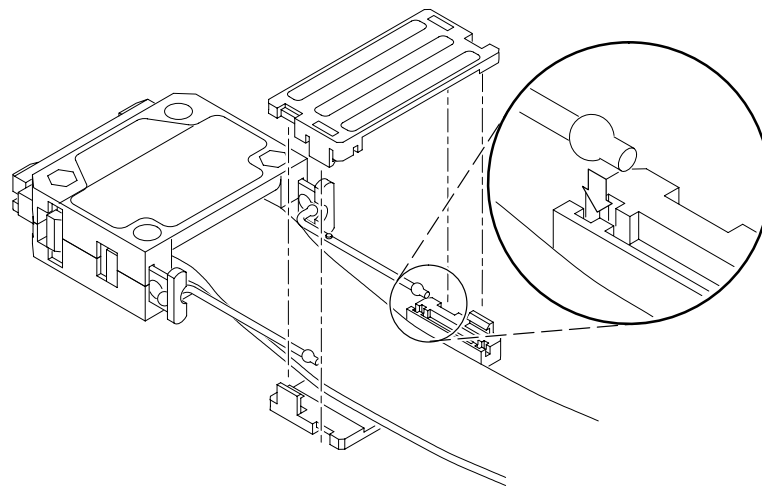

**Figure 11: Reconnecting the latch release cords to the latch release grip**

4. You may need to reapply labels. Refer to the description of *Labels* in the *P6434 Instructions* manual, which came with your probe.

**Module End**

To reassemble the module end of the probe, follow these steps:

1. If you are replacing either the pin 1 or pin 38 cable, follow the procedure to reassemble the probe tip.
2. On the module end, position the trim pieces in the connector housing as shown in Figure 12.

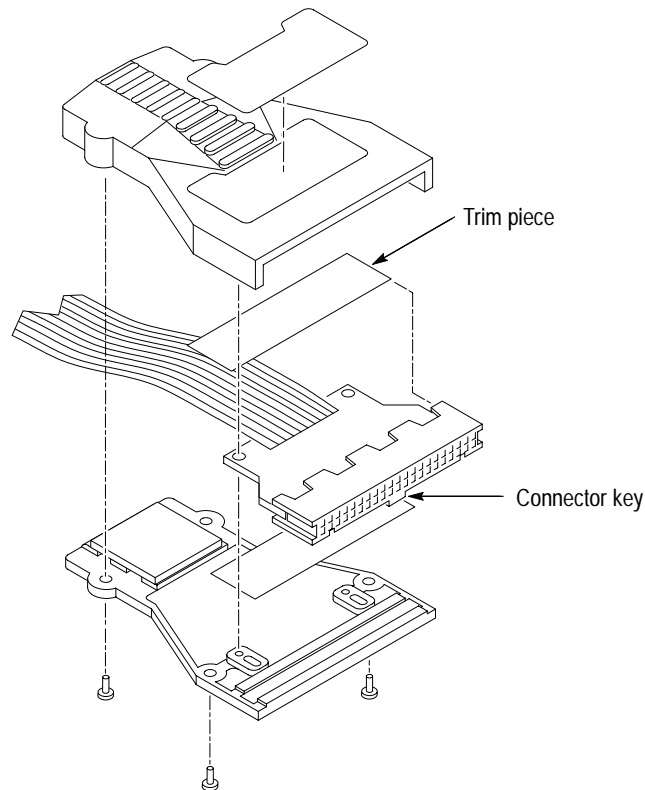

**Figure 12: Reassembling the module end**

3. Orient the non keyed side of the connector to the case half with the label, and position the connector in the case halves.
4. Attach the case halves and reconnect the screws as shown in Figure 12.
5. You may need to reapply labels. Refer to the description of *Labels* in the *P6434 Instructions* manual, which came with your probe, for information on how to apply labels.
6. Perform the *Functional Verification* in the *P6434 Instructions* manual, which came with your probe, to verify the basic functionality of the probe.

■ End of document ■