

Instructions



050-3571-03 and Above TLA714, TLA715, TLA720, and TLA721 CD-RW Drive Replacement Kit

075-0795-03

Warning

The servicing instructions are for use by qualified personnel only. To avoid personal injury, do not perform any servicing unless you are qualified to do so. Refer to all safety summaries prior to performing service.

www.tektronix.com



075079503

Copyright © Tektronix, Inc. All rights reserved. Licensed software products are owned by Tektronix or its subsidiaries or suppliers, and are protected by national copyright laws and international treaty provisions.

Tektronix products are covered by U.S. and foreign patents, issued and pending. Information in this publication supercedes that in all previously published material. Specifications and price change privileges reserved.

TEKTRONIX and TEK are registered trademarks of Tektronix, Inc.

Contacting Tektronix

Tektronix, Inc.
14200 SW Karl Braun Drive
P.O. Box 500
Beaverton, OR 97077
USA

For product information, sales, service, and technical support:

- In North America, call 1-800-833-9200.
- Worldwide, visit www.tektronix.com to find contacts in your area.

Service Safety Summary

Only qualified personnel should perform service procedures. Read this *Service Safety Summary* and the *General Safety Summary* in the product service manual or the instruction manual.

Do Not Service Alone. Do not perform internal service or adjustments of this product unless another person capable of rendering first aid and resuscitation is present.

Disconnect Power. To avoid electric shock, switch off the instrument power, then disconnect the power cord from the mains power.

Use Care When Servicing With Power On. Dangerous voltages or currents may exist in this product. Disconnect power, remove battery (if applicable), and disconnect test leads before removing protective panels, soldering, or replacing components.

To avoid electric shock, do not touch exposed connections.

Kit Description

This kit provides parts and instructions to replace the CD-RW drive for your TLA714, TLA715, TLA720, and TLA721 logic analyzer mainframes. This kit is not available for the TLA704 or TLA711 logic analyzer mainframes.

This document supports Tektronix modification: 564, 685, ECR 30450, and ECR 30766.

Products

TLA714 Portable Mainframe	All serial numbers
TLA715 Portable Mainframe	All serial numbers
TLA720 Benchtop Mainframe	All serial numbers
TLA721 Benchtop Mainframe	All serial numbers

Minimum Tool and Equipment List

Required tools and equipment	Part number or Description
Screwdriver handle	Accepts Torx®-driver bits
T-10 Torx tip	Used for removing most of the T-10 size screw heads on the TLA720 and TLA721 controllers
T-15 Torx tip	Used for removing most of the TLA714 or TLA715 instrument's screws. Torx®-driver bit for T-15 size screw heads
#1 Phillips screwdriver	Screwdriver for removing small Phillips screws
#0 Phillips screwdriver with 6-inch shaft	Screwdriver for removing small Phillips screws on the CD-ROM drive
Nut driver	A $\frac{3}{16}$ -inch nut driver used for removing controller front panel hardware
Nut driver	A $\frac{1}{4}$ -inch nut driver used for removing nuts on the back side of the controller front panel
Flat blade screwdriver	Small flat blade screwdriver for removing controller front panel hardware
Spudger tool for removing TLA714 or TLA715 Trim Ring	Tektronix part number: 003-0008-00

Kit Parts List

Quantity	Part number	Description
1 ea.	063-3666-xx	Software package, Click'N Burn software patch
1 ea.	065-0666-xx	Disk Drive; Optical; CD-W224E-A93 CD-RW and packaging
1 ea.	075-0795-03	Instructions, 050-3571-xx CD-RW Drive Replacement

Installation Instructions



WARNING. *These servicing instructions are for use by qualified personnel only. To avoid personal injury, do not perform any servicing unless you are qualified to do so. Refer to all safety summaries prior to performing service.*

These instructions assume that you are familiar with servicing the instrument. If you need further details for disassembling or reassembling the instrument, refer to one of the following service manuals:

- *TLA714 Portable Mainframe Service Manual (071-0267-xx)*
- *TLA715 Portable Mainframe Service Manual (071-0913-xx)*
- *TLA720 Benchtop Controller Service Manual (071-0269-xx)*
- *TLA721 Benchtop & TLA7XM Expansion Mainframe Service Manual (071-0912-xx)*

You may also contact your nearest Tektronix service center for installation assistance.



CAUTION. *To prevent static discharge damage, service the product only in a static-free environment. Observe standard handling precautions for static-sensitive devices while installing this kit. Always wear a grounded wrist strap, grounded foot strap, and static resistant apparel while installing this kit.*



WARNING. *To prevent serious injury or death, power off the instrument with the On/Standby switch, and disconnect the power cord from the AC power connector.*

Mainframe Specific Instructions

If you are installing the CD-RW drive in a TLA714 or TLA715 portable logic analyzer mainframe, follow the instructions under *TLA714 and TLA715 CD-RW Drive Instructions* beginning on page 6.

If you are installing the CD-RW drive in a TLA720 Benchtop Controller follow the instructions under *TLA720 CD-RW Drive Instructions* beginning on page 10.

If you are installing the CD-RW drive in a TLA721 Benchtop Controller follow the instructions under *TLA721 CD-RW Drive Instructions* beginning on page 18.

TLA714 and TLA715 CD-RW Drive Instructions

This section contains procedures for replacing the CD-RW drive in the TLA714 or TLA715 portable mainframe. The instructions for the TLA714 and TLA715 are similar and differences between the two products are called out as necessary.

These instructions require that you be familiar with servicing the instrument. If you are not familiar with servicing the instrument, you are strongly recommended to contact your nearest Tektronix service representative.

Remove the Replaceable Hard Disk Drive

Complete the following steps to remove the replaceable hard disk drive from the mainframe. Always remove the hard disk drive before accessing any of the replaceable components in the instrument.



CAUTION. Do not remove the replaceable hard disk drive while the instrument is powered on. You can permanently damage the replaceable hard disk drive if you remove it while the instrument is powered on. Always power down the mainframe before removing the replaceable hard disk drive.

1. Power down the instrument and disconnect the power cord.
2. Press the latch on the side of the instrument to unlatch the hard disk drive.
3. Remove the hard disk drive from the instrument by pulling on the handle.

Remove the Accessories Pouch

The accessories pouch is held in place on the top cover by snaps. Gently lift up on each corner of the pouch until the pouch snaps free from the top cover.

Remove the Trim Ring

1. Set the mainframe with the cord-wrap feet on the work surface and the bottom facing you.
2. Use the spudger tool to detach the three plastic snaps from the bottom cover (see Figure 1). Then, swing the bottom of the ring upward and work the rest of the ring off the front panel.

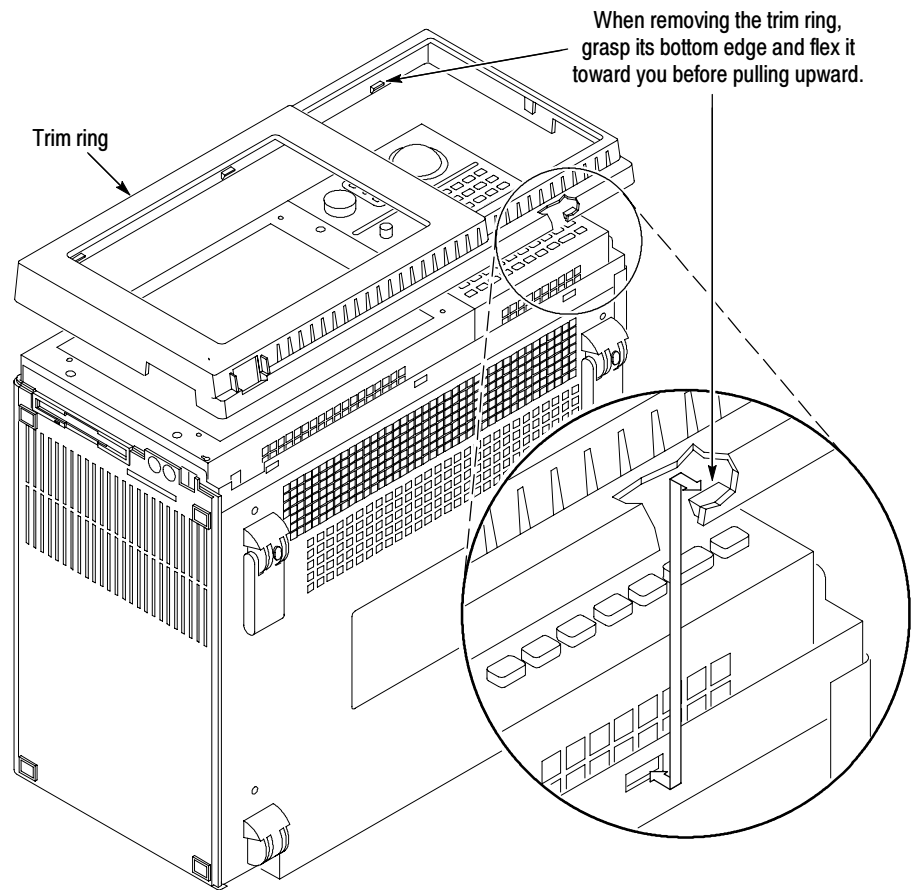

Figure 1: Trim ring removal

Remove the Flat Panel Display Assembly

1. Remove the five screws that attach the flat panel display assembly to the mainframe (See Figure 2).
2. Lift the bottom edge of the flat panel display assembly and rotate it upward and off the front face of the instrument.
3. Detach the ribbon cable connecting the flat panel display assembly to the front panel interface board.
4. Detach the five-pin display backlight power connector and then set the assembly aside.

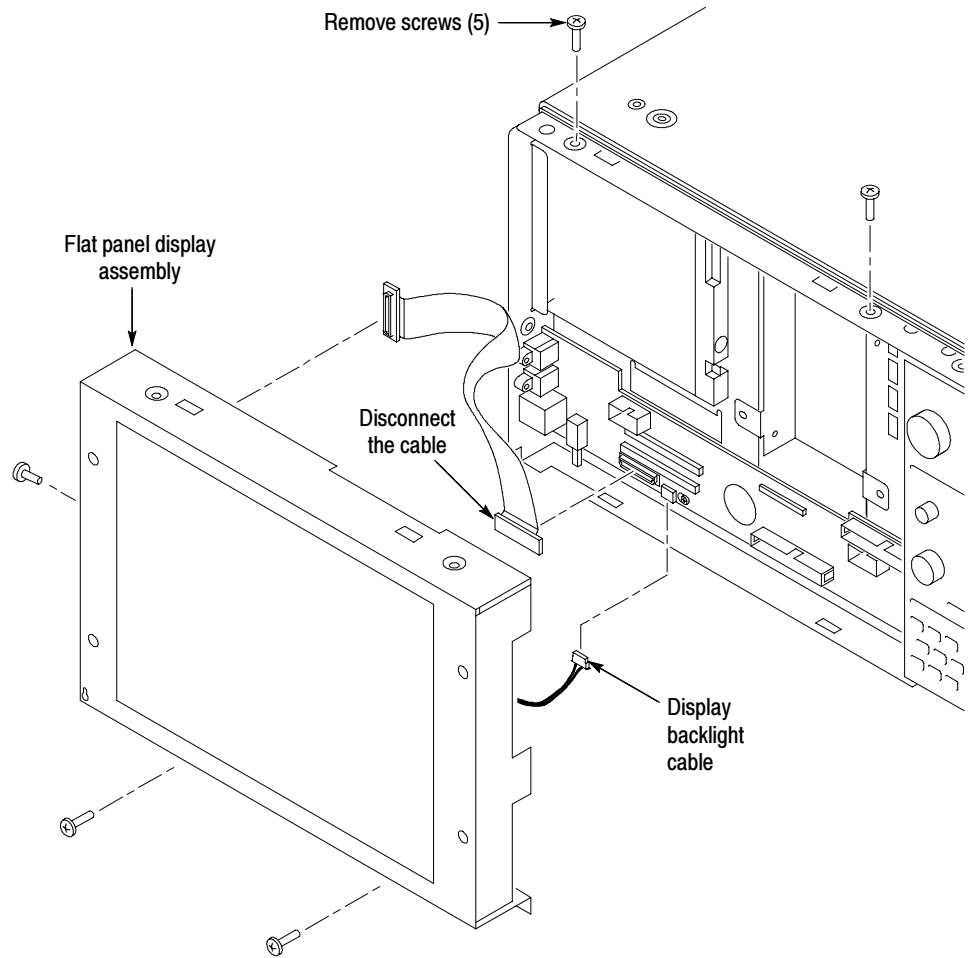

Figure 2: Flat panel display assembly removal

Remove the Front Panel Control Assembly

1. Disconnect the cable at J102 on the front panel interface board.
2. Remove the four screws that attach the front panel control assembly to the mainframe (See Figure 3).
3. Lift the bottom edge of the front control panel assembly and rotate it up and off the front face of the mainframe.
4. Detach the ribbon cable connecting the CD-RW drive to the interface board.

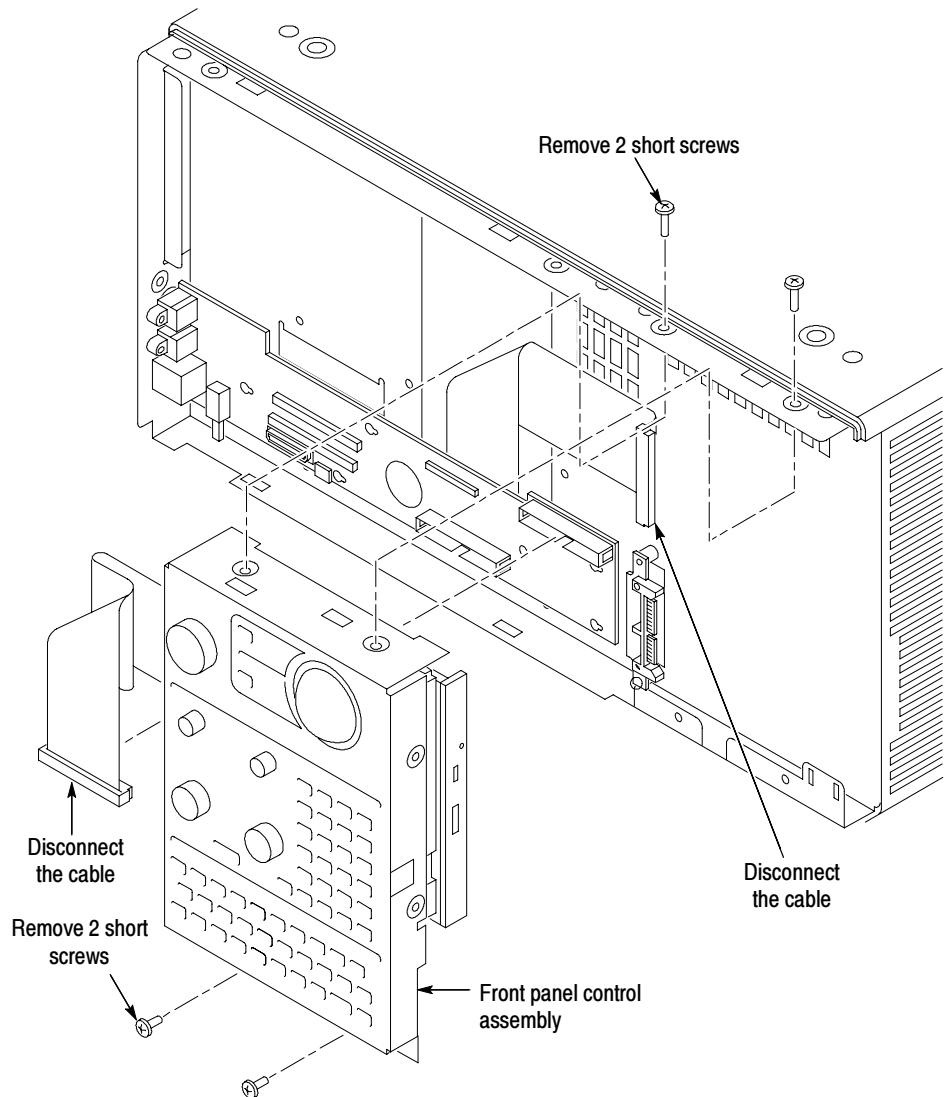

Figure 3: Front-panel control assembly removal

Replace the CD-RW Drive

The CD-RW drive is attached to the underside of the front panel control assembly.

1. Remove the four screws that attach the CD-RW drive to the front panel control assembly and then separate the CD-RW drive from the front panel assembly.
2. Remove the small Phillips screws that hold the CD-RW drive to the bracket and then slide the CD-RW drive out of the bracket.
3. Disconnect the interface board from the old CD-RW drive and attach it to the new drive.

4. Install the new CD-RW drive in the bracket.
5. Install the small Phillips screws that hold the CD-RW drive to the bracket and tighten the screws to 4 in-lbs.
6. Install the CD-RW drive assembly on the back of the front panel control assembly.
7. Install the four screws and tighten the screws to 8 in-lbs.

Reinstallation Complete the removal instructions in reverse order to reassemble the instrument.

Verify Operation Go to page 24 and follow the instructions to verify the operation and (if necessary) install the software.

TLA720 CD-RW Drive Instructions

This section contains procedures for replacing the CD-RW drive in the TLA720 Benchtop controller.

These instructions require that you be familiar with servicing the instrument because of the complexity of the Controller subassembly. If you are not familiar with servicing the instrument, you are strongly recommended to contact your nearest Tektronix service representative for installation information.



CAUTION. Do not remove the replaceable hard disk drive or any modules while the mainframe is powered on. You can permanently damage the mainframe if you remove the hard disk drive or modules while the mainframe is powered on.

Remove the Replaceable Hard Disk Drive

1. Power down the instrument and disconnect the power cord.
2. Press the latch on the side of the instrument to unlatch the hard disk drive.
3. Remove the hard disk drive from the instrument by pulling on the handle.

Remove the Benchtop Controller

1. If you have not already done so, power down the mainframe and disconnect the power cord.
2. Loosen the screws that secure the controller to the mainframe.
3. Disengage the benchtop controller from the mainframe using the injector/ejector handles.

4. Remove the controller from the mainframe and place it on a static-free work surface.

Remove the Benchtop Controller Covers

Remove the T-10 Torx-drive screws shown in Figure 4 and then remove the module and rear panel the covers.

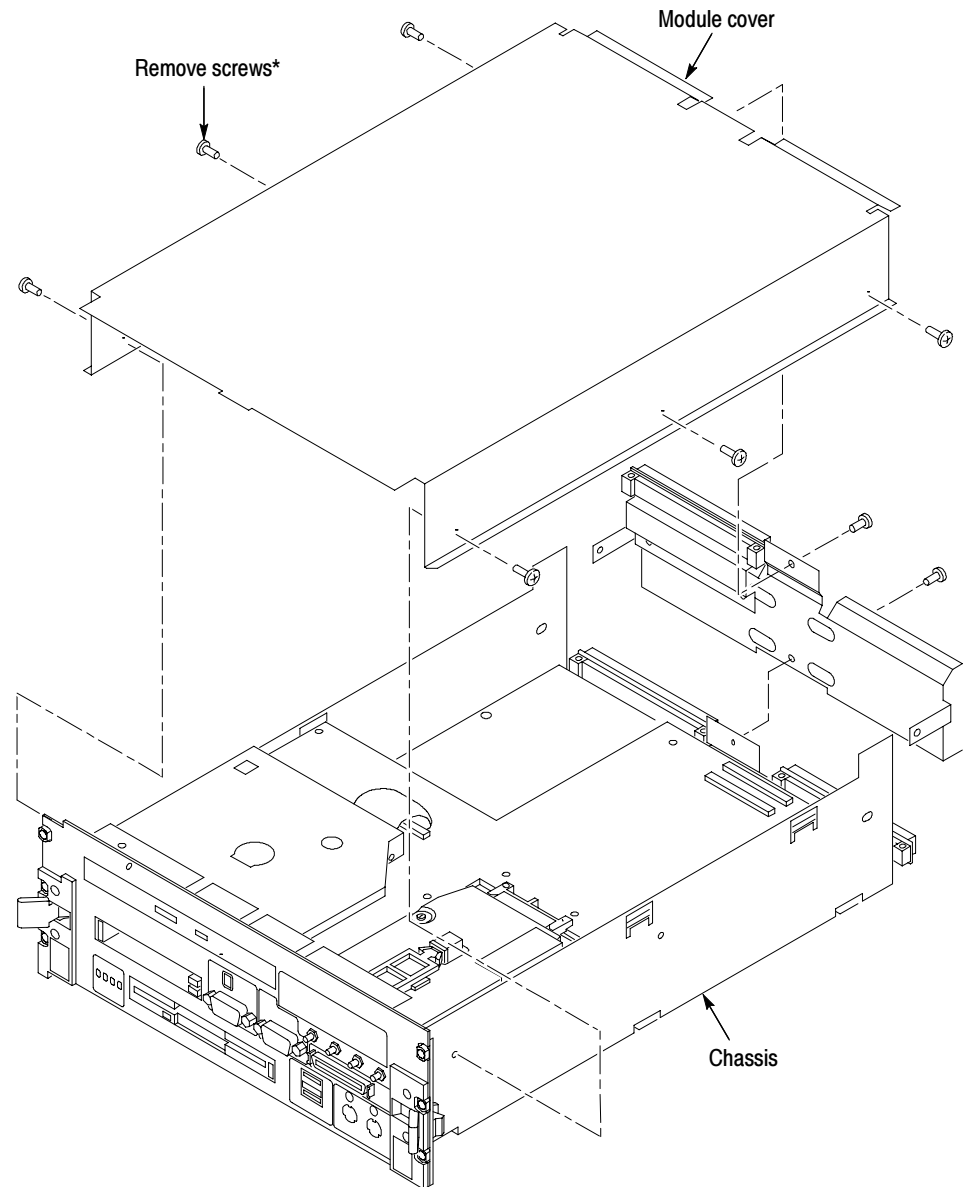

Note:* Older TLA720 controllers have eight (8) screws that hold the cover in place. Newer TLA720 controllers have ten (10) screws similar to the TLA721 controllers in Figure 10 on page 20.

Figure 4: Removing the covers from the controller

NOTE. *Earlier versions of the TLA720 Benchtop Controllers had two separate brackets for mounting the CD-RW drive. Later versions had a single bracket. If your benchtop controller has the two piece mounting bracket, continue with the following steps. If your benchtop controller has the single piece bracket, follow the instructions beginning on page 14 to remove the CD-RW drive.*

**Install the CD-RW Drive
(Older TLA720 Benchtop
Controllers)**

Complete the following steps to replace the CD-RW drive in older TLA720 Benchtop Controllers.

The CD-RW drive is located on the hard drive interface board. You can remove the CD-RW drive and the brackets without removing the hard drive interface board.

Remove the CD-RW Drive. Complete the following steps to remove the CD-RW drive and the mounting brackets:

1. Using a #0 Phillips head screwdriver with a 6-inch long shaft, remove the two screws on the side of the CD drive bracket by reaching through one of the holes in the chassis as shown in Figure 5.
2. Remove the two screws on the other side of the CD drive bracket by reaching through one of the holes of the chassis.

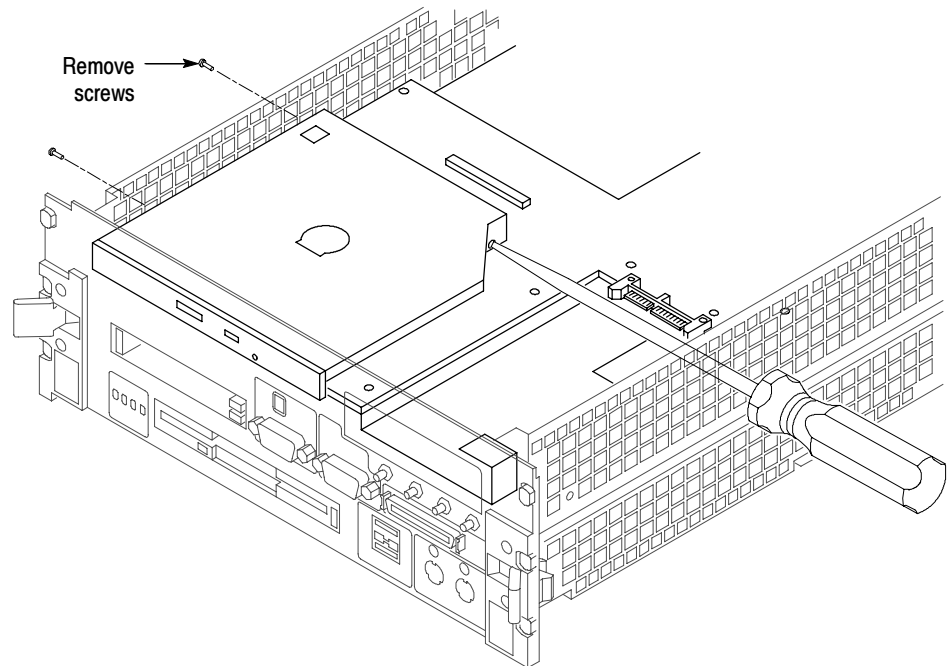

Figure 5: Remove screws from the CD drive bracket

3. Slide the CD-RW drive out of the bracket.
4. Disconnect the ribbon cable and the small interface board from the CD-RW drive. Leave the other end connected to the hard drive interface board.

Install the CD-RW Drive. Complete the following steps to install the new CD-RW drive.

1. Connect the small interface board with the drive ribbon cable to the CD-RW drive. Verify that pin-1 of the cable is connected to pin-1 of the connector.
2. Slide the new CD-RW drive into the bracket until the front of the drive is flush with the front panel.
3. Attach the CD-RW drive to the bracket using the the four screws from the removal process. (Use the long screw driver as necessary.)
4. Complete the instructions under *Reinstall the Benchtop Controller Covers* on page 17.

Install the CD-RW Drive (Newer TLA720 Benchtop Controllers)

Use the following procedures to install the CD-RW drive on newer TLA720 benchtop controllers. You will need to remove the front panel and the hard disk drive interface board to access the CD mounting bracket.

Remove the Front Panel. You must remove the front panel and the injector handles before you can access the hard disk drive interface board in the newer benchtop controllers. You will need a screwdriver with a T-10 Torx tip, a $\frac{1}{4}$ -inch nut driver, a $\frac{3}{16}$ -nut driver, and a small flat-blade screwdriver to complete the procedure.

1. Place the controller on the right side and then remove the T-10 Torx screws that secure the top and bottom handles to the chassis; remove the handles and set them aside.
2. Remove the five $\frac{1}{4}$ -inch nuts on the back of the front panel.
3. Using a small, flat-blade screw driver, remove the two screws from the printer port connector on the front panel (see Figure 6).
4. Using the $\frac{3}{16}$ -nut driver, remove the four jack screws from the video port and the COM A port connectors.
5. Pull the front panel off so that you can access the flat-head T-10 screws underneath the front panel.

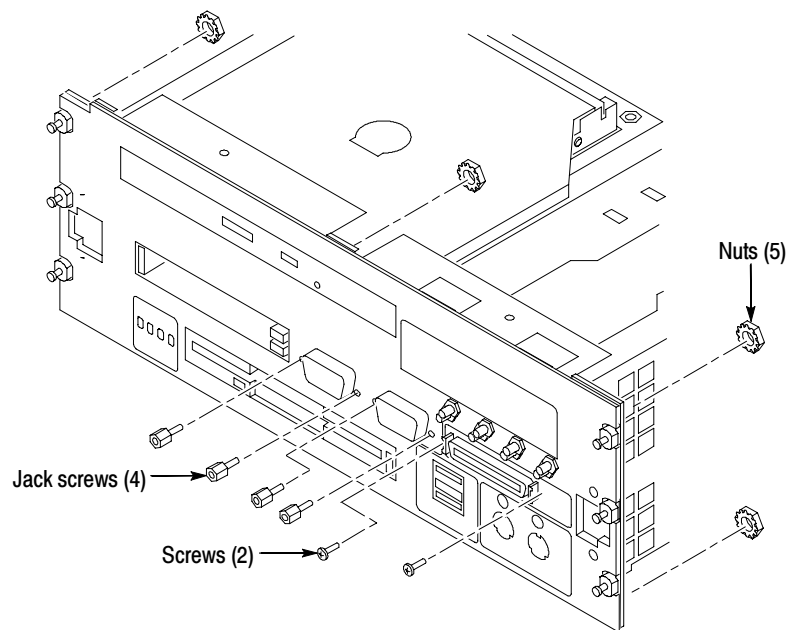

Figure 6: Removing the front panel hardware

Remove the Hard Disk Drive Interface Board. Complete the following steps to remove the hard disk drive interface board from the chassis:

1. Refer to Figure 7 and remove the four T-10 screws from the front of the controller.
2. Remove the four flat-head T-10 screws on the chassis that hold the hard drive interface board in place. See Figure 7.
3. Disconnect the two ribbon cables located on the rear of the hard disk interface board.
4. Slide the hard disk drive interface board out of the chassis.

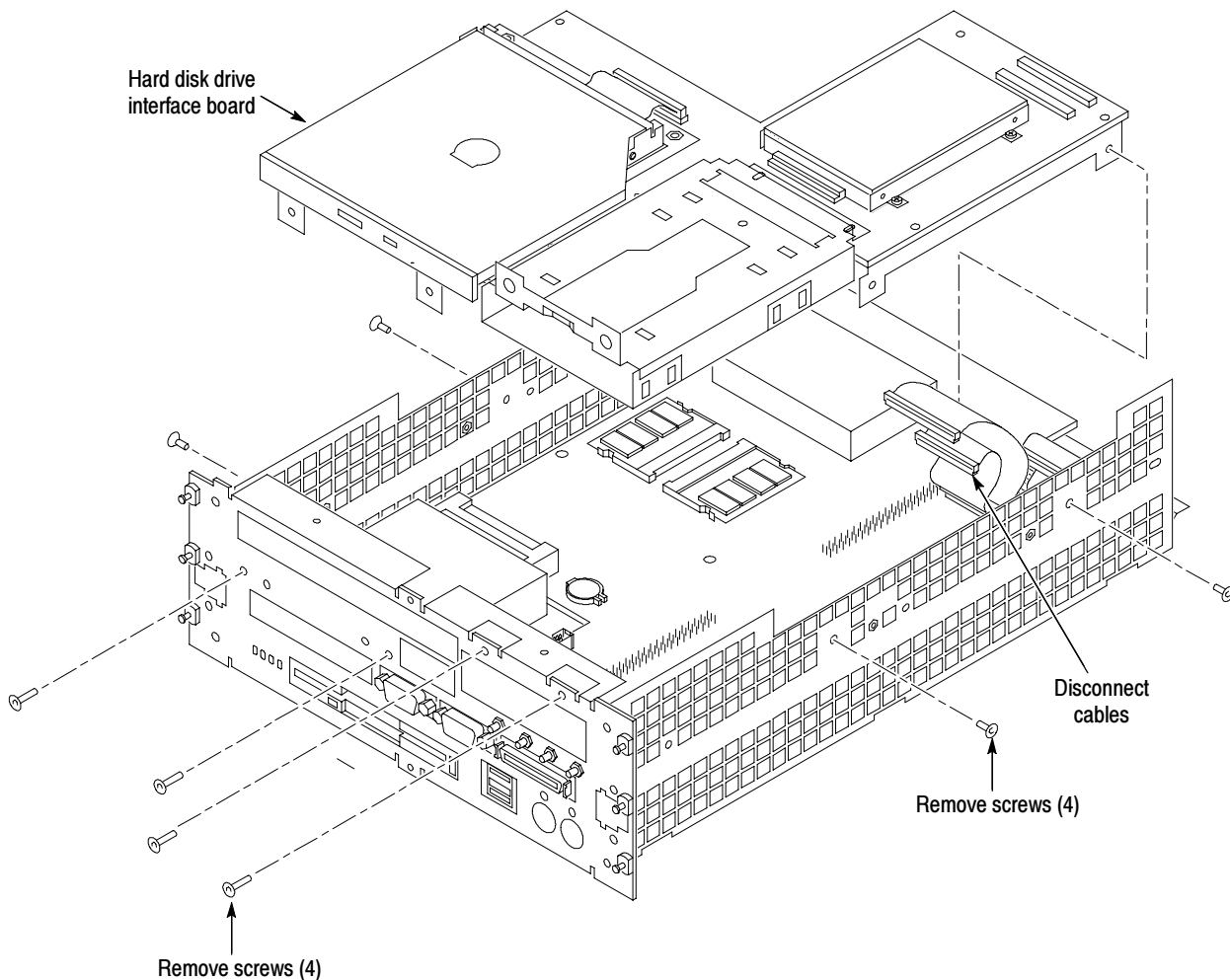

Figure 7: Removing the hard disk drive interface board from the chassis

Replace the CD-RW Drive. Complete the following steps to replace the CD-RW drive:

1. Disconnect the small interface board and ribbon cable at the rear of the CD-RW drive from the the hard disk drive interface board.
2. Using a #0 Phillips head screwdriver, remove the four screws on the sides of the CD bracket and remove the CD-RW drive assembly from the bracket.
3. Disconnect the interface board and ribbon cable from the old CD-RW drive.
4. Connect the interface board with the ribbon cable to the new CD-RW drive.
5. Slide the CD-RW drive into the bracket.
6. Attach the CD-RW drive to the bracket using the four screws that you removed earlier. Tighten the screws to 1 in-lbs.
7. Connect the ribbon cable from the small interface board at the rear of the CD-RW drive to the hard disk drive interface board.

Install the Hard Disk Drive Interface Board and Front Panel. Complete the following steps to install the hard disk drive interface board and front panel.

1. Install the hard disk drive interface board in the chassis making sure that the CD-RW drive fits into the opening at the front of the chassis.
2. Install the four flat-head T-10 screws on the top and bottom of the chassis; tighten the screws to 4 in-lbs (refer to Figure 7 on page 15 as necessary).
3. Connect the two ribbon cables from the processor board to the hard disk drive interface board.
4. Install the four flat-head T-10 screws on the front of the chassis; tighten the screws to 4 in-lbs.
5. Secure the front panel in place by lining up the five studs on the front panel with the holes on the front of the chassis. Install and tighten the five $\frac{1}{4}$ -inch nuts on the back of the front panel to 4 in-lbs.
6. Using the $\frac{3}{16}$ -nut driver, install the four jack screws to the video port and to the COM A port connectors. Tighten the jack screws to 3 in-lbs.
7. Install the two screws on the printer port connector using a small, flat-blade screw driver.

NOTE. *The top and bottom ejector handles are not interchangeable.*

8. Install the ejector handles through the front panel cutouts onto the mounting posts and then install the screws to secure the handles to the chassis.

Reinstall the Benchtop Controller Covers

1. Place the cover on the chassis. Push forward on the cover so the tab on the front edge of the cover inserts into the rear of the front subpanel. Make sure that the cover is fully seated, with no gaps, against the front and rear chassis flanges (refer to Figure 8 on page 17 as necessary).
2. Install the rear panel cover.
3. Squeeze the sides together before tightening to ensure a good EMI seal and mechanical connection.

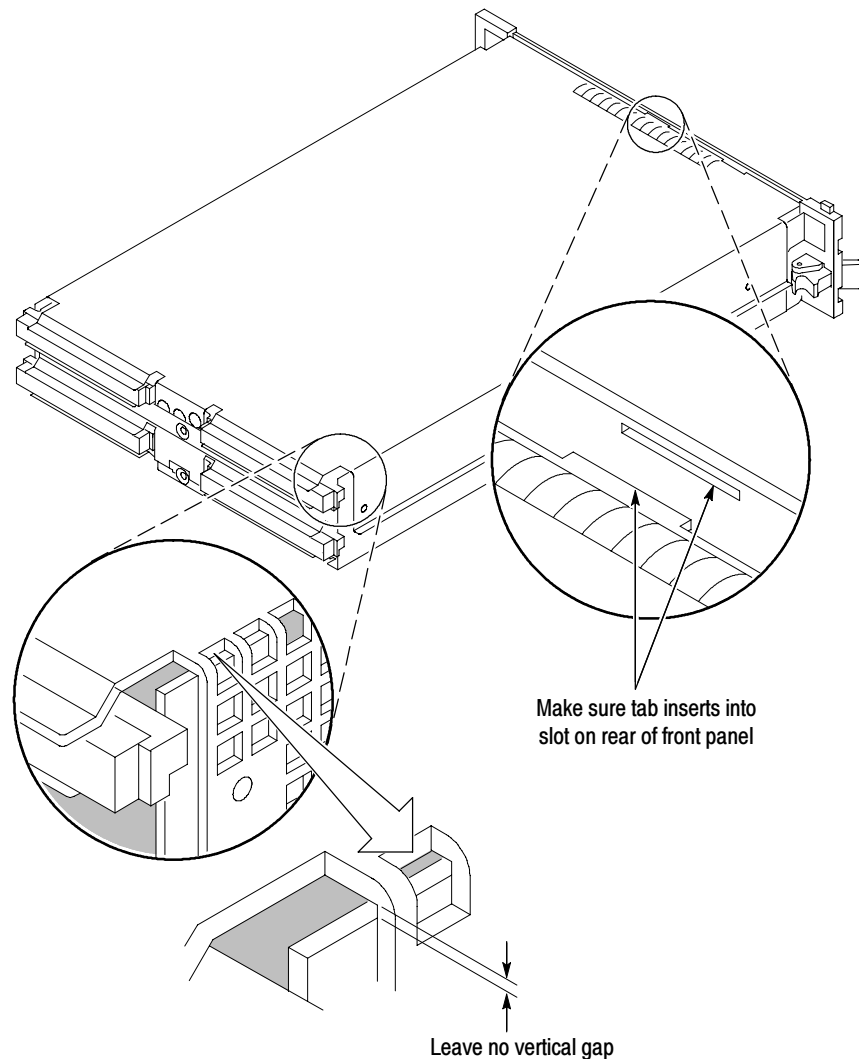

Figure 8: Seating the cover on the chassis

Reinstall the Replaceable Hard Disk

Slide the hard disk assembly into the front panel. Push on the handle until it latches in place.

Install the Controller in the Mainframe

Slide the controller into the mainframe and latch it in place. Tighten the controller hold-down screws.

Verify Operation

Go to page 24 and follow the instructions to verify the operation and (if necessary) install the software.

TLA721 CD-RW Drive Instructions

This section contains procedures for replacing the CD-RW drive in the TLA721 Benchtop controller.

These instructions require that you be familiar with servicing the instrument, because of the complexity of the Controller subassembly. If you are not familiar with servicing the instrument, you are strongly recommended to contact your nearest Tektronix service representative for installation information.



CAUTION. *Do not remove the replaceable hard disk drive or any modules while the mainframe is powered on. You can permanently damage the mainframe if you remove the hard disk drive or modules while the mainframe is powered on.*

Remove the Replaceable Hard Disk Drive

1. Power down the instrument and disconnect the power cord.
2. Press the latch on the side of the instrument to unlatch the hard disk drive.
3. Remove the hard disk drive from the instrument by pulling on the handle.

Remove the Benchtop Controller

1. If you have not already done so, power down the mainframe and disconnect the power cord.
2. Loosen the screws that secure the controller to the mainframe.
3. Disengage the benchtop controller from the mainframe using the ejector handles.
4. Remove the controller from the mainframe and place it on a static-free work surface.

Remove the Ejector Handles

You must remove the ejector handles to provide access to the front panel. The front panel contains hardware that holds the hard disk drive interface board in place.

Place the controller on the right side as shown in Figure 9. Remove the T-10 Torx screws that secure the handle to the chassis and then remove the handles.

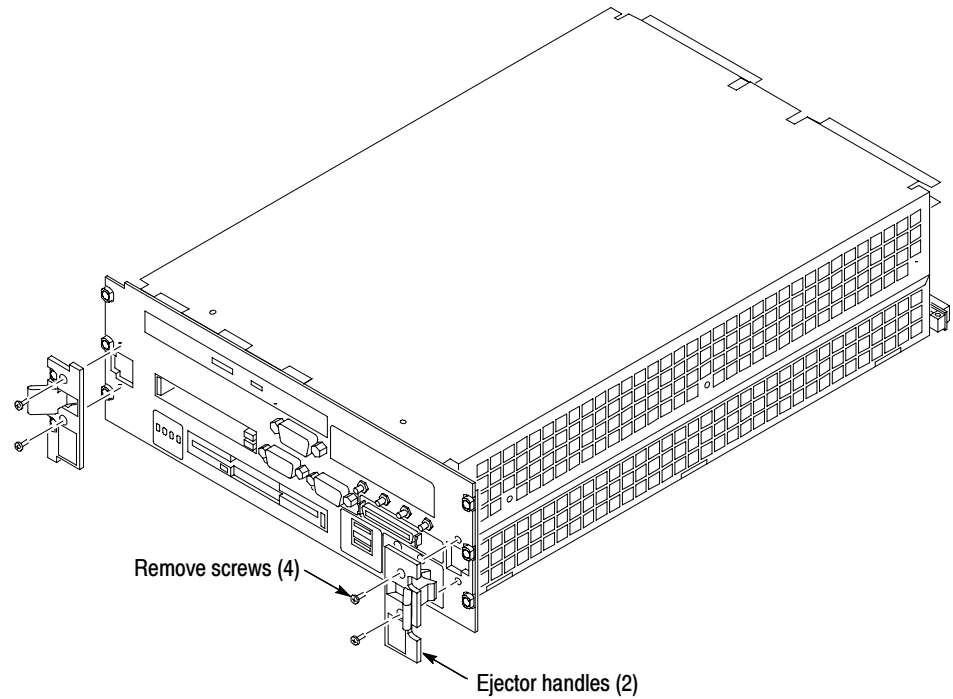

Figure 9: Removing the ejector handles

Remove the Benchtop Controller Covers

Remove the ten flat-head T-10 Torx-drive screws, shown in Figure 10, and lift off the controller left and rear covers.

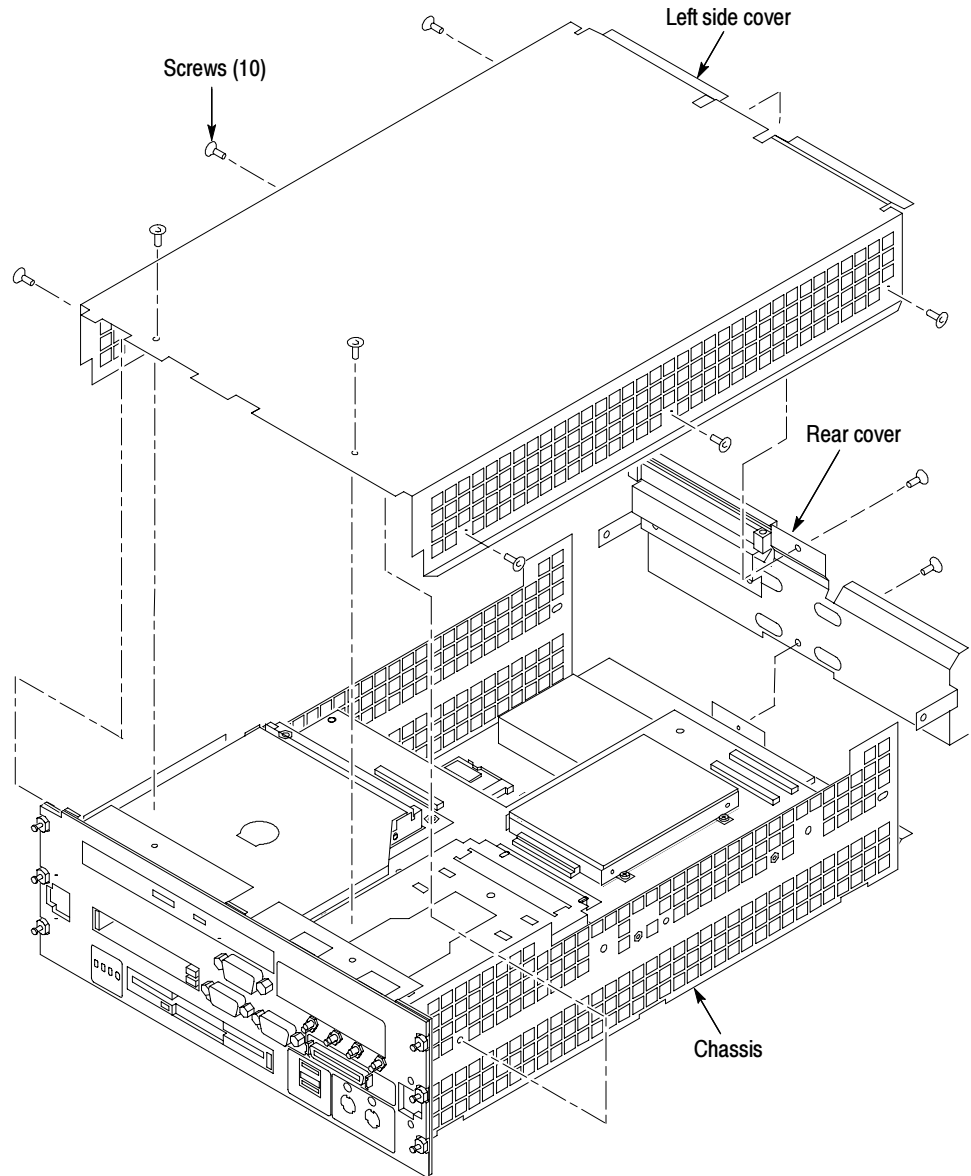

Figure 10: Removing and installing the left and rear covers

Remove the Front Panel and Hard Disk Drive Interface Board

You must remove the front panel and then the hard disk drive interface board before you can access the CD-ROM drive in the benchtop controller. You will need a screwdriver with a T-10 Torx tip, a 1/4-inch nut driver, a 3/16-inch nut driver, and a small flat-blade screwdriver to complete the procedures.

1. Remove the five $\frac{1}{4}$ -inch nuts on the back of the front panel.
2. Using a small, flat-blade screw driver, remove the two screws from the printer port connector on the front panel (see Figure 11).
3. Using the $\frac{3}{16}$ -nut driver, remove the four jack screws from the two video port connectors (do not remove the jack screws at the COM A connector).
4. Pull the front panel off so that you can access the flat-head T-10 screws underneath the front panel (be careful so that you do not damage the cable from the COM A connector).

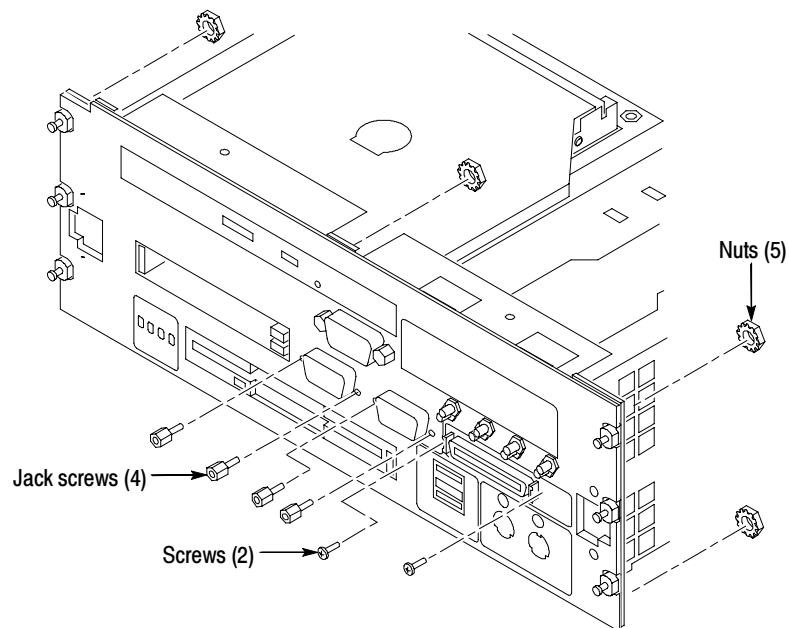

Figure 11: Removing and installing the front panel hardware

5. Refer to Figure 12 and remove the four T-10 screws from the front of the controller.
6. Remove the four flat-head T-10 screws on the bottom cover that hold the hard drive interface board in place. See Figure 12.
7. Disconnect the two ribbon cables located on the rear of the hard disk interface board.
8. Slide the hard drive interface board out of the chassis.

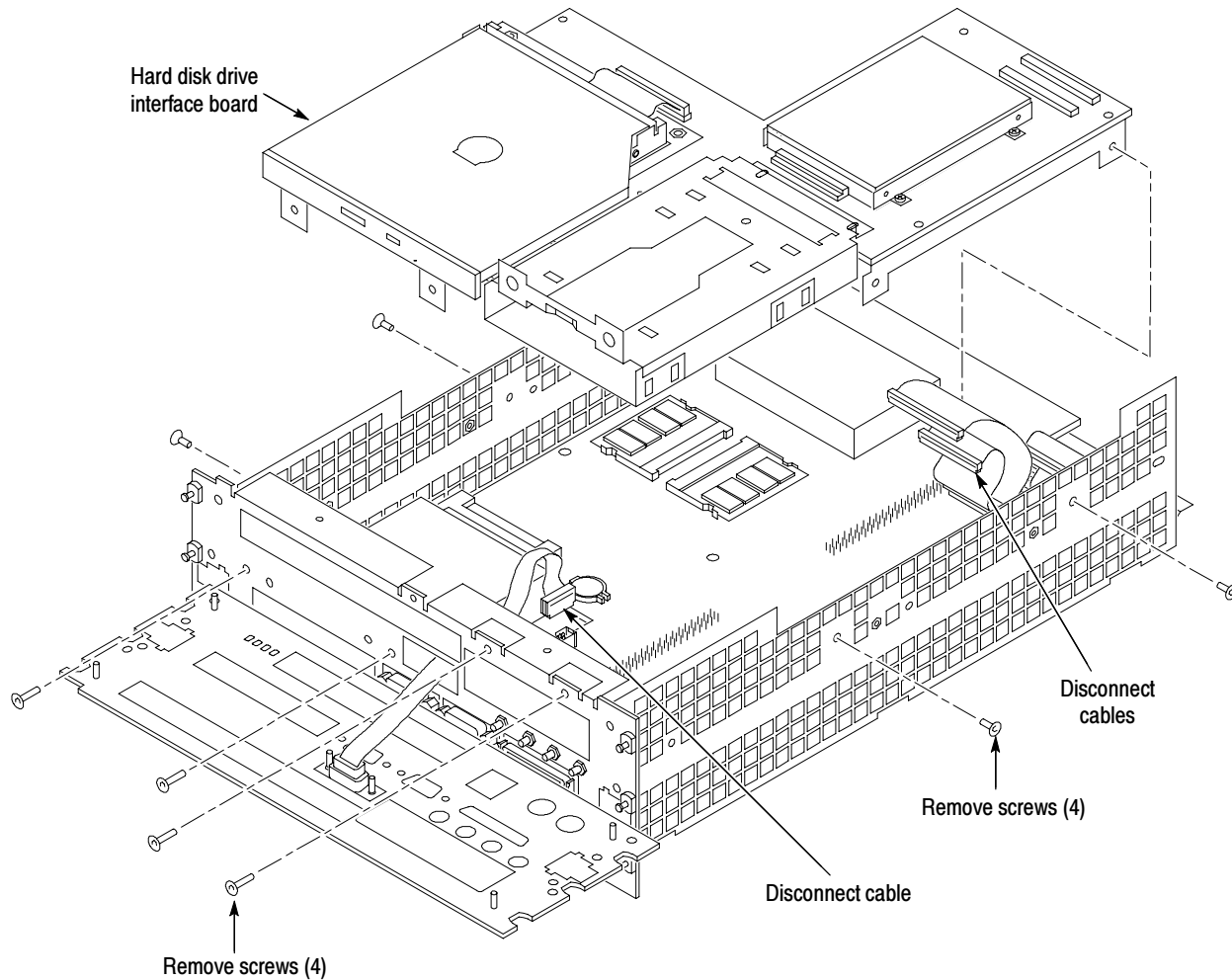

Figure 12: Removing screws from the front and sides of the controller

Replace the CD-RW Drive

1. Using a #0 Phillips head screwdriver, remove the four screws on the sides of the CD-RW bracket (see Figure 13).
2. Remove the CD-RW drive assembly from the bracket.
3. Disconnect the interface board and ribbon cable from the CD-RW drive; leave the other end of the ribbon cable connected to the hard disk drive interface board.

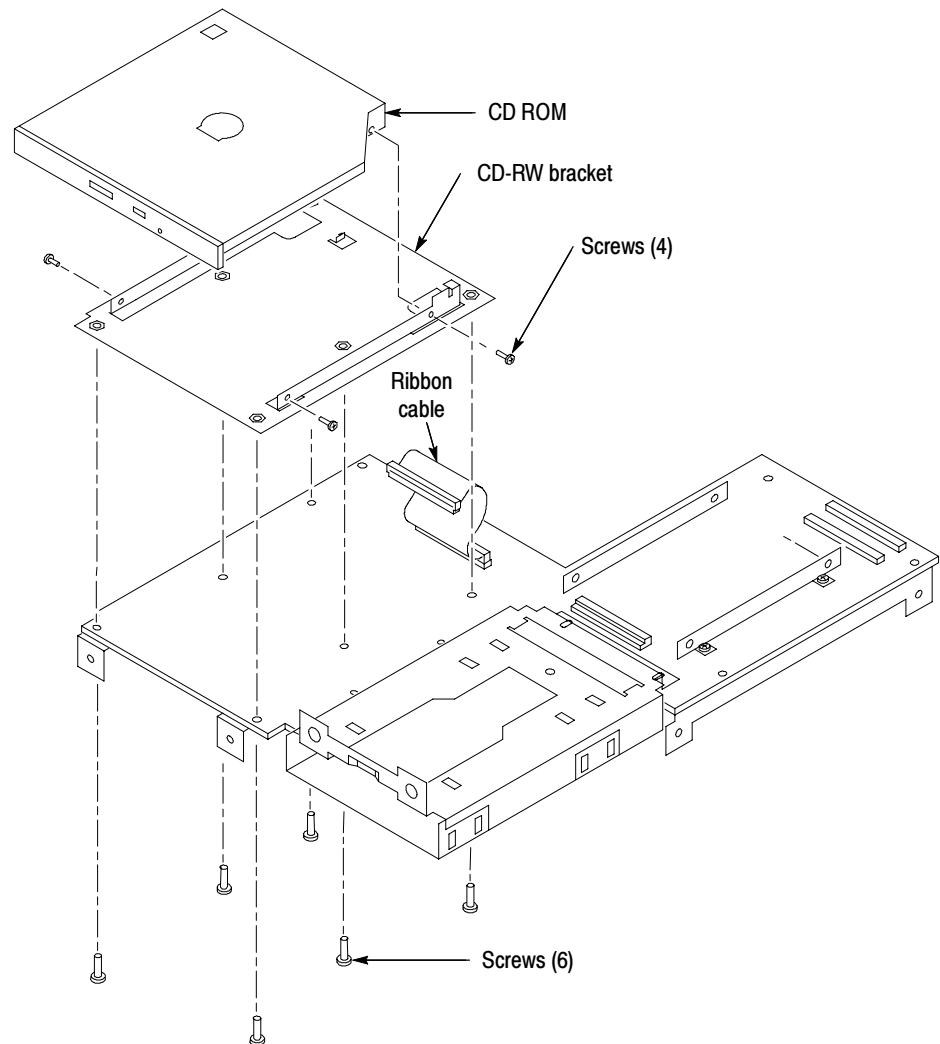

Figure 13: Removing the CD-RW drive

4. Connect the small interface board with the drive ribbon cable to the new CD-RW drive. Verify that pin-1 of the cable is connected to pin-1 of the connector.
5. Slide the CD-RW drive into the new bracket.
6. Attach the CD-RW drive to the bracket using the the four screws from the removal process. Tighten the screws to 1 in-lbs.

Reinstallation

Complete the removal instructions in reverse order to reassemble the controller module. Reinstall the module in the mainframe and latch it into place. Tighten the controller hold-down screws.

Verify Operation

1. After reassembling the instrument, reconnect the power cord and then power on the instrument.
2. Verify that the instrument passes the power-on diagnostics.
3. Insert a CD in the CD-RW drive and then use Windows Explorer to verify that you can view the contents of the CD.
4. If your instrument has Click'N Burn Pro software installed on the hard disk drive, insert the floppy disk with the Click'N Burn software patch into the floppy disk drive. Run PxEngineUpdate342.exe from the floppy disk and follow the on-screen instructions to install the patch.
5. If your instrument has the RecordNow MAX software, do not install the patch.

NOTE. *The RecordNow MAX software is available with TLA Application Software Version 4.3. You can order TLA7UP Option 32, which is a free upgrade of the TLA application software. Or, depending on your PC controller, you can purchase TLA7UP Option 31 or 33 (which includes Windows 2000 Professional and the TLA application software with the RecordNow MAX software). Contact your local Tektronix representative for ordering information.*

6. If your instrument has the NERO software installed, do not install the patch.

■ End of document ■