

**050-3712-00**  
**AG7 Output Cable and Connector Replacement**  
**Kit Instructions**

[www.tektronix.com](http://www.tektronix.com)



075-0988-00

**Tektronix**

Copyright © Tektronix. All rights reserved. Licensed software products are owned by Tektronix or its subsidiaries or suppliers, and are protected by national copyright laws and international treaty provisions.

Tektronix products are covered by U.S. and foreign patents, issued and pending. Information in this publication supersedes that in all previously published material. Specifications and price change privileges reserved.

TEKTRONIX and TEK are registered trademarks of Tektronix, Inc.

## **Contacting Tektronix**

Tektronix, Inc.  
14200 SW Karl Braun Drive  
P.O. Box 500  
Beaverton, OR 97077  
USA

For product information, sales, service, and technical support:

- In North America, call 1-800-833-9200.
- Worldwide, visit [www.tektronix.com](http://www.tektronix.com) to find contacts in your area.



# Table of Contents

Service Safety Summary..... 1  
Kit Description..... 3  
Installation Instructions ..... 4



---

# Service Safety Summary

Only qualified personnel should perform service procedures. Read this *Service Safety Summary* before performing any service procedures.

**Do Not Service Alone.** Do not perform internal service or adjustments of this product unless another person capable of rendering first aid and resuscitation is present.

**Disconnect Power.** To avoid electric shock, switch off the instrument power, then disconnect the power cord from the mains power.

**Use Care When Servicing With Power On.** Dangerous voltages or currents may exist in this product. Disconnect power, remove battery (if applicable), and disconnect test leads before removing protective panels, soldering, or replacing components.

To avoid electric shock, do not touch exposed connections.



# Kit Description

This document describes how to install the 050-3712-xx kit, to replace one of the AG7 Output cables and its associated connectors. The cable and its connectors should all be replaced at the same time.

This document supports Tektronix modification ECR32333.

**Supported Products**      **AG7**                      All S/Ns

## Minimum Tool and Equipment List

Required tools and equipment	Part number
Soldering station	Standard Equipment
$\frac{7}{16}$ inch torque wrench or driver	Standard Equipment
Pozidriv torque screwdriver	Standard Equipment

## Kit Parts List

Part number	Qty	Description
131-1315-xx	1 each	CONN,RF,JACK; BNC,PNL,50 OHM,FEMALE,STR,PELTOLA/PNL MNT,SILVER ALLOY,0.576 MLG X 0.366 TERMN,0.375-32 THD,D-FLAT
210-0012-xx	1 each	WASHER, LOCK; 0.507 OD, 0.377 ID, INT TOOTH, 0.022 THK, ZINC PLATED STEEL
220-0495-xx	1 each	NUT, PLAIN, HEX; 0.375-32 X 0.438 HEX, BRS, NI (NICKEL) PLATED
131-8438-xx	1 each	CONN,RCPT,MCX,2-POSTS,PCB,TH/SOLDER,STR,50 OHM
174-5660-xx	1 each	CA ASSY,RF; 50 OHM COAX,6.0INCH LENGTH,PELTOLA TO RA-MCX,;AG7

## Installation Instructions

These instructions assume the AG7 module has already been removed from the TG700 mainframe.

Follow this procedure to replace the output cable. Refer to the following illustration as needed. (See Figure 1.)

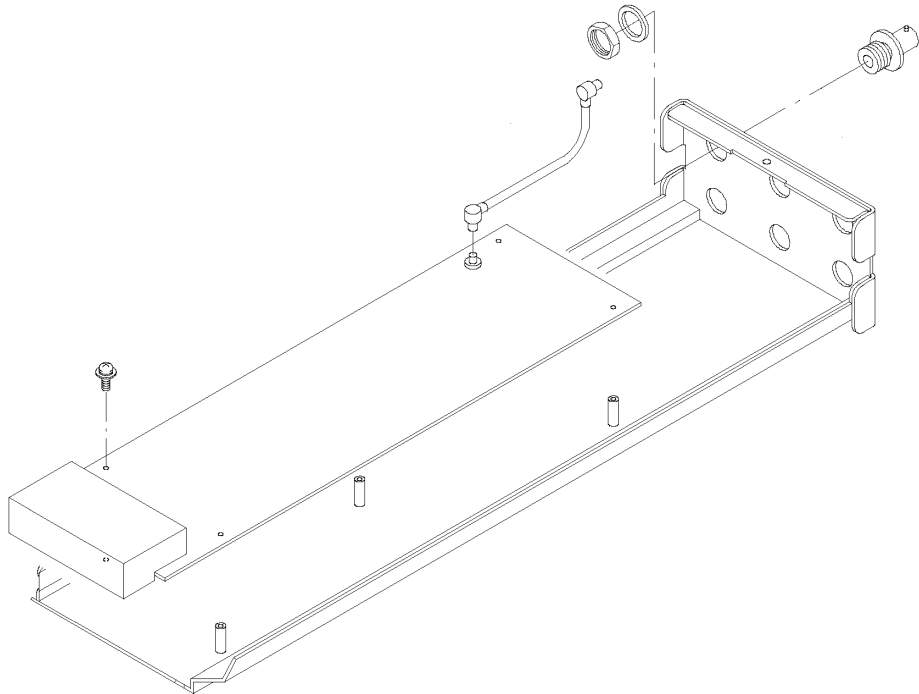

**Figure 1: Installing the cable replacement kit into the AG7 module.**

1. Unplug all of the output cables from the circuit board.
2. Remove the four screws that attach the circuit board to the chassis.
3. Unsolder and remove the connector for the cable that is being replaced.
4. Solder the new connector, provided in the kit, onto the board.

---

**NOTE.** Make sure to keep the connector straight and level while soldering it into position.

---

5. Replace the circuit board onto the chassis, torquing the four screws to 5.5 in/lb.



6. Unplug the cable being replaced from its BNC connector.
7. Use the  $\frac{7}{16}$  inch wrench to remove the nut attaching the BNC connector to the rear panel, and then remove the nut, lock washer, and BNC connector.
8. Install the new BNC, lock washer, and nut into the rear panel, torquing the nut to 22 in/lb.

---

**NOTE.** *When installed, the locking ears on the new BNC connector will be 90° from those on the original BNC connector.*

---

9. Install the new cable provided in the kit, plugging it into the new BNC and the new board connector.
10. Plug the remaining cables into the appropriate connectors on the circuit board. Make sure that they are connected to the correct connectors.

---

**NOTE.** *Be careful when plugging the cables into the connectors, especially the connectors on the circuit board. It is easy to bend the center conductor of the cable, defeating connection.*

---

This completes the kit installation.

**End of Document**