

AWG7000B and AWG7000C Series Arbitrary Waveform Generators Service Manual



077-0305-01

Tektronix

**AWG7000B and AWG7000C Series
Arbitrary Waveform Generators
Service Manual**

Copyright © Tektronix. All rights reserved. Licensed software products are owned by Tektronix or its subsidiaries or suppliers, and are protected by national copyright laws and international treaty provisions.

Tektronix products are covered by U.S. and foreign patents, issued and pending. Information in this publication supersedes that in all previously published material. Specifications and price change privileges reserved.

TEKTRONIX and TEK are registered trademarks of Tektronix, Inc.

Contacting Tektronix

Tektronix, Inc.
14150 SW Karl Braun Drive
P.O. Box 500
Beaverton, OR 97077
USA

For product information, sales, service, and technical support:

- In North America, call 1-800-833-9200.
- Worldwide, visit www.tektronix.com to find contacts in your area.

Warranty

Tektronix warrants that this product will be free from defects in materials and workmanship for a period of one (1) year from the date of shipment. If any such product proves defective during this warranty period, Tektronix, at its option, either will repair the defective product without charge for parts and labor, or will provide a replacement in exchange for the defective product. Parts, modules and replacement products used by Tektronix for warranty work may be new or reconditioned to like new performance. All replaced parts, modules and products become the property of Tektronix.

In order to obtain service under this warranty, Customer must notify Tektronix of the defect before the expiration of the warranty period and make suitable arrangements for the performance of service. Customer shall be responsible for packaging and shipping the defective product to the service center designated by Tektronix, with shipping charges prepaid. Tektronix shall pay for the return of the product to Customer if the shipment is to a location within the country in which the Tektronix service center is located. Customer shall be responsible for paying all shipping charges, duties, taxes, and any other charges for products returned to any other locations.

This warranty shall not apply to any defect, failure or damage caused by improper use or improper or inadequate maintenance and care. Tektronix shall not be obligated to furnish service under this warranty a) to repair damage resulting from attempts by personnel other than Tektronix representatives to install, repair or service the product; b) to repair damage resulting from improper use or connection to incompatible equipment; c) to repair any damage or malfunction caused by the use of non-Tektronix supplies; or d) to service a product that has been modified or integrated with other products when the effect of such modification or integration increases the time or difficulty of servicing the product.

THIS WARRANTY IS GIVEN BY TEKTRONIX WITH RESPECT TO THE PRODUCT IN LIEU OF ANY OTHER WARRANTIES, EXPRESS OR IMPLIED. TEKTRONIX AND ITS VENDORS DISCLAIM ANY IMPLIED WARRANTIES OF MERCHANTABILITY OR FITNESS FOR A PARTICULAR PURPOSE. TEKTRONIX' RESPONSIBILITY TO REPAIR OR REPLACE DEFECTIVE PRODUCTS IS THE SOLE AND EXCLUSIVE REMEDY PROVIDED TO THE CUSTOMER FOR BREACH OF THIS WARRANTY. TEKTRONIX AND ITS VENDORS WILL NOT BE LIABLE FOR ANY INDIRECT, SPECIAL, INCIDENTAL, OR CONSEQUENTIAL DAMAGES IRRESPECTIVE OF WHETHER TEKTRONIX OR THE VENDOR HAS ADVANCE NOTICE OF THE POSSIBILITY OF SUCH DAMAGES.

[W2 – 15AUG04]

Table of Contents

General Safety Summary	vi
Service Safety Summary	viii
Environmental Considerations	ix
Preface	xi
Manual Conventions	xi

Operating Information

Operating Information	1-1
-----------------------------	-----

Theory of Operation

Theory of Operation	2-1
Overview	2-1
Module Overviews	2-4

Adjustment Procedures

Adjustment Procedures	3-1
Adjustment Interval	3-1
Adjustment After Repair	3-1
Required Equipment	3-2
Adjustment Overview	3-2
Calibration Procedure	3-5

Maintenance

Maintenance	4-1
Preparation	4-1
Preventing ESD	4-1
Inspection and Cleaning	4-2
Removal and Installation Procedures	4-6
Preparation	4-6
Summary of Procedures	4-7
Required Equipment	4-8
Disconnecting and Connecting the SMP Cable	4-9
Procedures for External Modules	4-10
Procedures for Internal Modules (Upper) (AWG7000C Series)	4-21
Procedures for Internal Modules (Upper) (AWG7000B Series)	4-29
Procedures for Internal Modules (Lower)	4-39

Troubleshooting.....	4-52
Required Equipment.....	4-52
Fault Isolation Procedure	4-52
Instrument Diagnostics.....	4-57
Calibration Error.....	4-64
Hardware Error.....	4-73
After Repair	4-75
Returning the Instrument for Service.....	4-75

Replaceable Parts

Replaceable Parts.....	5-1
Parts Ordering Information	5-1
Using the Replaceable Parts List.....	5-2

List of Figures

Figure 2-1: AWG7000C Series block diagram.....	2-2
Figure 2-2: AWG7000B Series block diagram.....	2-3
Figure 3-1: AwgService UI window.....	3-3
Figure 3-2: 10 MHz Reference calibration initial test hookup	3-5
Figure 3-3: 10 MHz Reference Calibration setup window	3-6
Figure 3-4: Inter-channel skew calibration initial hookup	3-8
Figure 3-5: Inter-Channel Skew Calibration setup window	3-9
Figure 3-6: Interleave calibration initial hookup.....	3-12
Figure 3-7: Interleave Calibration window	3-13
Figure 3-8: Magic timing margin check hookup.....	3-16
Figure 3-9: Magic Timing Check dialog box.....	3-16
Figure 3-10: Example of good margin and proper timing	3-17
Figure 3-11: Example of bad waveform in magic timing margin check	3-17
Figure 4-1: Disassembly procedures for external modules and internal modules (top)	4-7
Figure 4-2: Disassembly procedures for internal modules (bottom).....	4-8
Figure 4-3: Disconnecting and connecting the SMP cable	4-9
Figure 4-4: Handle, snaps, cosmetic covers, and front-trim unit removal	4-11
Figure 4-5: EMI cover removal.....	4-14
Figure 4-6: Fan tray unit removal	4-16
Figure 4-7: Disassembly of front-panel assembly (AWG7000C Series).....	4-18
Figure 4-8: Disassembly of front-panel assembly (AWG7000B Series).....	4-20
Figure 4-9: Drive module removal (AWG7000C Series).....	4-22
Figure 4-10: Multi-Input/Output board removal (AWG7000C Series).....	4-23
Figure 4-11: Processor module removal (AWG7000C Series).....	4-25
Figure 4-12: Power Supply and RFI filter removal (AWG7000C Series).....	4-27
Figure 4-13: Power board removal (AWG7000C Series).....	4-28
Figure 4-14: Drive module removal (AWG7000B Series).....	4-30
Figure 4-15: Multi-Input/Output and Display Adapter board removal (AWG7000B Series).....	4-32
Figure 4-16: Processor module removal (AWG7000B Series).....	4-35
Figure 4-17: Power Supply and RFI filter removal (AWG7000B Series).....	4-37
Figure 4-18: Power board removal (AWG7000B Series).....	4-38
Figure 4-19: Front Connector board, CLK12G module, relay unit, and AWG12G board removal ...	4-40
Figure 4-20: Disassembly of the CLK12G module.....	4-42
Figure 4-21: Relay unit cable connection for option 02.....	4-43
Figure 4-22: Relay unit cable connection for option 06.....	4-44
Figure 4-23: Cable ties.....	4-45
Figure 4-24: Tie mount clip	4-45
Figure 4-25: Primary troubleshooting tree (1)	4-53
Figure 4-26: Primary troubleshooting tree (2)	4-54

Figure 4-27: PWR board test points.....	4-55
Figure 4-28: AWG12G board test points	4-56
Figure 4-29: Diagnostics dialog box	4-58
Figure 4-30: Calibration dialog box.....	4-64
Figure 5-1: Cosmetics.....	5-4
Figure 5-2: EMI Covers	5-5
Figure 5-3: AWG7000C Series chassis assembly.....	5-6
Figure 5-4: AWG7000B Series chassis assembly.....	5-7
Figure 5-5: AWG7000C Series front-panel assembly	5-9
Figure 5-6: AWG7000B Series front-panel assembly.....	5-11
Figure 5-7: AWG7000C Series drive modules	5-13
Figure 5-8: AWG7000B Series drive module.....	5-15
Figure 5-9: AWG7000C Series Processor module.....	5-17
Figure 5-10: AWG7000B Series processor module	5-19
Figure 5-11: AWG7000C Series power supply assembly.....	5-21
Figure 5-12: AWG7000B Series power supply assembly.....	5-23
Figure 5-13: AWG7000C Series PCI/power interface module.....	5-25
Figure 5-14: AWG7000B Series PCI/power interface module.....	5-27
Figure 5-15: Fan tray assembly.....	5-28
Figure 5-16: USB module	5-29
Figure 5-17: AWG12G/CLK12G/OUT10G modules	5-32
Figure 5-18: CLK12G module.....	5-34
Figure 5-19: AWG12G module.....	5-36
Figure 5-20: SMA bracket.....	5-38
Figure 5-21: Relay unit	5-40
Figure 5-22: Rear connectors	5-42

List of Tables

Table 3-1: Adjustments required for module replaced	3-1
Table 3-2: Test equipment	3-2
Table 4-1: External inspection checklist	4-3
Table 4-2: Internal inspection checklist	4-5
Table 4-3: Tools required for module removal and reinstall	4-8
Table 4-4: Power supply voltages	4-55
Table 4-5: PWR board voltages	4-56
Table 4-6: Diagnostics error codes	4-58
Table 4-7: Calibration error codes	4-64
Table 4-8: Hardware error codes	4-73
Table 5-1: Replaceable parts list – cosmetics	5-3
Table 5-2: Replaceable parts list – EMI covers	5-5
Table 5-3: Replaceable parts list – AWG7000C Series chassis assembly	5-6
Table 5-4: Replaceable parts list – AWG7000B Series chassis assembly	5-7
Table 5-5: Replaceable parts list – AWG7000C Series front-panel assembly	5-8
Table 5-6: Replaceable parts list – AWG7000B Series front-panel assembly	5-10
Table 5-7: Replaceable parts list – AWG7000C Series drive modules	5-12
Table 5-8: Replaceable parts list – AWG7000B Series drive module	5-14
Table 5-9: Replaceable parts list – AWG7000C Series Processor module	5-16
Table 5-10: Replaceable parts list – AWG7000B Series processor module	5-18
Table 5-11: Replaceable parts list – AWG7000C series power supply assembly	5-20
Table 5-12: Replaceable parts list – AWG7000B series power supply assembly	5-22
Table 5-13: Replaceable parts list – AWG7000C Series PCI/power interface module	5-24
Table 5-14: Replaceable parts list – AWG7000B Series PCI/power interface module	5-26
Table 5-15: Replaceable parts list – fan tray assembly	5-28
Table 5-16: Replaceable parts list – USB module	5-29
Table 5-17: Replaceable Parts List – AWG12G/CLK12G/OUT10G modules	5-30
Table 5-18: Replaceable parts list – CLK12G module	5-33
Table 5-19: Replaceable parts list – AWG12G module	5-35
Table 5-20: Replaceable parts list – SMA bracket	5-37
Table 5-21: Replaceable parts list – relay unit	5-39
Table 5-22: Replaceable parts list – rear connectors	5-41

General Safety Summary

Review the following safety precautions to avoid injury and prevent damage to this product or any products connected to it.

To avoid potential hazards, use this product only as specified.

Only qualified personnel should perform service procedures.

To Avoid Fire or Personal Injury

Use proper power cord. Use only the power cord specified for this product and certified for the country of use.

Ground the product. This product is grounded through the grounding conductor of the power cord. To avoid electric shock, the grounding conductor must be connected to earth ground. Before making connections to the input or output terminals of the product, ensure that the product is properly grounded.

Observe all terminal ratings. To avoid fire or shock hazard, observe all ratings and markings on the product. Consult the product manual for further ratings information before making connections to the product.

Do not apply a potential to any terminal, including the common terminal, that exceeds the maximum rating of that terminal.

Power disconnect. The power cord disconnects the product from the power source. Do not block the power cord; it must remain accessible to the user at all times.

Do not operate without covers. Do not operate this product with covers or panels removed.

Do not operate with suspected failures. If you suspect that there is damage to this product, have it inspected by qualified service personnel.

Avoid exposed circuitry. Do not touch exposed connections and components when power is present.

Do not operate in wet/damp conditions.

Do not operate in an explosive atmosphere.

Keep product surfaces clean and dry.

Provide proper ventilation. Refer to the manual's installation instructions for details on installing the product so it has proper ventilation.

Terms in This Manual These terms may appear in this manual:



WARNING. *Warning statements identify conditions or practices that could result in injury or loss of life.*



CAUTION. *Caution statements identify conditions or practices that could result in damage to this product or other property.*

Symbols and Terms on the Product

These terms may appear on the product:

- DANGER indicates an injury hazard immediately accessible as you read the marking.
- WARNING indicates an injury hazard not immediately accessible as you read the marking.
- CAUTION indicates a hazard to property including the product.

The following symbol(s) may appear on the product:



CAUTION
Refer to Manual



WARNING
High Voltage



Protective Ground
(Earth) Terminal



Standby

Service Safety Summary

Only qualified personnel should perform service procedures. Read this *Service Safety Summary* and the *General Safety Summary* before performing any service procedures.

Do Not Service Alone. Do not perform internal service or adjustments of this product unless another person capable of rendering first aid and resuscitation is present.

Disconnect Power. To avoid electric shock, switch off the instrument power, then disconnect the power cord from the mains power.

Use Care When Servicing With Power On. Dangerous voltages or currents may exist in this product. Disconnect power, remove battery (if applicable), and disconnect test leads before removing protective panels, soldering, or replacing components.

To avoid electric shock, do not touch exposed connections.

Environmental Considerations

This section provides information about the environmental impact of the product.

Product End-of-Life Handling

Observe the following guidelines when recycling an instrument or component:

Equipment Recycling. Production of this equipment required the extraction and use of natural resources. The equipment may contain substances that could be harmful to the environment or human health if improperly handled at the product's end of life. In order to avoid release of such substances into the environment and to reduce the use of natural resources, we encourage you to recycle this product in an appropriate system that will ensure that most of the materials are reused or recycled appropriately.



This symbol indicates that this product complies with the European Union's requirements according to Directive 2002/96/EC on waste electrical and electronic equipment (WEEE). For information about recycling options, check the Support/Service section of the Tektronix Web site (www.tektronix.com).

Mercury Notification. This product uses an LCD backlight lamp that contains mercury. Disposal may be regulated due to environmental considerations. Please contact your local authorities or, within the United States, the Electronics Industries Alliance (www.eiae.org) for disposal or recycling information. ¹

Perchlorate Materials. This product contains one or more type CR lithium coin cell batteries. According to the state of California, CR lithium coin cells are classified as perchlorate materials and require special handling. See www.dtsc.ca.gov/hazardouswaste/perchlorate for additional information.

¹ The mercury notification applies only to the AWG7000B Series instruments.

Restriction of Hazardous Substances

This product has been classified as Monitoring and Control equipment, and is outside the scope of the 2002/95/EC RoHS Directive.

Preface

This manual contains service information for your instrument. Read this preface to learn how this manual is structured, the conventions it uses, and where to find additional supplemental information related to servicing this product.

You should also read the General and Service safety summaries before servicing the product.

Manual Conventions

This manual uses certain conventions that you should become familiar with before starting service.

Modules Throughout this manual, any replaceable component, assembly, or part is referred to by the term module. A module is composed of electrical and mechanical assemblies, circuit boards, interconnecting cables, and user-accessible controls.

Replaceable Parts This manual refers to any field-replaceable assembly or mechanical part specifically by its name or generically as a replaceable part. In general, a replaceable part is any circuit board or assembly, such as the hard disk drive, or a mechanical part, such as the I/O port connectors, that is listed in the replaceable parts list of this manual.

Safety Symbols and terms related to safety appear in the Service Safety Summary at the beginning of this manual.

Operating Information

Operating Information

For information on installing, operating, and networking the instrument, refer to the *AWG5000 and AWG7000 Series Arbitrary Waveform Generators Quick Start User Manual*. This manual is available on the Document CD that came with your instrument, and on the Tektronix Web site (www.tektronix.com/manuals).

Theory of Operation

Theory of Operation

This section describes the electrical operation of the AWG7000B and AWG7000C Series Arbitrary Waveform Generators.

Overview

The Arbitrary Waveform Generators provide various models with different frequency and numbers of channels. Each model consists of two major sections: the platform and generator. The platform is common to each model.

Block Diagram of the System

The Arbitrary Waveform Generators are based on the μ ATX CPU board and components for a PC. The instrument operates with the Microsoft Window operating system. The following figures shows the system-level block diagrams.

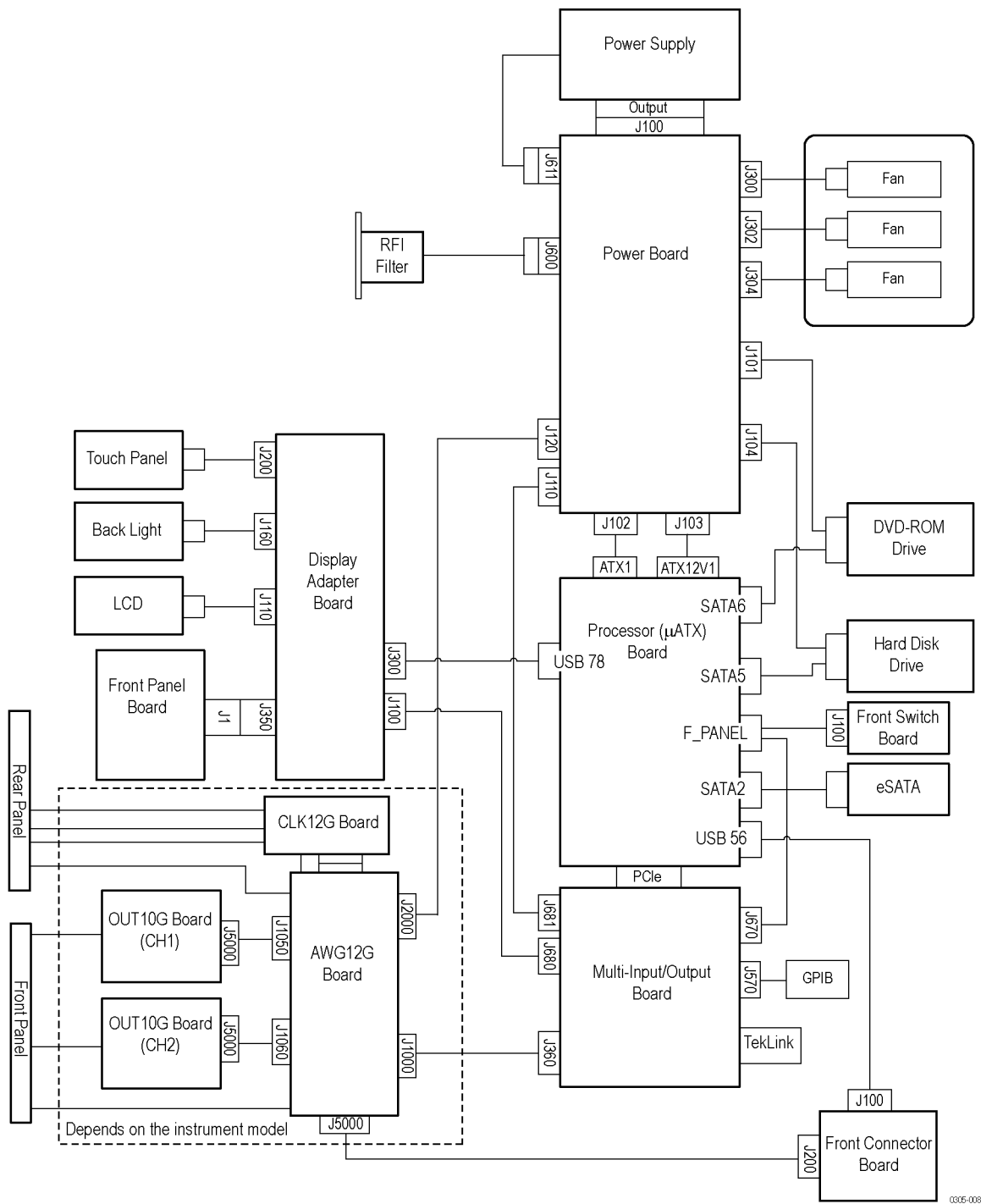

0305-008

Figure 2-1: AWG7000C Series block diagram

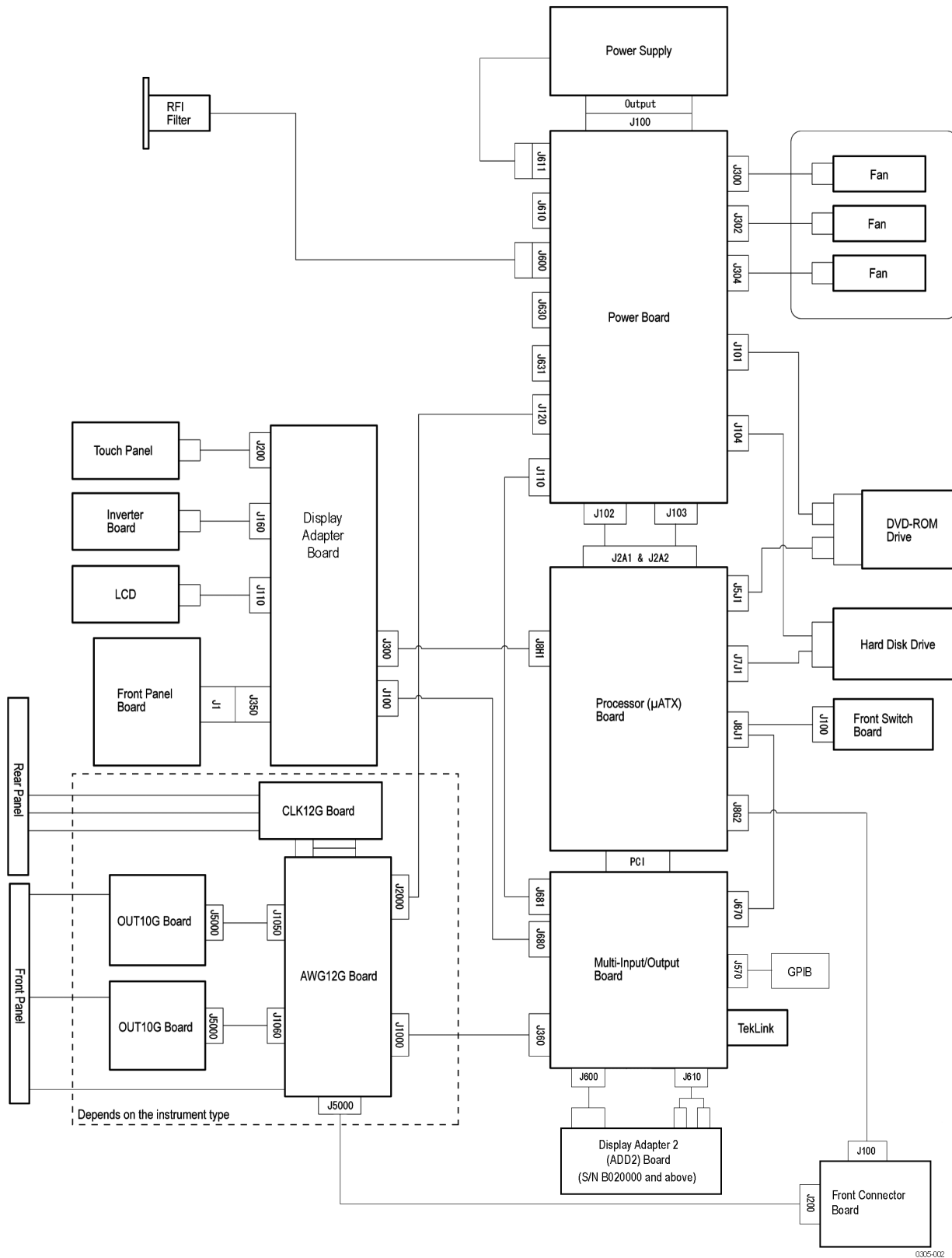

0305-002

Figure 2-2: AWG7000B Series block diagram

Module Overviews

A Microsoft Windows processor system is the primary controller of the instrument. The instrument features an XGA resolution flat-panel display, a transparent touch screen, and a front panel with direct access to commonly used instrument functions. You can also make complete use of the instrument with a mouse and a keyboard.

Front Panel (FP) Board

Push-button switches on the Front Panel (FP) board are read by an embedded microcontroller, which sends the button and knob change information to the μ ATX board via a USB path. The FP board consists of the following blocks:

- USB controller (Cypress EZ-USB FX1)
- FPGA (Altera Cyclone)
- Key switch matrix
- LED indicators (Tri-Color and Mono-Color)

Display Board

The Display board supports interconnection between the μ ATX board and FP board. Two internal USB ports come from the μ ATX board. One USB connects to a touch panel controller. The other connects to a microcontroller on the FP board. Connectors related to the LCD are also included. The Display board consists of the following blocks:

- Touch-panel controller
- Rotary encoder (signal goes to the FP board)
- Back light controller
- Connector to LCD

Multi-Input/Output (MIO) Board	<p>The MIO board coordinates the flow of data through the Windows PCIe port (PCI port for AWG7000B series) from various devices that communicate with the μATX system. The devices include the display system, GPIB, TekLink, and data flow (PCIF) path to the waveform generator system. An EEROM on this board stores the instrument settings and calibration data. The MIO board consists of the following blocks:</p> <ul style="list-style-type: none">■ PCI controller■ GPIB controller■ Display controller
	<hr/> <p>NOTE. For AWG7000B Series instruments with serial numbers below B020000, the ATI Mobility-MI circuit was included in the MIO board. For AWG7000B Series instruments with serial numbers B020000 and above, a separate display adapter board (ADD2) performs this function.)</p> <p>For AWG7000C Series instruments, the Processor board provides the video display output.</p> <hr/>
	<ul style="list-style-type: none">■ PCI target adapter■ PLD140 (Xilinx FPGA)■ EEPROM for calibration data storage■ TekLink interface
Display Adapter (ADD2) Board (AWG7000B Series)	<p>The ADD2 board contains LCD display control circuitry that processes video signals from the MIO board.</p> <p>The Display Adapter board is used with AWG7000B Series instruments serial numbered B020000 and above. This circuitry formerly resided on the MIO board.</p>
Front Switch (FSW) Board	<p>The FSW board provides interconnection between the Standby switch and μATX board. It includes an LED driver.</p>
Front Connector (FCON) Board	<p>The FCON board provides front-panel connections of the USB ports and the DC output. It includes common mode filters that suppress EMI radiation on the USB signal.</p>

- Display Panel** The active-matrix LCD display is fully controlled by Windows drivers. The display has a 1024 x 768 resolution and brightness is set to full intensity.
- For AWG7000C Series instruments, the display is controlled by the Processor board. For AWG7000B Series instruments, the display is controlled by the MIO board (or the display adapter board on AWG7000B Series instruments with serial numbers B020000 and above).
- Touch Panel** The touch information from the touch screen is processed by Windows drivers, actively placing the pointer at the touched location. Actions from the mouse and the touch panel are interchangeable, and treated alike by the user interface software. The AccuTouch resistive touch screen uses a glass panel with a uniform resistive coating. A thick polyester coversheet is tightly suspended over the top of a glass substrate, separated by small, transparent insulating dots. The coversheet has a hard, durable coating on the outer side and a conductive coating on the inner side. The controller is located on the LCDA board.
- Processor (μ ATX) Board** The μ ATX board provides standard Windows functionality and I/O port interfaces on the rear panel. This includes RS-232, Parallel, and Ethernet ports, as well as four USB ports, plus two USB2.0 ports located in the lower right front corner of the instrument. The μ ATX board receives input from the front panel and touch panel, and implements the appropriate changes. For AWG7000C Series instruments, video display data is transferred through the LVDS connector. For AWG7000B Series instruments, video display data is transferred through PCI bus interface. The hard drive is connected to the μ ATX board through the SATA interface, and the CD/DVD is connected to the Windows system through the IDE parallel interface.
- The CD/DVD drive is connected to the Windows via an interface connector on the μ ATX board. AWG7000C Series models connect using the SATA interface. AWG7000B Series models connect using the IDE parallel interface.
- Power Supply** The power supply CVR460 is a switching AC to DC converter. It automatically detects the line voltage over the range of 90 to 264 VAC. It supplies power to all the circuitry in the instrument. No switch completely disconnects the line power from the instrument. The ON/STBY switch controls the power to the instrument through the μ ATX board circuitry. When in the “power off” condition, there is still a low power standby current to allow the system to monitor the ON/STBY switch.
- Fans** Three fans on the side of the instrument provide forced air cooling. The fans are controlled by the fan speed control circuit on the PWR board and are regulated by monitoring the temperature at the circuitry.

Power (PWR) Board The PWR board provides DC power to the fans, HDD, CD Drive, μ ATX board, MIO board, and AWG12G board. All the power comes from the CVR460 module. The fan control circuit has a thermal sensor on this board. DC voltage to the fans is controlled relative to the sensed temperature. DC-DC converters are included for generating different DC voltages.

CLK12G Board The CLK12G board provides a 6 GHz to 12 GHz clock to the AWG12G board. Two clock outputs go to the CH1 and CH2 DAC. The clock output to CH2 should be terminated for 1 channel models. The clock input accepts 6 GHz to 12 GHz clock signals from an external signal source. The reference clock input accepts 10 MHz to 800 MHz reference clock signals from an external signal source. The 10 MHz reference output can be used for synchronizing frequency between two or more instruments. The CLK12G board consists of the following blocks:

- YIG oscillator (6 GHz to 12 GHz)
- Fractional-N PLL
- 10.0 MHz TCXO (reference oscillator)

AWG12G Board The AWG12G board generates arbitrary waveforms based on the waveform memory and the sequence memory. There are two types of PLDs (Xilinx FPGA) on the board. One is an AWG controller called PLD131, which interfaces to/from the MIO board. The other is a memory controller called PLD130 which generates waveform patterns. Waveform data is stored in ZBT type SRAMs. The sequence memory is included in the memory controller PLD. The AWG12G board consists of the following blocks:

- 12 GS/s DAC (HFD205 ASIC)
- 8 channels 8:1 MUX (TEK0015 ASIC)
- PLD230 (Xilinx Virtex-4 FPGA) as a memory controller
- PLD231 (Xilinx Virtex-4 FPGA) as an AWG controller
- ZBT type SRAM for the waveform memory
- Inter-channel phase detector
- Trigger and event inputs
- DC Output
- DC-DC converter (1.2 V and 2.5 V power supply)
- Dynamic Jump input (AWG7000C Series)

OUT10G1 Board for Standard Models

The OUT10G1 board provides analog and marker outputs to the front-panel connector. Amplitude, filter, offset, and On/Off controls are added to the analog outputs. High/Low voltage and On/Off controls are added to the marker outputs. The OUT10G1 board consists of the following blocks:

- Analog output amplifier
- Marker output driver
- Selectable low-pass filter
- Selectable attenuator
- Voltage monitor
- Controller PLD

OUT10G2 Board for Option 06 (and Option 02 for AWG7000B Series)

The OUT10G2 board uses the same raw board as the OUT10G1 board. The difference is that the OUT10G2 board has no analog output circuitry. The analog signal path is on the relay module. The OUT10G2 board has an analog voltage monitor. The OUT10G2 board consists of the following blocks:

- Marker output driver
- Voltage monitor
- Coax switch driver
- Controller PLD

Relay Module (Option 06) (and Option 02 for AWG7000B Series)

The relay module provides switches for analog outputs. With Option 06, the relays switch the interleaving and the analog outputs on and off. An RF power combiner is used for mixing channel 1 and 2 signals. The output of the power combiner goes to the Interleave output.

For Option 02, the relays switch the analog outputs on and off.

Adjustment Procedures

Adjustment Procedures

This section contains information about instrument adjustment. Only qualified personnel should perform adjustment procedures. Read the Service Safety Summary and the General Safety Summary before performing any service procedures.

NOTE. *Before performing adjustment procedures, you must warm up the arbitrary waveform generator at least 20 minutes in an ambient temperature between 20 °C and 30 °C. Adjustments performed before warm-up or outside this temperature range may result in poor performance.*

Adjustment Interval

If the instrument fails performance tests (refer to the *AWG7000 Series Arbitrary Waveform Generators Technical Reference Manual*), adjustment may be required.

If periodic calibration is one of your requirements, a general rule is to verify performance and make adjustments (if needed) every 2000 hours of operation (or once a year if the instrument is used infrequently).

Adjustment After Repair

After removal and replacement of a module due to electrical failure, you must perform the adjustment procedure if the module you replaced is marked “yes” in the following table. (See Table 3-1.)

Table 3-1: Adjustments required for module replaced

Module replaced	Adjustment required
Hard disk assembly	No
Fan tray unit	No
Front panel assembly	No
Drive bay module	No
MIO board	Yes
Display Adapter board	No
Processor module	No
Power supply	No
Power board	No
CLK12G module	Yes
AWG12G board	Yes
OUT10G board	Yes

Required Equipment

You will need the following equipment:

Table 3-2: Test equipment

Description	Minimum requirements	Examples	Quantity
Sampling oscilloscope	Bandwidth: 20 GHz or higher	Tektronix DSA8200 with 80E03	1 ea
Oscilloscope	Bandwidth: 1 GHz or higher	Tektronix TDS5104B	1 ea
Frequency counter	Accuracy: within ± 0.01 ppm	Agilent 53181A	1 ea
50 Ω BNC cable	DC to 2 GHz	Tektronix part number 012-0482-00	1 ea
50 Ω SMA cable	DC to 20 GHz	Tensolite 1-3636-465-5236	2 ea
50 Ω SMA Termination	DC to 18 GHz	Tektronix part number 015-1022-01	3 ea
SMA-BNC adapter	SMA female to BNC male	Tektronix part number 015-0572-00	2 ea
50 Ω SMA Attenuator	DC to 18 GHz, 12 dB	Hirose AT-112	2 ea

Adjustment Overview

The adjustment procedure contains up to ten adjustment items, depending on the instrument type and options. Before performing adjustment procedures, you must warm up the arbitrary waveform generator at least 20 minutes in an ambient temperature between 20 °C and 30 °C.

Enable the Service Menu

You must enable the Service menu to perform the adjustment procedure. To do this:

1. Power on the instrument.
2. Select the **System** menu from the menu bar, and then select **Service Mode...**
3. The following dialog box is displayed. Enter the password “1185”.

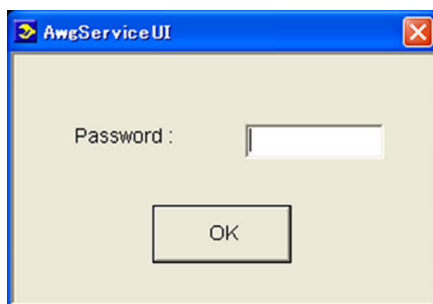

4. The AwgService UI window appears. (See Figure 3-1.)

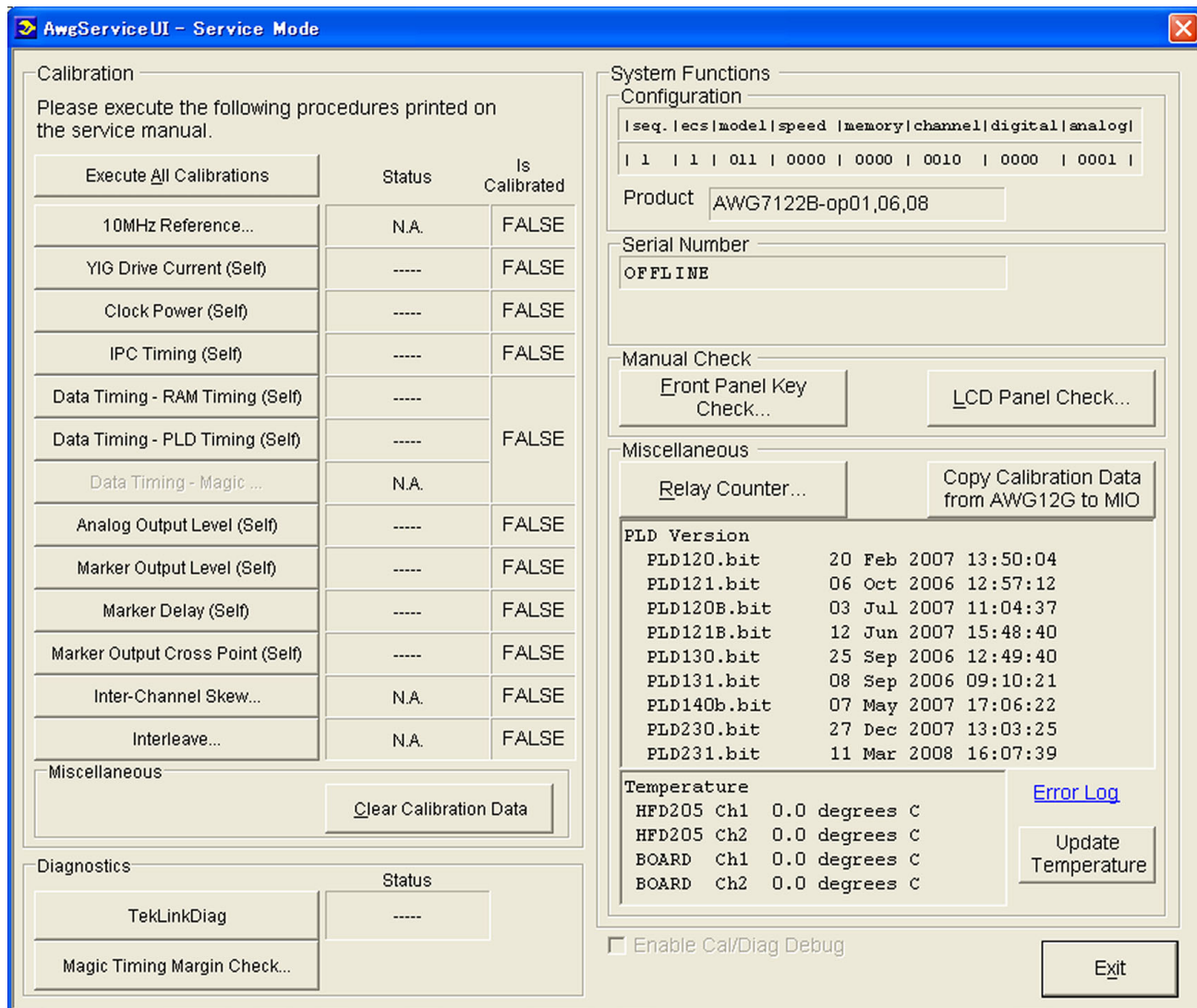

Figure 3-1: AwgService UI window

The left half of the window with the title Calibration is the calibration part of the window. You can perform the calibrations either all in one step or individually. However, since the calibration sequence is predefined, follow the sequence from the top. You must finish a calibration item listed on the upper part of the screen before performing the lower part of the items. Some items may be grayed out, depending on your instrument option configurations.

The Data Timing-Magic button is always grayed out because it can be used only in Factory Mode.

Individual Calibrations To perform individual calibrations, click the calibration buttons, starting with **10MHz Reference...**, and the corresponding calibrations are executed.

Execute All Calibrations To perform all calibrations in one step, click **Execute All Calibrations** and all calibrations are executed in order starting from the top. Instead of performing all the steps in the data timing calibration, restore and use the calibration constants obtained by the ATS (Auto Test System) at the factory or during servicing. The following procedures assume that this method will be used.

Saving the Calibration Results to EEPROM When the calibration has been performed and the results are saved to the EEPROM (regardless of the item, all results are saved to the EEPROM on the MIO board), the flag under *Is Calibrated* will be set to TRUE. If the calibration was successful, the Status field will display PASS. If the calibration failed, FAIL will be displayed.

There are two types of calibration: Self calibration and Manual calibration.

- Self calibration - The instrument performs the calibration item and ends automatically.
- Manual calibration - This calibration item requires external test equipment and manual data input. (See Table 3-2 on page 3-2.)

A warning message is displayed if you click a calibration button without waiting for 20 minutes after the instrument powered on. Click the Cancel button and allow at least 20 minutes for the instrument to warm up.

Calibration Procedure

Before starting the calibration procedure, you need to restore the calibration constants that were obtained by ATS (Automatic Test System) at the factory or the service center.

Restoring the Calibration Constants

Click the **Copy Calibration Data from AWG12G to MIO** button in the middle right of the Service UI window.

The calibration data saved to the EEPROM on the AWG12G board during the ATS calibration is restored to the EEPROM on the MIO board. The calibration data on the MIO board EEPROM is used during the following calibration procedure.

10 MHz Reference Calibration

This procedure adjusts the built-in TCXO oscillator frequency for the 10 MHz Reference Output.

Equipment required

One frequency counter
One 50 Ω BNC cable

Prerequisites

20 minute warm-up at 20 $^{\circ}$ C to 30 $^{\circ}$ C

1. Install the test hookup and preset the instrument controls:
 - a. Connect a BNC cable from the 10 MHz Reference Output on the rear panel of the arbitrary waveform generator to the CHANNEL 1 of the frequency counter. (See Figure 3-2.)

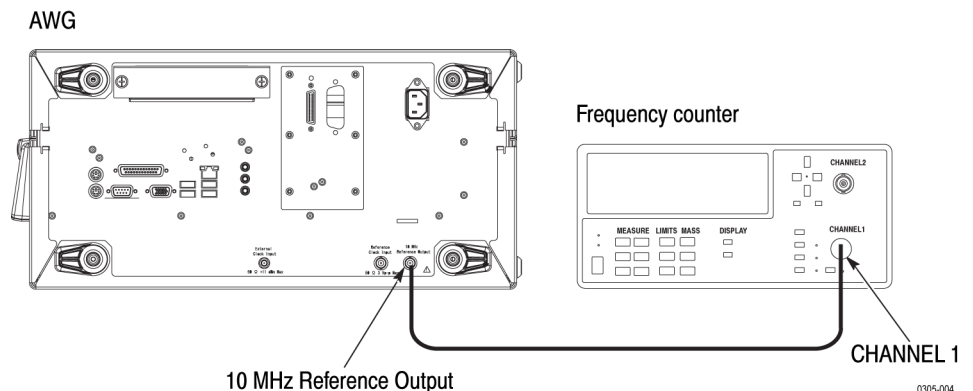

Figure 3-2: 10 MHz Reference calibration initial test hookup

2. Set the frequency counter CHANNEL 1 Impedance to **50 Ω** .

3. Click the **10MHz Reference...** button in the AwgService UI window to display the following setup window:

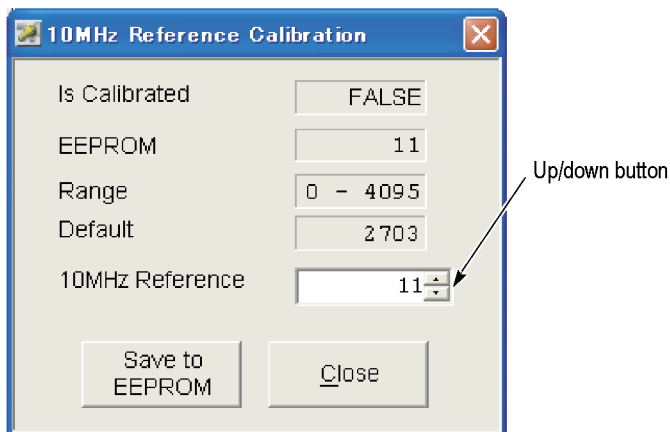

Figure 3-3: 10 MHz Reference Calibration setup window

4. Change the 10 MHz Reference value using the up/down button or the front-panel rotary knob so that the frequency counter reading is within the range of 10 MHz \pm 1 Hz.
5. Click **Save to EEPROM** to save the data to the EEPROM.
6. Click **Close** to close the window.

YIG Drive Current Calibration

This is a self calibration. The YIG for the internal clock source controls the frequency by the main coil (tuning coil) and the FM coil currents. The sensitivity differs between individual YIGs, this calibration is required to set the precise frequency.

Clock Power Calibration

This is a self calibration. In the instrument, the clock power is need to be controlled depending on the frequency so that the clock amplitude supplied from the CLK12G board to the DAC has always the proper value. If you fail to perform the calibration, the DAC does not work properly, and the AWG12G board may not work properly.

IPC Timing Calibration

This is a self calibration. The instrument features high-speed communication called IPC (Inter PLD Communication) between the internal Memory Controller and the Awg Controller. This calibration ensures the optimum timing to enable the IPC in all frequency settings. Failing to perform this calibration may disable access to the waveform memory and/or make the AWG board diagnostics cause an error.

Data Timing-RAM Timing Calibration	This is a self calibration. The instrument outputs a waveform while reading the waveform data from the internal RAM to the Memory Controller PLD. This calibration ensures the optimum timing to enable waveform outputs in all frequency settings. If you fail to perform the calibration, a waveform data may not be read from the waveform memory correctly.										
Data Timing-PLD Timing Calibration	This is a self calibration. The instrument outputs a waveform while transferring a waveform data from the Memory Controller PLD to the ASIC of the following stage. This calibration ensures the optimum timing to enable waveform outputs in all frequency settings. If you fail to perform the calibration, a waveform data cannot be transferred properly, and the waveform may not be output normally.										
Analog Output Level Calibration	This is a self calibration. This calibration ensures that the analog output levels are within the specified range.										
Marker Output Level Calibration	This is a self calibration. This calibration ensures that the marker output levels are within the specified range.										
Marker Delay Calibration	This is a self calibration. This calibration ensures that the marker delay is within the specified range.										
Marker Output Cross Point Calibration	This is a self calibration. This calibration ensures that the marker output cross point is within the specified range.										
Inter-Channel Skew Calibration (AWG7122C, AWG7082C, AWG7122B, and AWG7062B)	This calibration ensures that the Ch 1 and Ch 2 output skews are set within the specified range. This calibration is applied to both analog and marker outputs.										
	<table border="0" style="width: 100%;"> <thead> <tr> <th style="text-align: left; border-bottom: 1px solid black;">Equipment required</th> <th style="text-align: left; border-bottom: 1px solid black;">Prerequisites</th> </tr> </thead> <tbody> <tr> <td>One sampling oscilloscope</td> <td>20 minute warm-up at 20 °C to 30 °C</td> </tr> <tr> <td>Two 50 Ω SMA 12 dB attenuators</td> <td></td> </tr> <tr> <td>Two 50 Ω SMA cables</td> <td></td> </tr> <tr> <td>Three 50 Ω SMA terminations</td> <td></td> </tr> </tbody> </table>	Equipment required	Prerequisites	One sampling oscilloscope	20 minute warm-up at 20 °C to 30 °C	Two 50 Ω SMA 12 dB attenuators		Two 50 Ω SMA cables		Three 50 Ω SMA terminations	
Equipment required	Prerequisites										
One sampling oscilloscope	20 minute warm-up at 20 °C to 30 °C										
Two 50 Ω SMA 12 dB attenuators											
Two 50 Ω SMA cables											
Three 50 Ω SMA terminations											

1. Install the test hookup and preset the instrument controls:
 - a. Hook up the sampling oscilloscope:
 - Attach the SMA terminations to the Channel 1 Analog (-) Output, Channel 2 Analog (-) Output, and Marker 1 (-) Output on the front panel of the arbitrary waveform generator.
 - Connect an SMA cable from the Channel 1 Analog (+) Output on the front panel of the arbitrary waveform generator to the CH 1 Input of the sampling oscilloscope using the 12 dB SMA attenuator.
 - Connect an SMA cable from the Channel 1 Marker 1 (+) Output on the front panel of the arbitrary waveform generator to the TRIGGER DIRECT INPUT of the sampling oscilloscope using the 12 dB SMA attenuator. (See Figure 3-4.)
 - b. Set the sampling oscilloscope as follows:
 - Vertical External Attenuation: 12 dB
 - Vertical Scale: 200 mV/div
 - Horizontal Scale: 50 ps/div
 - Horizontal Timebase Mode: Lock to INT. 10 MHz
 - Trigger: External Direct Input, Level 50%
 - Acquisition: Average 64, Stop After Condition: Average Complete
 - Measurement: R1 to C1 Delay (R1/C1 Reference Level: Absolute 0.0 V)

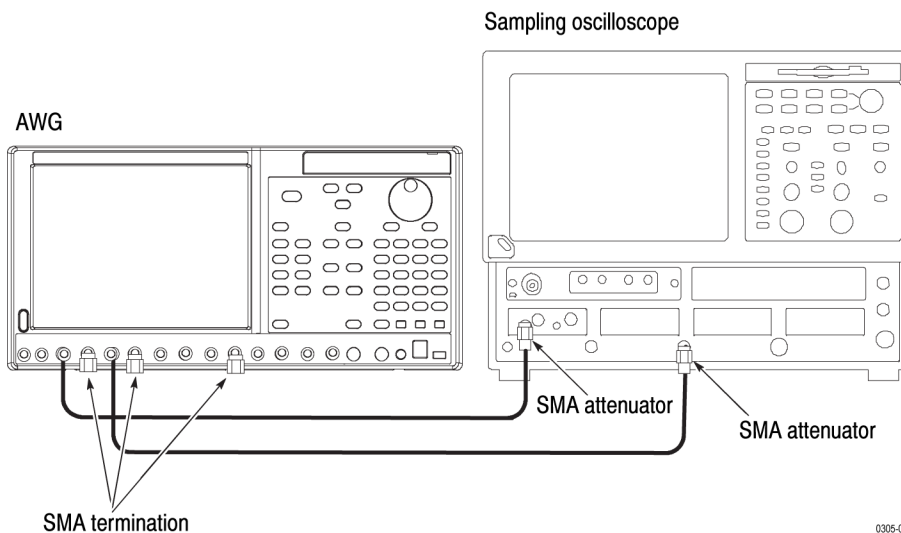

Figure 3-4: Inter-channel skew calibration initial hookup

3. Click the **Inter-Channel Skew...** button in the Service UI menu to display the following setup window:

Ch2 Phase (degree)	Delay (ps)	Ch1 - Ch2 Phase (degree)	EEPROM (degree)	Default (degree)	Ch2 Phase (degree)	Delay (ps)	Ch1 - Ch2 Phase (degree)	EEPROM (degree)	Default (degree)
180	0	0	0	177.12	-10	0	0	0	-8.64
170	0	0	0	168.48	-20	0	0	0	-17.28
160	0	0	0	162	-30	0	0	0	-25.92
150	0	0	0	153.36	-40	0	0	0	-34.56
140	0	0	0	144.72	-50	0	0	0	-43.20
130	0	0	0	136.08	-60	0	0	0	-51.84
120	0	0	0	125.28	-70	0	0	0	-60.48
110	0	0	0	116.64	-80	0	0	0	-69.12
100	0	0	0	105.84	-90	0	0	0	-77.76
90	0	0	0	92.88	-100	0	0	0	-86.40
80	0	0	0	84.24	-110	0	0	0	-95.04
70	0	0	0	75.6	-120	0	0	0	-103.68
60	0	0	0	66.96	-130	0	0	0	-112.32
50	0	0	0	56.16	-140	0	0	0	-120.96
40	0	0	0	43.2	-150	0	0	0	-129.60
30	0	0	0	32.4	-160	0	0	0	-138.24
20	0	0	0	21.6	-170	0	0	0	-146.88
10	0	0	0	10.8	-180	0	0	0	-155.52
0	0	0	0	0					

Figure 3-5: Inter-Channel Skew Calibration setup window

4. Perform the following measurements:
- Adjust the horizontal position of sampling oscilloscope so that the rising edge of the arbitrary waveform generator Ch 1 Analog (+) Output waveform is visible near the center of the oscilloscope screen, and then select File Menu > Save Waveform... to save the waveform data to R1.
 - Disconnect the SMA cable from the Ch 1 Analog (+) Output, and then connect it to the Ch 2 Analog (+) Output. Do not use a different cable for the Ch 1 and Ch 2 connectors. Always use the same SMA cable.
 - Push **CLEAR DATA** and then **RUN/STOP** on the sampling oscilloscope front panel control.

- d. Measure **R1 to C1 Delay** using the Measurement function of the sampling oscilloscope. Select the following parameters in the Inter-Channel Skew Calibration window:
 - Sampling Rate: 6.0 GHz
 - Ch 2 Phase: 0 °
- e. If the delay value measured in step d is outside ± 83 ps range, change the Sampling Rate to 12.0 GHz and then return the setting to 6.0 GHz. Measure **R1 to C1 Delay** again. Repeat this measurement until the R1 to C1 Delay value is within the ± 83 ps range.
- f. Change the parameters as follows in the Inter-Channel Skew Calibration window:
 - Sampling Rate: 6.0 GHz
 - Ch 2 Phase: +180 °
- g. Enter the measurement values of **R1 to C1 Delay** for each setting to the first place after the decimal point while changing the Ch 2 Phase settings from +180 degrees to -180 degrees using either the mouse or the Tab key. Adjust the horizontal position of the sampling oscilloscope as necessary so that the rising edge of the waveform is displayed at the center of the screen.
- h. After you complete all the measurements for **Sampling Rate: 6.0 GHz**, click **Calc (Delay to Phase)**. This will display the calculated phase values in the Ch1– Ch2 Phase (degree) field.
- i. Select **Sampling Rate: 12.0 GHz**.
- j. Disconnect the SMA cable from the Ch 2 Analog (+) Output, and then connect it to the Ch 1 Analog (+) Output.
- k. Adjust the horizontal position of the sampling oscilloscope so that the rising edge of the arbitrary waveform generator Ch 1 Analog (+) Output waveform is visible near the center of the oscilloscope screen, and then select File Menu > Save Waveform... to save the waveform data to R1.
- l. Disconnect the SMA cable from the Ch 1 Analog (+) Output, and then connect it to the Ch 2 Analog (+) Output.
- m. Change the parameters as follows in the Inter-Channel Skew Calibration window:
 - Sampling Rate: 12.0 GHz
 - Ch 2 Phase: +180 degree
- n. Enter the measurement values of **R1 to C1 Delay** for each setting to the first place after the decimal point while changing the Ch 2 Phase settings in the order from +180 degrees to -180 degrees using either the mouse or the Tab key. Adjust the horizontal position of the sampling oscilloscope

as necessary so that the rising edge of the waveform is displayed at the center of the screen.

- o. After you complete all the measurements for Sampling Rate: 12.0 GHz, click **Calc (Delay to Phase)**. This will display the calculated phase values in the Ch1–Ch2 Phase (degree) field.

5. Click **Save to EEPROM**.
6. Click **Close**. The Inter-Channel Skew Calibration window closes.

**Interleave Calibration
(AWG7122C, AWG7082C,
and AWG7122B, Option 06
only)**

This calibration ensures that the phase shift between the Ch 1 analog output and Ch 2 analog output is exactly 180 degrees at the coupler inputs.

Equipment required	Prerequisites
One sampling oscilloscope	20 minute warm-up at 20 °C to 30 °C
One 50 Ω SMA 12 dB attenuator	
Two 50 Ω SMA cables	
Two 50 Ω SMA terminations	

1. Install the test hookup and preset the instrument controls:
 - a. Hook up the sampling oscilloscope:
 - Connect an SMA cable from the Interleave (+) Output on the front panel of the arbitrary waveform generator to the CH 1 Input of the sampling oscilloscope using the 12 dB SMA attenuator.
 - Connect an SMA cable from the Channel 1 Marker 1 (+) Output on the front panel of the arbitrary waveform generator to the TRIGGER DIRECT INPUT of the sampling oscilloscope using the 12 dB SMA attenuator.
 - Attach the SMA terminations to the Interleave (–) Output and the Channel 1 Marker 1 (–) Output on the front panel of the arbitrary waveform generator. (See Figure 3-6 on page 3-12.)

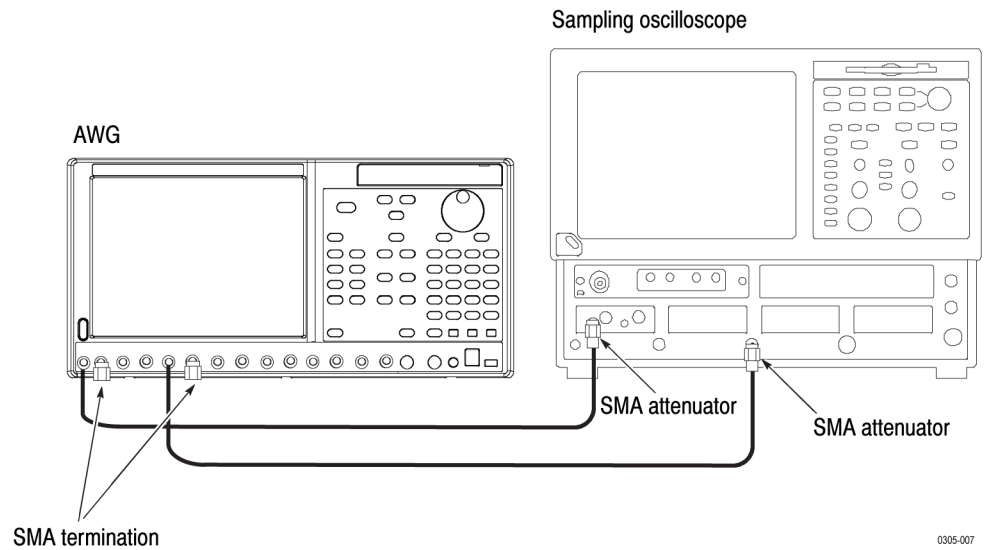

Figure 3-6: Interleave calibration initial hookup

b. Set the sampling oscilloscope as follows:

- Vertical External Attenuation: 12 dB
- Vertical Scale: 100 mV/div
- Horizontal Scale: 1 ns/div
- Horizontal Timebase Mode: Lock to INT. 10 MHz
- Trigger: External Direct Input, Level 50%
- Acquisition: Average 64
- Measurement: C1 High Level, C1 Low Level, R1-Rise to C1-Rise Delay

2. Click the **Interleave...** button in the AwgService UI window to display the Interleave Calibration window. (See Figure 3-7.)

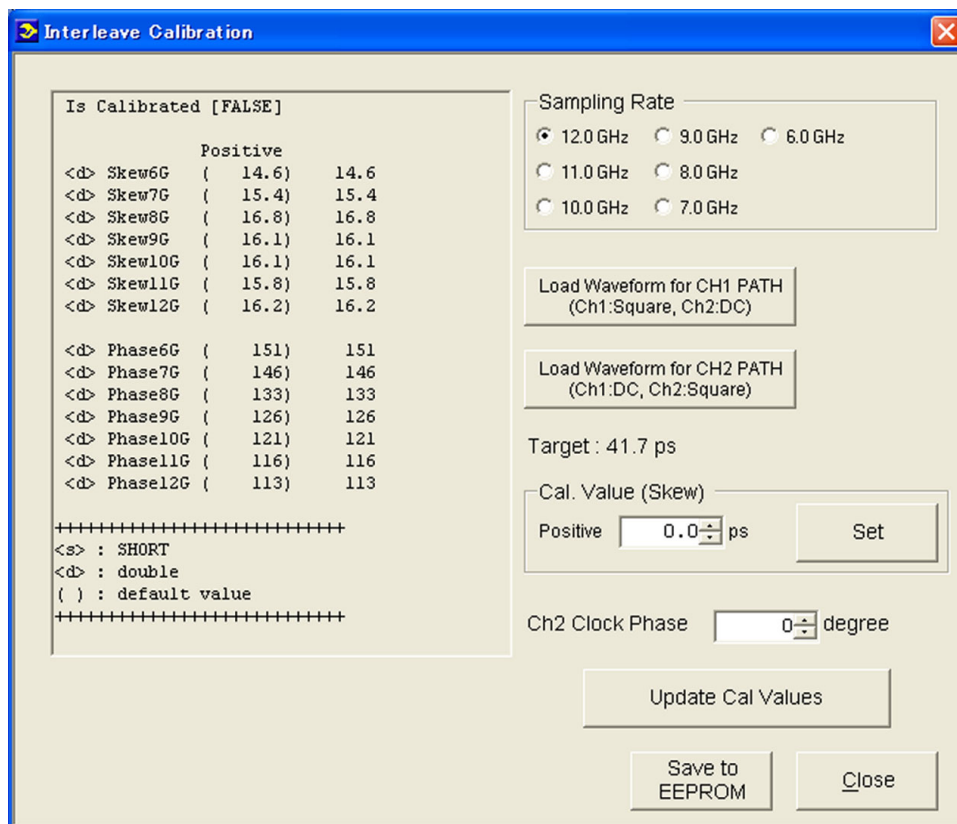

Figure 3-7: Interleave Calibration window

3. Click **Load Waveform for CH1 PATH** in the Interleave Calibration window.
4. On the sampling oscilloscope, use the vertical offset and horizontal position controls to display the waveform at the center of the screen.
5. Use the sampling oscilloscope to measure High Level and Low Level for the signal path from CH1 to Interleave Out. Note the values.
6. Click **Load Waveform for CH2 PATH** in the Interleave Calibration window.
7. Use the sampling oscilloscope to measure High Level and Low Level for the signal path from CH2 to Interleave Out. Note the values.
8. On the arbitrary waveform generator, select **12.0 GHz** in the Sampling Rate field, and then click **Load Waveform for CH1 PATH** in the Interleave Calibration window.
9. Change the horizontal scale setting on the sampling oscilloscope to **50 ps/div**.
10. On the sampling oscilloscope, use the vertical offset and horizontal position controls to display the waveform at the center of the screen.
11. Save the C1 waveform as **R1**.
12. Click **Load Waveform for CH2 PATH** in the Interleave Calibration window.

13. Use the sampling oscilloscope to measure **R1-Rise to C1-Rise Delay**.

R1 is the intermediate value between High Level and Low Level values measured in step 5, and **C1** is the intermediate value between High Level and Low Level values measured in step 7.

14. Enter the delay value in pico second to the **Cal. Value (Skew)** entry field in the Interleave Calibration window, and then click **Set**.
15. Use the up/down button or the front-panel rotary knob to adjust the **Ch2 Clock Phase** value so that the **R1-Rise to C1-Rise Delay** value on the sampling oscilloscope is $41.7 \text{ ps} \pm 2 \text{ ps}$. The target value is displayed on the middle right of the Interleave Calibration window.
16. In the same way, select the Sampling Rate 11.0 GHz, 10.0 GHz, 9.0 GHz, 8.0 GHz, 7.0 GHz, 6.0 GHz, and repeat the measurements described in step 8 through step 15. The target value varies depending on the selected Sampling Rate.
 - a. Select **11.0 GHz** in the Sampling Rate field, and then repeat the measurement. The target value is $45.5 \text{ ps} \pm 2 \text{ ps}$.
 - b. Select **10.0 GHz** in the Sampling Rate field, and then repeat the measurement. The target value is $50.0 \text{ ps} \pm 2 \text{ ps}$.
 - c. Select **9.0 GHz** in the Sampling Rate field, and then repeat the measurement. The target value is $55.6 \text{ ps} \pm 2 \text{ ps}$.
 - d. Select **8.0 GHz** in the Sampling Rate field, and then repeat the measurement. The target value is $62.5 \text{ ps} \pm 2 \text{ ps}$.
 - e. Select **7.0 GHz** in the Sampling Rate field, and then repeat the measurement. The target value is $71.4 \text{ ps} \pm 2 \text{ ps}$.
 - f. Select **6.0 GHz** in the Sampling Rate field, and then repeat the measurement. The target value is $83.3 \text{ ps} \pm 2 \text{ ps}$.
17. Click **Update Cal Values**.
18. Click **Save to EEPROM**.
19. Click **Close** to close the Interleave Calibration window.

Magic Timing Margin Check

This calibration ensures that high-speed data acquired by DAC (HFD205) have enough margin and proper timing setting.

NOTE. *If any abnormal output waveform is displayed, the instrument must be returned to Tektronix for calibration. See Contacting Tektronix, following the title page in this manual, for information on contacting Tektronix Service Support.*

Equipment required

One oscilloscope
Two SMA-BNC adapters
Two 50 Ω SMA cables
Three 50 Ω SMA terminations

Prerequisites

20 minute warm-up at 20 °C to 30 °C

1. Install the test hookup and preset the instrument controls:

NOTE. *The AWG7121B and AWG7061B are single-channel instruments and do not have a channel 2 output.*

- a. Hook up the oscilloscope:

- Connect the SMA cable from the Channel 1 Analog (+) Output on the front panel of the arbitrary waveform generator to the CH1 Input of the oscilloscope using the SMA-BNC adapter.
- Attach the SMA termination to the Channel 1 Analog (-) Output on the front panel of the arbitrary waveform generator.
- Connect the SMA cable from the Channel 2 Analog (+) Output on the front panel of the arbitrary waveform generator to the CH2 Input of the oscilloscope using the SMA-BNC adapter.
- Attach the SMA termination to the Channel 2 Analog (-) Output on the front panel of the arbitrary waveform generator. (See Figure 3-8.)

- b. Set the oscilloscope as follows:

- CH1 and CH2 Vertical Scale: 200 mV/div
- CH1 and CH2 Impedance: 50 Ω
- Horizontal Scale: 25.0 ns/div
- Trigger: Edge Trigger, CH1 Rising, Set Level to 50% (for Ch 1 Analog (+) output)
- Trigger: Edge Trigger, CH2 Rising, Set Level to 50% (for Ch 2 Analog (+) output)
- Display: Variable Persistence 500 ms

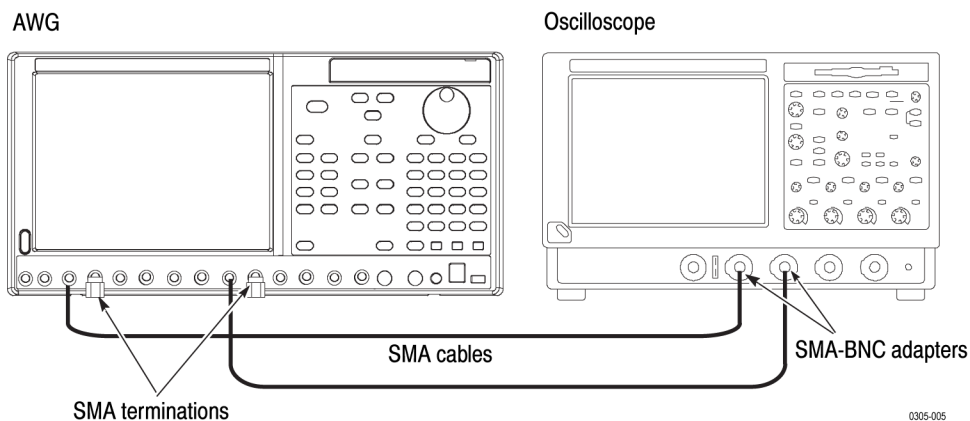

Figure 3-8: Magic timing margin check hookup

2. Click **Magic Timing Margin Check...** in the AwgServiceUI window to display the Magic Timing Check dialog box.

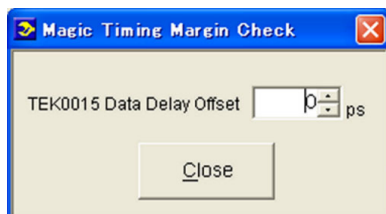

Figure 3-9: Magic Timing Check dialog box

3. Set TEK0015 Data Delay Offset to **0** ps, and then verify that a sine wave is properly displayed on the oscilloscope screen (approximately 1.0 V amplitude and 85 ns period). Check waveforms for both Channel 1 and Channel 2 Analog outputs.
4. Set TEK0015 Data Delay Offset to **60** ps, and then check that a sine wave is properly displayed on the oscilloscope screen. Check waveforms for both Channel 1 and Channel 2 Analog outputs.
5. Set TEK0015 Data Delay Offset to **-60** ps, and then check that a sine wave is properly displayed on the oscilloscope screen. Check waveforms for both Channel 1 and Channel 2 Analog outputs.

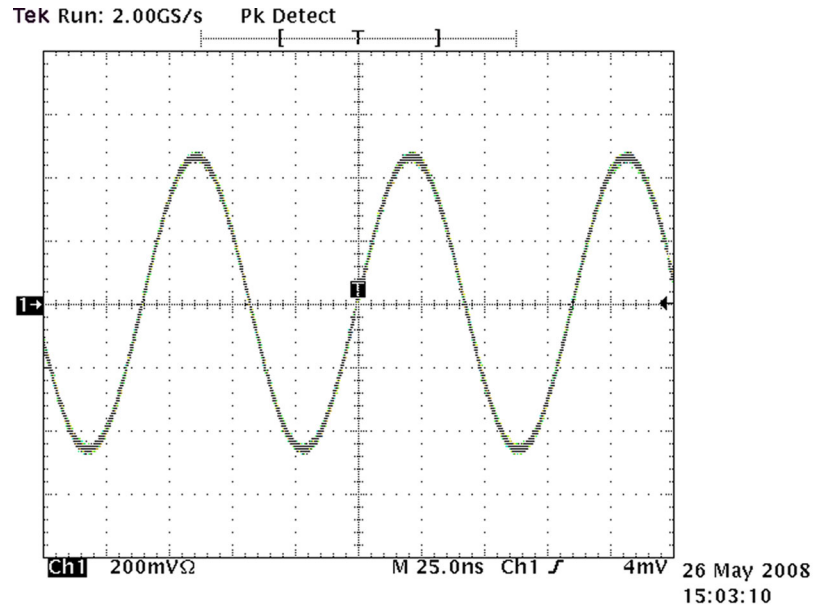

Figure 3-10: Example of good margin and proper timing

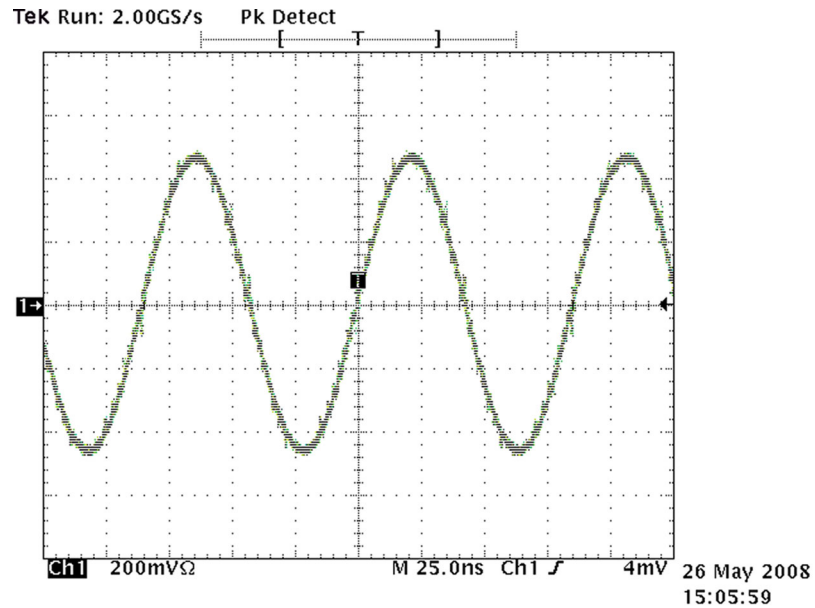

Figure 3-11: Example of bad waveform in magic timing margin check

6. Click **Close** in the Magic Timing Margin Check dialog box.
7. Click **Exit** in the AwgServiceUI window.

This completes the adjustment procedures. Disconnect the equipment from the instrument.

Maintenance

Maintenance

This section contains information needed to do periodic and corrective maintenance on the instrument. The following subsections are included:

- *Preparation* – Tells you how to prepare for arbitrary waveform generator maintenance.
- *Preparation Preventing ESD* – Provides general information on preventing damage to internal modules when doing maintenance.
- *Inspection and Cleaning* – Information and procedures for inspecting the instrument and cleaning its external and internal modules.
- *Removal and Installation Procedures* – Procedures for the removal of defective modules and installation of new or repaired modules.
- *Troubleshooting* – Information for isolating failed modules. Included are instructions for operating the instrument diagnostic routines and troubleshooting trees. Most of the trees make use of the internal diagnostic routines to speed fault isolation to a module.

Preparation

Only qualified persons should perform service procedures. Before performing any service procedures, read the *Service Safety Summary* and *General Safety Summary* at the front of this manual and the ESD information below. Also refer to the Operating Information section and your arbitrary waveform generator quick start user manual for information about using the arbitrary waveform generator.

Preventing ESD

When performing any service that requires internal access to this instrument, adhere to the following precautions to avoid damaging internal modules and their components due to electrostatic discharge (ESD).



CAUTION. *Static discharge can damage any semiconductor component in this instrument.*

- Minimize handling of static-sensitive modules.
- Transport and store static-sensitive modules in their static protected containers or on a metal rail. Label any package that contains static-sensitive modules.
- Discharge the static voltage from your body by wearing a grounded antistatic wrist strap while handling these modules. Service static-sensitive modules only at a static-free work station.

- Do not allow anything capable of generating or holding a static charge on the work station surface.
- Handle circuit boards by the edges when possible.
- Do not slide the modules over any surface.
- Avoid handling modules in areas that have a floor or work-surface covering capable of generating a static charge.

Inspection and Cleaning

Inspection and Cleaning describes how to inspect for dirt and damage, and how to clean the exterior and interior of the instrument. Inspection and cleaning are done as preventive maintenance. Preventive maintenance, when done regularly, may prevent instrument malfunction and enhance its reliability.

Preventive maintenance consists of visually inspecting and cleaning the instrument and using general care when operating it.

How often to do maintenance depends on the severity of the environment in which the instrument is used. A proper time to perform preventive maintenance is just before instrument adjustment.

General Care

For optimum performance, follow these recommendations:

- Protect the instrument from adverse weather conditions. The instrument is not waterproof.
- Do not store or leave the instrument where the liquid crystal display (LCD) will be exposed to direct sunlight or high humidity for long periods of time.
- The cabinet helps keep dust out of the instrument and must be in place during normal operation.
- To avoid damage to the instrument, do not expose it to any sprays, liquids, or solvents.

Inspection and Cleaning procedures

The collection of dirt on internal components can cause them to overheat and fail. Dirt also provides an electrical conduction path that could cause an instrument failure, especially under high-humidity conditions. Inspect the instrument as often as operating conditions require.



WARNING. Before performing any of the following procedures, power down the instrument and disconnect it from line voltage.



CAUTION. Avoid the use of chemical cleaning agents, which might damage the plastics used in this instrument. Use only deionized water when cleaning the front-panel buttons. Use an ethyl alcohol solution as a cleaner and rinse with deionized water.

Inspection – Exterior. Inspect the outside of the instrument for damage, wear, and missing parts, using the following table as a guide. An instrument that appears to have been dropped or otherwise abused should be checked thoroughly to verify correct operation and performance. Immediately repair defects that could cause personal injury or further damage to the instrument.

Table 4-1: External inspection checklist

Item	Inspect for	Repair action
Cabinet, front-panel, and cover	Cracks, scratches, deformations, damaged hardware or gaskets.	Repair or replace defective module.
Front-panel knob	Missing, damaged, or loose knob.	Repair or replace missing or defective knob.
Connectors	Broken shells, cracked insulation, and deformed contacts. Dirt in connectors.	Repair or replace defective modules. Clear or wash out dirt.
Carrying handle and cabinet feet	Correct operation.	Repair or replace defective module.
Accessories	Missing items or parts of items, bent pins, broken or frayed cables, and damaged connectors.	Repair or replace damaged or missing items, frayed cables, and defective modules.

Cleaning Procedure – Exterior. Do the following steps to clean the instrument exterior:

1. Remove loose dust on the outside of the instrument with a lint-free cloth. Use care to avoid scratching the clear glass display shield.
2. Remove remaining dirt with a lint-free cloth dampened in a general purpose detergent-and-water solution. Do not use abrasive cleaners.



CAUTION. *To prevent getting moisture inside the instrument during external cleaning, use only enough liquid to dampen the cloth or applicator.*

NOTE. *To avoid damage to the surface of the instrument, do not use any abrasive or chemical cleaning agents.*

Flat Panel Display Cleaning. The display is a soft plastic display and must be treated with care during cleaning.



CAUTION. *Improper cleaning agents or methods can damage the flat panel display.*

Avoid using abrasive cleaners or commercial cleaners to clean the display surface.

Avoid spraying liquids on the display surface.

Avoid scrubbing the display with excessive force.

1. Clean the flat panel display surface by gently rubbing the display with a clean-room wipe (such as Wypall Medium Duty Wipes, #05701, available from Kimberly-Clark Corporation).
2. If the display is very dirty, moisten the wipe with distilled water or a 75% isopropyl alcohol solution and gently rub the display surface. Avoid using excess force or you may damage the plastic display surface.



CAUTION. *To prevent getting moisture inside the instrument during external cleaning, use only enough liquid to dampen the cloth or applicator.*

Inspection – Interior. Inspect and clean the interior if it appears that the instrument may have been damaged or exposed to an unusually dirty environment.

To access the inside of the instrument for inspection and cleaning, refer to the Removal and Installation Procedures in this section.

Inspect the internal portions of the instrument for damage and wear, using the following table as a guide. Defects should be repaired immediately.



CAUTION. To prevent damage from electrical arcing, ensure that circuit boards and components are dry before applying power to the instrument.

Table 4-2: Internal inspection checklist

Item	Inspect for	Repair action
Front and Rear Case	Cracks or deformations. Scratched lettering or display filter. Loose connectors or labels.	Repair or replace defective hardware.
Circuit boards	Loose, broken, or corroded solder connections. Burned circuit boards. Burned, broken, or cracked circuit-run plating.	Remove failed module and replace with a new module.
Solder connections	Cold solder or rosin joints.	Resolder joint and clean with ethyl alcohol.
Wiring and cables	Loose plugs or connectors. Burned, broken, or frayed wiring.	Firmly seat connectors. Repair or replace modules with defective wires or cables.
Chassis	Dents, deformations, and damaged hardware.	Straighten, repair, or replace defective hardware.

Cleaning Procedure – Interior. Do the following steps to clean the instrument interior:

1. Blow off dust with dry, low-pressure, deionized air (approximately 9 psi).
2. Remove any remaining dust with a lint-free cloth dampened in isopropyl alcohol (75% solution) and rinse with warm deionized water. (A cotton-tipped applicator is useful for cleaning in narrow spaces and on circuit boards.)

NOTE. If steps 1 and 2 do not remove all the dust or dirt, please contact Tektronix. (See *Contacting Tektronix at the front of this manual.*)

Lubrication. There is no periodic lubrication required for the instrument.

Removal and Installation Procedures

This section contains procedures for removal and installation of all mechanical and electrical modules.

Preparation



WARNING. *Only qualified personnel should perform service procedures.*

Before performing this or any other procedure in this manual, read the General Safety Summary and Service Safety Summary found at the beginning of this manual. To prevent possible injury to service personnel or damage to the instrument components, read Preventing ESD in this section.

This section contains the following items:

- This preparatory information that you need to properly do the following procedures.
- List of tools required to remove and disassemble all modules.
- Procedures for removal and reinstallation of the modules.



WARNING. *Before doing any procedure in this section, disconnect the power cord from the line voltage source. Failure to do so could cause serious injury or death.*

NOTE. *Read Equipment Required for a list of the tools needed to remove and install modules in this instrument. (See page 4-8, Required Equipment.) Read the cleaning procedure before disassembling the instrument for cleaning.*

Adjustment After Repair

After the removal and replacement of a module due to electrical failure, perform the adjustment procedures. (See page 3-1, *Adjustment Procedures*.)

List of Modules

The Replaceable Parts section provides a list of all replaceable modules.

Summary of Procedures

Disassembly for replacement is best achieved by removing and replacing the modules in a specific order. Complete disassembly is best achieved by the following procedures in the order given in the following figures.

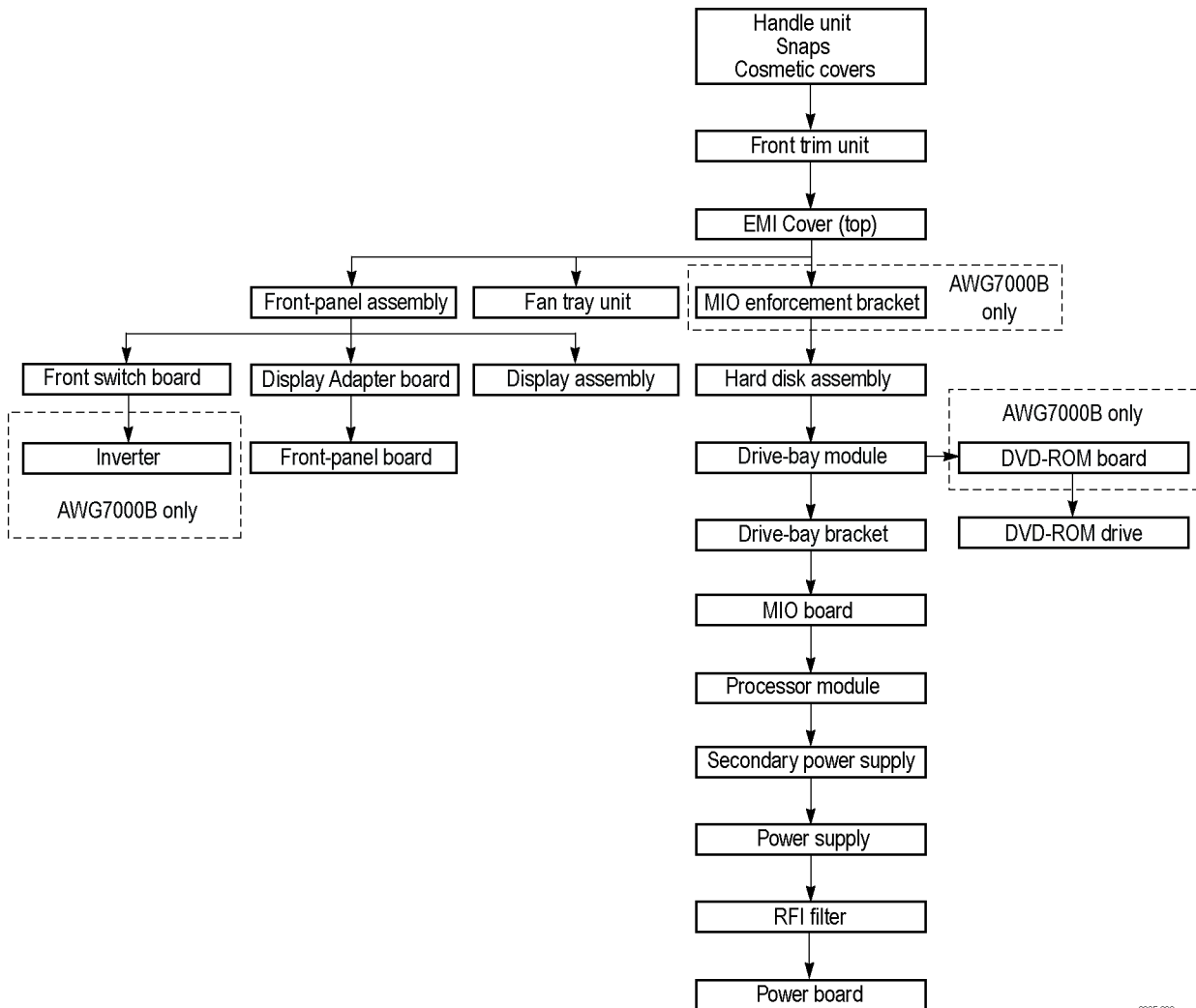

0005-003

Figure 4-1: Disassembly procedures for external modules and internal modules (top)

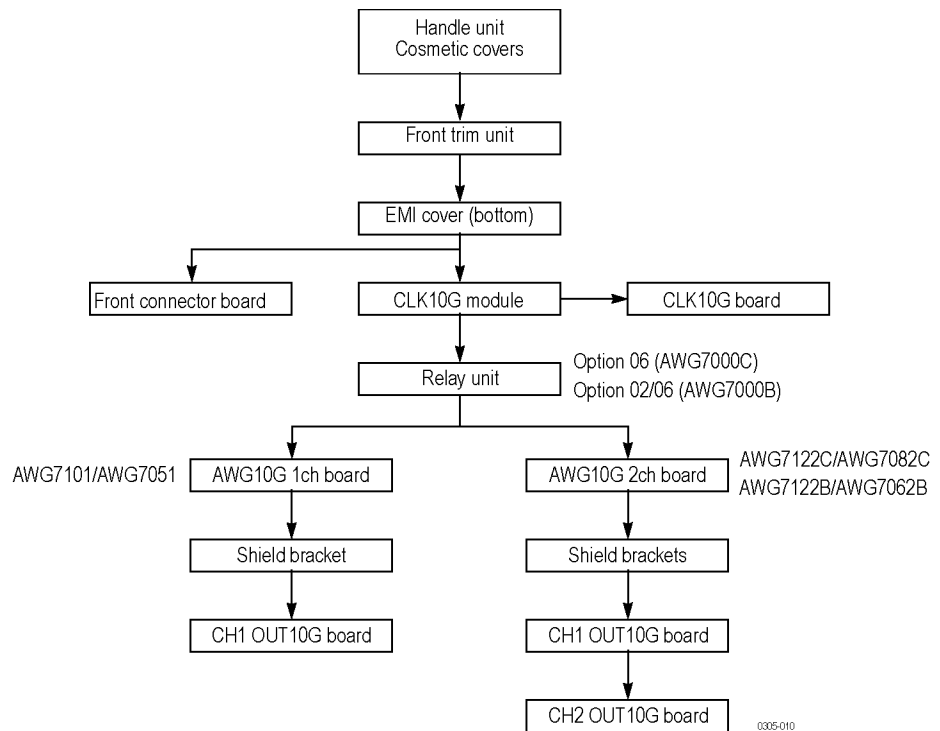

Figure 4-2: Disassembly procedures for internal modules (bottom)

Required Equipment

Most modules in the instrument can be removed with a screwdriver handle mounted with a size T-15, Torx screwdriver tip. All equipment required to remove and reinstall the modules is listed in the following table.

Table 4-3: Tools required for module removal and reinstall

Item #	Name	Description	General Tool #
1.	Screwdriver handle	Accepts Torx-driver bits	620-440
2.	T-15 Torx tip	Torx-driver bit for T-15 size screw heads	640-247
3.	T-10 Torx tip	Torx-driver bit for T-10 size screw heads	
4.	T-20 Torx tip	Torx-driver bit for T-20 size screw heads	
5.	#1 Phillips screwdriver	Screwdriver for removing #1 size Phillips screws	Standard tool
6.	#2 Phillips screwdriver	Screwdriver for removing #2 size Phillips screws	Standard tool

Table 4-3: Tools required for module removal and reinstall (cont.)

Item #	Name	Description	General Tool #
7.	3/16 inch open-end wrench	Used to remove nut posts	Standard tool
8.	Pliers	Pliers modified for use in SMP cable insertion/extraction	003-1895-00
9.	5/16 inch torque wrench (8.0 in-lbs)	Used to remove SMA cables	
10.	Angle-Tip Tweezers	Used to remove the front-panel knob	Standard tool
11.	Wire cutter	Used to remove cable ties	Standard tool

Disconnecting and Connecting the SMP Cable

When you disconnect or connect the SMP cable, use the pliers specified in the required equipment table and keep the connector vertical. If excessive sideways force is applied, the connector is damaged.

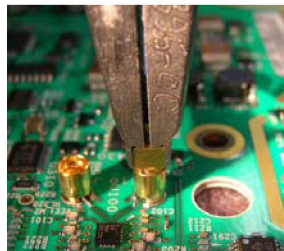

Connect and disconnect straight

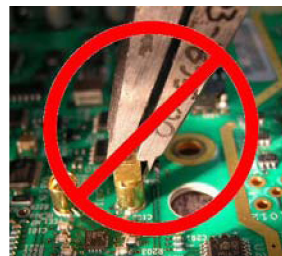

Do not move from side to side.

Figure 4-3: Disconnecting and connecting the SMP cable

Procedures for External Modules

Handle Unit You need a screwdriver with a T-20 Torx tip (items 1 and 4).

Removal. To remove the handle unit, follow these steps: (See Figure 4-4 on page 4-11.)

1. Remove the two screws securing the handle base bracket to the cosmetic cover.
2. Grasp the bracket and handle away from the cosmetic cover.

Installation. To install, reverse this procedure.

Snaps You need a screwdriver with a T-15 Torx tip (items 1 and 2).

Removal. To remove the snaps, follow these steps: (See Figure 4-4 on page 4-11.)

1. Remove the four screws securing the snaps to the cosmetic cover.
2. Lift the snaps away from the cosmetic cover.

Installation. To install, reverse this procedure.

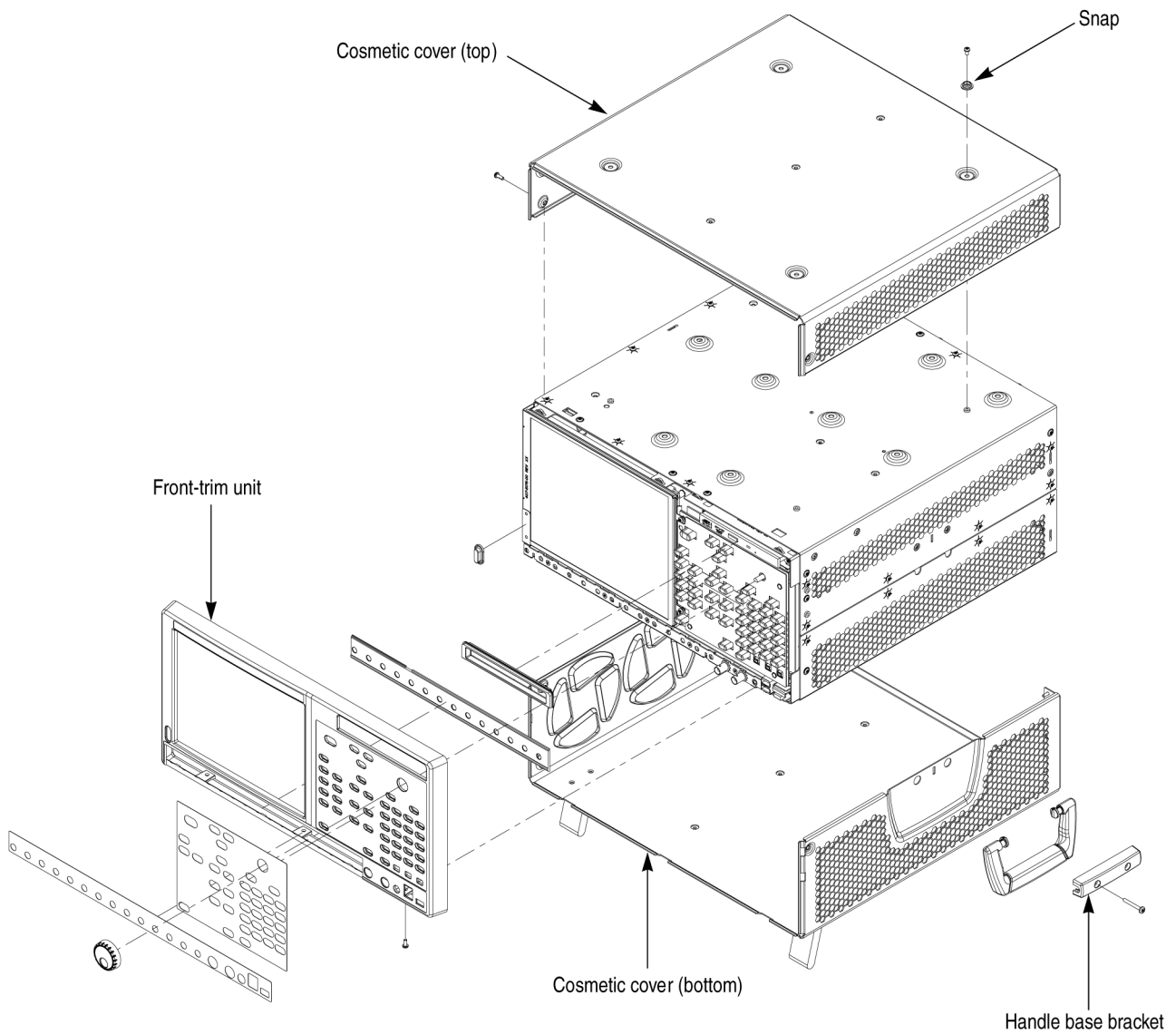

Figure 4-4: Handle, snaps, cosmetic covers, and front-trim unit removal

Cosmetic Cover (Top) You need a screwdriver with a T-15 Torx tip (items 1 and 2).

Removal. To remove the top cosmetic cover, follow these steps: (See Figure 4-4 on page 4-11.)

1. Remove the snaps.
2. Remove the two screws (side) and three screws (top) securing the cosmetic cover to the chassis.
3. Loosen the cover with a detaching tool, such as a flat-blade screwdriver.
4. Tilt the rear side of the cover up, and then pull it off the chassis.

Installation. To install, reverse this procedure.

Cosmetic Cover (Bottom) You need a screwdriver with a T-15 Torx tip (items 1 and 2).

Removal. To remove the bottom cosmetic cover, follow these steps: (See Figure 4-4 on page 4-11.)

1. Remove the handle unit.
2. Orient the instrument so its top is down on the work surface and its rear is facing you.
3. Remove the two screws (side) and three screws (bottom) securing the cosmetic cover to the chassis.
4. Loosen the cover with a detaching tool, such as a flat-blade screwdriver.
5. Tilt the rear side of the cover up, and then pull it off the chassis.

Installation. To install, reverse this procedure.

Front-Trim Unit

You need a screwdriver with a T-15 Torx tip, and angle-tip tweezers (items 1, 2, and 10).

Removal. To remove the front-trim unit, follow these steps: (See Figure 4-4 on page 4-11.)

1. Remove the handle unit, snaps, and cosmetic covers.
2. Orient the instrument so that the rear is on the work surface.
3. Tape the power switch button down so that it will not come off the front trim.
4. Remove the knob by pulling it straight out from the front panel with the angle-tip tweezers.
5. Remove the three screws at the bottom of the front trim.
6. Grasp the bottom side of the front trim, and pull off the bottom side of it by loosening the DVD drive part.
7. The upper part of the chassis has three projections. The front trim fits in these projections. When removing the front trim, grasp its back edge and flex it upward before pulling it forward.

Installation. To install, reverse this procedure.

EMI Covers

You need a screwdriver with a T-15 Torx tip (items 1 and 2).

Removal. To remove the EMI covers, follow these steps: (See Figure 4-5 on page 4-14.)

1. Remove the handle unit, snaps, cosmetic covers, and front-trim unit.
2. Remove the top cover:
 - a. Orient the instrument so that the bottom is on the work surface.
 - b. Remove the 14 screws securing the top EMI cover to the chassis.
 - c. Lift the cover off the chassis.
3. Remove the bottom cover:
 - a. Orient the instrument so that the top is on the work surface.
 - b. Remove the 12 screws securing the bottom EMI cover to the chassis.
 - c. Lift the cover off the chassis.

Installation. To install, reverse this procedure.

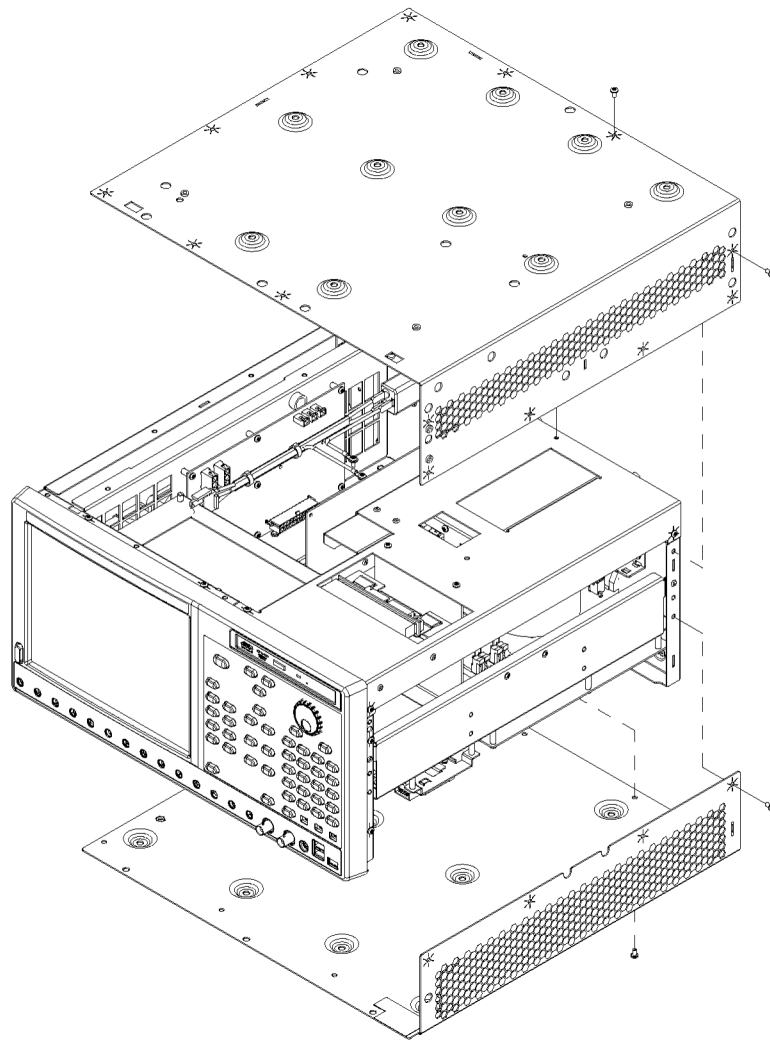

Figure 4-5: EMI cover removal

Hard Disk Assembly

Removal. To remove the removable hard disk assembly, follow these steps:

1. Orient the instrument so that its bottom is down on the work surface and its rear is facing you.
2. Loosen the two thumb screws securing the hard disk assembly to the instrument.
3. Holding the screw heads, pull out the removable hard disk assembly carefully.

Installation. To install, reverse this procedure.



CAUTION. *The hard disk drive is extremely susceptible to static-discharge damage, shock, dust and so on. When you store a removable hard disk assembly, put it into an anti-static plastic bag to protect it.*

Fan Tray Unit

You need a screwdriver with a T-15 Torx tip and a #2 Phillips screwdriver (items 1, 2, and 6).

Removal. To remove the fan tray unit, follow these steps: (See Figure 4-6.)

1. Remove the handle unit, snaps, cosmetic covers, front-trim unit, and EMI covers.
2. Disconnect the fan cables from J300, J302, and J304 on the Power board.
3. Remove the four screws securing the fan tray unit to the chassis.
4. Lift the fan tray unit away from the chassis.
5. Use a #2 Phillips screwdriver to remove the 12 screws securing the fans to the fan bracket.

Install. To install, reverse this procedure.

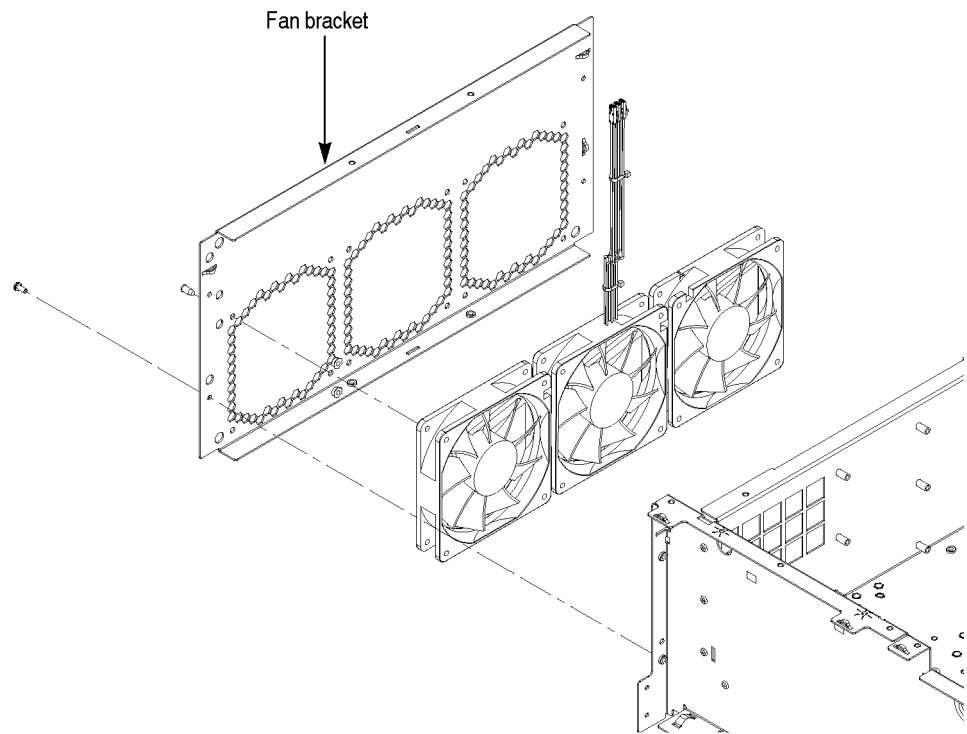

Figure 4-6: Fan tray unit removal

Front-Panel Unit You need a screwdriver with a T-15 Torx tip (items 1 and 2).

Removal. To remove the front-panel unit, follow these steps: (See Figure 4-7 on page 4-18.)

1. Remove the handle unit, snaps, cosmetic covers, front-trim unit, and EMI covers.
2. Orient the instrument so that the rear is on the work surface.
3. Remove the seven screws securing the front-panel bracket to the chassis.
4. Grasp the front-panel assembly and pull it forward.
5. Disconnect the cable from J100 on the LCDA board.
6. Disconnect the cable from J300 on the LCDA board.

Installation. To install, reverse this procedure.

**Front-Panel Assembly
(AWG7000C Series)**

You need a screwdriver with a T-15 Torx tip (items 1 and 2).

Removal. To remove the front-panel assembly, follow these steps: (See Figure 4-7 on page 4-18.)

1. Remove the cosmetic covers, front-trim unit, and EMI covers.
2. Remove the Display Adapter board and Front Panel board:
 - a. Remove the four screws securing the Display Adapter board and Front Panel board to the front-panel bracket.
 - b. Remove the cables from J110, 500, and J200.
 - c. Lift the boards away from the front-panel bracket.
3. Remove the display module:
 - a. Remove the two screws from the touch screen bracket and lift the bracket away.
 - b. Remove the four screws securing the display module (touch screen and LCD) to the front-panel bracket.
 - c. Disconnect the cable from the FSW board.
 - d. Disconnect the cable from J200 on the Display Adapter board.
 - e. Disconnect the cable from J110 on the Display Adapter board.
 - f. Lift the display module away from the front-panel bracket.
4. Disassemble the front-panel assembly components, using the following figure as a guide.

Installation. To install, reverse this procedure.

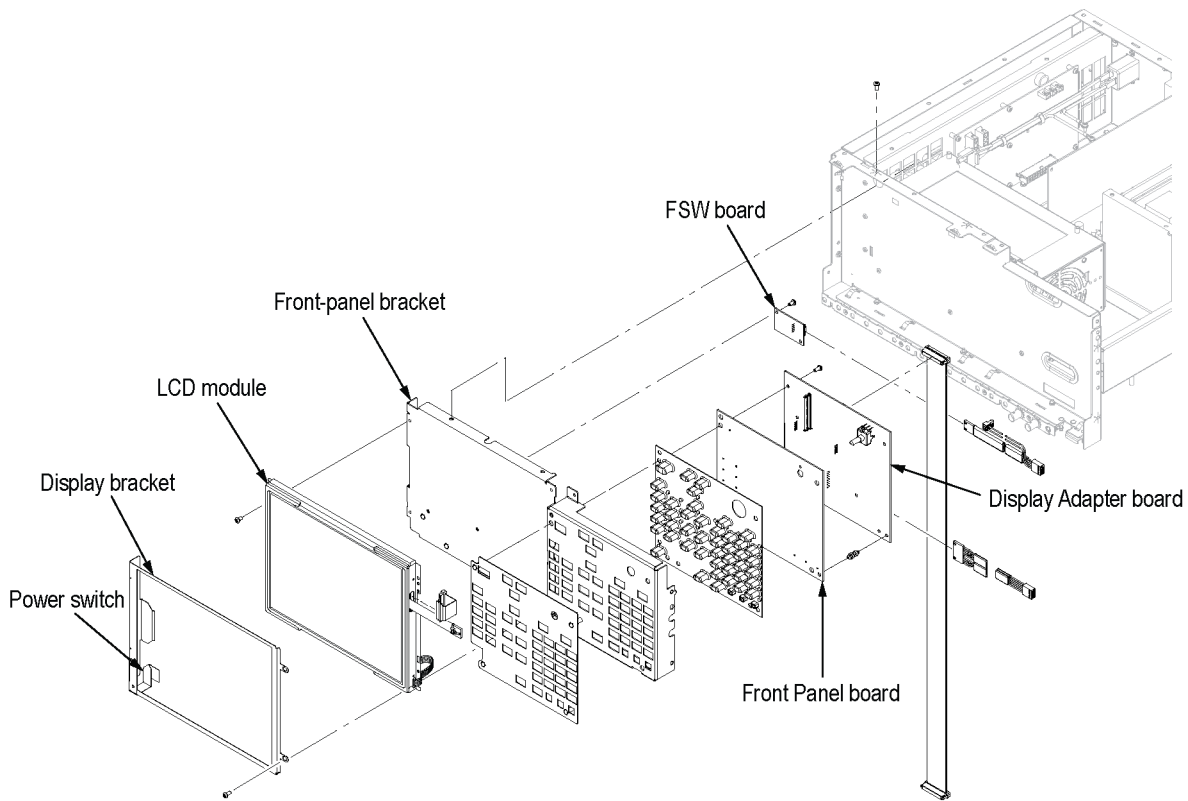

0304-008

Figure 4-7: Disassembly of front-panel assembly (AWG7000C Series)

**Front-Panel Assembly
(AWG7000B Series)**

You need a screwdriver with a T-15 Torx tip (items 1 and 2).

Removal. To remove the front-panel assembly, follow these steps: (See Figure 4-8 on page 4-20.)

1. Remove the cosmetic covers, front-trim unit, and EMI covers.
2. Remove the LCDA board and Front Panel board:
 - a. Remove the four screws securing the LCDA board and Front Panel board to the front-panel bracket.
 - b. Remove the cables from J110, J160, and J200.
 - c. Lift the boards away from the front-panel bracket.

3. Remove the touch screen module:
 - a. Remove the two screws securing the touch screen module to the front-panel bracket.
 - b. Disconnect the cable from J200 on the LCDA board.
 - c. Lift the touch screen module away from the front-panel bracket.
4. Remove the LCD module:
 - a. Remove the four screws securing the LCD module to the front-panel bracket.
 - b. Disconnect the cable from J110 on the LCDA board.
 - c. Disconnect the cable from CN2 on the Inverter board.
 - d. Lift the LCD module away from the front-panel bracket.
5. Disassemble the front-panel assembly components, using the following figure as a guide.

Installation. To install, reverse this procedure.

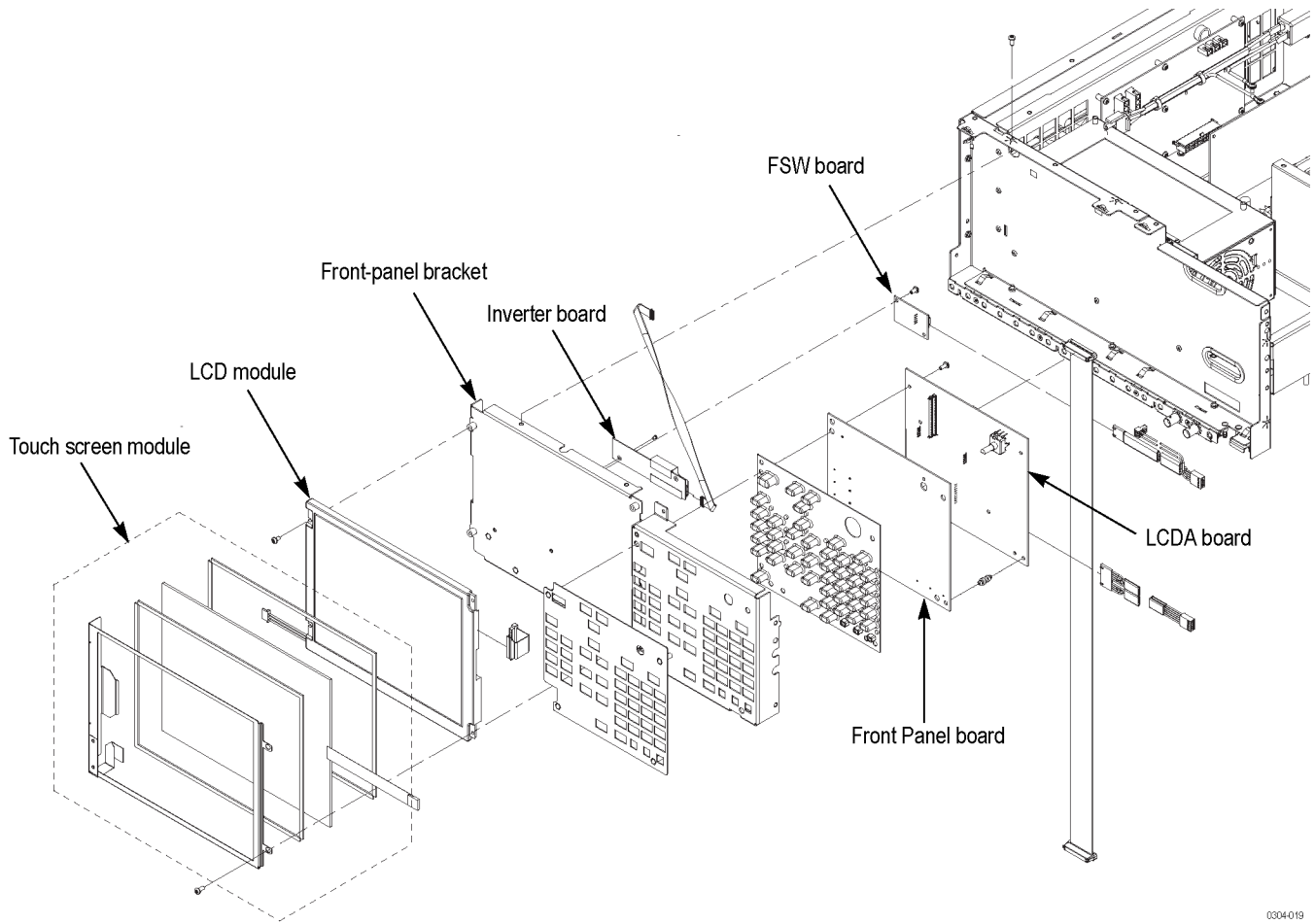

0304-019

Figure 4-8: Disassembly of front-panel assembly (AWG7000B Series)

Procedures for Internal Modules (Upper) (AWG7000C Series)

Drive-Bay Module

You need a screwdriver with a T-15 Torx tip (items 1 and 2).

Removal. To remove the drive-bay module, follow these steps: (See Figure 4-9 on page 4-22.)

1. Remove the handle unit, snaps, cosmetic covers, front-trim unit, EMI covers, and hard disk assembly.
2. Orient the instrument so that the bottom is on the work surface.
3. Remove the eight screws securing the drive-bay module to the chassis.
4. Disconnect the cables from J101 and J104 on the Power board.
5. Disconnect the cables from J5J1 and J7J1 on the Processor board.
6. Lift the drive-bay module away from the chassis.

Installation. To install, reverse this procedure.

DVD-ROM Drive

You need a screwdriver with a T-15 Torx tip and a #1 Phillips screwdriver (items 1, 2, and 5).

Removal. To remove the DVD-ROM drive, follow these steps: (See Figure 4-9 on page 4-22.)

1. Remove the handle unit, snaps, cosmetic covers, front-trim unit, EMI covers, hard disk assembly, and drive-bay module.
2. Remove the two screws securing the DVD-ROM bracket to the drive-bay chassis.
3. Slide the DVD-ROM drive with bracket out from the drive-bay chassis.
4. Remove the four screws securing the DVD-ROM drive to the bracket.

Installation. To install, reverse this procedure.

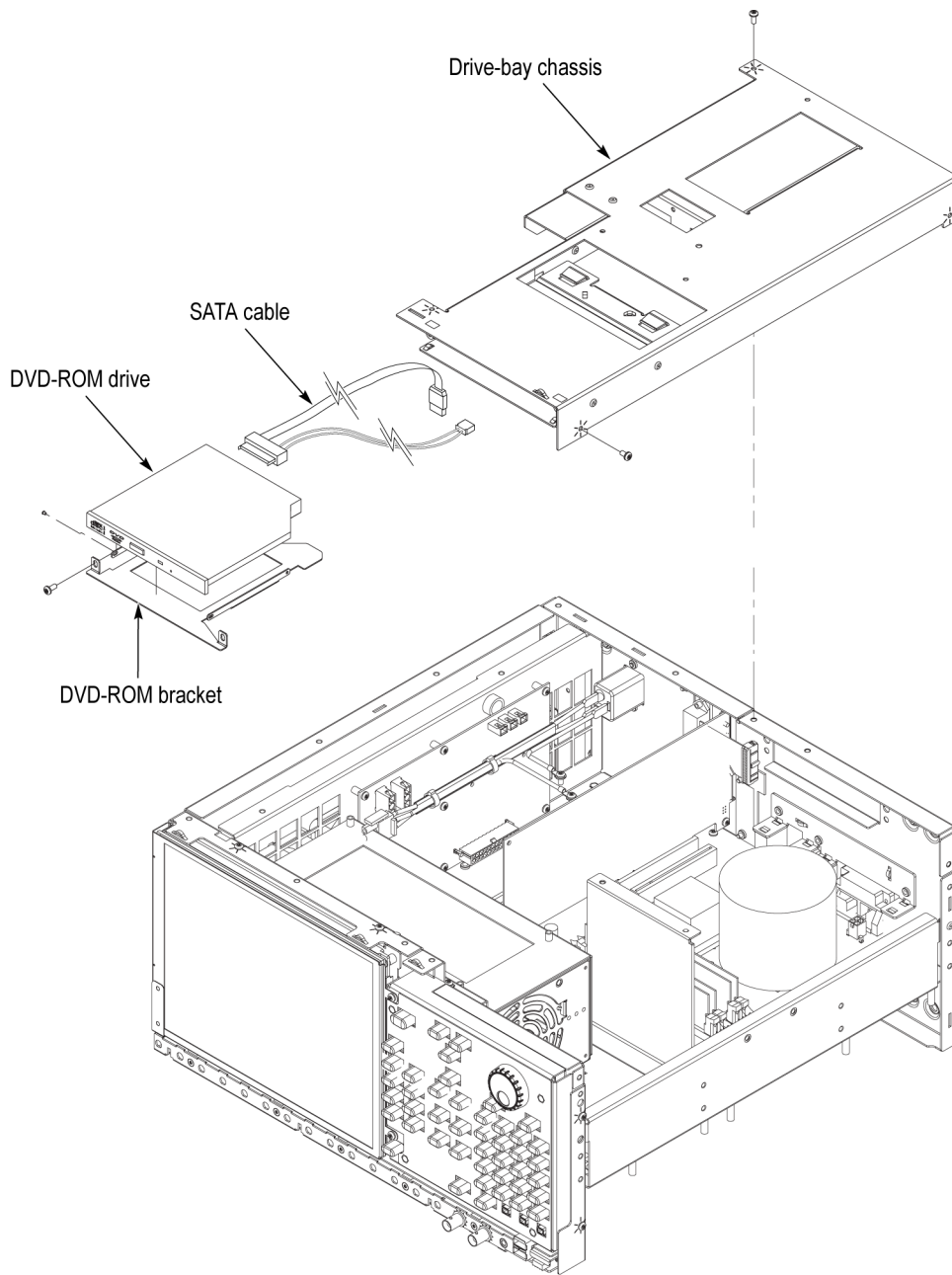

0304-013

Figure 4-9: Drive module removal (AWG7000C Series)

Multi-Input/Output Board

You need a screwdriver with a T-15 Torx tip (items 1 and 2).

Removal. To remove the Multi-Input/Output (MIO) board, follow these steps:
(See Figure 4-15.)

1. Remove the handle unit, snaps, cosmetic covers, front-trim unit, EMI covers, hard disk assembly, and drive-bay module.
2. Orient the instrument so that the bottom is on the work surface and the rear is facing you.
3. Disconnect the cables from J360, J600, J670, and J680 on the MIO board.
4. Remove the six screws securing the MIO board to the chassis.
5. Carefully pull up on the board to loosen it from the Processor board.
6. Lift the circuit board and pull it through the rear of the chassis.
7. Remove the rear bracket and hardware from the circuit board.

Installation. To install, reverse this procedure.

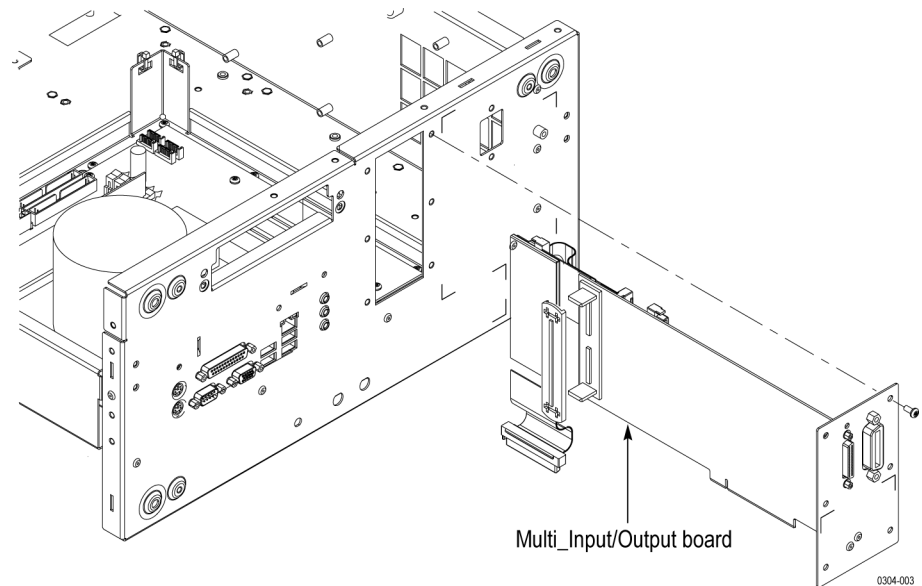

Figure 4-10: Multi-Input/Output board removal (AWG7000C Series)

Processor Module

You need a screwdriver with a T-15 Torx tip and a 3/16 inch open-end wrench (items 1, 2, and 7).

NOTE. *Before you remove the processor module, you need to disconnect the ribbon cable at J1000 from the AWG12G board. (See page 4-45, AWG12G 1 CH Board (AWG7000B Series Only).) (See page 4-46, AWG12G 2 CH Board.)*

Removal. To remove the processor module, follow these steps: (See Figure 4-11 on page 4-25.)

1. Remove the handle unit, snaps, cosmetic covers, front-trim unit, EMI covers, hard disk assembly, drive-bay module, and Multi-Input/Output board.
2. Orient the instrument so that the bottom is on the work surface.
3. Remove the two screws securing the drive-bay bracket to the processor tray.
4. Lift the drive-bay bracket away from the processor tray. (If necessary, remove the ribbon cable through the hole on the drive-bay bracket.)
5. Remove the six mounting posts securing the VIDEO connector, COM 1 connector, and PARALLEL PORT connector to the chassis.
6. Remove the eight screws securing the Processor tray to the chassis.
7. Disconnect these cables:
 - The cable from the Power board at ATX1 and ATX12V1.
 - The cable from the Display Adapter board at USB78.
 - The cable from the Front Connector board at USB56.
 - The cable from the Front Switch board and Multi-Input/Output board at F_PANEL.
 - The cable from the CD/DVD ROM Drive at SATA6.
 - The cable from the hard drive at SATA5.
 - The cable from the eSATA connector at SATA2.
8. Carefully lift up and slide the processor module away from the chassis.

Installation. To install, reverse this procedure.

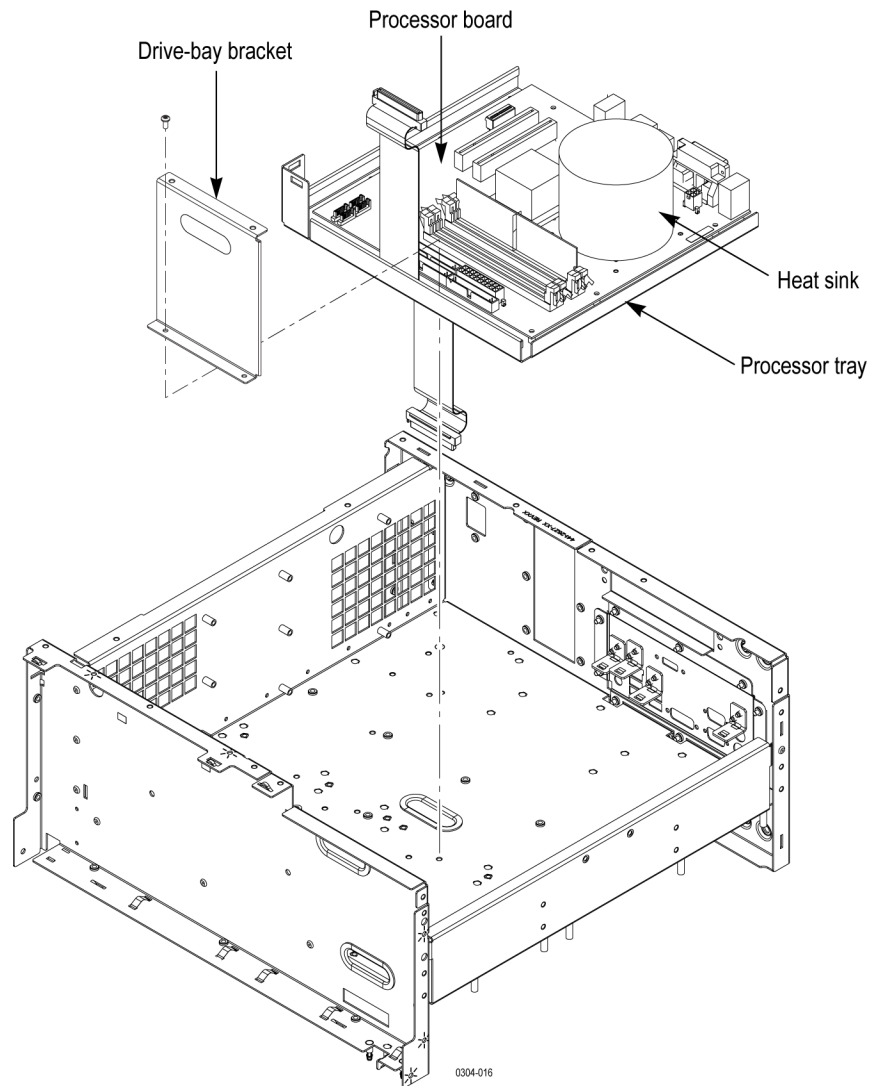

Figure 4-11: Processor module removal (AWG700C Series)

Power Supply You need a screwdriver with a T-15 Torx tip (items 1 and 2).

Removal. To remove the power supply, follow these steps: (See Figure 4-12 on page 4-27.)

1. Remove the handle unit, snaps, cosmetic covers, front-trim unit, EMI covers, hard disk assembly, drive-bay module, and Multi-Input/Output board.
2. Orient the instrument so that the bottom is on the work surface.
3. Remove the six screws securing the power supply bracket to the chassis.
4. Disconnect the cable from J611 on the Power board.
5. Remove the three screws securing the bracket to the power supply.
6. Carefully slide the module to loosen it from the Power board.
7. Lift the power supply up out of the chassis.
8. Lift the bracket up out of the chassis.

Installation. To install, reverse this procedure.

RFI Filter You need a screwdriver with a T-15 Torx tip (items 1 and 2).

Removal. To remove the RFI filter, follow these steps: (See Figure 4-12 on page 4-27.)

1. Remove the handle unit, snaps, cosmetic covers, and EMI covers.
2. Orient the instrument so that the bottom is on the work surface.
3. Disconnect the cable from J600 on the Power board.
4. Remove the two screws securing the ground leads to the chassis.
5. Remove the two screws securing the RFI filter to the chassis.
6. Pull the RFI filter away from the chassis.

Installation. To install, reverse this procedure.

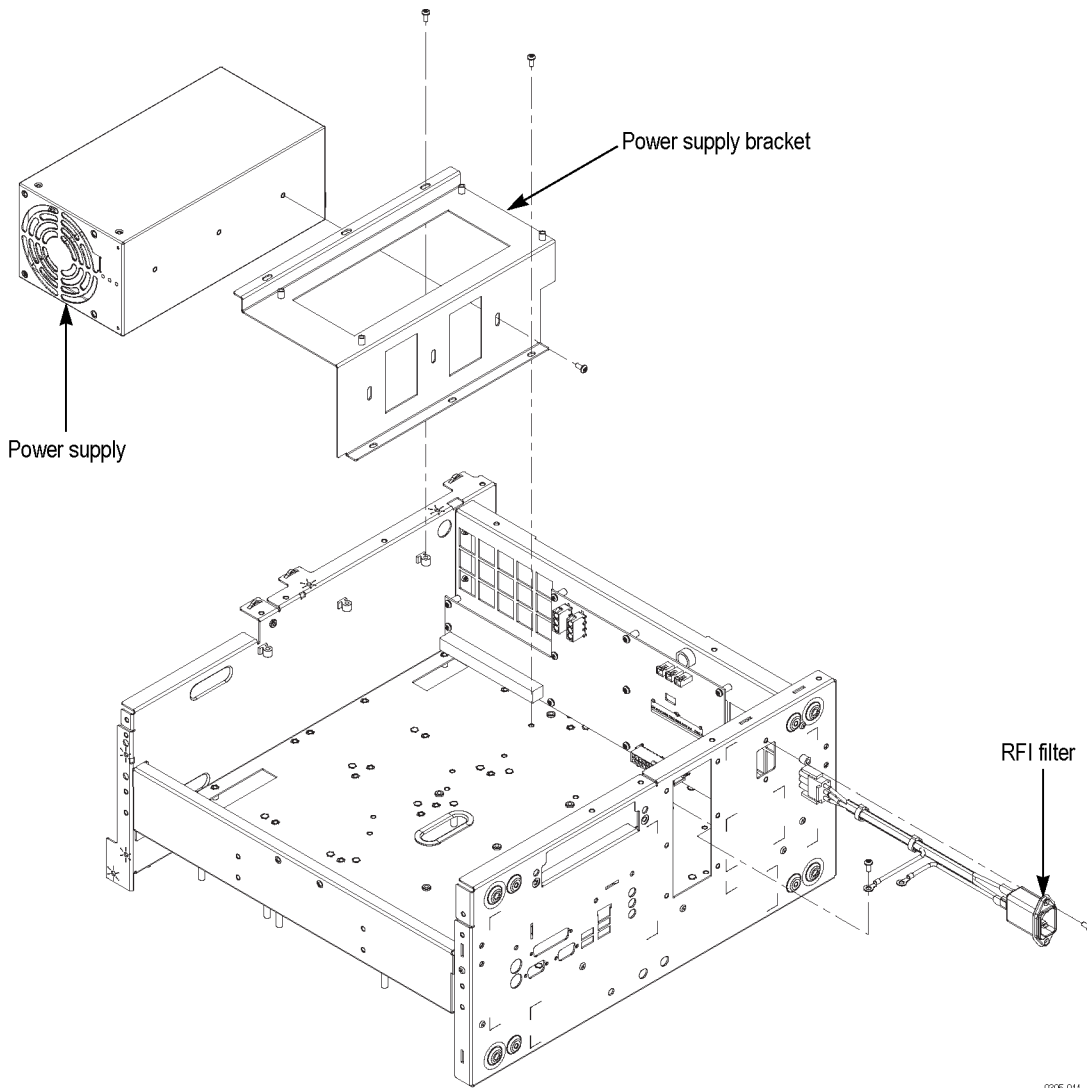

Figure 4-12: Power Supply and RFI filter removal (AWG7000C Series)

Power Board You need a screwdriver with a T-15 Torx tip (items 1 and 2).

Removal. To remove the Power board, follow these steps: (See Figure 4-13 on page 4-28.)

1. Remove the handle unit, snaps, cosmetic covers, front-trim unit, EMI covers, hard disk assembly, drive-bay module, power supply, Multi-Input/Output board, and Processor board.
2. Orient the instrument so that the bottom is on the work surface.
3. Disconnect the cables from J102, J103, J120, J300, J302, J304, J600, and J611 on the Power board.
4. Remove the 10 screws securing the Power board to the chassis.
5. Lift the board away from the chassis.

Installation. To install, reverse this procedure.

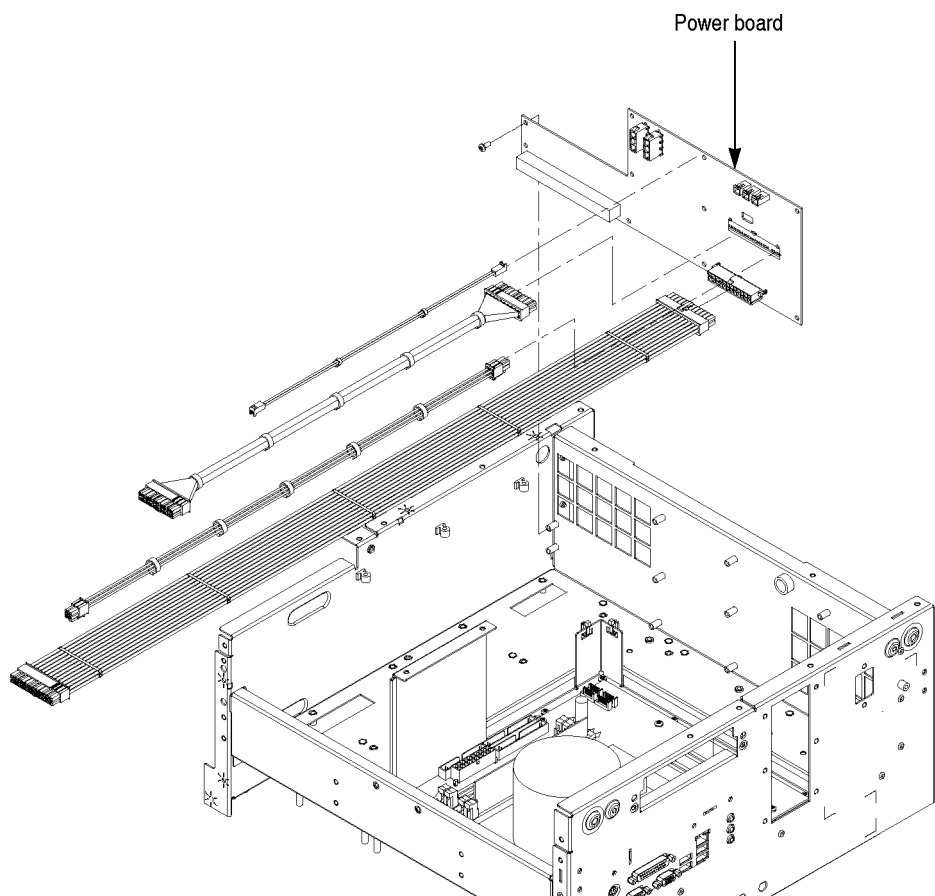

Figure 4-13: Power board removal (AWG7000C Series)

Procedures for Internal Modules (Upper) (AWG7000B Series)

Drive-Bay Module

You need a screwdriver with a T-15 Torx tip (items 1 and 2).

Removal. To remove the drive-bay module, follow these steps: (See Figure 4-14 on page 4-30.)

1. Remove the handle unit, snaps, cosmetic covers, front-trim unit, EMI covers, MIO board enforcement bracket, and hard disk assembly.
2. Orient the instrument so that the bottom is on the work surface.
3. Remove the eight screws securing the drive-bay module to the chassis.
4. Disconnect the cables from J101 and J104 on the Power board.
5. Disconnect the cables from J5J1 and J7J1 on the Processor board.
6. Lift the drive-bay module away from the chassis.

Installation. To install, reverse this procedure.

DVD-ROM Drive

You need a screwdriver with a T-15 Torx tip and a #1 Phillips screwdriver (items 1, 2, and 5).

Removal. To remove the DVD-ROM drive, follow these steps: (See Figure 4-14 on page 4-30.)

1. Remove the handle unit, snaps, cosmetic covers, front-trim unit, EMI covers, MIO board enforcement bracket, hard disk assembly, and drive-bay module.
2. Remove the two screws securing the DVD-ROM bracket to the drive-bay chassis.
3. Slide the DVD-ROM drive with bracket out from the drive-bay chassis.
4. Remove the four screws securing the DVD-ROM drive to the bracket.

Installation. To install, reverse this procedure.

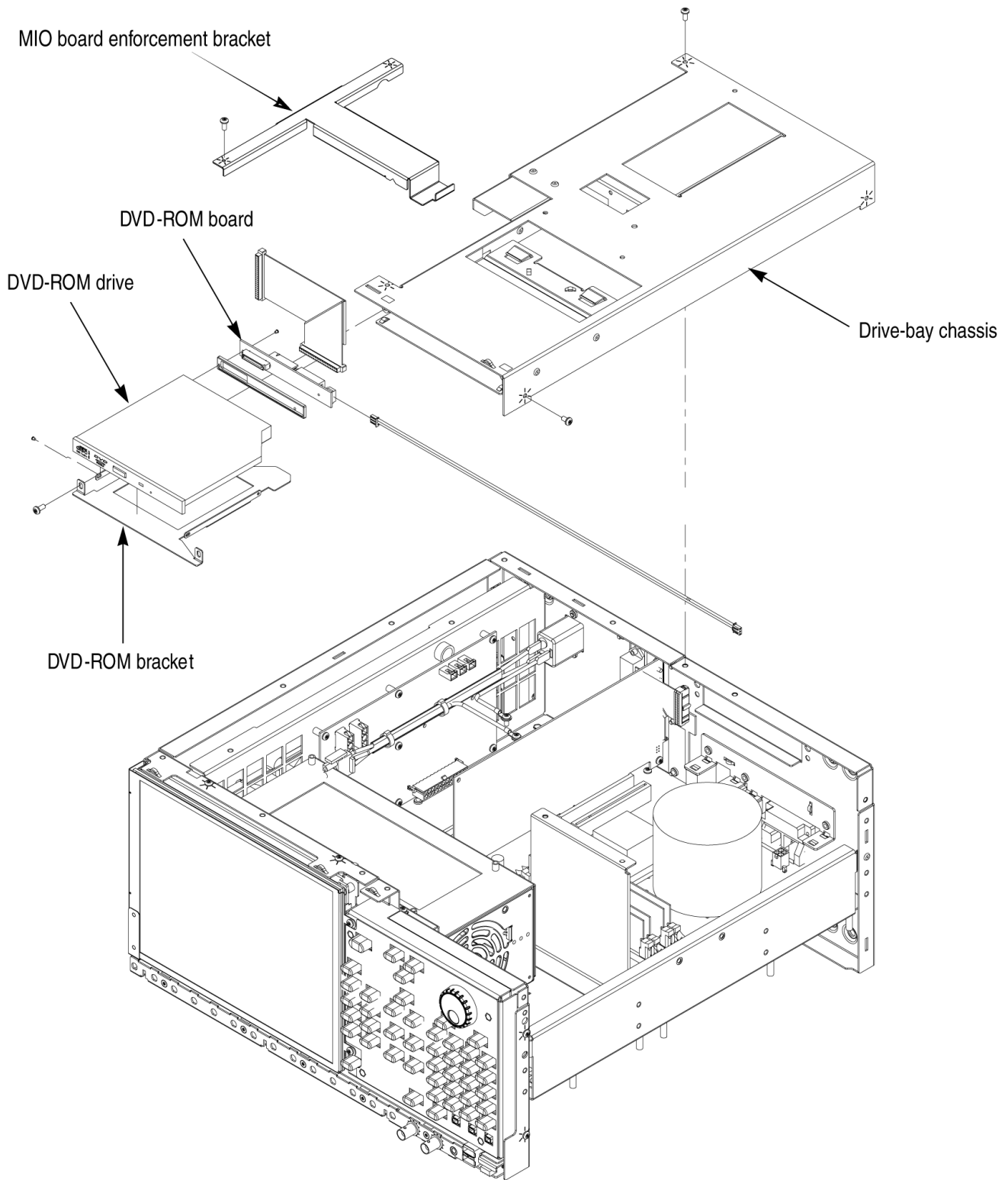

Figure 4-14: Drive module removal (AWG7000B Series)

DVD-ROM Board You need a #1 Phillips screwdriver (item 5).

Removal. To remove the DVD-ROM board, follow these steps: (See Figure 4-14 on page 4-30.)

1. Remove the handle unit, snaps, cosmetic cover, front-trim unit, EMI covers, MIO board enforcement bracket, hard disk assembly, and drive-bay module.
2. Remove the two screws securing the DVD-ROM board to the DVD-ROM drive.
3. Disconnect the cable from J1 on the DVD-ROM board.
4. Disconnect the interface cable on the DVD-ROM board.
5. Lift the board away from the DVD-ROM drive.

Installation. To install, reverse this procedure.

**Multi-Input/Output Board
(Serial Numbers B010000
to B019999)**

You need a screwdriver with a T-15 Torx tip (items 1 and 2).

Removal. To remove the Multi-Input/Output board, follow these steps: (See Figure 4-15 on page 4-32.)

1. Remove the handle unit, snaps, cosmetic covers, front-trim unit, EMI covers, MIO board enforcement bracket, hard disk assembly, and drive-bay module.
2. Orient the instrument so that the bottom is on the work surface and the rear is facing you.
3. Disconnect the cables from J360, J670, J680, and J681 on the Multi-Input/Output board.
4. Remove the screws securing the Multi-Input/Output board to the chassis.
5. Carefully pull up on the board to loosen it from the Processor board.
6. Lift the circuit board and pull it through the rear of the chassis.
7. Remove the rear bracket and hardware from the circuit board.

Installation. To install, reverse this procedure.

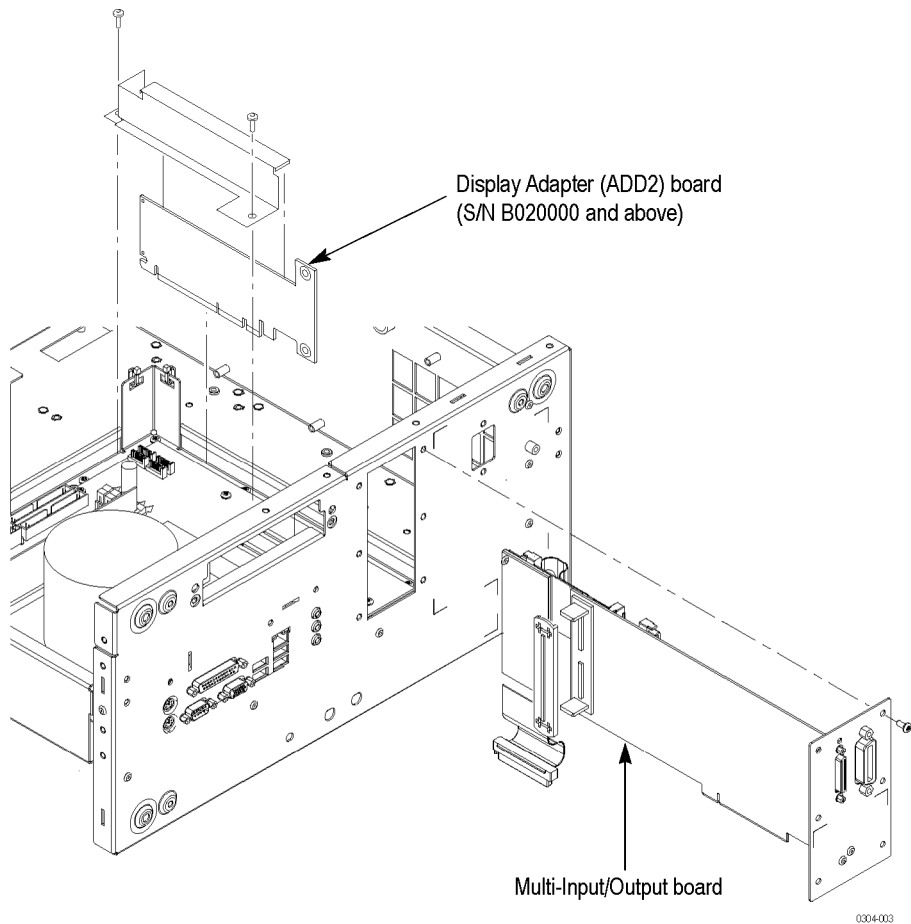

Figure 4-15: Multi-Input/Output and Display Adapter board removal (AWG7000B Series)

**Multi-Input/Output Board
(Serial Numbers B020000
and Higher)**

You need a screwdriver with a T-15 Torx tip (items 1 and 2).

Removal. To remove the Multi-Input/Output board, follow these steps: (See Figure 4-15.)

1. Remove the handle unit, snaps, cosmetic covers, front-trim unit, EMI covers, MIO board enforcement bracket, hard disk assembly, and drive-bay module.
2. Orient the instrument so that the bottom is on the work surface and the rear is facing you.
3. Disconnect the cables from J360, J600, J610, and J680 on the Multi-Input/Output board.
4. Remove the screws securing the Multi-Input/Output board to the chassis.
5. Carefully pull up on the board to loosen it from the Processor board.

6. Lift the circuit board and pull it through the rear of the chassis.
7. Remove the rear bracket and hardware from the circuit board.

Installation. To install, reverse this procedure.

**Display Adapter (Serial
Numbers B020000 and
Higher)**

You need a screwdriver with a T-15 Torx tip (items 1 and 2).

Removal. To remove the Display Adapter board (ADD2 board), follow these steps: (See Figure 4-15 on page 4-32.)

1. Remove the handle unit, snaps, cosmetic covers, front-trim unit, EMI covers, MIO board enforcement bracket, hard disk assembly, and drive-bay module.
2. Orient the instrument so that the bottom is on the work surface and the rear is facing you.
3. Remove the two T-15 screws from the support bracket on the ADD2 board.
4. Disconnect the two cables from the ADD2 board.
5. Carefully pull up on the board to loosen it from the Processor board.
6. Lift the circuit board out of the chassis.

Installation. To install, reverse this procedure.

Processor Module You need a screwdriver with a T-15 Torx tip and a 3/16 inch open-end wrench (items 1, 2, and 7).

NOTE. *Before you remove the processor module, you need to disconnect the ribbon cable at J1000 from the AWG12G board. (See page 4-45, AWG12G 1 CH Board (AWG7000B Series Only).) (See page 4-46, AWG12G 2 CH Board.)*

Removal. To remove the processor module, follow these steps: (See Figure 4-16 on page 4-35.)

1. Remove the handle unit, snaps, cosmetic covers, front-trim unit, EMI covers, MIO board enforcement bracket, hard disk assembly, drive-bay module, and Multi-Input/Output board.
2. Orient the instrument so that the bottom is on the work surface.
3. Remove the two screws securing the drive-bay bracket to the processor tray.
4. Lift the drive-bay bracket away from the processor tray.
5. Remove the three screws securing the connector bracket to the rear panel.
6. Lift the connector bracket away from the rear panel.
7. Remove the six mounting posts securing the VIDEO connector, COM 1 connector, and PARALLEL PORT connector to the chassis.
8. Remove the eight screws securing the Processor tray to the chassis.
9. Disconnect these cables:
 - The cable from the Power board at J2A1, J2A2, and J2J1.
 - The cable from the LCDA board at J8H1.
 - The cable from the Front Connector board at J8G2.
 - The cable from the Front Switch board and Multi-Input/Output board at J8J3.
10. Carefully lift up and slide the processor module away from the chassis.

Installation. To install, reverse this procedure.

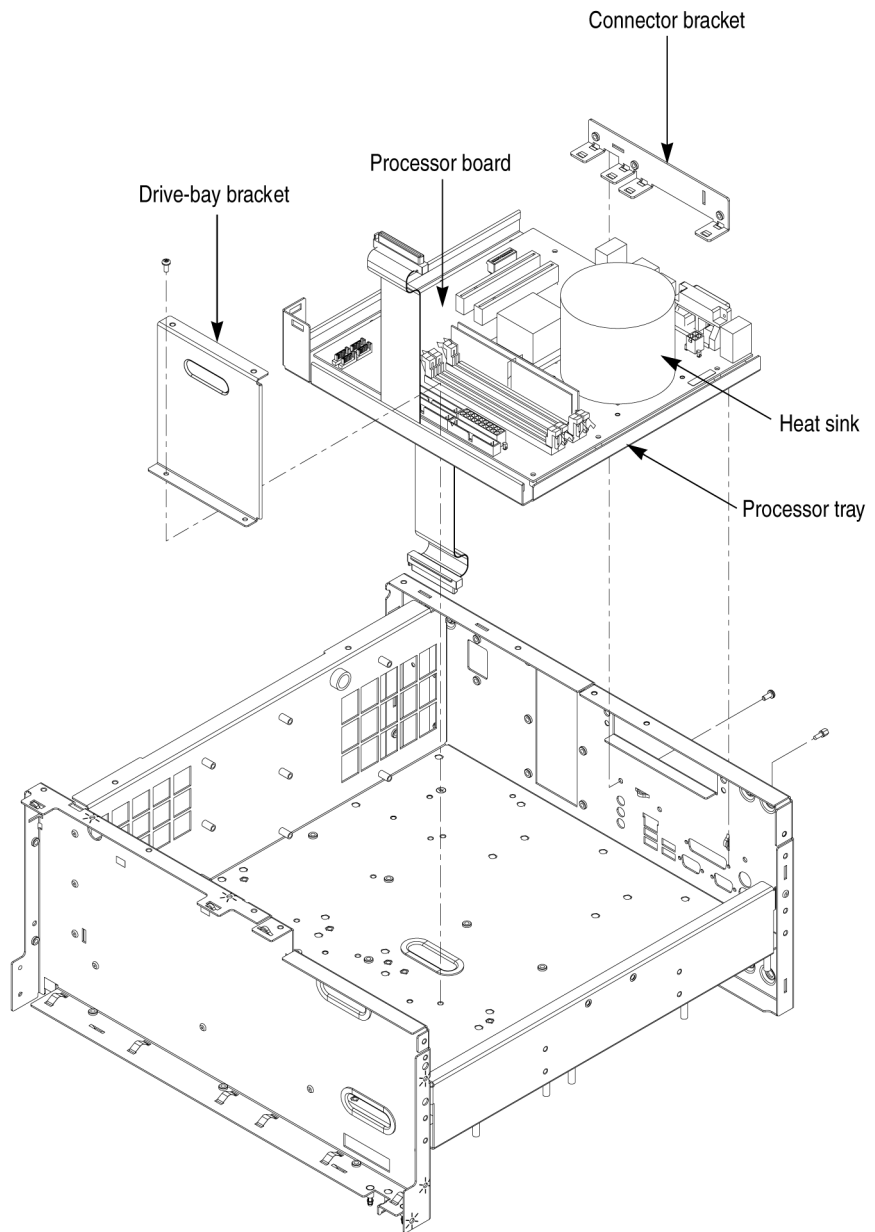

Figure 4-16: Processor module removal (AWG7000B Series)

Power Supply You need a screwdriver with a T-15 Torx tip (items 1 and 2).

Removal. To remove the power supply, follow these steps: (See Figure 4-17 on page 4-37.)

1. Remove the handle unit, snaps, cosmetic covers, front-trim unit, EMI covers, MIO board enforcement bracket, hard disk assembly, drive-bay module, and Multi-Input/Output board.
2. Orient the instrument so that the bottom is on the work surface.
3. Remove the four screws securing the power supply support bracket.
4. Remove the power supply support bracket from the power supply bracket.
5. Remove the six screws securing the power supply bracket to the chassis.
6. Disconnect the cable from J611 on the Power board.
7. Remove the three screws securing the bracket to the power supply.
8. Carefully slide the module to loosen it from the Power board.
9. Lift the power supply up out of the chassis.
10. Lift the bracket up out of the chassis.

Installation. To install, reverse this procedure.

RFI Filter You need a screwdriver with a T-15 Torx tip (items 1 and 2).

Removal. To remove the RFI filter, follow these steps: (See Figure 4-17 on page 4-37.)

1. Remove the handle unit, snaps, cosmetic covers, and EMI covers.
2. Orient the instrument so that the bottom is on the work surface.
3. Disconnect the cable from J600 on the Power board.
4. Remove the two screws securing the ground leads to the chassis.
5. Remove the two screws securing the RFI filter to the chassis.
6. Pull the RFI filter away from the chassis.

Installation. To install, reverse this procedure.

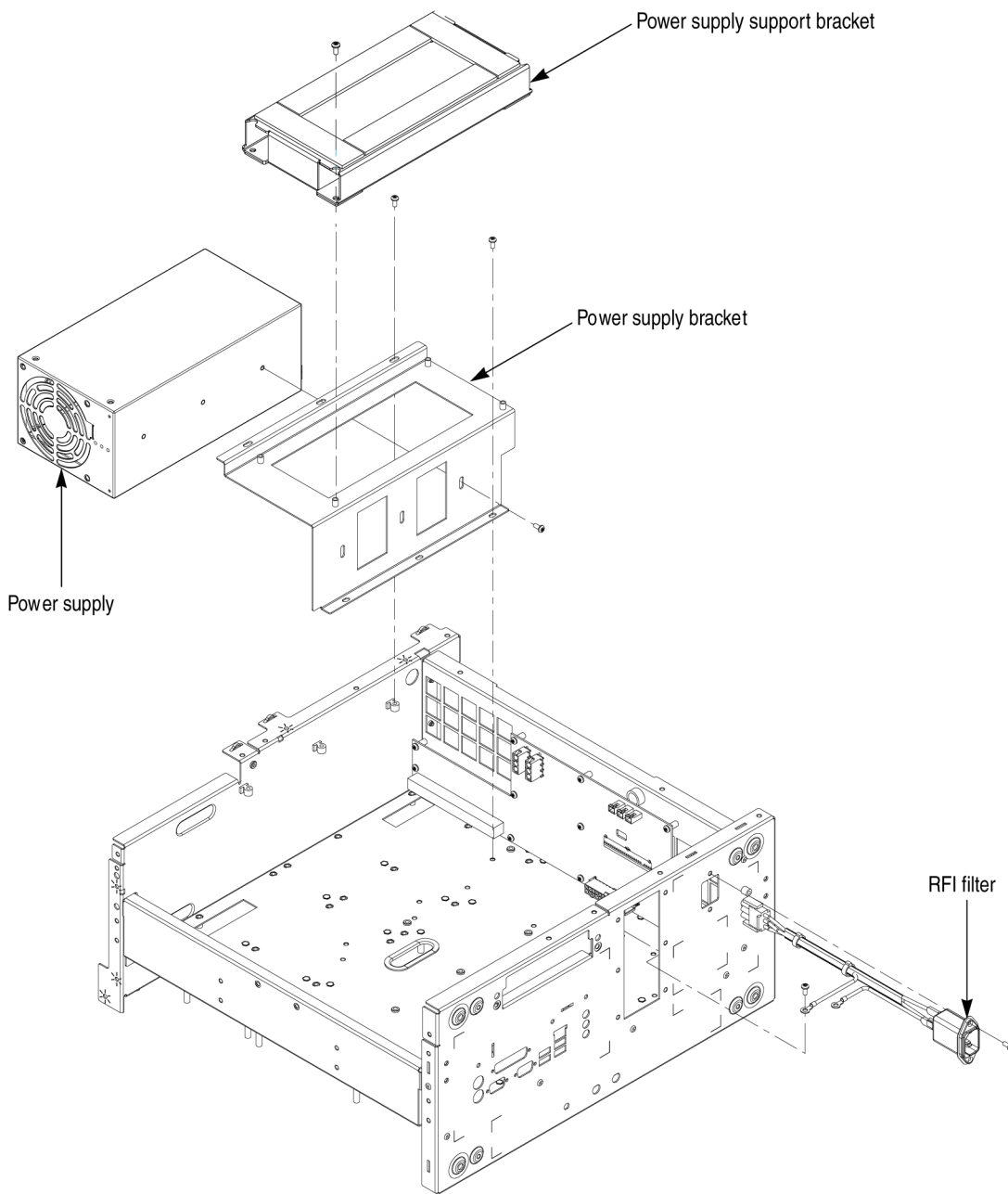

Figure 4-17: Power Supply and RFI filter removal (AWG7000B Series)

Power Board You need a screwdriver with a T-15 Torx tip (items 1 and 2).

Removal. To remove the Power board, follow these steps: (See Figure 4-18 on page 4-38.)

1. Remove the handle unit, snaps, cosmetic covers, front-trim unit, EMI covers, MIO board enforcement bracket, hard disk assembly, drive-bay module, power supply, Multi-Input/Output board, and Processor board.
2. Orient the instrument so that the bottom is on the work surface.
3. Disconnect the cables from J102, J103, J120, J300, J302, J304, J600, and J611 on the Power board.
4. Remove the 10 screws securing the Power board to the chassis.
5. Lift the board away from the chassis.

Installation. To install, reverse this procedure.

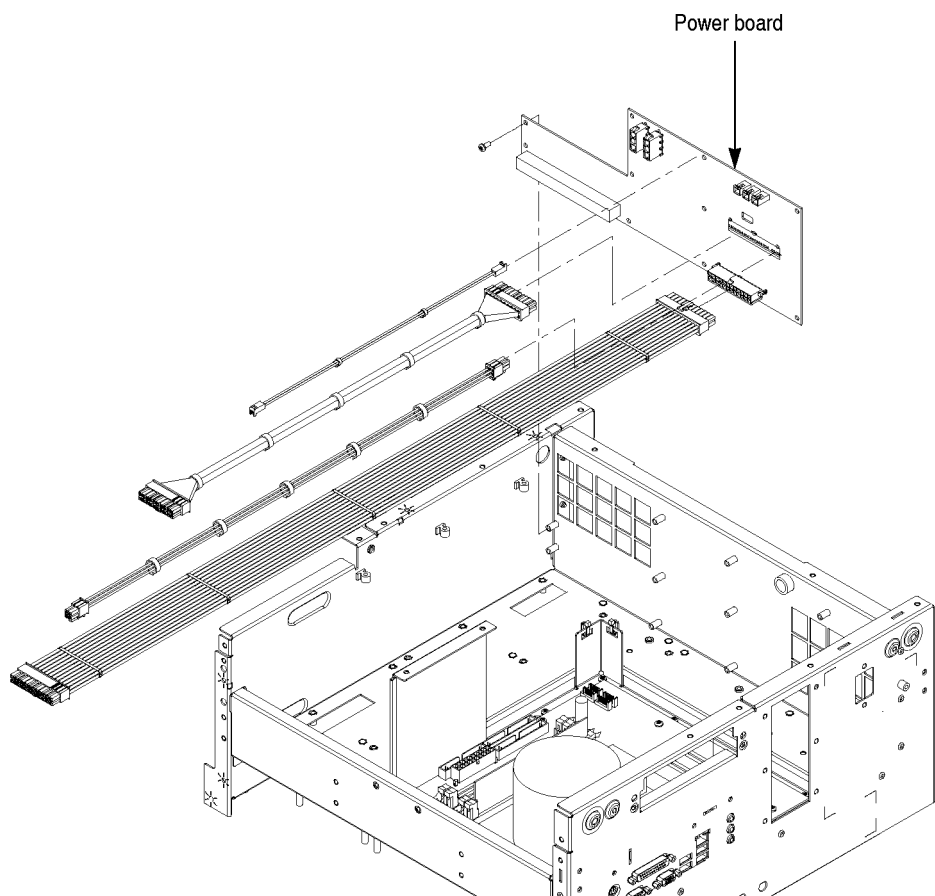

Figure 4-18: Power board removal (AWG7000B Series)

Procedures for Internal Modules (Lower)

Front Connector Board You need a screwdriver with a T-15 Torx tip (items 1 and 2).

Removal. To remove the Front Connector board, follow these steps: (See Figure 4-19 on page 4-40.)

1. Remove the handle unit, snaps, cosmetic covers, front-trim unit, and EMI covers.
2. Orient the instrument so that the top is on the work surface.
3. Disconnect the cables from J100 and J200 on the Front Connector board.
4. Remove the screw securing the Front Connector board to the chassis.
5. Grasp the board and pull it gently away from the chassis.

Installation. To install, reverse this procedure.

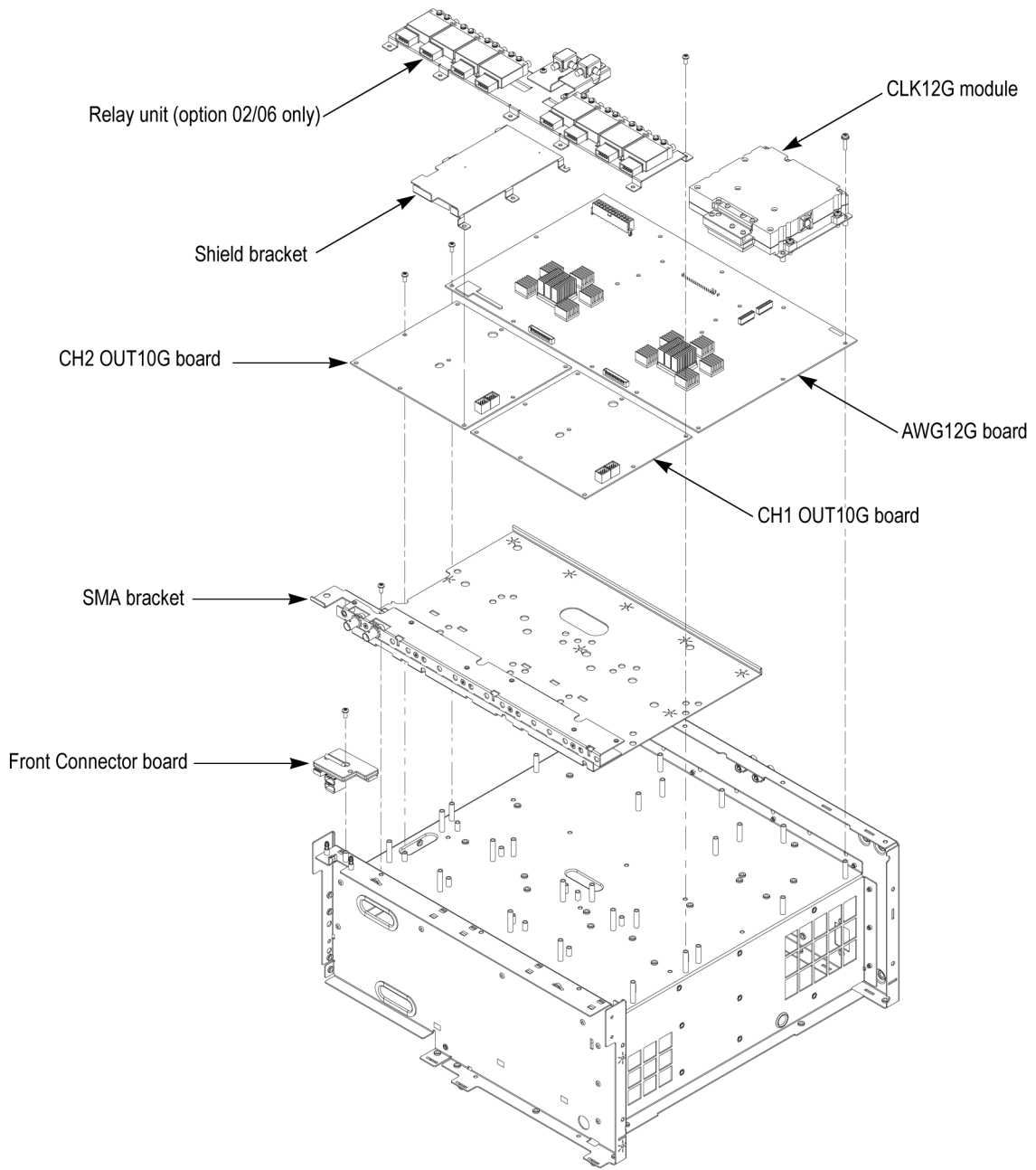

Figure 4-19: Front Connector board, CLK12G module, relay unit, and AWG12G board removal

CLK12G Module

You need a screwdriver with a T-15 Torx tip, pliers, and a 5/16 inch torque wrench (items 1, 2, 8, and 9).

Removal. To remove the CLK12G module, follow these steps: (See Figure 4-19 on page 4-40.)

1. Remove the handle unit, snaps, cosmetic covers, front-trim unit, and EMI covers.
2. Orient the instrument so that the top is on the work surface.
3. Disconnect the cable from J150A (and J150B for 2 channel models) on the AWG12G board.
4. Disconnect the cables from the 10 MHz Reference Output connector and the Reference Clock Input connector.
5. Use a 5/16 inch torque wrench to remove the External Clock Input connector from the rear panel.
6. Remove the four screws securing the CLK12G module to the chassis.
7. Carefully pull up on the module to loosen it from the AWG board.
8. Lift the module away from the chassis.

Installation. To install, reverse this procedure.

CLK12G Board

You need a #1 Phillips screwdriver and a 5/16 inch torque wrench (items 5 and 9).

Removal. To remove the CLK12G board, follow these steps: (See Figure 4-20 on page 4-42.)

1. Remove the five screws securing the shield cover to the top shield case.
2. Lift the shield cover away from the top shield case.
3. Disconnect the cables from J3320 and J3350 (and J3351 for 2 channel models) on the CLK12G board.
4. Use a 5/16 inch torque wrench to remove the two SMA cables from J3110 and J3120 on the CLK12G board.
5. Remove the 10 screws securing the top shield case to the bottom shield case.
6. Lift the top shield case away from the bottom shield case.
7. Lift the CLK12G board away from the bottom shield case.

Installation. To install, reverse this procedure.

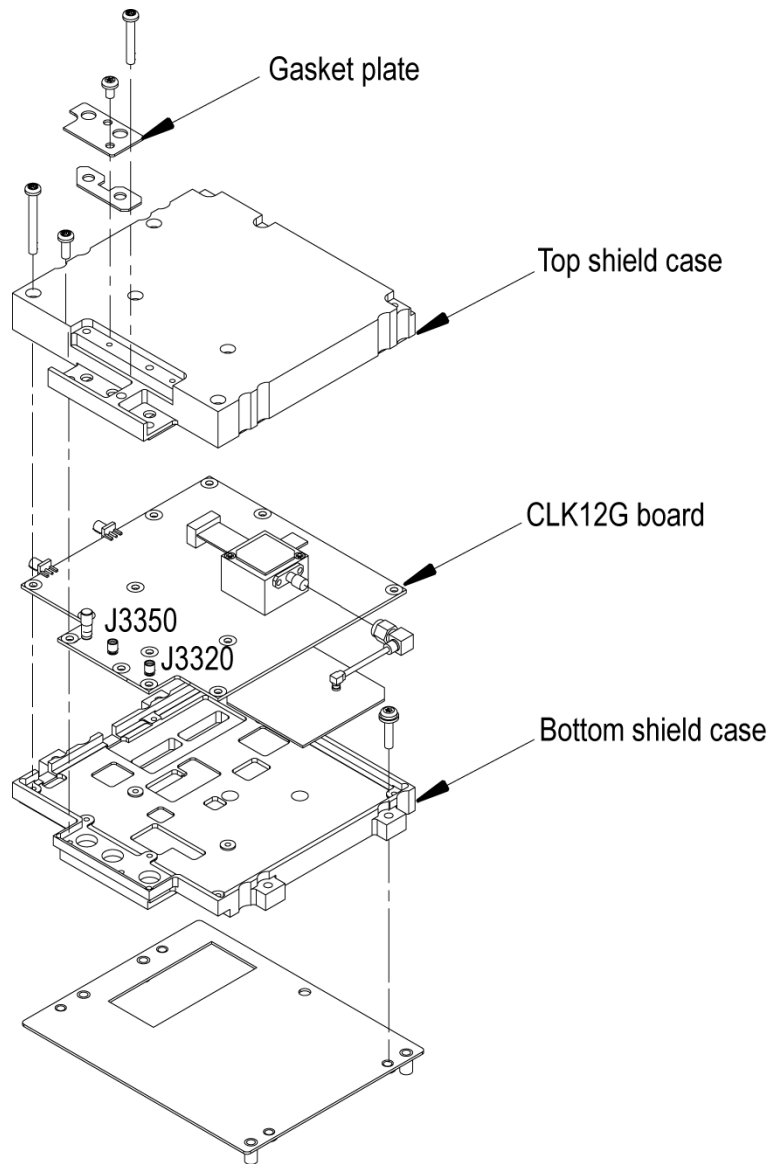

Figure 4-20: Disassembly of the CLK12G module

**Relay Unit (for Option 02)
(AWG7000B Series Only)**

You need a screwdriver with a T-15 Torx tip and a 5/16 inch torque wrench (items 1, 2, and 9).

Removal. To remove the relay unit, follow these steps: (See Figure 4-19 on page 4-40.)

1. Remove the handle unit, snaps, cosmetic covers, front-trim unit, and EMI covers.
2. Orient the instrument so that the top is on the work surface.
3. Use a 5/16 inch torque wrench to remove the six SMA cables (or 12 SMA cables for 2 channel models) from the relay units.
4. Disconnect the cable (or two cables for 2 channel models) from the relay units.
5. Remove the 10 screws securing the relay unit to the chassis.
6. Lift the relay unit away from the chassis.

Installation. To install, reverse this procedure. (See Figure 4-21.)

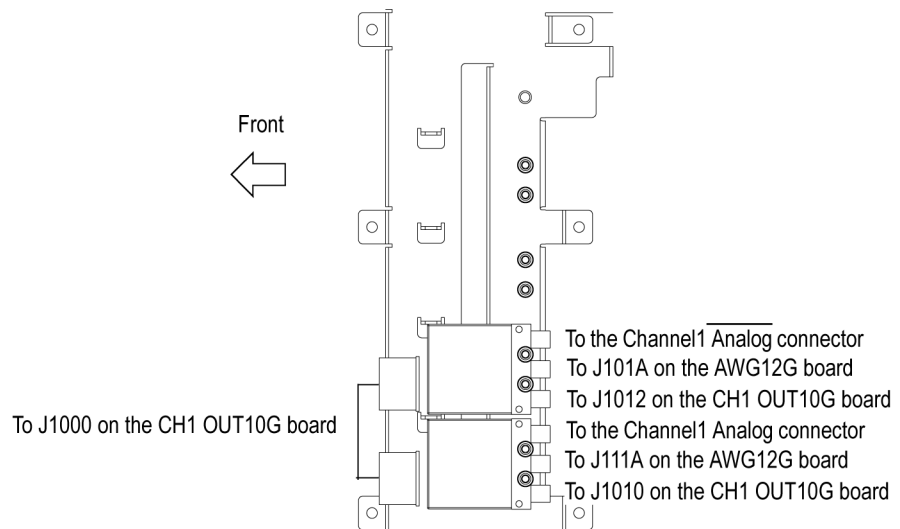

Figure 4-21: Relay unit cable connection for option 02

Relay Unit (for Option 06)

You need a screwdriver with a T-15 Torx tip and a 5/16 inch torque wrench (items 1, 2, and 9).

Removal. To remove the relay unit, follow these steps: (See Figure 4-19 on page 4-40.)

1. Remove the handle unit, snaps, cosmetic covers, front-trim unit, EMI covers.
2. Orient the instrument so that the top is on the work surface.

3. Use a 5/16 inch torque wrench to remove the 14 SMA cables from the relay units.
4. Disconnect the four cables from the relay units.
5. Remove the 10 screws securing the relay unit to the chassis.
6. Lift the relay unit away from the chassis.

Installation. To install, reverse this procedure. (See Figure 4-23.)

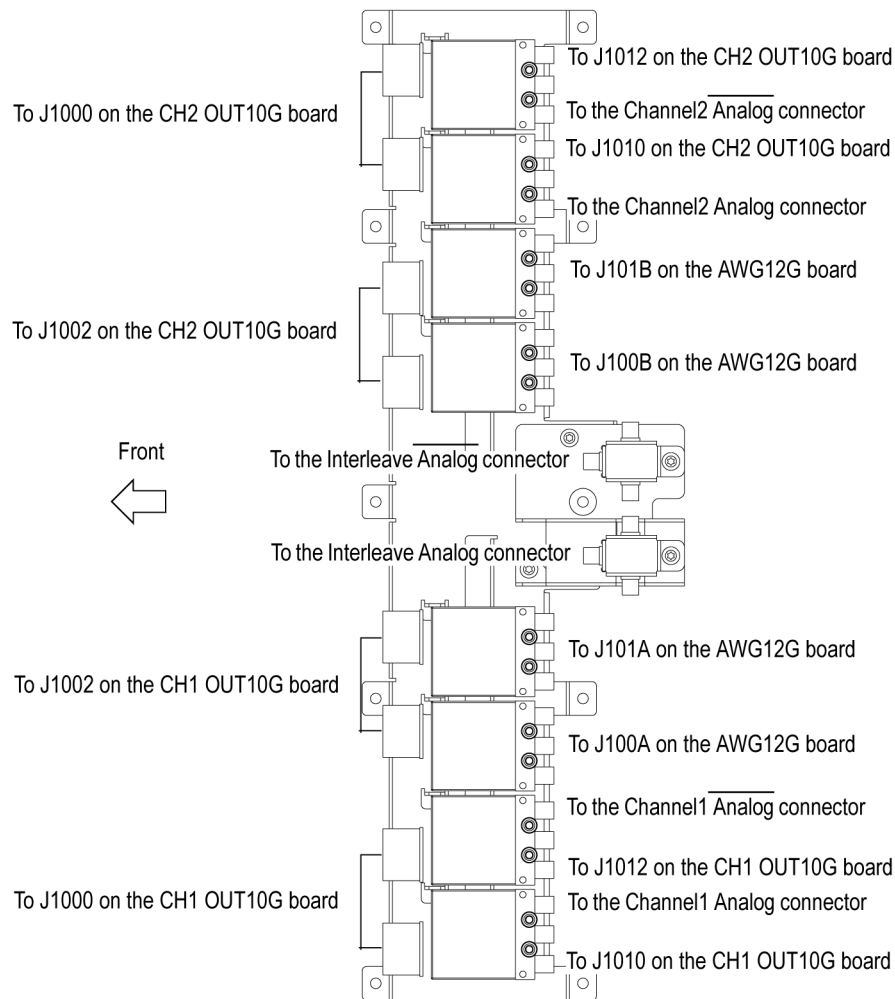

Figure 4-22: Relay unit cable connection for option 06

**AWG12G 1 CH Board
(AWG7000B Series Only)**

You need a screwdriver with a T-15 Torx tip and pliers (items 1, 2, and 8).

Removal. To remove the AWG12G 1 channel board, follow these steps: (See Figure 4-19 on page 4-40.)

1. Remove the handle unit, snaps, cosmetic covers, front-trim unit, EMI covers, CLK12G module, and relay unit (for Option 02).
2. Orient the instrument so that the top is on the work surface.
3. Use a wire cutter to remove the two cable ties.

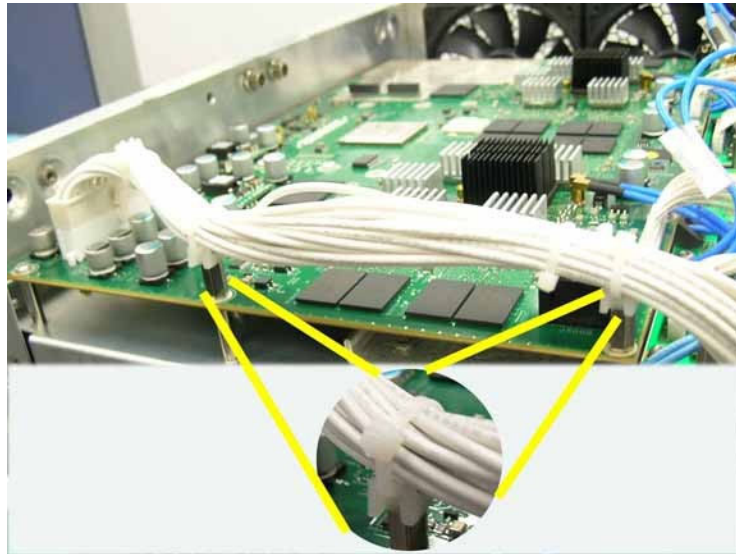

Figure 4-23: Cable ties

4. Remove the two screws, and then remove the tie mount clips.

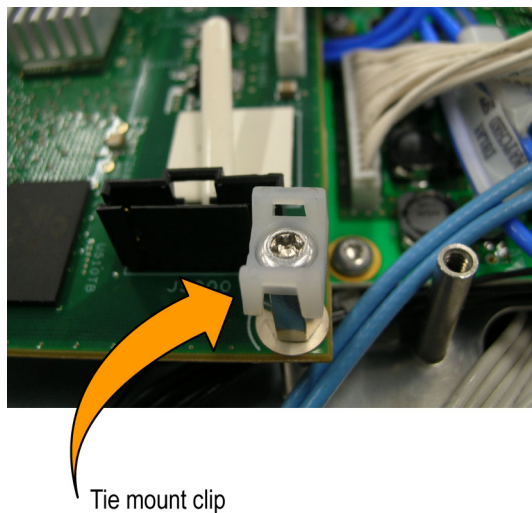

Figure 4-24: Tie mount clip

5. Remove the two cable posts.
6. Disconnect the ribbon cables at J1050, J2000, and J5000 from the AWG12G board.
7. Disconnect these cables:
 - The cable at J115A from the AWG12G board to the CH1 OUT10G board (J150).
 - The cable at J116A from the AWG12G board to the CH1 OUT10G board (J170).
 - The cable at J1430 from the AWG12G board to the Trigger Input connector.
 - The cable at J1440 from the AWG12G board to the Event Input connector.
 - The cables from J100, J110, J600, and J700 on the CH1 OUT10G board.
8. Remove the 9 screws securing the AWG12G board to the chassis.
9. Cut two zip-ties to expose the screws.
10. Remove the two screws, and then remove the hexagon post.
11. Lift the board away from the chassis.
12. Disconnect the ribbon cable at J1000 on the AWG12G board.
13. Disconnect these cables:
 - The cable at J110A from the AWG12G board to the CH1 OUT10G board (J100).
 - The cable at J111A from the AWG12G board to the CH1 OUT10G board (J110).
 - The cable at J100A from the AWG12G board to the CH1 OUT10G board (J600).
 - The cable at J101A from the AWG12G board to the CH1 OUT10G board (J700).

Installation. To install, reverse this procedure.

AWG12G 2 CH Board

You need a screwdriver with a T-15 Torx tip and pliers (items 1, 2, and 8).

Removal. To remove the AWG12G 2 channel board, follow these steps: (See Figure 4-19 on page 4-40.)

1. Remove the handle unit, snaps, cosmetic covers, front-trim unit, EMI covers, CLK12G module, and relay unit (for Option 02 or 06).
2. Orient the instrument so that the top is on the work surface.

3. Use a wire cutter to remove the two cable ties. (See Figure 4-23 on page 4-45.)
4. Remove the two screws, tie mount clips, and cable posts. (See Figure 4-24 on page 4-45.)
5. Disconnect the ribbon cables at J1050, J2000, and J5000 from the AWG12G board.
6. Disconnect these cables:
 - The cable at J115A from the AWG12G board to the CH1 OUT10G board (J150).
 - The cable at J116A from the AWG12G board to the CH1 OUT10G board (J170).
 - The cable at J115B from the AWG12G board to the CH2 OUT10G board (J150).
 - The cable at J116B from the AWG12G board to the CH2 OUT10G board (J170).
 - The cable at J1430 from the AWG12G board to the Trigger Input connector.
 - The cable at J1440 from the AWG12G board to the Event Input connector.
 - The cables from J100, J110, J600, and J700 on the CH1 OUT10G board.
 - The cables from J100, J110, J600, and J700 on the CH2 OUT10G board.
7. Use a wire cutter to remove the cable tie securing the Dynamic Jump In cable and disconnect it from J1600. The Dynamic Jump In is only available on the AWG7000C Series.
8. Remove the 11 screws securing the AWG12G board to the chassis.
9. Lift the board away from the chassis.

10. Disconnect the ribbon cable at J1000 on the AWG12G board.

11. Disconnect these cables:

- The cable at J110A from the AWG12G board to the CH1 OUT10G board (J100).
- The cable at J111A from the AWG12G board to the CH1 OUT10G board (J110).
- The cable at J100A from the AWG12G board to the CH1 OUT10G board (J600).
- The cable at J101A from the AWG12G board to the CH1 OUT10G board (J700).
- The cable at J110B from the AWG12G board to the CH2 OUT10G board (J100).
- The cable at J111B from the AWG12G board to the CH 2 OUT10G board (J110).
- The cable at J100B from the AWG12G board to the CH2 OUT10G board (J600).
- The cable at J101B from the AWG12G board to the CH2 OUT10G board (J700).

Installation. To install, reverse this procedure.

CH1 OUT10G Board

You need a screwdriver with a T-15 Torx tip and pliers (items 1, 2, and 8).

Removal. To remove the CH1 OUT10G board, follow these steps: (See Figure 4-19 on page 4-40.)

- 1.** Remove the handle unit, snaps, cosmetic covers, front-trim unit, EMI covers, relay unit (for Option 02 or 06), and AWG12G board.
- 2.** Orient the instrument so that the top is on the work surface.
- 3.** Remove the five screws securing the shield bracket to the chassis.
- 4.** Lift the bracket away from the chassis.
- 5.** Disconnect the ribbon cable at J500 from the CH1 OUT10G board.

6. Disconnect these cables:

NOTE. For Option 02 or 06, there are no cable connections at J600 and J700 on the CH1 OUT10G board.

- The cable at J600 from the CH1 OUT10G board to the AWG12G board (J100A).
 - The cable at J700 from the CH1 OUT10G board to the AWG12G board (J101A).
 - The cable at J100 from the CH1 OUT10G board to the AWG12G board (J110A).
 - The cable at J110 from the CH1 OUT10G board to the AWG12G board (J111A).
 - The cable at J150 from the CH1 OUT10G board to the AWG12G board (J115A).
 - The cable at J170 from the CH1 OUT10G board to the AWG12G board (J116A).
 - The cable at J690 from the CH1 OUT10G board to the Channel 1 Analog connector.
 - The cable at J790 from the CH1 OUT10G board to the Channel 1 Analog connector.
 - The cable at J120 from the CH1 OUT10G board to the Channel 1 Mkr 1 connector.
 - The cable at J130 from the CH1 OUT10G board to the Channel 1 Mkr 1 connector.
 - The cable at J160 from the CH1 OUT10G board to the Channel 1 Mkr 2 connector.
 - The cable at J190 from the CH1 OUT10G board to the Channel 1 Mkr 2 connector.
7. Remove the four screws securing the CH1 OUT10G board to the chassis.
8. Lift the board away from the chassis.

Installation. To install, reverse this procedure.

CH2 OUT10G Board You need a screwdriver with a T-15 Torx tip and pliers (items 1, 2, and 8).

Removal. To remove the CH2 OUT10G board, follow these steps: (See Figure 4-19 on page 4-40.)

1. Remove the handle unit, snaps, cosmetic covers, front-trim unit, EMI covers, relay unit (for Option 02 or 06), and AWG12G board.
2. Orient the instrument so that the top is on the work surface.
3. Remove the five screws securing the shield bracket to the chassis.
4. Lift the bracket away from the chassis.
5. Disconnect the ribbon cable at J500 from the CH2 OUT10G board.
6. Disconnect these cables:

NOTE. For Option 02 or 06, there are no cable connections at J600 and J700 on the CH2 OUT10G board.

- The cable at J600 from the CH2 OUT10G board to the AWG12G board (J100B).
- The cable at J700 from the CH2 OUT10G board to the AWG12G board (J101B).
- The cable at J100 from the CH2 OUT10G board to the AWG12G board (J110B).
- The cable at J110 from the CH2 OUT10G board to the AWG12G board (J111B).
- The cable at J150 from the CH2 OUT10G board to the AWG12G board (J115B).
- The cable at J170 from the CH2 OUT10G board to the AWG12G board (J116B).
- The cable at J690 from the CH2 OUT10G board to the Channel 2 Analog connector.
- The cable at J790 from the CH2 OUT10G board to the Channel 2 Analog connector.

- The cable at J120 from the CH2 OUT10G board to the Channel 2 Mkr 1 connector.
 - The cable at J130 from the CH2 OUT10G board to the Channel 2 Mkr 1 connector.
 - The cable at J160 from the CH2 OUT10G board to the Channel 2 Mkr 1 connector.
 - The cable at J190 from the CH2 OUT10G board to the Channel 2 Mkr 1 connector.
7. Remove the four screws securing the CH2 OUT10G board to the chassis.
 8. Lift the board away from the chassis.

Installation. To install, reverse this procedure.

Troubleshooting



WARNING. *To prevent possible injury to service personnel or damage to electrical components, please read Preventing ESD on (See page 4-1, Preventing ESD.).*



WARNING. *Before performing this or any other procedure in this manual, read the General Safety Summary and Service Safety Summary found at the beginning of this manual.*

This section contains information and procedures designed to help you isolate faults to a module.

This section requires that service personnel have the appropriate skills to work on this instrument, including PC troubleshooting and Microsoft Windows operating system skills. Details of PC and Windows operation and service are not in this manual.

For assistance, contact your local Tektronix Service Center.

Required Equipment

You will need a digital multimeter to check power supply voltages, as described on (See page 4-55, *Checking the Power Supply Voltages.*).

Fault Isolation Procedure

Follow the primary troubleshooting tree on the following two pages for fault isolation.

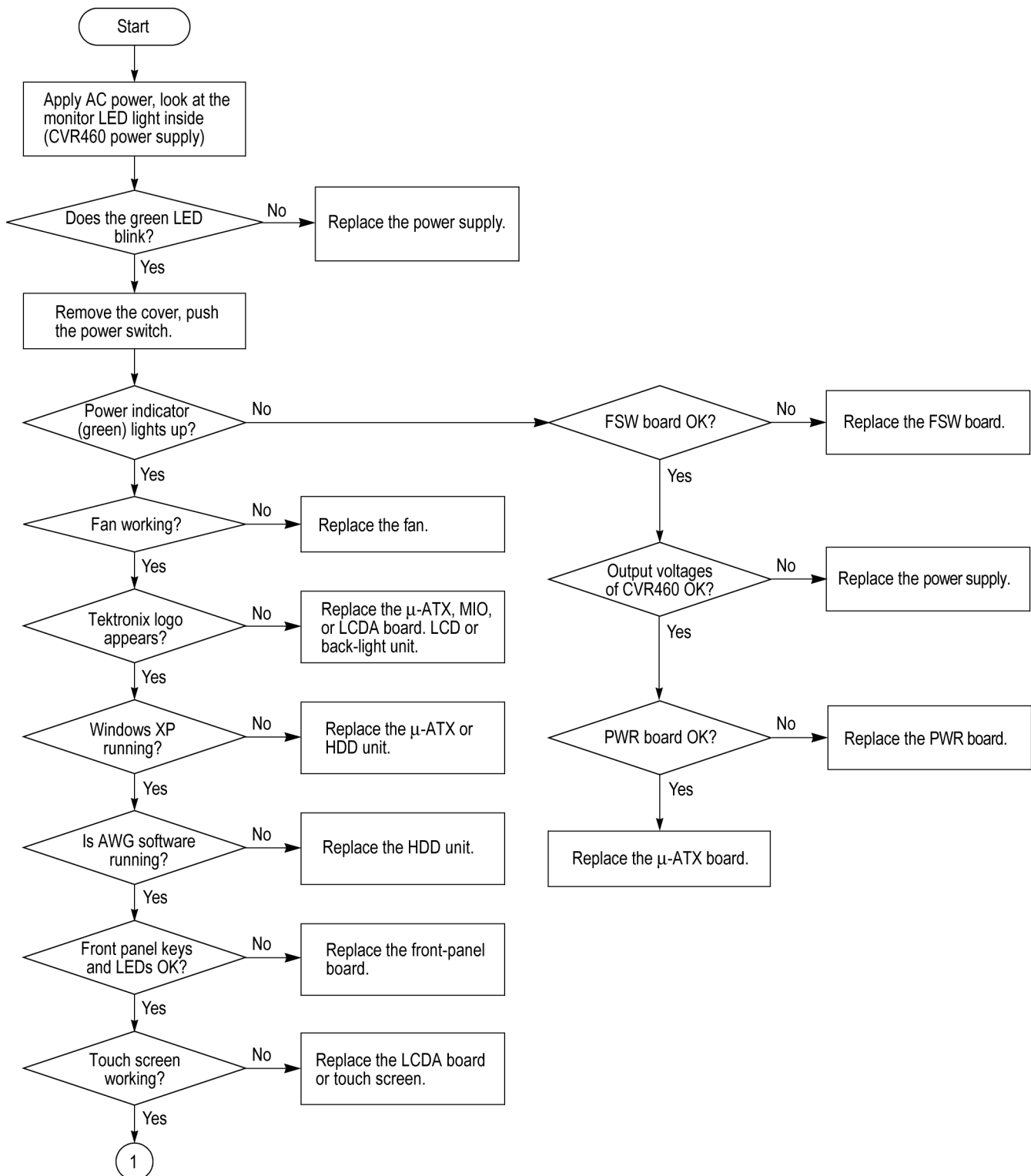

Figure 4-25: Primary troubleshooting tree (1)

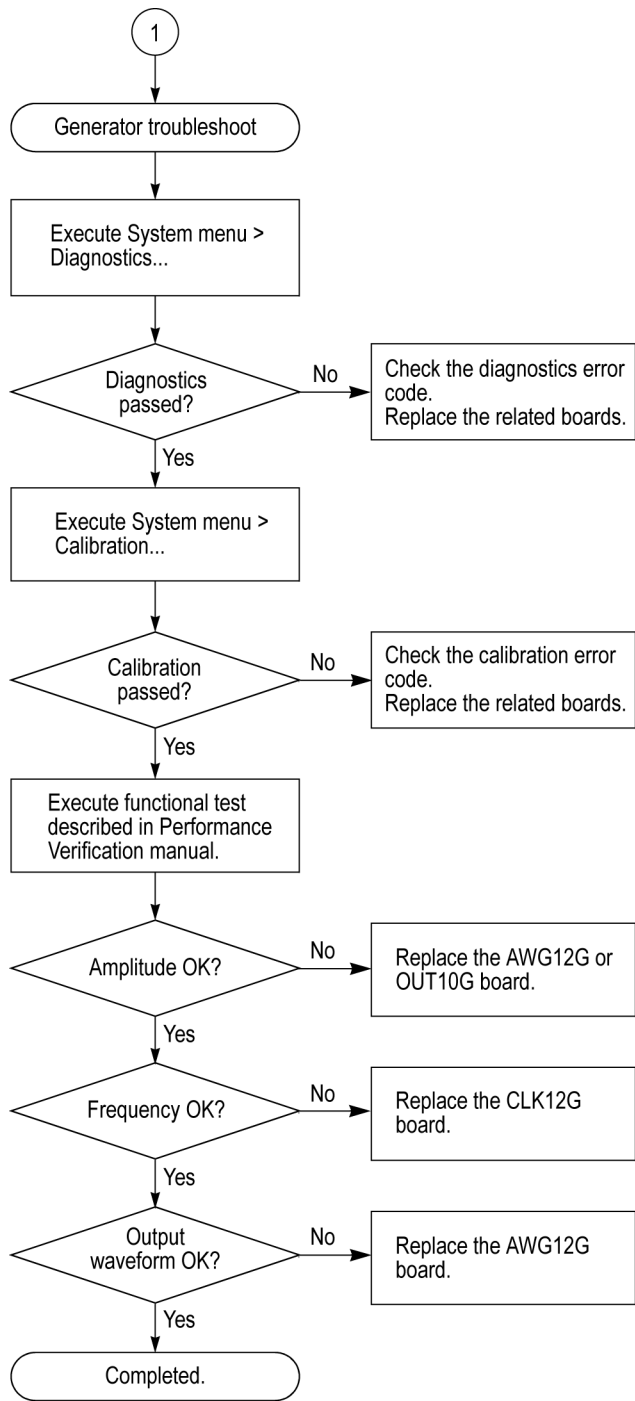

Figure 4-26: Primary troubleshooting tree (2)

Checking the Power Supply Voltages

To check the power supply voltages, power on the instrument and connect the (-) lead of a multimeter to chassis ground.

To measure the output voltages of the power supply, check the voltages at J104 on the PWR board with the multimeter and compare each reading to the values listed in the following table. If the voltages are within the allowance, your power supply is functional.

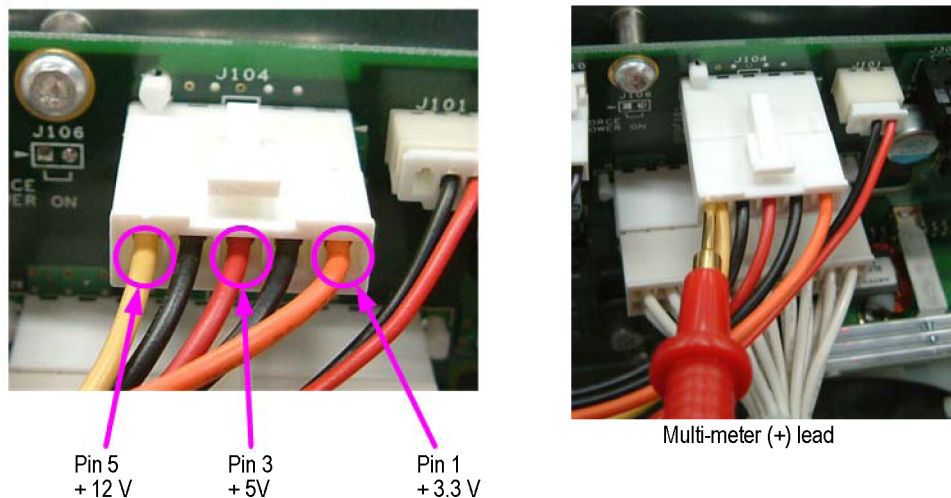

Figure 4-27: PWR board test points

Table 4-4: Power supply voltages

PWR board (J104)	Voltage	Allowance
Pin1	+3.3 V	+3.1 V to +3.5 V
Pin 3	+5 V	+4.7 V to 5.3 V
Pin 5	+12 V	+11.4 V to +12.6 V

Checking the PWR Board Voltages

To measure the output voltages of the PWR board, check the voltages at J2000 on the AWG12G board with the multimeter and compare each reading to the values listed in the following table. If the voltages are within the allowance, your PWR board is functional.

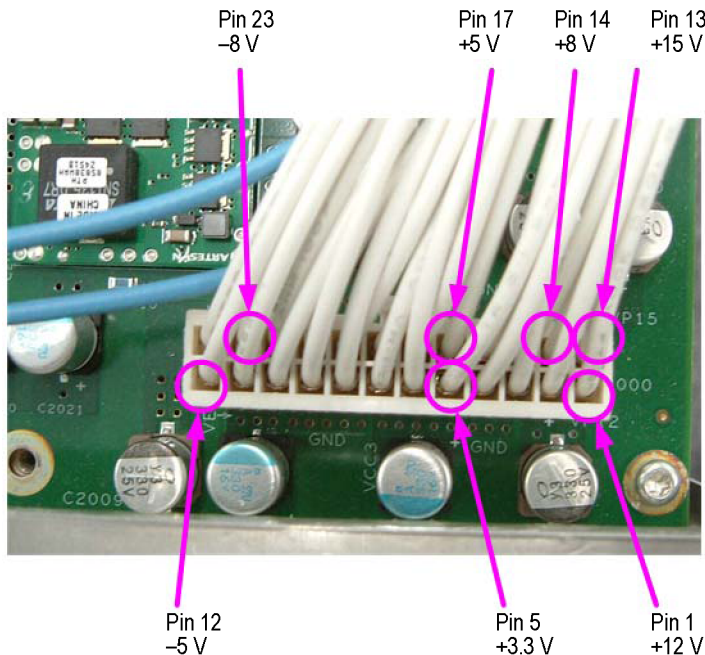

Figure 4-28: AWG12G board test points

Table 4-5: PWR board voltages

AWG12G board (J2000)	Voltage	Allowance
Pin 1	+12 V	+11.4 V to +12.6 V
Pin 5	+3.3 V	+3.1 V to +3.5 V
Pin 12	-5 V	-4.7 to -5.4 V
Pin 13	+15 V	+14.2 V to +15.8 V
Pin 14	+8 V	+7.6 V to +8.4 V
Pin 17	+5 V	+4.7 V to +5.3 V
Pin 23	-8 V	-7.6 to -8.4 V

Instrument Diagnostics

The primary diagnostics for the instrument are accessible through the AWG application software. The Instrument diagnostics check the basic functionality of analog and marker output at every power on. The Instrument Diagnostics run after Windows has booted up and run its own set of system checks. If any failures occur at power on, a pop-up message indicates that a failure has occurred and provides an error code:

- Diagnostics error codes (See Table 4-6 on page 4-58.)
- Calibration error codes (See Table 4-7 on page 4-64.)
- Hardware error codes (See Table 4-8 on page 4-73.)

The power-on tests ensure that the hardware is installed and can be accessed by the software. The tests provide limited diagnostic information, and provide no performance information.

To run the instrument Diagnostics manually, do these steps:

1. Turn off all other applications.
2. From the menu bar, select **System** and then select **Diagnostics...**; the Diagnostics dialog box appears. (See Figure 4-29.)

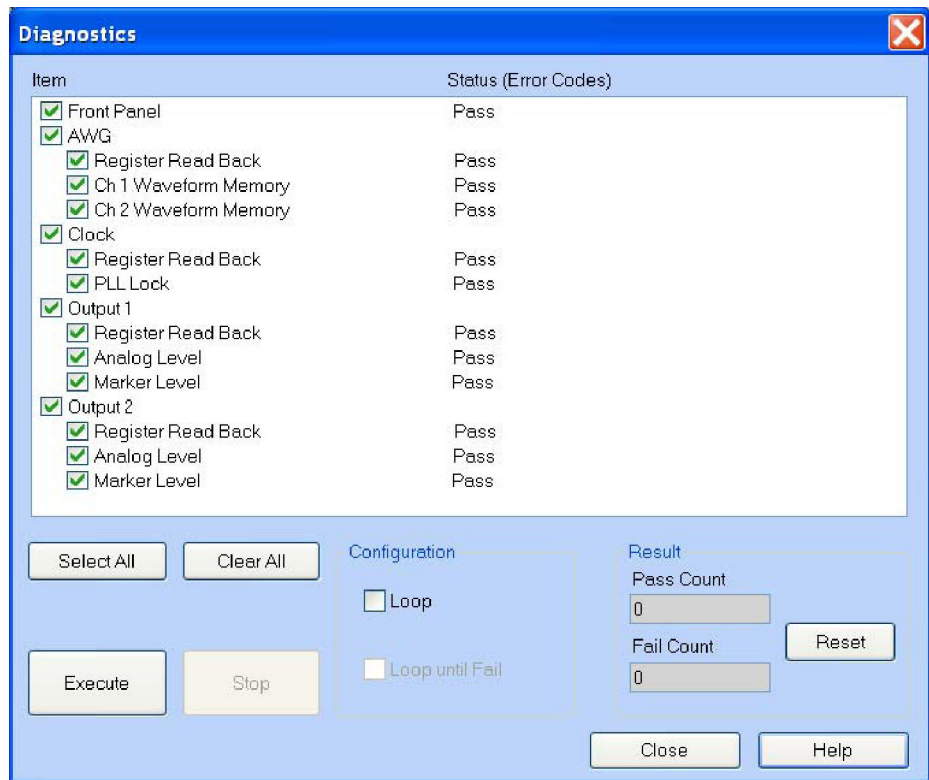

Figure 4-29: Diagnostics dialog box

Table 4-6: Diagnostics error codes

Error code	Error log message	Possible defect on board	Note
12000000	HwDiagAwgRegister AwgController address_0x21 register diag. Fail expected data=xxxx actual data=xxxx	AWG12G	AWG12G: U1000
12000001	HwDiagAwgRegister AwgController address_0x23 register diag. Fail expected data=xxxx actual data=xxxx	AWG12G	AWG12G: U1000
12000002	HwDiagAwgRegister AwgController address_0x30 register diag. Fail expected data=xxxx actual data=xxxx	AWG12G	AWG12G: U1000
12000003	HwDiagAwgRegister AwgController address_0x40 register diag. Fail expected data=xxxx actual data=xxxx	AWG12G	AWG12G: U1000
12000004	HwDiagAwgRegister AwgController address_0x41 register diag. Fail expected data=xxxx actual data=xxxx	AWG12G	AWG12G: U1000
12000005	HwDiagAwgRegister AwgController address_0x42 register diag. Fail expected data=xxxx actual data=xxxx	AWG12G	AWG12G: U1000
12000006	HwDiagAwgRegister AwgController address_0x50 register diag. Fail expected data=xxxx actual data=xxxx	AWG12G	AWG12G: U1000
12000007	HwDiagAwgRegister Ch1 MemoryController-N Communication Fail expected data=xxxx actual data=xxxx -N:PLD no	AWG12G: U1000	N=0 -> U400PA N=1 -> U400QA N=2 -> U400RA N=3 -> U400SA N=4 -> U400TA

Table 4-6: Diagnostics error codes (cont.)

Error code	Error log message	Possible defect on board	Note
120000008	HwDiagAwgRegister Ch2 MemoryController-N Communication Fail expected data=xxxx actual data=xxxx -N:PLD no	AWG12G: U1000	N=0 -> U400PB N=1 -> U400QB N=2 -> U400RB N=3 -> U400SB N=4 -> U400TB
120000009	HwDiagAwgRegister Ch1 TEK0015-TNO address_REG register diag. Fail expected data=xxxx actual data=xxxx TNO: TEK0015 number REG: Register number	AWG12G: U1000	TNO=0 -> U300PA TNO=1 -> U300QA TNO=2 -> U300RA TNO=3 -> U300SA TNO=4 -> U300TA
120000010	HwDiagAwgRegister Ch2TEK0015-TNO address_REG register diag. Fail expected data=xxxx actual data=xxxx TNO: TEK0015 number REG: Register number	AWG12G: U1000	TNO=0 -> U300PB TNO=1 -> U300QB TNO=2 -> U300RB TNO=3 -> U300SB TNO=4 -> U300TB
120000011	HwDiagAwgRegister Ch1 HFD205 address_REG register diag. Fail expected data=xxxx actual data=xxxx REG: Register number	AWG12G	AWG12G: U1000, U100A
120000012	HwDiagAwgRegister Ch2 HFD205 address_REG register diag. Fail expected data=xxxx actual data=xxxx REG: Register number	AWG12G	AWG12G: U1000, U100B
121000000	HwDiagWaveformMemory channel=1, MemoryController-P Data bus Error RAM/PLD-pinName expected data=xxxxxxx actual data=xxxxxxx P:PLD number RAM/PLD-pinName:U5x0-yy-pinRam / U400zz-pinPld	AWG12G	P=0 -> U400PA, U500PA, U510PA P=1 -> U400QA, U500QA, U510QA P=2 -> U400RA, U500RA, U510RA P=3 -> U400SA, U500SA, U510SA P=4 -> U400TA, U500TA, U510TA
121000001	HwDiagWaveformMemory channel=1, MemoryController-P Address Bus Error Address=0XXXXXXXX RAM/PLD-pinName expected data=xxxxxxx actual data=xxxxxxx P:PLD number RAM/PLD-pinName:U5x0-yy-pinRam / U400zz-pinPld	AWG12G	P=0 -> U400PA, U500PA, U510PA P=1 -> U400QA, U500QA, U510QA P=2 -> U400RA, U500RA, U510RA P=3 -> U400SA, U500SA, U510SA P=4 -> U400TA, U500TA, U510TA
121000002	HwDiagWaveformMemory channel1, MemoryController-P Cell HL Error P: PLD number HL: U5x0yy	AWG12G	P=0 -> U500PA, U510PA P=1 -> U500QA, U510QA P=2 -> U500RA, U510RA P=3 -> U500SA, U510SA P=4 -> U500TA, U510TA
121000003	HwDiagWaveformMemory channel=1, MemoryController-P Invert Bit bus RAM/PLD-pinName testNo-testCnt Error expected data=xxxxxxx actual data=xxxxxxx RAM/PLD-pinName:U5x0yy-pinRam / U400zz-pinPld testNo:1st or 2nd testCnt:1st - 4th	AWG12G	P=0 -> U400PA, U500PA, U510PA P=1 -> U400QA, U500QA, U510QA P=2 -> U400RA, U500RA, U510RA P=3 -> U400SA, U500SA, U510SA P=4 -> U400TA, U500TA, U510TA
122000000	HwDiagWaveformMemory channel=2, MemoryController-P Data bus Error RAM/PLD-pinName expected data=xxxxxxx actual data=xxxxxxx, P: PLD number RAM/PLD-pinName:U5x0yy-pinRam / U400zz-pinPld	AWG12G	P=0 -> U400PB, U500PB, U510PB P=1 -> U400QB, U500QB, U510QB P=2 -> U400RB, U500RB, U510RB P=3 -> U400SB, U500SB, U510SB P=4 -> U400TB, U500TB, U510TB

Table 4-6: Diagnostics error codes (cont.)

Error code	Error log message	Possible defect on board	Note
122000001	HwDiagWaveformMemory channel=2, MemoryController-P Address Bus Error Address=0XXXXXXXX RAM/PLD-pinName expected data=xxxxxxx actual data=xxxxxxx P: PLD number RAM/PLD-pinName:U5x0yy-pinRam / U400zz-pinPld	AWG12G	P=0 -> U400PB, U500PB, U510PB P=1 -> U400QB, U500QB, U510QB P=2 -> U400RB, U500RB, U510RB P=3 -> U400SB, U500SB, U510SB P=4 -> U400TB, U500TB, U510TB
122000002	HwDiagWaveformMemory channel2, MemoryController-P Cell HL Error P: PLD number HL: U5x0yy	AWG12G	P=0 -> U500PB, U510PB P=1 -> U500QB, U510QB P=2 -> U500RB, U510RB P=3 -> U500SB, U510SB P=4 -> U500TB, U510TB
122000003	HwDiagWaveformMemory channel=2, MemoryController-P Invert Bit bus RAM/PLD-pinName testNo-testCnt Error expected data=xxxxxxx actual data=xxxxxxx P: PLD number RAM/PLD-pinName:U5x0yy-pinRam / U400zz-pinPld testNo:1'st or 2'nd testCnt:1'st - 4'th	AWG12G	P=0 -> U400PB, U500PB, U510PB P=1 -> U400QB, U500QB, U510QB P=2 -> U400RB, U500RB, U510RB P=3 -> U400SB, U500SB, U510SB P=4 -> U400TB, U500TB, U510TB
130000000	HwDiagClockRegister PLL_MUX_HIGH=0	AWG12G, CLK12G	AWG12G: U1000 CLK12G: U3200
130000001	HwDiagClockRegister PLL_MUX_LOW=1	AWG12G, CLK12G	AWG12G: U1000 CLK12G: U3200
131000000	HwDiagClockPll 7.5GHz YIG tuning error	AWG12G, CLK12G	AWG12G: U1000, U1040 CLK12G: U3200, U3250, Y3100, Y3280
131000001	HwDiagClockPll 7.5GHz PLL Unlocked	AWG12G, CLK12G	AWG12G: U1000, U1040 CLK12G: U3200, U3250, Y3100, Y3280
131000002	HwDiagClockPll 1GHz PLL Locked	AWG12G, CLK12G	AWG12G: U1000 CLK12G: U3200
131000003	HwDiagClockPll 4.9GHz YIG tuning error	AWG12G, CLK12G	AWG12G: U1000, U1040 CLK12G: U3200, U3250, Y3100, Y3280
131000004	HwDiagClockPll 4.9GHz PLL Unlocked	AWG12G, CLK12G	AWG12G: U1000, U1040 CLK12G: U3200, U3250, Y3100, Y3280
131000005	HwDiagClockPll 10.1GHz YIG tuning error	AWG12G, CLK12G	AWG12G: U1000, U1040 CLK12G: U3200, U3250, Y3100, Y3280
131000006	HwDiagClockPll 10.1GHz PLL Unlocked	AWG12G, CLK12G	AWG12G: U1000, U1040 CLK12G: U3200, U3250, Y3100, Y3280
140000000	The error occurred in the EEPROM read. 1st=FST 2nd=SND FST: the data that is received from EEPROM at the first read check SND: the data that is received from EEPROM at the second read check, which is implemented after writing 0x55 to EEPROM	OUT10G	OUT10G-CH1: U500, U550
140000001	Message varies depending on the situation.	OUT10G	OUT10G-CH1: U500, U550
1410P0001	Analog Level Diag CH1 positive (negative) 5db attenuator failed. expected 0.56234, actual xxxxx	OUT10G	OUT10G: K610, K710

Table 4-6: Diagnostics error codes (cont.)

Error code	Error log message	Possible defect on board	Note
1410P0002	Analog Level Diag CH1 positive (negative) 5db attenuator failed. expected 0.56234, actual xxxxx	OUT10G	OUT10G: K610, K710
1410P0003	Analog Level Diag CH1 positive (negative) 10db attenuator failed. expected 0.31627, actual xxxxx	OUT10G	OUT10G: K620, K720
1410P0004	Analog Level Diag CH1 positive (negative) 20db attenuator failed. expected 0.100000, actual xxxxx	OUT10G	OUT10G: K630, K730
1410P0005	Analog Level Diag CH1 positive (negative) 50mhz filter failed. expected 0.992, actual xxxxx	OUT10G	OUT10G: K660, K760
1410P0006	Analog Level Diag CH1 positive (negative) 200mhz filter failed. expected 0.998, actual xxxxx	OUT10G	OUT10G: K670, K770
1410P0007	Analog Level Diag CH1 positive (negative) amplitude cal failed. expected 2.07, actual xxxxx	OUT10G	OUT10G: U800
1410P0008	Analog Level Diag CH1 positive (negative) hfd dac reference failed.	AWG12G	AWG12G: U100A, U150A
1410P0009	Analog Level Diag CH1 positive (negative) output offset failed. expected 0.50V(0.0V), actual xxxxx	OUT10G	OUT10G: U900, U910, U920
141000010	Analog Level Diag CH1 internal offset 8bit failed. expected 0.0mV, actual xxxxxmV	AWG12G	AWG12G: U100A, U150A
141000011	Analog Level Diag CH1 internal offset 10bit failed. expected 0.0mV, actual xxxxxmV	AWG12G	AWG12G: U100A, U150A
141000012	Analog Level Diag CH1 can't find 8bit outamp offset cross point. expected 0.0mV, actual pos: xxxxxmV, neg: xxxxxmV	AWG12G	AWG12G: U100A, U150A
141000013	Analog Level Diag CH1 can't find 10bit outamp offset cross point. expected 0.0mV, actual pos: xxxxxmV, neg: xxxxxmV	AWG12G	AWG12G: U100A, U150A
141000015	Analog Level Diag CH1 5db attenuator gain balance failed.	OUT10G	OUT10G: K610, K710
141000016	Analog Level Diag CH1 5db attenuator gain balance failed.	OUT10G	OUT10G: K610, K710
141000017	Analog Level Diag CH1 10db attenuator gain balance failed.	OUT10G	OUT10G: K620, K720
141000018	Analog Level Diag CH1 20db attenuator gain balance failed.	OUT10G	OUT10G: K630, K730
141000019	Analog Level Diag CH1 filter 50mhz gain balance failed.	OUT10G	OUT10G: K660, K760
141000020	Analog Level Diag CH1 filter 200mhz gain balance failed.	OUT10G	OUT10G: K670, K770
141000021	Analog Level Diag CH1 amp gain balance failed.	OUT10G	OUT10G: U800
1420M0001	Marker Level Diag CH1 MARKER M offset failed.	OUT10G	U120, U170, U230, U240, U330, U340

Table 4-6: Diagnostics error codes (cont.)

Error code	Error log message	Possible defect on board	Note
1420M0002	Marker Level Diag CH1 MARKER M positive offset failed.	OUT10G	U120, U170, U230, U240, U330, U340
1420M0003	Marker Level Diag CH1 MARKER M negative offset failed.	OUT10G	U120, U170, U230, U240, U330, U340
1420M0004	Marker Level Diag CH1 MARKER M amplitude failed.	OUT10G	U120, U170, U230, U240, U330, U340
1420M0005	Marker Level Diag CH1 MARKER M amplitude correction failed.	OUT10G	U120, U170, U230, U240, U330, U340
150000000	The error occurred in the EEPROM read. 1st=FST 2nd=SND FST: the data that is received from EEPROM at the first read check SND: the data that is received from EEPROM at the second read check, which is implemented after writing 0x55 to EEPROM	OUT10G	OUT10G-CH2: U500, U550
150000001	Message varies depending on the situation.	OUT10G	OUT10G-CH1: U500, U550
1510P0001	Analog Level Diag CH2 positive (negative) 5db attenuator failed. expected 0.56234, actual xxxxx	OUT10G	OUT10G: K610, K710
1510P0002	Analog Level Diag CH2 positive (negative) 5db attenuator failed. expected 0.56234, actual xxxxx	OUT10G	OUT10G: K610, K710
1510P0003	Analog Level Diag CH2 positive (negative) 10db attenuator failed. expected 0.31627, actual xxxxx	OUT10G	OUT10G: K620, K720
1510P0004	Analog Level Diag CH2 positive (negative) 20db attenuator failed. expected 0.100000, actual xxxxx	OUT10G	OUT10G: K630, K730
1510P0005	Analog Level Diag CH2 positive (negative) 50mhz filter failed. expected 0.992, actual xxxxx	OUT10G	OUT10G: K660, K760
1510P0006	Analog Level Diag CH2 positive (negative) 200mhz filter failed. expected 0.998, actual xxxxx	OUT10G	OUT10G: K670, K770
1510P0007	Analog Level Diag CH2 positive (negative) amplitude cal failed. expected 2.07, actual xxxxx	OUT10G	OUT10G: U800
1510P0008	Analog Level Diag CH2 positive (negative) hfd dac reference failed.	AWG10G	AWG10G: U100B, U150B
1510P0009	Analog Level Diag CH2 positive (negative) output offset failed. expected 0.50V(0.0V), actual xxxxx	OUT10G	OUT10G: U900, U910, U920
151000010	Analog Level Diag CH2 internal offset 8bit failed. expected 0.0mV, actual xxxxxmV	AWG12G	AWG12G: U100B, U150B
151000011	Analog Level Diag CH2 internal offset 10bit failed. expected 0.0mV, actual xxxxxmV	AWG12G	AWG12G: U100B, U150B
151000012	Analog Level Diag CH2 can't find 8bit outamp offset cross point. expected 0.0mV, actual pos: xxxxxmV, neg: xxxxxmV	AWG12G	AWG12G: U100B, U150B
151000013	Analog Level Diag CH2 can't find 10bit outamp offset cross point. expected 0.0mV, actual pos: xxxxxmV, neg: xxxxxmV	AWG12G	AWG12G: U100B, U150B

Table 4-6: Diagnostics error codes (cont.)

Error code	Error log message	Possible defect on board	Note
151000015	Analog Level Diag CH2 5db attenuator gain balance failed.	OUT10G	OUT10G: K610, K710
151000016	Analog Level Diag CH2 5db attenuator gain balance failed.	OUT10G	OUT10G: K610, K710
151000017	Analog Level Diag CH2 10db attenuator gain balance failed.	OUT10G	OUT10G: K620, K720
151000018	Analog Level Diag CH2 20db attenuator gain balance failed.	OUT10G	OUT10G: K630, K730
151000019	Analog Level Diag CH2 filter 50mhz gain balance failed.	OUT10G	OUT10G: K660, K760
151000020	Analog Level Diag CH2 filter 200mhz gain balance failed.	OUT10G	OUT10G: K670, K770
151000021	Analog Level Diag CH2 amp gain balance failed.	OUT10G	OUT10G: U800
1520M0001	Marker Level Diag CH2 MARKER M offset failed.	OUT10G	U120, U170, U230, U240, U330, U340
1520M0002	Marker Level Diag CH2 MARKER M positive offset failed.	OUT10G	U120, U170, U230, U240, U330, U340
1520M0003	Marker Level Diag CH2 MARKER M negative offset failed.	OUT10G	U120, U170, U230, U240, U330, U340
1520M0004	Marker Level Diag CH2 MARKER M amplitude failed.	OUT10G	U120, U170, U230, U240, U330, U340
1520M0005	Marker Level Diag CH2 MARKER M amplitude correction failed.	OUT10G	U120, U170, U230, U240, U330, U340
190000000	TekLink receive error Send=TR Recv=RV TR:Transmission data RV:Receive data	MIO	MIO: U300

Calibration Error

To run the instrument calibration, do these steps:

1. Turn off all other applications.
2. From the menu bar, select **System** and then select **Calibration...**; the Calibration dialog box appears.

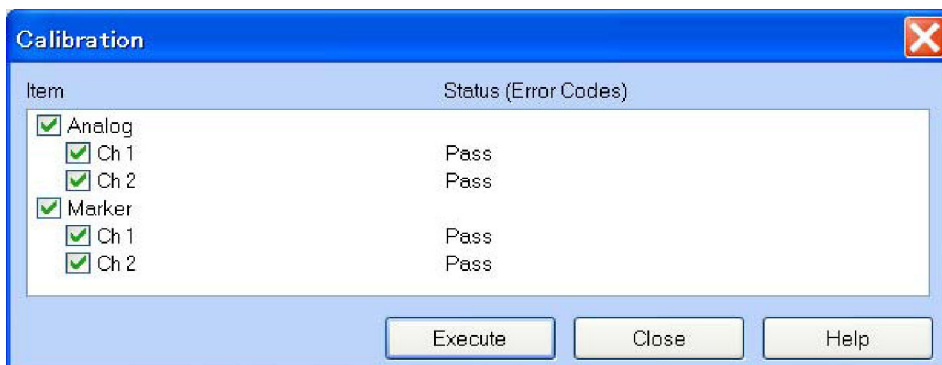

Figure 4-30: Calibration dialog box

Table 4-7: Calibration error codes

Error code	Error log message	Possible defect on board	Note
200XP0001	Analog Level Calibration CHX positive (negative) 5db attenuator failed. expected 0.56234, actual xxxxx	OUT10G	OUT10G: K610, K710
200XP0002	Analog Level Calibration CHX positive (negative) 5db attenuator failed. expected 0.56234, actual xxxxx	OUT10G	OUT10G: K610, K710
200XP0003	Analog Level Calibration CHX positive (negative) 10db attenuator failed. expected 0.31627, actual xxxxx	OUT10G	OUT10G: K620, K720
200XP0004	Analog Level Calibration CHX positive (negative) 20db attenuator failed. expected 0.100000, actual xxxxx	OUT10G	OUT10G: K630, K730
200XP0005	Analog Level Calibration CHX positive (negative) 50mhz filter failed. expected 0.992, actual xxxxx	OUT10G	OUT10G: K660, K760
200XP0006	Analog Level Calibration CHX positive (negative) 200mhz filter failed. expected 0.998, actual xxxxx	OUT10G	OUT10G: K670, K770
200XP0007	Analog Level Calibration CHX positive (negative) amplitude cal failed. expected 2.07, actual xxxxx	OUT10G	OUT10G: U800
200XP0008	Analog Level Calibration CHX positive (negative) hfd dac reference failed.	OUT10G	AWG10G: U100A/B, U150A/B
200XP0009	Analog Level Calibration CHX positive (negative) output offset failed. expected 0.50V(0.0V), actual xxxxx	OUT10G	OUT10G: U900, U910, U920
200XP0010	Analog Level Calibration CHX internal offset 8bit failed. expected 0.0mV, actual xxxxxmV	OUT10G	AWG10G: U100A/B, U150A/B

Table 4-7: Calibration error codes (cont.)

Error code	Error log message	Possible defect on board	Note
200XP0011	Analog Level Calibration CHX internal offset 10bit failed. expected 0.0mV, actual xxxxxmV	OUT10G	AWG10G: U100A/B, U150A/B
200XP0012	Analog Level Calibration CHX can't find 8bit outamp offset cross point. expected 0.0mV, actual pos: xxxxxmV, neg: xxxxxmV	AWG12G	AWG12G: U100A/B, U150A/B
200XP0013	Analog Level Calibration CHX can't find 10bit outamp offset cross point. expected 0.0mV, actual pos: xxxxxmV, neg: xxxxxmV	AWG12G	AWG12G: U100A/B, U150A/B
200XP0015	Analog Level Calibration CHX 5db attenuator gain balance failed.		
200XP0016	Analog Level Calibration CHX 5db attenuator gain balance failed.		
200XP0017	Analog Level Calibration CHX 10db attenuator gain balance failed.		
200XP0018	Analog Level Calibration CHX 20db attenuator gain balance failed.		
200XP0019	Analog Level Calibration CHX filter 50mhz gain balance failed.		
200XP0020	Analog Level Calibration CHX filter 200mhz gain balance failed.		
200XP0021	Analog Level Calibration CHX amp gain balance failed.		
210XM0001	Marker Level Calibration CHX MARKER M offset failed.	OUT10G	OUT10G: U120, U170, U230, U240, U330, U340
210XM0002	Marker Level Calibration CHX MARKER M positive offset failed.	OUT10G	OUT10G: U120, U170, U230, U240, U330, U340
210XM0003	Marker Level Calibration CHX MARKER M negative offset failed.	OUT10G	OUT10G: U120, U170, U230, 240, U330, U340
210XM0004	Marker Level Calibration CHX MARKER M amplitude failed.	OUT10G	OUT10G: U120, U170, U230, U240, U330, U340
210XM0005	Marker Level Calibration CHX MARKER M amplitude correction failed.	OUT10G	OUT10G: U120, U170, U230, U240, U330, U340
211XMP006	Marker Level Calibration CHX MARKER M positive(negative) input level failed.	AWG12G	AWG12G: U1000, U100A/B
220000000	HwExecMarkerDelayCal (channel=1) A maximum and a minimum difference are smaller than 80ps at coarse=15	AWG12G	AWG12G: U1000, U100A
220000001	HwExecMarkerDelayCal (channel=2) A maximum and a minimum difference are smaller than 80ps at coarse=15	AWG12G	AWG12G: U1000, U100B
220000002	HwExecMarkerDelayCal (channel=1) Frequency measurement cannot be performed.	AWG12G	AWG12G: U1000, U100A
220000003	HwExecMarkerDelayCal (channel=2) Frequency measurement cannot be performed.	AWG12G	AWG12G: U1000, U100B

Table 4-7: Calibration error codes (cont.)

Error code	Error log message	Possible defect on board	Note
220000004	HwExecMarkerDelayCal (channel=1) A maximum value is smaller than 300ps at coarse=15.	AWG12G	AWG12G: U100A
220000005	HwExecMarkerDelayCal (channel=2) A maximum value is smaller than 300ps at coarse=15.	AWG12G	AWG12G: U100B
220000006	HwExecMarkerDelayCal (channel=1) There are not data in ascending order coarse=%d	AWG12G	AWG12G: U1000, U100A, U195A
220000007	HwExecMarkerDelayCal (channel=2) There are not data in ascending order coarse=%d	AWG12G	AWG12G: U1000, U100B, U195B
231000000	N/A	AWG12G	AWG12G:U100A/B, U4000, U1040
241000000	N/A	AWG12G	AWG12G: U100A/B, U4000
251000000	The Cal value is not found.(10G-Write)	AWG12G	AWG12G:U1000, U400A/B
251000001	The Cal value is not found.(8G-Write)	AWG12G	AWG12G:U1000, U400A/B
251000002	The Cal value is not found.(10G-Read)	AWG12G	AWG12G:U1000, U400A/B
251000004	The Cal value is not found.(Waveform RAM Write Timing CH1)	AWG12G	AWG12G:U400A, U500A, U510A
251000005	The Cal value is not found.(Waveform RAM Write Timing CH2)	AWG12G	AWG12G:U400A, U500A, U510B
251000006	Invalid NG Areas.(10G-Write)	AWG12G	AWG12G:U1000, U400A/B
251000007	Invalid NG Areas.(8G-Write)	AWG12G	AWG12G:U1000, U400A/B
251000008	The Cal value is not found.(12G-Write)	AWG12G	AWG12G:U1000, U400A/B
251000009	The Cal value is not found.(12G-Read)	AWG12G	AWG12G:U1000, U400A/B
251000010	Invalid NG Areas.(12G-Write)	AWG12G	AWG12G:U1000, U400A/B
260000200	Waveform write error.	AWG12G	AWG12G: U400, U500, U510
260000001	The Cal value is not found. (ch1_ram_address_timing_1@10GHz)	AWG12G	AWG12G: U400A, U500A, U510A
260000002	The Cal value is not found. (ch2_ram_address_timing_1@10GHz)	AWG12G	AWG12G: U400B, U500B, U510B
260000003	The Cal value is not found. (ch1_ram_address_timing_1@8GHz)	AWG12G	AWG12G: U400A, U500A, U510A
260000004	The Cal value is not found. (ch2_ram_address_timing_1@8GHz)	AWG12G	AWG12G: U400B, U500B, U510B
260000005	The Cal value is not found. (ch1_ram_data_timing_1@10GHz)	AWG12G	AWG12G: U400A, U500A, U510A
260000006	The Cal value is not found. (ch2_ram_data_timing_1@10GHz)	AWG12G	AWG12G: U400B, U500B, U510B
260000007	The Cal value is not found. (ch1_ram_data_timing_2@8GHz)	AWG12G	AWG12G: U400A, U500A, U510A
260000008	The Cal value is not found. (ch2_ram_data_timing_2@8GHz)	AWG12G	AWG12G: U400B, U500B, U510B

Table 4-7: Calibration error codes (cont.)

Error code	Error log message	Possible defect on board	Note
260000101	The difference of ch1_ram_address_timing_1 and ch2_ram_address_timing_1 is larger than 96.(@10GHz)	AWG12G	AWG12G: U400, U500, U510
260000103	The difference of ch1_ram_address_timing_2 and ch2_ram_address_timing_2 is larger than 96.(@8GHz)	AWG12G	AWG12G: U400, U500, U510
260001001	Invalid NG Areas. (ch1_ram_address_timing@10GHz)	AWG12G	AWG12G: U400xA
260001002	Invalid NG Areas. (ch2_ram_address_timing@10GHz)	AWG12G	AWG12G: U400xB
260001003	Invalid NG Areas. (ch1_ram_address_timing@8GHz)	AWG12G	AWG12G: U400xA
260001004	Invalid NG Areas. (ch2_ram_address_timing@8GHz)	AWG12G	AWG12G: U400xB
260000105	The difference of ch1_ram_data_timing_1 and ch2_ram_data_timing_1 is larger than 96.(@10GHz)	AWG12G	AWG12G: U400, U500, U510
260000107	The difference of ch1_ram_data_timing_2 and ch2_ram_data_timing_2 is larger than 96.(@8GHz)	AWG12G	AWG12G: U400, U500, U510
260000108	The difference of ch1_ram_data_timing_1 - ch1_ram_data_timing_2 is larger than 96.	AWG12G	AWG12G: U400A, U500A, U510A
260000109	The difference of ch2_ram_data_timing_1 - ch2_ram_data_timing_2 is larger than 96.	AWG12G	AWG12G: U400B, U500B, U510B
260000011	The Cal value is not found.(ch1_pld_timing_1@10GHz)	AWG12G	AWG12G: U400A
260000012	The Cal value is not found. (ch2_pld_timing_1@10GHz)	AWG12G	AWG12G: U400B
260000013	The Cal value is not found. (ch1_pld_timing_2@8GHz)	AWG12G	AWG12G: U400A
260000014	The Cal value is not found. (ch2_pld_timing_2@8GHz)	AWG12G	AWG12G: U400B
260000015	The Cal value is not found. (ch1_pld_timing_3@10GHz)	AWG12G	AWG12G: U400A
260000016	The Cal value is not found. (ch2_pld_timing_3@10GHz)	AWG12G	AWG12G: U400B
260000017	Temperature changed 5 degrees or more. (@PLD Timing Cal.)		
260000111	The difference of ch1_pld_timing_1 and ch2_pld_timing_1 is larger than 48.(@10GHz)	AWG12G	AWG12G: U400
260000113	The difference of ch1_pld_timing_2 and ch2_pld_timing_2 is larger than 48.(@8GHz)	AWG12G	AWG12G: U400
260000115	The difference of ch1_pld_timing_3 and ch2_pld_timing_3 is larger than 48.(@10GHz)	AWG12G	AWG12G: U400
260001005	Invalid NG Areas.(ch1_pld_timing@10GHz)	AWG12G	AWG12G: U400xA
260001006	Invalid NG Areas.(ch2_pld_timing@10GHz)	AWG12G	AWG12G: U400xB
260001007	Invalid NG Areas.(ch1_pld_timing@8GHz)	AWG12G	AWG12G: U400xA
260001008	Invalid NG Areas.(ch2_pld_timing@8GHz)	AWG12G	AWG12G: U400xB
260000021	The Cal value is not found.(tek15_ch1_timing_1)	AWG12G	AWG12G: U300A
260000022	The Cal value is not found.(tek15_ch2_timing_1)	AWG12G	AWG12G: U300B
260000023	The Cal value is not found.(tek15_ch1_timing_2)	AWG12G	AWG12G: U300A
260000024	The Cal value is not found.(tek15_ch2_timing_2)	AWG12G	AWG12G: U300B

Table 4-7: Calibration error codes (cont.)

Error code	Error log message	Possible defect on board	Note
260000025	A coefficient is not also 5 or 6.(tek15_ch1_k)	AWG12G	AWG12G: U300A
260000026	A coefficient is not also 5 or 6.(tek15_ch2_k)	AWG12G	AWG12G: U300B
260000027	The Cal value is not found.(tek15_ch1_ng_f)	AWG12G	AWG12G: U300A
260000028	The Cal value is not found.(tek15_ch2_ng_f)	AWG12G	AWG12G: U300B
260000029	Temperature changed 5 degrees or more.(@Magic Cal.)		
260000121	The difference of tek15_ch1_timing_1 and tek15_ch2_timing_1 is larger than 150ps.	AWG12G	AWG12G: U300
260000123	The difference of tek15_ch1_timing_2 and tek15_ch2_timing_2 is larger than 150ps.	AWG12G	AWG12G: U300
260000125	tek15_ch1_k and tek15_ch2_k are not equal.	AWG12G	AWG12G: U300
260001009	Invalid NG Areas.(ch1@Magic Cal.)	AWG12G	AWG12G: U300xA
260001010	Invalid NG Areas.(ch2@Magic Cal.)	AWG12G	AWG12G: U300xB
261000001	The Cal value is not found. (ch1_ram_address_timing_1@12GHz)	AWG12G	AWG12G:U400A, U500A, U510A
261000002	The Cal value is not found. (ch2_ram_address_timing_1@12GHz)	AWG12G	AWG12G:U400B, U500B, U510B
261000003	The Cal value is not found. (ch1_ram_address_timing_1@10GHz)	AWG12G	AWG12G:U400A, U500A, U510A
261000004	The Cal value is not found. (ch2_ram_address_timing_1@10GHz)	AWG12G	AWG12G:U400B, U500B, U510B
261000005	The Cal value is not found. (ch1_ram_data_timing_1@12GHz)	AWG12G	AWG12G:U400A, U500A, U510A
261000006	The Cal value is not found. (ch2_ram_data_timing_1@12GHz)	AWG12G	AWG12G:U400B, U500B, U510B
261000007	The Cal value is not found. (ch1_ram_data_timing_2@10GHz)	AWG12G	AWG12G:U400A, U500A, U510A
261000008	The Cal value is not found. (ch2_ram_data_timing_2@10GHz)	AWG12G	AWG12G:U400B, U500B, U510B
261000101	The difference of ch1_ram_address_timing_1 and ch2_ram_address_timing_1 is larger than 48.(@12GHz)	AWG12G	AWG12G:U400A/B, U500A/B, U510A/B
261000103	The difference of ch1_ram_address_timing_2 and ch2_ram_address_timing_2 is larger than 48.(@10GHz)	AWG12G	AWG12G:U400A/B, U500A/B, U510A/B
261000105	The difference of ch1_ram_data_timing_1 and ch2_ram_data_timing_1 is larger than 48.(@12GHz)	AWG12G	AWG12G:U400A/B, U500A/B, U510A/B
261000107	The difference of ch1_ram_data_timing_2 and ch2_ram_data_timing_2 is larger than 48.(@10GHz)	AWG12G	AWG12G:U400A/B, U500A/B, U510A/B
261000108	The difference of ch1_ram_data_timing_1 - ch1_ram_data_timing_2 is larger than 48.	AWG12G	AWG12G:U400A/B, U500A/B, U510A/B
261000109	The difference of ch2_ram_data_timing_1 - ch2_ram_data_timing_2 is larger than 48.	AWG12G	AWG12G:U400A/B, U500A/B, U510A/B

Table 4-7: Calibration error codes (cont.)

Error code	Error log message	Possible defect on board	Note
261000200	Waveform write error	AWG12G	AWG12G:U1000, U400A/B, U500A/B, U510A/B
261001001	Invalid NG Areas. (ch1_ram_address_timing@12GHz)	AWG12G	
261001002	Invalid NG Areas. (ch2_ram_address_timing@12GHz)	AWG12G	
261001003	Invalid NG Areas. (ch1_ram_address_timing@10GHz)	AWG12G	
261001004	Invalid NG Areas. (ch2_ram_address_timing@10GHz)	AWG12G	
262000011	The Cal value is not found. (ch1_pld_timing_1@12GHz)	AWG12G	AWG12G:U300A, U400A
262000012	The Cal value is not found. (ch2_pld_timing_1@12GHz)	AWG12G	AWG12G:U300B, U400B
262000013	The Cal value is not found. (ch1_pld_timing_2@10GHz)	AWG12G	AWG12G:U300A, U400A
262000014	The Cal value is not found. (ch2_pld_timing_2@10GHz)	AWG12G	AWG12G:U300B, U400B
262000015	The Cal value is not found. (ch1_pld_timing_3@12GHz)	AWG12G	AWG12G:U300A, U400A
262000016	The Cal value is not found. (ch2_pld_timing_3@12GHz)	AWG12G	AWG12G:U300B, U400B
262000017	Temperature changed 5 degrees or more.(@PLD Timing Cal.)	AWG12G	Ambient temperature
262000111	The difference of ch1_pld_timing_1 and ch2_pld_timing_1 is larger than 24.(@12GHz)	AWG12G	AWG12G:U300A/B, U400A/B
262000113	The difference of ch1_pld_timing_2 and ch2_pld_timing_2 is larger than 24.(@10GHz)	AWG12G	AWG12G:U300A/B, U400A/B
262000115	The difference of ch1_pld_timing_3 and ch2_pld_timing_3 is larger than 24.(@12GHz)	AWG12G	AWG12G:U300A/B, U400A/B
262001005	Invalid NG Areas. (ch1_pld_timing@12GHz)	AWG12G	AWG12G:U300A,U400A
262001006	Invalid NG Areas. (ch2_pld_timing@12GHz)	AWG12G	AWG12G:U300B,U400B
262001007	Invalid NG Areas. (ch1_pld_timing@10GHz)	AWG12G	AWG12G:U300A,U400A
262001008	Invalid NG Areas. (ch2_pld_timing@10GHz)	AWG12G	AWG12G:U300B,U400B
263000025	tek15_ch1_k is not 6, 7 or 8.	AWG12G	AWG12G:U100A, U300A
263000026	tek15_ch2_k is not 6, 7 or 8.	AWG12G	AWG12G:U100B, U300B
263000027	The Cal value is not found. (tek15_ch1_ng_f)	AWG12G	AWG12G:U100A, U300A
263000028	The Cal value is not found. (tek15_ch2_ng_f)	AWG12G	AWG12G:U100B, U300B
263000029	Temperature changes 5 degrees or more during MagicCal.	AWG12G	Ambient temperature
263000031	Set end point before start point. Or too large delay was set as reference delay (CH1).	AWG12G	AWG12G:U100A,U300A
263000032	Set end point before start point. Or too large delay was set as reference delay (CH2).	AWG12G	AWG12G:U100B, U300B
263000125	tek15_ch1_k and tek15_ch2_k are not equal.	AWG12G	AWG12G:U100A/B,U300A/B
263001106	Temperature changes 5 degrees or more from PLD timing Cal.	AWG12G	Ambient temperature

Table 4-7: Calibration error codes (cont.)

Error code	Error log message	Possible defect on board	Note
263XY0021	The Cal value is not found at TEK0015-X bit Y.(tek15_ch1_timing_1)	AWG12G	AWG12G:U100A, U300A (X=0,1 -> P; X=2,3 -> Q; X=4,5 -> R; X=6,7 -> S; X=8,9 -> T)
263XY0022	The Cal value is not found at TEK0015-X bit Y.(tek15_ch2_timing_1)	AWG12G	AWG12G:U100A, U300B (X=0,1 -> P; X=2,3 -> Q; X=4,5 -> R; X=6,7 -> S; X=8,9 -> T)
263XY0023	The Cal value is not found at TEK0015-X bit Y.(tek15_ch1_timing_2)	AWG12G	AWG12G:U100A, U300A (X=0,1 -> P; X=2,3 -> Q; X=4,5 -> R; X=6,7 -> S; X=8,9 -> T)
263XY0024	The Cal value is not found at TEK0015-X bit Y.(tek15_ch2_timing_2)	AWG12G	AWG12G:U100A, U300B (X=0,1 -> P; X=2,3 -> Q; X=4,5 -> R; X=6,7 -> S; X=8,9 -> T)
263XY0041	The Cal value is not found at TEK0015-X bit Y.(tek15_ch1_timing_3)	AWG12G	AWG12G:U100A, U300PA
263XY0042	The Cal value is not found at TEK0015-X bit Y.(tek15_ch2_timing_3)	AWG12G	AWG12G:U100B, U300PB
263XY0121	The difference between tek15_ch1_timing_1 and tek15_ch2_timing_1 is larger than 120ps at TEK0015-X bit Y.	AWG12G	AWG12G:U100A/B, U300A/B
263XY0123	The difference between tek15_ch1_timing_2 and tek15_ch2_timing_2 is larger than 120ps at TEK0015-X bit Y.	AWG12G	AWG12G:U100A/B, U300A/B
263XY1009	Invalid NG Areas at CH1 TEK0015-X bit Y.	AWG12G	AWG12G:U100A, U300A
263XY1010	Invalid NG Areas at CH2 TEK0015-X bit Y.	AWG12G	AWG12G:U100B, U300B
263XY1101	Too large delay value was set for TEK0015-X bit Y.	AWG12G	AWG12G: U100A/B, U300A/B (X=0,1 -> P; X=2,3 -> Q; X=4,5 -> R; X=6,7 -> S; X=8,9 -> T)
263XY1102	Too large delay value was set for TEK0015-X bit Y.	AWG12G	AWG12G: U100A, U300A (X=0,1 -> P; X=2,3 -> Q; X=4,5 -> R; X=6,7 -> S; X=8,9 -> T)
263XY1103	Too large delay value was set for TEK0015-X bit Y.	AWG12G	AWG12G: U100B, U300B (X=0,1 -> P; X=2,3 -> Q; X=4,5 -> R; X=6,7 -> S; X=8,9 -> T)
263XY1104	Too large delay value was set for TEK0015-X bit Y.	AWG12G	AWG12G: U100A, U300A (X=0,1 -> P; X=2,3 -> Q; X=4,5 -> R; X=6,7 -> S; X=8,9 -> T)
263XY1105	Too large delay value was set for TEK0015-X bit Y.	AWG12G	AWG12G: U100B, U300B (X=0,1 -> P; X=2,3 -> Q; X=4,5 -> R; X=6,7 -> S; X=8,9 -> T)
263XY1107	Invalid phase transition distance at CH1 TEK0015-X bit Y.	AWG12G	AWG12G: U100A, U300A (X=0,1 -> P; X=2,3 -> Q; X=4,5 -> R; X=6,7 -> S; X=8,9 -> T)

Table 4-7: Calibration error codes (cont.)

Error code	Error log message	Possible defect on board	Note
263XY1108	Invalid phase transition distance at CH2, TEK0015-X bit Y.	AWG12G	AWG12G: U100B, U300B (X=0,1 -> P; X=2,3 -> Q; X=4,5 -> R; X=6,7 -> S; X=8,9 -> T)
270000000	HwExecYigCal PLL read error	AWG12G	AWG12G: U1000, U1040
270000001	HwExecYigCal PLL 6GHz offset under 2048 vtune=xxxx	CLK12G	CLK12G:U3200, U3250, Y3280
270000002	HwExecYigCal PLL 6GHz offset underflow vtune=xxxx	CLK12G	CLK12G:U3200, U3250, Y3280
270000003	HwExecYigCal PLL 6GHz tuning underflow vtune=xxxx	CLK12G	CLK12G:U3200, U3250, Y3280
270000004	HwExecYigCal PLL 6GHz tuning underflow vtune=xxxx	CLK12G	CLK12G:U3200, U3250, Y3280
270000005	HwExecYigCal PLL 12GHz tuning over 4095 vtune=xxxx	CLK12G	CLK12G:U3200, U3250, Y3280
270000006	HwExecYigCal PLL 12GHz tuning overflow vtune=xxxx	CLK12G	CLK12G:U3200, U3250, Y3280
271000001	HwExecYigCal PLL 6GHz offset under 2048 vtune=xxxx	CLK12G	CLK12G: U3200, U3250, Y3280
271000002	HwExecYigCal PLL 6GHz offset underflow vtune=xxxx	CLK12G	CLK12G: U3200, U3250, Y3280
271000003	HwExecYigCal PLL 6GHz tuning underflow vtune=xxxx	CLK12G	CLK12G: U3200, U3250, Y3280
271000004	HwExecYigCal PLL 6GHz tuning underflow vtune=xxxx	CLK12G	CLK12G: U3200, U3250, Y3280
271000005	HwExecYigCal PLL 12GHz tuning over 4095 vtune=xxxx	CLK12G	CLK12G: U3200, U3250, Y3280
271000006	HwExecYigCal PLL 12GHz tuning overflow vtune=xxxx	CLK12G	CLK12G: U3200, U3250, Y3280
272000000	Clock Power CAL failed		
272000001	Clock Power CAL failed at 6 GHz		
272000002	Clock Power CAL failed at 12 GHz		
290000000	Marker Level Calibration has not been completed.	N/A	
290000001	Marker cross point calibration result exceeds limit.	OUT10G	OUT10G: U120, U170
290X00000	Marker Level Calibration has not been completed at CHX.	N/A	
290XY0001	Marker cross point calibration result exceeds limit at CHX, MARKER Y.	OUT10G, AWG12G	OUT10G: U120/170, U470/480, J100/110/150/170 AWG12G: J110A/111A/115A/ 116A/110B/111B/115B/116B
290XY0002	Marker cross point calibration couldn't be converged on -1.0V at CHX, MARKER Y.	OUT10G, AWG12G	OUT10G: U120/170, U470/480, J100/110/150/170 AWG12G: J110A/111A/115A/ 116A/110B/111B/115B/116B
291000000	Marker Level Calibration has not been completed.	N/A	
291000001	Marker cross point calibration result exceeds limit.	N/A	
291X00000	Marker Level Calibration has not been completed at CHX.	N/A	

Table 4-7: Calibration error codes (cont.)

Error code	Error log message	Possible defect on board	Note
291XY0001	Marker cross point calibration result exceeds limit at CHX, MARKER Y.	N/A	
291XY0002	Marker cross point calibration couldn't be converged on -1.0V at CHX, MARKER Y.	N/A	

Hardware Error

The following table lists the instrument hardware related errors.

Table 4-8: Hardware error codes

Error code	Error log message	Possible defect on board	Note
300000000	The system cannot find the device specified.	MIO	MIO: U100, U200, U220, Y230
300000001	The device is not ready.	N/A	Software
300000002	The AWG register access timeout period has expired.	MIO, AWG12G	MIO: U200, U300 AWG12G: U1000 MIO-AWG12G Cable
300000003	The time-out was generated while measuring data.	AWG12G	AWG12G: U1000
300000004	The timer for the trigger has stopped.	AWG12G	AWG12G: U1000
300000005	PLL doesn't lock.	AWG12G, CLK12G	AWG12G: U1000 CLK12G: U3200, U3250, Y3260...
300000006	AwgController DLL doesn't lock.	AWG12G	AWG12G: U1000
300000007	Output board access error Board=No No: Board number (Start with 0)	OUT10G	OUT10G: U500
300000008	Not enough storage is available to process.	N/A	Software
300000009	Calibration checksum data has an error.	MIO	MIO: U300, U390
300000010	Calibration version unmatched.	MIO	MIO: U300, U390
300000011	YIG tuning has an error.	CLK12G	CLK12G: U3200, U3250, Y3260...
300000012	The lpc busy timeout period has expired.	AWG12G	AWG12G: U1000
300000013	MemoryController DLL doesn't lock.	AWG12G	AWG12G: U1000, U400xx
300000014	MemoryController Dynamic Phase Shift - IPC error.	AWG12G	AWG12G: U1000, U400xx
300000015	MemoryController Dynamic Phase Shift - Waveform RAM error.	AWG12G	AWG12G: U1000, U400xx
300000016	MemoryController Dynamic Phase Shift - System Clock error.	AWG12G	AWG12G: U1000, U400xx
300000017	The Diag busy timeout period has expired.	AWG12G	AWG12G: U1000, U400xx
300000019	AWG12G board Calibration checksum data has an error.	AWG12G	AWG12G: U1090 Software
300000020	AWG12G board Calibration version unmatched.	AWG12G	AWG12G: U1090 Software
300000021	Read Error on Event Input Register.	AWG12G	AWG12G: U1000
300000022	Read Error on Trigger Input Register.	AWG12G	AWG12G: U1000
300000023	Read Error on Trigger Timer Register.	AWG12G	AWG12G: U1000
300000100	Access to EEPROM failed on MIO board.	MIO	MIO: U300, U390
300000101	Access to EEPROM failed on OUTPUT board.	OUT10G	OUT10G: U500, U550
300000102	The relay count is invalid. Board-1	OUT10G	OUT10G: U500, U550
300000103	The relay count is invalid. Board-2	OUT10G	OUT10G: U500, U550

Table 4-8: Hardware error codes (cont.)

Error code	Error log message	Possible defect on board	Note
300000104	Access to EEPROM failed on AWG board.	AWG12G	AWG12G: U1090
300000200	The download (MIO-INIT) timeout period has expired.	MIO	MIO: U200, U300
300000201	The download (MIO-INIT) timeout period has expired.	MIO	MIO: U200, U300
300000202	The download (MIO-DONE) timeout period has expired.	MIO	MIO: U200, U300
300000203	The download (MIO) timeout period has expired.	MIO	MIO: U200, U300
300000204	The system cannot find the file specified.(PLD140b.Bit)	N/A	Software
300000205	An attempt was made to load a program with an incorrect format.(PLD131.Bit)	N/A	Software
300000206	The download(AwgController-INIT) timeout period has expired.	MIO, AWG12G	MIO: U300 AWG12G: U1000 MIO-AWG12G Cable
300000207	The download(AwgController-INIT) timeout period has expired.	MIO, AWG12G	MIO: U300 AWG12G: U1000
300000208	The download(AwgController-DONE) timeout period has expired.	MIO, AWG12G	MIO: U300 AWG12G: U1000 MIO-AWG12G Cable
300000209	The download (AwgController) timeout period has expired.	MIO, AWG12G	MIO: U300 AWG12G: U1000 MIO-AWG12G Cable
300000210	The system cannot find the file specified.(PLD231.Bit)	N/A	Software/Disk Drive
300000211	An attempt was made to load a program with an incorrect format.(PLD231.Bit)	N/A	Software/Disk Drive
300000212	The download (MemoryController-INIT) timeout period has expired.	MIO, AWG12G	MIO: U300 AWG12G: U1000, U400xx
300000213	The download (MemoryController-INIT) timeout period has expired.	MIO, AWG12G	MIO: U300 AWG12G: U1000, U400xx
300000214	The download (MemoryController-DONE) timeout period has expired.	MIO, AWG12G	MIO: U300 AWG12G: U1000, U400xx
300000215	The download (MemoryController) timeout period has expired.	MIO, AWG12G	MIO: U300 AWG12G: U1000, U400xx
300000216	The system cannot find the file specified.(PLD230b.Bit)	N/A	Software/Disk Drive
300000217	An attempt was made to load a program with an incorrect format.(PLD230b.Bit)	N/A	Software/Disk Drive
300000218	The DCM timeout period has expired.	MIO	MIO: U300
300000219	The LOCKED timeout period has expired.	MIO	MIO: U300
300000220	A PLD231.Bit file is old version.	N/A	Software/Disk Drive
300000221	A PLD230.Bit file is old version.	N/A	Software/Disk Drive

Table 4-8: Hardware error codes (cont.)

Error code	Error log message	Possible defect on board	Note
310000000	The parameter is incorrect.	N/A	Software/Disk Drive
390000001	The calibration data is invalid. The default value is used.	N/A	Not a defect.
390000002	The instrument started with Manufacturing mode.	N/A	Not a defect.
390000003	The calibration data is invalid. The default value is used.	N/A	Not a defect.

After Repair

After you replace a module, follow the instructions about adjustment and performance verification. This is essential to ensure proper instrument performance. (See page 3-1, *Adjustment After Repair*.)

Returning the Instrument for Service

When repacking the instrument for shipment, use the original packaging material. If it is unavailable or unfit for use, contact your local Tektronix representative to obtain new packaging.

Seal the shipping carton with an industrial stapler or strapping tape.

Before returning the instrument for service, contact the Service Center to get an RMA (return material authorization) number, and any return or shipping information you may need.

If the instrument is being shipped to a Tektronix Service Center, enclose the following information:

- The RMA number.
- The owner's address.
- Name and phone number of a contact person.
- Type and serial number of the instrument.
- Reason for returning.
- A complete description of the required service.

Mark the address of the Tektronix Service Center and the return address on the shipping carton in two prominent locations. See www.tektronix.com/service to find a Tektronix Service Center near you.

Replaceable Parts

Replaceable Parts

This section contains a list of the replaceable modules for the AWG7000 Series Arbitrary Waveform Generators. Use this list to identify and order replacement parts.

Parts Ordering Information

Replacement parts are available through your local Tektronix field office or representative.

Changes to Tektronix instruments are sometimes made to accommodate improved components as they become available and to give you the benefit of the latest circuit improvements. Therefore, when ordering parts, it is important to include the following information in your order.

- Part number
- Instrument type or model number
- Instrument serial number
- Instrument modification number, if applicable

If you order a part that has been replaced with a different or improved part, your local Tektronix field office or representative will contact you concerning any change in part number.

Part Number Revision Level

Tektronix part numbers contain two digits that show the revision level of the part. For most parts in this manual, you will find the letters XX in place of the revision level number.



When you order parts, Tektronix will provide you with the most current part for your product type, serial number, and modification (if applicable). At the time of your order, Tektronix will determine the part number revision level needed for your product, based on the information you provide.

Module Servicing Modules can be serviced by selecting one of the following three options. Contact your local Tektronix service center or representative for repair assistance.

Module Exchange. In some cases, you may exchange your module for a remanufactured module. These modules cost significantly less than new modules and meet the same factory specifications. For more information about the module exchange program, call 1-800-833-9200. Outside North America, contact a Tektronix sales office or distributor; see the Tektronix Web site (www.tektronix.com) for a list of offices.

Module Repair and Return. You may ship your module to us for repair, after which we will return it to you.

New Modules. You may purchase replacement modules in the same way as other replacement parts.

Using the Replaceable Parts List

This section contains a list of the replaceable mechanical and/or electrical components. Use this list to identify and order replacement parts. The following table describes each column in the parts list.

Parts List Column Descriptions

Column	Column name	Description
1	Figure & Index Number	Items in this section are referenced by component number.
2	Tektronix Part Number	Use this part number when ordering replacement parts from Tektronix.
3 and 4	Serial Number	Column three indicates the serial number at which the part was first effective. Column four indicates the serial number at which the part was discontinued. No entries indicates the part is good for all serial numbers.
5	Qty	This indicates the quantity of parts used.
6	Name & Description	An item name is separated from the description by a colon (:). Because of space limitations, an item name may sometimes appear as incomplete. Use the U.S. Federal Catalog handbook H6-1 for further item name identification.

Abbreviations Abbreviations conform to American National Standard ANSI Y1.1-1972.

Table 5-1: Replaceable parts list – cosmetics

Fig. & index number	Tektronix part number	Serial no. effective	Serial no. discont'd	Qty	Name & description
5-1-					COSMETICS
-1	335-2518-00			1	MARKER, LABEL IDENTIFICATION; AWG7082C, 8GS/S STANDARD
	335-2519-00			1	MARKER, LABEL IDENTIFICATION; AWG7122C, 12GS/S STANDARD
	335-2284-00			1	MARKER, LABEL, IDENTIFICATION; AWG7122C, 24GS/S
	335-2285-00			1	MARKER, LABEL IDENTIFICATION; AWG7082C, 16GS/S
	335-1974-00			1	MARKER; LABEL, IDENTIFICATION; AWG7121B
	335-1975-00			1	MARKER; LABEL, IDENTIFICATION; AWG7122B
	335-1976-00			1	MARKER; LABEL, IDENTIFICATION; AWG7061B
	335-1977-00			1	MARKER; LABEL, IDENTIFICATION; AWG7062B
-2	101-0176-01			1	TRIM, RING; FRONT, SAFETY CONTROLLED
-3	101-0177-00			1	TRIM, ACQUISITION INSERT, HPI. SMA SONNECTOR
-4	101-0174-00			1	TRIM, DVD
-5	260-2837-00			1	KEYPAD; FOR POWER BUTTON TOP, CLEAR, SILICONE RUBBER W/ CONDUCTIVE SILICONE RUBBER TIP, SNAP ACTION, TRAVEL 0.045 IN, 200 GRAM, HYSTERESIS GT 35%, W TOP COAT
-6	211-1050-00			4	SCREW, MACHINE; 6-32 X 0.312 L, PNH, STL CAD PLT, T15
-7	200-4994-01			1	COVER, COSMETIC, TOP
-8	211-1050-00			4	SCREW, MACHINE; 6-32 X 0.312 L, PNH, STL CAD PLT, T15
-9	355-0298-00			4	STUD, SNAP; 0.570 DIA, 0.165 THK, STAINLESS STEEL
-10	211-0732-01			4	SCR, ASSEM WSHR; 6-32 X 0.75, PNH, STL, CD PL, TORX T15
-11	348-1861-00			4	FOOT; REAR, ASSY. W/ CORD WRAP, THERMOPLASTIC, SRY
-12	407-4887-00			1	BRACKET; HANDLE BASE, PC/ABS ALLOY, BAYER BAYBLEND FR-110, TEK BLUE, SAFETY CONTROLLED
-13	212-0232-00			2	SCREW, MACHINE; 8-32 X 1.125L, PNH, STL, BLACK ZINK SPEC #ASTM B633 TYPE II, T-20, TORX DRIVE
-14	367-0528-00			1	HANDLE, CARRYING; DUAL DUROMETER MOLDED, POLYPROPYLENE, VINYL GRIP SECTION, SAFETY CONTROLLED
-15	348-1515-00			2	FEET, CABINET; BLACK, SET OF 4 FEET
-16	200-4995-01			1	COVER, COSMETIC, BOTTOM
-17	211-1050-00			3	SCREW, MACHINE; 6-32 X 0.312 L, PNH, STL CAD PLT, T15
-18	335-1577-00			1	MARKER, IDENTIFICATION, FRONT PANEL, 2 CHANNEL, SAFETY CONTROLLED
	335-1578-00			1	MARKER, IDENTIFICATION, FRONT PANEL, 1 CHANNEL, SAFETY CONTROLLED (AWG7000B SERIES)
-19	335-1581-00			1	MARKER, IDENTIFICATION, SIGNAL INPUT/OUTPUT, SMA, 2 CHANNEL, SAFETY CONTROLLED
	335-1582-00			1	MARKER, IDENTIFICATION, SIGNAL INPUT/OUTPUT, SMA, 2 CHANNEL, INTERLEAVE, SAFETY CONTROLLED (OPTION 06)
	335-1583-00			1	MARKER, IDENTIFICATION, SIGNAL INPUT/OUTPUT, SMA, 1 CHANNEL, SAFETY CONTROLLED (AWG7000B SERIES)
-20	366-0841-00			1	KNOB, CAP; 1.380 DIA, PC/ABS, SILVER GRAY

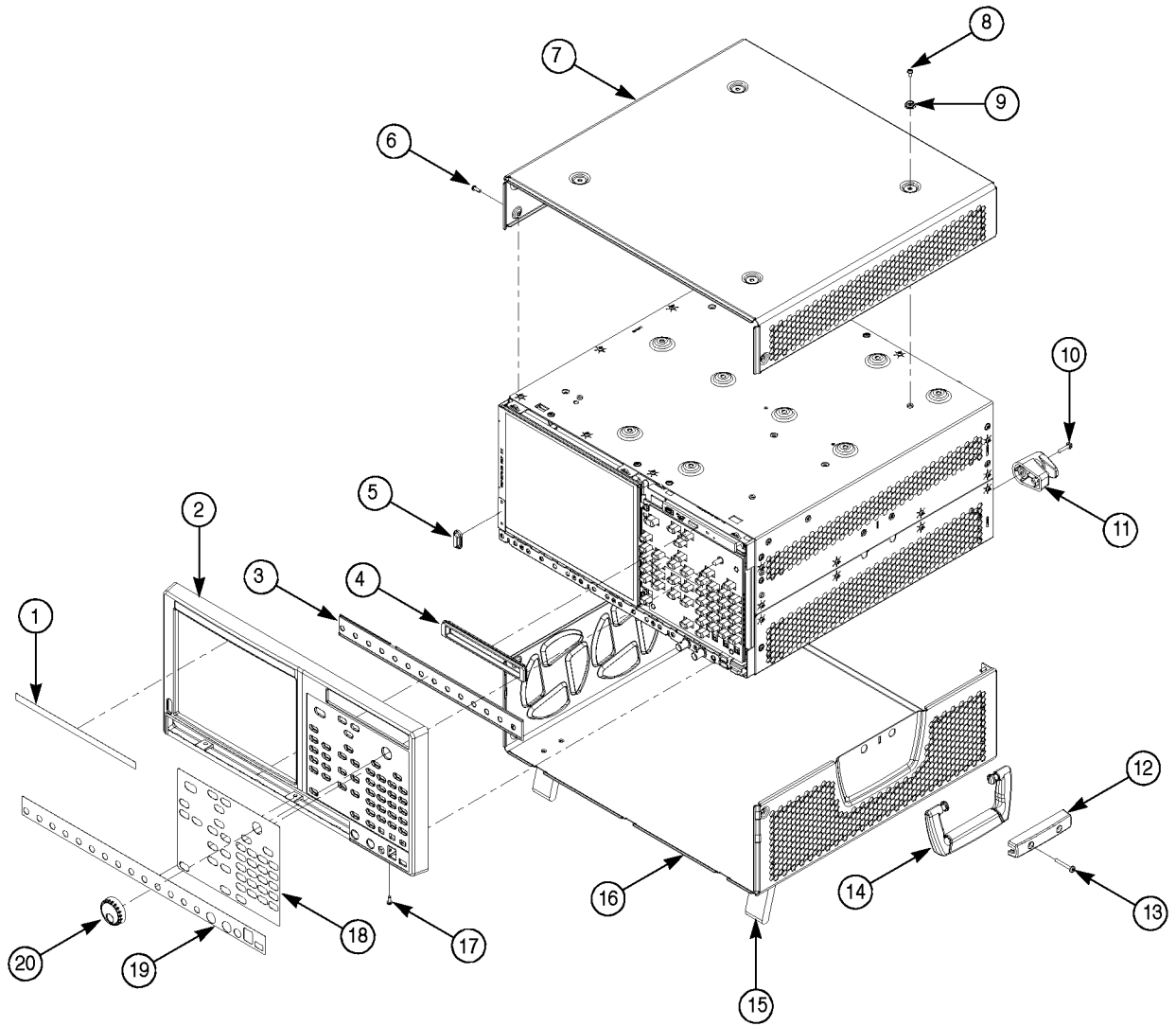

Figure 5-1: Cosmetics

Table 5-2: Replaceable parts list – EMI covers

Fig. & index number	Tektronix part number	Serial no. effective	Serial no. discont'd	Qty	Name & description
5-2-					EMI COVERS
-1	200-4992-01			1	COVER, EMI, TOP (AWG7000B)
	200-5156-00			1	COVER, EMI, TOP (AWG7000C)
-2	200-5034-01			1	COVER, EMI, BOTTOM
-3	211-1050-00			26	SCREW,MACHINE; 6-32 X 0.312 L,PNH,STL CAD PLT,T15

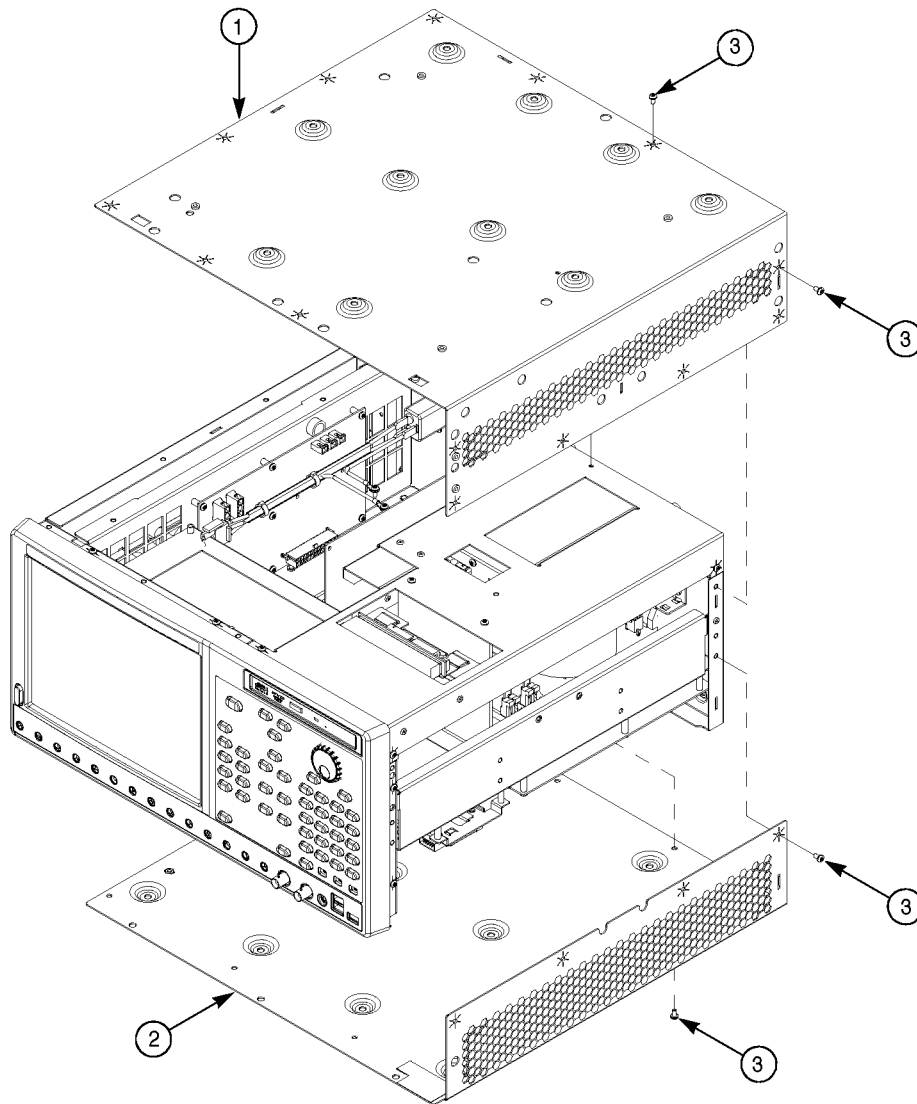
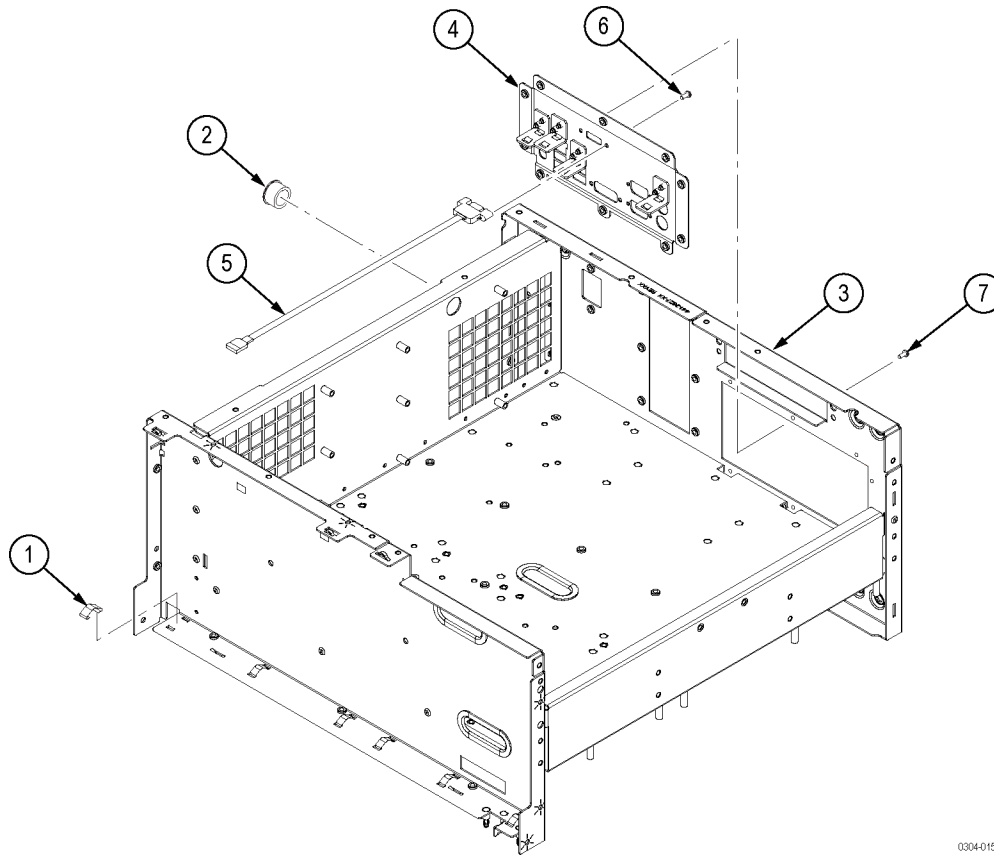

Figure 5-2: EMI Covers

Table 5-3: Replaceable parts list – AWG7000C Series chassis assembly

Fig. & index number	Tektronix part number	Serial no. effective	Serial no. discont'd	Qty	Name & description
5-3-					CHASSIS ASSEMBLY
-1	131-6417-00			6	CONTACT,ELEC; GROUNDING,0.600 L X 0.250 W X 0.220 D, ELECTROLESS NICKEL PLATE
-2	348-0966-00			1	GROMMET,PLASTIC;BLACK,ROUND,0.625 ID
-3	441-2630-00			1	CHASSIS, MAIN; ASSEMBLY (INCLUDES #4 AND #7)
-4	441-2585-00			1	BRACKET, IO M-BOARD, SAFETY CONTROLLED
-5	174-5763-00			1	CABLE, SATA TO E-SATA, DATA ONLY
-6	211-0294-00			2	SCREW, MACHINE; M3 X 0.5 X 10MM, PNH, STEEL, ZINC PLATED, T-10 TORX DR
-7	211-1050-00			10	SCREW, MACHINE; 6-32 X 0.312 L, PNH, STEEL, ZINC FINISH, T15



0304-015

Figure 5-3: AWG7000C Series chassis assembly

Table 5-4: Replaceable parts list – AWG7000B Series chassis assembly

Fig. & index number	Tektronix part number	Serial no. effective	Serial no. discont'd	Qty	Name & description
5-4-					CHASSIS ASSEMBLY
-1	131-6417-00			6	CONTACT,ELEC; GROUNDING,0.600 L X 0.250 W X 0.220 D, ELECTROLESS NICKEL PLATE
-2	348-0966-00			1	GROMMET,PLASTIC;BLACK,ROUND,0.625 ID
-3	441-2536-00			1	CHASSIS, MAIN; ASSEMBLY

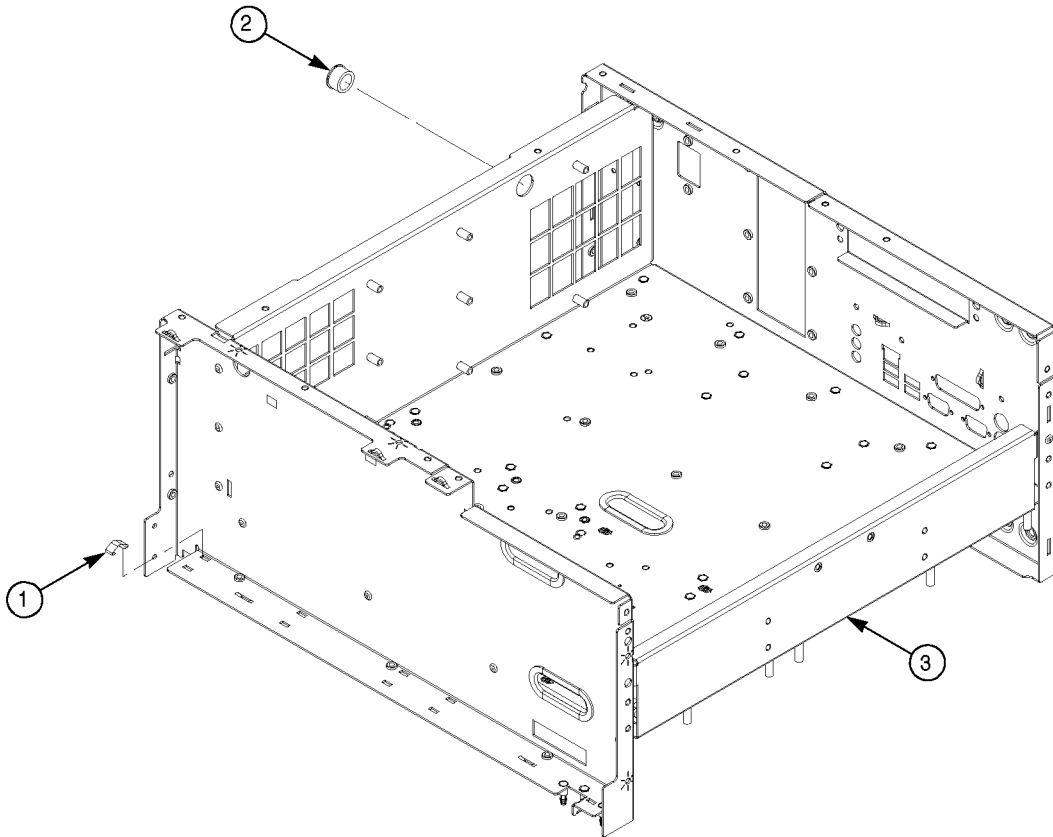
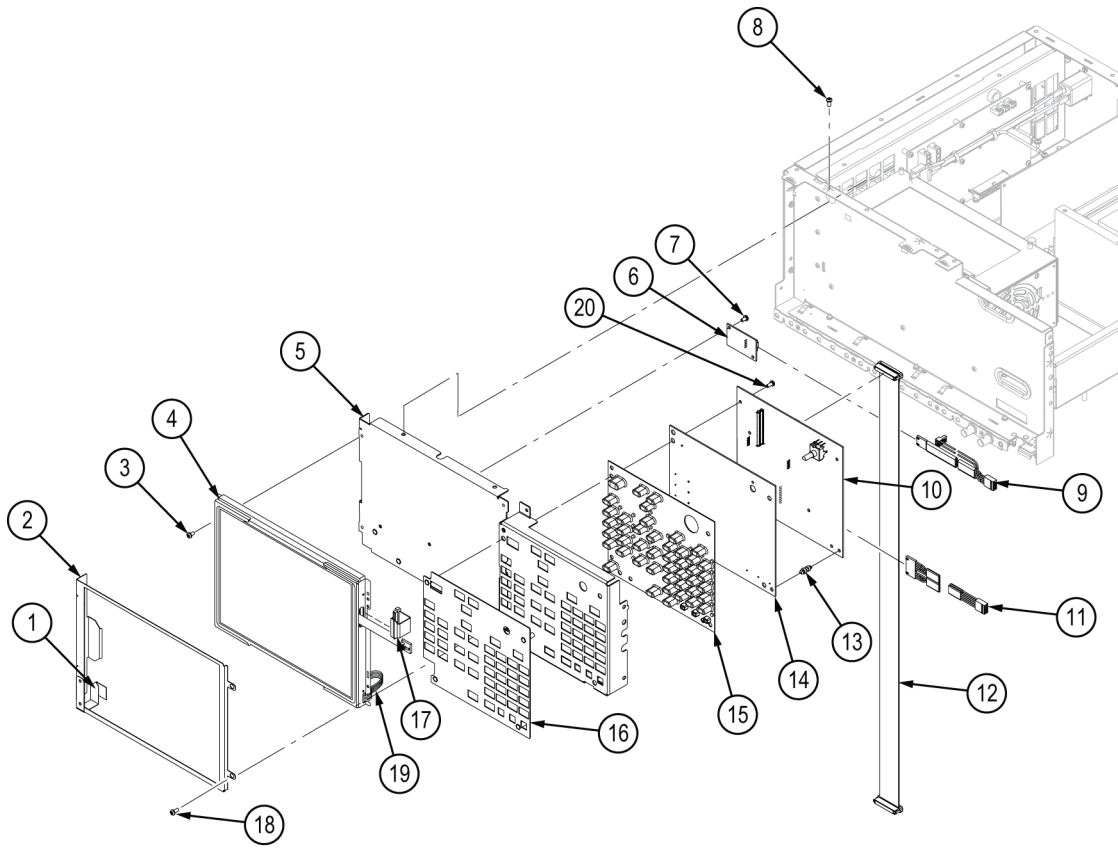

Figure 5-4: AWG7000B Series chassis assembly

Table 5-5: Replaceable parts list – AWG7000C Series front-panel assembly

Fig. & index number	Tektronix part number	Serial no. effective	Serial no. dis-cont'd	Qty	Name & description
5-5-					FRONT-PANEL ASSEMBLY
-1	259-0193-00			1	FLEX CIRCUIT; ON/STAND BY SWITCH
-2	407-5537-00			1	BRACKET; TOUCH SCREEN
-3	211-1236-00			4	SCREW, MACHINE; W/HEAVY PATCH THREADLOCKING MATERIAL; 4-40 X 0.25, PNH, 410 SS PASSIVATEDT, T10
-4	650-5362-00			1	TOUCH SCREEN ASSEMBLY
-5	407-5536-00			1	BRACKET; DISPLAY, FRONT PANEL, SAFETY CONTROLLED
-6	878-0257-00			1	CIRCUIT BOARD ASSY; FSW, FRONT PANEL SWITCH
-7	211-1050-00			2	SCREW,MACHINE; 6-32 X 0.312 L,PNH,STL CAD PLT,T15
-8	211-1050-00			7	SCREW,MACHINE; 6-32 X 0.312 L,PNH,STL CAD PLT,T15
-9	174-5256-00			1	CABLE ASSY ELEC: 7P,0.1,1.18IN L,AWG 24,UL1061, 87456-5, 103958-4, TYCO,3-640441-3,AMP,FOR PWR SW & LEDS
-10	679-6492-00			1	CIRCUIT BD ASSY: LEDA , LED ADAPTER
-11	174-5254-00			1	CABLE ASSY ELEC: 2X5P,0.1,19.7 IN L,AWG 24,W/KEYING PLUG, 87456-5, 87809-1 CONTACT,AMP
-12	174-5161-00			1	CABLE ASSY;DISPLAY ADAPTER TO PCI BOARD
-13	129-1631-00			2	LOCKING STANDOFF; NATURAL 3/8 IN. SPACER,NYLON 66,1M/BAG TOP/BOTTOM HOLES: 156 IN. /187 IN. TOP/BOTTOM PANEL THK: .062 IN
-14	679-6063-03			1	CIRCUIT BOARD ASSY;FRONTPANEL
-15	260-2819-00			1	SWITCH,KEYPAD; FRONT PANEL
-16	407-5176-00			1	BRACKET;TRIM,FRONTPANEL,SHEET METAL,SAFETY CONTROLLED
-17	174-5160-00			1	CABLE ASSY;DISPLAY ADAPTER TO DISPLAY; SAFETY CONTROLLED
-18	211-1050-00			2	SCREW,MACHINE; 6-32 X 0.312 L,PNH,STL CAD PLT,T15
-19	174-5807-00			1	CABLE, ASSEMBLY (DISPLAY BACKLIGHT)
-20	211-1050-00			4	SCREW,MACHINE; 6-32 X 0.312 L,PNH,STL CAD PLT,T15



0304-006

Figure 5-5: AWG7000C Series front-panel assembly

Table 5-6: Replaceable parts list – AWG7000B Series front-panel assembly

Fig. & index number	Tektronix part number	Serial no. effective	Serial no. discontinued	Qty	Name & description
5-6-					FRONT-PANEL ASSEMBLY
-1	065-0762-01			1	TOUCH SCREEN ASSEMBLY
-2	211-1050-00			4	SCREW,MACHINE; 6-32 X 0.312 L,PNH,STL CAD PLT,T15
-3	119-6813-00			1	DISPLAY 10.4 INCH NL10276BC24-13
-4	361-1836-00			2	SPACER,PLATE; LEXAN,TOUCH SCREEN,W/ADHESIVE
-5	407-5173-01			1	BRACKET;DISPLAY
-6	119-6806-00			1	POWER SUPPLY;INVERTER
-7	211-0069-00			2	SCREW,MACHINE; 2-56 X 0.125,PNH,STL CR PL,POZ
-8	174-4794-00			1	CA ASSY; DISPLAY ADAPTER TO INVERTOR,SAFETY CONTROLLED
-9	679-6151-01			1	CIRCUIT BOARD ASSY;FSW,FRONT PANEL SWITCH
-10	211-1050-00			2	SCREW,MACHINE; 6-32 X 0.312 L,PNH,STL CAD PLT,T15
-11	211-1050-00			7	SCREW,MACHINE; 6-32 X 0.312 L,PNH,STL CAD PLT,T15
-12	174-5256-00			1	CABLE ASSY ELEC: 7P,0.1,1.18IN L,AWG 24,UL1061,87456-5, 103958-4, TYCO,3-640441-3,AMP,FOR PWR SW & LEDS
-13	211-1050-00			4	SCREW,MACHINE; 6-32 X 0.312 L,PNH,STL CAD PLT,T15
-14	679-6098-02			1	CIRCUIT BOARD ASSY:LCDA,LCD ADAPTER
-15	174-5254-00			1	CABLE ASSY ELEC: 2X5P,0.1,19.7 IN L,AWG 24,W/KEYING PLUG,87456-5, 87809-1 CONTACT,AMP
-16	174-5161-00			1	CABLE ASSY;DISPLAY ADAPTER TO PCI BOARD
-17	129-1631-00			2	LOCKING STANDOFF; NATURAL 3/8 IN. SPACER,NYLON 66, 1M/BAG TOP/BOTTOM HOLES: 156 IN. /.187 IN. TOP/BOTTOM PANEL THK: .062 IN.;
-18	679-6063-03			1	CIRCUIT BOARD ASSY;FRONTPANEL
-19	260-2819-00			1	SWITCH,KEYPAD; FRONT PANEL 4CH
-20	407-5176-00			1	BRACKET;TRIM,FRONTPANEL,SHEET METAL,SAFETY CONTROLLED
-21	174-4791-00			1	CA ASSY; DISPLAY ADAPTER TO XGA DISPLAY,SAFETY CONTROLLED
-22	211-1050-00			2	SCREW,MACHINE; 6-32 X 0.312 L,PNH,STL CAD PLT,T15

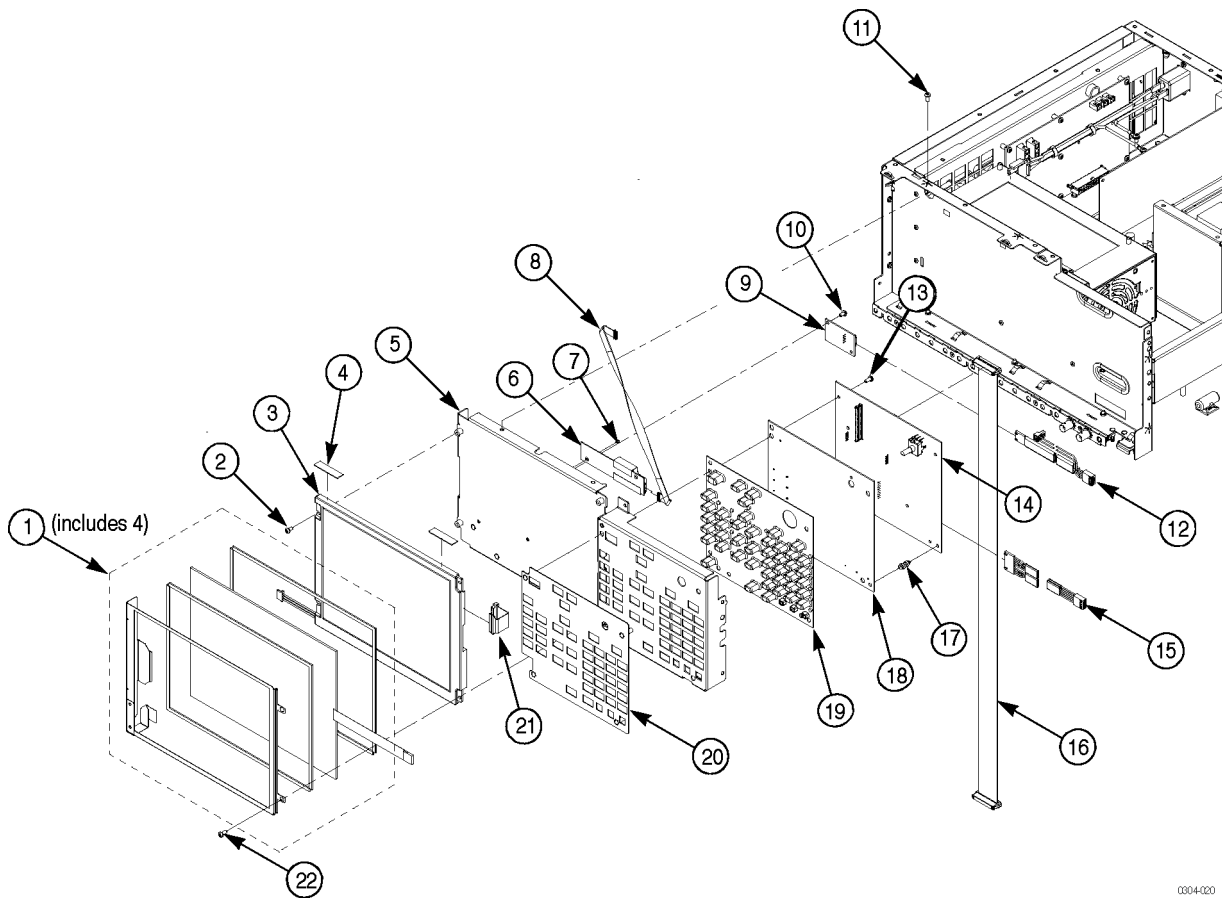

0004-020

Figure 5-6: AWG7000B Series front-panel assembly

Table 5-7: Replaceable parts list – AWG7000C Series drive modules

Fig. & index number	Tektronix part number	Serial no. effective	Serial no. dis-cont'd	Qty	Name & description
5-7-					DRIVE MODULE
-1	407-5156-00			1	BRACKET,DVD-CD/RW;ADAPTER FOR DVD-CD/RW SLIMLINE
-2	211-1050-00			2	SCREW,MACHINE; 6-32 X 0.312 L,PNH,STL CAD PLT,T15
-3	211-0950-00			4	SCREW,MACHINE; M2X.4X3L,PHL, PNH, STL NI PL
-4	119-7473-00			1	DISK DRIVE; OPTICAL, CD-RW/DVD ROM OR COMBO, SATA, DW224SV93;SAFETY CONTROLLED
-5	174-5650-00			1	CABLE, SATA-DVD, DATA AND POWER, SAFETY CONTROLLED
-6	441-2474-03			1	CHASSIS;DRIVE BAY;METAL
-7	211-1050-00			7	SCREW,MACHINE; 6-32 X 0.312 L,PNH,STL CAD PLT,T15
-8	174-5349-00			1	CABLE ASSY; SATA COMBO, HARD DRIVE CABLE WITH LATCH
-9	407-5337-00			1	BRACKET,RHDD; SATA COMBO CABLE RETENTION
-10	211-1050-00			2	SCREW,MACHINE; 6-32 X 0.312 L,PNH,STL CAD PLT,T15
-11	650-5336-00			1	ACCESSORY KIT; REMOVABLE HARD DRIVE ASSEMBLY, V4.0 PROGRAMMED FW
-12	351-1118-00			1	GUIDE,HD; REMOVABLE,3.5 INCH HARD DISK DRIVE, SAFETY CONTROLLED
-13	211-1174-00			4	SCREW,MACHINE; W/HEAVY PATCH THREADLOCKING MATERIAL; 6-32 X 0.312 L,PNH,STL CAD PLT,T15
-14	407-5331-00			1	BRACKET, ASSEMBLY, REMOVABLE 3.5 INCH HARD DRIVE CARTRIDGE
-15	211-0734-00			4	SCREW,MACHINE; 6-32 X 0.250,FLH100,STL,CDPL,T-10 TORX DR

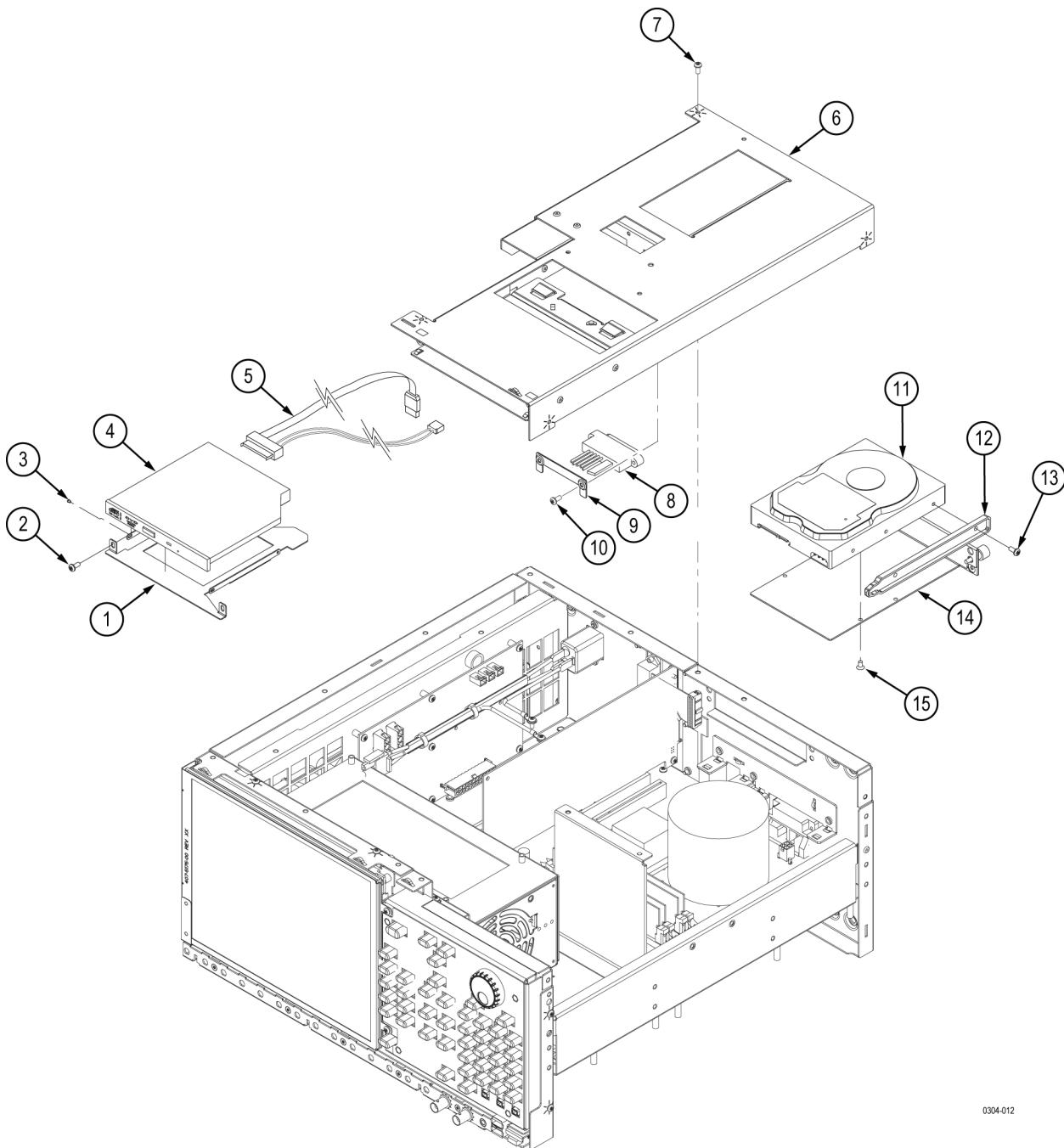

0304-012

Figure 5-7: AWG7000C Series drive modules

Table 5-8: Replaceable parts list – AWG7000B Series drive module

Fig. & index number	Tektronix part number	Serial no. effective	Serial no. discont'd	Qty	Name & description
5-8-					DRIVE MODULE
-1	407-5365-00			1	BRACKET, REINFORCEMENT; MIO BOARD HOLDER WHEN INSTALLED
-2	211-1050-00			2	SCREW,MACHINE; 6-32 X 0.312 L,PNH,STL CAD PLT,T15
-3	407-5156-00			1	BRACKET,DVD-CD/RW;ADAPTER FOR DVD-CD/RW SLIMLINE
-4	211-1050-00			5	SCREW,MACHINE; 6-32 X 0.312 L,PNH,STL CAD PLT,T15
-5	211-0950-00			4	SCREW,MACHINE; M2X.4X3L,PHL, PNH, STL NI PL
-6	119-7196-00			1	DISK DRIVE; OPTICAL; CDRW/DVDROM / TEAC
-7	129-1618-00			1	SPACER; DVD-CD/RW SLIMLINE DRIVE ADAPTER,PLASTIC
-8	679-5915-00			1	CKT BD SUBASSY; DVD-CD/RW ADAPTER,UNTESTED, 389-3689-00 WIRED
-9	211-0888-00			2	SCREW,METRIC; M-2 X 0.4 X 6MM,PHILLIPS PAN,ZINC PLATED,PHIL PAN HEAD,STEEL
-10	174-4671-00			1	CA ASSY,SP; ULTRA DMA/ATA HARD DISK DRIVE,IDE,18.0 L,SAFETY CONTROLLED
-11	211-1050-00			8	SCREW,MACHINE; 6-32 X 0.312 L,PNH,STL CAD PLT,T15
-12	441-2474-03			1	CHASSIS;DRIVE BAY;METAL
-13	407-5337-00			1	BRACKET,RHDD; SATA COMBO CABLE,3.5 INCH REMOVABLE HARD DISK DRIVE RECEPTACLE
-14	211-1050-00			5	SCREW,MACHINE; 6-32 X 0.312 L,PNH,STL CAD PLT,T15
-15	174-5169-00			1	CABLE ASSY; SATA COMBO,HARD DRIVE CABLE
-16	119-7189-01	B010000	B019999	1	DISK DRIVE,HARD; 80GB,3.5 INCH,7200 RPM,SATA II 3.0 GB/S INTERFACE, HITACHI P/N HDS728080PLA380,PATHFINDER 0A30358, SAFETY CONTROLLED
	650-5282-00	B020000		1	DISK DRIVE ASSEMBLY, PROGRAMMED; DISK DRIVE ASSEMBLY, V3.4 PROGRAMMED FW; NEW LCD BOARD COMPATIBLE (6177024XX), GREATER THAN THE S/N BREAK B020000
-17	351-1118-00			1	GUIDE,HD; REMOVABLE,3.5 INCH HARD DISK DRIVE, SAFETY CONTROLLED
-18	211-1174-00			4	SCREW,MACHINE; W/HEAVY PATCH THREADLOCKING MATERIAL; 6-32 X 0.312 L,PNH,STL CAD PLT,T15
-19	407-5172-00			1	BRACKET, ASSEMBLY, REMOVABLE 3.5 INCH HARD DRIVE CARTRIDGE, AWG7000 SERIES
-20	211-0734-00			4	SCREW,MACHINE; 6-32 X 0.250,FLH100,STL,CDPL,T-10 TORX DR
-21	174-5017-00			1	CABLE ASSEMBLY; DVD POWER, SAFETY CONTROLLED
-22	065-0811-01			1	ACCESSORY KIT; REMOVABLE HDD ASSY; UNPROGRAMMED HARD DRIVE 119718901 W/PACKAGING

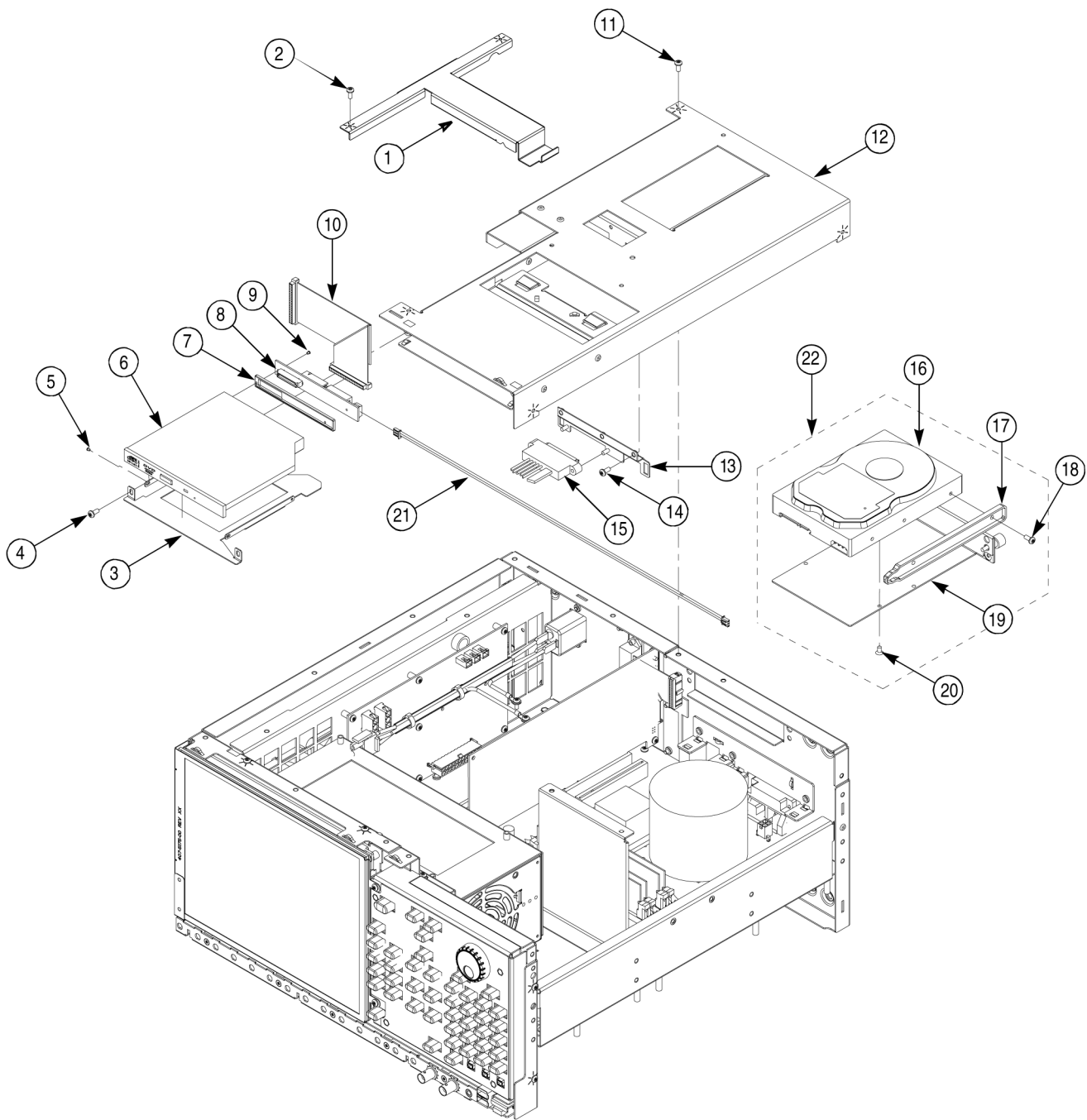

Figure 5-8: AWG7000B Series drive module

Table 5-9: Replaceable parts list – AWG700C Series Processor module

Fig. & index number	Tektronix part number	Serial no. effective	Serial no. discontinued	Qty	Name & description
5-9-					PROCESSOR MODULE
-1	407-5195-01			1	BRACKET;DRIVE BAY UNIT
-2	211-1050-00			10	SCREW,MACHINE; 6-32 X 0.312 L,PNH,STL CAD PLT,T15
-3	343-1627-00			1	CABLE,CLAMP; 0.5H X 2.98L,0.625 W,NYLON 6-6,ADHESIVE,COVER 343-1636-00
-4	343-1636-00			1	CLAMP, COVER; FLT CABLE ROUTING CLAMP, 343-1627-00 BASE
-5	346-0128-00			2	STRAP,TIEDOWN;8.0 L X 0.1 W,NYLON
-6	343-1701-00			2	CLAMP,CABLE; WITH ADHESIVE BACK
-7	211-1050-00			8	SCREW,MACHINE; 6-32 X 0.312 L,PNH,STL CAD PLT,T15
-8	039-0188-00			1	COMPUTER BOARD;ADVANTECH, MICROATX, LGA 775 CORE 2 DUO, DDR2, PCI-E X4, DUAL CH LVDS, DVI-I, SINGLE GBE LAN; ADVANTECH AIMB-566, SAFETY CONTROLLED
-9	167-1493-00			2	IC, MEMORY;256MBIT X 64, 2GB DDR2 1.8V, 6-6-6, 800 MT/S; MT16HTF25664AY-800, DIMM240, PC6400
-10	119-7632-00			1	FAN, TUBEAXIAL; 12VDC, 0.40A, 4.80W, 2500RPM, 100.6CFM, 120MM, W/LEADS; SAFETY CONTROLLED
-11	167-1348-00			1	PROCESSOR; INTEL CORE 2 DUO, 3.0 GHZ, WOLFDAL, E8400; 65W; BUS SPD 1333MHZ; FC-LGA775 PKG, W/O FAN AND HEATSINK
-12	342-1153-00			1	INSULATOR; PLATE,MOTHER BOARD,0.04 POLYCARBONATE, TAPPEN
-13	441-2626-00			1	CHASSIS,TRAY,PROCESSOR, SAFETY CONTROLLED
-14	214-3903-00			6	SCREW,JACK; 4-40 X 0.312 LONG,0.188 H HEX HEAD STAND OFF, 4-40 INT THD, X 0.312 THD EXT 4-40

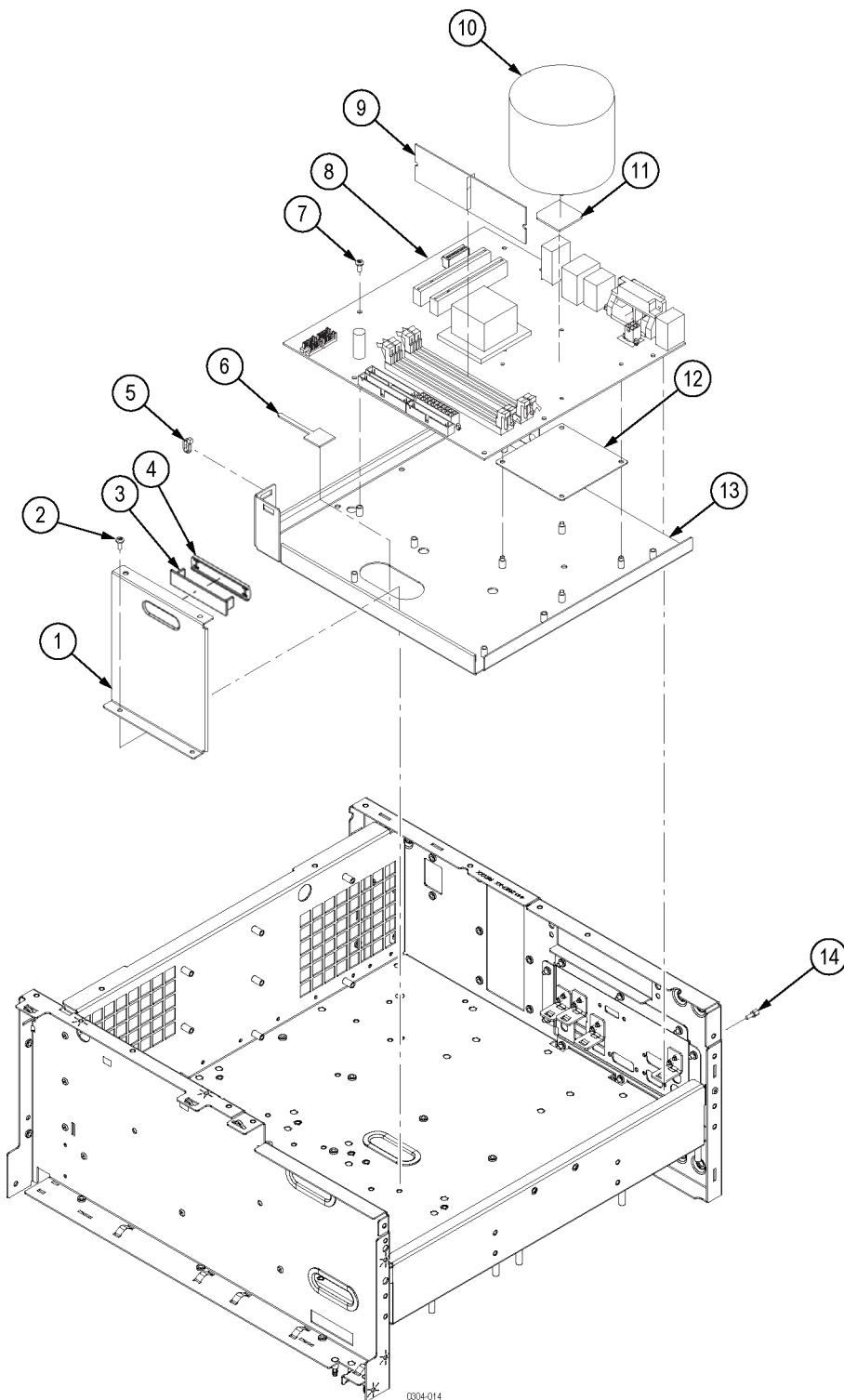

Figure 5-9: AWG7000C Series Processor module

Table 5-10: Replaceable parts list – AWG7000B Series processor module

Fig. & index number	Tektronix part number	Serial no. effective	Serial no. discontinued	Qty	Name & description
5-10-					PROCESSOR MODULE
-1	407-5195-01			1	BRACKET;DRIVE BAY UNIT
-2	211-1050-00			10	SCREW,MACHINE; 6-32 X 0.312 L,PNH,STL CAD PLT,T15
-3	346-0128-00			2	STRAP,TIEDOWN;8.0 L X 0.1 W,NYLON
-4	343-1701-00			2	CLAMP,CABLE; WITH ADHESIVE BACK
-5	211-1050-00			8	SCREW,MACHINE; 6-32 X 0.312 L,PNH,STL CAD PLT,T15
-6	167-1048-00			1	IC, MEMORY;128M X 64, 1GB DDR2 1.8V, 3-3-3, 667 MHZ;MT8HTF12864AY-667E1, DIMM240, DS1
	167-1515-00			1	IC MEMORY, DRAM MODULE; 2GB DDR2 PC5300
-7	119-7333-00			1	P4 LGA775 FAN-SINK-BRACKET FROM AVC
-8	167-0710-00			1	PROCESSOR; CELERON D, 2.93 GHZ,LEAD-FREE, 1.287V TO 1.4V CORE,84W,BUS SPD 533MHZ,FC-LGA4 775 PKG, W/O FAN and HEATSINK,HH80547RE077CN,INTEL
-9	335-0577-00			1	MARKER,IDENT;MKD MAC ADDRESS LABEL
-10	342-1153-00			1	INSULATOR; PLATE,MOTHER BOARD,0.04 POLYCARBONATE, TAPPEN
-11	441-2542-00			1	CHASSIS,TRAY,PROCESSOR,TAPPEN, SAFETY CONTROLLED
-12	407-5320-00			1	BRACKET,CONN; AL,0.063 THICK,W/131641700 EMI CLIPS
-13	211-1050-00			3	SCREW,MACHINE; 6-32 X 0.312 L,PNH,STL CAD PLT,T15
-14	214-3903-00			6	SCREW,JACK; 4-40 X 0.312 LONG,0.188 H HEX HEAD STAND OFF, 4-40 INT THD, X 0.312 THD EXT 4-40
-15	065-0813-02	B010000	B019999	1	MODULE; PROCESSOR
	650-5305-00	B020000		1	MODULE; PROCESSOR, REPROGRAMMED BIOS TO 62X1182C

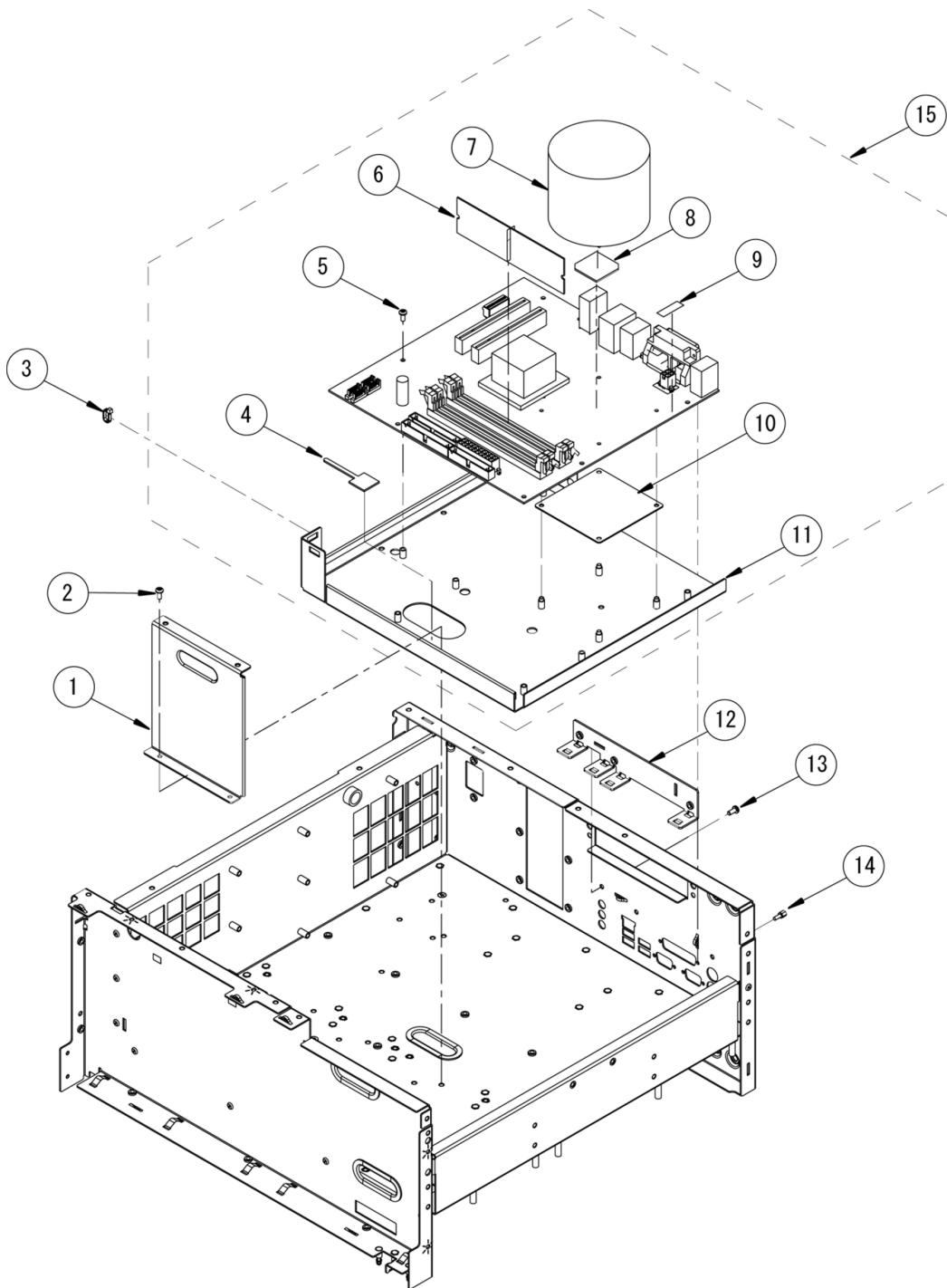
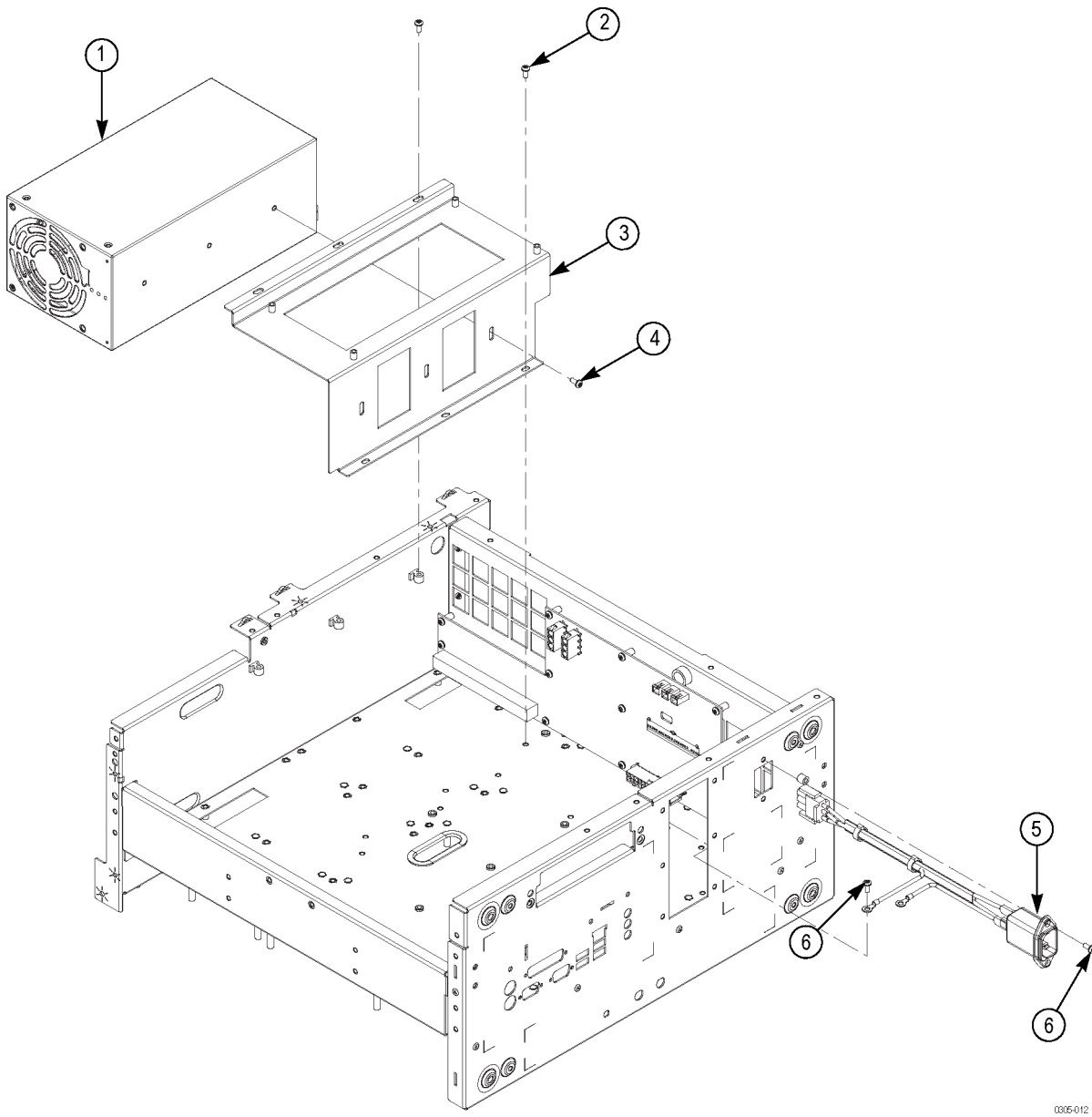

Figure 5-10: AWG7000B Series processor module

Table 5-11: Replaceable parts list – AWG7000C series power supply assembly

Fig. & index number	Tektronix part number	Serial no. effective	Serial no. discont'd	Qty	Name & description
5-11-					POWER SUPPLY ASSEMBLY
-1	119-6986-03			1	POWER SUPPLY; AC-DC;460W;+3.3V 40A,+5V 34A,+12V 25A,-12V 1A,+5VSB 2A;90-264VAC,47-63HZ;BERG 51624-XX001; 9.5X4.9X3.8IN,SAFETY CONTROLLED
-2	211-1050-00			6	SCREW,MACHINE; 6-32 X 0.312 L,PNH,STL CAD PLT,T15
-3	407-5145-01			1	BRACKET, POWER SUPPLY
-4	211-1050-00			3	SCREW,MACHINE; 6-32 X 0.312 L,PNH,STL CAD PLT,T15
-5	174-5269-00			1	CABLE ASSY; AC INLET TO CKT BD,14 IN L,AWG16 X 3, W/FN9222-10/06 FILTER/1-480700 CONN
-6	211-1050-00			4	SCREW,MACHINE; 6-32 X 0.312 L,PNH,STL CAD PLT,T15



0805-012

Figure 5-11: AWG7000C Series power supply assembly

Table 5-12: Replaceable parts list – AWG7000B series power supply assembly

Fig. & index number	Tektronix part number	Serial no. effective	Serial no. discont'd	Qty	Name & description
5-12-					POWER SUPPLY ASSEMBLY
-1	119-6986-03			1	POWER SUPPLY; AC-DC;460W;+3.3V 40A,+5V 34A,+12V 25A, -12V 1A,+5VSB 2A;90-264VAC,47-63HZ;BERG 51624-XX001; 9.5X4.9X3.8IN,SAFETY CONTROLLED
-2	211-1050-00			6	SCREW,MACHINE; 6-32 X 0.312 L,PNH,STL CAD PLT,T15
-3	407-5145-01			1	BRACKET, POWER SUPPLY
-4	211-1050-00			3	SCREW,MACHINE; 6-32 X 0.312 L,PNH,STL CAD PLT,T15
-5	174-5269-00			1	CABLE ASSY; AC INLET TO CKT BD,14 IN L,AWG16 X 3, W/FN9222-10/06 FILTER/1-480700 CONN
-6	211-1050-00			4	SCREW,MACHINE; 6-32 X 0.312 L,PNH,STL CAD PLT,T15
-7	407-5369-00			1	BRACKET, SUPPORT; ANTI-SHOCK, DUMMY POWER SUPPLY, .063 ALUMINUM WITH 2 SORTS OF ABSORBERS ATTACHED (AWG7000B SERIES ONLY)
-8	211-1050-00			4	SCREW,MACHINE; 6-32 X 0.312 L,PNH,STL CAD PLT,T15 (AWG7000B SERIES ONLY)

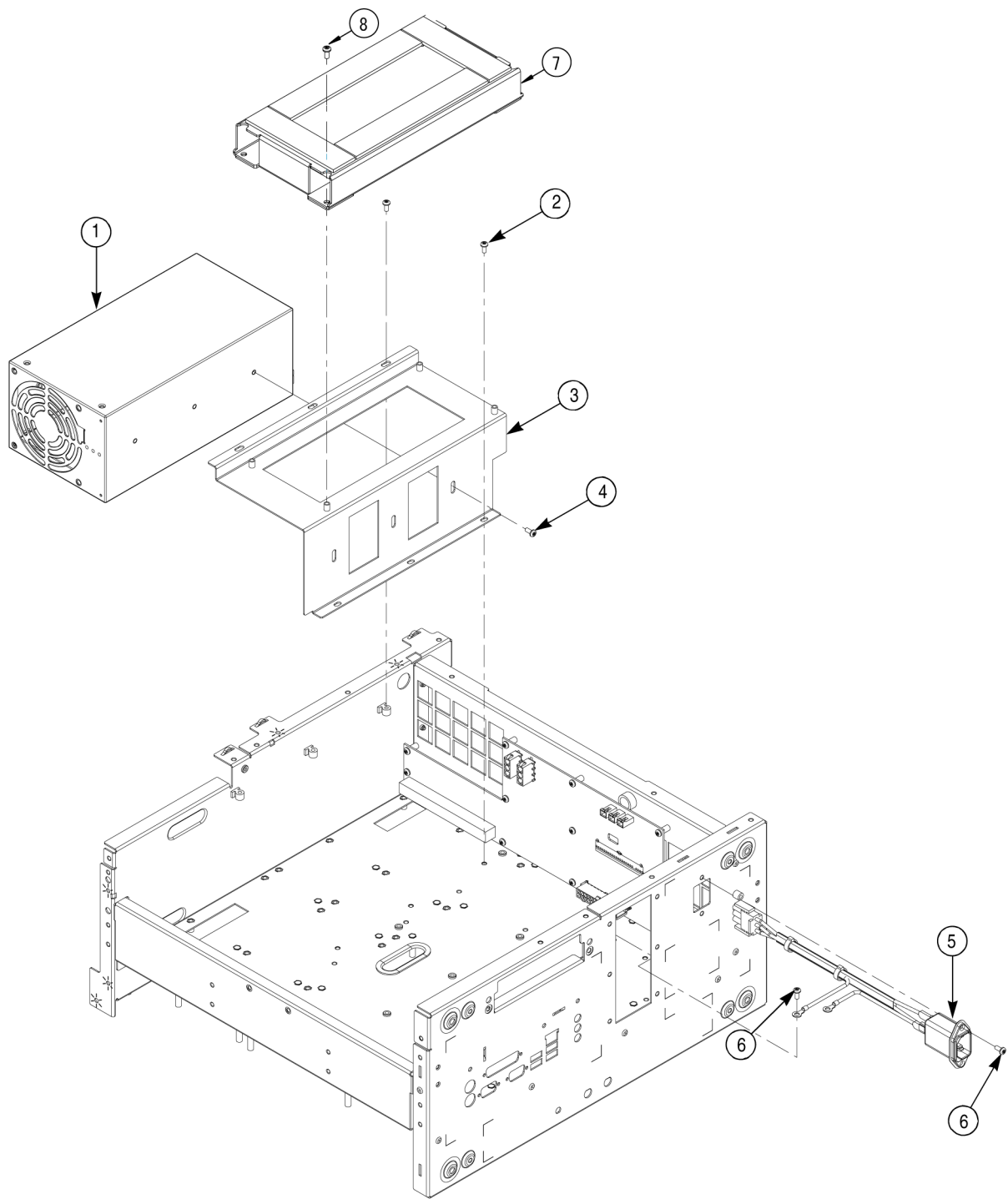
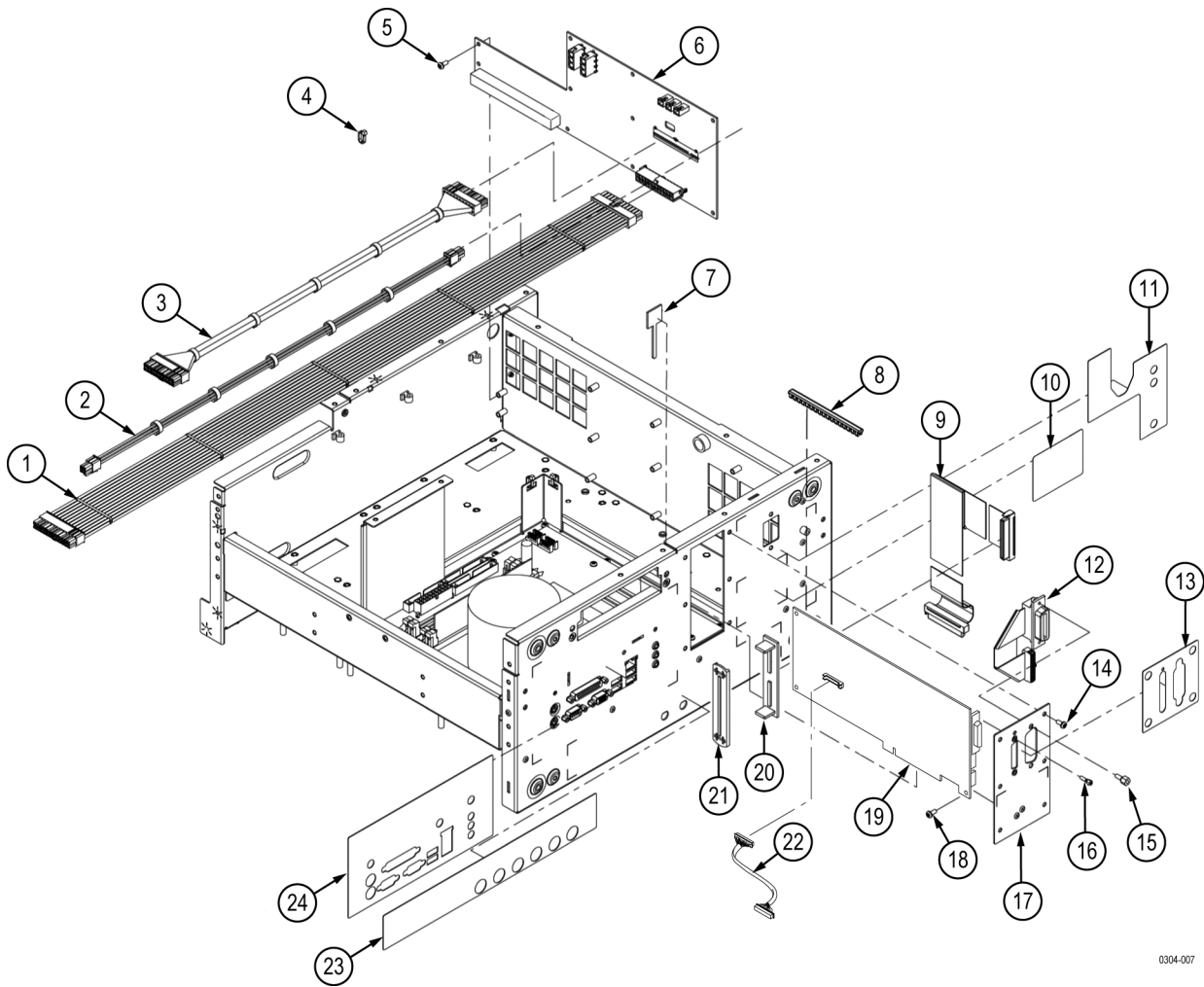

Figure 5-12: AWG7000B Series power supply assembly

Table 5-13: Replaceable parts list – AWG7000C Series PCI/power interface module

Fig. & index number	Tektronix part number	Serial no. effective	Serial no. discont'd	Qty	Name & description
5-13-					PCI/POWER INTERFACE MODULE
-1	174-5246-00			1	CABLE ASSY ELEC: 2 X 12P,31IN L,AWG16 X 24,39-01-2245, 39-01-2245,MOLEX
-2	174-4798-00			1	CABLE ASSEMBLY; 4 PIN P4 POWER,SAFETY CONTROLLED
-3	174-4797-00			1	CABLE ASSEMBLY; 20 PIN ATX POWER,SAFETY CONTROLLED
-4	346-0128-00			2	STRAP,TIEDOWN;8.0 L X 0.1 W,NYLON
-5	211-1050-00			10	SCREW,MACHINE; 6-32 X 0.312 L,PNH,STL CAD PLT,T15
-6	679-6064-03			1	CIRCUIT BOARD ASSY; POWER DC-DC, 389-3775-00 (INCLUDES 4)
-7	343-1701-00			1	CLAMP,CABLE; WITH ADHESIVE BACK
-8	348-1952-00			1	GROMMET, PLASTIC; U SHAPE, 2.210 L, NATURAL, RICHCO#MSG-1-01
-9	174-5245-00			1	CABLE ASSY ELEC: FLAT CABLE,TWISTED PAIR,68P,0.05 PITCH, 20IN L,SDA-71660-3568,MOLEX
-10	335-0347-00				MARKER,IDENT; REAR PANEL,BLANK,2.100 X 2.700,SAFETY CONTROLLED
-11	335-1663-00			1	MARKER,IDENT; LABEL,COSMETIC,REAR,LEXAN, SAFETY CONTROLLED
-12	174-5307-00			1	CABLE ASSY ELEC: GPIB,5INL,BOARD TO REAR PANEL,24P GPIB CONN TO 24P HEADER CONN,W/O JACK SCREW, SAFETY CONTROLLED
-13	335-1668-00			1	MARKER,IDENT; LABEL, I/O FOR PCI PCB (ATTACHES TO PCI PCB BRACKET), SAFETY CONTROLLED
-14	211-1050-00			6	SCREW,MACHINE; 6-32 X 0.312 L,PNH,STL CAD PLT,T15
-15	213-1061-00			2	JACKSCREW; 6-32 X 0.320 EXT THD,M3.5 X 0.6-6 INT THD X 0.215L, GPIB, BLACK OXIDE, BULK PACK
-16	211-1206-01			2	SCREW,JACK; 2-56 ID X 4-40 OD,0.188 HEX,SS
-17	386-7462-01			1	BRACKET, REAR: MIO
-18	211-1050-00			1	SCREW,MACHINE; 6-32 X 0.312 L,PNH,STL CAD PLT,T15
-19	870-0474-00			1	CIRCUIT BOARD ASSEMBLY; MIO WITH PCIE, MULTI -I/O,FUNCTIONAL BOARD TESTED INCLUDES 20 AND 21
-20	343-1627-00			1	CABLE,CLAMP; 0.5H X 2.98L,0.625 W,NYLON 6-6, ADHESIVE,COVER 343-1636-00
-21	343-1636-00			1	CLAMP, COVER; FLT CABLE ROUTING CLAMP, 343-1627-00 BASE
-22	174-5629-00			1	CABLE, LVDS VIDEO WITH 2X20 HIROSE CONNECTORS
-23	335-2289-00			1	MARKER,IDENT; LABEL,COSMETIC,REAR,AWG,LEXAN, SAFETY CONTROLLED
-24	335-2290-00			1	MARKER,IDENT; LABEL,REAR I/O,MAIN,LEXAN, SAFETY CONTROLLED



0304-007

Figure 5-13: AWG7000C Series PCI/power interface module

Table 5-14: Replaceable parts list – AWG7000B Series PCI/power interface module

Fig. & index number	Tektronix part number	Serial no. effective	Serial no. discont'd	Qty	Name & description
5-14-					PCI/POWER INTERFACE MODULE
-1	174-5246-00			1	CABLE ASSY ELEC: 2 X 12P,31IN L,AWG16 X 24,39-01-2245, 39-01-2245, MOLEX
-2	174-4798-00			1	CABLE ASSEMBLY; 4 PIN P4 POWER,SAFETY CONTROLLED
-3	174-4797-00			1	CABLE ASSEMBLY; 20 PIN ATX POWER,SAFETY CONTROLLED
-4	174-5255-00	B010000	B019999	1	CABLE ASSY ELEC: 2P,0.1,11.8IN L,AWG 22,UL1430,22-01-3027, 08-50-0114 CONTACT, MOLEX
-5	211-1050-00			10	SCREW,MACHINE; 6-32 X 0.312 L,PNH,STL CAD PLT,T15
-6	679-6064-03			1	CIRCUIT BOARD ASSY; POWER DC-DC
-7	343-1701-00			1	CLAMP,CABLE; WITH ADHESIVE BACK
-8	335-1663-00			1	MARKER, IDENT; LABEL, COSMETIC, REAR, LEXAN
-9	335-0347-00				MARKER,IDENT; REAR PANEL,BLANK,2.100 X 2.700,SAFETY CONTROLLED
-10	174-5245-00			1	CABLE ASSY ELEC: FLAT CABLE,TWISTED PAIR,68P,0.05 PITCH, 20IN L, SDA-71660-3568,MOLEX
-11	174-5307-00			1	CABLE ASSY ELEC: GPIB, 5 IN L, BOARD TO REAR PANEL,W/O JACK SCREW, SAFETY CONTROLLED
-12	335-1668-00			1	MARKER,IDENT; LABEL, I/O FOR PCI PCB (ATTACHES TO PCI PCB BRACKET), SAFETY CONTROLLED
-13	211-1050-00			6	SCREW,MACHINE; 6-32 X 0.312 L,PNH,STL CAD PLT,T15
-14	213-1061-00			2	JACKSCREW; 6-32 X 0.320 EXT THD,M3.5 X 0.6-6 INT THD X 0.215L, GPIB, BLACK OXIDE, BULK PACK
-15	211-1206-01			2	SCREW,JACK; 2-56 ID X 4-40 OD,0.188 HEX,SS
-16	386-7462-00			1	BRACKET, REAR: MIO
-17	211-1050-00			1	SCREW,MACHINE; 6-32 X 0.312 L,PNH,STL CAD PLT,T15
-18	671-6049-01	B010000	B019999	1	CIRCUIT BOARD ASSY; MIO MULTI-I/O, FR-4
	671-7024-00	B020000		1	CIRCUIT BOARD ASSY; MIO MULTI-I/O BOARD FOR ADD2 CARD, FR-4,W/CABLE CLAMP BACKSIDE
-19	343-1627-00			1	CABLE,CLAMP; 0.5H X 2.98L,0.625 W,NYLON 6-6,ADHESIVE
-20	211-1050-00	B020000		2	SCREW,MACHINE; 6-32 X 0.312 L,PNH,STL CAD PLT,T15
-21	386-7518-00	B020000		1	SUPPORT, PCB; ADD2
-22	174-5609-00	B020000		1	CA ASSY,SP; 40/20 TW PR,28 AWG,12 IN L W/SHEATH ,UL20276 EQ, ADD2 TO MIO, SAFETY CONTROLLED
-23	119-7549-00	B020000		1	ADD2 DISPLAY ADAPTER CARD WITH LVDS SUPPORT
-24	348-1952-00	B020000		2	GROMMET, PLASTIC; U SHAPE, 2.210 L, NATURAL, RICHCO#MSG-1-01
-25	129-1658-00	B020000		1	SPACER POST: 6-32M/F,1.125L, 1/4HEX,THREADS
-26	343-1701-00	B020000		1	CLAMP,CABLE; WITH ADHESIVE BACK
-27	174-5610-00	B020000		1	CA ASSY,SP; DISCRETE; 5,24 AWG,12 IN L,MIO TO ADD2, SAFETY CONTROLLED
-28	335-1664-00			1	MARKER,IDENT; LABEL,COSMETIC,REAR,LEXAN
-29	335-1978-00			1	MARKER,IDENT; LABEL,REAR I/O,MAIN,LEXAN, SAFETY CONTROLLED
-30	348-1952-00			1	GROMMET, PLASTIC; U SHAPE, 2.210 L, NATURAL, RICHCO#MSG-1-01

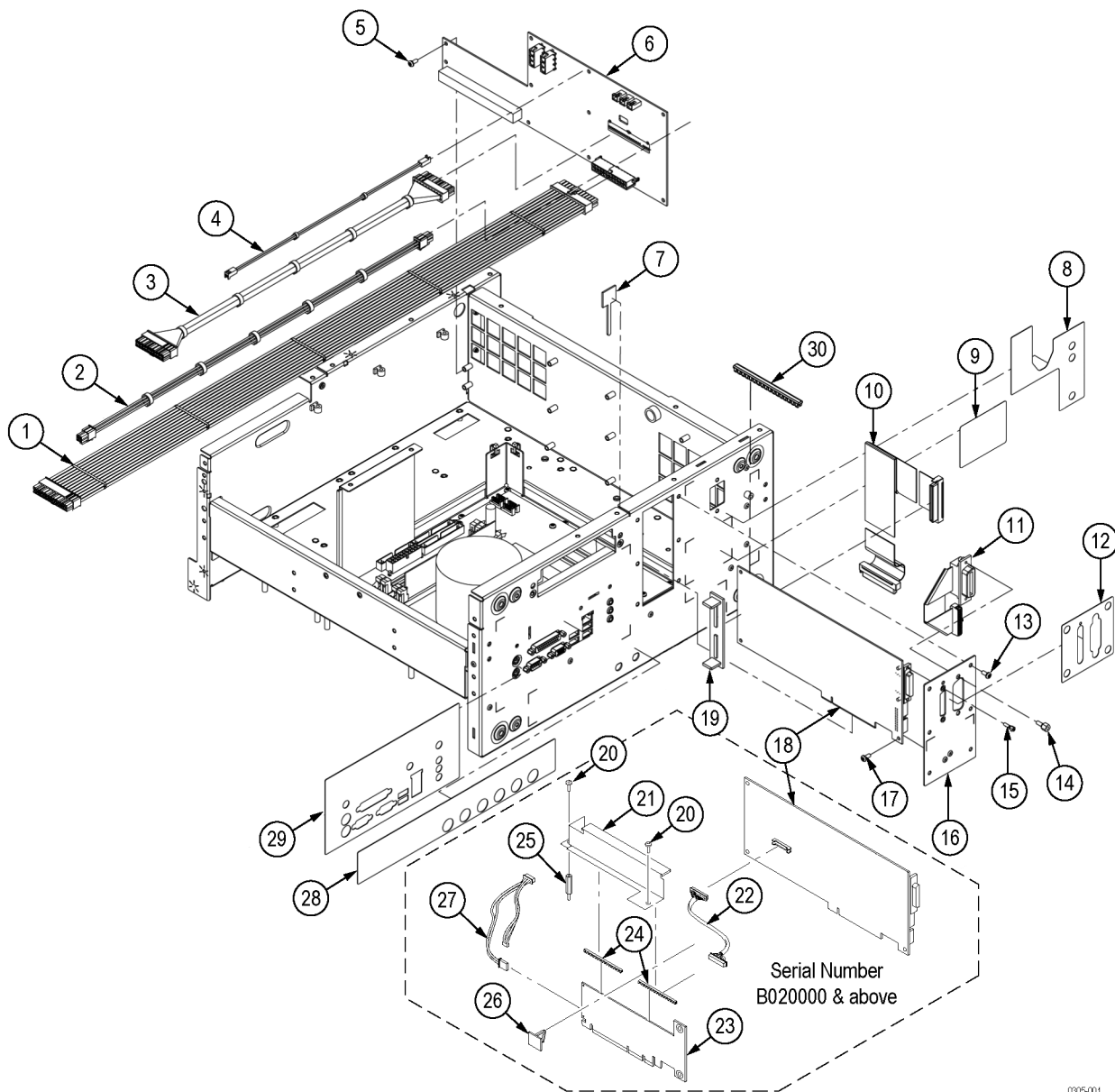

0305-001

Figure 5-14: AWG7000B Series PCI/power interface module

Table 5-15: Replaceable parts list – fan tray assembly

Fig. & index number	Tektronix part number	Serial no. effective	Serial no. discont'd	Qty	Name & description
5-15-					FAN TRAY ASSEMBLY
-1	211-1050-00			4	SCREW,MACHINE; 6-32 X 0.312 L,PNH,STL CAD PLT,T15
-2	211-1213-01			12	SCREW, METRIC 5 X 10MM, FLATHEAD, STL, ZINC, POSI
-3	407-5170-02			1	BRACKET,FAN TRAY
-4	343-0549-00			2	STRAP,TIEDOWN; 0.098 W X 4.0 L, ZYTEL
-5	119-7182-00			3	FAN,TUBEAXIAL; 12VDC,0.40A,4.80W,2500RPM,100.6CFM, 120MM, LEADS W/CONN; SAFETY CONTROLLED

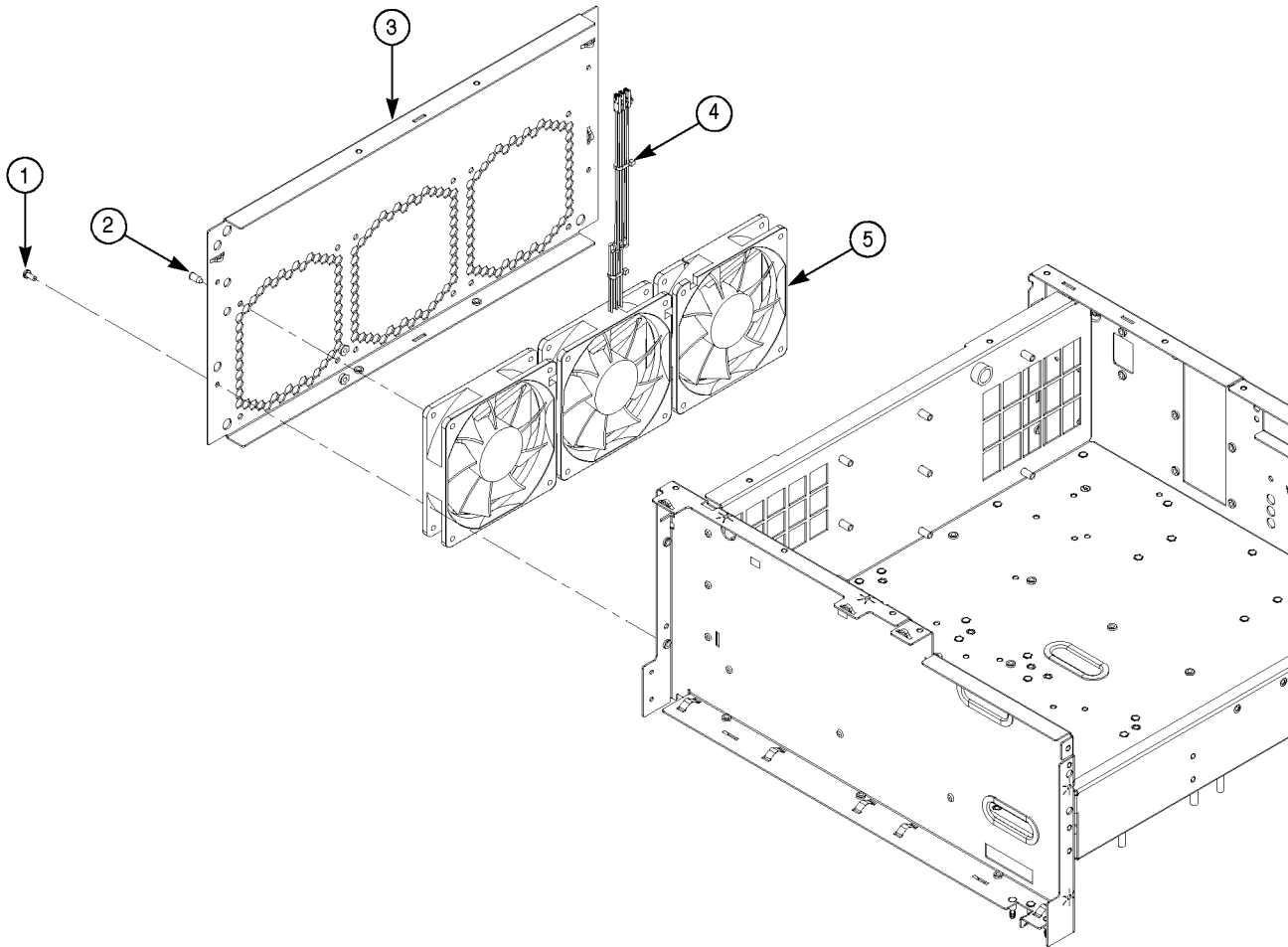

Figure 5-15: Fan tray assembly

Table 5-16: Replaceable parts list – USB module

Fig. & index number	Tektronix part number	Serial no. effective	Serial no. discontinued	Qty	Name & description
5-16-					USB MODULE
-1	211-1050-00			2	SCREW,MACHINE; 6-32 X 0.312 L,PNH,STL CAD PLT,T15
-2	679-6350-02			1	CIRCUIT BOARD ASSY; FCON, FRONT PANEL CONNECTOR
-3	174-5233-00			1	CA ASSY,INTCON; CMPST,USB2.0,24/28 AWG,24 IN L,10 POS,1 X 10 AND 2 X 5,USB2.0 CABLE X 2,0.1 CTR
-4	174-5474-00			1	CABLE ASSY ELEC: 1 X 8P,FLAT,0.1,16.8IN L,AWG 26,103958-7 AMP

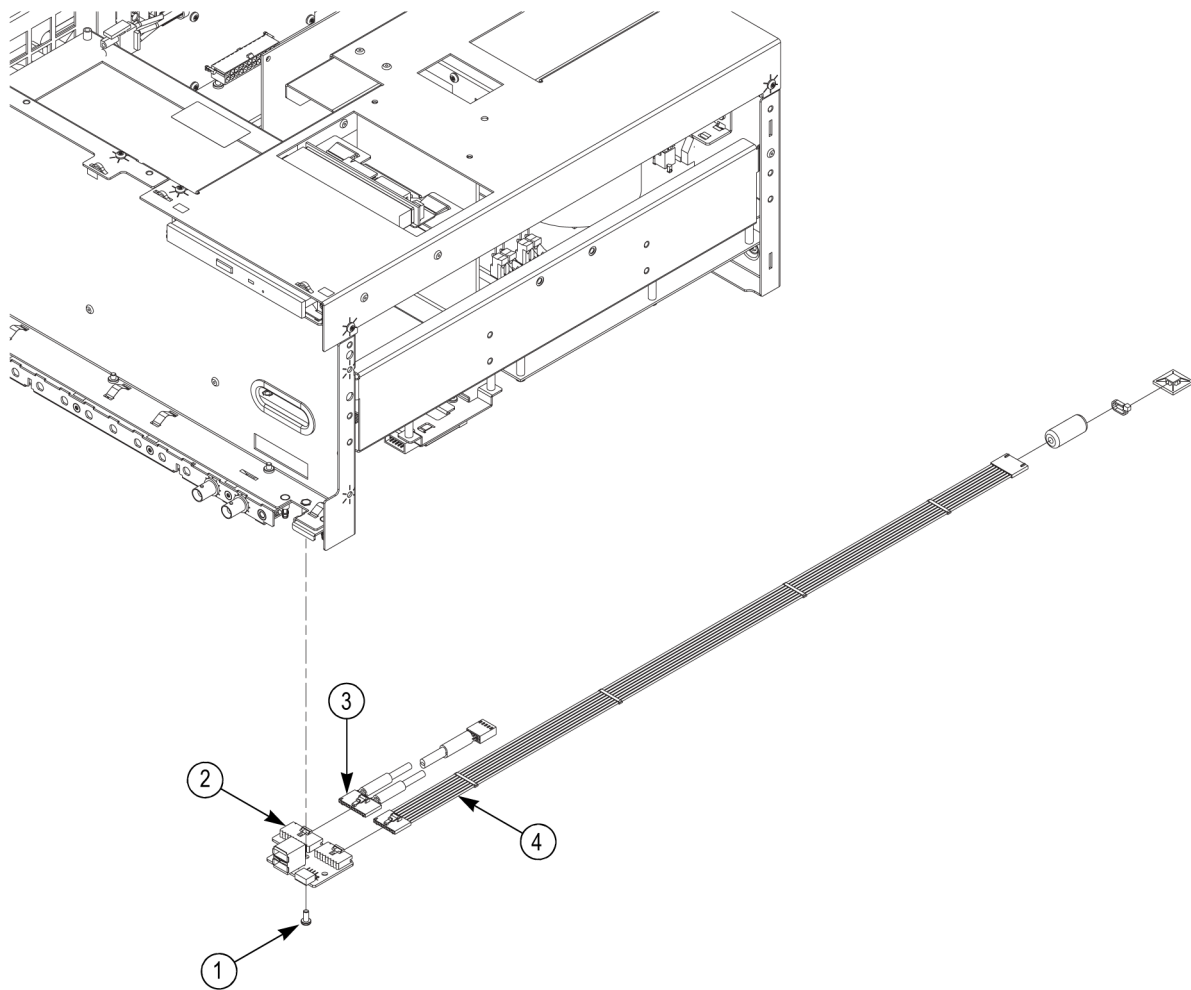

Figure 5-16: USB module

Table 5-17: Replaceable Parts List – AWG12G/CLK12G/OUT10G modules

Fig. & index number	Tektronix part number	Model	Serial no. effective	Serial no. discont'd	Qty	Name & description
5-17-						AWG12G/CLK12G/OUT10G MODULES
-1	211-1050-00				11	SCREW,MACHINE; 6-32 X 0.312 L,PNH,STL CAD PLT,T15
-2	210-0586-00	AWG7xx1B			8	NUT,PL,ASSY WA; 4-40 X 0.25,STL CD PL
	210-0586-00	AWG7xx2C AWG7xx2B			16	NUT,PL,ASSY WA; 4-40 X 0.25,STL CD PL
-3	214-5120-00	AWG7xx1B			2	HEAT SINK,SEMIC; IC,FLAT PKG,BLOCK,OUT10G, ALPHA T40-6B MACHINED, 40 X 40 X 6MM,USED W/407520600 & 348188300
	214-5120-00	AWG7xx2C AWG7xx2B			4	HEAT SINK,SEMIC; IC,FLAT PKG,BLOCK,OUT10G,ALPHA T40-6B MACHINED, 40 X 40 X 6MM,USED W/407520600 & 348188300
-4	407-5206-00	AWG7xx1B			1	BRACKET HEATSK; OUT10G,0.05,AL
	407-5206-00	AWG7xx2B			2	BRACKET HEATSK; OUT10G,0.05,AL
	407-5510-00	AWG7xx2C			2	BRACKET, HEATSINK, OUT10G
-5	342-1157-00	AWG7xx1B			1	INSULATOR; THERMAL CONDUCTIVE SHEET,0.070 G580, 1.850 X 3.250
	342-1157-00	AWG7xx2C AWG7xx2B			2	INSULATOR; THERMAL CONDUCTIVE SHEET,0.070 G580, 1.850 X 3.250
-6	211-1050-00	AWG7xx1B			9	SCREW,MACHINE; 6-32 X 0.312 L,PNH,STL CAD PLT,T15
	211-1050-00	AWG7xx2C AWG7xx2B			18	SCREW,MACHINE; 6-32 X 0.312 L,PNH,STL CAD PLT,T15
	211-1050-00				12	SCREW,MACHINE; 6-32 X 0.312 L,PNH,STL CAD PLT,T15
-8	348-1887-00	AWG7xx1B			1	GASKET,ELEC;CONDUCTIVE URETHANE FORM 0.158X0.236X0.400, W/ADHESIVE,LAIRD #4704
	348-1887-00	AWG7xx2C AWG7xx2B			2	GASKET,ELEC;CONDUCTIVE URETHANE FORM 0.158X0.236X0.400, W/ADHESIVE,LAIRD #4704
-9	348-1886-00	AWG7xx1B			1	GASKET,ELEC;CONDUCTIVE URETHANE FORM 0.158X0.236X1.000, W/ADHESIVE,LAIRD #4704
	348-1886-00	AWG7xx2C AWG7xx2B			2	GASKET,ELEC;CONDUCTIVE URETHANE FORM 0.158X0.236X1.000, W/ADHESIVE,LAIRD #4704
-10	348-1888-00				1	ABSORBER,RF: 3.050X0.800X0.079,W/ADHESIVE,TDK IRB02A2
-11	348-1885-00	AWG7xx1			2	GASKET,ELEC;CONDUCTIVE URETHANE FORM 0.080X1.345X3.050, W/ADHESIVE, LAIRD #4315
	348-1885-00	AWG7xx2C AWG7xx2B			4	GASKET,ELEC;CONDUCTIVE URETHANE FORM 0.080X1.345X3.050, W/ADHESIVE, LAIRD #4315
-12	337-4397-00	AWG7xx1B			1	BRACKET; SHIELD,COVER,OUT10G BD
	337-4397-00	AWG7xx2C AWG7xx2B			2	BRACKET; SHIELD,COVER,OUT10G BD
-13	211-1050-00				10	SCREW,MACHINE; 6-32 X 0.312 L,PNH,STL CAD PLT,T15
-14	211-0691-00				4	SCR,ASSEM WSHR; 6-32 X 0.625,PNH,STL,CDPL,T-15 TORX DR, MACHINE

Table 5-17: Replaceable Parts List – AWG12G/CLK12G/OUT10G modules (cont.)

Fig. & index number	Tektronix part number	Model	Serial no. effective	Serial no. discont'd	Qty	Name & description
-15	671-6476-00	AWG7xx2C			2	CIRCUIT BOARD; OUTPUT 10G1, STD,NELCO N-4000-13SI,6L,AU,IMPEDANCE CONTROLLED, SAFETY CONTROLLED, W/O OKAYA BIAS-TEE
	671-6479-00	AWG7xx2C Option 06			2	CIRCUIT BOARD ASSY; OUTPUT 10G1,OPTION,NELCO N-4000-13SI,6L,AU,IMPEDANCE CONTROLLED, SAFETY CONTROLLED,W/O OKAYA BIAS-TEE
	671-9962-00	AWG7xx1B			1	CIRCUIT BOARD ASSY; OUTPUT 10GS, STD, 389-3776-00
	671-9952-00	AWG7xx2B			2	CIRCUIT BOARD ASSY; OUTPUT 10GS, STD, 389-3776-00
	671-9953-00	AWG7121B Option 02			1	CIRCUIT BOARD ASSY; OUTPUT 10GS, OPTION, NO OKAYA MADE BIAS-T POPULATED
	671-9953-00	AWG7122B Option 06			2	CIRCUIT BOARD ASSY; OUTPUT 10GS, OPTION, NO OKAYA MADE BIAS-T POPULATED
-16	348-1890-00	AWG7xx1B			1	ABSORBER: RF,2.950 SQX0.079 THICK,W/ADHESIVE, TDK IRB02A2
	348-1890-00	AWG7xx2B AWG7xx2C			2	ABSORBER: RF,2.950 SQX0.079 THICK,W/ADHESIVE, TDK IRB02A2
-17	348-1889-00				1	ABSORBER,RF: 11.810X0.925X0.079 THICK, W/ADHESIVE, TDK IRB02A2

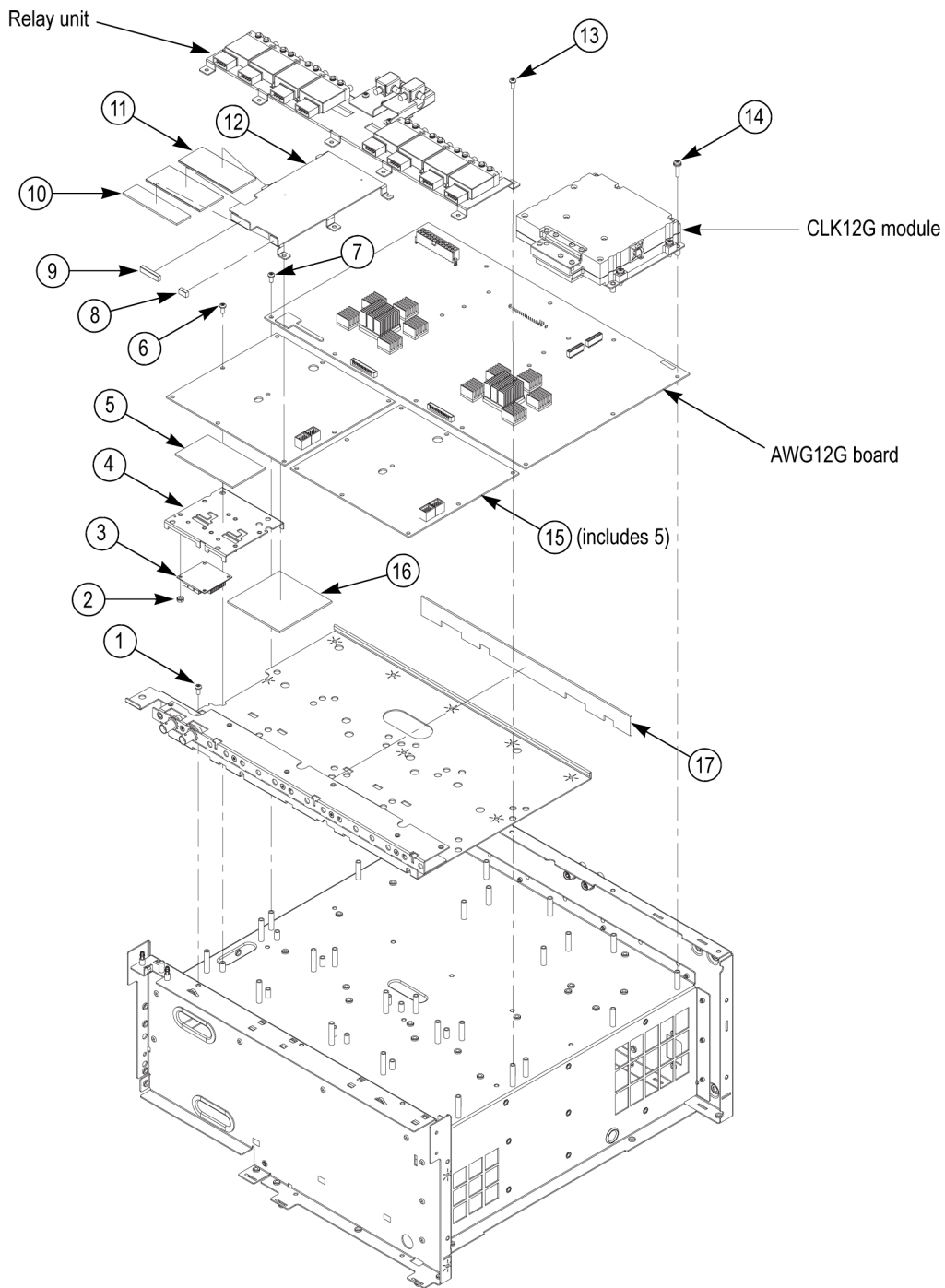

Figure 5-17: AWG12G/CLK12G/OUT10G modules

Table 5-18: Replaceable parts list – CLK12G module

Fig. & index number	Tektronix part number	Serial no. effective	Serial no. discont'd	Qty	Name & description
5-18-					CLK12G MODULE
-1	174-5328-00			1	CABLE ASSY ELEC: RF,COAX,11.8IN L,50 OHM,SMP-R RTANG TO SMP-R RTANG,FLEX COAX CABLE,VSWR 1.35 IL 1.3DB AT 12GHZ
-2	011-0184-00			1	TERMINATION: COAX,50 OHM,+20DBM,SMP,FEMALE,DC-18GHZ, VSWR 1.2 AT 15GHZ 1.25 AT 18GHZ,GOLD W NI UNDERPLATED,P918-1CC, TENSOLITE (AWG7000B SERIES ONLY)
-3	211-0372-00			2	SCREW, MACHINE; 4-40 X 0.312, PNH, STEEL, ZINC FINISH, TORX T10
-4	211-1235-00			10	SCREW,MACHINE; W/HEAVY PATCH THREADLOCKING MATERIAL; 4-40 X 1.0,PNH,STL CD PLT,T10
-5	348-1931-00			1	GASKET;SHEET FOR SMP CONNECTOR
-6	386-7508-00			1	PLATE; HOLDDOWN GASKET SHEET SMP
-7	211-0324-00			2	SCR,ASSEM WSHR; 4-40 X 0.188,PNH,SST,PASS,T-10 TORX DR,MACHINE
-8	211-1237-00			1	SCREW,MACHINE; W/HEAVY PATCH THREADLOCKING MATERIAL; 4-40 X 0.75,PNH, STL CD PLT,T10
-9	352-0482-00			2	HOLDER,CABLE TIE; 0.75 SQ,STICKY BACK,PLASTIC,SAFETY CONTROLLED
-10	343-0549-00			2	HOLDER,CABLE TIE; 0.75 SQ,STICKY BACK,PLASTIC,SAFETY CONTROLLED
-11	337-4441-00			1	SHIELD,ELEC;CASE TOP CLK12G
-12	342-1174-00			1	INSULATOR; THERMAL CONDUCTIVE SHEET,0.04 G974,0.83 X 0.5,CHOMERICS
-13	342-1155-00			1	INSULATOR; THERMAL CONDUCTIVE SHEET,0.04 G974,0.787 X 0.787, CHOMERICS
-14	211-0250-00			2	SCREW,MACHINE; 2-56 X 0.937,FLH,STL CD PL,POZ
-15	119-7434-00			1	OSCILLATOR,YIG: 4.7GHZ TO 12.8GHZ,+12V170MA,-5V30MA,HEATER+12V70MA MAX300MA,20MHZ/MA,+9DBM,FS2820,TELEDYNE
-16	174-5289-00			1	CABLE ASSY ELEC: RF,COAX,1.7IN L,50 OHM,SMP-R RTANG,SMA-P RTANG, FLEX COAX CABLE
-17	679-6422-00			1	CIRCUIT BD ASSY,OUTSOURCED;389-4047-XX WIRED,CLK12G
-18	210-0001-00			2	WASHER,LOCK; #2 INTL,0.013 THK,STL CD PL
-19	210-0405-00			2	NUT,PLAIN,HEX; 2-56 X 0.188,BRS CD PL
-20	342-1156-01			1	INSULATOR; THERMAL CONDUCTIVE SHEET,0.04 G974,2.85 X 2.10, CHOMERICS
-21	211-0691-00			4	SCR,ASSEM WSHR; 6-32 X 0.625,PNH,STL,CDPL,T-15 TORX DR,MACHINE
-22	337-4442-00			1	SHIELD,ELEC;CASE BOTTOM CLK12G
-23	214-5156-00			2	PIN; LOCATING CLK12G RF SHIELD CASE UNIT
-24	407-5319-00			1	BRACKET;SHIELD CASE FOR CLK12G

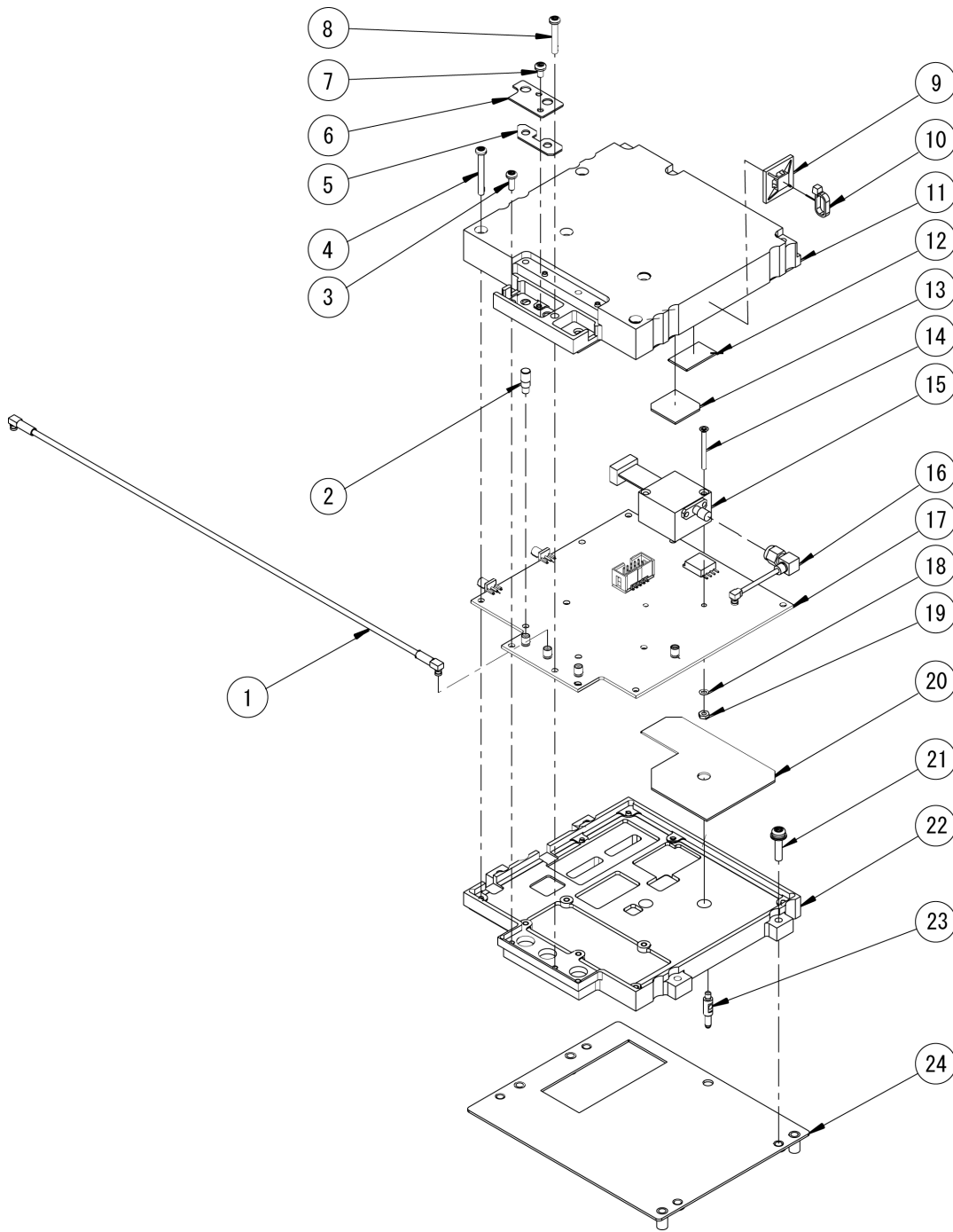

Figure 5-18: CLK12G module

Table 5-19: Replaceable parts list – AWG12G module

Fig. & index number	Tektronix part number	Model	Serial no. effective	Serial no. discont'd	Qty	Name & description
5-19-						AWG12G MODULE
-1	352-1114-00				1	HOLDER; CABLE RETENTION SMA,PORON URETHANE, FOR MATCHED PAIR RF CABLE,AWG
-2	174-5341-00	AWG7xx1B			2	CABLE ASSY ELEC: RF,COAX,8IN L,50 OHM,SMP-R RTA, SMP-R RTA, W/LABEL, MATCHED DELAY FLEX COAX CABLE
	174-5341-00	AWG7xx2C AWG7xx2B			4	CABLE ASSY ELEC: RF,COAX,8IN L,50 OHM,SMP-R RTA, SMP-R RTA, W/LABEL, MATCHED DELAY FLEX COAX CABLE
-3	174-5340-00	AWG7121B Option 02			1	CABLE ASSY ELEC: RF,COAX,8IN L,50 OHM,SMP-R RTA, SMA-P STR, W/LABEL, MATCHED DELAY FLEX COAX CABLE
	174-5340-00	AWG7122C Option 06 AWG7122B Option 06			2	CABLE ASSY ELEC: RF,COAX,8IN L,50 OHM,SMP-R RTA, SMA-P STR, W/LABEL, MATCHED DELAY FLEX COAX CABLE
-4	343-1701-00				1	CLAMP,CABLE; WITH ADHESIVE BACK
-5	174-5342-00	AWG7xx1B			1	CABLE ASSY ELEC: RF,COAX,8IN L,50 OHM,SMP-R RTA, SMP-R RTA, W/LABEL, MATCHED DELAY FLEX COAX CABLE
	174-5342-00	AWG7xx2C AWG7xx2B			2	CABLE ASSY ELEC: RF,COAX,8IN L,50 OHM,SMP-R RTA, SMP-R RTA, W/LABEL, MATCHED DELAY FLEX COAX CABLE
-6	174-5249-00	AWG7xx1B			1	CABLE ASSY ELEC: 1 X 16P,6.5IN L,AWG24 X 16, PHR-16,PHR-16,JST
	174-5249-00	AWG7xx2C AWG7xx2B			2	CABLE ASSY ELEC: 1 X 16P,6.5IN L,AWG24 X 16, PHR-16,PHR-16,JST
-7	352-0482-00				1	HOLDER,CABLE TIE; 0.75 SQ,STICKY BACK,PLASTIC, SAFETY CONTROLLED
-8	343-0549-00				1	STRAP,TIEDOWN; 0.098 W X 4.0 L, ZYTEL
-9	664-6421-02	AWG7xx2B AWG7xx2C			1	CIRCUIT BOARD ASSY; AWG12G,2CHANNEL GENERATOR, 389-4020-XX WIRED

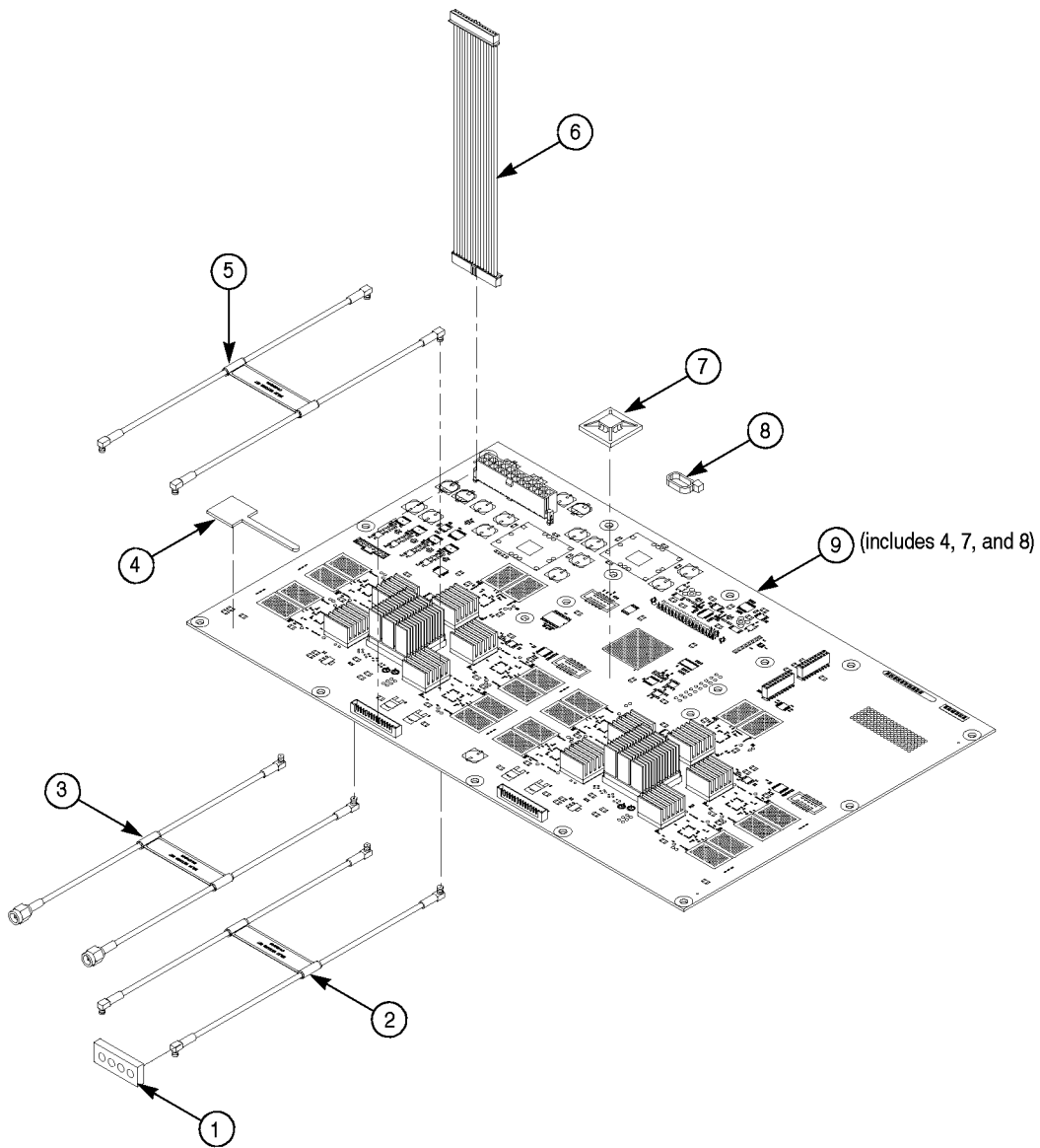

Figure 5-19: AWG12G module

Table 5-20: Replaceable parts list – SMA bracket

Fig. & index number	Tektronix part number	Model	Serial no. effective	Serial no. discount'd	Qty	Name & description
5-20-						SMA BRACKET
-1	407-5144-00				1	BRACKET, SMA: FRONT I/O
-2	211-0734-00				5	SCREW,MACHINE; 6-32 X 0.250,FLH100,STL,CDPL,T-10 TORX DR
-3	407-5222-00				1	BRACKET, SMA: FRONT I/O BNC AREA
-4	131-8054-00				2	CONN,RF,JACK; BNC,PNL,50 OHM,FEMALE,STR, PELTOLA/PNL MNT,SILVER ALLOY, 0.576 MLG X 0.366 TERMN,0.375-32 THD,D-FLAT
-5	174-5244-00				2	CABLE ASSY ELEC: RF,COAX,22.8IN L,50 OHM, PELTOLA,PELTOLA,FLEX COAX CABLE
-6	174-5344-00	AWG7xx1B			1	CABLE ASSY ELEC: RF,COAX,9.5IN L,50 OHM,SMA-R STR PANEL,SMP-R RTA, W/LABEL,MATCHED DELAY FLEX COAX CABLE
	174-5344-00	AWG7xx2C AWG7xx2B			2	CABLE ASSY ELEC: RF,COAX,9.5IN L,50 OHM,SMA-R STR PANEL,SMP-R RTA, W/LABEL,MATCHED DELAY FLEX COAX CABLE
-7	174-5343-00	AWG7xx1B			2	CABLE ASSY ELEC: RF,COAX,7IN L,50 OHM,SMP-R RTA, SMA-R STR, PANEL MOUNT, W/LABEL,MATCHED DELAY FLEX COAX CABLE
	174-5343-00	AWG7xx2C AWG7xx2B			4	CABLE ASSY ELEC: RF,COAX,7IN L,50 OHM,SMP-R RTA, SMA-R STR, PANEL MOUNT, W/LABEL,MATCHED DELAY FLEX COAX CABLE
-8	174-5337-00	AWG7121B Option 02			1	CABLE ASSY ELEC: RF,COAX,13.8IN L,50 OHM,SMA-P STR, SMA-R STR, PANEL MOUNT,W/LABEL,MATCHED DELAY FLEX COAX CABLE
	174-5337-00	AWG7122C Option 06 AWG7122B Option 06			3	CABLE ASSY ELEC: RF,COAX,13.8IN L,50 OHM,SMA-P STR, SMA-R STR, PANEL MOUNT,W/LABEL,MATCHED DELAY FLEX COAX CABLE

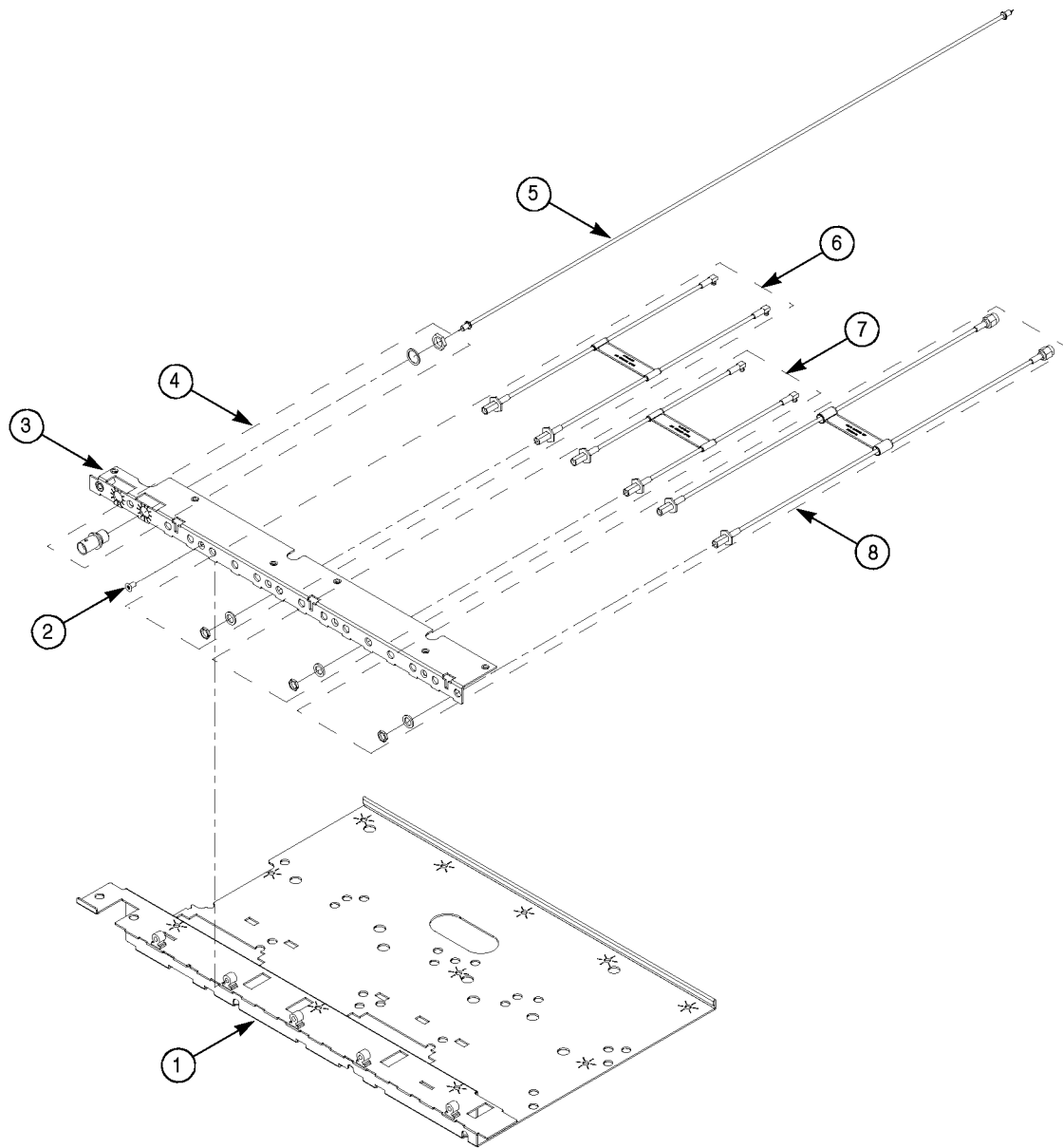

Figure 5-20: SMA bracket

Table 5-21: Replaceable parts list – relay unit

Fig. & index number	Tektronix part number	Model	Serial no. effective	Serial no. discont'd	Qty	Name & description
5-21-						RELAY UNIT (Option 02/06 only)
-1	174-5821-00	AWG7121B Option 02			1	CABLE ASSY ELEC: 10P, 0.1, 8IN L, 3P RIBBON X 2, FOR 148036800 RF RELAY
	174-5821-00	AWG7122C Option 06 AWG7122B Option 06			4	CABLE ASSY ELEC: 10P, 0.1, 8IN L, 3P RIBBON X 2, FOR 148036800 RF RELAY
-2	441-2461-00				1	CHASSIS, RELAY UNIT
-3	174-5338-00	AWG7122C Option 06 AWG7122B Option 06			1	CABLE ASSY ELEC: RF,COAX,4.4IN L,50 OHM,SMA-P STR, SMA-P STR,W/LABEL, MATCHED DELAY FLEX COAX CABLE
-4	211-1050-00	AWG7122C Option 06 AWG7122B Option 06			4	SCREW,MACHINE; 6-32 X 0.312 L,PNH,STL CAD PLT,T15
-5	343-1715-00	AWG7122C Option 06 AWG7122B Option 06			2	RETAINER;FOR RF POWER SPLITTER 015072000 1515-1 AEROFLEX/WEINSCHL INC
-6	015-0720-00	AWG7122B Option 06			2	POWER DIVIDER; 50 OHM,1 WATT,DC TO 18.0 GHZ,SMA FEMALE TO TWO SMA FEMALES,1515-1
-7	407-5198-00	AWG7122C Option 06 AWG7122B Option 06			1	BRACKET;FOR RF POWER SPLITTER 015072000 1515-1 AEROFLEX/WEINSCHL INC
-8	211-A273-01	AWG7121B Option 02			4	SCREW,MACHINE; M2.5X18 L,PNH,STL,NI PL,CROSS REC, W/FLAT & LOCK WASHER
	211-A273-01	AWG7122C Option 06 AWG7122B Option 06			16	SCREW,MACHINE; M2.5X18 L,PNH,STL,NI PL,CROSS REC, W/FLAT & LOCK WASHER
-9	174-5339-00	AWG7122B Option 06			2	CABLE ASSY ELEC: RF,COAX,6IN L,50 OHM,SMA-P STR, SMA-P STR,W/LABEL, MATCHED DELAY FLEX COAX CABLE
-10	174-5250-00	AWG7121B Option 02			2	CABLE ASSY ELEC: RF,COAX,10IN L,50 OHM,SMA-P STR, PELTOLA,W/MARK BAND, FLEX COAX CABLE
	174-5250-00	AWG7122C Option 06 AWG7122B Option 06			4	CABLE ASSY ELEC: RF,COAX,10IN L,50 OHM,SMA-P STR, PELTOLA,W/MARK BAND, FLEX COAX CABLE
-11	148-0341-00	AWG7121B Option 02			2	RELAY;ARMATURE;8H ANNEALING, 2 FORM C, 5 GHZ, 50 OHM, IL 0.5DB AT 5GHZ, 1W, SINGLE STABLE, COIL 12VDC, 720 OHM;ARJ20A12XJ01, 0.551L X 0.354W X 0.323H, 10 PIN SMD, T&R
	148-0341-00	AWG7122C Option 06 AWG7122B Option 06			8	RELAY;ARMATURE;8H ANNEALING, 2 FORM C, 5 GHZ, 50 OHM, IL 0.5DB AT 5GHZ, 1W, SINGLE STABLE, COIL 12VDC, 720 OHM;ARJ20A12XJ01, 0.551L X 0.354W X 0.323H, 10 PIN SMD, T&R

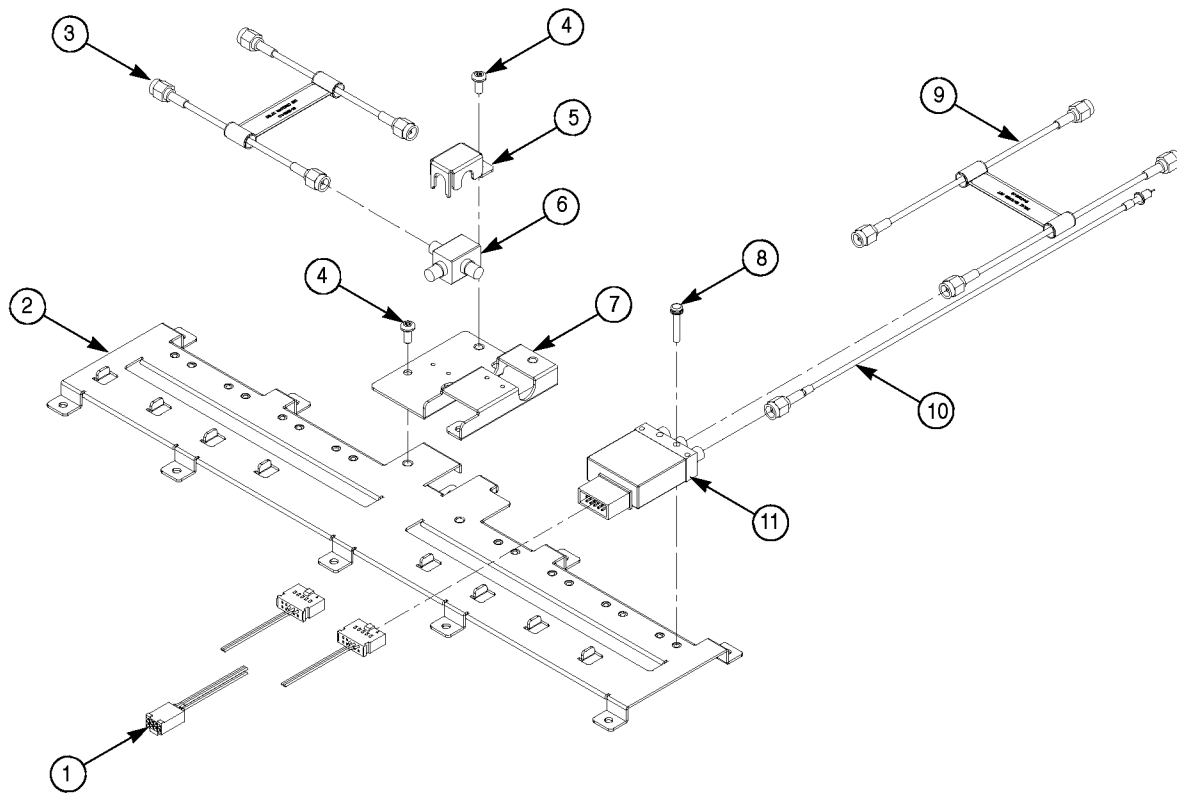
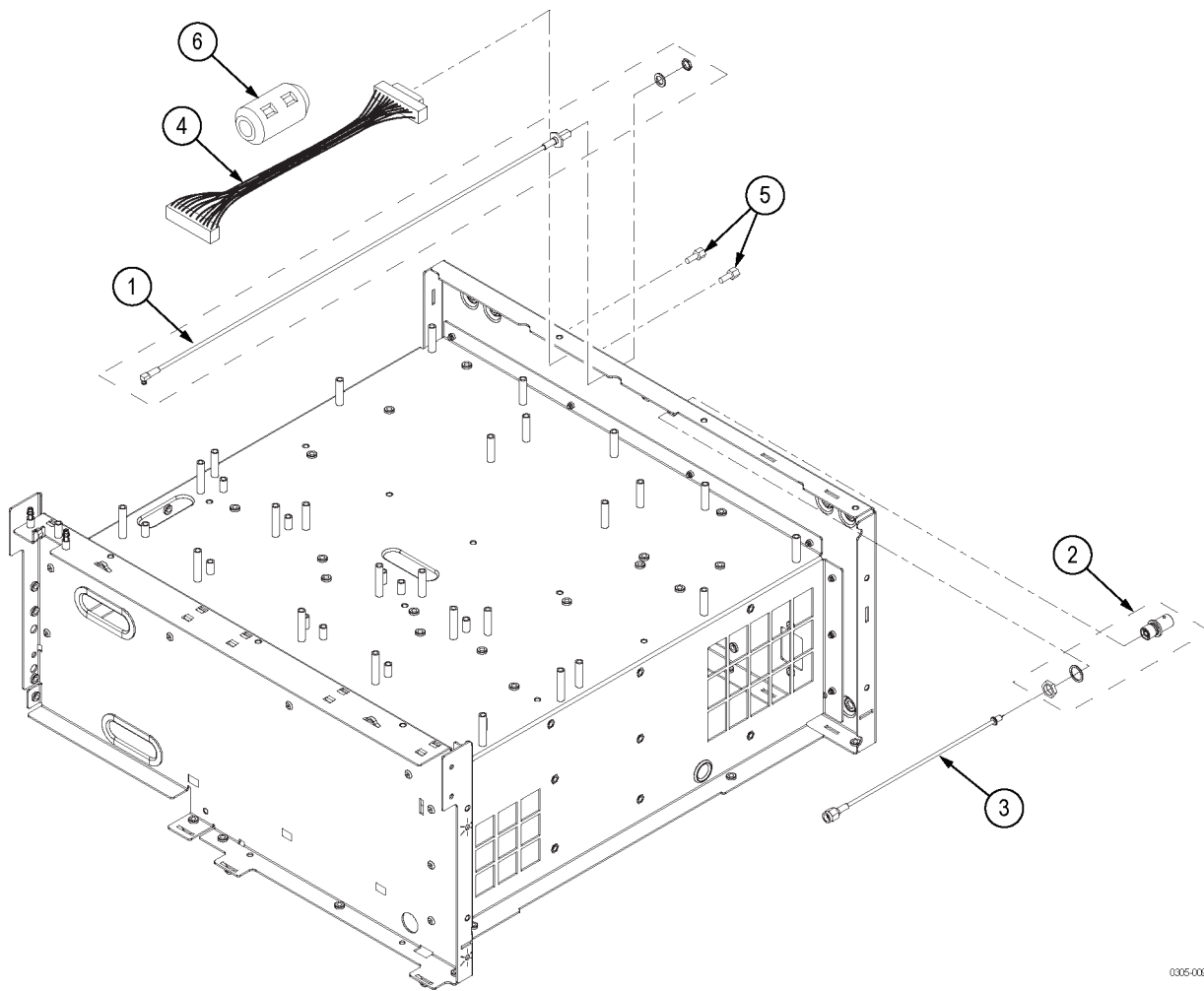

Figure 5-21: Relay unit

Table 5-22: Replaceable parts list – rear connectors

Fig. & index number	Tektronix part number	Serial no. effective	Serial no. discont'd	Qty	Name & description
5-22-					REAR CONNECTOR
-1	174-5323-01			1	CABLE ASSY ELEC: RF,COAX,50 OHM,9.5IN L,SMA-R STR PANEL MOUNT TO SMP-R RTANG,FLEX COAX CABLE
-2	131-8054-00			2	CONN,RF,JACK; BNC,PNL,50 OHM,FEMALE,STR,PELTOLA/PNL MNT, SILVER ALLOY, 0.576 MLG X 0.366 TERMN,0.375-32 THD, D-FLAT
-3	174-5294-00			2	CABLE ASSY ELEC: RF,COAX,7IN L,50 OHM,SMA-P STR,PELTOLA, FLEX COAX CABLE
-4	174-5680-00			1	CABLE ASSY ELEC: EVENT, 7.88IN L,BOARD TO REAR PANEL,15P EVENT CONN TO 16P HEADER CONN, SAFETY CONTROLLED (AWG7000C SERIES)
-5	214-3903-00			2	SCREW, JACK; 4-40 X 0.312 LONG, 0.188 H HEX HEAD STAND OFF, 4-40 INT THD, X 0.312 THD EXT 4-40, STEEL, ZINC PLATED (AWG7000C SERIES)
-6	276-0424-00			1	CORE,EMI; EMI SUPPRESSION FERRITE;SPLIT ROUND CABLE,IMPE 360 OHM AT 300MHZ, .357 MAX CABLE, STEWARD PN 28A2736-0A2 (AWG7000C SERIES)



0305-009

Figure 5-22: Rear connectors