

Keithley Instruments

28775 Aurora Road
 Cleveland, Ohio 44139
 1-800-935-5595
tek.com/keithley

Introduction

The Keithley Instruments Model 2461-SYS is an interactive SourceMeter® instrument specifically for use in Keithley S535 parametric test systems. The 2461-SYS is a modified version of the Model 2461 System SourceMeter instrument, with fewer high-current ranges.

This document describes the existing 2461 user documentation and the differences between the 2461-SYS and the 2461.

User documentation for the 2461-SYS

The 2461-SYS operates the same way the 2461 does, except in applications that use current ranges higher than 1 A. For detailed information about how to use the 2461-SYS, refer to the following manuals (included with the Keithley Test Environment (KTE) software installation, on the KTE software DVD, and available for download at tek.com/keithley).

NOTE

When using the 2461 documentation, remember that references to the higher current ranges and extended operating areas do not apply to your instrument.

Model 2461 documentation includes:

- Model 2461 Reference Manual (part number 2461-901-01)
- Model 2461 User's Manual (part number 2461-900-01)
- Model 2461 Quick Start Guide (part number 2461-903-01)
- Model 2461 Calibration and Adjustment Manual (part number 2461-905-01)

Differences between models

The following topics describe the differences between the 2461-SYS and 2461 instruments.

Current and voltage ranges

The 2461-SYS has fewer current ranges than the 2461, as shown in the following table.

| | 1 μ A | 10 μ A | 100 μ A | 1 mA | 10 mA | 100 mA | 1 A | 4 A | 5 A | 7 A | 10 A* |
|----------|-----------|------------|-------------|------|-------|--------|-----|-----|-----|-----|-------|
| 2461-SYS | ✓ | ✓ | ✓ | ✓ | ✓ | ✓ | ✓ | | | | |
| 2461 | ✓ | ✓ | ✓ | ✓ | ✓ | ✓ | ✓ | ✓ | ✓ | ✓ | ✓ |

* Pulse operation only



The voltage ranges for the 2461-SYS are the same as the 2461.

| | 200 mV | 2 V | 7 V | 10 V | 20 V | 100 V |
|----------|--------|-----|-----|------|------|-------|
| 2461-SYS | ✓ | ✓ | ✓ | ✓ | ✓ | ✓ |
| 2461 | ✓ | ✓ | ✓ | ✓ | ✓ | ✓ |

Operating boundaries

The 2461-SYS has different operating boundaries than the 2461, as shown in the following figures.

Figure 1: 2461-SYS operating boundaries

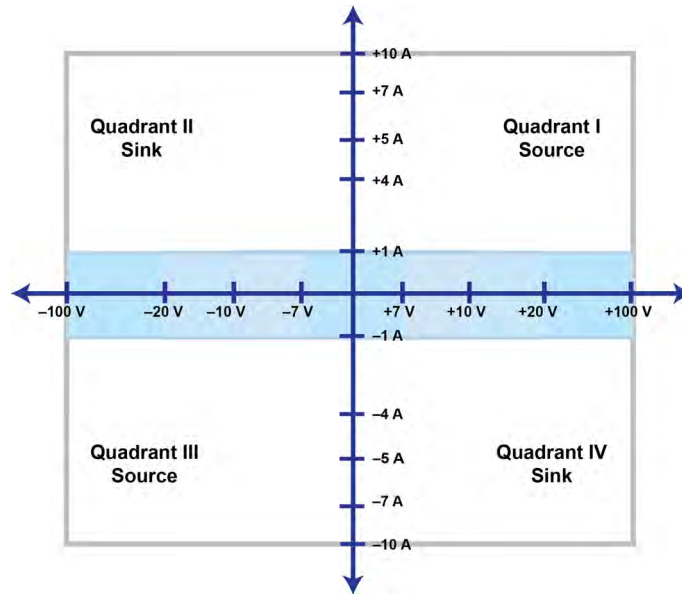
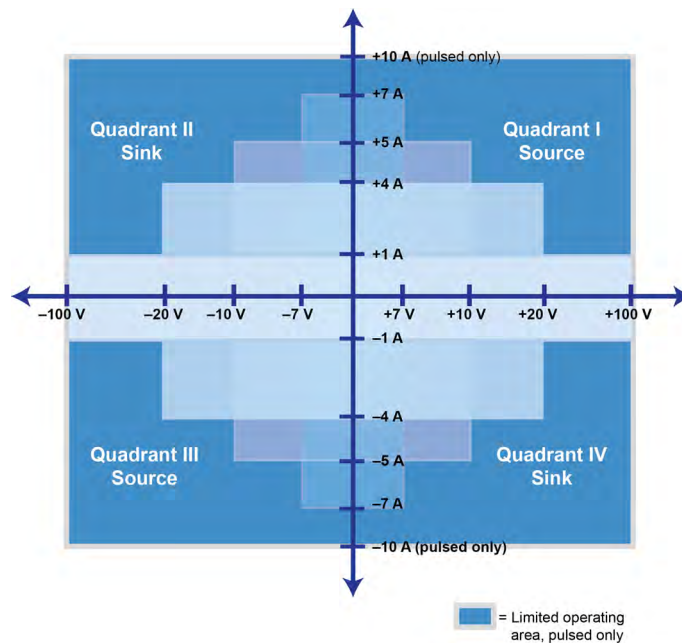

Figure 2: 2461 operating boundaries



Physical differences

Because the 2461-SYS is intended for use in a racked parametric test system, it does not have a handle, bumpers, or feet. As a result, the dimensions and weight of the instrument are slightly different than the 2461 (with handle, bumpers, and feet).

The following figures show the dimensions of the 2461-SYS.

Figure 3: 2461-SYS dimensions

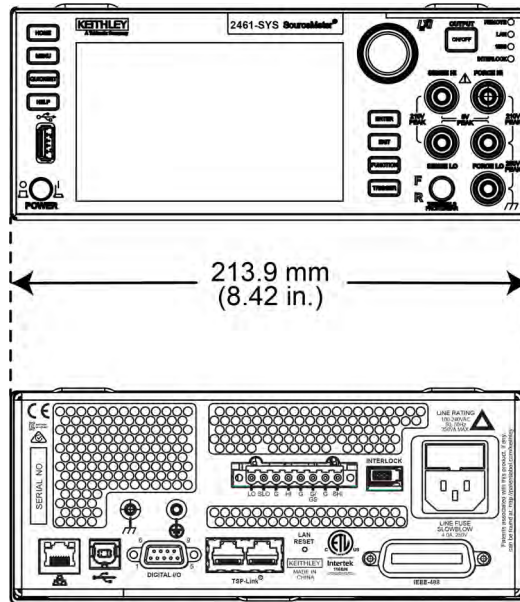
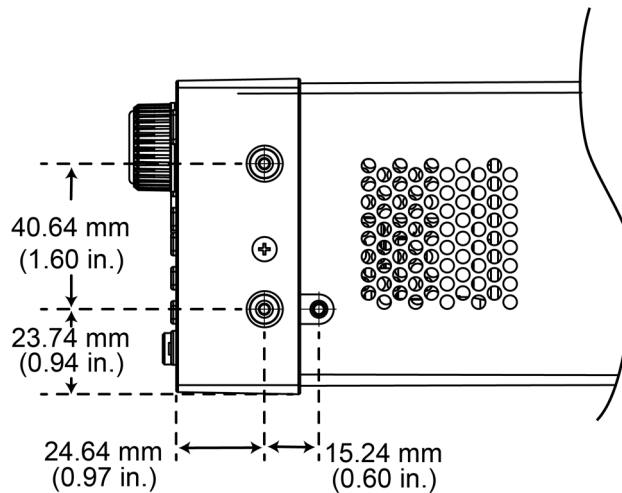

Figure 4: 2461-SYS mounting screw dimensions



The 2461-SYS weighs 4.35 kg (9.6 lb); a 2461 with handles and bumpers weighs 4.75 kg (10.5 lb).

Default settings differences

The 2461-SYS has a few default settings that are different from the 2461 defaults (see the following table).

| Default setting | 2461-SYS | 2461 |
|------------------|----------------|-----------------|
| Active terminals | Rear terminals | Front terminals |
| 2-wire or 4-wire | 4-wire | 2-wire |
| Popup warnings | Off | On |

Firmware differences

ATTENTION

The 2461-SYS has its own version of firmware that is not interchangeable with the 2461. Be sure you use the correct file when you update the firmware on the 2461-SYS.

The firmware for the 2461-SYS is named differently, with a prefix that begins with `ki_1642` (2461 backwards). For example, a firmware image for the 2461-SYS might be named `ki_1642_v1_6_6k.upg`.

The following safety precautions should be observed before using this product and any associated instrumentation. Although some instruments and accessories would normally be used with nonhazardous voltages, there are situations where hazardous conditions may be present.

This product is intended for use by personnel who recognize shock hazards and are familiar with the safety precautions required to avoid possible injury. Read and follow all installation, operation, and maintenance information carefully before using the product. Refer to the user documentation for complete product specifications.

If the product is used in a manner not specified, the protection provided by the product warranty may be impaired.

The types of product users are:

Responsible body is the individual or group responsible for the use and maintenance of equipment, for ensuring that the equipment is operated within its specifications and operating limits, and for ensuring that operators are adequately trained.

Operators use the product for its intended function. They must be trained in electrical safety procedures and proper use of the instrument. They must be protected from electric shock and contact with hazardous live circuits.

Maintenance personnel perform routine procedures on the product to keep it operating properly, for example, setting the line voltage or replacing consumable materials. Maintenance procedures are described in the user documentation. The procedures explicitly state if the operator may perform them. Otherwise, they should be performed only by service personnel.

Service personnel are trained to work on live circuits, perform safe installations, and repair products. Only properly trained service personnel may perform installation and service procedures.

Keithley products are designed for use with electrical signals that are measurement, control, and data I/O connections, with low transient overvoltages, and must not be directly connected to mains voltage or to voltage sources with high transient overvoltages. Measurement Category II (as referenced in IEC 60664) connections require protection for high transient overvoltages often associated with local AC mains connections. Certain Keithley measuring instruments may be connected to mains. These instruments will be marked as category II or higher.

Unless explicitly allowed in the specifications, operating manual, and instrument labels, do not connect any instrument to mains.

Exercise extreme caution when a shock hazard is present. Lethal voltage may be present on cable connector jacks or test fixtures. The American National Standards Institute (ANSI) states that a shock hazard exists when voltage levels greater than 30 V RMS, 42.4 V peak, or 60 VDC are present. A good safety practice is to expect that hazardous voltage is present in any unknown circuit before measuring.

Operators of this product must be protected from electric shock at all times. The responsible body must ensure that operators are prevented access and/or insulated from every connection point. In some cases, connections must be exposed to potential human contact. Product operators in these circumstances must be trained to protect themselves from the risk of electric shock. If the circuit is capable of operating at or above 1000 V, no conductive part of the circuit may be exposed.

Do not connect switching cards directly to unlimited power circuits. They are intended to be used with impedance-limited sources. NEVER connect switching cards directly to AC mains. When connecting sources to switching cards, install protective devices to limit fault current and voltage to the card.

Before operating an instrument, ensure that the line cord is connected to a properly-grounded power receptacle. Inspect the connecting cables, test leads, and jumpers for possible wear, cracks, or breaks before each use.

When installing equipment where access to the main power cord is restricted, such as rack mounting, a separate main input power disconnect device must be provided in close proximity to the equipment and within easy reach of the operator.

For maximum safety, do not touch the product, test cables, or any other instruments while power is applied to the circuit under test. ALWAYS remove power from the entire test system and discharge any capacitors before: connecting or disconnecting cables or jumpers, installing or removing switching cards, or making internal changes, such as installing or removing jumpers.

Do not touch any object that could provide a current path to the common side of the circuit under test or power line (earth) ground. Always make measurements with dry hands while standing on a dry, insulated surface capable of withstanding the voltage being measured.

For safety, instruments and accessories must be used in accordance with the operating instructions. If the instruments or accessories are used in a manner not specified in the operating instructions, the protection provided by the equipment may be impaired.

Do not exceed the maximum signal levels of the instruments and accessories. Maximum signal levels are defined in the specifications and operating information and shown on the instrument panels, test fixture panels, and switching cards.

When fuses are used in a product, replace with the same type and rating for continued protection against fire hazard.

Chassis connections must only be used as shield connections for measuring circuits, NOT as protective earth (safety ground) connections.

If you are using a test fixture, keep the lid closed while power is applied to the device under test. Safe operation requires the use of a lid interlock.

The  symbol on an instrument means caution, risk of hazard. The user must refer to the operating instructions located in the user documentation in all cases where the symbol is marked on the instrument.

The  symbol on an instrument means warning, risk of electric shock. Use standard safety precautions to avoid personal contact with these voltages.

The  symbol on an instrument shows that the surface may be hot. Avoid personal contact to prevent burns.

The  symbol indicates a connection terminal to the equipment frame.

If this  symbol is on a product, it indicates that mercury is present in the display lamp. Please note that the lamp must be properly disposed of according to federal, state, and local laws.

The **WARNING** heading in the user documentation explains hazards that might result in personal injury or death. Always read the associated information very carefully before performing the indicated procedure.

The **CAUTION** heading in the user documentation explains hazards that could damage the instrument. Such damage may invalidate the warranty.

The **CAUTION** heading with the  symbol in the user documentation explains hazards that could result in moderate or minor injury or damage the instrument. Always read the associated information very carefully before performing the indicated procedure. Damage to the instrument may invalidate the warranty.

Instrumentation and accessories shall not be connected to humans.

Before performing any maintenance, disconnect the line cord and all test cables.

To maintain protection from electric shock and fire, replacement components in mains circuits — including the power transformer, test leads, and input jacks — must be purchased from Keithley. Standard fuses with applicable national safety approvals may be used if the rating and type are the same. The detachable mains power cord provided with the instrument may only be replaced with a similarly rated power cord. Other components that are not safety-related may be purchased from other suppliers as long as they are equivalent to the original component (note that selected parts should be purchased only through Keithley to maintain accuracy and functionality of the product). If you are unsure about the applicability of a replacement component, call a Keithley office for information.

Unless otherwise noted in product-specific literature, Keithley instruments are designed to operate indoors only, in the following environment: Altitude at or below 2,000 m (6,562 ft); temperature 0 °C to 50 °C (32 °F to 122 °F); and pollution degree 1 or 2.

To clean an instrument, use a cloth dampened with deionized water or mild, water-based cleaner. Clean the exterior of the instrument only. Do not apply cleaner directly to the instrument or allow liquids to enter or spill on the instrument. Products that consist of a circuit board with no case or chassis (e.g., a data acquisition board for installation into a computer) should never require cleaning if handled according to instructions. If the board becomes contaminated and operation is affected, the board should be returned to the factory for proper cleaning/servicing.

Safety precaution revision as of June 2017.