

**Keithley Instruments**

28775 Aurora Road  
Cleveland, Ohio 44139  
1-800-833-9200  
[tek.com/keithley](http://tek.com/keithley)

## Introduction

The 3731 is a two-pole, 6 row by 16 column reed relay matrix card. By using high-speed reed relays with actuation times of 0.5 ms, this card meets the requirements of demanding throughput applications while offering users the additional benefit of long life, exceeding one billion operations. The card can connect up to six differential instrument channels to any combination of 16 devices under test (DUTs). Any row can be connected to the Series 3700A mainframe backplane by using the analog backplane connection relays. This allows for easy matrix column expansion. A matrix of up to 6 rows by 96 columns can be supported within a single 3706A mainframe with six 3731 cards.

The 3731 uses two 50-pin male D-sub connectors for signal connections. For screw-terminal connections, use the detachable 3731-ST accessory. For more information regarding available cards and accessories, refer to the *Series 3700A System Switch/Multimeter and Plug-in Cards* datasheet, available at [tek.com/keithley](http://tek.com/keithley).

The 3731 card is shown in the following figure.

**Figure 1: Model 3731 6×16 High-Speed Card**

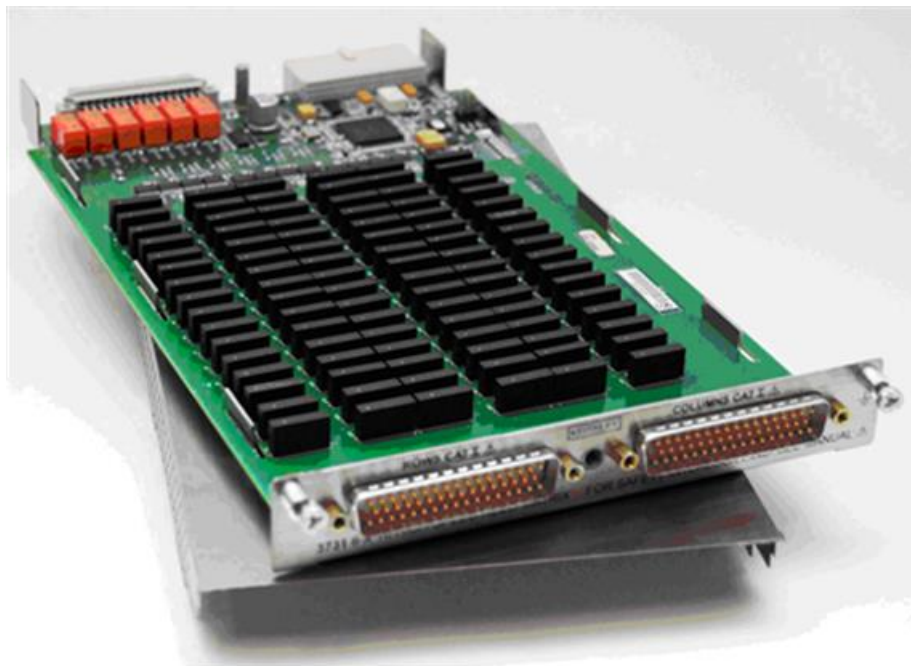

*Item shipped may vary from model pictured here.*

This document describes how to install the plug-in card and make connections to it. For information on scanning, and on reading, writing, and controlling channels, refer to the *Series 3700A System Switch/Multimeter Reference Manual*, available at [tek.com/keithley](http://tek.com/keithley).



## Safety precautions for connections

---

### **WARNING**

Shock hazard. To prevent electric shock that could result in serious injury or death, comply with these safety precautions.

Connection information for plug-in cards is intended for qualified service personnel. Do not attempt to connect devices under test (DUTs) or external circuitry to a plug-in card unless you are qualified.

As described in the International Electrotechnical Commission (IEC) Standard IEC 60664, the Series 3700A is Installation Category O and signal lines must not be directly connected to AC mains.

Before making or breaking any connections to the plug-in card, make sure the Series 3700A instrument power is turned off and power is removed from all external circuitry.

Do not connect signals that will exceed the maximum specifications of any installed plug-in card. If the rear analog backplane connector of the instrument and the plug-in card terminals are connected at the same time, the test lead insulation must be rated to the highest voltage that is connected. For example, if 300 V is connected to the analog backplane connector, the test lead insulation for the plug-in card must also be rated for 300 V.

Dangerous arcs of an explosive nature in a high-energy circuit can cause severe personal injury or death if contacted. If the multimeter is connected to a high-energy circuit when set to a current range, low-resistance range, or any other low-impedance range, the circuit is virtually shorted. Dangerous arcing can result, even when the multimeter is set to a voltage range, if the minimum voltage spacing is reduced in the external connections.

Use test leads that are fully insulated. Use only test leads that can be connected to the circuit (for example, alligator clips and spade lugs) for hands-off measurements. Do not use test leads that decrease voltage spacing. These diminish arc protection and create a hazardous condition.

---

## Card installation

---

### **WARNING**

Slot covers must be installed on unused slots to prevent personal contact with high-voltage circuits. Failure to recognize and observe standard safety precautions could result in personal injury or death due to electric shock.

---

**To install a switching card into the instrument mainframe:**

1. Turn the instrument off.
2. Position the instrument so that you are facing the rear panel.
3. Disconnect the power line cord and any other cables connected to the rear panel.
4. Remove the slot cover plate from the mainframe slot. Retain the plate and screws for future use.
5. With the top cover of the switching card facing up, align the card edge into the card guide of the slot, as shown in the following figure.
6. Slide in the card. For approximately the last ¼ inch, press in firmly to seat the card connector to the mainframe connector.
7. On each side of the card, there is a mounting screw. Use a flat-bladed screwdriver to tighten the two mounting screws to secure the card to the mainframe. Do not overtighten.
8. Reconnect the power line cable and any other cables to the rear panel.
9. Turn the instrument on.

**Figure 2: Module installation**

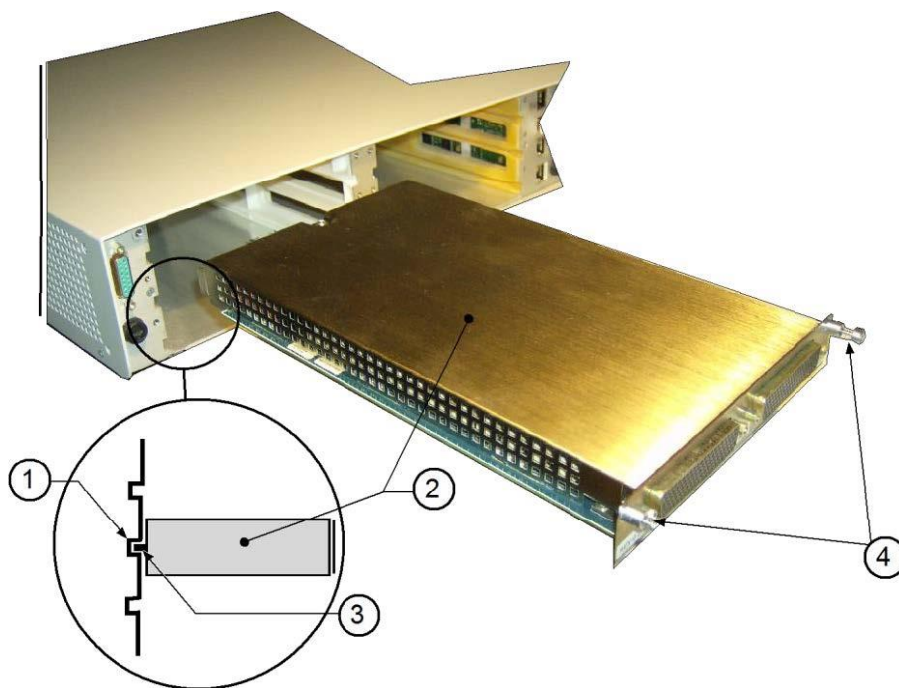

*Item shipped may vary from model pictured here.*

Item	Description
1	Card guide (part of mainframe)
2	Card
3	Card edge (part of card)
4	Mounting screw (part of card)

## Verify card installation

**To verify that the card was properly installed:**

1. If the 3700A is controlled remotely (REM is displayed), press **EXIT** to switch control to local.
2. On the 3700A front panel, press **SLOT**. The name and firmware version of the instrument is displayed.
3. Press **SLOT** again. The name and firmware version of the card in slot 1 is displayed.
4. If you have more than one card installed, continue to press **SLOT** until the slot you installed is displayed.
5. Confirm the name and firmware version.
6. Press **EXIT** to return to the operating display.

## Connection information

The 3731 uses two 50-pin D-sub plugs for signal connections. Use the detachable Model 3731-ST accessory for screw-terminal connections.

The following notes and figure show the J3 and J4 D-sub pin connections for the 3731.

Pin connector notes:

- **J3:** Left connector
- **J4:** Right connector
- **Blue (shaded):** Connections used by the screw-terminal accessory
- **Gray X connections:** Unavailable
- **Backplane interlock:** Actuate by connecting +ILK to -ILK

**Figure 3: Model 3731 pin connections**

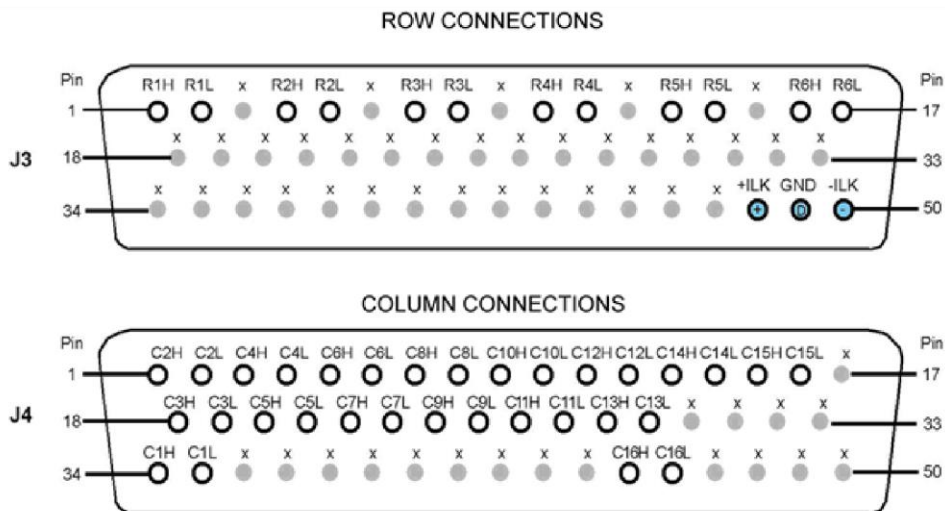

## Schematic

The following figure is a relay schematic for this card.

Figure 4: Schematic

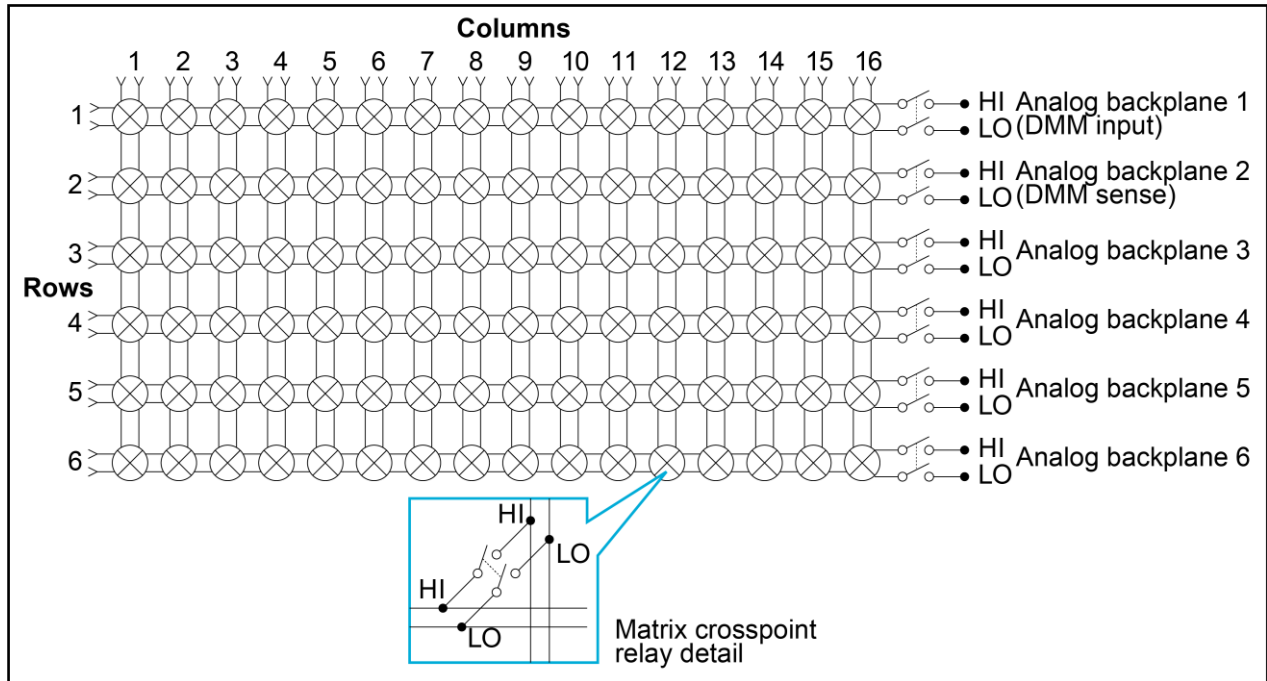

The channels on this plug-in card are matrix channels. Unlike multiplexer (MUX) channels, matrix channels do not have a DMM configuration associated with them. Therefore, specifying a matrix channel in the channel list parameter to the `dmm.setconfig()` function generates an error. To connect a DMM configuration to matrix channels, create a channel pattern with the appropriate channels and analog backplane relays needed.

## NOTE

For channel patterns, the system does not verify if the pathway is correct or if the correct analog backplane relays are specified for the selected function.

## Pseudocards

You can perform open, close, and scan operations and configure your system without having a switch card installed in your instrument. If you are connected to a remote interface, you can assign a pseudocard to an empty switch card slot.

You cannot set up a pseudocard from the front panel. However, once pseudocard configuration is complete, you can take the instrument out of remote mode and use the front panel to control the pseudocard. Press the **EXIT** key to take the instrument out of remote mode. The model number of a pseudocard is the same as the model number of an actual card (except for 3732 cards).

When the instrument is turned off, the pseudocard settings are lost and the pseudocard is no longer assigned to the slot. To preserve the pseudocard setting through a power cycle, use a saved setup or a configuration script. The setup or script retains the model number of the card installed in each slot, including pseudocards.

For additional information on pseudocards, refer to the *Series 3700A System Switch/Multimeter Reference Manual* at [tek.com/keithley](http://tek.com/keithley).

### 3731 pseudocard

You can install a pseudocard in any empty slot. With the 3731 pseudocard installed, the instrument operates as if a 3731 card is installed in the slot. This allows you to configure a scan and exercise its operation before the plug-in card is installed in the 3700A instrument.

In the following code examples, replace *slot* with the slot number (1 to 6).

**To set a slot to use a 3731 pseudocard, send:**

```
slot[slot].pseudocard = 3731
```

**To query the pseudocard, send:**

```
print(slot[slot].pseudocard)
```

**To set a slot to stop using a pseudocard, send:**

```
slot[slot].pseudocard = slot.PSEUDO_NONE
```

---

## NOTE

The revision level of a pseudocard is always returned as 00.00 a.

---

You can query the slot attributes to determine the capabilities of the installed switching modules. For example, send the following query to determine if slot 1 supports 4-wire commonside ohms channels:

```
print(slot[1].commonsideohms)
```

Refer to the *Series 3700A System Switch/Multimeter Reference Manual* for more information about using queries at [tek.com/keithley](http://tek.com/keithley).

## Screw-terminal accessory

### NOTE

The Model 3731-ST screw-terminal accessory has a chassis ground connection for connecting a cable shield.

The 3731-ST screw-terminal accessory is shown in the following figure. The figure indicates the terminals as high or low to help you configure your cable assembly.

**Figure 5: Model 3731 Screw-Terminal Accessory**

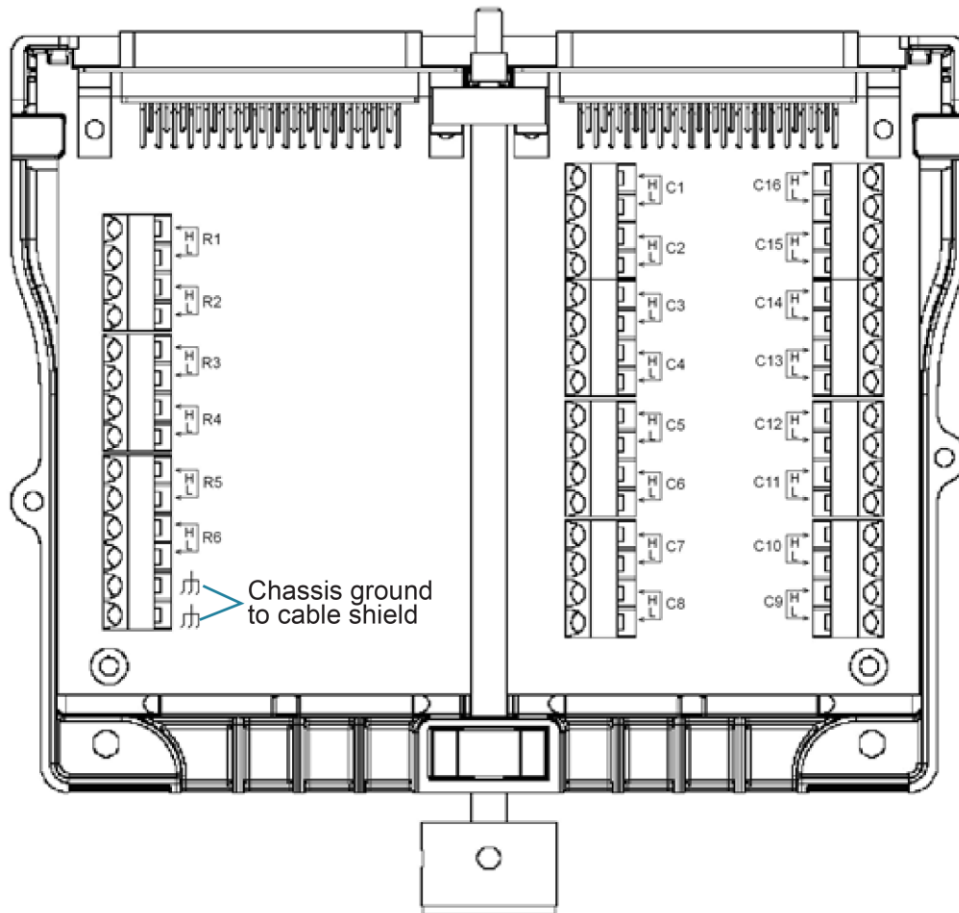



## Wire the screw-terminal accessory

These instructions describe how to connect wiring to a Series 3700A screw-terminal accessory.

---

### CAUTION

It is not necessary to remove a circuit board from its enclosure to wire the screw-terminal accessory. Avoid handling circuit board surfaces and terminal blocks. Contaminants from hands may degrade screw-terminal accessory performance.

---

#### To wire the screw-terminal accessory:

1. Loosen the slotted captive screws (1) on the top cover.
2. Slide the top cover (2) away from the retaining tab (3), as shown in the following figure.

**Figure 6: Remove the top cover of the screw-terminal accessory**

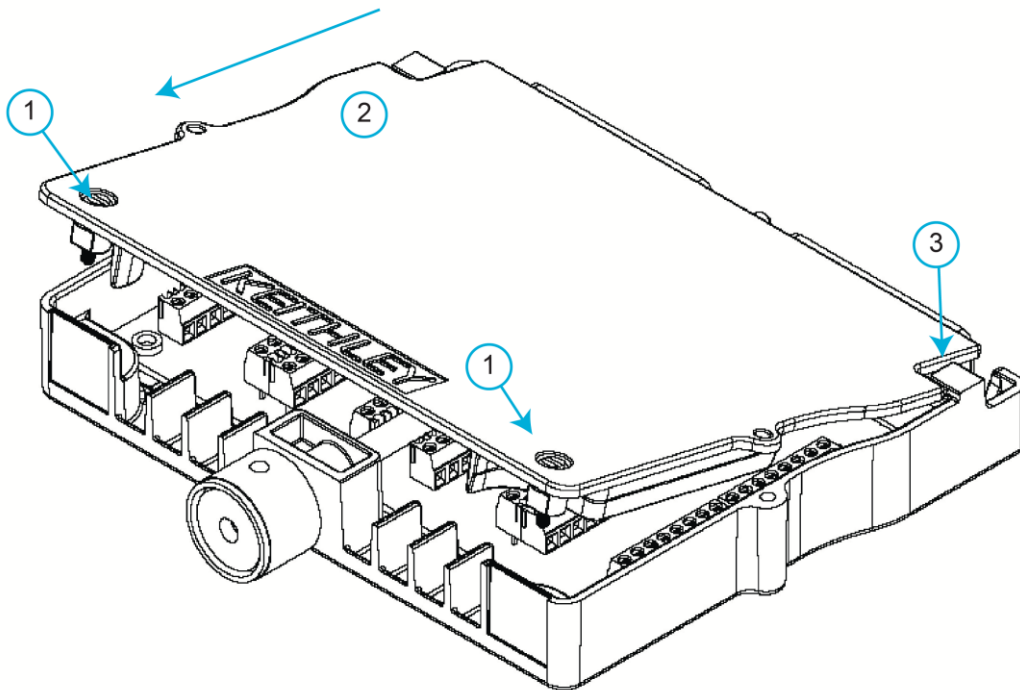

3. If your accessory includes insertable overlays, select the correct overlay and press it into place inside the screw-terminal accessory.



- As shown in the following figure, route your wiring through the slots at the rear of the screw-terminal accessory and connect it to the wiring terminals as described in [Connection information](#) (on page 4).

**Figure 7: Routing and securing cables with ties**

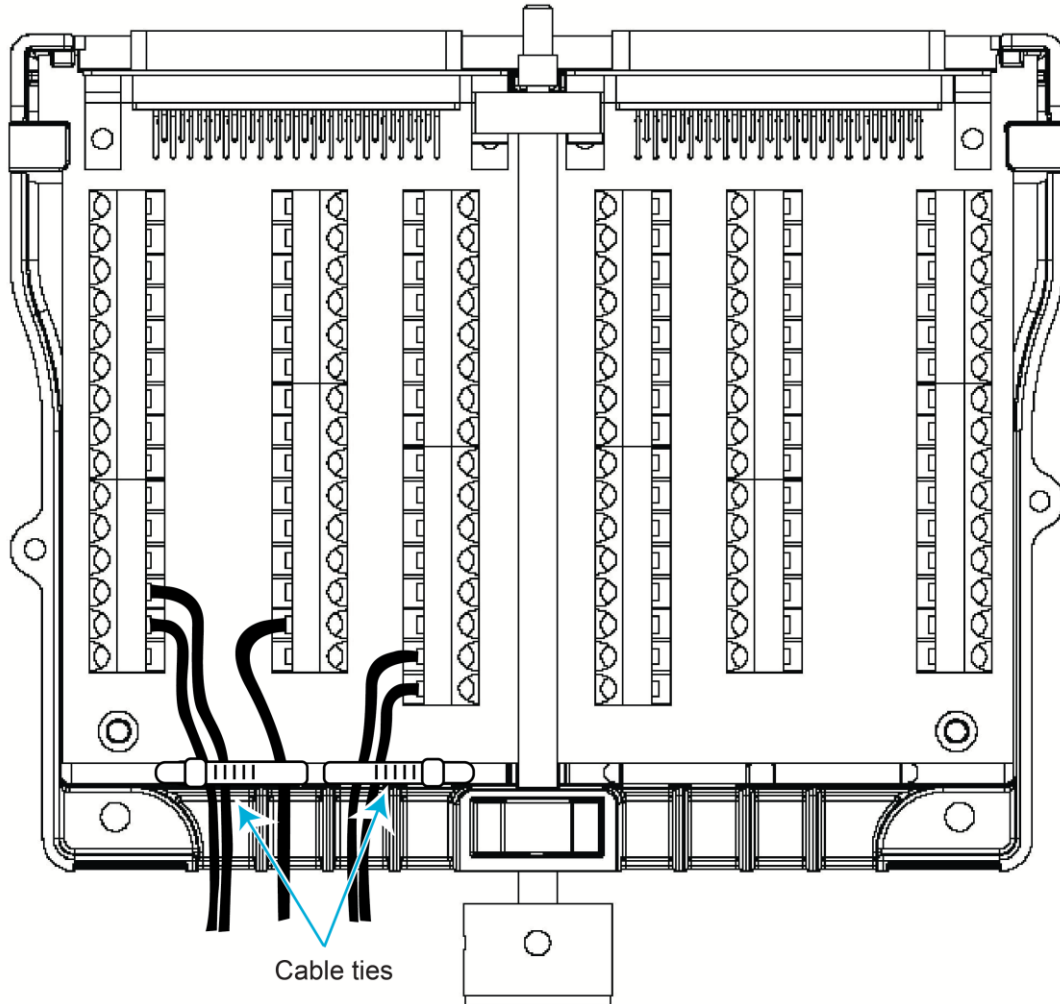

- When all wires have been connected, use small cable ties to secure the wires and provide strain relief, as shown in the previous figure. Pass the cable tie in and out of the small holes in the base of the screw-terminal assembly and around your wiring before pulling the cable tie tight.
- Align the top cover with the circuit board.

7. Slide the cover forward (1) and beneath the retaining tab (2), as shown in the following figure.
8. Fasten the two slotted captive screws (3).

**Figure 8: Install the screw-terminal assembly top cover**

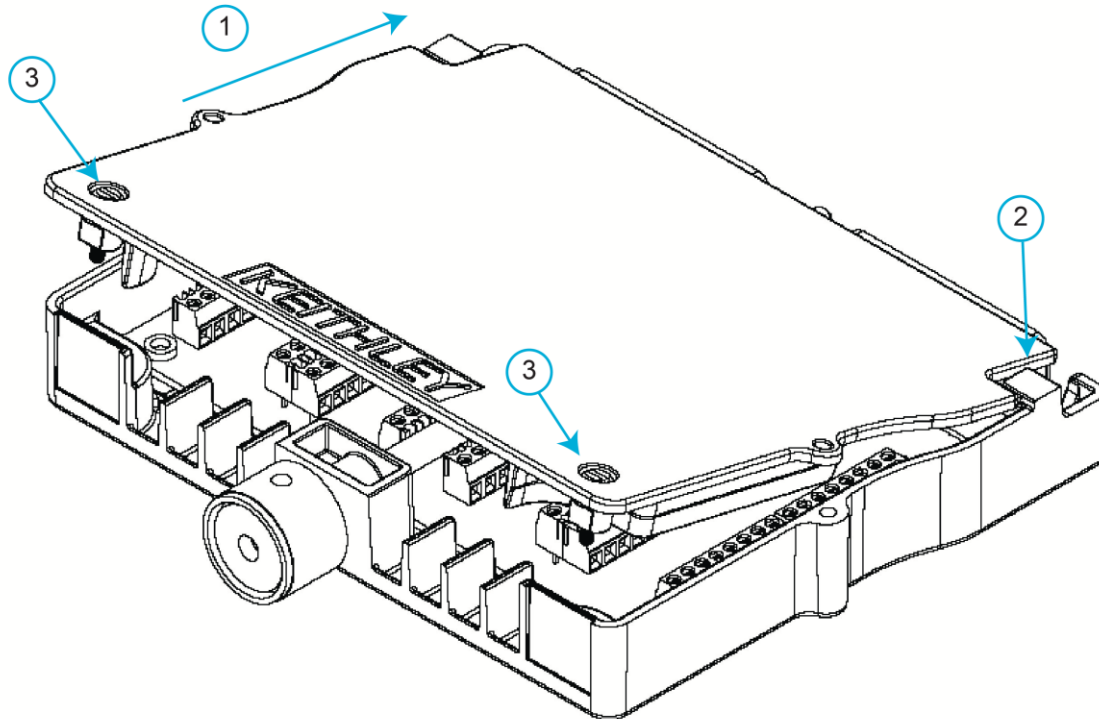

## Install the screw-terminal accessory

---

### **⚠ WARNING**

Before using a screw-terminal assembly with an installed plug-in card, verify that the card is properly installed in the 3700A instrument and that the mounting screws are tightly fastened. If the mounting screws are not properly connected, an electrical shock hazard may be present.

---

### **NOTE**

To use more than two 3700A screw-terminal accessories in a rack-mount installation, use the terminal support bracket included in the Model 4288-10 Rear Support Mount Kit. For more information about the rack-mount kit, refer to Keithley document *Model 4288-10 Rear Support Rack-Mount Kit Assembly and Mounting Instructions*, available on [tek.com/keithley](http://tek.com/keithley).

---

#### **To install the screw-terminal accessory on the 3700A plug-in card:**

1. Remove all power from the 3700A instrument.

2. Make sure that the mounting screws (1 in the following figure) on the installed plug-in card are secure.

**Figure 9: Check 3700A card mounting screws**

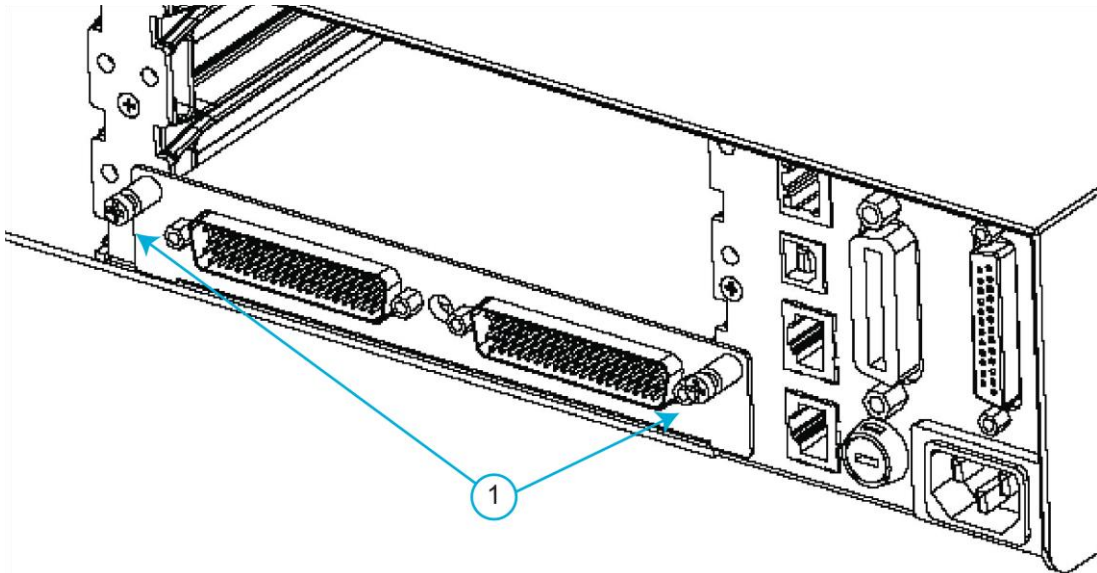

3. Align the screw-terminal assembly D-sub connectors with the connectors on the installed plug-in card, as shown in the following figure.
4. Press to seat the D-sub connectors.

**Figure 10: Connect the screw-terminal accessory**

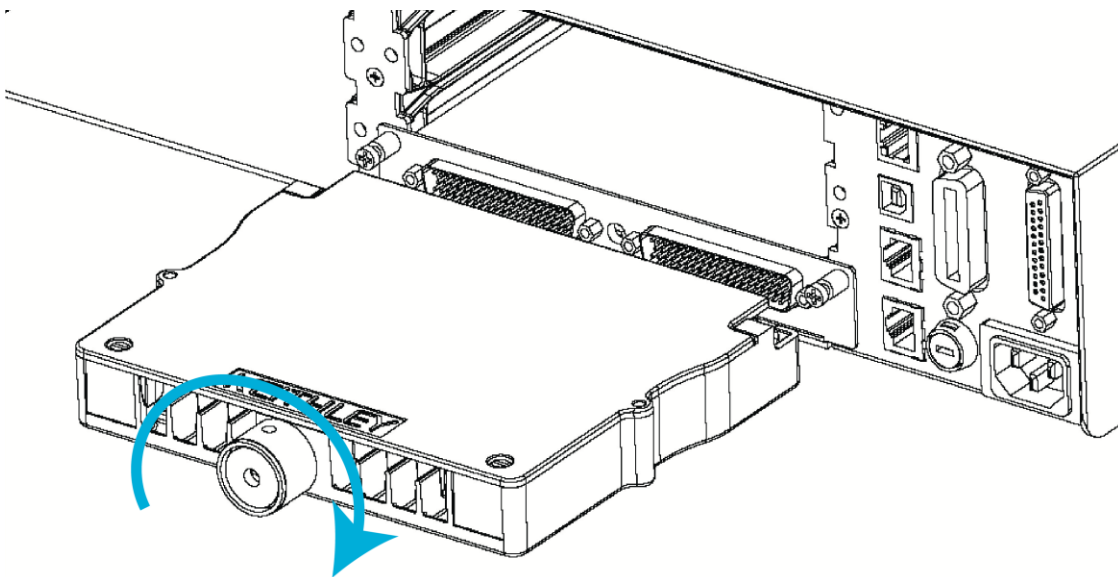

5. Turn the knob on the screw-terminal assembly clockwise by hand, as shown in the previous figure, until it is firmly engaged. You may need to use a slotted screwdriver to tighten the knob.

## CAUTION

To prevent damage to the card, do not overtighten the knob.

## Remove the screw-terminal accessory

**To remove a screw-terminal accessory from an installed plug-in card:**

1. Remove all power from the 3700A instrument.
2. Turn the knob on the screw-terminal accessory counter-clockwise until it is completely disengaged. You may need to use a slotted screwdriver to loosen the knob.
3. Pull the screw-terminal accessory away from the plug-in card D-sub connectors.

## Model 3721-MTC-3 cable

The 3721-MTC-3 cable is a 50-pin cable assembly that is 3.0 m (10 ft) long and terminated with a D-sub plug on one end and a D-sub jack on the other end.

Figure 11: Model 3721-MTC-3 cable

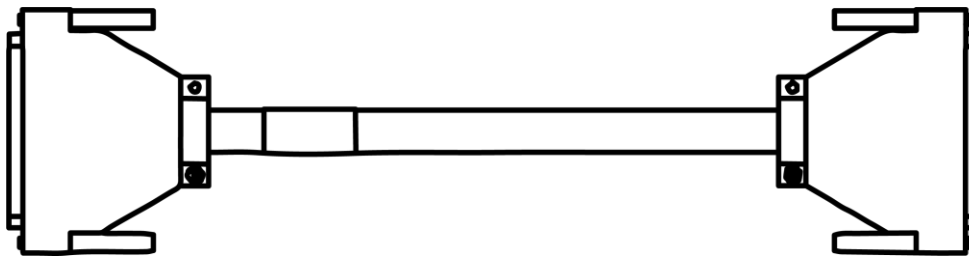

---

### **⚠ WARNING**

To prevent electrical shock, observe the following safety precautions:

- Connect both ends of the cable before applying any power to the system.
  - Remove all power in the system before connecting the cable to a switching module or external circuitry.
  - Connect both D-sub connector shells of this cable to a safety earth ground. A shock hazard exists when voltage levels greater than 30 V<sub>RMS</sub>, 42.4 V<sub>PEAK</sub>, or 60 V DC are present.
- 

## 3721-MTC-3 characteristics

Cable maximum signal levels: 300 V DC or 300 V<sub>RMS</sub>

Maximum current rating:

- **Single conductor:** 4.4 A
- **Multiple conductors:** 2.2 A per wire
- **Conductor gauge:** 22 AWG

## Pin number identification

Pin numbers for the Model 3721-MTC-3 D-sub cables are shown in the following figure and table.

Connect the drain wire to the shield at both ends of the 3721-MTC-3 cable.

**Figure 12: Model 3721-MTC-3 connectors**

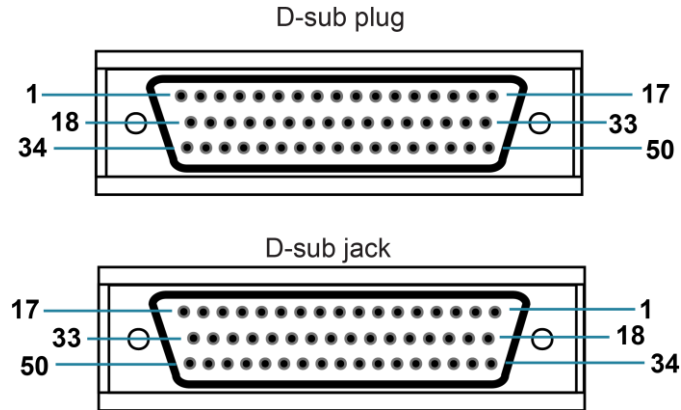

### Model 3721-MTC-3 pin number identification

CONN 1 pin	Color	CONN 2 pin
1	Black	1
2	White	2
3	Red	3
4	Green	4
5	Orange	5
6	Blue	6
7	White/black	7
8	Red/black	8
9	Green/black	9
10	Orange/black	10
11	Blue/black	11
12	Black/white	12
13	Red/white	13
14	Green/white	14
15	Blue/white	15
16	Black/red	16
17	White/red	17
18	Orange/red	18
19	Blue/red	19
20	Red/green	20
21	Orange/green	21
22	Black/white/red	22
23	White/black/red	23
24	Red/black/white	24
25	Green/black/white	25

CONN 1 pin	Color	CONN 2 pin
26	Orange/black/white	26
27	Blue/black/white	27
28	Black/red/green	28
29	White/red/green	29
30	Red/black/green	30
31	Green/black/orange	31
32	Orange/black/green	32
33	Blue/white/orange	33
34	Black/white/orange	34
35	White/red/orange	35
36	Orange/white/blue	36
37	White/red/blue	37
38	Black/white/green	38
39	White/black/green	39
40	Red/white/green	40
41	Green/white/blue	41
42	Orange/red/green	42
43	Blue/red/green	43
44	Black/white/blue	44
45	White/black/blue	45
46	Red/white/blue	46
47	Green/orange/red	47
48	Orange/red/blue	48
49	Blue/orange/red	49
50	Black/orange/red	50

## Hardware interlocks

This plug-in card can switch high-voltage signals. To prevent exposure to hazardous voltages, the plug-in card includes a hardware interlock. The hardware interlocks are present on the plug-in card and are designed to keep the plug-in card disconnected from the 3700A backplane. When the interlock circuit is disengaged, no measurements can be made through a plug-in card, but channel relays can continue to operate.

The following figure is a simplified schematic of the interlock circuit on the plug-in card.

**Figure 13: Simplified interlock circuit**

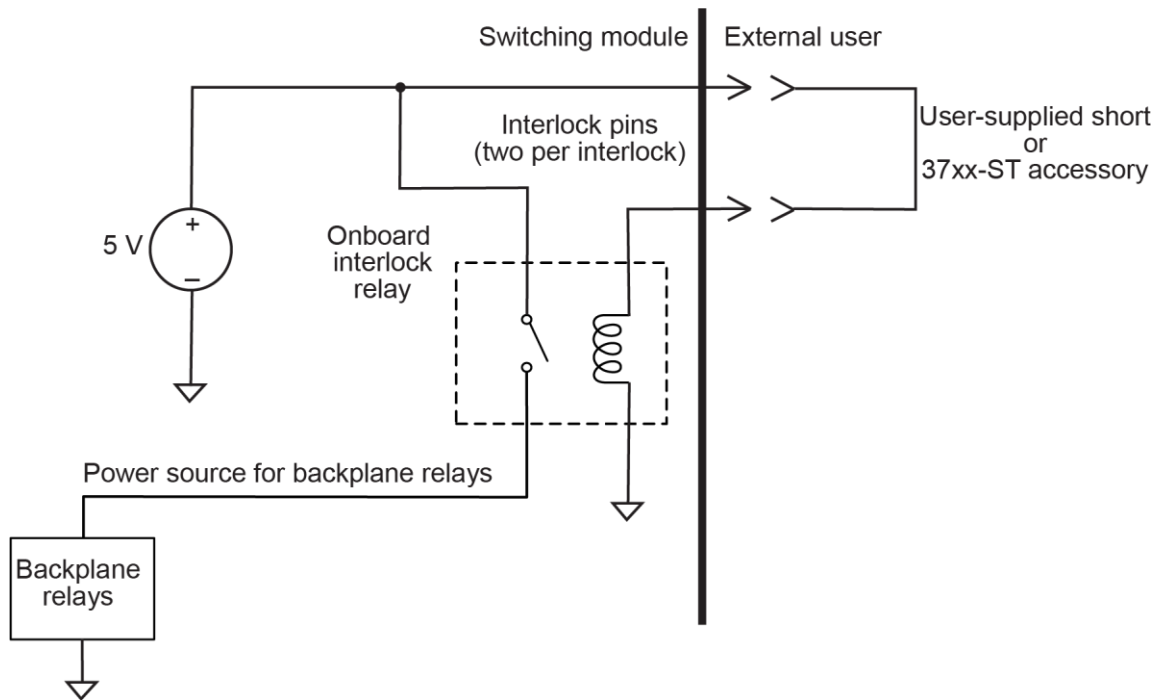

## 3731 Interlock pin numbers

The 3731 uses interlock circuit matrix #1, interlock pins 38 and 50. It affects backplane relays n911 to n916.

### CAUTION

To prevent instrument damage or loss of functionality, make sure high-voltage analog signals are not wired to the interlock pins.

## Engage hardware interlocks

To engage the hardware interlocks, you must provide a low-resistance path between the two applicable interlock pins, as shown in the figure in [Hardware interlocks](#) (on page 14). This path routes a 5 V power source to an onboard interlock relay, which in turn enables power to the backplane relays. If a 37xA-ST screw-terminal accessory is used, a low-resistance path is provided to automatically engage the interlock circuit.

---

### **⚠ WARNING**

**The supplied 5 V power source is not designed for use with external circuits. Only use this power source to energize the interlock relay.**

**For reliable operation, be sure to provide a low-resistance path between the interlock pins. Significant resistance can cause the interlock circuit to fail to engage.**

---

## Check interlock status

You can check the status of the interlocks using the TSP command `slot[slot].interlock.state`, where `slot` is 1 to 6. When the interlock status is returned as engaged, you can energize the associated backplane relays. When interlock status is disengaged, you cannot energize the associated backplane relays.

Refer to the *Series 3700A System Switch/Multimeter Reference Manual* for more information on interlock commands. This manual is available at [tek.com/keithley](http://tek.com/keithley).

## Maximum power usage with 3700A cards

The 3700A plug-in cards can switch many relays at once, which can take a substantial amount of system power. The maximum power available in the 3700A is limited on a per-slot and per-bank basis, as shown in the following table.

Bank 1	Bank 2
Slot 1	Slot 4
Slot 2	Slot 5
Slot 3	Slot 6
12,300 mW (maximum)	12,300 mW (maximum)

The maximum slot power limit is 10,500 mW.

If the power levels are exceeded, the system performs as many of the operations as possible until the power limits are reached. When the power limits are reached, an error message is generated and the remaining operations are not performed.



## Power budgeting and calculation

Individual relay power consumption generally depends on the type of relay. Latching relays consume power briefly to open or close and are not a concern when budgeting power. Nonlatching relays continuously consume power to maintain their state, so they must be considered when budgeting for power consumption.

Each switch card also uses system power to operate. This continuous power draw is known as quiescent power. Quiescent power takes away power that is available to operate relays, so it must also be considered when budgeting for power consumption.

The following table shows the power consumption of channel and backplane relays for the 3700A switch cards. The quiescent power is also shown.

Model	Quiescent power (P <sub>Q</sub> )(milliwatts)	Channel relay power (P <sub>CR</sub> ) consumption each (milliwatts)	Backplane relay power (P <sub>BR</sub> ) consumption each (milliwatts)
3720	975	Not applicable	100
3721	1350	Not applicable	100
3722	475	Not applicable	100
3723	700	100 (2-pole)	100
		50 (1-pole)	100
3724	1150	20	100
3730	780	Not applicable	100
3731	780	67	100
3732	780	17	100
3740	1000	Not applicable (independent)	100
		200 (high current)	100

To determine how many relay operations can be performed, use the previous table to calculate the total power required by applying the following equation:

$$P_{TS} = P_Q + (N_{CC} \times P_{CR}) + (N_{BC} \times P_{BR})$$

Where:

- P<sub>TS</sub> is the total slot power
- P<sub>Q</sub> is the quiescent power
- N<sub>CC</sub> is the number of closed channels
- P<sub>CR</sub> is the power per channel relay
- N<sub>BC</sub> is the number of closed backplane channels
- P<sub>BR</sub> is the power per backplane relay

To calculate the total slot power, you must calculate the power for each bank of slots:

$$\text{Bank 1 Power} = \text{Slot 1 } P_{TS} + \text{Slot 2 } P_{TS} + \text{Slot 3 } P_{TS}$$

$$\text{Bank 2 Power} = \text{Slot 4 } P_{TS} + \text{Slot 5 } P_{TS} + \text{Slot 6 } P_{TS}$$

The results are called bank powers and should be compared with the maximum limits. Example calculations are shown in the following topics.

## Power budgeting example with six 3731 cards

This example is for a fully loaded 3706A-S with all 3731 switch cards.

Slot	Card	Channel relays closed	Backplane relays closed
1	3731	5	2
2	3731	5	2
3	3731	5	2
4	3731	5	2
5	3731	5	2
6	3731	5	2

This produces the power consumption shown in the following table.

	$P_0$		$N_{CC} \times P_{CR}$		$N_{BC} \times P_{BR}$		$P_{TS}$
Slot 1 power consumed =	780	+	$5 \times 67$	+	$2 \times 100$	=	1315
Slot 2 power consumed =	780	+	$5 \times 67$	+	$2 \times 100$	=	1315
Slot 3 power consumed =	780	+	$5 \times 67$	+	$2 \times 100$	=	1315
Slot 4 power consumed =	780	+	$5 \times 67$	+	$2 \times 100$	=	1315
Slot 5 power consumed =	780	+	$5 \times 67$	+	$2 \times 100$	=	1315
Slot 6 power consumed =	780	+	$5 \times 67$	+	$2 \times 100$	=	1315

Totals for each bank are calculated as shown in the following table.

	Slot 1		Slot 2		Slot 3		Total
Bank 1 power consumed =	1315	+	1315	+	1315	=	3945

	Slot 4		Slot 5		Slot 6		Total
Bank 2 power consumed =	1315	+	1315	+	1315	=	3945

Since each bank did not exceed the maximum power, the power budget is within the limits.

## Power budgeting example with multiple cards

This example is for a fully loaded 3706A-S with a mix of switch cards.

Slot	Card	Channel relays closed	Backplane relays closed
1	3720	20	2
2	3721	20	2
3	3722	15 (2-pole)	4
4	3724	30	2
5	3731	16	6
6	3732	2	4

This produces the following power consumption:

	$P_0$		$N_{CC} \times P_{CR}$		$N_{BC} \times P_{BR}$		$P_{TS}$
Slot 1 power consumed =	975	+	0	+	$2 \times 100$	=	1175
Slot 2 power consumed =	1350	+	0	+	$2 \times 100$	=	1550
Slot 3 power consumed =	475	+	0	+	$4 \times 100$	=	875
Slot 4 power consumed =	1150	+	$30 \times 20$	+	$2 \times 100$	=	1950
Slot 5 power consumed =	780	+	$16 \times 67$	+	$6 \times 100$	=	2452
Slot 6 power consumed =	780	+	$2 \times 17$	+	$4 \times 100$	=	1214

Totals for each bank are calculated:

	Slot 1		Slot 2		Slot 3		Total
Bank 1 power consumed =	1175	+	1550	+	875	=	3600

	Slot 4		Slot 5		Slot 6		Total
Bank 2 power consumed =	1950	+	2452	+	1214	=	5616

Since each bank did not exceed the maximum power, the power budget is within the limits.

## Model 3731 connection log

Use this table to record your 3731 connection information.

Connection		Color	Description
ROW 1	H		
	L		
ROW 2	H		
	L		
ROW 3	H		
	L		
ROW 4	H		
	L		
ROW 5	H		
	L		
ROW 6	H		
	L		
COLUMN 1	H		
	L		
COLUMN 2	H		
	L		
COLUMN 3	H		
	L		
COLUMN 4	H		
	L		
COLUMN 5	H		
	L		
COLUMN 6	H		
	L		
COLUMN 7	H		
	L		
COLUMN 8	H		
	L		
COLUMN 9	H		
	L		
COLUMN 10	H		
	L		
COLUMN 11	H		
	L		
COLUMN 12	H		
	L		
COLUMN 13	H		
	L		
COLUMN 14	H		
	L		
COLUMN 15	H		
	L		
COLUMN 16	H		
	L		

The following safety precautions should be observed before using this product and any associated instrumentation. Although some instruments and accessories would normally be used with nonhazardous voltages, there are situations where hazardous conditions may be present.

This product is intended for use by personnel who recognize shock hazards and are familiar with the safety precautions required to avoid possible injury. Read and follow all installation, operation, and maintenance information carefully before using the product. Refer to the user documentation for complete product specifications.

If the product is used in a manner not specified, the protection provided by the product warranty may be impaired.

The types of product users are:

**Responsible body** is the individual or group responsible for the use and maintenance of equipment, for ensuring that the equipment is operated within its specifications and operating limits, and for ensuring that operators are adequately trained.

**Operators** use the product for its intended function. They must be trained in electrical safety procedures and proper use of the instrument. They must be protected from electric shock and contact with hazardous live circuits.

**Maintenance personnel** perform routine procedures on the product to keep it operating properly, for example, setting the line voltage or replacing consumable materials. Maintenance procedures are described in the user documentation. The procedures explicitly state if the operator may perform them. Otherwise, they should be performed only by service personnel.

**Service personnel** are trained to work on live circuits, perform safe installations, and repair products. Only properly trained service personnel may perform installation and service procedures.

Keithley products are designed for use with electrical signals that are measurement, control, and data I/O connections, with low transient overvoltages, and must not be directly connected to mains voltage or to voltage sources with high transient overvoltages. Measurement Category II (as referenced in IEC 60664) connections require protection for high transient overvoltages often associated with local AC mains connections. Certain Keithley measuring instruments may be connected to mains. These instruments will be marked as category II or higher.

Unless explicitly allowed in the specifications, operating manual, and instrument labels, do not connect any instrument to mains.

Exercise extreme caution when a shock hazard is present. Lethal voltage may be present on cable connector jacks or test fixtures. The American National Standards Institute (ANSI) states that a shock hazard exists when voltage levels greater than 30 V RMS, 42.4 V peak, or 60 VDC are present. A good safety practice is to expect that hazardous voltage is present in any unknown circuit before measuring.

Operators of this product must be protected from electric shock at all times. The responsible body must ensure that operators are prevented access and/or insulated from every connection point. In some cases, connections must be exposed to potential human contact. Product operators in these circumstances must be trained to protect themselves from the risk of electric shock. If the circuit is capable of operating at or above 1000 V, no conductive part of the circuit may be exposed.

Do not connect switching cards directly to unlimited power circuits. They are intended to be used with impedance-limited sources. NEVER connect switching cards directly to AC mains. When connecting sources to switching cards, install protective devices to limit fault current and voltage to the card.

Before operating an instrument, ensure that the line cord is connected to a properly-grounded power receptacle. Inspect the connecting cables, test leads, and jumpers for possible wear, cracks, or breaks before each use.

When installing equipment where access to the main power cord is restricted, such as rack mounting, a separate main input power disconnect device must be provided in close proximity to the equipment and within easy reach of the operator.

For maximum safety, do not touch the product, test cables, or any other instruments while power is applied to the circuit under test. ALWAYS remove power from the entire test system and discharge any capacitors before connecting or disconnecting cables or jumpers, installing or removing switching cards, or making internal changes, such as installing or removing jumpers.

Do not touch any object that could provide a current path to the common side of the circuit under test or power line (earth) ground. Always make measurements with dry hands while standing on a dry, insulated surface capable of withstanding the voltage being measured.

For safety, instruments and accessories must be used in accordance with the operating instructions. If the instruments or accessories are used in a manner not specified in the operating instructions, the protection provided by the equipment may be impaired.

Do not exceed the maximum signal levels of the instruments and accessories. Maximum signal levels are defined in the specifications and operating information and shown on the instrument panels, test fixture panels, and switching cards.

When fuses are used in a product, replace with the same type and rating for continued protection against fire hazard.

Chassis connections must only be used as shield connections for measuring circuits, NOT as protective earth (safety ground) connections.

If you are using a test fixture, keep the lid closed while power is applied to the device under test. Safe operation requires the use of a lid interlock.

If a  screw is present, connect it to protective earth (safety ground) using the wire recommended in the user documentation.

The  symbol on an instrument means caution, risk of hazard. The user must refer to the operating instructions located in the user documentation in all cases where the symbol is marked on the instrument.

The  symbol on an instrument means warning, risk of electric shock. Use standard safety precautions to avoid personal contact with these voltages.

The  symbol on an instrument shows that the surface may be hot. Avoid personal contact to prevent burns.

The  symbol indicates a connection terminal to the equipment frame.

If this  symbol is on a product, it indicates that mercury is present in the display lamp. Please note that the lamp must be properly disposed of according to federal, state, and local laws.

The **WARNING** heading in the user documentation explains hazards that might result in personal injury or death. Always read the associated information very carefully before performing the indicated procedure.

The **CAUTION** heading in the user documentation explains hazards that could damage the instrument. Such damage may invalidate the warranty.

The **CAUTION** heading with the  symbol in the user documentation explains hazards that could result in moderate or minor injury or damage the instrument. Always read the associated information very carefully before performing the indicated procedure. Damage to the instrument may invalidate the warranty.

Instrumentation and accessories shall not be connected to humans.

Before performing any maintenance, disconnect the line cord and all test cables.

To maintain protection from electric shock and fire, replacement components in mains circuits — including the power transformer, test leads, and input jacks — must be purchased from Keithley. Standard fuses with applicable national safety approvals may be used if the rating and type are the same. The detachable mains power cord provided with the instrument may only be replaced with a similarly rated power cord. Other components that are not safety-related may be purchased from other suppliers as long as they are equivalent to the original component (note that selected parts should be purchased only through Keithley to maintain accuracy and functionality of the product). If you are unsure about the applicability of a replacement component, call a Keithley office for information.

Unless otherwise noted in product-specific literature, Keithley instruments are designed to operate indoors only, in the following environment: Altitude at or below 2,000 m (6,562 ft); temperature 0 °C to 50 °C (32 °F to 122 °F); and pollution degree 1 or 2.

To clean an instrument, use a cloth dampened with deionized water or mild, water-based cleaner. Clean the exterior of the instrument only. Do not apply cleaner directly to the instrument or allow liquids to enter or spill on the instrument. Products that consist of a circuit board with no case or chassis (e.g., a data acquisition board for installation into a computer) should never require cleaning if handled according to instructions. If the board becomes contaminated and operation is affected, the board should be returned to the factory for proper cleaning/servicing.

Safety precaution revision as of June 2018.