

INSTRUCTION MANUAL
MODEL 147
NANOVOLT NULL DETECTOR

KEITHLEY INSTRUMENTS



WARRANTY

We warrant each of our products to be free from defects in material and workmanship. Our obligation under this warranty is to repair or replace any instrument or part thereof which, within a year after shipment, proves defective upon examination. We will pay local domestic surface freight costs.

To exercise this warranty, write or call your local Keithley representative, or contact Keithley headquarters in Cleveland, Ohio. You will be given prompt assistance and shipping instructions.

REPAIRS AND CALIBRATION

Keithley Instruments maintains a complete repair and calibration service as well as a standards laboratory in Cleveland, Ohio. A service facility is also located in Los Angeles for our west coast customers.

A Keithley service facility at our Munich, Germany office is available for our customers throughout Europe. Service in the United Kingdom can be handled at our office in Reading. Additionally, Keithley representatives in most countries maintain service and calibration facilities.

To insure prompt repair or recalibration service, please contact your local field representative or Keithley headquarters directly before returning the instrument. Estimates for repairs, normal recalibrations and calibrations traceable to the National Bureau of Standards are available upon request.

KEITHLEY
The measurement engineers.

Keithley Instruments, Inc., 28775 Aurora Road, Cleveland, Ohio 44139. (216) 248-0400

European Headquarters: Heighofstrasse 5, D-8000 Munchen 70 West Germany, (0811) 7144065

United Kingdom: 1 Boulton Road, Reading, Berkshire, (0734) 881287

France: 44 Rue Anatole France, F-91121 Palaiseau (01) 928-00-48

INSTRUCTION MANUAL
MODEL 147
NANOVOLT NULL DETECTOR

©COPYRIGHT 1972, KEITHLEY INSTRUMENTS, INC.
PRINTED, APRIL 1977, CLEVELAND, OHIO, U. S. A.

CONTENTS

<u>Section</u>	<u>Page</u>
SPECIFICATIONS-----	ii
1. GENERAL DESCRIPTION-----	1
2. OPERATION-----	5
3. APPLICATIONS-----	21
4. CIRCUIT DESCRIPTION-----	25
5. MAINTENANCE-----	31
6. REPLACEABLE PARTS-----	51
SCHEMATICS-----	65

ILLUSTRATIONS

Figure No.	Title	Page
1a.	Front Panel.	1
1b.	Front Panel with Cable	3
2.	Front Panel Controls	4
3.	Model 147 Rear Panel Controls & Connections.	6
4.	Model 1481 Low-Thermal Input Cable	10
5.	Model 1483 Low-Thermal Connection Kit.	10
6.	Bus System for Model 147	12
7.	Thermal Sink Construction.	15
8.	Normal Wave Form at Demodulator with Input Shorted	17
9.	Wave Form at Demodulator Shown with Some Pickup.	17
10.	Wave Form at Demodulator when Amplifier is Saturated	17
11.	8-cps Filter Circuit for Recorder Output	18
12.	Using Model 147 with 4-Terminal Connections.	18
13.	Exploded View for Rack Mounting	19
14.	Circuit Using Guildline 9144 with Model 147 Null Detector	21
15.	Circuit Using Guildline 4363DL with Model 147 Null Detector.	22
16.	Circuit Using Guildline 9120 with Model 147 Null Detector.	22
17.	Circuit Using Biddle 605001 with Model 147 Null Detector	23
18.	Circuit Using Leeds & Northrup 7556.	23
19.	Circuit Using Model 147 Null Detector with ESI 240, 800R and RS 925.	24
20.	Block Diagram of Model 147 Amplifier Circuits.	25
21.	Model 147 Input Circuit.	26
22.	Diagram of Power Supplies & Battery Charging Circuit	29
23.	Model 147 Input Compartment.	32
24.	Correct Wave Form in dc-to-dc Inverter	36
25.	Correct Wave Form in Oscillator Circuit.	38
26.	Improper Wave Forms in Oscillator Circuit.	38
27.	Correct Wave Form at Demodulator Test Jack	41
28.	Out-of-Phase Wave Form at Demodulator Test Jack.	41
29.	Top View of Model 147 Chassis	44
30.	Bottom View of Model 147 Chassis	45
31.	Transistor Locations on Printed Circuit 76	46
32.	Capacitor & Diode Locations on Printed Circuit 76.	46
33.	Resistor Locations on Printed Circuit 76	47
34.	Resistor & Test Point Locations on Printed Circuit 76.	47
35.	Resistor & Test Point Locations on Printed Circuit 74, Bottom Face	48
36.	Component Locations on Printed Circuit 74, Top Face.	48
37.	Resistor & Test Point Location on Printed Circuit 75	49
38.	Capacitor & Transistor Locations on Printed Circuit 75	49
39.	Resistor Locations on RANGE Switch (S102).	50
40.	Resistor Locations on RANGE Switch (S102).	50

SPECIFICATIONS

RANGE: 30 nanovolts (30×10^{-9} volt) full scale to 100 millivolts on a zero-center meter. 16 overlapping ranges in 1x and 3x steps.

ACCURACY:

Meter: $\pm 2\%$ of full scale on all ranges.
 Output Terminals: $\pm 1\%$ of full scale on all ranges.
 Note: Accuracy specifications exclude noise and drift.

ZERO DRIFT: Less than 25 nanovolts per 24 hours after 1-hour warm-up with reasonably constant ambient temperature. Long term drift is non-cumulative.

INPUT NOISE (with input shorted): Less than 0.6 nanovolt rms (3 nanovolts peak-to-peak) on most sensitive range.

RESOLUTION:

With source resistances of 300 ohms or less:
 Better than $0.01 \mu\text{v}$ on $0.1\text{-}\mu\text{v}$ range.
 With source resistances of 10 ohms or less:
 Better than 3 nanovolts on most sensitive range.

ZERO SHIFT WITH SOURCE RESISTANCE:

Source resistances up to 500 ohms:
 Less than 5×10^{-11} volt per ohm.
 Source resistances of 500 to 100,000 ohms:
 Less than 10^{-10} volt per ohm.

(Shift measured with low thermal resistor after resistor and instrument have reached thermal equilibrium. Shift is exclusive of noise.)

INPUT CHARACTERISTICS:

Range	Input Resistance Greater than, ohms	Maximum Source ¹ Resistance, ohms	Line ² Frequency Rejection
30 nV	10 k	100	5000:1
0.1 μV	30 k	300	3000:1
0.3 μV	100 k	1000	1000:1
1.0 μV	300 k	3 k	500:1
3.0 μV	1 M	10 k	300:1
to			decreasing to
100 μV	10 M	100 k	50:1
0.03 mV			100:1
to			decreasing to
100 mV			5:1

Notes: 1 Source resistances higher than the recommended maximum will increase rise time and noise.
 2 Ratio of impressed peak-to-peak line frequency voltage at input to indicated dc voltage.

COMMON MODE REJECTION: 50 or 60 cps: greater than 180 db.
 100 or 120 cps: greater than 140 db. (See note 2 above.)

ISOLATION: Circuit ground to chassis ground: Greater than 10^{10} ohms shunted by 0.001 microfarad. Circuit ground may be floated up to ± 400 volts with respect to chassis ground. On battery operation, may be completely isolated from power line and ground.

RISE TIME (10% to 90%):

30-nanovolt Range: Less than 3 seconds when source resistance is less than 10% of maximum; 5 seconds using maximum source resistance.
0.1-microvolt to 100-millivolt Ranges: Less than 1 second when source resistance is less than 10% of maximum; 3 seconds using maximum source resistance.

ZERO SUPPRESSION: Up to 100 microvolts available. Stability such that 100 times full scale may be suppressed.

RECORDER OUTPUT:

Output: ± 1 volt dc at up to 1 milliampere for full-scale meter deflection on any range.
Resistance: Less than 5 ohms within the amplifier pass band.

Gain: $\frac{1 \text{ volt}}{\text{range setting in volts}}$

Noise: Input noise times gain plus modulation products.
Modulation Products: Less than 2% peak-to-peak of full scale with input shorted.

CONNECTORS: Input: Special Keithley Model 1485. Output: Amphenol 80-PC2F.

POWER:

Line Operation: 105-125 or 210-250 volts (switch selected), 60 cps, 16 watts. 50-cps models available.
Battery Operation: Rechargeable nickel-cadmium 6-volt battery pack. 14 hours full charge to complete discharge. For maximum battery life, battery operation recommended for no more than 8 consecutive hours before recharge.

DIMENSIONS, WEIGHT: Supplied as bench unit. $5\frac{1}{2}$ " high x $17\frac{1}{2}$ " wide x 10" deep; net weight, 20 pounds.

ACCESSORIES SUPPLIED: Model 1481 Low-Thermal Input Cable with alligator clips; mating output and demodulator test plugs; internally mounted nickel-cadmium battery pack and charging circuit.

SECTION 1. GENERAL DESCRIPTION

1-1. GENERAL.

a. The Keithley Model 147 is designed specifically as a convenient self-contained dc electronic null detector. Its sensitivity is 0.6×10^{-3} microvolt per millimeter or 0.03×10^{-6} microampere per millimeter. Its resolution is better than 3 nanovolts with a 10-ohm source resistance and 10 nanovolts with a 300-ohm source resistance. This corresponds to a power sensitivity of 3×10^{-21} watt. Zero shift is less than 15 nanovolts for source resistance changes from 0 to 300 ohms. Line frequency rejection is better than 5000:1 on its most sensitive range.

b. The Model 147 has 16 ranges from 30 nanovolts full scale to 100 millivolts on a zero-center meter. Meter accuracy is $\pm 2\%$ of full scale on all ranges.

c. For reliable and versatile use, the Null Detector is of solid-state design, except for the first two input stages. It has high line isolation — 10^{10} ohms — and battery or ac power line operation.

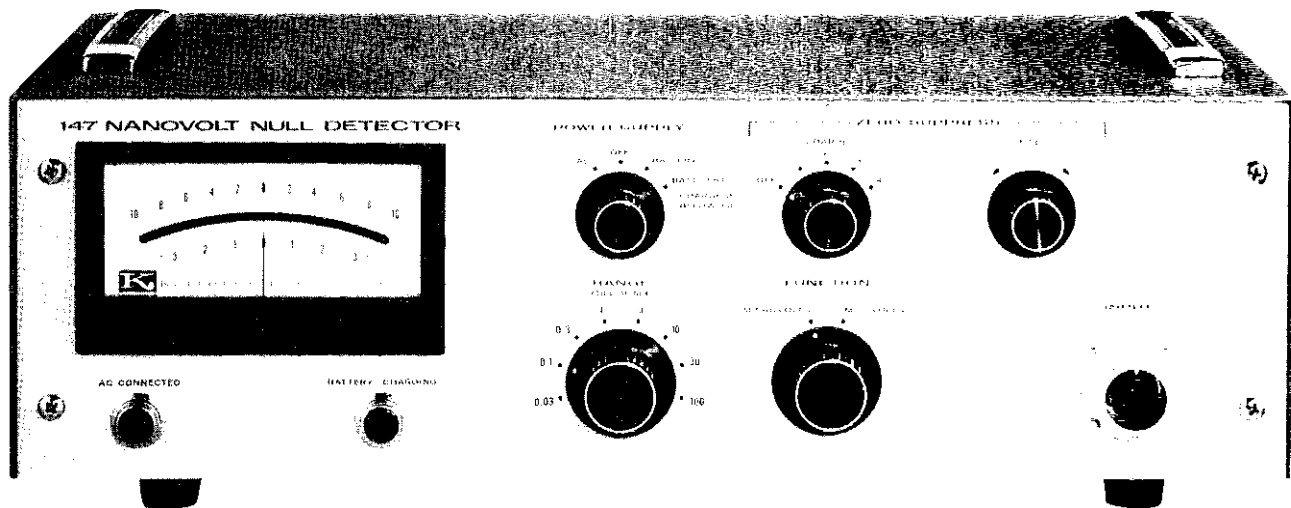

FIGURE 1a. Front panel.

1-2. FEATURES.

a. Battery operation permits complete isolation from ac power lines, eliminating many grounding problems. Battery operation also allows flexibility and convenience in use. The Model 147 automatically recharges the battery if needed when the power cord is connected.

b. As an electronic null detector, the Model 147 is immune to mechanical vibrations. It will also recover from a 2-volt overload on its most sensitive range in less than 20 seconds.

c. Besides performing as a null detector, the Model 147 can also be used as a 2% direct-reading nanovoltmeter.

d. The Null Detector has an output of ± 1 volt at up to 1 milliampere for full-scale meter deflections to drive a recorder or oscilloscope. Output accuracy is $\pm 1\%$ of full scale.

e. A zero suppression circuit, furnishing up to 100 microvolts, permits measuring small changes in a larger dc signal or compensating for thermal emf's.

1-3. APPLICATIONS. (Also see Section 3.)

a. The Model 147 is designed specifically as a null detector. It has sufficient sensitivity to be used in most applications with all commercially available potentiometers, including 6-dial models, ratio sets and resistance bridges, including Wenner, Wheatstone and Kelvin Double Bridges. It can be used to make 4-terminal measurements.

b. Keithley's Model 147 is more sensitive than the finest galvanometer systems. It is also immune to mechanical vibrations, thus eliminating the need for shock-free mountings. Additional advantages over galvanometer systems include the ability to recover from 2-volt overloads in 20 seconds, much less off-null loading, plus considerably faster speed of response.



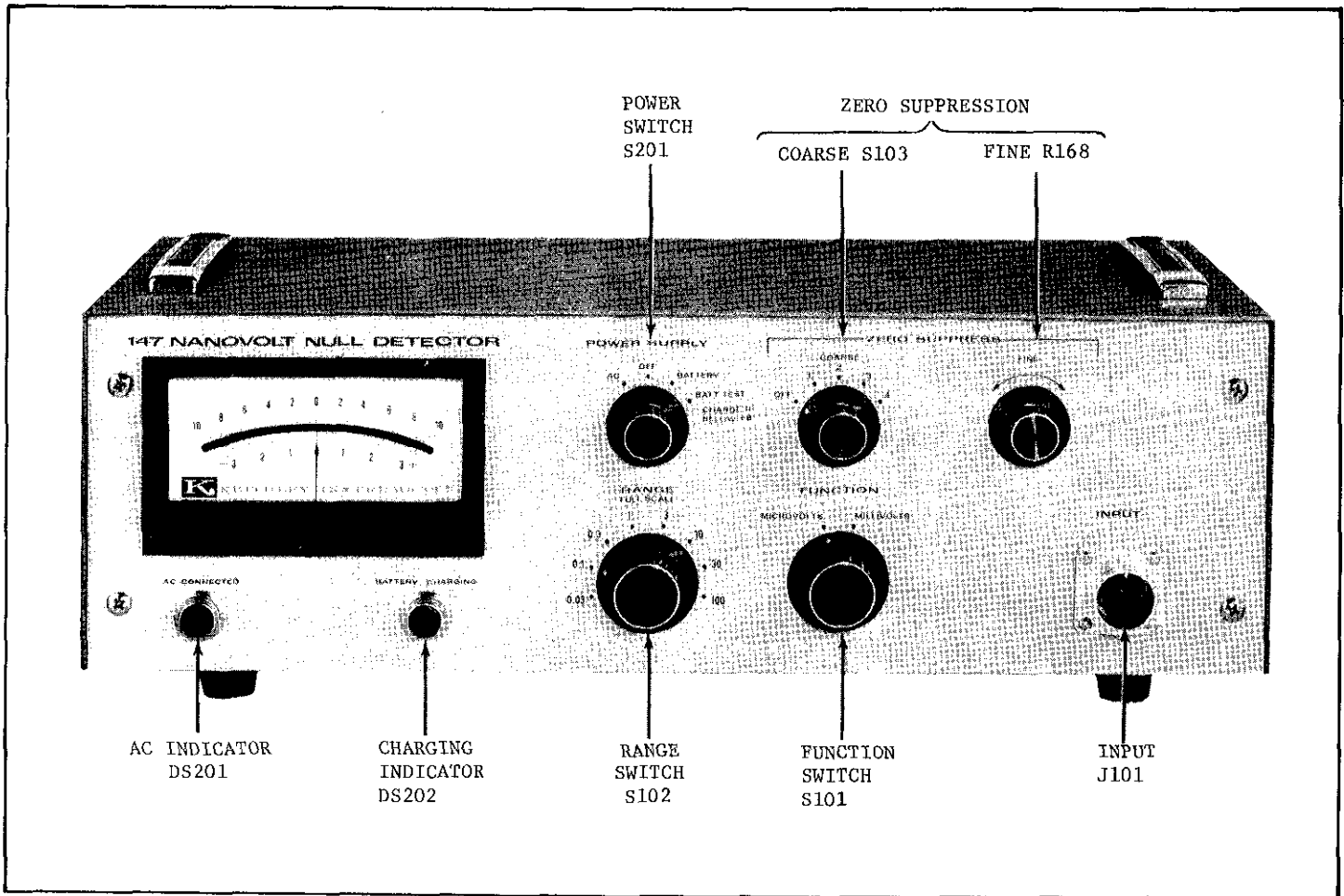

FIGURE 2. Front Panel Controls.

SECTION 2. OPERATION

2-1. FRONT PANEL CONTROLS. (See Figure 2.)

a. AC CONNECTED Lamp. The Lamp is lit whenever the unit is connected to the ac power line and the POWER SUPPLY Switch is in the AC or OFF position.

NOTE

The AC CONNECTED Lamp indicates only that the instrument is connected to the ac power line; it does not indicate that the Null Detector is operating. Also, when the POWER SUPPLY Switch is turned from AC to OFF, a difference in Lamp brightness is normal.

b. BATTERY CHARGING Lamp. When lit, this Lamp indicates the battery is charging. The charge current determines its brightness. If the Lamp is not lit, then the battery is charged.

c. POWER SUPPLY Switch. The Switch controls the mode of operation for the power supply.

1. AC position: The Null Detector will operate from the ac power line. The battery will be charged if needed; then, the BATTERY CHARGING Lamp will light.

2. OFF position: The Model 147 is not operating. However, the battery will be charged, if needed and if the power cord is connected.

3. BATTERY position: The Null Detector is operating from its battery. The ac power line is internally disconnected, whether or not the power cord is connected; the AC CONNECTED Lamp is off; the battery cannot be charged.

4. BATT. TEST position: When the POWER SUPPLY Switch is held in this position, the Model 147 shows the state of the battery charge directly on its meter. All circuits within the instrument are the same as for battery operation except at the meter terminals.

POWER SUPPLY Switch Setting	Power Cord Connected	AC CONNECTED Lamp	BATTERY CHARGING Lamp (If battery is charging)
AC	Yes	On	On
OFF	Yes	On	On
	No	Off	Battery cannot be charged
BATTERY	Yes	Off	Battery cannot be charged
	No	Off	Battery cannot be charged
BATT TEST	Yes	Off	Battery cannot be charged
	No	Off	Battery cannot be charged

TABLE I. Indicating Lamps and POWER SUPPLY Switch Settings. The Table shows the relationship between the front panel lamps, the power cord and the POWER SUPPLY Switch setting.

- d. RANGE Switch. The RANGE Switch selects the full-scale meter sensitivity (either microvolts or millivolts) for one of eight ranges, from 0.03 to 100.
- e. FUNCTION Switch. The FUNCTION Switch selects the function — MICROVOLTS or MILLI-VOLTS — which is to be measured.
- f. ZERO SUPPRESS Controls. Two controls determine the amount of zero suppression.
1. The COARSE Control disconnects the suppression circuit (in OFF position) or selects one of four suppression voltages in decade steps. Refer to Table 3.
 2. The FINE Control is a continuously variable adjustment for the suppression voltage set by the COARSE Control. It adjusts the range between the positive and negative values of the maximum voltage set by the COARSE Control.
- g. INPUT Receptacle. The INPUT Receptacle is of a special low-thermal design. Use only the Models 1481, 1482, 1486 and 1488 for mating connectors.

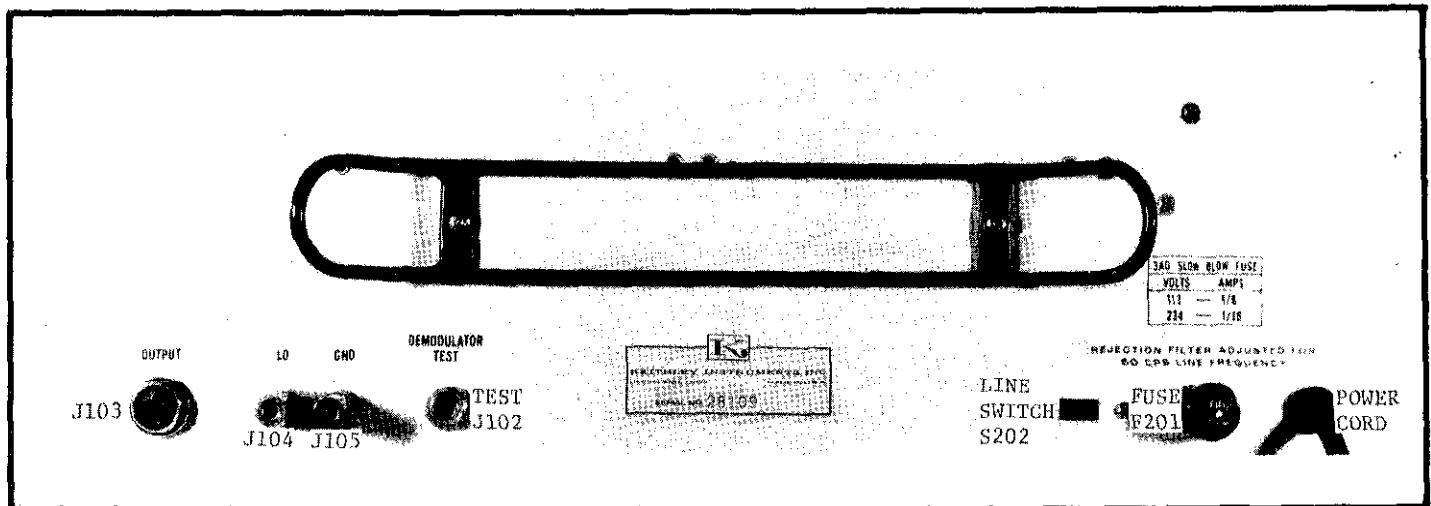

FIGURE 3. Model 147 Rear Panel Controls and Connections. Circuit designations refer to Replaceable Parts List and schematic diagrams.

2-2. REAR PANEL CONTROLS AND CONNECTIONS.

- a. Line Voltage Switch. The screwdriver-operated slide switch sets the Model 147 for 117 or 234-volt ac power lines.
- b. Fuse.
 1. For 117-volt operation, use a 3 AG or MDL Slow-Blow 1/8-ampere fuse.
 2. For 234-volt operation, use only a MDL Slow-Blow 1/16-ampere fuse.
- c. Power Cord. The 3-wire power cord with the NEMA approved 3-prong plug provides a ground connection for the cabinet. An adapter for operation from 2-terminal outlets is provided.

NOTE

A note above the power cord shows the ac power line frequency for which the rejection filter is adjusted. The instrument will work at any line frequency from 50 to 1000 cps, but ac rejection is best at the indicated frequency. Paragraph 2-18 describes adjusting the filter circuit.

d. DEMODULATOR TEST Jack. A phone jack provides access to the demodulator for test purposes.

e. OUTPUT. The OUTPUT Receptacle provides 11 volt at one milliampere for a full-scale meter deflection on any range.

f. GND and LO Terminals. The ground terminal (GND) is connected to the chassis and the third wire of the power cord. The low terminal is connected to circuit ground and the low side of the input connection.

2-3. MODE OF OPERATION. The Model 147 operates either from an ac power line or from its battery. For most uses, it functions well from ac. Use battery operation, however, if the ac power line will create ground loop or isolation problems. Isolation from low to ground is complete for battery operation when the power cord is disconnected; it is greater than 10^{10} ohms with the power cord connected. Also use battery operation to reduce the 8-cps ripple which may appear at the output with the input shorted in ac operation. See paragraph 2-16.

NOTE

Before using the battery operation, thoroughly read paragraph 2-4. Improper battery operation can damage the battery pack and lead to inaccurate measurements.

2-4. BATTERY OPERATION.

a. The Model 147 is supplied with a rechargeable 6-volt, 4 ampere-hour nickel-cadmium battery pack (Model 1489). Recommended: Do not use the battery more than eight consecutive hours without recharging. At this discharge rate, the battery should last about 1000 recharge cycles.

NOTE

Permanent damage to the battery pack occurs if it is used for more than 16 consecutive hours without recharging. At this discharge rate, the recharge cycles are greatly reduced. Before using the Model 147, check the state of the battery charge.

b. Check the battery charge before making a measurement. Hold the POWER SUPPLY Switch in the BATT. TEST position. The minimum acceptable charge is a meter indication of .8; full charge is shown by the BATTERY CHARGING Lamp not being lit. Recharge if needed. Otherwise, battery operation is the same as for the ac power line operating mode; refer to paragraph 2-5.

NOTE

When the battery is used beyond its capacity, two effects are seen. There is a shift in zero offset from ac to battery operation. Also, the power supplies do not regulate and high ripple voltages appear at the supply outputs. (See paragraph 5-8.)

c. To recharge the battery, connect the power cord to an ac power line. Turn the POWER SUPPLY Switch to AC or OFF. The BATTERY CHARGING Lamp will light. The battery will be charged only if needed, and the circuit automatically prevents it from being overcharged.

d. It is suggested that the battery be used during the day and be recharged at night. Leave the instrument always connected to the ac power line; then turn the POWER SUPPLY Switch to OFF at night. After a fully charged battery is used for eight consecutive hours, it will recharge within 16 hours. Leaving the power cord connected has little effect on the isolation: 10^{10} ohms with the POWER SUPPLY Switch in BATTERY position and the shorting link between GND and LO Terminals disconnected.

2-5. OPERATING PROCEDURES.

a. Set the front panel controls as follows:

POWER SUPPLY Switch	OFF
FUNCTION Switch	MILLIVOLTS
RANGE Switch	100
ZERO SUPPRESS COARSE Control	OFF

NOTE

Make sure the ZERO SUPPRESS COARSE Control is OFF. If it is not, a suppression voltage is introduced, causing an error in measurements.

b. Connect the voltage source or null circuit to the INPUT Receptacle. Refer to paragraph 2-6 for suggestions.

c. Check the voltage shown on the rear panel Line Voltage Switch; connect the Model 147 to the ac power line. Make sure the frequency shown above the power cord is the frequency of the ac power line. At this point, the AC CONNECTED Lamp will light, as will the BATTERY CHARGING Lamp if the battery is being charged. If the circuit low is to be at ground, put the shorting link between the LO and GND posts on the rear panel.

d. Turn the POWER SUPPLY Switch to the desired mode of operation, AC or BATTERY.

e. Increase the Model 147 sensitivity until the meter shows the greatest on-scale deflection.

1. Check the source resistance to make sure it is within the maximum value specified for the range being used. (See Table 2.) If the maximum resistance for the more sensitive ranges is exceeded, the Model 147 may not measure within its specifications.

2. Zero offsets seen when the Zero Suppress Controls are off will vary with the quality of the circuit's thermal construction. See paragraph 2-14. When a Model 1488 Shorting Plug is connected to the Model 147 INPUT Receptacle, offset should be less than 0.3 microvolt.

Range	Input Resistance Greater Than	Maximum Source Resistance	Minimum Line Frequency Rejection
0.03 microvolt	10 k Ω	100 Ω	5000:1
0.1 microvolt	30 k Ω	300 Ω	3000:1
0.3 microvolt	100 k Ω	1000 Ω	1000:1
1 microvolt	300 k Ω	3 k Ω	1000:1
3 microvolts	1 M Ω	10 k Ω	100:1
10 microvolts	1 M Ω	10 k Ω	100:1
30 microvolts	1 M Ω	10 k Ω	100:1
100 microvolts	1 M Ω	10 k Ω	100:1
0.03 millivolt	10 M Ω	100 k Ω	50:1
0.1 millivolt	10 M Ω	100 k Ω	20:1
0.3 millivolt	10 M Ω	100 k Ω	20:1
1 millivolt	10 M Ω	100 k Ω	20:1
3 millivolts	10 M Ω	100 k Ω	10:1
10 millivolts	10 M Ω	100 k Ω	10:1
30 millivolts	10 M Ω	100 k Ω	5:1
100 millivolts	10 M Ω	100 k Ω	5:1

TABLE 2. Model 147 Input Resistance, Maximum Source Resistance, and Minimum Line Frequency Rejection by Range. The rejection is the ratio of impressed peak-to-peak line frequency (50 or 60 cps) voltage at input to the indicated dc voltage.

3. Shifts in source resistance affect the zero shift very little. The zero shift is usually less than that caused by thermal emf's in the resistors in potentiometric and bridge circuits. (For adjustments, see paragraph 5-11.)
4. If the input is left completely open-circuit, the meter will drift off scale on any range.
5. Refer to Table 4 if problems occur during the measurement.
- f. Two millivolt and microvolt ranges overlap: 0.03 and 0.1 millivolt and 30 and 100 microvolts. Use the millivolt ranges when the source resistance is high or if large 60-cps fields are present. The microvolt ranges are more convenient to use if subsequent measurements require more sensitive ranges. Refer to Table 2 for maximum source resistance and line frequency rejection by range.
- g. At low levels, spurious emf's may be generated simply by contact between the input leads and the circuit under test. If possible, always leave the instrument connected, and adjust the zero after establishing a zero reference in the apparatus under test.
- h. For connections to particular circuits, refer to Section 3. Also, the booklet, The Use of Keithley Null Detectors with High Resolution Potentiometers and Bridges, contains helpful information. It is available from Keithley Instruments, Inc., or your nearest representative.
- i. Later paragraphs (paragraph 2-11 and following) contain specific information to increase measurement accuracy. In general, the following principles must be considered to realize the full capability of the Model 147.

1. Make sure the signal is greater than Johnson noise in the source resistance (paragraph 2-12).
2. Use materials which generate a low thermal emf (paragraph 2-14).
3. Minimize temperature changes and thermal gradients (paragraph 2-14).
4. Reduce magnetically induced signals by proper shielding and minimizing experimental layout area (paragraph 2-15).
5. Eliminate ground loops through proper grounding and connection to the signal circuit (paragraph 2-16).

2-6. LOW-THERMAL INPUT CONNECTIONS.

a. The easiest connection to the Model 147 input is with the Model 1481 Low-Thermal Input Cable, supplied with the instrument. Use the Cable for temporary setups, for measurements at several points, and when fast connections are needed. The Model 1481 connects directly to the INPUT Receptacle.

b. Where more permanent setups are possible or where very low thermal connections are needed, use the Model 1482 Low-Thermal Input Cable. It is similar to the Model 1481, except it has bare copper leads instead of alligator clips. Clean the bare wire with a non-metallic abrasive, such as Scotch Brite, before making the connection. Making crimp connections, as possible with the Model 1483 Kit, is best.

c. If cadmium solder (Model 1503) is used for a connection, make sure the soldering iron used is clean and that it has not been used with regular solder before. Use only rosin solder flux. If possible, heat sink all cadmium-soldered joints together to reduce generated thermal emf's. Careful techniques will keep thermal emf's below 0.1 microvolt.

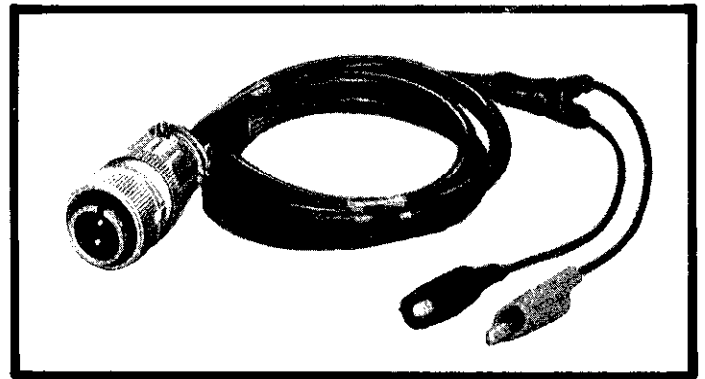

FIGURE 4. Model 1481 Low-Thermal Input Cable. The Model 1482 Low-Thermal Input Cable is similar except it has bare copper leads instead of alligator clips.

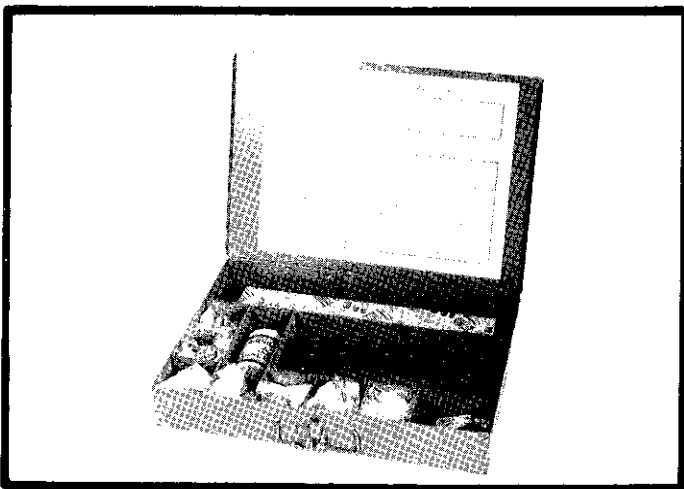

FIGURE 5. Model 1483 Low-Thermal Connection Kit. Refer to Section 6 for contents.

d. Use crimp connections with copper wire and lugs for the best low-thermal joints. Thermal emf's can be reduced to 10 nanovolts or less using the copper wire, sleeves and lugs found in the Model 1483 Low-Thermal Connection Kit. The Kit contains a crimp tool, shielded cable, an assortment of copper lugs, copper wire, cadmium solder and nylon bolts and nuts. It is a complete kit for making very low thermal measuring circuits. The Kit enables the user of the Model 147 to maintain the

high thermal stability of the Null Detector in his own circuit. Section 5 lists the contents of the Kit.

e. The Model 1486 Male Low-Thermal Input Connector is for connecting custom-made circuits to the Model 147.

f. The Model 1488 consists of a low thermal short, insulated from its housing. The housing provides a large thermal mass to greatly reduce the effects of ambient temperature fluctuations.

g. Other input accessories are: The Model 1484 Refill Kit, which contains replacement parts for the Model 1483. The Model 1485 female low-thermal input connector to use with the Model 1481, 1482 or 1486 for building shielded low-thermal circuits.

2-7. ZERO SUPPRESS OPERATION.

a. Purpose: The zero suppression circuit cancels any constant voltage in order to use a more sensitive range to observe a superimposed signal, such as thermal emf's. Up to 100 times full scale may be suppressed on the ranges from 1 to 0.03 microvolt. For example, the Model 147 can measure changes of less than 1 microvolt in a 100-microvolt steady signal on its 1-microvolt range.

b. Suppression Voltages Available: The COARSE Control sets the suppression voltage to one of four values. (Refer to Table 3.) The FINE Control continuously adjusts the voltage between the positive and negative value of the COARSE Control setting. For example, if the COARSE Control is at 2 for a suppression voltage of 1.2 microvolts, the FINE Control adjustment span is from $-1.2 \mu\text{v}$ to 0 to $+1.2 \mu\text{v}$.

ZERO SUPPRESS COARSE Control Setting	Maximum Suppression Voltage
1	0.36 microvolt
2	1.2 microvolts
3	12 microvolts
4	120 microvolts

TABLE 3. Suppression Voltage by Control Settings. The zero suppression voltage shown is the maximum value, $\pm 15\%$.

c. Operation.

1. Keep the COARSE Control in OFF position. Adjust the RANGE and FUNCTION Switches for the most sensitive meter reading.
2. Completely turn the FINE Control in the direction opposite to the meter deflection (counterclockwise for positive deflections and clockwise for negative deflections).
3. Increase the COARSE Control setting until the meter needle passes through zero. Adjust the FINE Control for zero deflection.
4. Set the RANGE Switch to a more sensitive range, up to 100 times more sensitive than the original range if it was 100 microvolts or less. Re-adjust the FINE Control to zero, if necessary.

d. The zero suppress adjustments can lead to some confusion, since zero may be adjusted to any value. The null point of the null detector is that point at which there is no meter deflection when polarity is reversed. This null point may be set to any value on the meter by the zero suppress circuit of the instrument. Determine the null point using the high sensitivity and reversal keys and then set the Model 147 to its maximum sensitivity.

2-8. FLOATING OPERATION.

a. The Model 147 can be connected between two potentials, neither of which is at power line ground. It can be floated up to ± 400 volts off ground.

CAUTION

The front panel controls are electrically connected to the case. If the power cord is unplugged, the case may be at a voltage equal to the off-ground voltage. Use necessary safety precautions.

b. For best results with floating operation, follow the steps below:

1. Remove the shorting link from the LO or GND Post on the rear panel.
2. Connect the input circuit to the Null Detector. Operate as described in paragraph 2-5. The zero suppress controls may also be used. Do not ground any recorders used with this operation, since the low of the Model 147 output is no longer grounded.
3. If power line frequency pickup is a problem, battery operation usually provides better results.

2-9. RECORDER OUTPUT. The Null Detector output for a full-scale meter deflection on any range is ± 1 volt at 1 milliampere. Accuracy is $\pm 1\%$ of full scale. Output resistance is less than 5 ohms within the amplifier pass band. Output may be used during both ac and battery operation. If the Model 147 is used for differential measurements, do not ground the recorder connected to the output.

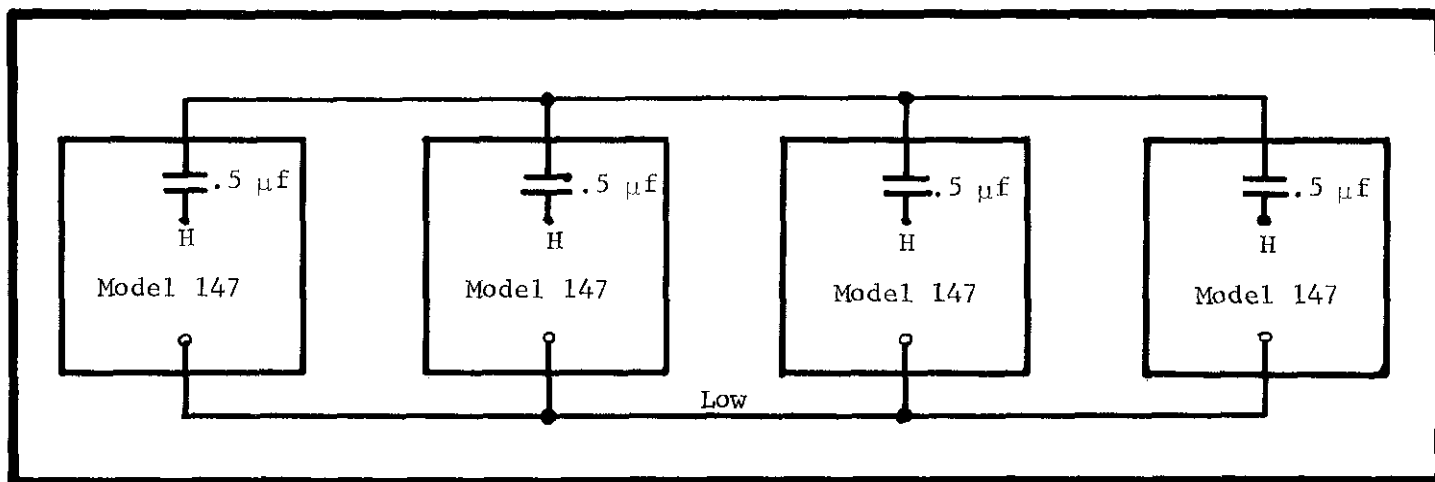

FIGURE 6. Synchronized Buss System for Model 147. When two or more Null Detectors are used in one system, an oscillator beat may occur; see paragraph 2-10. Synchronize the instruments by connecting them as shown. See Figure 29 for point H.

2-10. USING MORE THAN ONE MODEL 147 IN A SYSTEM.

a. The Model 147 oscillator is adjusted for a nominal frequency of 94 cps. However, slight variations in frequency do occur between models. When using two or more Null Detectors in one system, an oscillator beat may occur.

b. Synchronizing oscillators prevents an objectionable beat. Connect the two instruments together at the collector of transistor Q19 (Figure 29, point H), using an 0.5-microfarad mylar capacitor.

c. At times the system is such that the Null Detector lows may not be connected directly together. Then, use a 1:1 transformer having a fairly high impedance between the two instruments. A 110-volt, low power isolation transformer works well. Use a 0.5-microfarad isolation capacitor in series with both primary and secondary windings of the transformer.

d. For several Null Detectors connected together, use a synchronized buss system as shown in Figure 6.

2-11. ACCURACY CONSIDERATIONS. For sensitive measurements — 10 millivolts and below — other considerations beside the instrument affect accuracy. Effects not noticeable when working with higher voltages are very important with microvolt signals. The Model 147 reads only the signal received at its input; therefore, it is important that this signal be properly transmitted from the source. The following paragraphs indicate factors which affect accuracy: thermal noise, input resistance, thermal emf's, shielding and circuit connections. Table 4 also offers a quick reference to correct troubles which may occur.

2-12. THERMAL NOISE.

a. The lower limit in measuring small potentials occurs when the Johnson noise, or thermal agitation, becomes evident. The amount of noise present in the source is shown in the following equations.

1. The thermal noise in any ideal resistance can be determined from the Johnson noise equation:

$$E_{\text{rms}}^2 = 4 k T R F \quad \text{Eq. 1}$$

where E_{rms} is the rms noise voltage developed across the voltage source;

T is the temperature in degrees Kelvin;

R is the source resistance in ohms;

F is the amplifier bandwidth in cps;

k is the Boltzmann constant (1.38×10^{-23} joules / °K).

For an ideal resistance at room temperature (300°K), equation 1 simplifies to

$$E_{\text{rms}} = 1.29 \times 10^{-10} (RF)^{1/2} \quad \text{Eq. 2}$$

2. Peak-to-peak meter indications are of more interest than the rms value. Experimentally, the peak-to-peak Johnson noise is about five times the rms value. At room temperature, equation 2 becomes

$$E_{\text{pp}} = 6.45 \times 10^{-10} (RF)^{1/2} \quad \text{Eq. 3}$$

where E_{pp} is the peak-to-peak noise voltage developed across the voltage source.

Trouble (seen on Meter)	Possible Cause	Refer to
Change in offset between ac and battery operation	Low battery	paragraph 2-4
Very slow response time	High source resistance	paragraph 2-13
	Improper shielding	paragraph 2-16
Excessive drift	Thermal emf's	paragraph 2-14
	Improper connection to input	paragraph 2-17
Excessive noise or needle instability	High source resistance	paragraphs 2-12 and 2-13
	Improper shielding	paragraph 2-16
	Improper connection to input	paragraph 2-17
	Thermal emf's	paragraph 2-14
Excessive temperature sensitivity	Thermal emf's	paragraph 2-14
Presence of large, constant signal	Zero Suppress Controls On	paragraph 2-5
	Thermal emf's	paragraph 2-14
	Improper connection to input	paragraph 2-17
Excessive 8-cps beat at output or meter	Improper location or poor shielding	paragraph 2-16

TABLE 4. Troubleshooting Operating Procedures. The Table gives some possible sources of errors which occur while using the Model 147. It also refers to instructions to correct the situation.

3. The Model 147 bandwidth, F , can be estimated from the rise time, t_r , by:

$$F = 0.35/t_r \quad \text{Eq. 4}$$

The rise time varies with the range used and the source resistance. On the 0.1-microvolt range when the source resistance is less than 10 ohms, for example, the bandwidth is greater than 0.7 cps. The longest specified rise time for this situation is 0.5 second, so the 0.7-cps bandwidth is a minimum value.

4. As an example, determine the Johnson noise of a 10-ohm ideal resistor. Measured with the Model 147 on the 0.1-microvolt range and using equation 3, this becomes 17.1×10^{-10} volts peak-to-peak or 1.71 nanovolts peak-to-peak minimum.

b. In general, good wirewound or low-noise metal-film resistors approximate ideal resistors, and equations 2 and 3 are nearly correct. If the source resistance is composed of other materials, it may be necessary to include other terms in the equations to account for flicker, $1/f$, and current noise over and above the thermal noise.

c. As seen in equations 2 and 3, the noise of even low resistance values becomes significant in the microvolt region. The noise in non-ideal resistors is even greater. Therefore, keep the source resistance as low as possible. Other effects of high source resistance are decreased response speed and added pickup of extraneous voltages.

2-13. **INPUT RESISTANCE.** The Model 147 is a feedback amplifier; its input resistance is obtained using high feedback factors. When the source resistance exceeds the amplifier's physical input resistance — amplifier input resistance without feedback — the feedback is partially destroyed. Then the instrument may not operate properly. Normally, do not exceed the maximum source resistance listed in Table 2. Higher resistances can be used, but noise, offsets, slow response and instability may result. On the most sensitive ranges, the maximum specified source resistance is consistent with Johnson noise considerations.

2-14. **THERMAL EMF'S.**

a. Thermal emf's (thermo-electric potentials) are generated by thermal gradients between any two junctions of dissimilar metals. These can be large compared to the signals which the Model 147 can measure

b. Thermal emf's can cause the following problems:

1. Meter instability or zero offset much higher than expected. Note, though, the Model 147 can have some offset (paragraph 2-5).

2. Meter is very sensitive to ambient temperature differences. This is seen by touching the circuit, by putting a heat source near the circuit, or by a regular pattern of instability, corresponding to heating and air conditioning systems or changes in sunlight.

c. To minimize the drift caused by thermal emf's, use the same metal or metals having the same thermo-electric powers in the input circuit. Gold, silver and low-thermal solder have a thermo-electric power within about $\pm 0.25 \mu\text{v}/^\circ\text{C}$ of copper. This means a temperature imbalance of 1°C between these metals would generate a thermal emf of about 0.25 microvolt. At the other extreme, germanium has a thermoelectric power of about $320 \mu\text{v}/^\circ\text{C}$, and silicon will develop about $420 \mu\text{v}/^\circ\text{C}$ against copper. Standard physical handbooks contain tables of thermoelectric powers of materials. Since the Model 147 input circuit is made of pure copper, the best junction is copper to copper. However, copper oxide in the junction will cause thermal emf's on the order of 100 nanovolts per $^\circ\text{C}$ or less. Also, differences in processing of two pieces of copper can cause thermal emf's of up to 0.2 microvolt per $^\circ\text{C}$. The Model 1483 Kit contains all necessary equipment to make very low thermal copper crimp joints. See paragraph 2-6.

d. Besides using similar metals, thermal emf's can be reduced by maintaining constant temperatures. Keep all circuits from open windows, fans, air conditioning vents and similar sources which vary temperature. Minimize thermal gradients by placing all junctions physically close on a large heat sink. Thoroughly clean all copper leads before making a connection. Crimp together

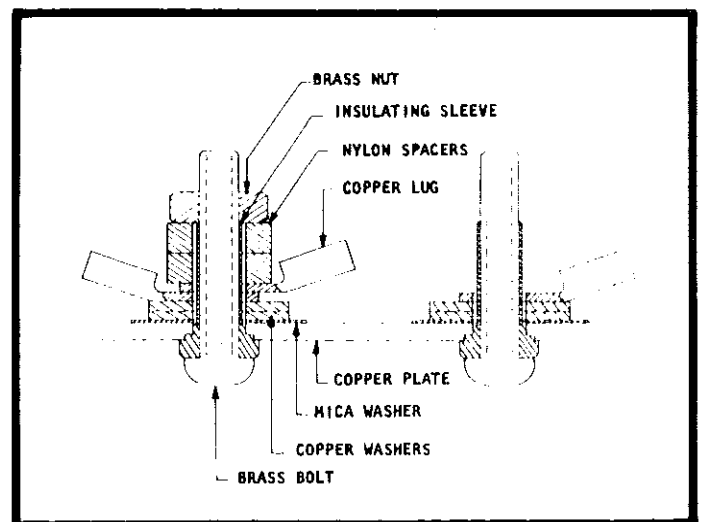

FIGURE 7. Thermal Sink Construction. Connect leads or lugs as close as possible. Separate only with insulation of high heat conductivity.

the ends of each copper wire; bolt the lugs for each connection point together; mount all stacks of lugs on a thick metal plate having high thermal conductivity. Thermal conductivity between the junctions and the heat sink can be kept at a high level by using mica washers or high conductivity ceramics for electrical insulation.

e. Several other techniques will reduce the effects of thermal emf's. Use the zero suppression circuit to buckout constant voltages. If connections must be soldered, use only cadmium-tin low-thermal solder, such as supplied in the Model 1483 Kit. Unlike metals — including regular solder — may be used and low thermal emf's obtained if a well-controlled oil bath or a good heat sink is used. Thermal voltages may be calculated from the thermoelectric power of the materials in the junction and the possible temperature difference between the junctions.

2-15. MAGNETIC SHIELDING.

a. In the low resistance circuitry used with the Model 147, magnetic lines cutting a conductor can produce large signals compared to the instrument's sensitivity. The amount of signal developed is proportional to the area enclosed by the circuit and the rate of change of magnetic flux. For example, motion of a 3-inch diameter loop in the earth's magnetic field will induce a signal of several tenths of a microvolt. Increasing the size of the loop or moving it more rapidly will increase the signal. Magnetic fields from ac power lines will cause even more difficulty.

b. To reduce the effect of magnetic fields, use magnetic shielding. Where high ac magnetic fields are present, it may be necessary to magnetically shield the measuring circuit, the unknown emf circuit or auxiliary equipment in the circuit. Magnetic shielding is available from several companies in the form of plates, foil or cable.

c. Twist input leads to minimize the area enclosed by the circuit loop. Planning the experimental layout for minimum enclosed area is also of particular value.

2-16. AC SHIELDING.

a. Due to its narrow bandwidth, the Model 147 is somewhat insensitive to ac voltages superimposed upon a dc signal at the input terminals. However, ac voltages which are large compared with the dc signal may drive the Model 147 ac amplifier into saturation, erroneously producing a dc output at the demodulator. Usually it is sufficient to connect the cases of all apparatus in the measurement circuit together and ground at one point. This provides a "tree" configuration, which minimizes ground loops. The common point at which all shields are connected should be as near as possible to the circuit ground of the Null Detector at its input.

b. Improper shielding can cause the Model 147 to react in one or more of the following ways:

1. Needle jitter or instability, from 10% to 20% of full scale.
2. High offset (dc bias). Changing the power cord polarity or the connection between the LO and GND Posts may affect the amount of offset.
3. Slow response time, sluggish action and/or inconsistent readings between ranges.
4. Amplifier saturation. Observe the wave form with an oscilloscope connected to the DEMODULATOR TEST Jack (Figure 3). With the input shorted, it should approximate the

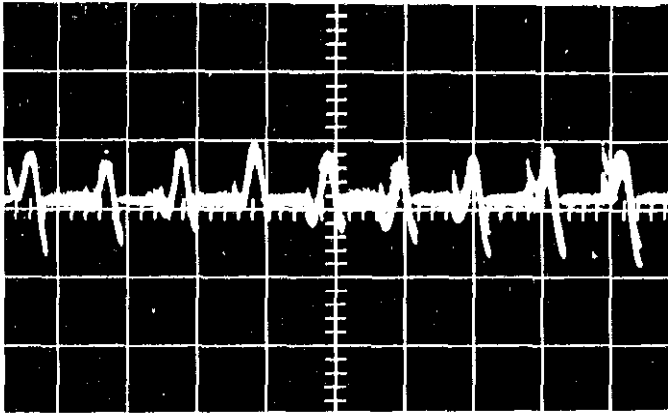

FIGURE 8. Normal Wave Form at Demodulator with Input Shorted. Scale is 0.1 v/cm vertical and 10 msec/cm horizontal.

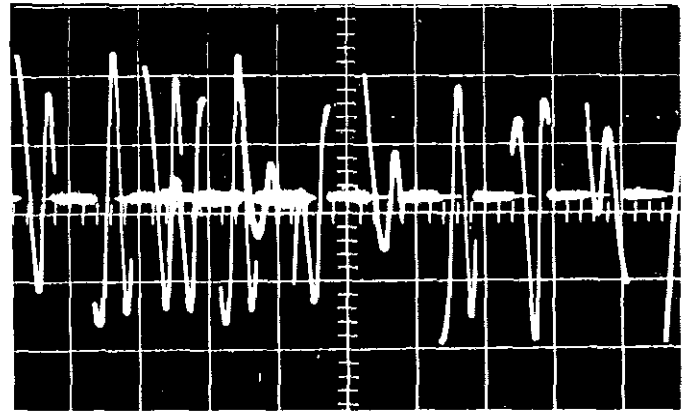

FIGURE 9. Wave Form at Demodulator Shown with Some Pickup. Measurements are adequate; there is no offset but some noise. Scale is 0.5 v/cm vertical and 10 msec/cm horizontal.

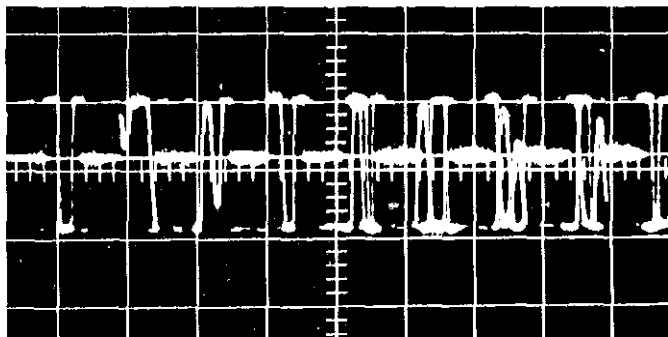

FIGURE 10 (left). Wave Form at Demodulator when Amplifier is Saturated. Dc offset is introduced and there is greater noise. Note that the Null Detector still reacts to the input signal. Scale is 5 v/cm vertical and 10 msec/cm horizontal.

wave form shown in Figure 8. If excessive pickup occurs, the wave form will resemble that of Figure 9. The circuit will operate reasonably well as long as the wave form is not clipped, as shown in Figure 10. At this point a dc offset is introduced.

c. To minimize pickup, keep the circuit away from ac sources. Shield as carefully as possible. Connect all shields together at the low side of the input or at the LO Terminal. The voltage induced due to a magnetic flux is proportional to the area of the loop. Therefore, minimize loop areas in the shield connections as well as the input circuitry. Connect the shield at only one point. Run all wires in the circuit along the same path, so the loop area is only the small difference in position of two adjacent wires.

d. Strong third harmonic magnetic fields — 180 cps for 60-cps units — may create an 8-cps beat at the Null Detector output and meter. To reduce this effect, turn off all possible nearby sources, such as heavy-duty transformers. Remove the Model 147 and the measuring circuit as far as possible from the magnetic field. If removal does not greatly reduce the beat, magnetic as well as electrostatic shielding around the circuit may be necessary. For information concerning your particular shielding problem, contact Perfection Mica Corp., 1322 North Elston Street, Chicago, Illinois.

e. The 8-cps beat will be more apparent at the output terminals, since the meter is filtered. To minimize the beat, use the filter circuit shown in Figure 11. This divides the Null Detector's 1-volt output at full scale to 10 millivolts. The 8-cps beat is reduced by a factor of 10:1. If the 330 microfarads is objectionably large, increase the resistor sizes by 10 times and use a 33-microfarad capacitor. Since the recorder output

is now only 10 millivolts, a non-polar capacitor is not necessary.

f. The Model 147 line frequency rejection refers to the total ac voltage appearing at the input terminals. Therefore, the Null Detector is affected by the sum of the ripple in the working standard and the unknown source. Because of this, working standards having high ac ripple components will significantly reduce the amount of ac voltage which may be tolerated in the unknown.

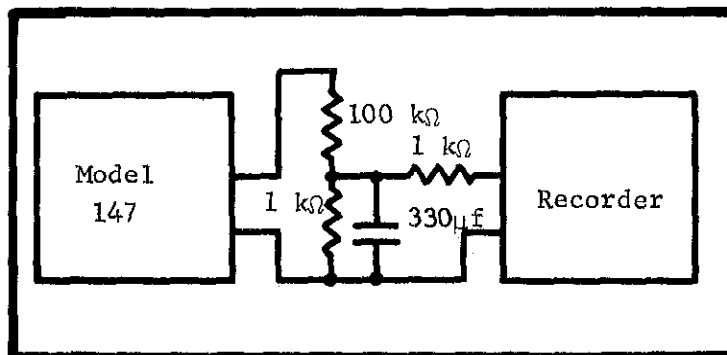

FIGURE 11. 8-cps Filter Circuit for Recorder Output. If the 8-cps beat disturbs the measurements, this circuit will reduce the beat 10:1.

g. Shielding is preferable to input filters. Resistive-capacitive filters add noise (equation 1), and the resistance value must be subtracted from the maximum source resistance in Table 2. Inductive-capacitive filters tend to create loop instabilities within the Null Detector. Capacity alone across the input, however, is less likely to cause loop instabilities, and it may be used to filter ac components in some cases.

2-17. CIRCUIT CONNECTIONS.

a. When measuring in the microvolt and nanovolt regions, consider the effect the physical connections will have on the potential being measured. IR drops, which in most circuits are insignificant, now become important. For example, No. 20 AWG copper wire has a resistance of approximately 10 milliohms per foot. A 1-milliampere current through a 6-inch length of this wire will produce five microvolts. To reduce this drop to 0.5 nanovolt would mean using a wire 0.0006 inch long.

b. Four-terminal connections can often be used to eliminate this error. Refer to Figure 12.

c. If an unwanted IR drop is constant, the zero suppress may be used to nullify the voltage.

d. If the currents or resistances in the measuring system fluctuate, they will develop fluctuating voltages which will appear as noise or drift in the system.

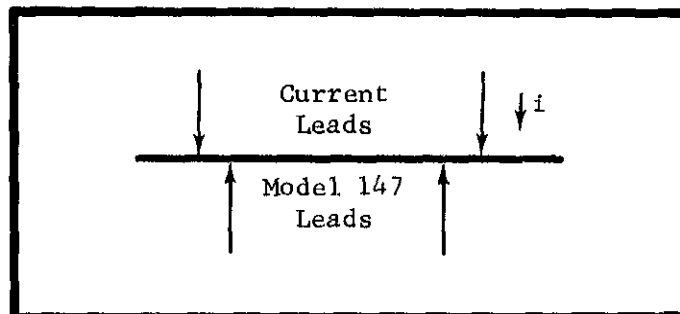

FIGURE 12. Using Model 147 with 4-Terminal Connections.

2-18. OPERATING FROM SOURCE OTHER THAN 117 VOLT, 60 CPS.

a. If the ac power source is 234 volts, use a screwdriver to change the Line Voltage Switch on the back panel (Figure 3). Change the fuse from 1/8 ampere to 1/16 ampere. Use only 250-volt MDL fuses. No other adjustment is necessary.

b. For 50-cps ac power sources, change the sideband filter capacitors, C103 and C104. The Model 147 can operate satisfactorily from 60 or 50-cps sources, but the best ac rejection is achieved when the filter is set for the line frequency. Use Keithley part

C105-.109M (C103) and C45-.0155M (C104) for 50 cps. Refer to Figure 32 for component location.

2-19. RACK MOUNTING. (See Figure 13.)

a. The Model 147 is shipped for bench use with four feet and a tilt-bail. The Model 4002 Rack Mounting Kit converts the instrument to rack mounting to the standard EIA (REIMA) 19-inch width.

b. To convert the Model 147, remove the four screws at the bottom of each side of the instrument case. Lift off the top cover assembly with the handles; save the four screws. To remove the feet and tilt bail from the bottom cover assembly, turn the two screws near

Item (See Fig. 13)	Description	Keithley Part No.	Quantity
1	Cover Assembly	17162C	1
2	Cover Assembly, Bottom (Supplied with Model 147)	17695B	1
3	Angle, Rack	14624B	2
4	Screw, Slotted, 10-32 UNC-2x1/4 (Supplied with Model 147)	---	4
5	Front Panel (Supplied with Model 147)	---	1

TABLE 5. Parts List for Model 4002 Rack Mounting Kit.

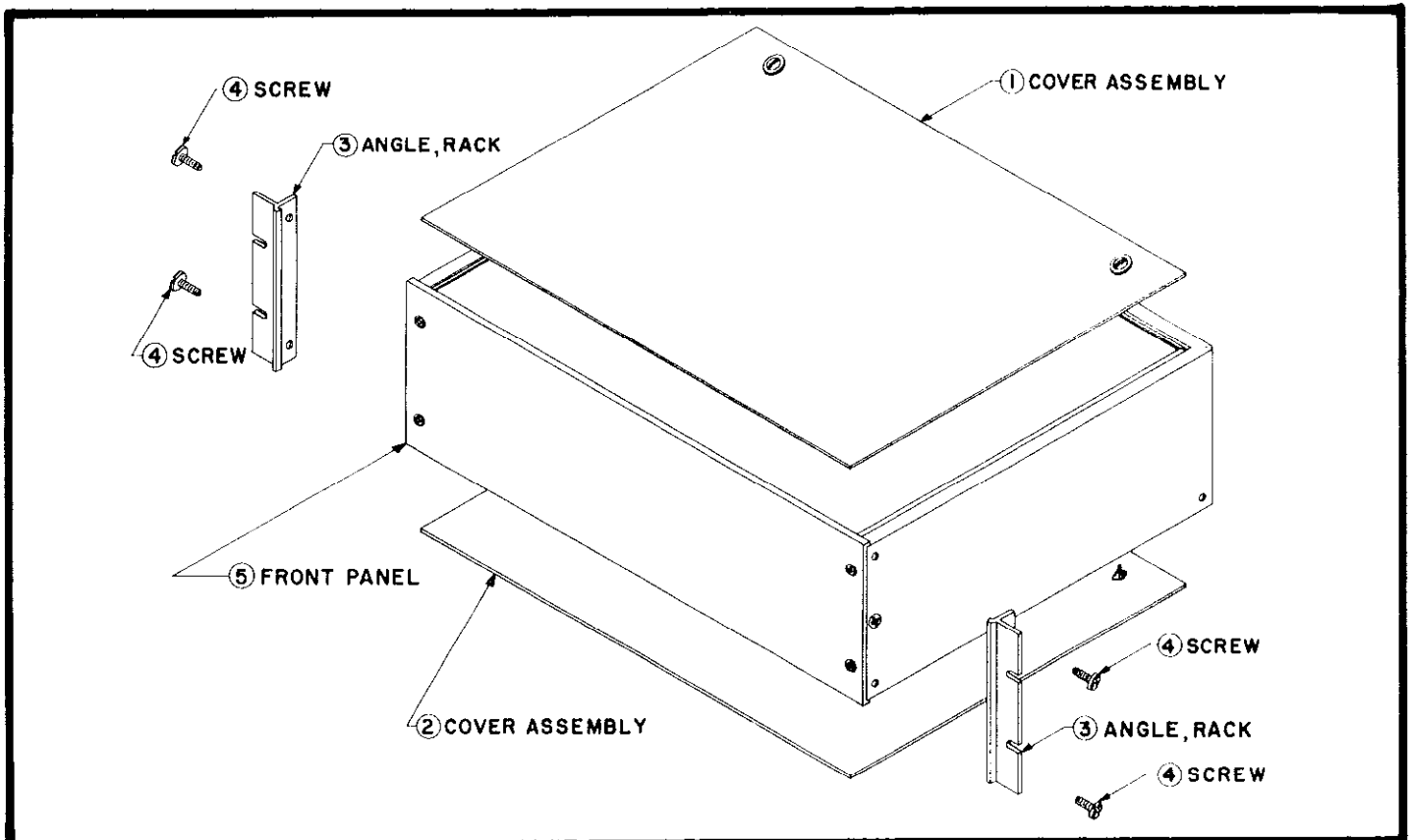

FIGURE 13. Exploded View for Rack Mounting, Using Model 4002 Rack Mounting Kit.

the back. The two pawl-type fasteners will release the cover and allow it to drop off. Remove the feet and the tilt bail and replace the cover (2).

c. Attach the pair of rack angles (3) to the cabinet with the four screws (4) previously removed. Insert the top cover assembly (1) in place and fasten to the chassis with the two pawl-type fasteners at the rear. Store the top cover with handles, feet and tilt-bail for future use.

SECTION 3. APPLICATIONS

3-1. GENERAL. This section contains diagrams using the Model 147 with various potentiometers in null circuits. These are just samples of the circuits available and they do not exhaust all the possible circuits. The setups which follow demonstrate how the Model 147 may be used.

3-2. WORKING SOURCES. The Model 147 permits resolution compatible with the smallest voltage increment available on 6-dial potentiometers. When working at this resolution, use a stable battery working source with the potentiometer. Line-operated working sources are generally limited by several inherent problems — instability, short-term noise of several microvolts, poor line regulation, and several millivolts of ripple. This high ripple may produce dc voltage due to a slight rectifying action at connection points and switch contacts. Also, working sources having high ac ripple components will significantly reduce the amount of ac voltage which may be tolerated in the unknown. This is because the ac rejection of the Model 147 refers to the total ac voltage appearing at its input terminals, and, therefore, is affected by the sum of the ripple voltages in the working source and the unknown source.

NOTE

Follow the operating instructions in Section 2. Pay particular attention to the points brought up in paragraph 2-11 and following.

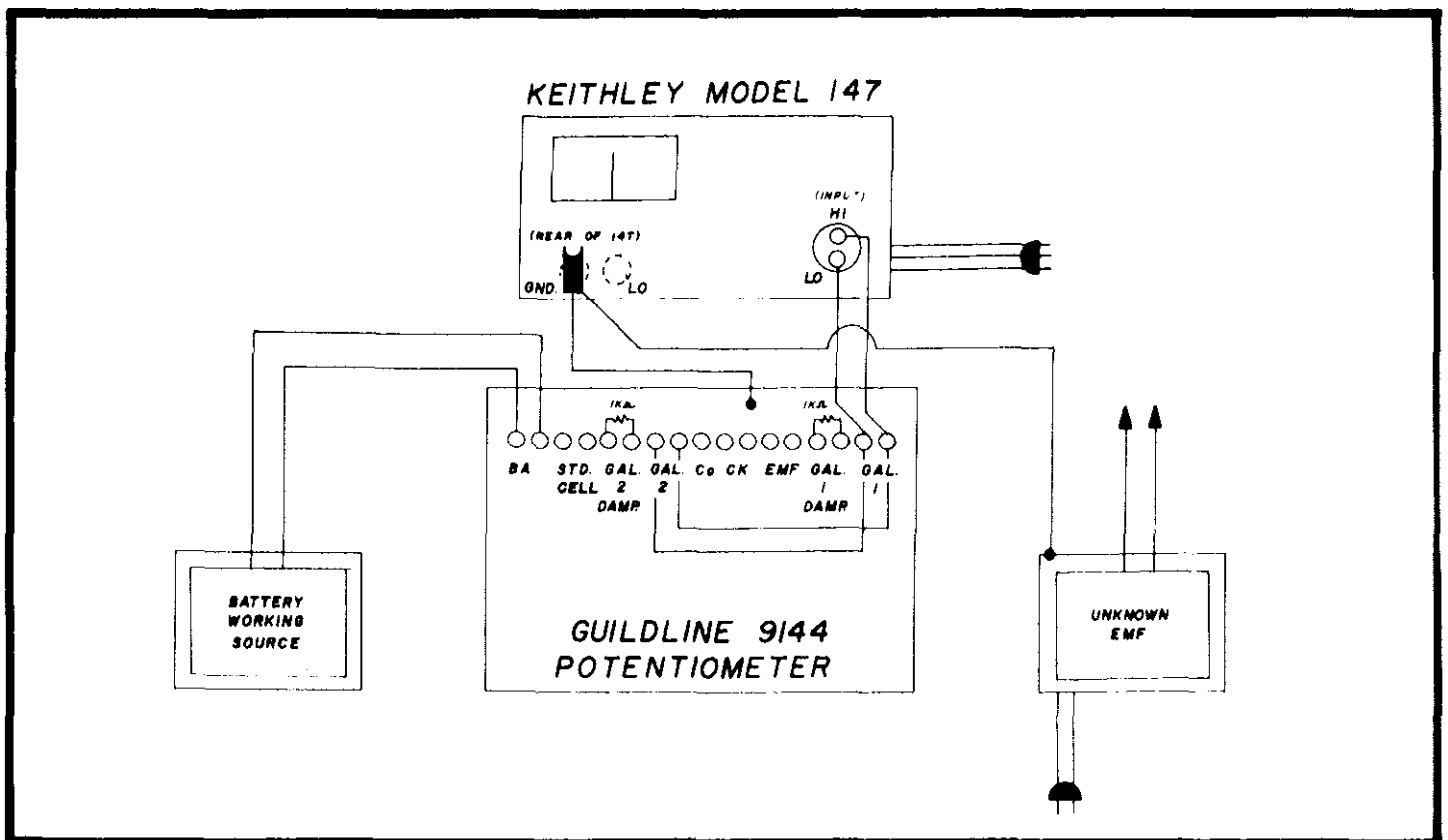

FIGURE 14. Circuit Using Guildline 9144 with Keithley Model 147 Null Detector.

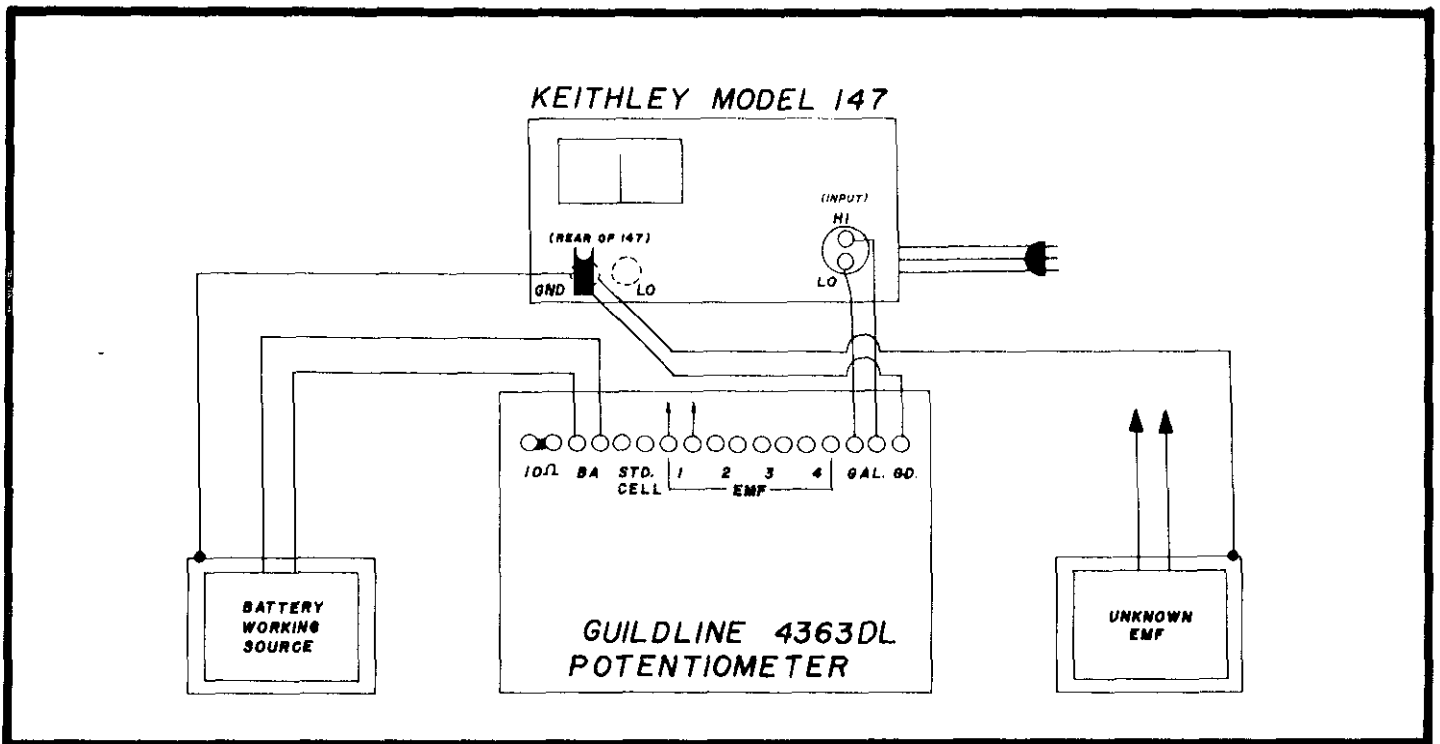

FIGURE 15. Circuit Using Guildline 4363DL with Keithley Model 147 Null Detector.

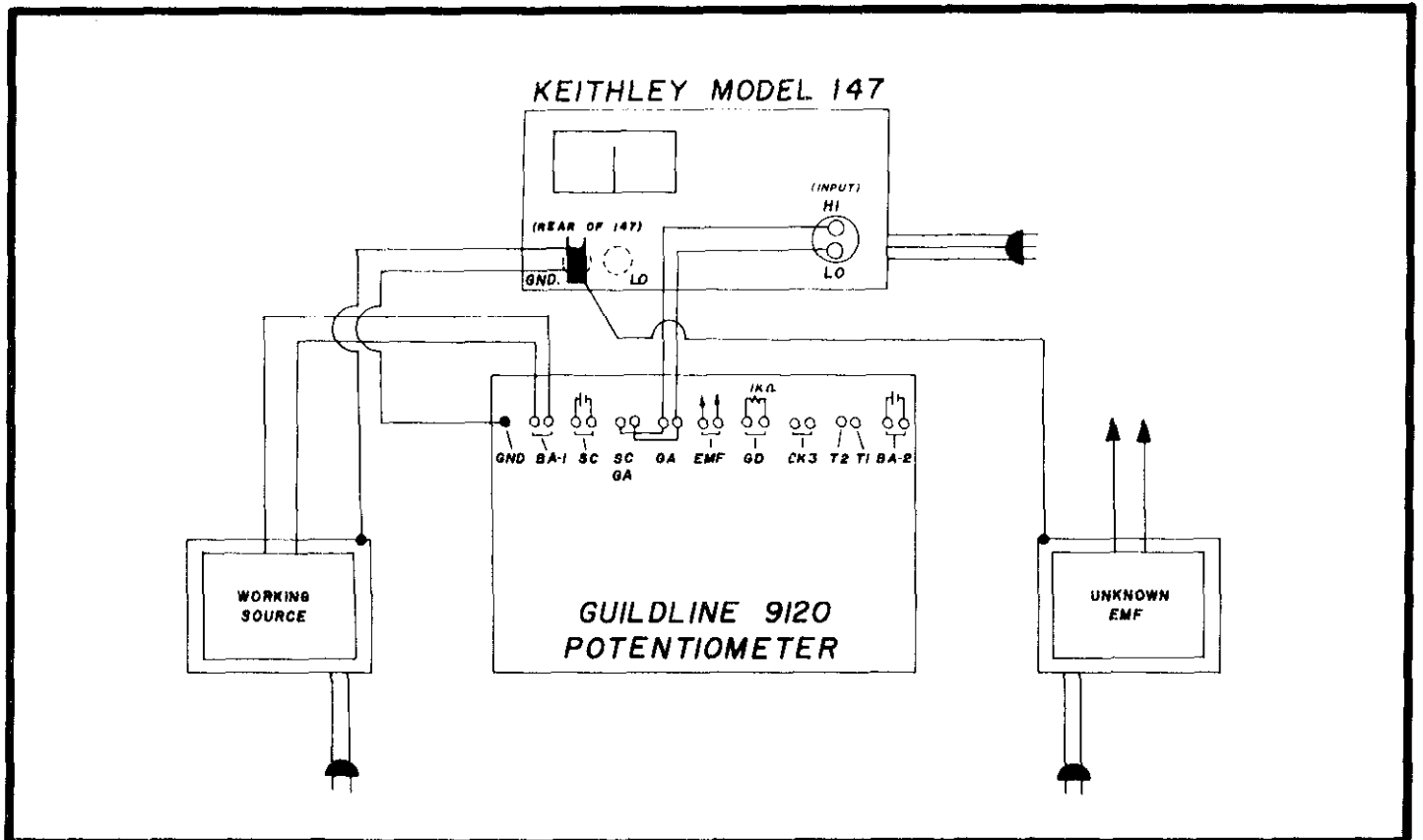

FIGURE 16. Circuit Using Guildline 9120 with Keithley Model 147 Null Detector.

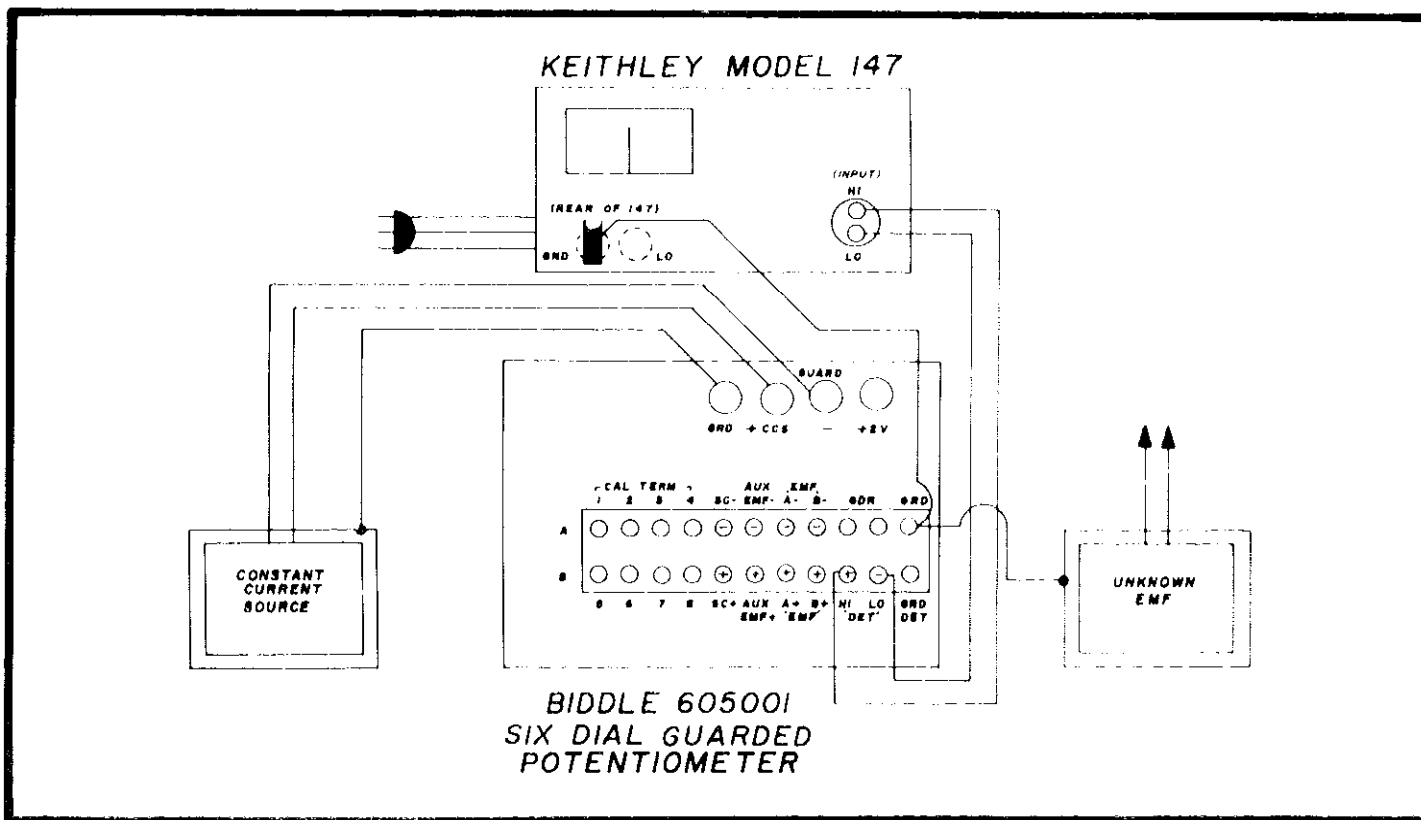

FIGURE 17. Circuit Using Biddle 605001 with Keithley Model 147 Null Detector.

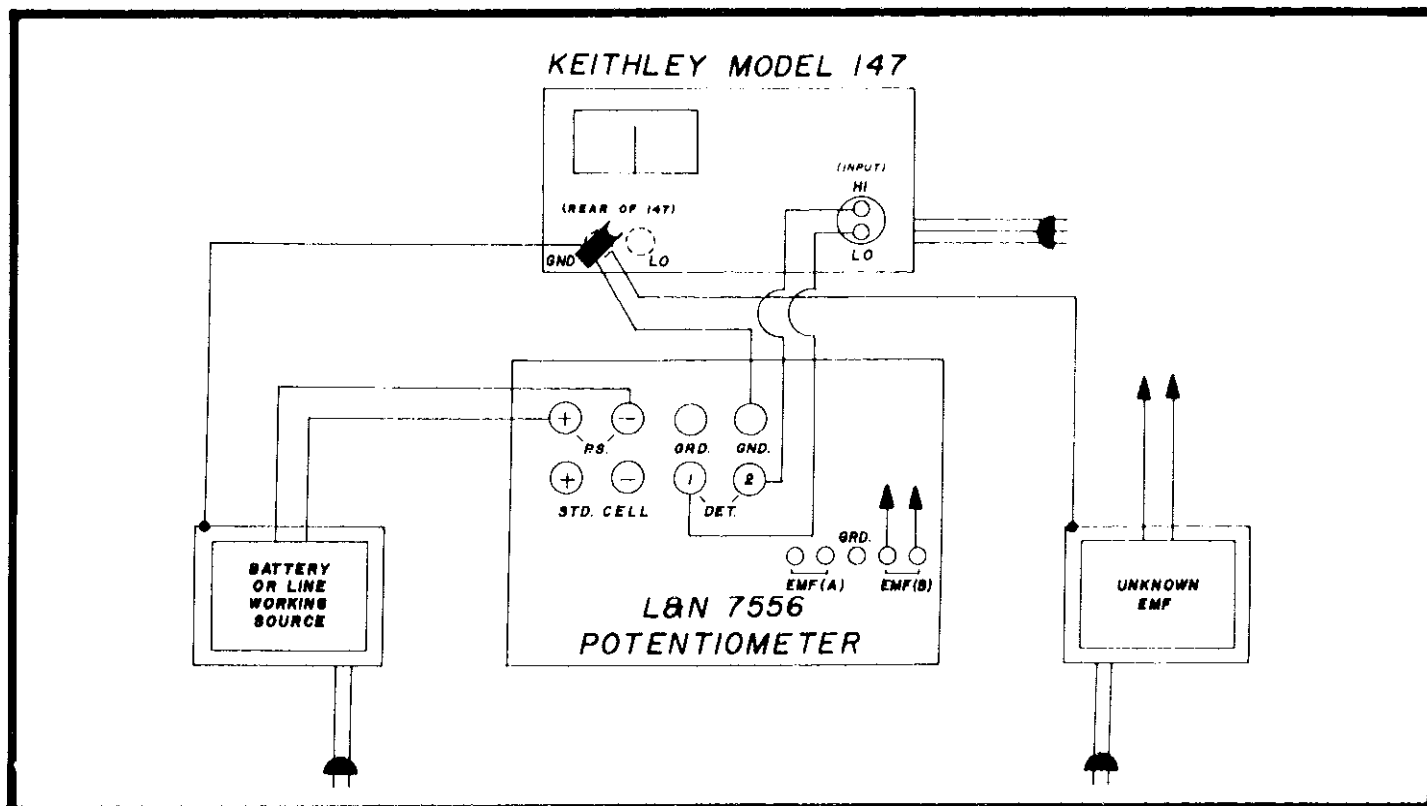

FIGURE 18. Circuit Using Leeds & Northrup 7556 with Keithley Model 147 Null Detector.

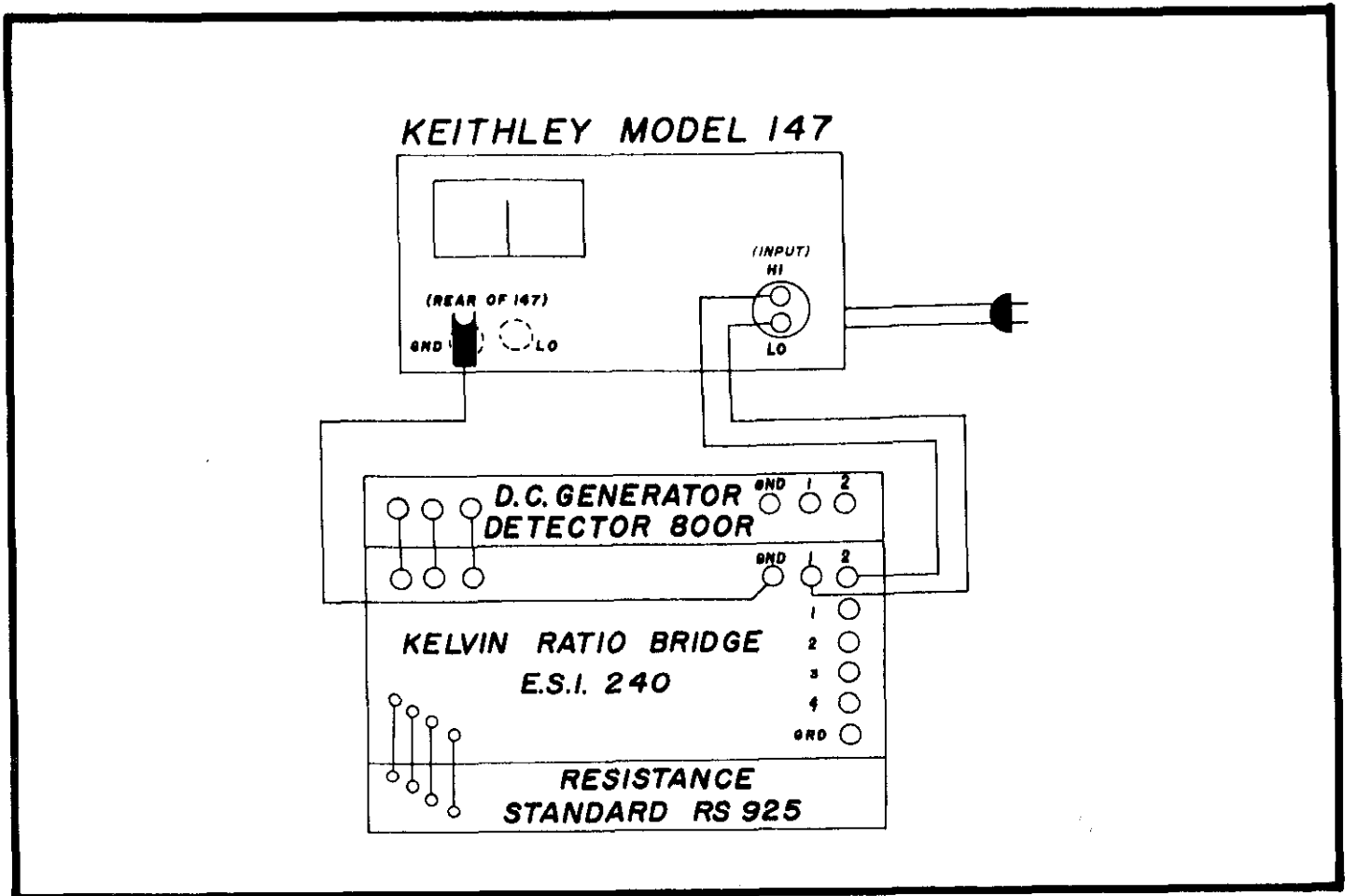

FIGURE 19. Circuit Using Keithley Model 147 Null Detector with ESI 240, 800R and RS 925.

SECTION 4. CIRCUIT DESCRIPTION

4-1. GENERAL.

a. The Model 147 consists of a chopper, ac amplifier and demodulator system followed by a dc amplifier. Feedback is applied to the whole loop. (See Figure 20.)

b. A mechanical chopper converts the dc input signal to a 94-cps signal. The ac signal is amplified, demodulated, dc amplified and applied to the meter. A feedback network samples the signal at the output and compares it to the input. The dc input signal and the feedback signal are compared in the input transformer primary. The transformer increases the voltage-difference signal between the two. The ac amplifier amplifies the difference signal; line-frequency sidebands of the 94-cps signal are filtered out. The ac signal is then demodulated by a saturated transistor switch and enters a dc amplifier, which has a feedback capacitor to filter out the demodulator ripple. The dc amplifier output is connected to the meter, the output terminals and the feedback network. The feedback resistors determine full-scale range. The zero suppress signal is connected to the feedback point in the input circuit.

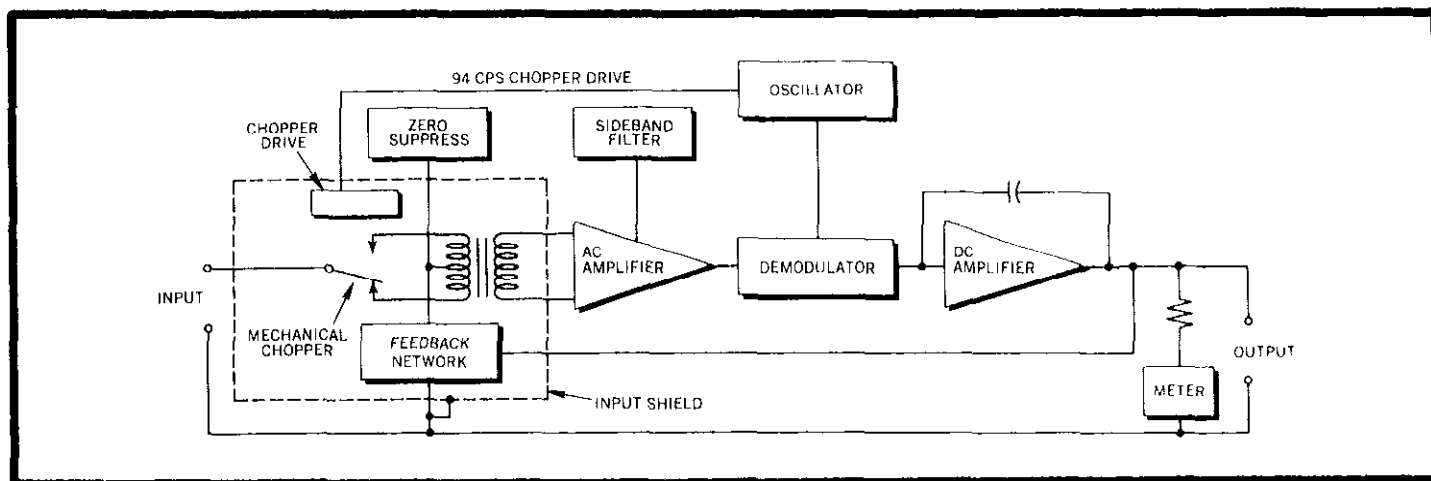

FIGURE 20. Block Diagram of Model 147 Amplifier Circuits.

c. The power source for the Model 147 is either line voltage or the rechargeable battery. Voltage from either source is applied to a dc-to-dc inverter and then to three highly regulated supplies. The three supplies furnish power to the oscillator and the amplifier circuits. There is also a battery charging circuit to charge the battery when it is necessary and when the line voltage is connected.

NOTE

Refer to Schematic Diagrams 18512F, 17352D and 17353D for circuit designations.

4-2. INPUT CIRCUIT.

a. The dc input signal is connected through the high terminal of the INPUT Receptacle, J101, to the center contact of the chopper, G101. (See Figure 21.) The feedback signal

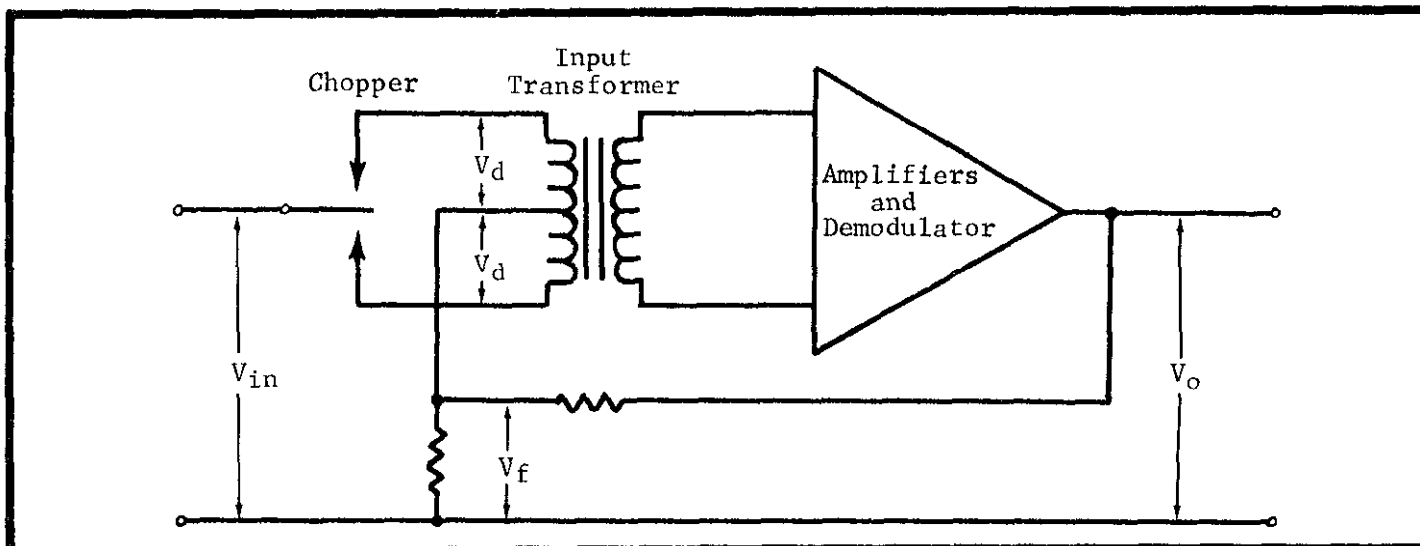

FIGURE 21. Model 147 Input Circuit. The dc input signal, V_{in} , is applied to the chopper. The feedback signal, V_f (the dc amplifier output voltage, V_o , times the feedback ratio, β), is applied to the transformer primary. The signal, V_d , stepped up by the transformer is the difference between the two, $V_d = V_{in} - V_f$. When the dc input signal is initially applied to the Model 147, V_f is zero and the voltage across the primary is entirely V_{in} . As the output voltage rises, V_f increases and V_d decreases to a small value, then $V_f = V_{in}$, or $\beta V_o = V_{in}$. Only β , which depends upon the RANGE and FUNCTION Switch settings, determines the amplifier gain.

is applied to the center tap of the input transformer, T101. The chopper alternately applies a positive and a negative square-wave signal across each half of the primary. The magnitude of the square wave is proportional to the difference between the dc input and the feedback signals. T101 steps up this signal and applies it to the grid of tube V1.

b. The input compartment is designed to insure high thermal stability and to minimize internal ac pickup.

1. Thermal stability is obtained in part by using only copper wire in the input circuitry. The input transformer primary and the chopper leads are pure copper. The input receptacle is 99.5% copper; the impurities add to the mechanical strength without creating large thermal emf's. The low voltage portion of the FUNCTION Switch uses pure copper pins and rotor. All connections to components are made with pure copper crimp lugs. Connections between components are made by bolting the lugs together — not soldering — to reduce thermal emf's.

2. The input compartment is doubly shielded against magnetic and electrostatic pickup on all sides. The wires are physically placed to maintain minimum loop area, further minimizing pickup.

c. The feedback network is formed from the output of the dc amplifier back to the center tap of the primary of transformer T101. The RANGE Switch, S102, selects the feedback ratio used for each range.

4-3. AC AMPLIFIER.

- a. The ac amplifier circuit amplifies the 94-cps difference signal which corresponds

to the dc input signal. The signal is applied to the grid of tube V1 and further amplified by tube V2. A low-noise silicon transistor, Q3, provides a high impedance load for V2. The signal is then amplified by transistors Q4 and Q6. Potentiometer R109, between the Q3 emitter and Q4 base, adjusts the gain to compensate for beta variations. In addition, each stage has some local degeneration. Transistor Q5 is for impedance matching. The difference signal is amplified by transistors Q7 and Q8, which also form a full-wave signal for demodulation.

b. A series high-Q filter from the plate of V2 to circuit ground provides notch rejection at the power-line frequency sidebands. The values of capacitors C103 and C104 depend upon the power-line frequency. Due to the high Q of the inductor, the filter forms sharp notches at 34 cps and 154 cps for 60-cps power lines and 44 cps and 144 cps for 50-cps power lines. The ac amplifier's 94-cps gain and phase characteristics are affected very little.

c. The tube type and bias point of V1 are selected for low-noise operation at 94 cps. The high-Q tuned circuit in the plate of V1 has a good signal-to-noise ratio, and it provides a narrow bandwidth around 94 cps. The tuned circuit's Q is lowered on the higher ranges for amplifier stability.

4-4. DEMODULATOR. Transistors Q9 and Q10 in inverted configuration form a transistor switch demodulator. They convert the 94-cps wave from the ac amplifier into a dc voltage with ripple component. Resistors R123 and R124 sum the voltages from each to form a full-wave rectified signal. Jack J102 allows access to observe the wave form. The 94-cps oscillator furnishes a square-wave drive for the demodulator.

4-5. DC AMPLIFIER.

a. The demodulator signal is amplified by two low-drift, high-gain silicon transistors, Q11 and Q12, in differential configuration to compensate for temperature drift. Transistors Q13 and Q14 form the second amplifier stage. Total gain is about 500. The emitter follow output stage — transistors Q15 and Q16 in pnp-npn configuration — draws little current at zero output. Diodes D101 and D102 limit the output current, protecting transistors Q15 and Q16.

b. A feedback loop with capacitor C115 around the dc amplifier acts as an integrator, filtering the ripple component of the demodulated wave form. The effective capacity, which is approximately the value of C115 times the dc amplifier gain, and the feedback factor (or open-loop gain) determine the response speed of the system. The capacitive feedback also lessens the noise in the amplifier outside the system bandpass.

4-6. OSCILLATOR. The oscillator circuit, stable to 0.1 cps, has three parts: phase-shift network for a 94-cps signal, an amplifier to drive the chopper, and a transistor switch and phase compensation network for the square-wave demodulator drive.

a. The phase-shift network consists of capacitors C301 through C303, resistors R319 through R321, and the combined resistance of R303 and R318, which bias transistor Q17. The input impedance of the emitter follower, Q17, has little loading effect on the effective value of this last resistance. Transistor Q18 compensates for signal losses in the phase-shift network. Potentiometer R319 adjusts the signal frequency. Resistor R322, the filament of a low-power subminiature tube, Raytheon CK544, provides variable degeneration to maintain a sine wave output to the amplifier.

b. From the phase-shift network, the signal is amplified and used to drive the chopper. Transistor Q19 matches the impedance of transistor Q20 to the phase-shift network. Potentiometer R313 adjusts the signal amplitude. From transistor Q20, the signal is applied to the primary of transformer T301, which drives the class B stage, transistors Q22 and Q23. After amplification the sine-wave signal is applied to the chopper, G101. Transistor Q21 develops the bias voltage for the class B stage, providing ambient temperature compensation for the chopper-drive signal amplitude. The center taps of transformers T301 and T302 supply dc current for the class B stage.

c. The chopper drive signal is also applied to the primary of transformer T302. The transformer drives transistors Q24 and Q25 through a phase-compensating network, resistors R308 to R310, R323 and capacitor C309, which compensates for the chopper phase shift. The transistors alternate between saturation and cut off to form a square-wave drive for the demodulator, transistors Q9 and Q10.

4-7. ZERO SUPPRESS.

a. The zero suppress circuit provides a regulated voltage from the power supplies to buckout steady background potentials in the input signal. The 10-turn FINE Control, potentiometer R168, is connected between +12 and -12 volt outputs. The resistors R165 to R167 and R172 in the COARSE Switch, S103, further divide the voltage. The suppress voltage is divided by an Evenohm 0.25% resistor, R140, copper resistor R137A, and copper resistor R141. Using copper resistors for the lowest voltage points shunted by Evenohm resistors provides thermal and resistive stability.

b. An adjustable current, supplied through resistor R138, provides compensation for resistive offset. Potentiometer R239 adjusts the current fed to the feedback point.

4-8. POWER SUPPLIES (See Figure 22.) The power supply for the Model 147 is powered by an unregulated supply from the line voltage or rechargeable battery. Either source feeds a dc-to-dc inverter and three highly regulated supplies with outputs of +12, -12, and +1.2 volts. These power all the other Model 147 circuits.

a. The line voltage, battery and battery charging circuit are controlled through the POWER SUPPLY Switch, S201. When the switch is in AC, the battery is charged if necessary and the power supply uses line voltage. When the switch is in OFF, the battery charging circuit will operate if necessary; all other circuits are off. When the switch is in BATTERY, the power supply uses the battery; the other two circuits can not operate.

b. The unregulated supply consists of a full-wave rectifier, diodes D212 and D213, and a dropping resistor, R232. The AC CONNECTED Lamp, DS201, is in series with resistor R226, which is connected directly across this supply. For battery operation the primary of transformer T201 is disconnected.

c. Voltage from the unregulated supply or the battery is applied to the dc-to-dc inverter circuit. Transistors Q28 and Q29 form a switching network to supply an interrupted voltage to transformer T202. The switching frequency is about 2 kc, well away from the carrier frequency. Transformer T202 has a saturable ferrite core. The inverter circuit supplies voltages to the three regulated supplies, which are basically the same series regulator design.

d. For the +12 volt supply, diodes D206 and D207 full-wave rectify the signal from transformer T202. The signal is applied to the pass transistor, Q30. The output of Q30 is divided by resistors R208 and R209 and compared to the zener diode reference, D205.

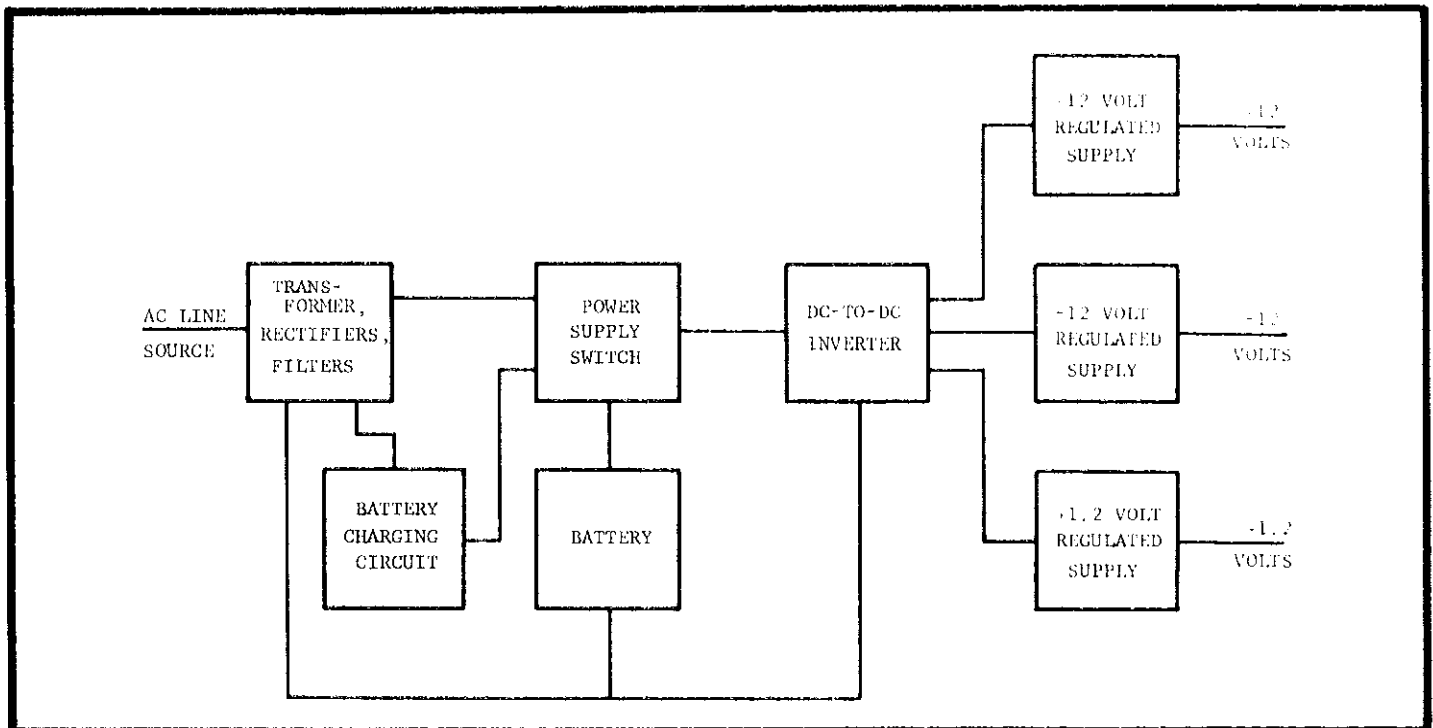

FIGURE 22. Block Diagram of Model 147 Power Supplies and Battery Charging Circuit.

Transistors Q34 and Q33 amplify any potential difference and apply a signal to the base of transistor Q32. Diodes D204 and D205 fix the emitter voltage of Q32; therefore, the collector voltage of Q33 directly determines the current through Q32, which comes from the -12 volt supply. The current drop through resistor R216 determines the voltage at the base of transistor Q31, and therefore the output voltage through the base-emitter junction. Diode D203 limits the base-to-emitter voltage of the Q30 and Q31 combination, thus also limiting the current which it will pass. Diode D203 protects the pass transistor Q30, if the output of the supply is shorted.

e. For the -12 volt regulated supply, diodes D210 and D211 full-wave rectify the signal from transformer T202. The signal is applied to the pass transistor, Q35. Resistors R217 and R218 divide the Q35 output, thereby comparing it to the +12 volt supply, using ground as a reference. Transistors Q38 and Q39 amplify any potential difference and apply a signal to transistor Q37. Transistors Q35 and Q36 form a Darlington combination, and work similarly to that in the +12 volt supply. The differences are that the -12 volt supply draws a higher current than the +12 volt supply, and therefore uses two diodes, D208 and D209, to protect the pass transistor. The negative "bootstrap" current supply is from a filter, resistor R225 and capacitor C210.

f. The +1.2 volt supply operates in the same manner as the +12 volt supply with these differences. The output of the pass transistor, Q40, is compared to the output of the +12 volt supply divided down one tenth. The operating voltages for the comparator stage, Q43 and Q44, are obtained from the +12 and -12 volt supplies. Except for the comparator stage, npn transistors are used.

4-9. BATTERY CHARGING CIRCUIT.

a. The battery charging circuit operates when the POWER SUPPLY Switch, S201, is in AC or OFF position, and only when the battery needs charging.

b. The battery voltage is compared to a reference by two cascaded transistors, Q26 and Q27. When it is low, a charging current from transformer T201 is applied to the battery through the BATTERY CHARGING Lamp, DS202, transistor Q27 and diode D216. The reference is zener diode D214; the reference voltage is adjusted by potentiometer R228. The difference between the battery and the reference potentials determines the magnitude of the charge current through Q27. A silicon diode, D216, prevents the battery from being run down because of leakage currents through Q27, a germanium power transistor. Diode D215 limits the base-to-emitter voltage of the Q26 and Q27 combination, so no more than 400 milliamperes (the rated maximum charge current of the battery) can flow in the circuit.

c. This circuit protects the battery. It decreases the charging current to a trickle-charge rate as the battery terminal voltage approaches the reference voltage. It also limits the charge current if the battery was used beyond its ampere-hour capacity. Note, however, that the battery can be damaged if it is used far beyond its capacity. A polarity reversal of a cell may occur, causing heavy circulating currents within the battery.

SECTION 5. MAINTENANCE

5-1. GENERAL. Section 5 contains the maintenance, troubleshooting and calibration procedures for the Model 147. It is recommended these procedures be followed as closely as possible to maintain the instrument's specifications.

5-2. MAINTENANCE SCHEDULE.

a. The Model 147 requires no periodic maintenance beyond the normal care required of high-quality electronic equipment. Components operate well below maximum ratings. Principal maintenance is an occasional chopper replacement. (See paragraph 5-4.)

b. Suggested Model 147 calibration schedule is as follows:

1. Every four to six months, check the Model 147 with the Keithley Model 260 Nanovolt Source. This will show if the Null Detector is maintaining its specified accuracy.
2. Approximately every year, perform an operational check on the amplifiers (paragraph 5-10). This will indicate how well the Null Detector is operating.
3. Normally, the Model 147 does not need recalibrating unless critical components are replaced. These part changes are called out by the various circuits in this Section.

5-3. PARTS REPLACEMENT.

a. The Replaceable Parts List in Section 6 describes the electrical components of the Null Detector. Replace components only as necessary, and use only reliable replacements which meet the specifications. The Model 147 uses few special parts except for resistor R322, which is a subminiature tube filament, the components listed in Table 6, several matched transistors (Q11, Q12, Q22, Q23) and the two input tubes. Make sure parts coded 80164 in the Replaceable Parts List are purchased only from Keithley Instruments or its representative. (If the Low-Thermal Function Switch, S101, needs replacement, return the unit to Keithley Instruments for this repair).

Component	Circuit Desig.	Keithley Part No.
Battery pack assembly	BA201	Model 1489
Mechanical chopper assembly (See paragraph 5-4.)	G101	17689A
Input receptacle assembly	J101	17638A
Copper feedback resistor assembly	R137	17627A
Evanohm resistor assembly	R139	17635A
Evanohm resistor assembly	R140	17636A
Function switch plate assembly (see paragraph 5-3a)	S101	16883A
Input transformer assembly	T101	18435B

TABLE 6. Model 147 Pre-assembled Components. These parts have lugs crimped on them and the proper lead length. Use only Keithley parts for replacements; follow instructions given in paragraph 5-3.

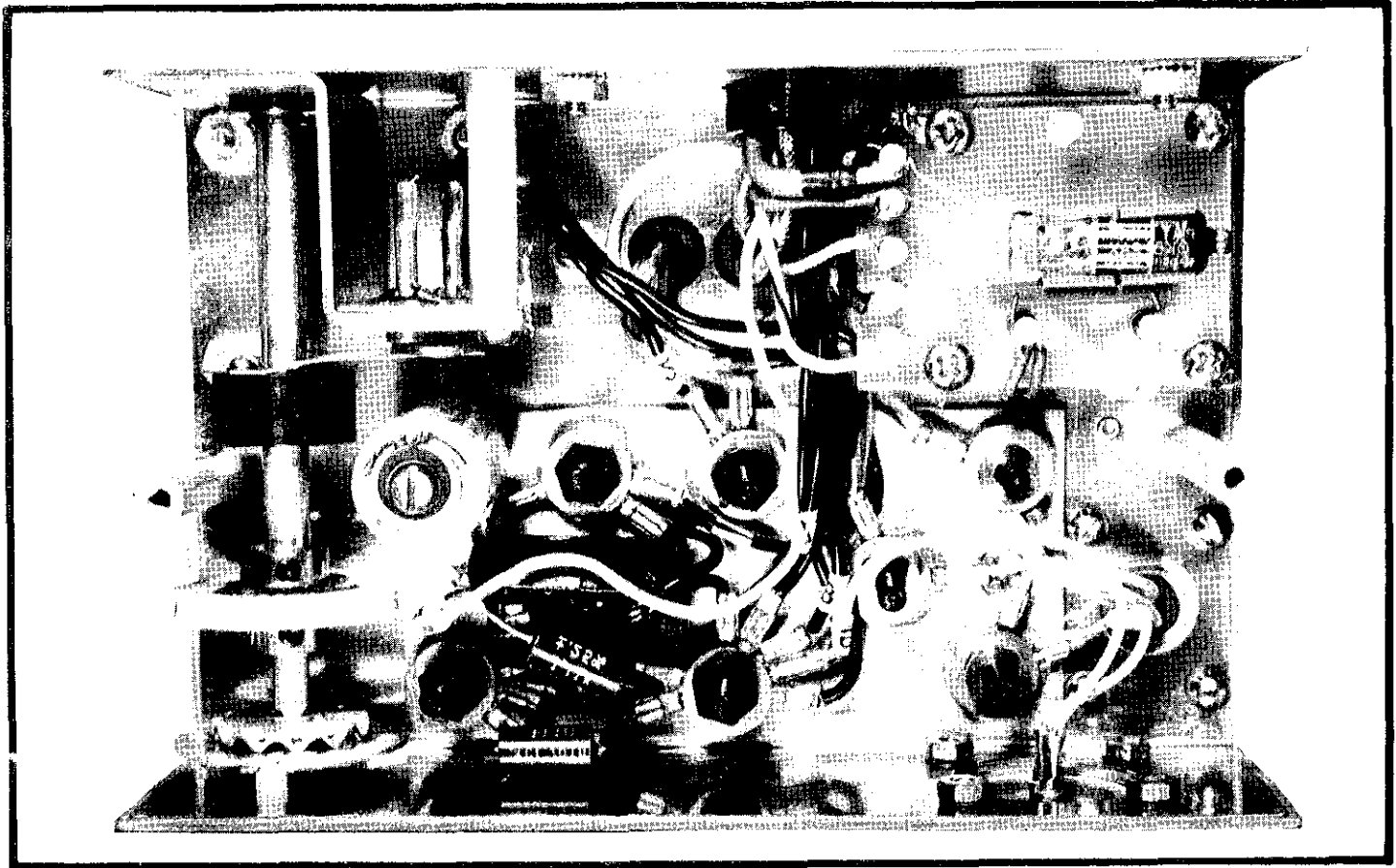

FIGURE 23. Model 147 Input Compartment. Note exact physical location of parts. If replacing, duplicate location and order of leads on posts. Figure 30 gives circuit designations. Refer to Figure 7 for general connection construction.

b. The physical location of components in the input compartment is critical. Place replacement parts in the exact position shown in Figure 23. Circuit loops will introduce extraneous ac signals; see paragraph 2-15. The order of the copper lugs on the insulated posts greatly affects offset and noise in the Model 147. Tag or record the number on each lead as it is removed. Replace in reverse sequence. Maximum torque applied to the No. 6 Kep nuts in the input compartment is 15 inch-pounds. Table 6 lists components which have lugs crimped on them. When replacing these parts, clean the lug with a non-metallic abrasive, such as Scotch Brite, found in the Model 1483 Kit, or its equivalent. Follow the procedures necessary for good low-thermal connections.

5-4. CHOPPER REPLACEMENTS.

a. The chopper is designed for long life. However, since it is mechanical, it will eventually wear and become noisy. At this point, replacement is necessary.

b. Removal Procedures.

1. Disconnect the chopper drive coil at connector J302 (Figure 29). Carefully remove the three thumb screws in the input compartment and the three chopper lead lugs.

2. Carefully slide the degaussing coil, L302 (Figure 29), from the chopper body; remove the old chopper.

c. Replacement Procedures.

1. Slide the degaussing coil, L302, over the new chopper body from the bottom. Orient so that the cut-out in the coil fits over the chopper drive lead.

2. Mount the chopper and coil in the input compartment. Dress leads as shown in Figure 23.

3. Check the instrument for proper operation. Follow paragraph 5-10 subparagraph b, steps 1, 2 and 3.

d. Degaussing Coil Adjustment Procedures.

1. With the input shorted, use the ZERO SUPPRESS Controls to cancel any thermal emf's in the Model 147 input circuit. Use a differential input to the Type 503 Oscilloscope (+ and - inputs) to observe the wave form between the collectors of transistors Q9 and Q10 (Points P and Q, Figure 34).

2. The wave form amplitude varies as the degaussing coil is moved along the chopper body. Potentiometer R301 (Figure 30) determines the effect of the coil on the wave form. Adjust both the coil and the potentiometer for minimum amplitude. Reverse the red and black leads to the degaussing coil if necessary.

3. An 8-cps beat at points P and Q may be present. Use battery operation to reduce the beat; refer to paragraph 2-3.

5-5. TROUBLESHOOTING.

a. The following procedures give instructions for repairing troubles which might occur in the Model 147. Use these procedures to troubleshoot and use only specified replacement parts. Table 7 lists equipment recommended for troubleshooting. If the trouble cannot be readily located or repaired, contact Keithley Instruments or its representatives. Paragraph 2-19 describes how to remove the Null Detector cover.

b. Paragraphs 5-8, 5-9 and 5-10 give step-by-step procedures for troubleshooting and checking out the power supply, oscillator and amplifier circuits. Follow these in the order given. Tables 10, 11 and 13 are troubleshooting tables for these circuits. Also refer to Section 4 to find the more crucial components and to determine their function. The Schematic Diagrams, 18512F, 17352D and 17353D, contain the voltages at certain points in the circuit.

NOTE

Before troubleshooting inside the Model 147, check the external circuits (paragraph 5-6). Always check out the power supply and the oscillator circuits before touching the amplifier circuits. The amplifier circuits often appear faulty only because of a defect in the power supply or oscillator circuits.

Instrument	Use
Hewlett-Packard Model 5512A Electronic Counter, 300-kc counting rate, $\pm 0.1\%$ accuracy	Monitor oscillator frequency
Keithley Instruments Model 1488 Low-Thermal Shorting Plug	Short INPUT Receptacle
Keithley Instruments Model 260 Nanovolt Source	Signal source for calibrating Model 147
Keithley Instruments Model 2603 Low-Thermal Input Cable	Connect Models 147 and 260
Keithley Instruments Model 660 or 660A Guarded DC Differential Voltmeter, $\pm 0.02\%$, to 1 millivolt	Check voltage at output terminals
RCA Model WV98B Senior Volttohyst, 11 M Ω input resistance, $\pm 3\%$ accuracy, 0 to 1500 volts dc	Check dc voltages throughout circuit
Tektronix Type 503 Oscilloscope, dc to 450 kc	Check wave forms for troubleshooting and calibrating

TABLE 7. Equipment Recommended for Troubleshooting and Calibrating the Model 147. Use these instruments or their equivalents.

5-6. PRELIMINARY TROUBLESHOOTING PROCEDURES.

a. Before troubleshooting, check the outside circuits to the Model 147. Isolate the Null Detector from all external effects:

1. Disconnect all outside circuits from the INPUT and OUTPUT Receptacles, and GND and LO Terminals.

2. Connect the Model 1488 Shorting Plug to the INPUT Receptacle. Set the ZERO SUPPRESS COARSE Control to OFF.

b. If battery operation is trouble free, set the POWER SUPPLY Switch to BATTERY. Disconnect the power cord from the ac power line. Ground the Model 147 case to a convenient earth ground or to a common test equipment ground.

NOTE

Often, after checking out according to paragraph 5-6, the Model 147 will function normally. This points to problems in the circuits outside the Null Detector. Refer to Table 4 to check the external circuit.

c. If ac operation is used, check the Line Voltage Switch for correct position and the Fuse for correct rating.

Control	Circuit Desig.	Fig. Ref.	Refer to Paragraph
ac amplifier gain adjust	R109	34	5-10
meter adjust	R136	34	5-10
battery charging adjust	R228	36	5-8
current compensation adjust	R239	29	5-11
degaussing coil compensation	R301	30	5-4
oscillator amplitude adjust	R313	37	5-9
oscillator frequency adjust	R319	37	5-9

TABLE 8. Model 147 Internal Controls. The Table lists all internal controls, the figure picturing the location, and the paragraph describing the adjustment.

5-7. CHECK OUT AND CALIBRATION PROCEDURES.

a. The following procedures give the steps to check out and calibrate the Model 147 circuits. If a circuit fails to check out at any point, refer to the circuit's troubleshooting table. Continue as long as the points check out. Use the equipment listed in Table 7.

b. Procedures are given for the power supply, oscillator and amplifier circuits. These cover the principal adjustments to bring the instrument within specifications.

c. If the Model 147 is not within specifications after performing these checks and calibrations, contact Keithley Instruments or follow the troubleshooting procedures to find the fault.

NOTE

Make sure the power supply and oscillator circuits are operating correctly before checking the amplifiers. All circuits depend upon properly functioning power supplies. If taken out of order, the resulting adjustment may be faulty.

5-8. POWER SUPPLY CHECK OUT AND CALIBRATION.

a. All circuits depend upon the power supplies. Therefore, the +12, -12 and +1.2 volt outputs must be correct before further checks are made. If the power supplies fail to check out at any point, refer to Table 10. After clearing the trouble, continue the check.

b. Procedures for Checking Regulated Power Supplies.

1. Connect the Model 1488 Shorting Plug to the INPUT. Set the Model 147 controls as follows:

- | | |
|------------------------------|---------------------|
| POWER SUPPLY Switch | OFF |
| RANGE Switch | 100 |
| FUNCTION Switch | MILLIVOLTS |
| ZERO SUPPRESS COARSE Control | OFF |
| Line Voltage Switch | Set to line voltage |

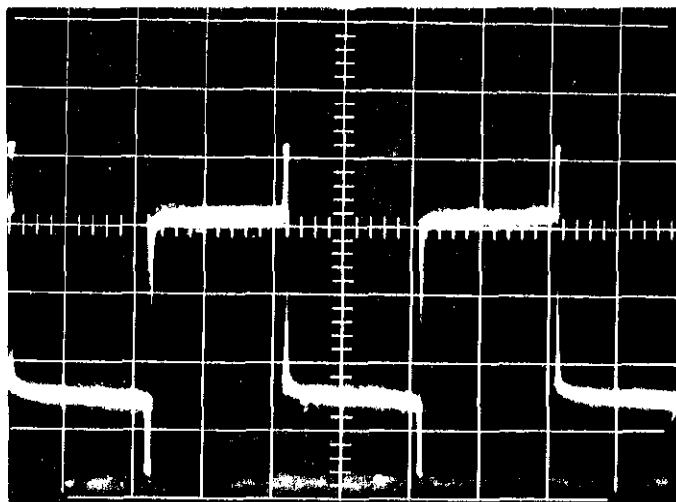

FIGURE 24. Correct Wave Form in dc-to-dc Inverter. Point E, Figure 35, was monitored. Scale is 5 v/cm vertical, 0.2 msec/cm horizontal.

2. Plug in the power cord. The AC CONNECTED Lamp should light.

3. Measure the voltage at the Yellow-White wire on the POWER SUPPLY Switch front deck (Point A, Figure 29). It should be -18 volts dc \pm 2 vdc.

4. Turn the POWER SUPPLY Switch to AC. Use the oscilloscope to check the wave form at point E (Figure 35) in the dc-to-dc inverter. Wave form should resemble that in Figure 24.

5. Measure the signal levels and ripple with respect to low of the three regulated supplies. Table 9 gives the values.

c. Procedures for Charger Circuit.

1. Disconnect the battery pack; do not let the terminals touch the chassis.

Connect the Null Detector to the ac power line. Put the POWER SUPPLY Switch in AC position.

2. Set the charger bias voltage to -8.1 volts dc (measured with \pm 3% voltmeter) at point G, Figure 35. Adjust potentiometer R228 (Figure 36) for this value.

3. Connect the battery; make sure the polarity is correct (red to red). The positive side of the battery is ground. The BATTERY CHARGING Lamp should light, showing the charging circuit works. The lamp brightness directly indicates the charge current — the brighter the light, the greater the current.

Regulated Power Supply	Test Point, Figure 30	Signal Level, volts dc	Maximum Ripple, millivolts peak-to-peak	Resistance to Ground, ohms
+12 volt	B	11.6 to 12.8	0.3	850 \pm 100
-12 volt	C	11.9 to 13.1	2.0	460 \pm 70
+1.2 volt	D	1.16 to 1.28	0.2	20 \pm 3

TABLE 9. Signal Level, Maximum Ripple and Resistance for Regulated Power Supplies. Use the oscilloscope and the Voltohmyst for the measurements.

TROUBLE	PROBABLE CAUSE	SOLUTION
No voltage at point A (Fig. 29)	Blown fuse.	Check for shorted transformer T201 or wiring; then replace fuse.
	D212, D213 or R232 open.	Check components; replace if faulty.
Irregular wave form at point E (Fig. 35)	Overloaded regulators	Check resistances at power supply test points. (See Table 9.)
	Defective Q28 and/or Q29	Check components; replace if faulty.
Incorrect voltage at points B, C and D (Fig. 30)	Defective D205, Q33, Q34, Q38 (or Q39), D204, D212	Check components; replace if faulty.
Incorrect voltage only at point D (Fig. 30)	Shorted V1 or V2 filaments	Check V1 and V2 filament.
	Defective Q43 or Q44	Check components; replace if faulty.
High ripple at points B, C and D (Fig. 30)	Defective oscillator	See paragraph 5-9.
	Defective D204, D212, D205, Q33, Q34, Q38 or Q39.	Check components; replace if faulty.
High ripple only at point D (Fig. 30)	Defective Q43 and/or Q44.	Check components; replace if faulty.
Unable to adjust for -8.1 volts at point G (Fig. 35)	Defective D214, R227, R228, R229 or Q26	Check components; replace if faulty.
High ripple at points B, C and D (Fig. 30) on battery operation only	Low battery voltage	Charge battery (paragraph 2-4).

TABLE 10. Troubleshooting Table for Power Supply and Battery Charging Circuits.

4. After connecting the battery pack, the bias voltage may change. This is normal and no re-adjustment is required.

5-9. OSCILLATOR CHECK OUT AND CALIBRATION.

a. The oscillator circuit drives the demodulator and the chopper. If the power supplies check out, check the oscillator. If the oscillator fails to check out at any point, refer to Table 11. After clearing the trouble, continue to the amplifiers.

b. Procedures.

1. Connect the oscilloscope and the electronic counter to point F (Figure 30).

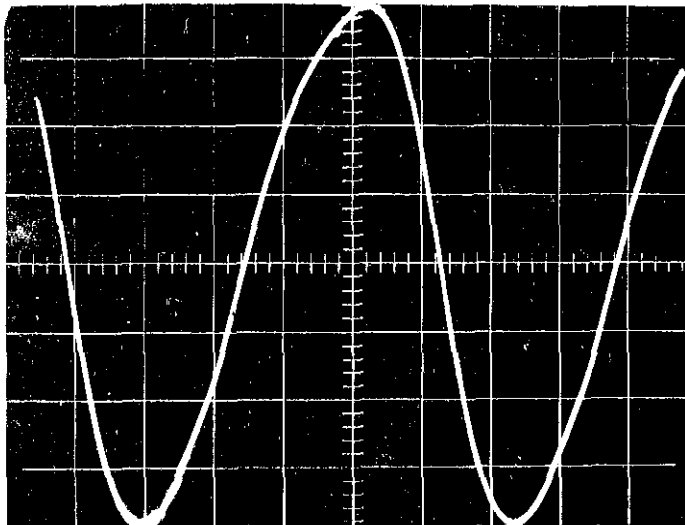

FIGURE 25. Correct Wave Form at Point F (Figure 30) in Oscillator Circuit. Scale is 2 v/cm vertical, 2 msec/cm horizontal.

If it does not but resembles Figure 26, use a 15-kilohm resistor for R307. Transistors Q22 and Q23 are matched for gain. Order replacements only from Keithley Instruments.

2. Set the oscillator frequency to 94 cps ± 0.1 cps with potentiometer R319 (Figure 37).

3. Set the oscillator signal amplitude to 15.4 volts peak-to-peak ± 0.2 v peak-to-peak, measured on the oscilloscope. Adjust with potentiometer R313 (Figure 37).

4. Check the wave form at point F. It should be essentially sinusoidal, as in Figure 25.

NOTE

If transistors Q21, Q22 or Q23 are replaced, it may be necessary to change resistor R307. A 27-kilohm resistor should provide the proper bias for Q22 and Q23. The wave form at point F should resemble Figure 25.

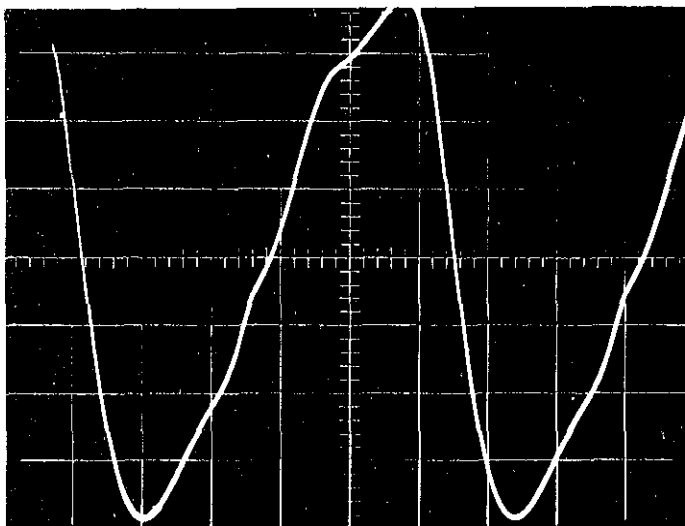

A

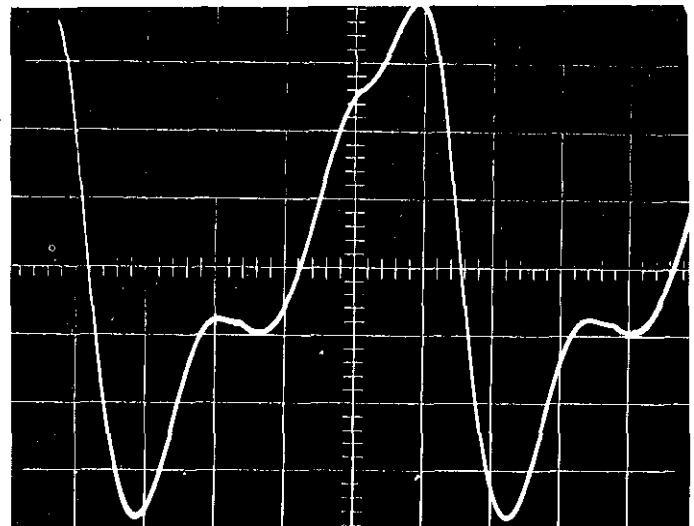

B

FIGURE 26. Improper Wave Forms at Point F (Figure 30) in Oscillator Circuit. Wave A indicates the wrong bias; wave B is distorted. Scale for both is 2 v/cm vertical, 2 msec/cm horizontal.

5-10. AMPLIFIER CHECK OUT AND CALIBRATION.

a. The check out and calibration of the amplifier circuits is divided into two parts: operational check and gain calibration. The operational check does not have to be followed

TROUBLE	PROBABLE CAUSE	SOLUTION
Unable to adjust frequency to 94 cps	Shorted chopper drive circuit	Disconnect chopper at J302. Check for 94 cps at Q19 emitter (Point H, Fig. 29 or 37). Check for shorted wiring and chopper coil.
Distorted, off-frequency wave form at point H (Fig. 29 or 37) with chopper disconnected	Defective Q17, Q18 or Q19	Voltage at point H should be 1 to 2 volts peak-to-peak, sine wave. If not, check components; replace if faulty.
Low voltage, distorted wave form at point F (Fig. 30)	Defective Q17, Q18, Q19 or R322 (Fig. 26B)	Check components; replace if faulty.
	Defective Q20, Q21, Q22, Q23 or R313 (Fig. 26, A or B)	Check the voltage, Q20 to Q23, given on schematic 17353D. Replace faulty components.
	Improper bias to Q22 and Q23 (Fig. 26A)	Adjust R307 as in note.
Unstable frequency	Defective Q17, R319, C301, C302, C303 or R321, R320, R303, R318	Check components; replace if faulty. Q17 or R319 are most likely parts.

TABLE 11. Oscillator Circuit Troubleshooting Table.

by gain calibration. Use this to check the Model 147 operation. If the amplifiers fail to check out at any point, refer to Table 13. After clearing the trouble, continue the check.

NOTE

Check the power supply and oscillator circuits before adjusting the amplifiers. If the other two circuits are changed, the amplifier circuit may need recalibration.

b. Operational Check Procedures.

1. Connect the Model 1488 Shorting Plug to the INPUT. Set the front panel controls as follows:

POWER SUPPLY Switch	BATTERY
RANGE Switch	0.3
FUNCTION Switch	MICROVOLTS
ZERO SUPPRESS COARSE Control	OFF
ZERO SUPPRESS FINE Control	At one end of rotation

2. On the 0.3-microvolt range, the meter offset should be less than 0.2 microvolt (66% of full scale). It may be higher if the Shorting Plug is not used.

3. Connect the Model 260 to the Model 147 INPUT Receptacle with the Model 2603 Input Cable. Adjust the Model 260 for 100-nanovolt output.

NOTE

Follow the operating instructions in the Model 260 Instruction Manual. Closing the input compartment, making good connections and similar details are very important in the nanovolt and microvolt regions.

4. Connect the oscilloscope to the Model 147 OUTPUT. Set the oscilloscope amplifier to dc coupling, 0.2 volt/cm, time base to 0.1 or 0.2 second/cm. Set the Model 147 to the 0.1-microvolt range. Turn the Model 260 POLARITY Switch to OFF. Set the ZERO SUPPRESS Controls to compensate for residual thermal emf's. Turn the Model 260 POLARITY Switch to + or -; observe the wave form on the oscilloscope. The response time (from 10% to 90% of final value) should be between 0.9 and 1.0 second. Cautiously adjust potentiometer R109 (Figure 34) for this value.

NOTE

Potentiometer R109 is a critical control. It adjusts the amplifier gain which affects output ripple, input resistance and maximum source resistance as well as response time. Adjust this control only if one of these characteristics is slightly out of specifications.

c. Gain Calibration Procedures.

1. Connect the Model 260 to the Model 147 INPUT with the Model 2603 Input Cable.
2. Connect the Model 660A Differential Voltmeter to the Model 147 OUTPUT Receptacle.
3. Before turning the Model 260 POLARITY Switch to + or -, adjust the ZERO SUPPRESS Controls for zero output at the output terminals. Use the Model 660A to indicate the zero output. Set the Model 660A to its most sensitive range.
4. For a given full-scale input signal, measure the output voltage. It should be 1 volt dc $\pm 1\%$ for all ranges.
5. After calibrating the amplifier, adjust the input voltage (or zero suppression) for full-scale outputs as shown on the Model 660A, on any range 1 microvolt and above. Adjust potentiometer R136 (Figure 34) for exactly full-scale meter deflection.
6. Check the ranges in Table 12. The Table indicates which range resistor would be faulty if any range is not correct. If these ranges check out, all ranges are within specifications. If a range fails to check, refer to Table 13. Re-zero using the Zero Suppress Controls before each check.

5-11. ZERO SHIFT BY SOURCE RESISTANCE.

a. Potentiometer R239 (Figure 29) adjusts the current fed back to the feedback point. The current compensates for abnormal shifts in the meter zero as the source resistance changes. At manufacture, the current is set to allow the least shift over a range of resistances from near zero to 10 kilohms. The potentiometer can also be adjusted to permit no zero shift for a given source resistance if this is desired.

b. Adjust potentiometer R239 by measuring the zero shift in the Model 147 meter as the source resistance is changed for a given source voltage. Before adjusting the control, make sure low thermal construction is used in building and connecting the source resistances. For most purposes, it is better to return the Model 147 to the factory for this adjustment.

5-12. **AMPLIFIER PHASE CHECK.** Connect the oscilloscope to the DEMODULATOR TEST Jack on the rear panel. Turn the ZERO SUPPRESS COARSE Control to 3; turn the FINE Control away from the end point until the oscilloscope indicates that the amplifier is not saturated (the wave form is not clipped at either end). The wave form should appear as a half-wave rectified sine wave, positive or negative. See Figure 27. It should not appear out of phase as in Figure 28. Low frequency modulation and some bounce off the envelope of the signal is normal.

Range	Resistor Used In RANGE Switch
100 Millivolts and all other ranges	R137B, R139, R144
0.03 and 0.3 millivolt	R149, R150
0.1 Millivolt	R170
0.3 Millivolt	R171
1 Millivolt	R145
3 Millivolts	R146
10 Millivolgs	R147
30 Millivolts	R148
100 Millivolts and 100 Microvolts	R137 ratio

TABLE 12. Range Checkout. If these ranges are correct, all Model 147 ranges are correct. If any fail, check the listed resistor.

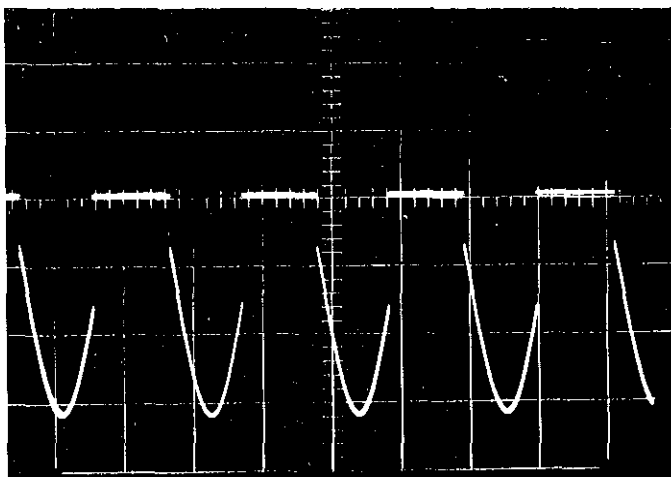

FIGURE 27. Correct Wave Form at DEMODULATOR TEST Jack. See paragraph 5-12. Scale is 1 v/cm vertical, 5 msec/cm horizontal.

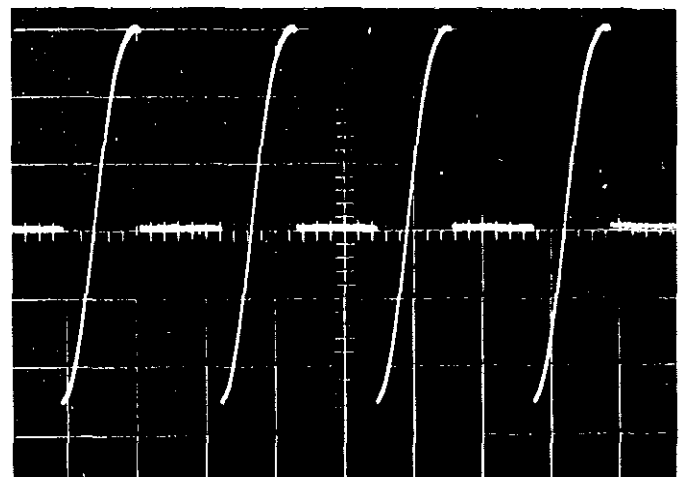

FIGURE 28. Out-of-Phase Wave Form at DEMODULATOR TEST Jack. See paragraph 5-12. Scale is 1 v/cm vertical, 5 msec/cm horizontal.

TROUBLE	PROBABLE CAUSE	SOLUTION
High zero offset	Short in feedback network.	Make sure lugs do not touch each other or the copper plate in input compartment. Check resistances.
	Maladjusted degaussing coil	Adjust (paragraph 5-4).
Random zero drift, tens of nanovolts or more; sometimes reduced if the cabinet slapped. Response speed is good.	Noisy chopper	Replace chopper; see paragraph 5-4.
Zero drift greatly affected by slight movement of FUNCTION Switch within a setting.	Maladjusted or dirty FUNCTION Switch.	Loosen set screws on rotor hub (Figure 30); slide rotor away from pins. Clean rotor and pins with non-metallic abrasive. Adjust so the rotor is flush with and makes contact with all 3 pins consecutively, two at a time.
Abnormal zero shift as source resistance changes.	Potentiometer R239 is out of adjustment.	Adjust (paragraph 5-11).
Zero drift affected greatly by temperature changes.	Contaminated INPUT Receptacle, shorting plug, or connection in input compartment.	Clean INPUT Receptacle with non-metallic abrasive. If contamination goes below plated surface, replace receptacle. Clean lugs with non-metallic abrasive; be sure to return leads to posts in original order.
Demodulator does not "clamp" during one-half cycle (Fig. 27).	Defective Q9, Q10, Q24 or Q25.	Check for sine wave at secondary of T302, square wave at collector Q24 and Q25 and base Q9 and Q10. Replace faulty components.
Greater than 20-mv peak-to-peak ripple at output terminals on ac power. On battery operation, output ripple is above 5 mv p-p.	Instrument located near high 180-cps magnetic field, such as poorly shielded heavy-duty transformer.	Try turning off possible sources one by one. Move instrument from field source.

TABLE 13 (Sheet 1). Amplifier Troubleshooting Table.

TROUBLE	PROBABLE CAUSE	SOLUTION
Response speed very slow, possibly zero offset also high. Cannot adjust to specifications with R109.	Low ac amplifier gain, due to bad active element.	Set to 0.1- μ v range, ZERO SUPPRESS COARSE to 3, FINE to an easily readable signal. With oscilloscope, check for square wave at V1 grid, and sine wave at input and output of each succeeding stage. Check dc voltages, V1 through Q8, given on schematic 18512F. Replace faulty components.
	Improper amplifier phasing.	See paragraph 5-11. If waveform is incorrect, use lissajous patterns to check phase from grid V1 through each stage to base Q7. Shifts of up to about 30° are acceptable. Check capacitors and active elements.
	Low gain in dc amplifier.	Unsolder and lift one end of R123 and R124. See points M and N, Figure 34. Apply 10 to 100 mv to base of Q11 to zero meter. Change input by 1 millivolt; output should shift 0.3 to 3.0 volts. If not, or if more than 100 mv is required to zero, check transistors, beginning with Q11 and Q12. Q11 and Q12 are matched for offset. Replace only with parts purchased from Keithley.
	Leaky or shorted C115.	Check; replace if faulty.
100-millivolt and all other ranges out of calibration, all same direction.	R144, R139, or R137 out of tolerance.	Check resistors; replace if faulty.
Only 0.03-microvolt or millivolt ranges out of calibration.	R149 or R150 out of tolerance.	Check resistors; replace if faulty.
All microvolt ranges out of calibration. The millivolt ranges are good.	R137 ratio B to A, out of tolerance.	Check resistor; replace if faulty.
One range out of calibration.	Corresponding resistor in Table 12 out of tolerance.	Check resistor; replace if faulty.

TABLE 13 (Sheet 2). Amplifier Troubleshooting Table.

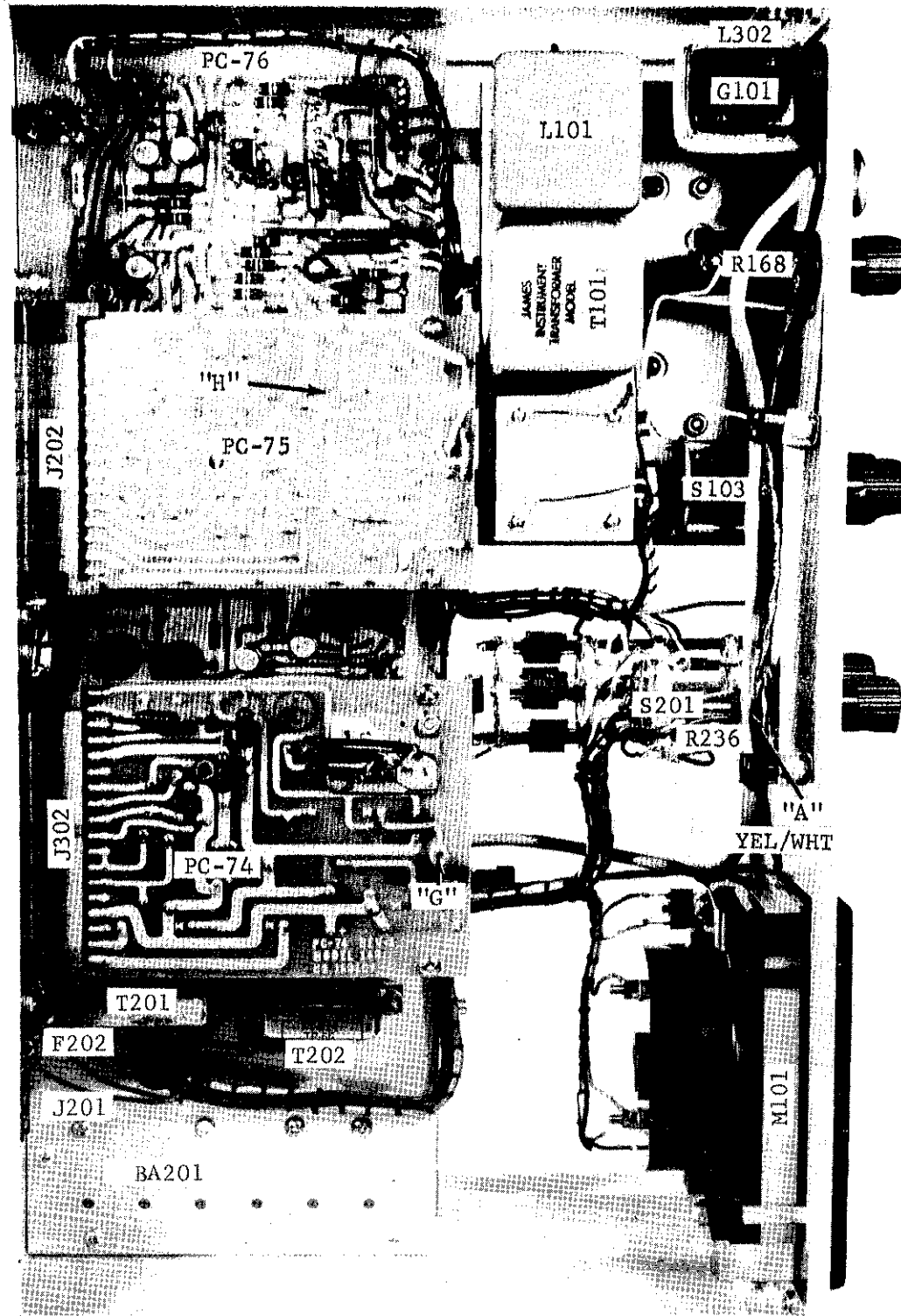

FIGURE 29. Top View of Model 147 Chassis. Locations of components, printed circuits and some test points are shown above. Refer to Parts List for circuit designations. R237 to R241, located on PC 76, are reached between the two printed circuit board modules.

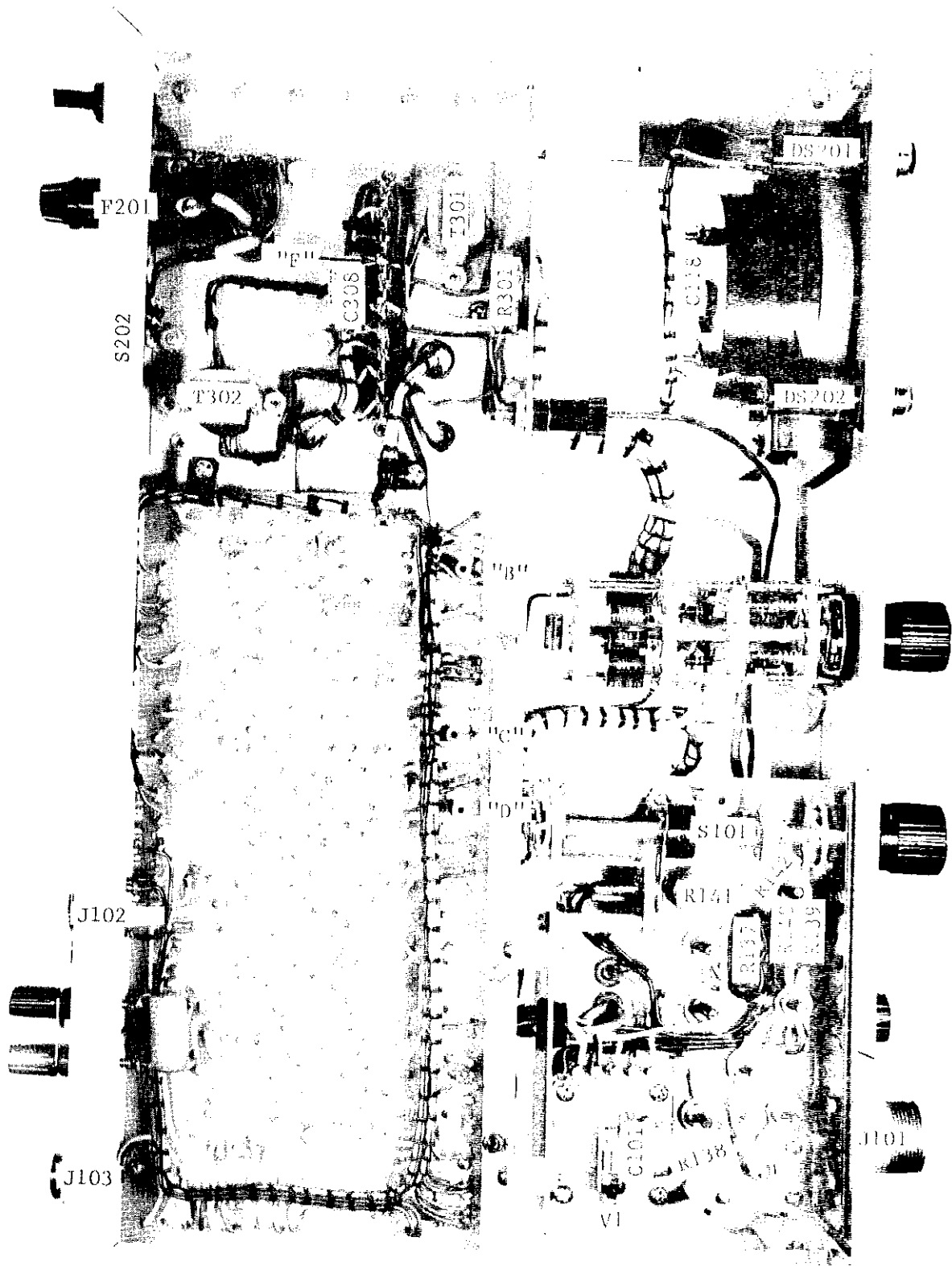

FIGURE 30. Bottom View of Model 147 Chassis. Locations of components and some test points are shown above. The input compartment is shown without its shield. Refer to Parts List for circuit designations.

* Connect to point F at either place, not to both points simultaneously.

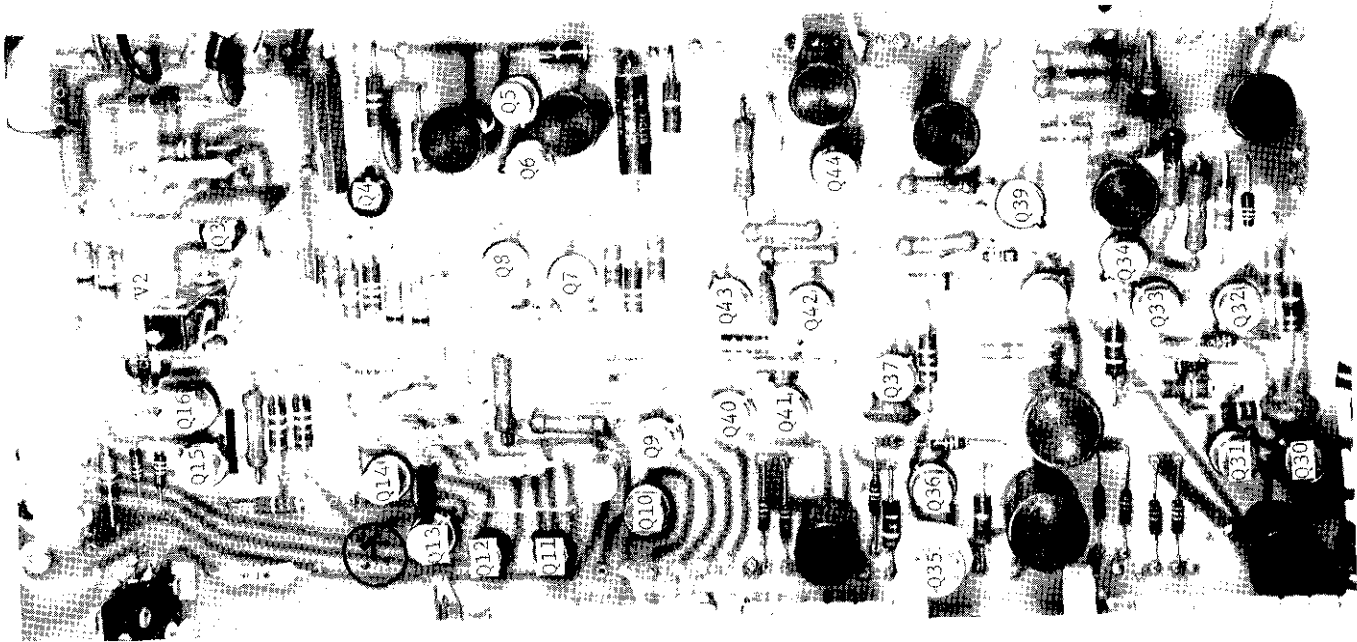

FIGURE 31. Transistor Locations on Printed Circuit 76.

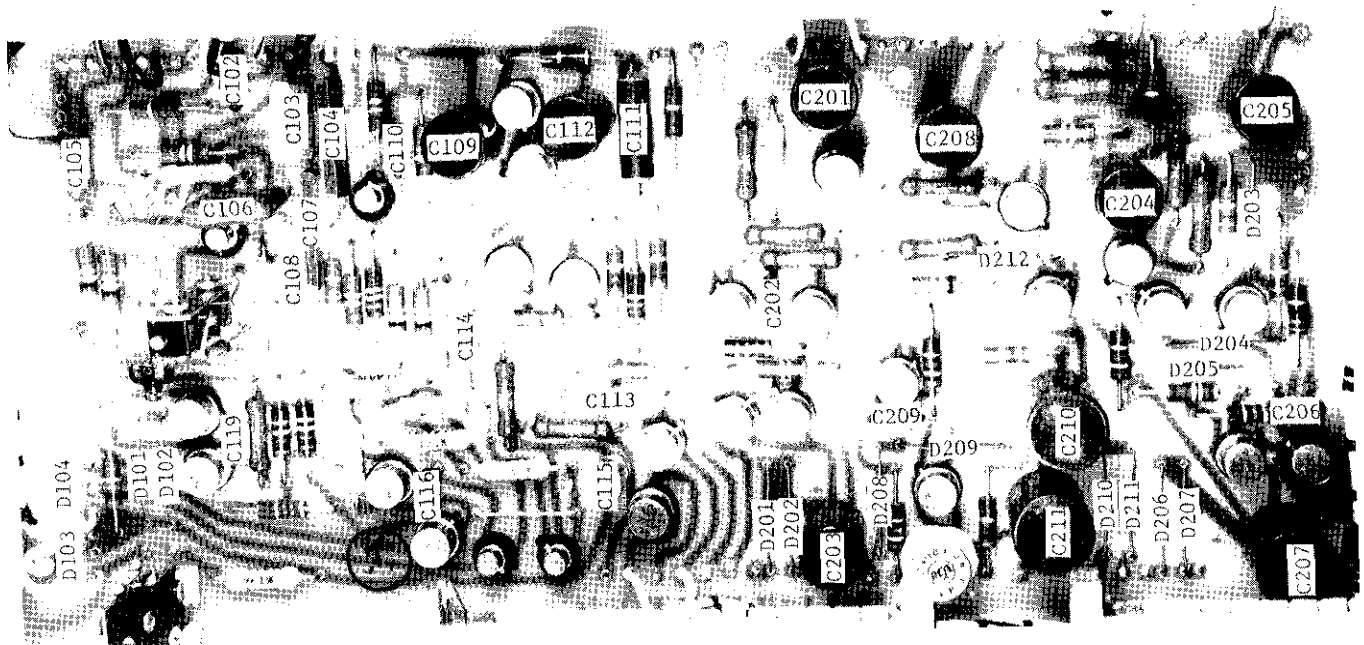

FIGURE 32. Capacitor and Diode Locations on Printed Circuit 76.

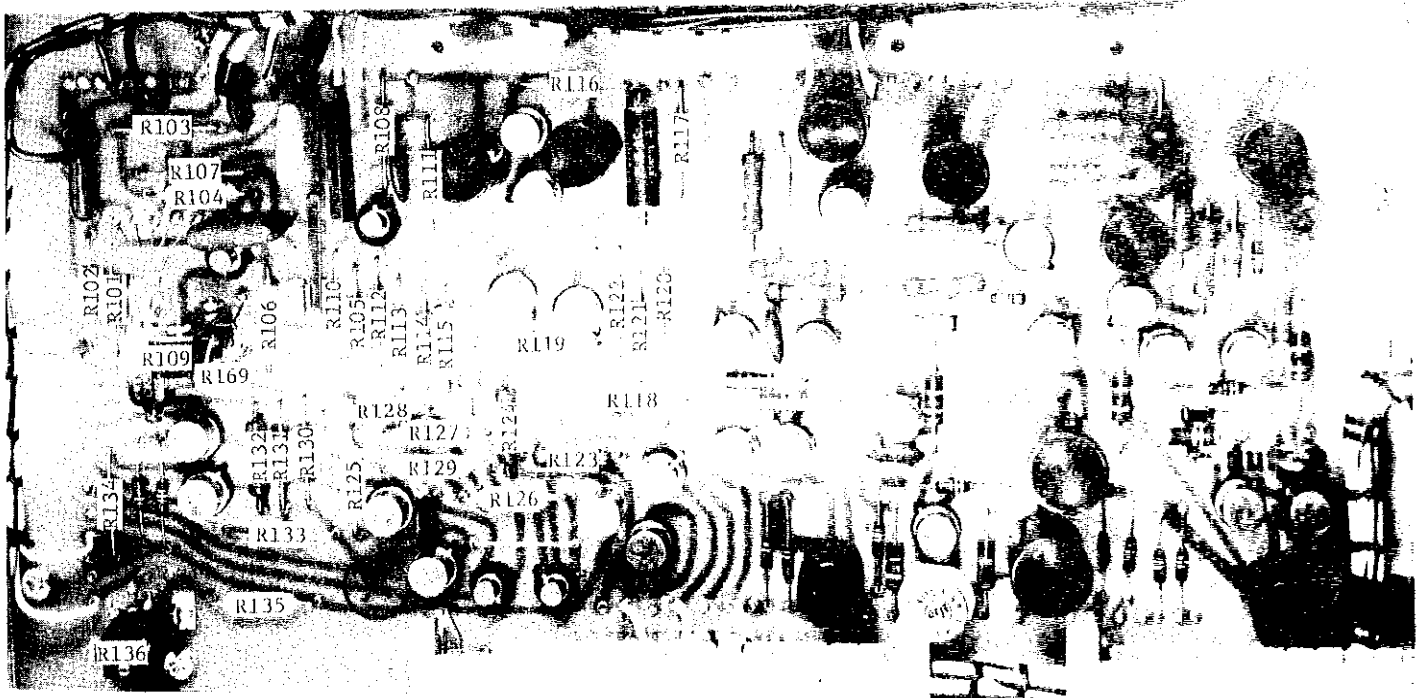

FIGURE 33. Resistor Locations on Printed Circuit 76. Figure 34 contains callouts for the other resistors.

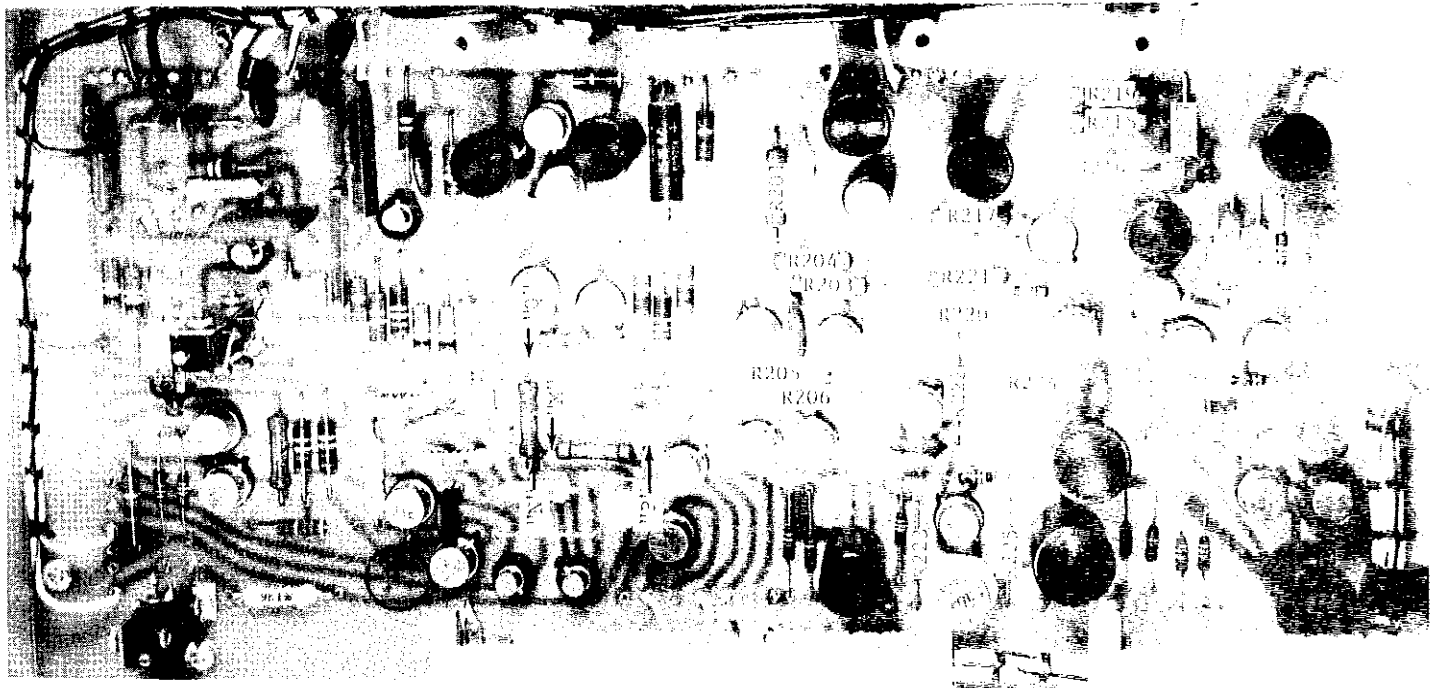

FIGURE 34. Resistor and Test Point Locations on Printed Circuit 76. Figure 33 contains callouts for the other resistors

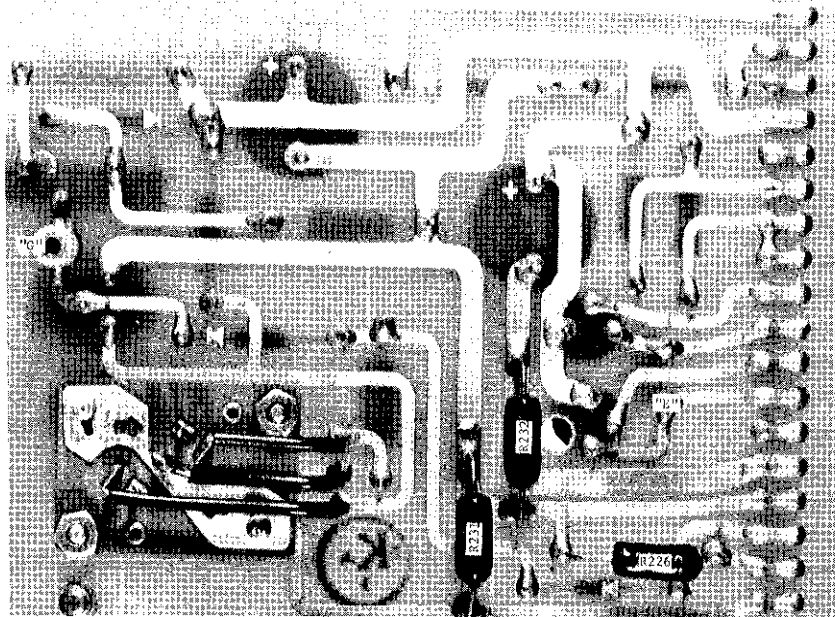

FIGURE 35. Resistor and Test Point Locations on Printed Circuit 74, Bottom Face. Connect to point E at either place, not to both points simultaneously.

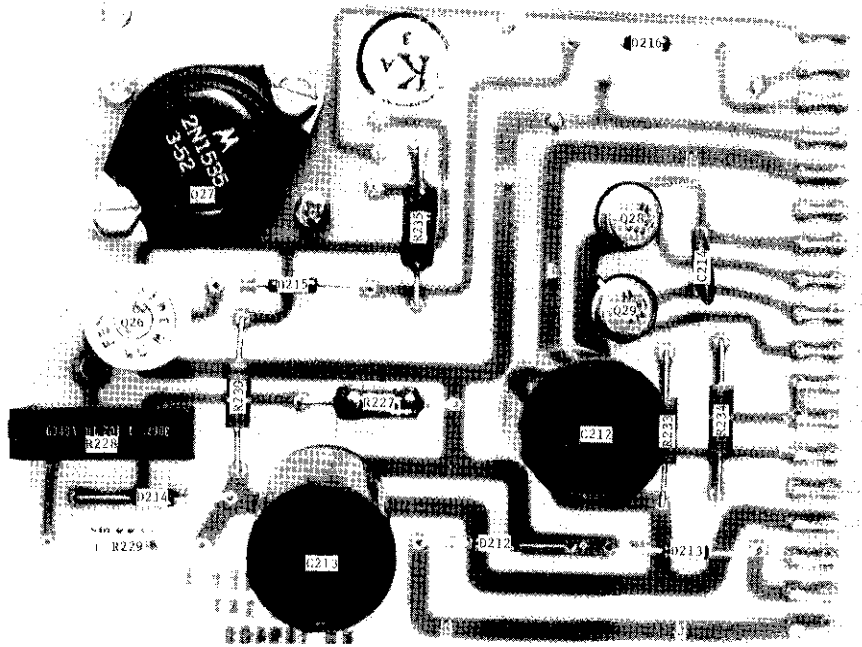

FIGURE 36. Component Locations on Printed Circuit 74, Top Face.

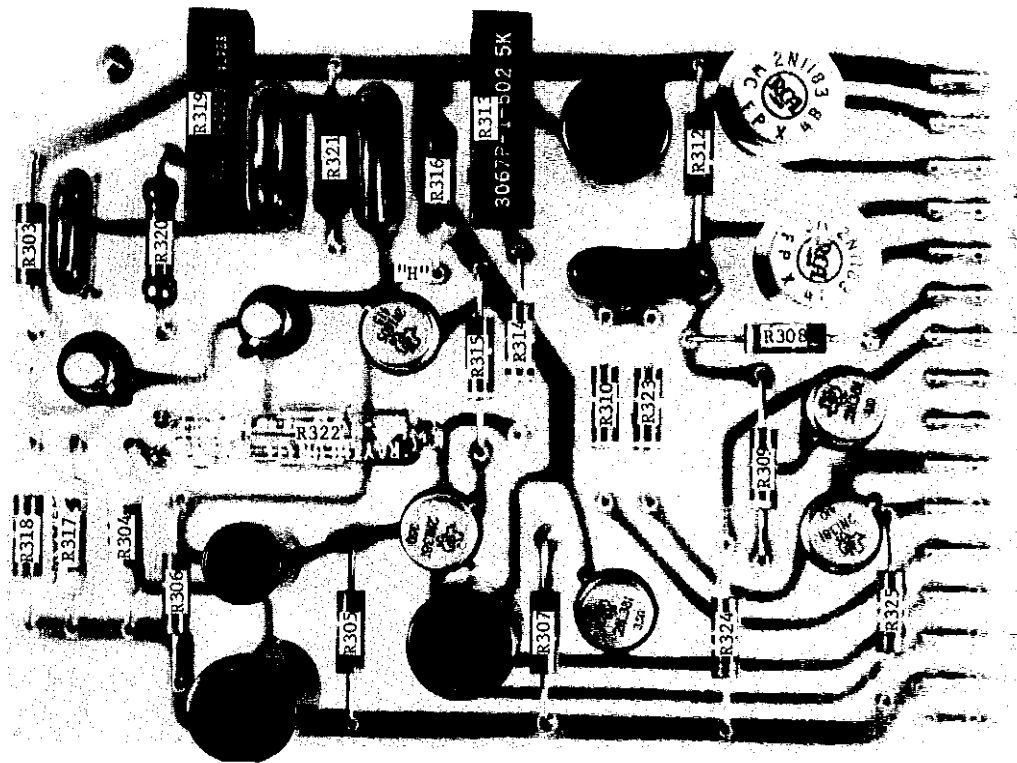

FIGURE 37. Resistor and Test Point Locations on Printed Circuit 75. An alternate location for point H is shown in Figure 29.

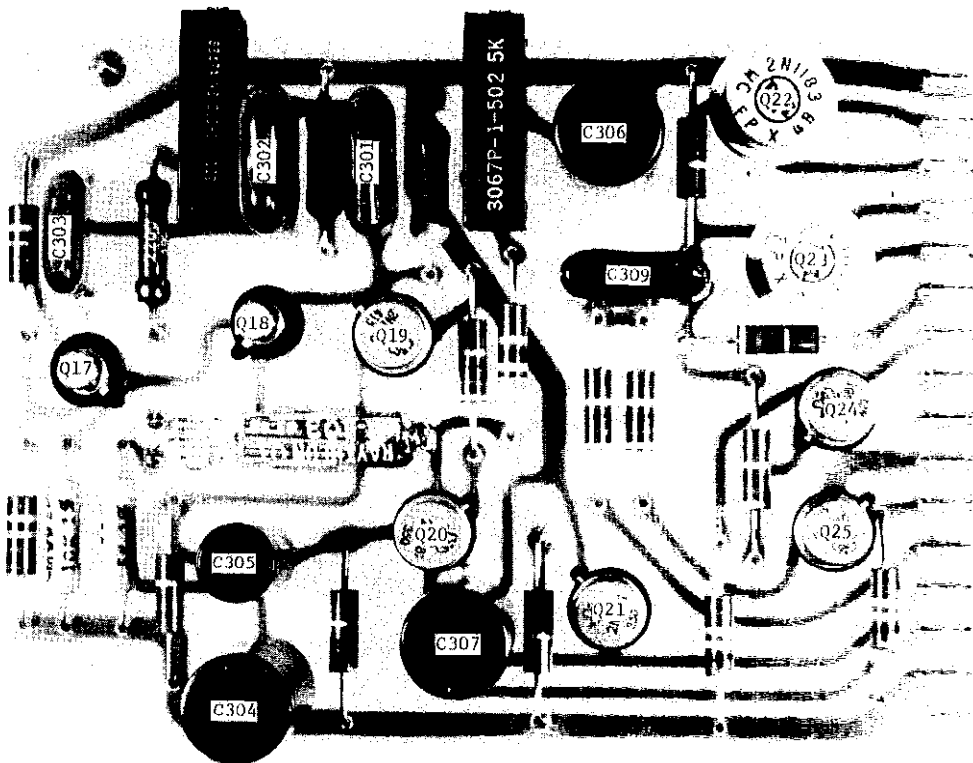

FIGURE 38. Capacitor and Transistor Locations on Printed Circuit 75.

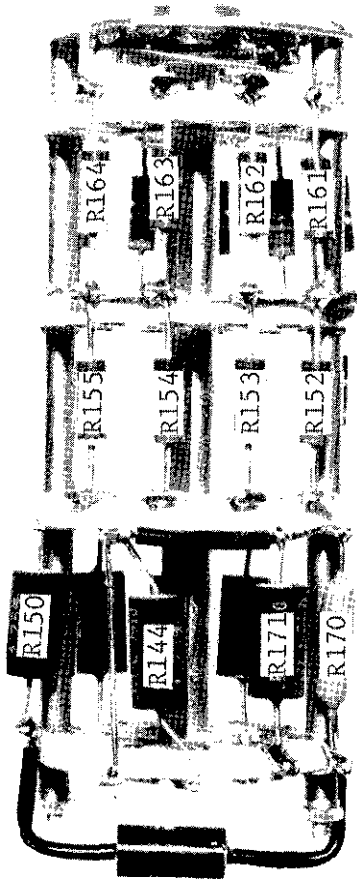

FIGURE 39. Resistor Locations on RANGE Switch (S102). Figure 40 shows resistors on opposite side.

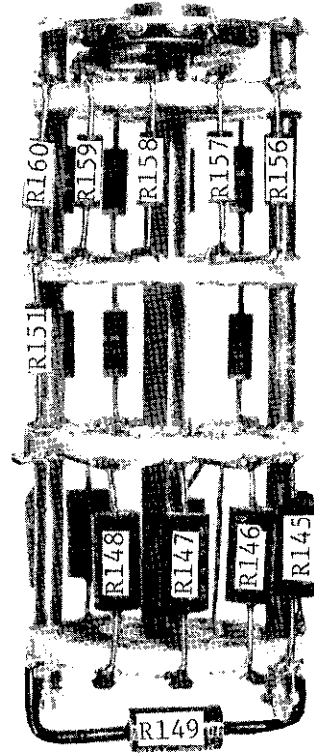

FIGURE 40. Resistor Locations on RANGE Switch (S102). Figure 39 shows resistors on opposite side.

SECTION 6. REPLACEABLE PARTS

6-1. REPLACEABLE PARTS LIST. The Replaceable Parts List describes the components of the Model 147 and its accessories. The List gives the circuit designation, the part description, a suggested manufacturer, the manufacturer's part number and the Keithley Part Number. The last column indicates the figure picturing the part. The name and address of the manufacturers listed in the "Mfg. Code" column are in Table 15.

6-2. HOW TO ORDER PARTS.

a. For parts orders, include the instrument's model and serial number, the Keithley Part Number, the circuit designation and a description of the part. All structural parts and those parts coded for Keithley manufacture (80164) must be ordered through Keithley Instruments or its representatives. In ordering a part not listed in the Replaceable Parts List, completely describe the part, its function and its location.

b. Order parts through your nearest Keithley representative or the Sales Service Department, Keithley Instruments, Inc.

amp	ampere	Mfg.	Manufacturer
CbVar	Carbon Variable	MtF	Metal Film
CerD	Ceramic, Disc	Mil. No.	Military Type Number
Comp	Composition	My	Mylar
DCb	Deposited Carbon	Ω	ohm
EAL	Electrolytic, Aluminum	PMF	Metalized paper, phenolic case
EMC	Electrolytic, metal cased	Poly	Polystyrene
ETB	Electrolytic, tubular	p	pico (10^{-12})
ETT	Electrolytic, tantulum	Ref.	Reference
F	farad	μ	micro (10^{-6})
Fig.	Figure	v	volt
hy	henry	Var	Variable
k	kilo (10^3)	w	watt
M or meg	mega (10^6) or megohms	WW	Wirewound
m	milli (10^{-3})	WWenc	Wirewound encapsulated
		WWVar	Wirewound Variable

TABLE 14. Abbreviations and Symbols.

MODEL 147 REPLACEABLE PARTS LIST

(Refer to Schematic Diagrams 18512F, 17352D and 17353D for circuit designations)

CAPACITORS

Circuit Desig.	Value	Rating	Type	Mfg. Code	Mfg. Part No.	Keithley Part No.	Fig. Ref.
C101	.0135 μ F	100 v	Poly	84171	PE-143J	C-45-0.0135M	21
C102	.01 μ F	16 v	CerD	71590	UK16-104	C-238-.01M	32
C103 (60 Hz)	.184 μ F	100 v	My	12673	32M	C-105-.184M	32
C103 (50 Hz)	.109 μ F	100 v	My	12673	32M	C-105-.109M	32
C104 (60 Hz)	.0135 μ F	100 v	Poly	84171	PE-133J	C-45-.0135M	32
C104 (50 Hz)	.0155 μ F	100 v	Poly	84171	PE-153J	C-45-.0155M	32
C105	Not Used						
C106	.22 μ F	50 v	My	84411	601PE	C-41-.22M	32
C107	.012 μ F	100 v	Poly	84171	PE-123J	C-45-.012M	32
C108	4.7 μ F	10 v	ETB	05397	K4R7J10S	C-71-4.7M	32
C109	100 μ F	15 v	EAL	29309	JC-6-100-15-8P	C-210-100M	32
C110	.01 μ F	1000 v	CerD	72982	811Z5V103P	C-22-.01M	32
C111	25 μ F	16 v	EAL	56289	TL1157-1	C-104-25M	32
C112	100 μ F	15 v	EAL	29309	JC-6-100-15-8P	C-210-100M	32
C113	10 μ F	20 v	ETT	05397	K10J20K	C-80-10M	32
C114	10 μ F	20 v	ETT	05397	K10J20K	C-80-10M	32
C115	25 μ F	10 v	ETT	05079	(non-polar)	C-106-25M	32
C116	Not Used						
C117	Not Used						
C118	200 μ F	3 v	ETB	14655	NLW200-3	C-48-200M	30
C119	.047 μ F	20 v	MPF	97419	M2W-R-.047M	C-143-.047M	32
C120	*	500 v	Poly	71590	CPR-XXXJ	C-138-*	
C201	Not Used						
C202	Not Used						
C203	Not Used						
C204	100 μ F	15 v	EAL	29309	JC-6-100-15-8P	C-210-100M	32
C205	100 μ F	15 v	EAL	29309	JC-6-100-15-8P	C-210-100M	32
C206	.01 μ F	1000 v	CerD	72982	811Z5V103P	C-22-.01M	32
C207	100 μ F	25 v	EAL	56289	89D226	C-94-100M	32
C208	100 μ F	15 v	EAL	56289	JC-6-100-15-8P	C-210-100M	32
C209	.01 μ F	1000 v	CerD	72982	811Z5V103P	C-22-.01M	32
C210	100 μ F	25 v	EAL	56289	89D226	C-94-100M	32
C211	100 μ F	25 v	EAL	29309	JC14-500-25-8P	C-94-100M	32
C212	500 μ F	25 v	EAL	29309	JC14-500-25-8P	C-94-500M	36
C213	500 μ F	25 v	EAL	29309	JC14-500-25-8P	C-94-500M	36
C214	.01 μ F	1000 v	CerD	72982	811Z5V103P	C-22-.01M	36
C301	.22 μ F	50 v	My	84411	601PE	C-41-.22M	38
C302	.22 μ F	50 v	My	84411	601PE	C-41-.22M	38
C303	.1 μ F	50 v	My	84411	601PE	C-41-.1M	38
C304	100 μ F	15 v	EAL	29309	JC-6-100-15-8P	C-210-100M	38
C305	10 μ F	15 v	EAL	56289	89D159	C-93-10M	38

CAPACITORS (Cont'd)

Circuit Desig.	Value	Rating	Type	Mfg. Code	Mfg. Part No.	Keithley Part No.	Fig. Ref.
C306	100 μ F	15 v	EAl	29309	JC-6-100-15-8P	C-210-100M	38
C307	100 μ F	15 v	EAl	29309	JC-6-100-15-8P	C-210-100M	38
C308	2 μ F	50 v	MPCb	14752	625B1A205	C-215-2M	30
C309	.22 μ F	50 v	My	84411	601PE	C-41-.22M	38
C310	470 pF	1000 v	CerD	71590	DD471	C-64-470P	--
C311	470 pF	1000 v	CerD	71590	DD471	C-64-470P	--

DIODES

Circuit Desig.	Type	Number	Mfg. Code	Keithley Part No.	Fig. Ref.
D101	Silicon	1N645	01295	RF-14	32
D102	Silicon	1N645	01295	RF-14	32
D103	Zener	1N709	12954	DZ-21	32
D104	Zener	1N709	12954	DZ-21	32
D201	Not Used				
D202	Not Used				
D203	Silicon	1N645	01295	RF-14	32
D204	Silicon	1N645	01295	RF-14	32
D205	Zener	Special	80164	DZ-13	32
D206	Silicon	1N645	01295	RF-14	32
D207	Silicon	1N645	01295	RF-14	32
D208	Zener, 2.6V	1N702A	01295	DZ-33	32
D209	Not Used				
D210	Silicon	1N645	01295	RF-14	32
D211	Silicon	1N645	01295	RF-14	32
D212**	Silicon	1N645	01295	RF-14	32
D212***	Silicon	1N645	01295	RF-14	36
D213	Silicon	1N645	01295	RF-14	36
D214	Zener	1N713	12954	DZ-14	36
D215	Silicon	1N645	01295	RF-14	36
D216	Silicon	1N645	01295	RF-14	36

MISCELLANEOUS PARTS

Circuit Desig.	Description	Mfg. Code	Keithley Part No.	Fig. Ref.
BA201	Battery Pack Assembly, 6-volt 4-amp-hr nickel-cadmium	80164	Model 1489	29
DS201	Bulb, AC CONNECTED, bayonet base (Mfg. No. 49)	08804	PL-23	2
---	Pilot Light Assembly, Red (Mfg. No. 81410-231)	72619	PL-5R	2

** Schematic Diagram 18512F

***Schematic Diagram 17352D

MISCELLANEOUS PARTS (Cont'd)

Circuit Desig.	Description	Mfg. Code	Keithley Part No.	Fig. Ref.
DS202	Bulb, BATTERY CHARGING, bayonet base (Mfg. No. 49)	08804	PL-23	2
---	Pilot Light Assembly, Amber (Mfg. No. 81410-233)	72619	PL-5A	
F201(117v)	Fuse, slow blow, 1/8 amp (Mfg. Type MDL)	71400	FU-20	30
F201(234v)	Fuse, slow blow, 1/16 amp (Mfg. Type MDL)	71400	FU-21	30
---	Fuse Holder (Mfg. No. 342012)	75915	FH-3	
F202	Fuse, 1 amp, 8 AG (Mfg. No. 361001)	75915	FU-1	29
---	Fuse Holder	80164	19031A	
G101	Chopper Assembly	80164	17689A	29
J101	Receptacle Assembly, INPUT	80164	17638A- 305912	
---	Plug, Special, Mate of J101	80164	Model 1486	
J102	Phone Jack, DEMODULATOR TEST (Mfg. No. 257)	71002	CS-65	3
--- (F)	Phone Plug, Mate of J102 (Mfg. No. 225)	83330	CS-146	
J103	Receptacle, Microphone, OUTPUT (Mfg. No. 80-PC2F)	02660	CS-32	3
--- (F)	Plug, Microphone, Mate of J103 (Mfg. No. 80-MC2M)	02660	CS-33	
J201	Terminal Block (Mfg. No. 3008)	83330	TE-47	29
J202**	Connector (Mfg. No. PSC4SS-15-11)	09922	CS-238	29
J301**	Connector (Mfg. No. PSC4SS-15-11)	09922	CS-238	29
J302**	Receptacle			
	. Locking Ring (Mfg. No. 126-1430)	02660	CS-165	
	. Receptacle (Mfg. No. 126-1429)	02660	CS-163	
	. Body (Mfg. No. 126-1425)	02660	CS-161	
---	Binding Post, LO (Mfg. No. DF21BC)	58474	BP-11B	3
---	Binding Post, GND (Mfg. No. DF21GC)	58474	BP-11G	3
---	Shorting Link (Mfg. No. 938-L)	24655	BP-6	
L101	Choke, 200 hy	80164	CH-1	29
L102	Choke, 120/80 hy	80164	CH-5	29

(F) Furnished accessory

** Schematic Diagram 18512F

MISCELLANEOUS PARTS (Cont'd)

Circuit Desig.	Description	Mfg. Code	Keithley Part No.	Fig. Ref.
L301	Not Used			
L302	Degaussing Coil	80164	CH-8	29
M101	Meter	80164	ME-14	29
---	Cord Set, 6 feet (Mfg. No. 4638-13)	93656	CO-5	3
---	Cable Clamp (Mfg. No. SR-5P-1)	28520	CC-4	
S101**	Rotary Switch Assembly less components, FUNCTION	80164	SW-161	2
---	Knob Assembly, Function Switch	80164	16323A	
S102	Rotary Switch less components, RANGE	80164	SW-157	2
---	Switch Assembly with components, Range	80164	17632B	
---	Knob Assembly, Range Switch	80164	16323A	
S103	Rotary Switch less components, ZERO SUPPRESS COARSE	80164	SW-58	2
---	Switch Assembly with components, Coarse	80164	17626B	
---	Knob Assembly, Coarse Switch	80164	14838A	
S201	Rotary Switch less components, POWER SUPPLY	80164	SW-158	2
---	Knob Assembly, Power Supply Switch	80164	18393A	
S202	Slide Switch, 117-234 v	80164	SW-151	3
---	Knob Assembly, Fine Control	80164	15110A	2
T101	Transformer Assembly	80164	18435B	29
T201	Transformer	80164	TR-63	29
T202	Transformer	80164	TR-65	29
T301	Transformer	80164	TR-64	30
T302	Transformer	80164	TR-68	30

RESISTORS

Circuit Desig.	Value	Rating	Type	Mfg. Code	Mfg. Part No.	Keithley Part No.	Fig. Ref.
R101	6.8 k Ω	10%, 1/4W	Comp	01121	CB-683-10%	R76-68K	32
R102	10 k Ω	10%, 1/4W	Comp	01121	CB-103-10%	R76-10K	32
R103	4.7 M Ω	10%, 1/2W	Comp	01121	EB-475-10%	R1-4.7M	32
R104	250 k Ω	1%, 1/2 w	DCb	79727	CFE-15	R12-250K	34
R105	22 k Ω	10%, 1/2 w	Comp	01121	EB	R1-22K	33
R106	250 k Ω	1%, 1/2 w	DCb	79727	CFE-15	R12-250K	33
R107	100 k Ω	10%, 1/2 w	Comp	01121	EB	R1-100K	33
R108	22 k Ω	10%, 1/2 w	Comp	01121	EB	R1-22K	33
R109	100 k Ω	20%, .2 w	CbVar	80294	3068S	RP40-100K	34
R110	4.7 k Ω	10%, 1/2 w	Comp	01121	EB	R1-4.7K	34

** If the low-thermal Function Switch needs replacement, return unit for this repair.

RESISTORS (Cont'd)

Circuit Desig.	Value	Rating	Type	Mfg. Code	Mfg. Part No.	Keithley Part No.	Fig. Ref.
R111	22 k Ω	10%, 1/2 w	Comp	01121	EB	R1-22K	33
R112	27 k Ω	10%, 1/2 w	Comp	01121	EB	R1-27K	34
R113	10 k Ω	10%, 1/2 w	Comp	01121	EB	R1-10K	34
R114	10 k Ω	10%, 1/2 w	Comp	01121	EB	R1-10K	34
R115	470 Ω	10%, 1/2 w	Comp	01121	EB	R1-470	33
R116	4.7 k Ω	10%, 1/2 w	Comp	01121	EB	R1-4.7K	33
R117	4.7 k Ω	10%, 1/2 w	Comp	01121	EB	R1-4.7K	33
R118	4.7 k Ω	10%, 1/2 w	Comp	01121	EB	R1-4.7K	33
R119	4.7 k Ω	10%, 1/2 w	Comp	01121	EB	R1-4.7K	33
R120	8.2 k Ω	10%, 1/2 w	Comp	01121	EB	R1-8.2K	33
R121	150 Ω	10%, 1/2 w	Comp	01121	EB	R1-150	34
R122	8.2 k Ω	10%, 1/2 w	Comp	01121	EB	R1-8.2K	33
R123	10 k Ω	1%, 1/2 w	DCb	79727	CFE-15	R12-10K	34
R124	10 k Ω	1%, 1/2 w	DCb	79727	CFE-15	R12-10K	34
R125	50 k Ω	1%, 1/2 w	DCb	79727	CFE-15	R12-50K	34
R126	50 k Ω	1%, 1/2 w	DCb	79727	CFE-15	R12-50K	33
R127	250 Ω	1%, 1/2 w	DCb	79727	CFE-15	R12-250	33
R128	120 k Ω	1%, 1/2 w	DCb	79727	CFE-15	R12-120K	34
R129	120 k Ω	1%, 1/2 w	DCb	79727	CFE-15	R12-120K	34
R130	12 k Ω	10%, 1/2 w	Comp	01121	EB	R1-12K	33
R131	12 k Ω	10%, 1/2 w	Comp	01121	EB	R1-12K	33
R132	25 k Ω	1%, 1/2 w	DCb	79727	CFE-15	R12-25K	34
R133	470 Ω	10%, 1/2 w	Comp	01121	EB	R1-470	33
R134	100 Ω	10%, 1/2 w	Comp	01121	EB	R1-100	33
R135	8.6 k Ω	1%, 1/2 w	DCb	79727	CFE-15	R12-8.6K	34
R136	2 k Ω	10%, 1/2 w	WWVar	80294	3067S	RP35-2K	34
R137A & B	1 k Ω & 1 Ω	Special	WW	80164		17627A	30
R138	10 ⁸ Ω	20%, 1/2 w	Cb	80164		18442A	30
R139	111 Ω	1/4%, 1/3 w	WWenc	80164		17635A	30
R140	1.11 k Ω	1/4%, 1/3 w	WWenc	80164		17636A	30
R141	10 k Ω	5%	WW	80164		R18-19-10K	30
R142	1.02M	1%, 1/2 w	MtF	07716	CEC	R94-1.02M	30
R143	*	1%, 1/2 w	DCb	79727	CFE-15	R12-*	
R144	900 Ω	1/4%, 1/3 w	WWenc	01686	7010	R105-900	39
R145	99 k Ω	1/4%, 1/3 w	WWenc	01686	7010	R105-99K	40
R146	32.3 k Ω	1/4%, 1/3 w	WWenc	01686	7010	R105-32.3K	40
R147	9 k Ω	1/4%, 1/3 w	WWenc	01686	7010	R105-9K	40
R148	2.33 k Ω	1/4%, 1/3 w	WWenc	01686	7010	R105-2.33K	40
R149	900 Ω	1/4%, 1/3 w	WWenc	01686	7010	R105-900	40
R150	100 Ω	1/4%, 1/3 w	WWenc	01686	7010	R105-100	39

* Nominal value, factory set.

RESISTORS (Cont'd)

Circuit Desig.	Value	Rating	Type	Mfg. Code	Mfg. Part No.	Keithley Part No.	Fig. Ref.
R151	3.3 M Ω	10%, 1/2W	Comp	01121	EB	R1-3.3M	40
R152	*1 M Ω	10%, 1/2W	Comp	01121	EB	R1-1M	39
R153	*470 k Ω	10%, 1/2W	Comp	01121	EB	R1-470K	39
R154	*100 k Ω	10%, 1/2W	Comp	01121	EB	R1-100K	39
R155	*27 k Ω	10%, 1/2W	Comp	01121	EB-273-10%	R1-27K	39
R156	Not Used						
R157	330 k Ω	10%, 1/2W	Comp	01121	EB	R1-330K	40
R158	150 k Ω	10%, 1/2W	Comp	01121	EB	R1-150K	40
R159	68 k Ω	10%, 1/2W	Comp	01121	EB	R1-68K	40
R160	22 k Ω	10%, 1/2W	Comp	01121	EB	R1-22K	40
R161	10 k Ω	10%, 1/2W	Comp	01121	EB	R1-10K	39
R162	4.7 k Ω	10%, 1/2W	Comp	01121	EB	R1-4.7K	39
R163	1 k Ω	10%, 1/2W	Comp	01121	EB	R1-1K	39
R164	470 Ω	10%, 1/2W	Comp	01121	EB	R1-470	39
R165	3.3 M Ω	1%, 1/2W	DCb	79727	CFE-15	R12-3.3M	**
R166	1 M Ω	1%, 1/2W	DCb	79727	CFE-15	R12-1M	**
R167	100 k Ω	1%, 1/2W	DCb	79727	CFE-15	R12-100K	**
R168	10 k Ω	3%, 1.5W	WWVar	73138	7216	RP41-10K	29
R169	*	10%, 1/2W	Comp	01121	EB	R1-*	34
R170	1 M Ω	1/2%, 1/2W	MtF	07716	CEC	R61-1M	39
R171	332 k Ω	1/4%, 1/3W	WWenc	01686	7010	R105-332K	39
R172	10 k Ω	1%, 1/2W	DCb	79727	CFE-15	R12-10K	**
R173	15 k Ω	1%, 1/8W	MtF	07716	CEA-TO-15K	R88-15K	32
R174	*	10%, 1/4W	Comp	01121	CB-*	R-76-*	32
R175	*	10%, 1/4W	Comp	01121	CB-*	R-76-*	32
R201	Not Used						
R202	Not Used						
R203	Not Used						
R204	Not Used						
R205	Not Used						
R206	Not Used						
R207	1 k Ω	10%, 1/2W	Comp	01121	EB	R1-1K	33
R208	6.98 k Ω	1%, 1/2W	DCb	79727	CFE-15-6.98K	R12-6.98K	34
R209	6.98 k Ω	1%, 1/2W	DCb	79727	CFE-15-6.98K	R12-6.98K	33
R210	4.7 k Ω	10%, 1/2W	Comp	01121	EB	R1-4.7K	33
R211	2.7 k Ω	10%, 1/2W	Comp	01121	EB	R1-2.7K	33
R212	6.8 k Ω	10%, 1/2W	Comp	01121	EB	R1-6.8K	34
R213	22 Ω	10%, 1/2W	Comp	01121	EB	R1-22	33
R214	2.7 k Ω	10%, 1/2W	Comp	01121	EB	R1-2.7K	34
R215	15 k Ω	10%, 1/2W	Comp	01121	EB	R1-15K	34
R216	22 k Ω	10%, 1/2W	Comp	01121	EB	R1-22K	34
R217	10 k Ω	1%, 1/2W	DCb	79727	CFE-15	R12-10K	34
R218	10 k Ω	1%, 1/2W	DCb	79727	CFE-15	R12-10K	34

* Nominal value, factory set.

** These resistors are located in S103, Figure 29.

RESISTORS (Cont'd)

Circuit Desig.	Value	Rating	Type	Mfg. Code	Mfg. Part No.	Keithley Part No.	Fig. Ref.
R219	4.7 k Ω	1%, 1/2 w	DCb	79727	CFE-15	R12-4.7K	33
R220	10 k Ω	10%, 1/2 w	Comp	01121	EB	R1-10K	33
R221	10 k Ω	1%, 1/2 w	DCb	79727	CFE-15	R12-10K	34
R222	2.7 k Ω	10%, 1/2 w	Comp	01121	EB	R1-2.7K	34
R223	2.7 Ω	10%, 1/2 w	Comp	01121	EB	R1-2.7	33
R224	4.7 k Ω	10%, 1/2 w	Comp	01121	EB	R1-4.7K	34
R225	1 k Ω	10%, 1/2 w	Comp	01121	EB	R1-1K	33
R226	*220 Ω	5%, 3 w	WW	44655	4400	R92-220	35
R227	330 Ω	5%, 3 w	WW	44655	4400	R92-330	36
R228	1 k Ω	10%, 1/2 w	WWVar	80294	3067S	RP39-1K	36
R229	1.8 k Ω	1%, 1/2 w	DCb	79727	CFE-15	R12-1.8K	36
R230	680 Ω	10%, 1/2 w	Comp	01121	EB	R1-680	36
R231	10 Ω	5%, 3 w	WW	44655	4400	R92-10	35
R232	18 Ω	5%, 3 w	WW	44655	4400	R92-18	35
R233	100 Ω	10%, 1/2 w	Comp	01121	EB	R1-100	36
R234	1.5 k Ω	10%, 1/2 w	Comp	01121	EB	R1-1.5K	36
R235	1 Ω	5%, 3 w	WW	44655	4400	R92-1	36
R236	75 k Ω	1%, 1/2 w	DCb	79727	CFE-15	R12-75K	29
R237	1 k Ω	10%, 1/2 w	Comp	01121	EB	R1-1K	29
R238	1 k Ω	10%, 1/2 w	Comp	01121	EB	R1-1K	29
R239	10 k Ω	10%, 1/2 w	WWVar	80294	3067S	RP35-10K	29
R240	100 k Ω	10%, 1/2 w	Comp	01121	EB	R1-100K	29
R241	100 k Ω	10%, 1/2 w	Comp	01121	EB	R1-100K	29
R301	2 Ω	10%, 5 w	WWVar	71450	AW	RP34-2	30
R302	*0 Ω	10%, 1/2 w	Comp	01121	EB	R1-0	--
R303	12 k Ω	10%, 1/2 w	Comp	01121	EB	R1-12K	37
R304	5 k Ω	1%, 1/2 w	DCb	79727	CFE-15	R12-5K	37
R305	4.7 k Ω	10%, 1/2 w	Comp	01121	EB	R1-4.7K	37
R306	8.2 k Ω	10%, 1/2 w	Comp	01121	EB	R1-8.2K	37
R307	*15 k Ω	10%, 1/2 w	Comp	01121	EB	R1-15K	37
R308	4.7 k Ω	10%, 1/2 w	Comp	01121	EB	R1-4.7K	37
R309	4.7 k Ω	10%, 1/2 w	Comp	01121	EB	R1-4.7K	37
R310	4.7 k Ω	10%, 1/2 w	Comp	01121	EB	R1-4.7K	37
R311	Not Used						
R312	10 Ω	10%, 1/2 w	Comp	01121	EB	R1-10	37
R313	5 k Ω	10%, 1/2 w	WWVar	80294	3067S	RP39-5K	37
R314	6.8 k Ω	10%, 1/2 w	Comp	01121	EB	R1-6.8K	37
R315	4.7 k Ω	10%, 1/2 w	Comp	01121	EB	R1-4.7K	37
R316	2.5 k Ω	1%, 1/2 w	DCb	79727	CFE-15	R12-2.5K	37
R317	10 k Ω	1%, 1/2 w	DCb	79727	CFE-15	R12-10K	37
R318	12 k Ω	10%, 1/2 w	Comp	01121	EB	R1-12K	37

* Nominal value, factory set.

RESISTORS (Cont'd)

Circuit Desig.	Value	Rating	Type	Mfg. Code	Mfg. Part No.	Keithley Part No.	Fig. Ref.
R319	2 k Ω	10%, 1/2 w	WWVar	80294	3067S	RP39-2K	37
R320	2.2 k Ω	1%, 1/2 w	DCb	79727	CFE-15	R12-2.2K	37
R321	4 k Ω	1%, 1/2 w	DCb	79727	CFE-15	R12-4K	37
R322	Special (lamp)		Special	80164		PL-32	37
R323	4.7 k Ω	10%, 1/2 w	Comp	01121	EB	R1-4.7K	37
R324	10 k Ω	10%, 1/2 w	Comp	01121	EB	R1-10K	37
R325	10 k Ω	10%, 1/2 w	Comp	01121	EB	R1-10K	37

TRANSISTORS

Circuit Desig.	Mfr. Desig.	Mfg. Code	Keithley Part No.	Fig. Ref.
Q1a FET, N-Chan. (DUAL)	SIL	E411	TG-118	
Q2a FET, N-Chan. (DUAL)	SIL	E411	TG-118	
Q3 NPN, Case TO-106	2N5134	07263	TG-65	31
Q4 NPN, Case TO-106	2N5134	07263	TG-65	31
Q5	2N1381	01295	TG-8	31
NOTE: Q1b and Q2b are not used.				
Q6	2N1381	01295	TG-8	31
Q7	2N1381	01295	TG-8	31
Q8	2N1381	01295	TG-8	31
Q9	2N1381	01295	TG-8	31
Q10	2N1381	01295	TG-8	31
Q11 NPN, Case TO-106	2N5134	07263	TG-65	31
Q12 NPN, Case TO-106	2N5134	07263	TG-65	31
Q13	2N1381	01295	TG-8	31
Q14	2N1381	01295	TG-8	31
Q15	2N1605A	02735	TG-16	31
Q16	2N651	04713	TG-9	31
Q17 NPN, Case TO-106	2N5134	07263	TG-65	38
Q18 NPN, Case TO-106	2N5134	07263	TG-65	38
Q19	2N1605	93332	TG-22	38
Q20	2N1381	01295	TG-8	38
Q21	2N1381	01295	TG-8	38
Q22	2N1381	01295	TG-8	38
Q23	2N1381	01295	TG-8	38
Q24	2N1381	01295	TG-8	38
Q25	2N1381	01295	TG-8	38
Q26	2N1183	02735	TG-11	36
Q27	2N1535	04713	TG-7	36
Q28	2N651	04713	TG-9	36
Q29	2N651	04713	TG-9	36
Q30	2N1381	01295	TG-8	31

TRANSISTORS (Cont'd)

Circuit Desig.	Number	Mfg. Code	Keithley Part No.	Fig. Ref.
Q31	2N1381	01295	TG-8	31
Q32	2N1381	01295	TG-8	31
Q33	2N1381	01295	TG-8	31
Q34	2N1381	01295	TG-8	31
Q35 PNP, Case TO-5	40319	02735	TG-50	31
Q36	2N1381	01295	TG-8	31
Q37	2N1381	01295	TG-8	31
Q38	2N1381	01295	TG-8	31
Q39	2N1381	01295	TG-8	31
Q40 Not Used				
Q41 Not Used				
Q42 Not Used				
Q43 Not Used				
Q44 Not Used				

VACUUM TUBES

Circuit Desig.	Number	Mfg. Code	Keithley Part No.	Fig. Ref.
V1 Not Used				
V2 Not Used				

MODEL 1481 REPLACEABLE PARTS LIST (F)

Description	Mfg. Code	Keithley Part No.
Plug Assembly	80164	Model 1486
Cable Assembly, 48 inches	80164	14731B
Copper Alligator Clips (2) (Mfg. No. 6005)	76545	AC-9

MODEL 1482 REPLACEABLE PARTS LIST

Description	Mfg. Code	Keithley Part No.
Plug Assembly	80164	Model 1486
Cable Assembly, 48 inches	80164	14731B

(F) Furnished accessory

MODELS 1483, 1484 REPLACEABLE PARTS LIST

Description	Quantity	Mfg. Code	Keithley Part No.	Used on Kit Model
Crimp Tool for Copper lugs	1	80164	TL-1	1483
#8 Nylon Screws	50	80164	—	1483, 1484
#8 Nylon Hex Nuts	50	80164	—	1483, 1484
Copper Bolt-on Lugs	100	80164	17340A	1483, 1484
Copper Spade Lugs	100	80164	17339A	1483, 1484
Copper Hook Lugs	100	80164	17336A	1483, 1484
Copper Splice Tubes	100	80164	17338A	1483, 1484
Low-Thermal Cadmium-Tin Solder	10 feet	80164	—	1483, 1484
Copper Alligator Clips (Mfg. No. 6005)	10	76545	AC-9	1483, 1484
Shielded Cable	10 feet	80164	SC-5	1483, 1484
Insulated #20 Copper Wire	100 feet	80164	WS-1	1483, 1484
Non-metallic Abrasive	3 pads	80164	17774A	1483, 1484

01121	Allen-Bradley Corp. Milwaukee, Wis.	08804	Lamp Metals and Components Department G. E. Co. Cleveland, Ohio
01295	Texas Instruments, Inc. Semi Conductor-Components Division Dallas, Tex.	12673	Wesco Division of Atlee Corp. Greenfield, Mass.
01686	RCL Electronics, Inc. Riverside, N. J.	12954	Dickson Electronics Corp. Scottsdale, Ariz.
02660	Amphenol-Borg Electronics Corp. Broadview, Chicago, Illinois	13050	Potter Co. Wesson, Miss.
02735	Radio Corp. of America Commercial Receiving Tube and Semiconductor Division Somerville, N. J.	14655	Cornell-Dubilier Electric Corp. Newark, N. J.
04713	Motorola, Inc. Semiconductor Products Division Phoenix, Arizona	15909	Daven Division Thomas A. Edison Industries McGraw Edison Co., Livingston, N. J.
05079	Tansitor Electronics, Inc. Bennington, Vt.	24655	General Radio Co. West Concord, Mass.
05397	Union Carbide Corp. Linde Division Kemet Dept. Cleveland, Ohio	28520	Heyman Mfg. Co. Kenilworth, N. J.
07716	International Resistance Co. Burlington, Iowa	44655	Ohmite Mfg. Co. Skokie, Ill.
		56289	Sprague Electric Co. North Adams, Mass.

TABLE 15 (Sheet 1). Code List of Suggested Manufacturers. (Based on Federal Supply Code for Manufacturers, Cataloging Handbook H4-1.)

58474	Superior Electric Co., The Bristol, Conn.	79727	Continental-Wirt Electronics Corp. Philadelphia, Pa.
71002	Birnbach Radio Co., Inc. New York, N. Y.	80164	Keithley Instruments, Inc. Cleveland, Ohio
71400	Bussmann Mfg. Div. of McGraw-Edison Co. St. Louis, Mo.	80294	Bourns Laboratories, Inc. Riverside, Calif.
71450	CTS Corp. Elkhart, Ind.	83125	General Instrument Corp. Capacitor Division Darlington, S. C.
72619	Dialight Corp. Brooklyn, N. Y.	83330	Smith, Herman H., Inc. Brooklyn, N. Y.
72982	Erie Technological Products, Inc. Erie, Pa.	84171	Arco Electronics, Inc. Great Neck, N. Y.
73138	Helipot Division of Beckman Instruments, Inc. Fullerton, Calif.	84411	Good-All Electric Mfg. Co. Ogallala, Nebr.
73445	Amperex Electronic Co. Division of North American Philips Co., Inc. Hicksville, N. Y.	91662	Elco Corp. Willow Grove, Pa.
75042	International Resistance Co. Philadelphia, Pa.	93332	Sylvania Electric Products, Inc. Semiconductor Products Division Woburn, Mass.
75915	Littelfuse, Inc. Des Plaines, Ill.	93656	Electric Cord Co. Caldwell, N. J.
76545	Mueller Electric Co. Cleveland, Ohio		

TABLE 15 (Sheet 2). Code List of Suggested Manufacturers. (Based on Federal Supply Code for Manufacturers, Cataloging Handbook H4-1.)

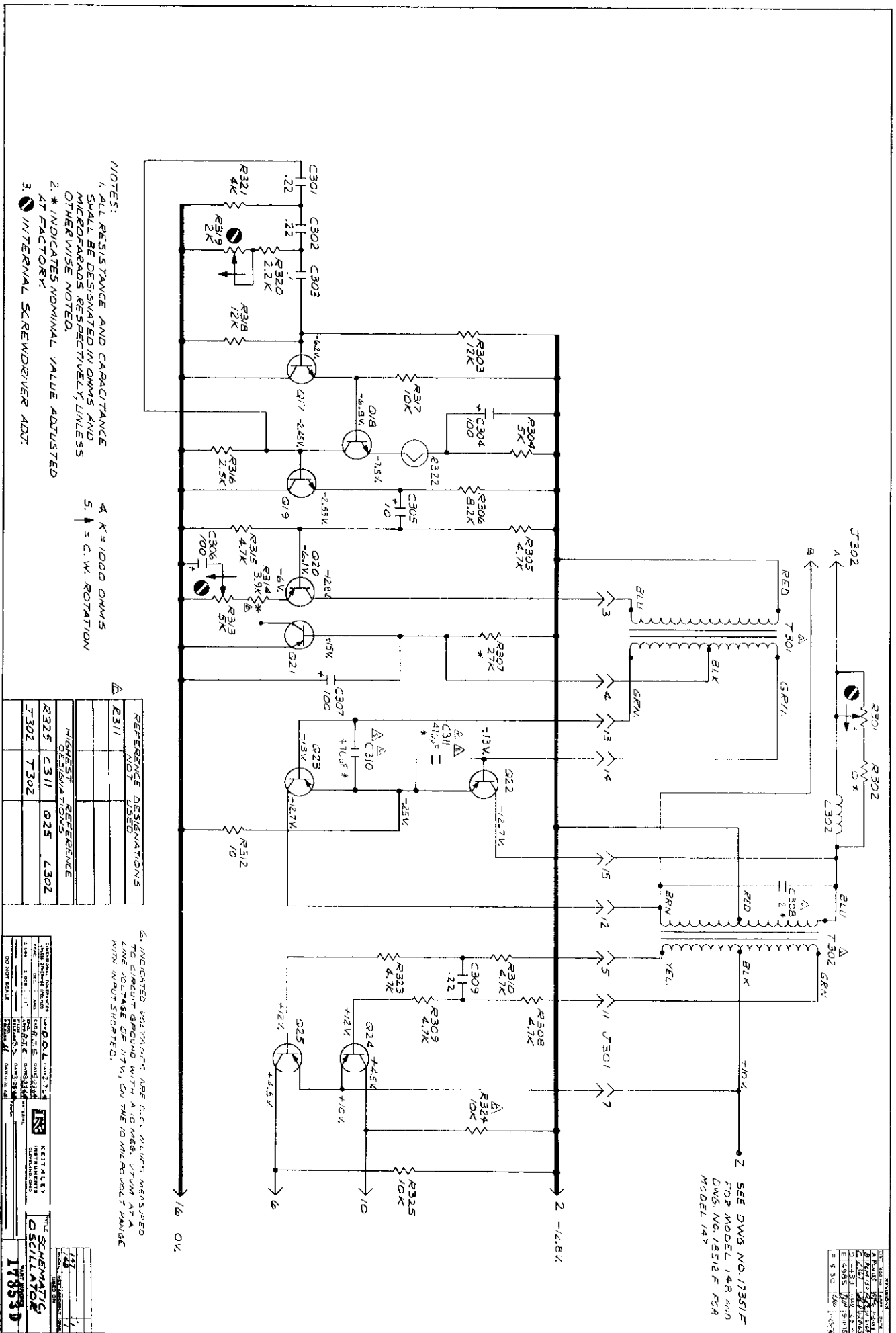

NOTES:
 1. ALL RESISTANCE AND CAPACITANCE SHALL BE DESIGNATED IN OHMS AND MICROFARADS RESPECTIVELY, UNLESS OTHERWISE NOTED.
 2. * INDICATES NOMINAL VALUE ADJUSTED AT FACTORY.
 3. ⚙ INTERNAL SCREWDRIVER ADT.

4. K = 1000 OHMS
 5. ↑ = C.W. ROTATION

REFERENCE DESIGNATIONS NOT USED	HIGHEST REFERENCE DESIGNATIONS
E311	Q25 L302
R325 C311	Q25 L302
J302 T302	

6. INDICATED VOLTAGES ARE D.C. VALUES MEASURED WITH THE METER SET ON D.C. 100V AT A LINE VOLTAGE OF 117V, ON THE 100V RANGE OF THE METER. (PLEASE SEE THE 100V RANGE OF THE METER.)

DOWNSIDE INSTRUMENTS
 MODEL NO. 17853D
 KEITHLEY INSTRUMENTS
 TITLE SCHEMATIC
 OSCILLATOR
 17853D

SEE DWG NO. 17851/F FOR MODEL 148 AND DWG NO. 18512/F FOR MODEL 147

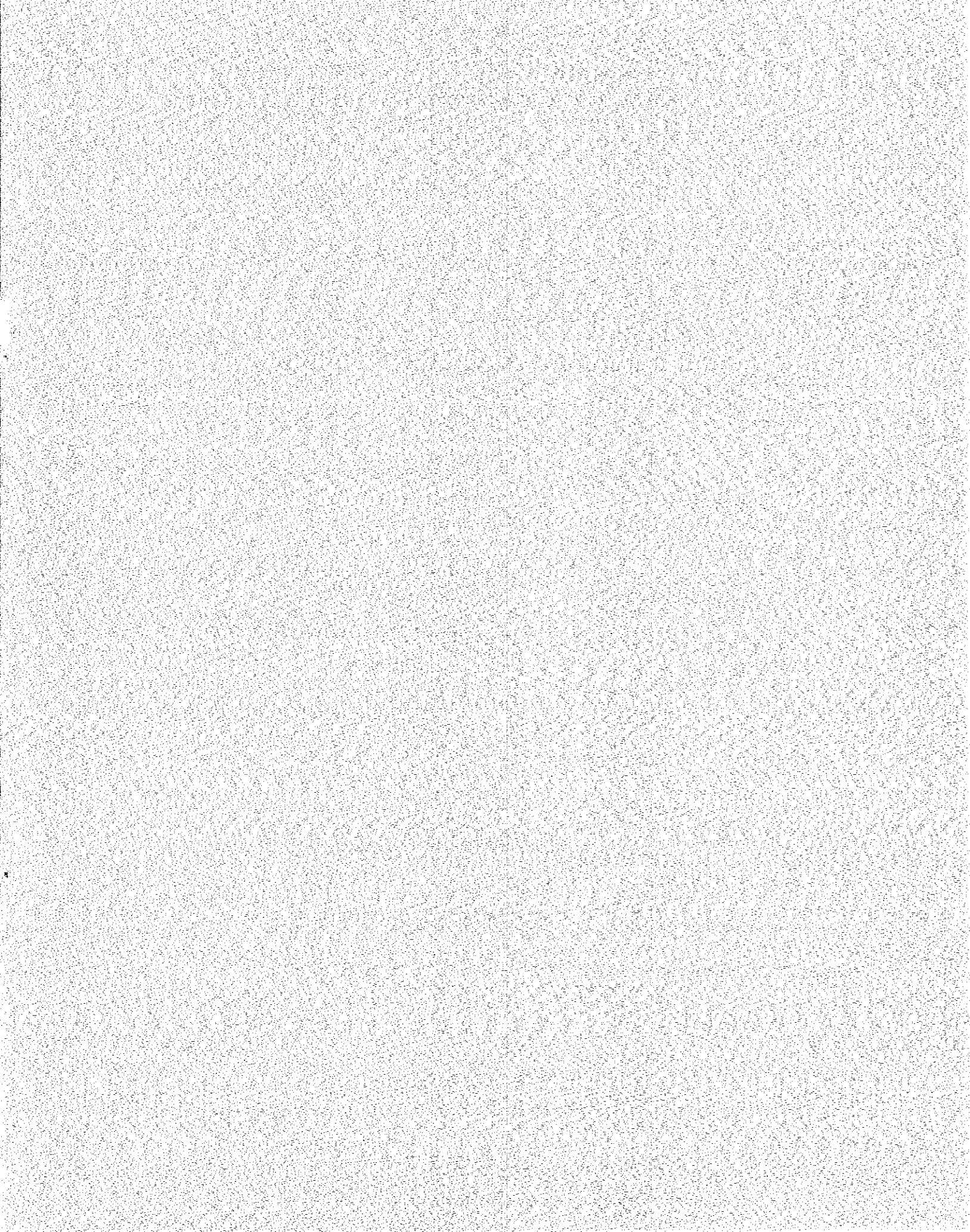



KEITHLEY INSTRUMENTS, INC.

28775 AURORA ROAD • CLEVELAND, OHIO 44139 • (216) 248-0400
TELEX: 98-5469 • CABLE KEITHLEY