

RE-INVENTING TEST & MEASUREMENT THROUGH *SPEED* AND *SIMPLICITY*

Models 2380-500 and 2380-120 Programmable DC Electronic Load Instruments Quick Start Guide



A GREATER MEASURE OF CONFIDENCE

KEITHLEY
A Tektronix Company

Safety precautions

Observe the following safety precautions before using this product and any associated instrumentation. Although some instruments and accessories would normally be used with nonhazardous voltages, there are situations where hazardous conditions may be present.

This product is intended for use by qualified personnel who recognize shock hazards and are familiar with the safety precautions required to avoid possible injury. Read and follow all installation, operation, and maintenance information carefully before using the product. Refer to the user documentation for complete product specifications.

If the product is used in a manner not specified, the protection provided by the product warranty may be impaired.

The types of product users are:

Responsible body is the individual or group responsible for use and maintenance of equipment, for ensuring that the equipment is operated within its specifications and operating limits, and for ensuring that operators are adequately trained.

Operators use the product for its intended function. They must be trained in electrical safety procedures and proper use of the instrument. They must be protected from electric shock and contact with hazardous live circuits.

Maintenance personnel perform routine procedures on the product to keep it operating properly, for example, setting the line voltage or replacing consumable materials. Maintenance procedures are described in the user documentation. The procedures explicitly state if the operator may perform them. Otherwise, they should be performed only by service personnel.

Service personnel are trained to work on live circuits, perform safe installations, and repair products. Only properly trained service personnel may perform installation and service procedures.

Keithley Instruments products are designed for use with electrical signals that are measurement, control, and data I/O connections, with low transient overvoltages and must not be directly connected to mains voltage or to voltage sources with high transient overvoltages. Measurement Category II (as referenced in IEC 60664) connections require protection for high transient overvoltages often associated with local AC mains connections. Certain Keithley measuring instruments may be connected to mains. These instruments will be marked as category II or higher.

Unless explicitly allowed in the specifications, operating manual, and instrument labels, do not connect any instrument to mains.

Exercise extreme caution when a shock hazard is present. Lethal voltage may be present on cable connector jacks or test fixtures. The American National Standards Institute (ANSI) states that a shock hazard exists when voltage levels greater than 30 V RMS, 42.4 V peak, or 60 V DC are present. A good safety practice is to expect that hazardous voltage is present in any unknown circuit before measuring.

Operators of this product must be protected from electric shock at all times. The responsible body must ensure that operators are prevented access and/or insulated from every connection point. In some cases, connections must be exposed to potential human contact. Product operators in these circumstances must be trained to protect themselves from the risk of electric shock. If the circuit is capable of operating at or above 1000 V, no conductive part of the circuit may be exposed.

Do not connect switching cards directly to unlimited power circuits. They are intended to be used with impedance-limited sources. NEVER connect switching cards directly to AC mains. When connecting sources to switching cards, install protective devices to limit fault current and voltage to the card.

Before operating an instrument, ensure that the line cord is connected to a properly-grounded power receptacle. Inspect the connecting cables, test leads, and jumpers for possible wear, cracks, or breaks before each use.

When installing equipment where access to the main power cord is restricted, such as rack mounting, a separate main input power disconnect device must be provided in close proximity to the equipment and within easy reach of the operator.

For maximum safety, do not touch the product, test cables, or any other instruments while power is applied to the circuit under test. ALWAYS remove power from the entire test system and discharge any capacitors before: connecting or disconnecting cables or jumpers, installing or removing switching cards, or making internal changes, such as installing or removing jumpers.

Do not touch any object that could provide a current path to the common side of the circuit under test or power line (earth) ground. Always make measurements with dry hands while standing on a dry, insulated surface capable of withstanding the voltage being measured.

For safety, instruments and accessories must be used in accordance with the operating instructions. If the instruments or accessories are used in a manner not specified in the operating instructions, the protection provided by the equipment may be impaired.

Do not exceed the maximum signal levels of the instruments and accessories, as defined in the specifications and operating information, and as shown on the instrument or test fixture panels, or switching card.

When fuses are used in a product, replace with the same type and rating for continued protection against fire hazard.

Chassis connections must only be used as shield connections for measuring circuits, NOT as protective earth (safety ground) connections.

If you are using a test fixture, keep the lid closed while power is applied to the device under test. Safe operation requires the use of a lid interlock.



If a screw is present, connect it to protective earth (safety ground) using the wire recommended in the user documentation.



This symbol on an instrument means caution, risk of danger. The user should refer to the operating instructions located in the user documentation in all cases where the symbol is marked on the instrument.



This symbol on an instrument means caution, risk of electric shock. Use standard safety precautions to avoid personal contact with these voltages.



This symbol on an instrument shows that the surface may be hot. Avoid personal contact to prevent burns.



This symbol indicates a connection terminal to the equipment frame.



If the mercury symbol is on a product, it indicates that mercury is present in the display lamp. Please note that the lamp must be properly disposed of according to federal, state, and local laws.

WARNING This heading in the user documentation explains dangers that might result in personal injury or death. Always read the associated information very carefully before performing the indicated procedure.

CAUTION This heading in the user documentation explains hazards that could damage the instrument. Such damage may invalidate the warranty.

Instrumentation and accessories shall not be connected to humans.

Before performing any maintenance, disconnect the line cord and all test cables.

To maintain protection from electric shock and fire, replacement components in mains circuits — including the power transformer, test leads, and input jacks — must be purchased from Keithley Instruments. Standard fuses with applicable national safety approvals may be used if the rating and type are the same. Other components that are not safety-related may be purchased from other suppliers as long as they are equivalent to the original component (note that selected parts should be purchased only through Keithley Instruments to maintain accuracy and functionality of the product). If you are unsure about the applicability of a replacement component, call a Keithley Instruments office for information.

To clean an instrument, remove power from the instrument. Use a damp cloth or mild, water-based cleaner. Clean the exterior of the instrument only. Do not apply cleaner directly to the instrument or allow liquids to enter or spill on the instrument. Products that consist of a circuit board with no case or chassis (e.g., a data acquisition board for installation into a computer) should never require cleaning if handled according to instructions. If the board becomes contaminated and operation is affected, the board should be returned to the factory for proper cleaning and servicing. Safety precaution revision of January 2013.

Power and environmental specifications

For indoor use only.

Power supply	100/220 V, 115/230 V, 50 Hz or 60 Hz
Operating altitude	Maximum 2000 m (6562 ft) above sea level
Operating temperature	0 °C to 40 °C (32 °F to 104 °F), full accuracy to 80% relative humidity at up to 35 °C (95 °F), non-condensing
Storage temperature	-20 °C to 70 °C (-4 °F to 158 °F), 10% to 85% relative humidity at up to 40 °C (+104 °F) and 5% to 60% RH above 40 °C (+104 °F) up to 70 °C (+158 °F)
Pollution degree	2



CAUTION

Carefully consider and configure the appropriate input-off state, also source and compliance levels before connecting the instrument to a device. Failure to consider the input-off state and source and limit levels may result in damage to the instrument or to the device under test (DUT).

Introduction

The Keithley Models 2380-500-15/2380J-500-15/2380-120-60/2380J-120-60 programmable high-precision DC electronic load instruments support constant current (CC), constant voltage (CV), constant resistance (CR), constant power (CP), and transient operating modes. Its power ranges from 200 W to 250 W. The resolution of its voltage and current are 0.1 mV and 0.01 mA. Its adjustable current rise and fall times range from 0.0001 A/ μ s to 2.5 A/ μ s. Its measurement speed of voltage and current reaches up to 50 KHz. The load can be controlled externally from 0 through 10 V using analog interfaces. It is equipped with built-in ports of RS232, USB, and GPIB. The load also provides special LED mode to conduct LED power supply test by simulating LED current.

The models are listed in the table.

Model number	Description
2380-500-15/ 2380J-500-15	Programmable DC Electronic Load. 500V, 15A (rated for 110 V, 230 V, nominal line power)
2380-120-60/ 2380J-120-60	Programmable DC Electronic Load. 120V, 60A (rated for 100 V, 200 V, nominal line power)

Overview of the front-panel options

The front panel of the 2380-500-15/2380J-500-15/2380-120-60/2380J-120-60 is shown in the next figure.

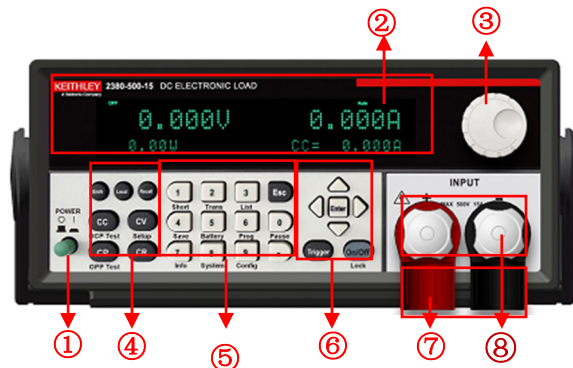

Front panel description:









No.	Description	No.	Description
1	Power On/Off switch	2	VFD display
3	Navigation control	4	Function keys
5	Numeric keypad, Esc key, and combination button	6	Navigation arrow keys, Enter, Trigger and On/Off button
7	Protective cover	8	Input terminals











Keypad overview

The models 2380-500-15/2380J-500-15/2380-120-60/2380J-120-60 keypad on the front panel is shown in the next figure.

Button descriptions:

- : Enables access to secondary functions
- : Sets the instrument to local mode
- : Recalls stored instrument settings
- : Sets the load to CC mode and configures the current value
- : Sets the load to CV mode and configures the voltage value
- : Sets the load to CR mode and configures the resistance value
- : Sets the load to CP mode and configures the power value
- : Sets the load to trigger mode for list and transient function

- : Turns the instrument on or off
- : Confirms settings
- : Up arrow key
- : Down arrow key
- : Left/Right arrow keys
-  ~ : Enters numeric values for various parameters
- : Decimal point
- : Cancels the current action and returns to the previous menu

Safety

Introduction

Unpack

Connect

Test

FAQs
Next steps

Rear Panel Overview

The models 2380-500-15/2380J-500-15/2380-120-60/2380J-120-60 rear panel interface is shown in the next figure:

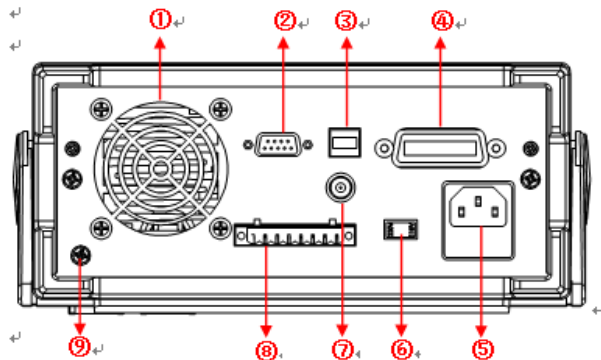

Rear panel description:

No.	Description	No.	Description
1	Cooling fan	2	RS232 interface
3	USB interface	4	GPIB interface
5	AC socket (fuse inside)	6	Line voltage selector
7	I-monitor interface	8	Remote sense terminals, external trigger and programming input terminals
9	Protective ground terminal		

Unpack and inspect the instrument

To unpack and inspect the instrument:

1. Inspect the box for damage.
2. Open the top of the box.
3. Remove the bag that contains the documentation, standard accessories, and CD-ROM.
4. Remove the packaging inserts.
5. Remove the instrument from the box.



Do not lift the programmable DC electronic load from the front bezel. Lifting the instrument by the terminal blocks of front bezel can cause instrument damage.

6. Inspect the instrument for any obvious signs of physical damage. Report any damage to the shipping agent immediately.

You should receive one of the following instruments: Model 2380-500-15/2380J-500-15/2380-120-60/2380J-120-60 with the following accessories and documentation:

No	Part Number	Description
1	CO-XX/161-XXXX-XX	Power line cord
2	063456100	Programmable DC Electronic Load Product Information CD-ROM
3	001165500	Calibration Certificate
4	174684100	USB cable
5	PA-935	Environmental Disclosure Statement (Instrument/System)

Refer to the packing list which comes with the shipment for additional items that are shipped with your instrument.

CD-ROM contents

The CD ROM that is shipped with the instrument contains PDFs of the User Manual, Quick Start Guide, and accessory manuals. For additional support information, visit <http://www.keithley.com/support>.

Connect the instrument

Important test system safety information

This product is sold as a stand-alone instrument that may become part of a system that could contain hazardous voltages and energy sources. It is the responsibility of the test system designer, integrator, installer, maintenance personnel, or service personnel to make sure the system is safe during use and is operating properly.

It is important that you consider the following factors in your system design and use:

- The international safety standard IEC 61010-1 defines voltages as hazardous if they exceed 30 V_{RMS} and 42.4 V peak, or 60 V DC for equipment rated for dry locations. Keithley Instruments products are only rated for dry locations.
- Read and comply with the specifications of all instruments in the system. The overall allowed signal levels may be constrained by the lowest rated instrument in the system. For example, if you are using a 500 V power supply with a 300 V DC rated switch, the maximum allowed voltage in the system is 300 V DC.

- Make sure any test fixture connected to the system protects the operator from contact with hazardous voltages, hot surfaces, and sharp objects. Use shields, barriers, insulation, and safety interlocks to accomplish this.
- Cover the DUT to protect the operator from flying debris in the event of a system or DUT failure.
- Double-insulate all electrical connections that an operator can touch. Double insulation ensures the operator is still protected even if one insulation layer fails. Refer to IEC 61010-1 for specific requirements.
- Make sure all connections are behind a locked cabinet door or other barrier. This protects the system operator from accidentally removing a connection by hand and exposing hazardous voltages. Use high-reliability fail-safe interlock switches to disconnect power sources when a test fixture cover is opened.
- Where possible, use automatic handlers so operators are not required to access the DUT or other potentially hazardous areas.

Provide training to all users of the system so they understand all potential hazards and know how to protect themselves from injury.

NOTE

To keep users safe, always read and follow all safety warnings provided with each of the instruments in your system.

Safety

Introduction

Unpack

Connect

Test

FAQs
Next steps

Install the instrument

You can use a Model 2380-500-15/2380J-500-15/2380-120-60/2380J-120-60 instrument on a bench or in a rack. Please see the instructions that came with your rack-mount kit if you are installing the programmable DC electronic load in a rack.

To prevent damaging heat build-up and ensure specified performance, make sure there is adequate ventilation and air flow around the instrument to ensure proper cooling. Do not cover the ventilation holes on the top, sides, or bottom of the instrument.

Make sure the instrument is positioned so that it is easy to reach any disconnecting devices, such as the power cord and the power switch.

Power up the instrument

The Model 2380-500-15/2380J-500-15/2380-120-60/2380J-120-60 instrument operate at 100 V, 115 V, 220 V, or 230 V with a frequency of 50 Hz or 60 Hz. Make sure that the AC line voltage indicator in the center of the rear-panel power module matches the AC line voltage in your facility as shown in the next figure.

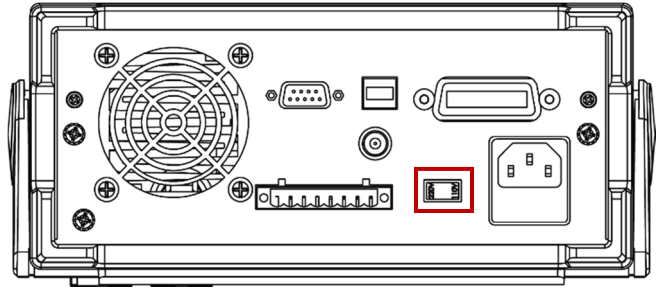

WARNING

The power cord supplied with 2380-500-15/2380J-500-15/2380-120-60/2380J-120-60 contains a separate protective earth (safety ground) wire for use with grounded outlets. When proper connections are made, the instrument chassis is connected to power-line ground through the ground wire in the power cord. In addition, a redundant protective earth connection is provided through a screw on the rear panel. This terminal should be connected to a known protective earth. In the event of a failure, not using a properly grounded protective earth and grounded outlet may result in personal injury or death due to electric shock.

Do not replace detachable mains supply cords with inadequately rated cords. Failure to use properly rated cords may result in personal injury or death due to electric shock.

To connect line power:

1. Turn **POWER OFF** (use front panel power switch).
2. Move the line voltage selector, on the rear panel, to the correct voltage level (230 V or 115 V).
3. Connect the power cord to the AC socket on the rear panel.

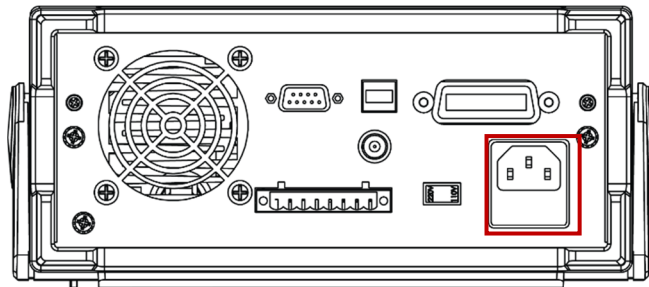

CAUTION

Operating the instrument on an incorrect line voltage may cause damage to the instrument, possibly voiding the warranty.

4. Connect the other end of the power cord to a grounded AC outlet.
5. Turn **POWER ON** (use the front panel). The instrument is powered up.

Safety

Introduction

Unpack

Connect

Test

FAQs
Next steps

Connections for testing

Before making the connections, prepare the wires as described in the next table.

Connection	Specifications
Front panel input terminals	20 AWG to 12 AWG
Sense terminals	



CAUTION

The wire must be heavy enough not to overheat while carrying the short-circuit input current of the unit. Make sure to meet the wiring requirements described above.

Two-wire connection

Two-wire connection is used for basic operations when maximum precision is not required. Keep the wire as short as possible to reduce wire resistance. If you want higher measurement precision, use four-wire remote sense connection.

To connect the DUT to the load using a two-wire connection:

- 1 Unscrew the two nuts and remove the two protective covers, as shown in the next figure.

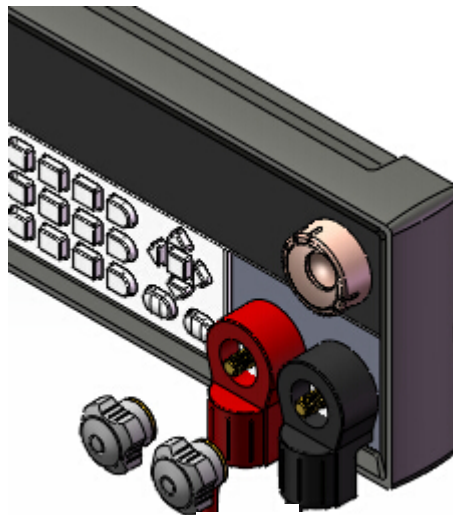

Safety

Introduction

Unpack

Connect

Test

FAQs
Next steps

- 2 Connect the cables to the two input terminals, as shown in next figure.

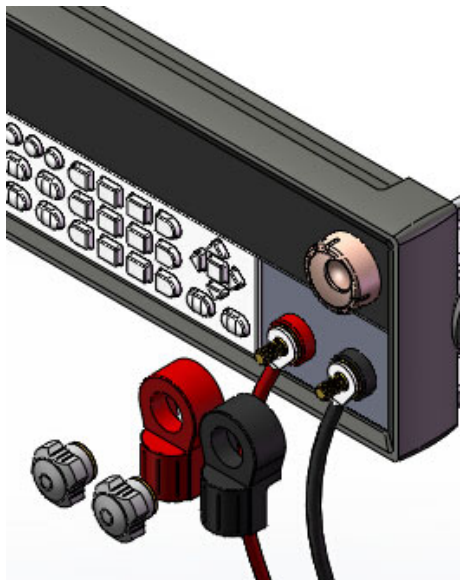

- 3 Mount the protective covers to the two input terminals.

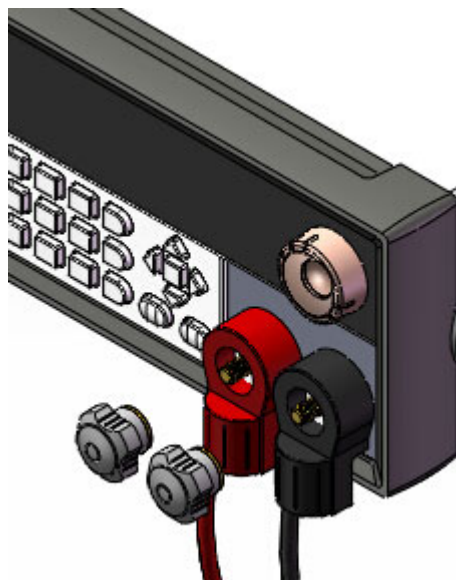

4 Screw the two input terminals tight, as shown in the next figure.

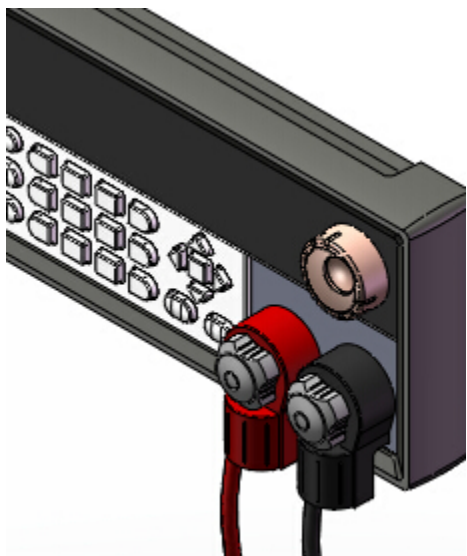

5 Connect the other end of the cables to the DUT. The red cable is connected to the positive electrode and the black cable is connected to the negative electrode.

 **WARNING**

Failure to install the protective cover may result in personal injury or death due to electric shock.

Safety

Introduction

Unpack

Connect

Test

FAQs
Next steps

Four-wire remote sense connection

You can use four-wire remote sense connections for higher measurement precision.

To connect the DUT to the load using a four-wire remote sense connection:

- 1 Unscrew the two nuts and remove the two protective covers.
- 2 Connect the cables to the two input terminals.
- 3 Mount the protective covers to the two input terminals.
- 4 Screw the two input terminals tight.
- 5 Connect the other end of the cables to the DUT. The red cable is connected to the positive electrode and the black cable is connected to the negative electrode.
- 6 Connect the DUT to the remote sense terminals on the rear panels, as shown in the next wiring diagram.

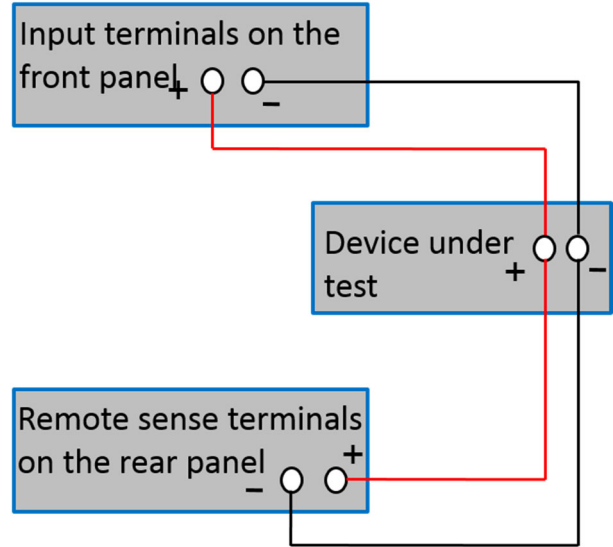

NOTE

Steps 1 through 5 above are the same as the steps for two-wire connection. For the illustrations of the steps, see [Two-wire connection](#).

Front-panel user interface overview

The front-panel user interface gives you quick access to measurement settings, system configuration, instrument status, and other instrument functionality.

Home screen overview

When you turn on the instrument, you will see the home screen, as shown in the next figure.

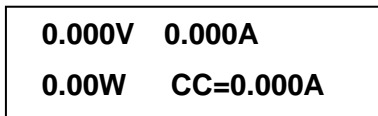

The top row on the home screen displays the actual input voltage and current values.

The second row on the home screen displays the actual power value and the current (voltage, power, resistance) setting values.

Menu screen overview

When you press **Shift** + **8** on the front panel, the **SYSTEM MENU** screen is displayed.

The following options are displayed on the VFD: Initialize, Power-ON, Buzzer, Knob, Trigger, Display, Communication, and Protocol.

Select an option by pressing **Enter**, and configure the parameters.

When you press **Shift** + **9** on the front panel, the **CONFIG MENU** screen is displayed.

The following options are displayed on the VFD: Von, Protect, Measure, CR-LED, Remote-Sense, and Ext-Program.

Select an option by pressing **Enter**, and configure the parameters.

Safety

Introduction

Unpack

Connect

Test

FAQs
Next steps

Select a measure function



The programmable DC electronic load allows you to perform the following measure functions.

Measure functions	What the instrument measures
Short function	Simulate a short circuit with an input
Transient mode	Conduct a dynamic response time test for a power supply
OCP Function	Conduct an automatic test for OCP conditions
OPP Function	Conduct an automatic test for OPP conditions
Battery mode	Conduct a battery capacity test by sinking a fixed current load
CR-LED mode	Conduct an output current test for an LED power supply
Measure mode	Conduct a rising/falling time test for a power supply or a fuse melting time test.
Autotest function	Conduct an automatic test with various modes



Front panel key combinations for measurement functions are as follows:



 +  (Short) : Enable/Disable short function.



 +  (Tran) : Configure transient parameters

 +  (List) : Configure list parameters

 +  (Battery) : Configure battery test parameters.

 +  (Program) : Configure autotest parameters.

 +  (OCP Test) : Configure OCP parameters

 +  (Setup) : Configure maximum voltage/current range for each function

Shift + **CP** (OPP Test) : Configure OPP parameters

Specify a measurement range

You can set value ranges for measurements or allow the instrument to choose the ranges automatically.

The measurement range determines the input during the measurement, and also affects the precision of the measurements and the maximum signal that can be measured.

You can specify the current range and voltage range for the programmable DC electronic load. The ranges are listed in the next table.

To set the ranges for CC/CV/CR/CP mode from the front panel :

1. Press the **CC/CV/CR/CP** key.
2. Press **Shift** + **CV**.
3. Set the range of each parameter according to the following table.

Model number	Current measurement range	Voltage measurement range
2380-500-15/ 2380J-500-15	3 ~ 15 A	50 ~ 500 V
2380-120-60/ 2380J-120-60	6 ~ 60 A	18 ~ 120 V

4. Press **Enter**.

See the "Constant-status operation mode" section of the User Manual for additional details and the specific parameters configuration.

Safety

Introduction

Unpack

Connect



Test

FAQs
Next steps

Configure and execute a 2-step linear list sweep



The following example demonstrates how to set the electronic load to input a linear list sweep from 1 A to 3 A. The values demonstrated in the example are default settings. Each step in the list sweep remains for five seconds. The list is stored in list location one. The input will turn on at 0 A and return to 0 A at the end of the list execution.

To configure a list on the front panel:

1. Press  + , the following text is displayed.



LIST

Off Recall Edit



2. Press  , select Edit. Then press  to confirm, the following text is displayed.

EDIT LIST

High-Rate Low-Rate

3. Press  , select High-Rate. Then press  to confirm, the following text is displayed.

EDIT LIST
Current Range=3A

4. Edit step count. For example, press  for two steps, and then press  to confirm, the following text is displayed.

EDIT LIST
File Step=2 (2-84)

5. Edit the current value for step 1, press  to confirm, the following text is displayed.

EDIT LIST
Step 001 Level=1A

6. Edit the current slope for step 1, press  to confirm, the following text is displayed.

EDIT LIST
Step 001 Rate=0.1A/uS

7. Edit the width time for step 1, press  to confirm, the following text is displayed.

EDIT LIST
Step 001 Width=5S

8. Edit the current value for step 2, press  to confirm, the following text is displayed.

EDIT LIST
Step 002 Level=2A

9. Edit the current slope for step 2, press  to confirm, the following text is displayed.

EDIT LIST
Step 002 Rate=0.1A/uS

10. Edit the width time for step 2, press  to confirm, the following text is displayed.

EDIT LIST
Step 002 Width=5S



11. Edit the list repeating times, press  to confirm, the following text is displayed.

EDIT LIST
Repeat Count=3

12. Save list file and press  to confirm, the following text is displayed.

EDIT LIST







Save List File=1 (1-7)

13. Press  , select **On** and press  to confirm. The



Trig indicator light turns on. Then press  to quit the list operation when the following text is displayed.

LIST

On Recall Edit

14. Press  to turn on the load input.
15. Press  to generate a trigger signal.
16. If you want to quit list operation, press  /  /  /  or any other combination keys.

To execute a list sweep on the front panel:



1. Press **Shift** + **3** and make sure the on/off button is in flickering state. If not, press **Enter**, and press   to select **Recall**, then press **Enter** to confirm, the following text is displayed.

LIST

Off Recall Edit

2. Select the pre-saved list file and press **Enter** to confirm, the following text is displayed.

Recall List File=1

3. Press  , and select **Off**, press **Enter** to turn it on. The Trig indicator light turns on. Press **Esc** to quit the list operation when the following text is displayed.

LIST

On Recall Edit

4. Press **On/Off** button to turn on the input, press **Trigger** to run the list.

Next steps

For more information, refer to the Product Information CD-ROM, which includes the User Manual, Quick Start Guide, and accessory information. These documents provide detailed information about all features of the instrument.

Also see the Keithley Instruments website, www.keithley.com for support and additional information about the instrument.

Safety

Introduction

Unpack

Connect

Test

FAQs
Next steps

Specifications are subject to change without notice. All Keithley trademarks and trade names are the property of Keithley Instruments, Inc.
All other trademarks and trade names are the property of their respective companies.

KEITHLEY

A Tektronix Company

A Greater Measure of Confidence

KEITHLEY INSTRUMENTS, INC. ■ 28775 AURORA RD. ■ CLEVELAND, OH 44139-1891 ■ 440-248-0400 ■ Fax: 440-248-6168 ■ 1-888-KEITHLEY ■ www.keithley.com

BENELUX

+31-40-267-5506
www.keithley.nl

FRANCE

+33-01-69-86-83-60
www.keithley.fr

ITALY

+39-049-762-3950
www.keithley.it

MALAYSIA

60-4-643-9679
www.keithley.com

SINGAPORE

01-800-8255-2835
www.keithley.com.sg

BRAZIL

55-11-4058-0229
www.keithley.com

GERMANY

+49-89-84-93-07-40
www.keithley.de

JAPAN

81-120-441-046
www.keithley.jp

MEXICO

52-55-5424-7907
www.keithley.com

TAIWAN

886-3-572-9077
www.keithley.com.tw

CHINA

86-10-8447-5556
www.keithley.com.cn

INDIA

080-30792600
www.keithley.in

KOREA

82-2-6917-5000
www.keithley.co.kr

RUSSIA

+7-495-664-7564
www.keithley.ru

UNITED KINGDOM

+44-1344-39-2450
www.keithley.co.uk

For further information on how to purchase or to locate a sales partner please visit www.keithley.com/company/buy

