



**4 Series B MSO
(MSO44B and MSO46B)
Service Manual**

Register now!
Click the following link to protect your product.
tek.com/register



077-1823-00 March 2024

Copyright © 2024, Tektronix. 2024 All rights reserved. Licensed software products are owned by Tektronix or its subsidiaries or suppliers, and are protected by national copyright laws and international treaty provisions. Tektronix products are covered by U.S. and foreign patents, issued and pending. Information in this publication supersedes that in all previously published material. Specifications and price change privileges reserved. All other trade names referenced are the service marks, trademarks, or registered trademarks of their respective companies.

TEKTRONIX and TEK are registered trademarks of Tektronix, Inc.

Tektronix, Inc.
14150 SW Karl Braun Drive
P.O. Box 500
Beaverton, OR 97077
US

For product information, sales, service, and technical support visit [tek.com](https://www.tek.com) to find contacts in your area. For warranty information visit [tek.com/warranty](https://www.tek.com/warranty).

Contents

Important safety information.....	5
General safety summary.....	5
To avoid fire or personal injury.....	5
Probes and test leads.....	7
Service safety summary.....	7
Terms in this manual.....	8
Terms on the product.....	8
Symbols on the product.....	8
Preface.....	9
Supported products.....	9
Where to find operating information.....	9
Theory of operation.....	10
Power supply.....	10
Processor board.....	10
Main board.....	11
Front panel, display, and Probe Interface Board (PIB).....	11
Maintenance.....	12
Preventing ESD.....	12
Adjustment procedures.....	12
Inspection and cleaning.....	13
Exterior cleaning (other than display).....	13
Flat panel display cleaning.....	13
Interior cleaning.....	14
Lubrication.....	14
Returning instrument for service.....	15
Removal and replacement procedures.....	15
Required equipment.....	15
Remove the front-panel knobs.....	16
Remove instrument feet.....	17
Remove the handle.....	18
Remove the rear grill and case.....	19
Remove the rear chassis assembly.....	21
Remove the power supply bracket.....	23
Remove the power supply.....	25
Remove the main fan assembly.....	28
Remove the processor board.....	29
Remove the main board.....	30
Troubleshooting.....	32
Service level.....	32
Check for common problems.....	32
Troubleshooting flow chart.....	33
Check that the instrument passes power-on self tests.....	34
Download and install the latest instrument firmware.....	34
After repair.....	34

Replaceable parts.....	35
Rear case assembly with handle and feet.....	36
Front assembly.....	37
Rear chassis assembly.....	39
Front panel assembly.....	41
Front chassis assembly.....	43

Important safety information

This manual contains information and warnings that must be followed by the user for safe operation and to keep the product in a safe condition.

To safely perform service on this product, see the *Service safety summary* that follows the *General safety summary*.

General safety summary

Use the product only as specified. Review the following safety precautions to avoid injury and prevent damage to this product or any products connected to it. Carefully read all instructions. Retain these instructions for future reference.

This product shall be used in accordance with local and national codes.

For correct and safe operation of the product, it is essential that you follow generally accepted safety procedures in addition to the safety precautions specified in this manual.

The product is designed to be used by trained personnel only.

Only qualified personnel who are aware of the hazards involved should remove the cover for repair, maintenance, or adjustment.

Before use, always check the product with a known source to be sure it is operating correctly.

This product is not intended for detection of hazardous voltages.

Use personal protective equipment to prevent shock and arc blast injury where hazardous live conductors are exposed.

While using this product, you may need to access other parts of a larger system. Read the safety sections of the other component manuals for warnings and cautions related to operating the system.

When incorporating this equipment into a system, the safety of that system is the responsibility of the assembler of the system.

To avoid fire or personal injury

Use proper power cord

Use only the power cord specified for this product and certified for the country of use. Do not use the provided power cord for other products.

Ground the product

This product is grounded through the grounding conductor of the power cord. To avoid electric shock, the grounding conductor must be connected to earth ground. Before making connections to the input or output terminals of the product, ensure that the product is properly grounded. Do not disable the power cord grounding connection.

Power disconnect

The power cord disconnects the product from the power source. See instructions for the location. Do not position the equipment so that it is difficult to operate the power cord; it must remain accessible to the user at all times to allow for quick disconnection if needed.

Connect and disconnect properly

Do not connect or disconnect probes or test leads while they are connected to a voltage source.

Use only insulated voltage probes, test leads, and adapters supplied with the product, or indicated by Tektronix to be suitable for the product.

Observe all terminal ratings

To avoid fire or shock hazard, observe all rating and markings on the product. Consult the product manual for further ratings information before making connections to the product.

Do not exceed the Measurement Category (CAT) rating and voltage or current rating of the lowest rated individual component of a product, probe, or accessory. Use caution when using 1:1 test leads because the probe tip voltage is directly transmitted to the product.

Do not apply a potential to any terminal, including the common terminal, that exceeds the maximum rating of that terminal.

Do not float the common terminal above the rated voltage for that terminal.

The measurement terminals on this product are not rated for connection to Category III or IV circuits.

Do not operate without covers

Do not operate this product with covers or panels removed, or with the case open. Hazardous voltage exposure is possible.

Avoid exposed circuitry

Do not touch exposed connections and components when power is present.

Do not operate with suspected failures

If you suspect that there is damage to this product, have it inspected by qualified service personnel.

Disable the product if it is damaged. Do not use the product if it is damaged or operates incorrectly. If in doubt about safety of the product, turn it off and disconnect the power cord. Clearly mark the product to prevent its further operation.

Before use, inspect voltage probes, test leads, and accessories for mechanical damage and replace when damaged. Do not use probes or test leads if they are damaged, if there is exposed metal, or if a wear indicator shows.

Examine the exterior of the product before you use it. Look for cracks or missing pieces.

Use only specified replacement parts.

Do not operate in wet/damp conditions

Be aware that condensation may occur if a unit is moved from a cold to a warm environment.

Do not operate in an explosive atmosphere

Keep product surfaces clean and dry

Remove the input signals before you clean the product.

Provide proper ventilation

Refer to the installation instructions in the manual for details on installing the product so it has proper ventilation.

Slots and openings are provided for ventilation and should never be covered or otherwise obstructed. Do not push objects into any of the openings.

Provide a safe working environment

Always place the product in a location convenient for viewing the display and indicators.

Avoid improper or prolonged use of keyboards, pointers, and button pads. Improper or prolonged keyboard or pointer use may result in serious injury.

Be sure your work area meets applicable ergonomic standards. Consult with an ergonomics professional to avoid stress injuries.

Use care when lifting and carrying the product. This product is provided with a handle or handles for lifting and carrying.

Use only the Tektronix rackmount hardware specified for this product.

Probes and test leads

Before connecting probes or test leads, connect the power cord from the power connector to a properly grounded power outlet.

Keep fingers behind the protective barrier, protective finger guard, or tactile indicator on the probes. Remove all probes, test leads and accessories that are not in use.

Use only correct Measurement Category (CAT), voltage, temperature, altitude, and amperage rated probes, test leads, and adapters for any measurement.

Beware of high voltages

Understand the voltage ratings for the probe you are using and do not exceed those ratings. Two ratings are important to know and understand:

- The maximum measurement voltage from the probe tip to the probe reference lead.
- The maximum floating voltage from the probe reference lead to earth ground.

These two voltage ratings depend on the probe and your application. Refer to the Specifications section of the manual for more information.



WARNING: To prevent electrical shock, do not exceed the maximum measurement or maximum floating voltage for the oscilloscope input BNC connector, probe tip, or probe reference lead.

Connect and disconnect properly

Connect the probe output to the measurement product before connecting the probe to the circuit under test. Connect the probe reference lead to the circuit under test before connecting the probe input. Disconnect the probe input and the probe reference lead from the circuit under test before disconnecting the probe from the measurement product.

De-energize the circuit under test before connecting or disconnecting the current probe.

Connect the probe reference lead to earth ground only.

Do not connect a current probe to any wire that carries voltages or frequencies above the current probe voltage rating.

Inspect the probe and accessories

Before each use, inspect probe and accessories for damage (cuts, tears, or defects in the probe body, accessories, or cable jacket). Do not use if damaged.

Service safety summary

The *Service safety summary* section contains additional information required to safely perform service on the product. Only qualified personnel should perform service procedures. Read this *Service safety summary* and the *General safety summary* before performing any service procedures.

To avoid electric shock

Do not touch exposed connections.

Do not service alone

Do not perform internal service or adjustments of this product unless another person capable of rendering first aid and resuscitation is present.

Disconnect power

To avoid electric shock, switch off the product power and disconnect the power cord from the mains power before removing any covers or panels, or opening the case for servicing.

Use care when servicing with power on

Dangerous voltages or currents may exist in this product. Disconnect power, remove battery (if applicable), and disconnect test leads before removing protective panels, soldering, or replacing components.

Verify safety after repair

Always recheck ground continuity and mains dielectric strength after performing a repair.

Terms in this manual

These terms may appear in this manual:



WARNING: Warning statements identify conditions or practices that could result in injury or loss of life.



CAUTION: Caution statements identify conditions or practices that could result in damage to this product or other property.

Terms on the product

These terms may appear on the product:

- DANGER indicates an injury hazard immediately accessible as you read the marking.
- WARNING indicates an injury hazard not immediately accessible as you read the marking.
- CAUTION indicates a hazard to property including the product.

Symbols on the product



When this symbol is marked on the product, be sure to consult the manual to find out the nature of the potential hazards and any actions which have to be taken to avoid them. (This symbol may also be used to refer the user to ratings in the manual.)

The following symbols(s) may appear on the product.



CAUTION: Refer to Manual



Protective Ground (Earth) Terminal



Chassis Ground



Standby



Functional Earth Terminal

Preface

This manual contains service information for your instrument.

Read the General and Service safety summaries before servicing the product.

Be sure to read the introductions to all procedures. These introductions provide important information needed to perform the service correctly, safely, and efficiently.

Supported products

This manual contains information that is necessary to service the MSO44 and MSO46 instruments.

Check for a specific product designation in the header at the top of the page, in a heading, table or figure title, or within text. Material that does not have any specific product designation applies to all products in the manual.

Where to find operating information

For information on installing, operating, and networking the instrument, refer to the online help or user manual that was provided with your oscilloscope. You can also find the manual at tek.com, by searching for your product.

Theory of operation

This chapter describes the electrical operation of the oscilloscope to the module level. The block diagram shows the oscilloscope module interconnections.

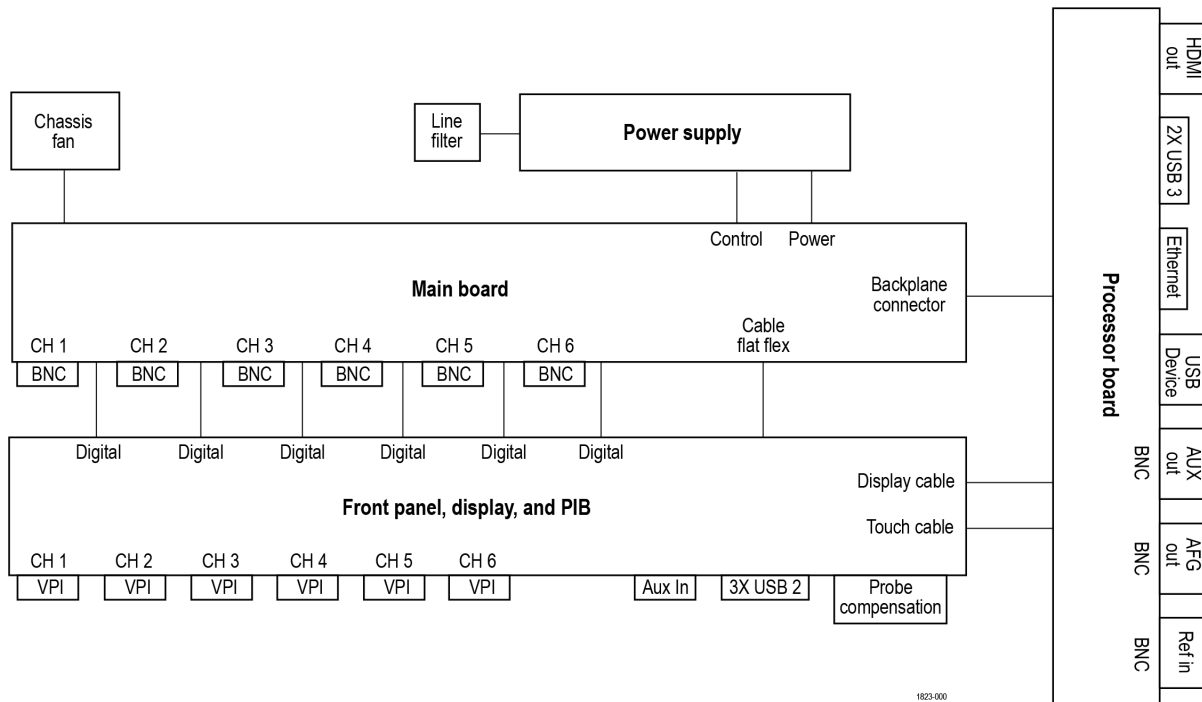

Figure 1: 4 Series B MSO block diagram

Power supply

The Power Supply board converts AC line voltage to +12 V to power for all internal circuits.

Processor board

The processor board contains the following functions:

Processor system

The processor system contains a microprocessor that controls the entire instrument. The processor system also contains the flash memory for the operating system, system RAM, and interfaces to I/O ports and the acquisition system.

Rear panel I/O ports

The processor board contains two USB3 ports, an Ethernet port (LAN), a HDMI Video port, the USB-TMC port, an AUX OUT BNC connector, an EXT REF IN BNC connector, and the AFG Out generator BNC connector.

Other functions

The processor board also houses the AFG generator, USB-TMC controller and USB host hub.

Main board

The Main board contain the following functions:

Acquisition system	The Acquisition system begins with the analog signal path and ends with a digitized signal in memory. The signal enters a channel input, and then passes through an attenuator and preamplifier. The analog signal from each preamplifier goes through a digitizer, and then into acquisition memory. The analog signal from each preamplifier is also distributed to a trigger circuit.
Analog Front-end	All of the analog and digital inputs are routed to the analog Front-end circuitry. The analog channels are amplified and attenuated through the front-end circuitry, and are output to the acquisition ASICs. The digital channels simply pass through the front-end circuitry to the acquisition ASICs.
Power converter	The +12 V power from the bulk supply is converted to lower voltages for the analog and digital circuitry throughout the system. Standby power is used to keep portions of the system powered at all times that AC power is connected to the instrument.
Other functions	The Main board interfaces to the Power supply and various cooling fans.

Front panel, display, and Probe Interface Board (PIB)

The Front Panel board contains digital logic that reads the front-panel buttons and controls and sends this information to the processor system on the Processor board. The Front Panel board also generates the probe compensation output signal, provides USB2 ports on the front panel. The PIB routes the digital front-end signals from the probe directly to the main board and houses the main power switch.

Maintenance

This section contains information needed to perform periodic and corrective maintenance on the instrument.

Preventing ESD

Before servicing this product, read the *General Safety Summary* and the *Service Safety Summary* at the front of the manual, as well as the following ESD information.



CAUTION: Electrostatic discharge (ESD) can damage any semiconductor component in this instrument.

When performing any service that requires internal access to the instrument, adhere to the following precautions to avoid damaging internal modules and their components due to electrostatic discharge:

1. Minimize handling of static-sensitive circuit boards and components.
2. Transport and store static-sensitive modules in their static protected containers or on a metal rail. Label any package that contains static-sensitive boards.
3. Discharge the static voltage from your body by wearing a grounded antistatic wrist strap while handling these modules.
4. Service static-sensitive modules only at a static-free work station.
5. Do not allow any items capable of generating or holding a static charge on the work station surface.
6. Handle circuit boards by the edges when possible.
7. Do not slide the circuit boards over any surface.
8. Avoid handling circuit boards in areas that have a floor or work-surface covering capable of generating a static charge.

Adjustment procedures

Adjustment and calibration must be performed by a Tektronix Service Center.

Go to tek.com to find information on contacting Tektronix Service Support.

Adjustment interval

The voltage and timing references inside the instrument are very stable over time and do not need routine adjustment.

If the instrument fails the performance tests in the Specifications and Performance Verification Manual, adjustment may be required. To download the Specification and Performance Verification Manual go to tek.com/support/product-support, search for the model number of your instrument in the field, and select the Specification and Performance Verification document to download under Manuals.

If your organization requires periodic calibration, a general rule is to verify performance and make adjustments (only if needed) every 2000 hours of operation or once a year if the instrument is used infrequently.

Adjustment after repair

After removal and replacement of any module, you must perform the *Performance Verification* procedures, found in the Specifications and Performance Verification Manual, available to download from tek.com.

If the instrument fails any Performance Verification tests, it must be returned to a Tektronix Service Center for adjustment and calibration.

Inspection and cleaning

This section describes how to inspect for dirt and damage. It also describes how to clean the exterior and interior of the instrument.

Inspection and cleaning are done as preventive maintenance. Preventive maintenance, when done regularly, may prevent instrument malfunction and enhance its reliability.

Preventive maintenance consists of visually inspecting and cleaning the instrument and using general care when operating it.

How often to perform maintenance depends on the severity of the environment in which the instrument is used. A proper time to perform preventive maintenance is just before instrument adjustment.

Exterior cleaning (other than display)

Clean the exterior surfaces of the chassis with a dry lint-free cloth or a soft-bristle brush. If any dirt remains, use a cloth or swab dipped in a 75% isopropyl alcohol solution. Use a swab to clean narrow spaces around controls and connectors. Do not use abrasive compounds on any part of the chassis that may damage the chassis.

Clean the On/Standby switch using a cleaning towel dampened with deionized water. Do not spray or wet the switch itself.



CAUTION: Avoid the use of chemical cleaning agents which might damage the plastics used in this instrument. Use only deionized water when cleaning the front-panel buttons. Use a 75% isopropyl alcohol solution as a cleaner for cabinet parts. Before using any other type of cleaner, consult your Tektronix Service Center or representative.

Inspection - Exterior. Inspect the outside of the instrument for damage, wear, and missing parts. Immediately repair defects that could cause personal injury or lead to further damage to the instrument.

Table 1: External inspection checklist

Item	Inspect for	Repair action
Cabinet, front panel, and cover	Cracks, scratches, deformations, damaged hardware	Repair or replace defective module
Front-panel knobs	Missing, damaged, or loose knobs	Repair or replace missing or defective knobs
Connectors	Broken shells, cracked insulation, and deformed contacts. Dirt in connectors	Repair or replace defective modules. Clear or brush out dirt
Carrying handle and cabinet feet	Correct operation	Repair or replace defective module
Accessories	Missing items or parts of items, bent pins, broken or frayed cables, and damaged connectors	Repair or replace damaged or missing items, frayed cables, and defective modules

Flat panel display cleaning

Clean the flat panel display surface by gently rubbing the display with a clean-room wipe (such as Wypall Medium Duty Wipes, #05701, available from Kimberly-Clark Corporation), or an abrasive-free cleaning cloth.

If the display is very dirty, moisten the wipe or cloth with distilled water, a 75% isopropyl alcohol solution, or standard glass cleaner, and gently rub the display surface. Use only enough liquid to dampen the cloth or wipe. Avoid using excess force or you may damage the display surface.

CAUTION: Improper cleaning agents or methods can damage the flat panel display.



- Do not use abrasive cleaners or surface cleaners to clean the display.
- Do not spray liquids directly on the display surface.
- Do not scrub the display with excessive force.



CAUTION: To prevent getting moisture inside the instrument during external cleaning, do not spray any cleaning solutions directly onto the screen or instrument.

Interior cleaning

You can only clean the interior of the rear chassis assembly. To access the rear chassis assembly, see the *Removal and Installation Procedures* topics.

Do not disassemble or clean the front chassis assembly (other than cleaning the front panel display and removing panel knobs). Disassembling the front chassis assembly requires that the instrument be returned to your nearest Tektronix Service Center for calibration.



WARNING: To avoid electric shock or damage to the instrument, remove instrument power. Before performing any procedure that follows, power down the instrument and disconnect it from line voltage.

- Blow off dust with dry, low-pressure (approximately 9 psi), deionized air.
- Use a soft-bristle, non-static-producing brush for cleaning around components.
- Remove any remaining dust with a lint-free cloth dampened in isopropyl alcohol (75% solution). (A cotton-tipped applicator is useful for cleaning in narrow spaces and on circuit boards).
- If you must use a liquid for minor rear chassis interior cleaning, use a clean-room wipe (such as Wypall Medium Duty Wipes, #05701, available from Kimberly-Clark Corporation) dampened with a 75% isopropyl alcohol solution.
- Inspect the internal portions of the instrument for damage and wear. See [Table 2](#) on page 14. Defects should be repaired immediately.
- If any circuit board is repaired or replaced, you must perform the Performance Verification procedure in the specifications and performance verification manual, which was provided with your instrument. This manual is also available at www.tektronix.com/manuals, by searching for your product name. If the instrument fails the Performance Verification tests, it must be returned to a Tektronix Service Center for repair and calibration.



CAUTION: To prevent damage from electrical arcing, ensure that circuit boards and components are dry before applying power to the instrument.

Table 2: Internal inspection checklist

Item	Inspect for	Repair action
Circuit boards	Loose, broken, or corroded solder connections. Burned circuit boards. Burned, broken, or cracked circuit-run plating.	Remove and replace damaged circuit board.
Resistors	Burned, cracked, broken, blistered condition.	
Capacitors	Damaged or leaking cases. Corroded solder on leads or terminals.	
Wiring and cables	Loose plugs or connectors. Burned, broken, or frayed wiring.	Firmly seat connectors. Replace defective cables.
Chassis	Dents, deformations, and damaged hardware.	Straighten, repair, or replace defective hardware.

Lubrication

There is no periodic lubrication required for this instrument.

Returning instrument for service

Use the following instructions for returning your instrument for service.

When repacking the instrument for shipment, use the original packaging. If the packaging is not available or unfit for use, contact your local Tektronix representative to obtain new packaging.

If you need to return your instrument for repair or calibration, call 1-800-438-8165 or complete the form at tek.com/services/repair/ma-request. When you request service, have the serial number, firmware, and software version of the instrument.

If you want to see the warranty or service agreements on your products, or if you want to create your own service price estimate, visit our quick service quote site at tek.com/service-quote.

Removal and replacement procedures

This section contains procedures for removal and installation of replaceable modules in the instrument. Refer to the *Replaceable parts* section for lists and exploded views of replaceable modules.

Any module inside of the chassis that does not have a remove and replace procedure requires that the entire instrument be returned to Tektronix Service Center for service.



WARNING: Before performing this or any other procedure in this manual, read the safety summaries found at the beginning of this manual. Also, to prevent possible injury to service personnel or damage to the instrument components, read *Preventing ESD*.

Before performing any procedure in this subsection, disconnect the power cord from the line voltage source. Failure to do so could cause serious injury or death.



Note: Read the cleaning procedure before disassembling the instrument for cleaning.

Required equipment

Most assemblies in this instrument can be removed with a T-10 or T8 Torx® screwdriver tip.

Table 3: Required equipment for removal and replacement

Name	Description
Screwdriver handle	Accepts Torx-driver bits
Phillips-head tip	Used for removing Phillips-head screws on instrument
T-10 Torx tip	Used for removing instrument screws. Torx-driver bit for T-10 size screw heads
T-8 Torx tip	Used for removing instrument screws. Torx-driver bit for T-8 size screw heads
9/16 inch open-end wrench	Used to remove nut posts
Proper antistatic work environment	To prevent electrostatic damage to components whenever you work on the instrument, wear properly-grounded electrostatic prevention wrist and foot straps, and work in a tested antistatic environment on an antistatic mat.

Remove the front-panel knobs

The following procedure describes the removal and replacement of the front-panel knob assemblies.

Before you begin

To prevent electrostatic damage to components whenever you work on the instrument, wear properly-grounded electrostatic prevention wrist and foot straps, and work in a tested antistatic environment on an antistatic mat.

About this task

There are eight knob assemblies that can be removed from the front case.

Procedure

To remove a knob assembly, pull the knob straight out of the front panel. Finger strength is adequate to pull knobs. Do not use pliers.

Results

To reinstall a knob, align the knob with the shaft indent and push the knob onto the shaft. Turn the knob to make sure there is a smooth rotation.

Remove instrument feet

The following procedure describes the removal and replacement of the instrument feet.

Before you begin

To prevent electrostatic damage to components whenever you work on the instrument, wear properly-grounded electrostatic prevention wrist and foot straps, and work in a tested antistatic environment on an antistatic mat.

About this task

There are two feet that can be removed from the bottom of the instrument.

Procedure

1. Remove all cables and the power cord from the rear panel.
2. Set the instrument on its back side so the bottom is facing you.
3. Flip open both feet assemblies.
4. Use a screwdriver with T-10 Torx tip to remove the four screws from each foot assembly.



5. Remove the feet assemblies.

Results

To reinstall, reverse the above steps. Use a screwdriver with T-10 Torx tip to secure the eight screws. First insert and tighten the screws that are near the front edge of the instrument, then insert and tighten the screws that are near the rear edge of the instrument. Tighten to 0.65 N·m.

Remove the handle

The following procedure describes the removal and replacement of the handle.

Before you begin

To prevent electrostatic damage to components whenever you work on the instrument, wear properly-grounded electrostatic prevention wrist and foot straps, and work in a tested antistatic environment on an antistatic mat.

Procedure

1. Use a screwdriver with T-10 Torx tip to remove two screws from each side of the handle.



2. Disengage the handle from the pins on the couplers and remove the handle.



3. Remove the two couplers.

Results

To reinstall, reverse the above steps. Use a screwdriver with T-10 Torx tip to secure the screws. Tighten to 0.65 N·m.

Remove the rear grill and case

The following procedure describes the removal and replacement of the rear grill and case.

Before you begin

To prevent electrostatic damage to components whenever you work on the instrument, wear properly-grounded electrostatic prevention wrist and foot straps, and work in a tested antistatic environment on an antistatic mat.

Procedure

1. Use a screwdriver with T-10 Torx tip to remove the 10 screws securing the grill to the rear case.

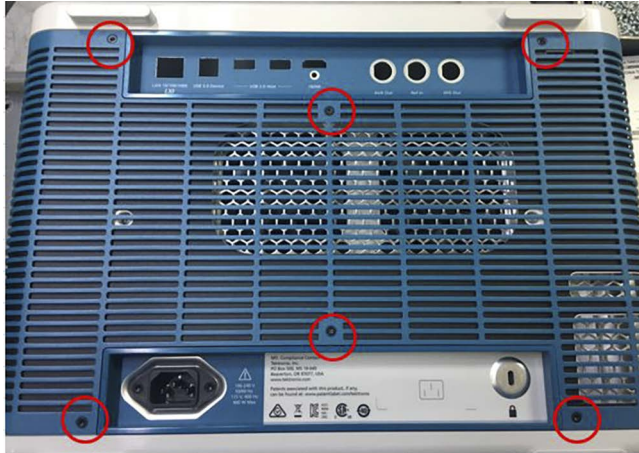

2. Put fingers in handle hub holes on both side of the grill and pull the grill from the rear case.
3. Use a screwdriver with T-10 Torx tip to remove the six screws securing the rear case to the rear chassis.



4. Slide away the rear case from the rear chassis.

Results

To reinstall, reverse the above steps. Tighten the six T-10 Torx rear case screws to 0.65 N·m.

Remove the rear chassis assembly

The following procedure describes the removal and replacement of the rear chassis assembly.

Before you begin

To prevent electrostatic damage to components whenever you work on the instrument, wear properly-grounded electrostatic prevention wrist and foot straps, and work in a tested antistatic environment on an antistatic mat.

Remove the rear grill and case.

Procedure

1. Use a 9/16" socket to remove BNCs with three washers and three nuts.

Black arrow is for nut and red arrow is for washer.



2. Use a screwdriver with a with T-10 Torx tip to remove the 25 screws securing the rear chassis to the front chassis.

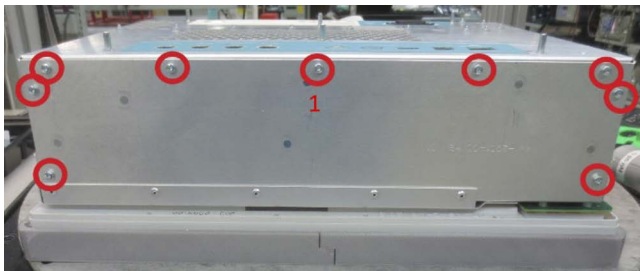



3. Carefully lift the rear chassis off of the front chassis and disconnect the power cables, fan cables, and line filter cable.

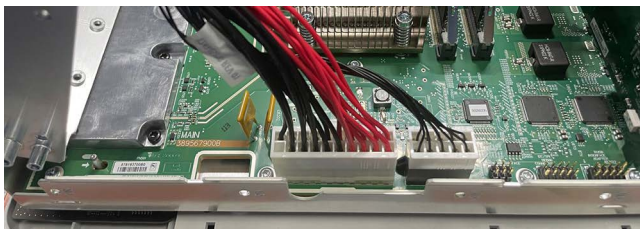

Results

To reinstall, reverse the above steps. Tighten the 25 screws with T-10 bit to 0.65 N·m.
Secure BNCs with three washers and three nuts using 9/16" socket and 2.5 N.M hand driver.

Remove the power supply bracket

The following procedure describes the removal and replacement of the power supply bracket.

Before you begin

- To prevent electrostatic damage to components whenever you work on the instrument, wear properly-grounded electrostatic prevention wrist and foot straps, and work in a tested antistatic environment on an antistatic mat.
- Remove the rear grill and case.
- Remove the rear chassis assembly.

Procedure

1. Set the rear chassis with the rear side down.
2. Use a screwdriver with a with T-10 Torx tip to remove the 15 screws from the power supply bracket.

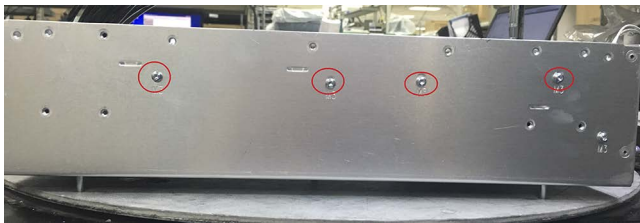

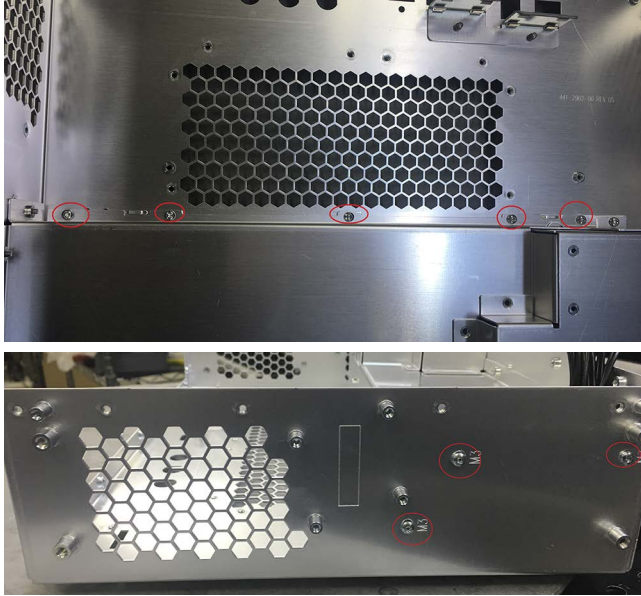

Results

To reinstall, reverse the above steps. Tighten the 15 screws with T-10 bit to 0.65 N·m. to attach the power supply bracket to chassis with the order of the red arrow.

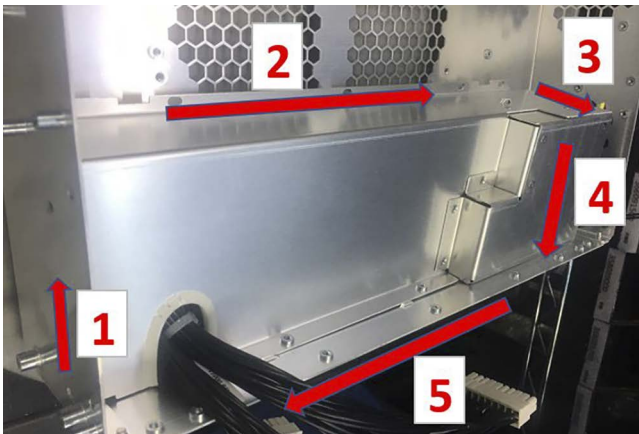

Remove the power supply

The following procedure describes the removal and replacement of the power supply.

Before you begin

- To prevent electrostatic damage to components whenever you work on the instrument, wear properly-grounded electrostatic prevention wrist and foot straps, and work in a tested antistatic environment on an antistatic mat.
- Remove the rear grill and case.
- Remove the rear chassis assembly.

Procedure

1. Flip open the power supply shield.

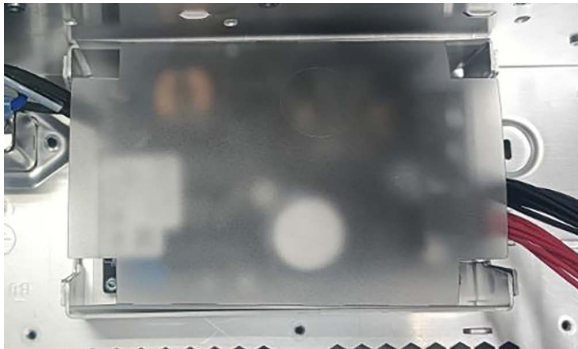

2. Disconnect the line input cable from the power supply.

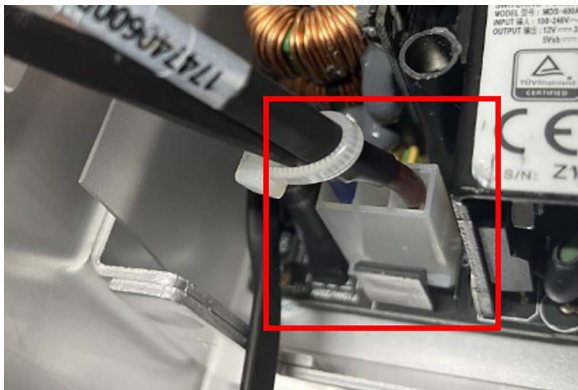

3. Use a T-10 Torx screwdriver to remove the two screws from the cable block.

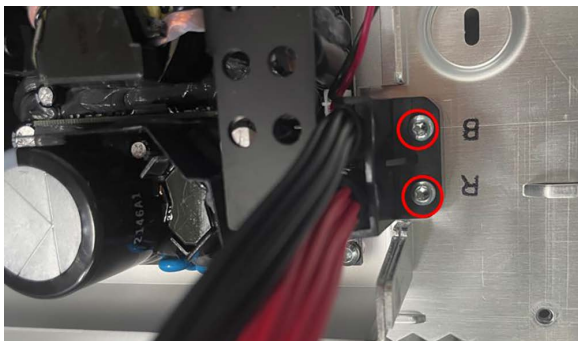

4. Remove the cable block.

5. Use a T-10 Torx screwdriver to remove the four screws from the power supply.

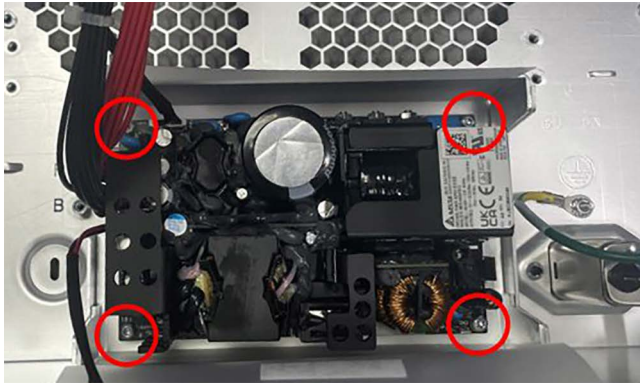

6. Remove the power supply from the chassis.
7. Disconnect the main board cable from the power supply.



8. Use a Phillips-head screwdriver to remove the two screws securing the power supply cable.

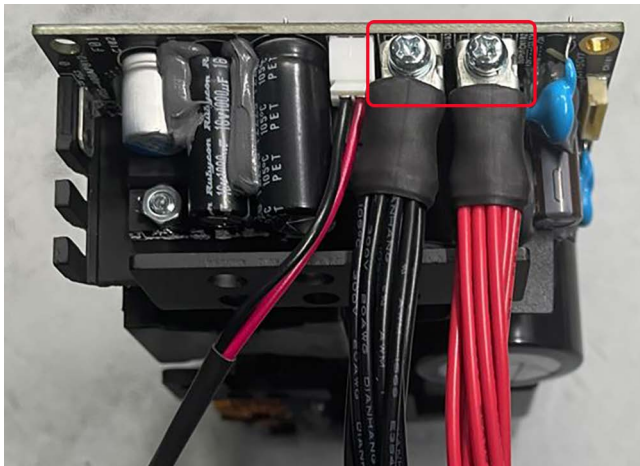

9. Disconnect the fan cable from the power supply.

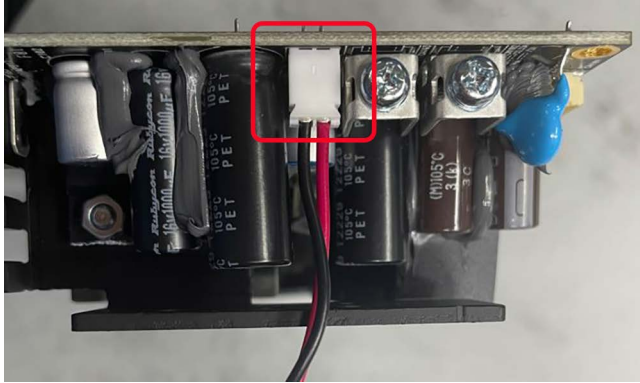

Results

To reinstall, reverse the steps. Tighten the T-10 Torx screws to 0.65 N·m when reinstalling. Tighten the Phillips-head screws to 0.75 N·m when reinstalling.

Make sure the color of the cable aligns with the letter on the chassis. "R" equals red and "B" equals black.

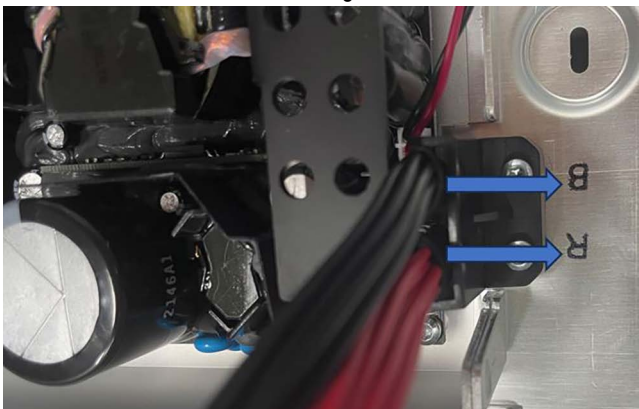

When placing the power supply back into the chassis, place the fan cable as shown in the image below (indicated by the blue dots).



Remove the main fan assembly

The following procedure describes the removal and replacement of the power supply bracket.

Before you begin

- To prevent electrostatic damage to components whenever you work on the instrument, wear properly-grounded electrostatic prevention wrist and foot straps, and work in a tested antistatic environment on an antistatic mat.
- Remove the rear grill and case.
- Remove the rear chassis assembly.

Procedure

1. Use a T-10 Torx screwdriver to remove the seven screws from the main fan assembly bracket.

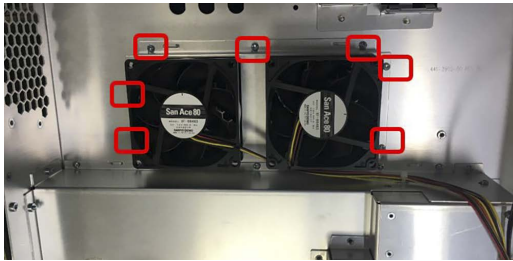

2. Remove the cable ties and main fan assembly from the rear chassis.

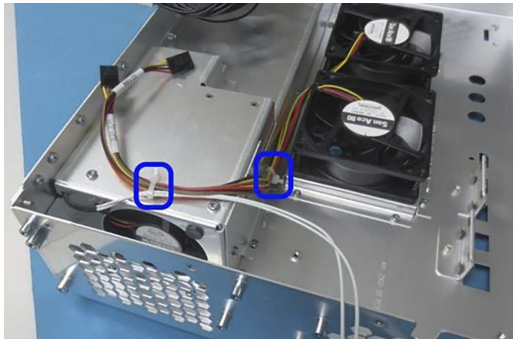

3. To remove the fan from the bracket, carefully pull the fan from each corner of the bracket to disconnect the elastic fan attachments.

Results

To reinstall, reverse the steps. Install the fan on the bracket in the correct orientation for the fan power cable (see photo). Use a needle nose pliers to reinstall the fan elastic attachments on each corner. Tighten the T-10 Torx screws to 0.65 N·m when reinstalling.



When reinstalling the cable ties, include the power supply fan cable on the top cable tie location.

Remove the processor board

The following procedure describes the removal and replacement of the processor board.

Before you begin

- To prevent electrostatic damage to components whenever you work on the instrument, wear properly-grounded electrostatic prevention wrist and foot straps, and work in a tested antistatic environment on an antistatic mat.
- Remove the front chassis assembly.

Procedure

1. Use a T-10 Torx screwdriver to remove the seven screws that have attached the processor board to the front chassis assembly.

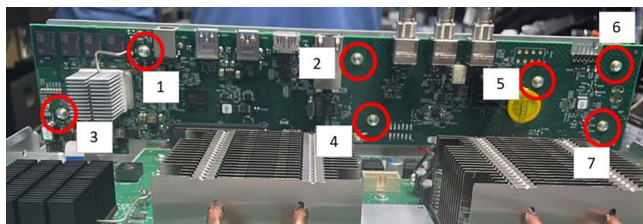

2. Carefully disconnect the processor board from the main board.

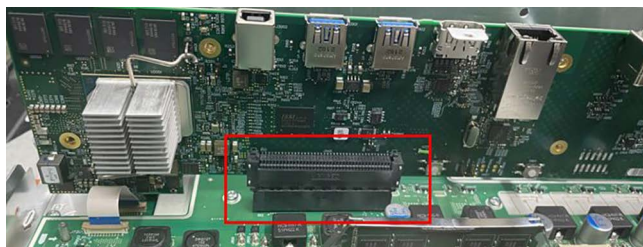

3. Disconnect the display cables from the processor board.

- a) Remove the small display cable as shown below.

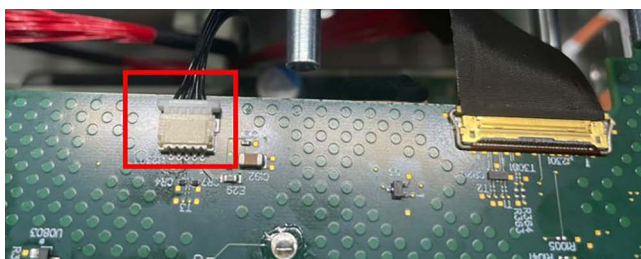

- b) To disconnect the large display cable, flip up the connector clip and slide the cable out of the connector.

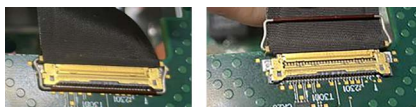

Results

To reinstall, reverse the above steps. Tighten the T-10 Torx screws to 0.65 N·m when reinstalling.

After reconnecting the display cables, make sure to lock the cable clip.

Remove the main board

The following procedure describes the removal and replacement of the main board.

Before you begin

- To prevent electrostatic damage to components whenever you work on the instrument, wear properly-grounded electrostatic prevention wrist and foot straps, and work in a tested antistatic environment on an antistatic mat.
- Remove the front chassis assembly.
- Remove the processor board.

Procedure

1. Disconnect the front panel cable from the main board as shown below.

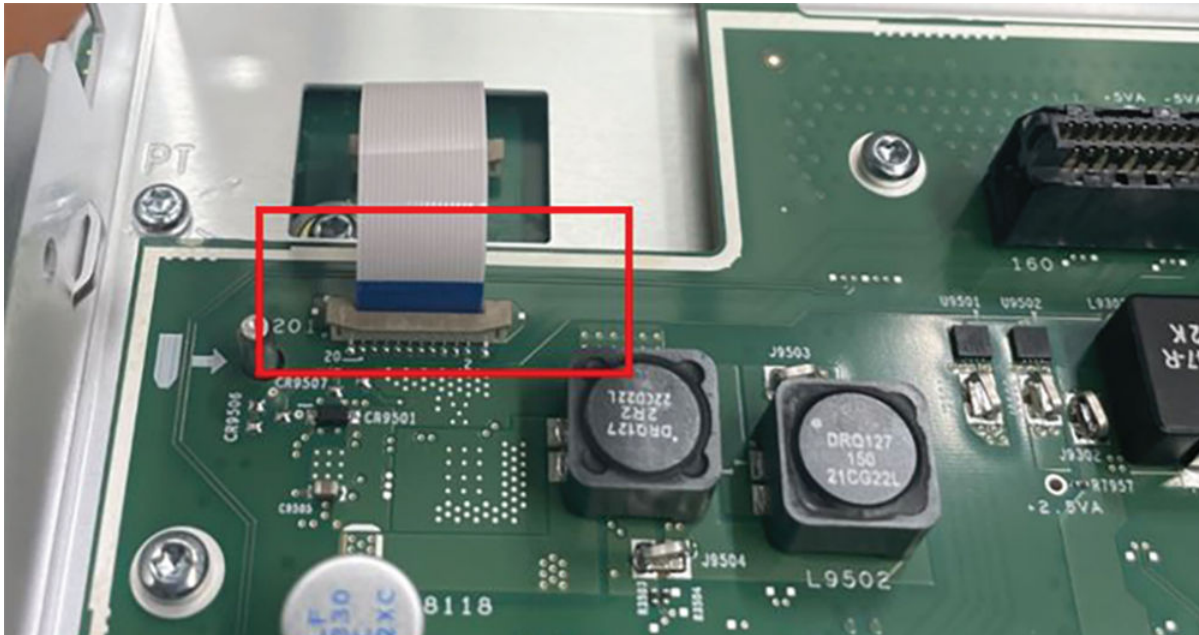

2. Use a T-10 Torx screwdriver to remove the 23 screws that have attached the main board to the front chassis assembly.

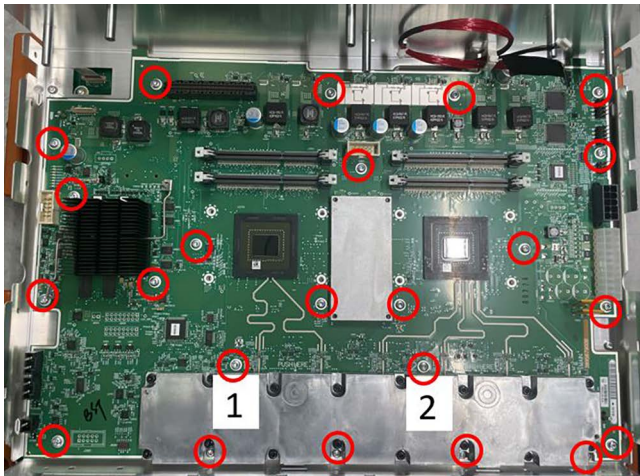

3. Remove main board from chassis.

Results

To reinstall, reverse the above steps. Tighten the T-10 Torx screws to 0.65 N·m when reinstalling.

Push down at the locations shown in the following image to fully engage the main board connectors.

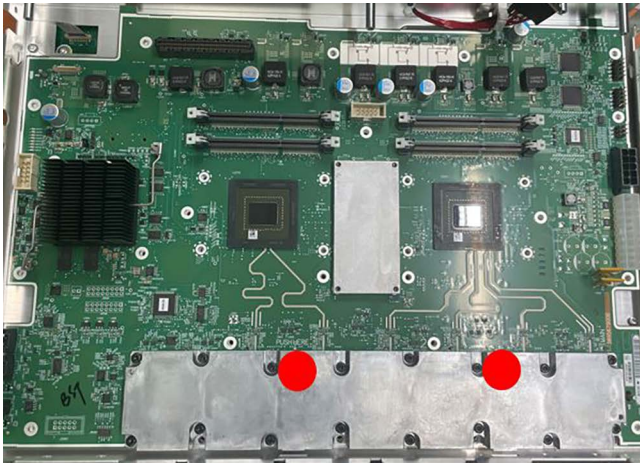

Troubleshooting

This section contains information and procedures designed to help you isolate faults to a module.



CAUTION: Before performing this or any other procedure in this manual, read the General Safety Summary and Service Safety Summary found at the beginning of this manual. To prevent possible injury to service personnel or damage to electrical components, please read information on Preventing ESD.

This section requires that service personnel have the appropriate skills to work on this instrument, including PC troubleshooting and Microsoft Windows operating system skills. Details of PC and Windows operation and service are not in this manual.

For assistance, contact your local Tektronix Service Center.

Service level

This subsection contains information and procedures to help you determine if a faulty power supply is the problem with your instrument. For a faulty power supply, return the instrument to a Tektronix Service Center for repair.

Check for common problems

Use the following table to help isolate possible failures. The table lists problems and possible causes. The list is not exhaustive, but it may help you eliminate a problem that is quick to fix, such as a loose power cord. For more detailed troubleshooting, see the [Troubleshooting flow chart](#) on page 33.

Table 4: Failure symptoms and possible causes

Symptom	Possible cause(s)
Instrument will not power on	Power cord not plugged in
	Faulty power supply
Instrument powers on, but one or more fans will not operate	Faulty fan power cable
	Fan power cable not connected to circuit board
	Defective fan
	Faulty power supply
	One or more defective point of load regulators
Flat-panel display blank or has streaks in display	Faulty LCD screen or video circuitry
Touch sensor in display does not work or has limited use	Display cable not fully seated on display assembly
	Display cable not fully seated on processor board

Troubleshooting flow chart

Follow the troubleshooting flow chart to determine the action for a fault condition.

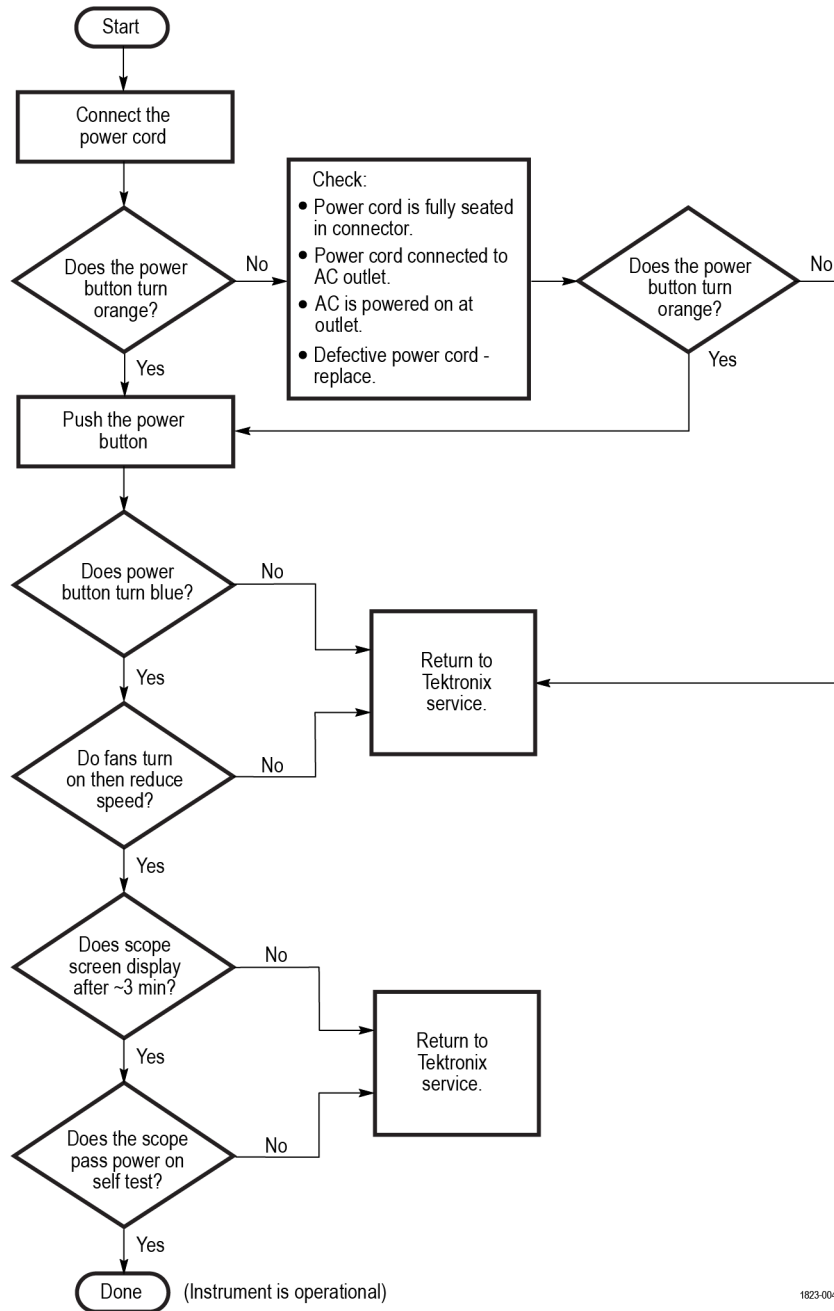

1823-004

Figure 2: Primary troubleshooting tree

Check that the instrument passes power-on self tests

Power-on self tests verify that all instrument modules are working correctly after power up.

Procedure

1. Power on the instrument and wait until the instrument screen appears.
2. Select **Utility > Self Test** from the top-edge Menu bar to open the **Self Test** configuration menu.
3. Check that the status of all power-on self tests are **Passed**.

If one or more power-on self tests shows **Failed**:

- a) Power cycle the instrument.
- b) Tap **Utility > Self Test**. If one or more power-on self tests still shows **Failed**, contact Tektronix Customer Support.

Download and install the latest instrument firmware

Installing the latest firmware helps ensure that your instrument has the latest features and is taking the most accurate measurements.

Before you begin

Save any important on-instrument files (waveforms, screen captures, setups, and so on) to a USB drive or network. The installation process does not remove user-created files, but it is a good idea to back up important files before an update.

Procedure

1. Power on the oscilloscope.
2. Determine the current version of firmware installed on the instrument in the **About** window under the **Help** menu
3. Check the version of the latest available firmware at the tek.com/software. Enter the model number of your oscilloscope in the search box and search for the firmware.

If the firmware version on the web is newer than what is currently installed, update your instrument firmware.

4. Install the firmware on embedded OS instruments.
 - a) Download the latest firmware and unzip the files on your PC.
 - b) Copy the designated firmware file into the root folder of a USB flash drive.
 - c) Insert the USB flash drive into a USB port on your oscilloscope. The instrument automatically recognizes the firmware install file and starts the installation process.
 - d) Follow any on-screen instructions. The oscilloscope take about 10 minutes to install the new firmware.
Do not remove the USB flash drive or power off the instrument during this time.
 - e) After the oscilloscope displays a message that it has completed the upgrade, the scope will reboot automatically.

What to do next

To confirm the firmware update, locate the version number found in the **About** window under the **Help** menu. Confirm that the instrument firmware version number matches the firmware version number that you just installed.

After repair

After removal and replacement of the power supply module, you must perform the Performance Verification procedures, found in the Specifications and Performance Verification Manual. Download all instrument manuals from tek.com.

If the instrument fails the Performance Verification tests, it must be returned to a Tektronix Service Center for adjustment.

Replaceable parts

This section contains separate subsections for different product groups. Use the lists in the appropriate section to identify and order replacement parts for your product. The standard accessories your instrument are listed on tek.com.

Replacement parts are available through your local Tektronix field office or representative.

Parts ordering information

Changes to Tektronix products are sometimes made to accommodate improved components as they become available and to give you the benefit of the latest improvements. Therefore, when ordering parts, it is important to include the following information in your order:

- Part number
- Instrument type or model number
- Instrument serial number
- Instrument modification number, if applicable

If you order a part that has been replaced with a different or improved part, your local Tektronix field office or representative will contact you concerning any change in part number.

Module servicing

Modules can be serviced by selecting one of the following three options. Contact your local Tektronix Service Center or representative for repair assistance.

Module exchange. In some cases, you may exchange your module for a re-manufactured module. These modules cost significantly less than new modules and meet the same factory specifications. For more information about the module exchange program, call 1-800-833-9200. Outside North America, contact a Tektronix sales office or distributor; see tek.com for a list of offices.

Module repair and return. You may ship your module to Tektronix for repair, after which it will be returned to you.

New modules. You may purchase replacement modules in the same way as other replacement parts.

Abbreviations

Abbreviations conform to American National Standard ANSI Y1.1-1972.

Using the replaceable parts list

Use the following table describes each column in the parts list.

Table 5: Parts list column descriptions

Column	Column name	Description
1	Figure & index number	Items in this section are referenced by figure and index numbers to the exploded view illustrations that follow.
2	Tektronix part number	Use this part number when ordering replacement parts from Tektronix.
3 and 4	Serial number	Column three indicates the serial number at which the part was first effective. Column four indicates the serial number at which the part was discontinued. No entry indicates the part is good for all serial numbers.
5	Qty	This indicates the quantity of parts used.
6	Name & description	An item name is separated from the description by a colon (:). Because of space limitations, an item name may sometimes appear as incomplete. Use the U.S. Federal Catalog handbook H6-1 for further item name identification.

Rear case assembly with handle and feet

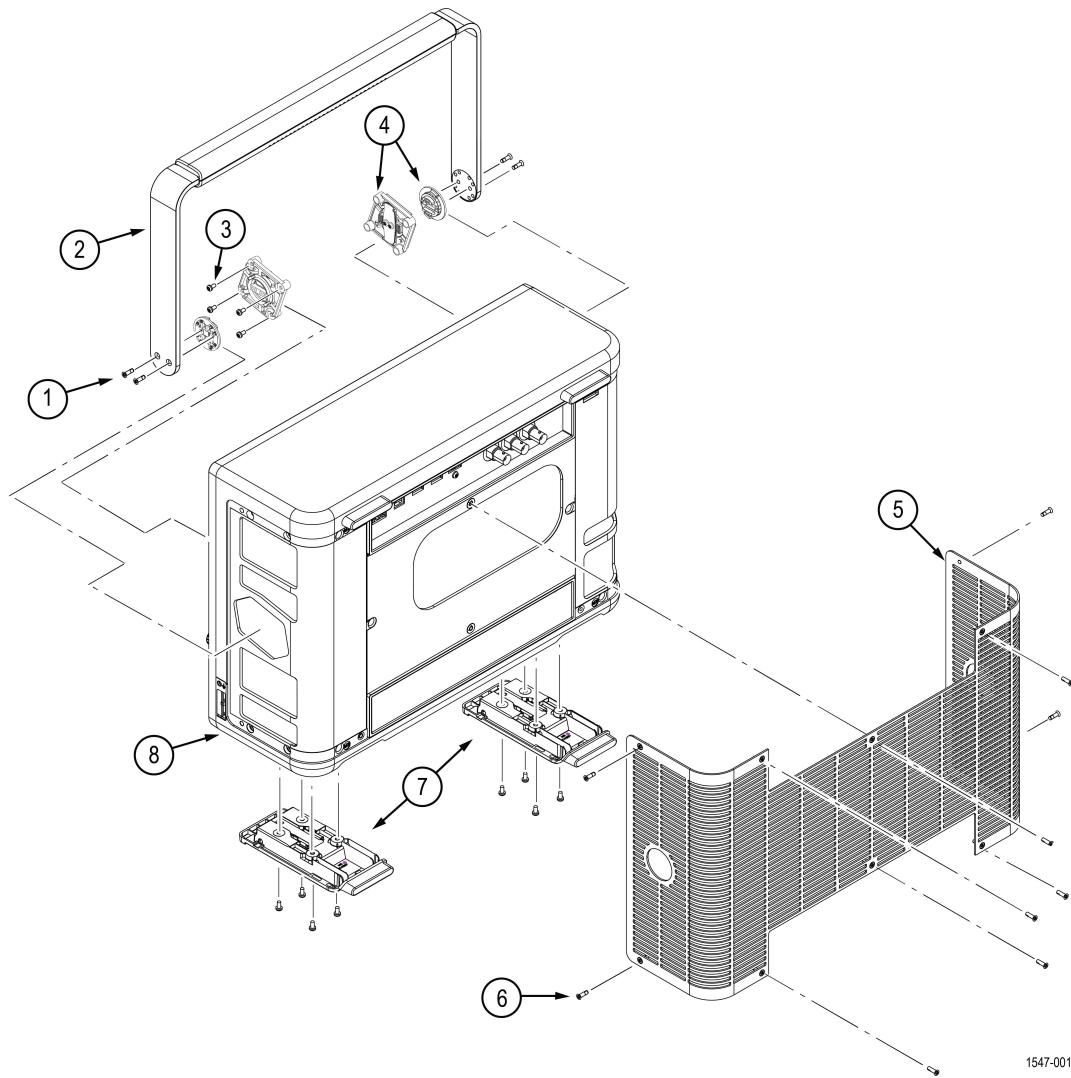

1547-001

Figure 3: Rear case assembly with handle and feet exploded view

Table 6: Rear case assembly parts list

Index number	Part number	Serial no. effective	Serial no. discount'd	Qty	Description
-1	211-1688-XX			4	SCREW, MACHINE, M3X0.5X10, FLAT HEAD 90 DEG, SUS410 NYLOK, TORX T10
-2	050-3906-XX			1	MODULE ASSY:SERVICE REPLACEMENT KIT, HANDLE METAL BASE W/PLASTIC GRIP AND HARDWARE, MSO4 SERIES
-3	211-1636-XX			4	SCREW, MACHINE, M3X0.5X8MM PAN HEAD, TORX T10 WITH NYLON PATCH
-4	065-1058-XX			1	MODULE ASSY: SERVICE REPLACEMENT KIT; HANDLE HUB LEFT AND RIGHT (SET), MSO4 SERIES
-5	378-0961-XX			1	GRILL, COSMETIC, REAR, MSO4K SERIES, SAFETY CONTROLLED

Table continued...

Index number	Part number	Serial no. effective	Serial no. discontin'd	Qty	Description
-6	211-1686-XX			12	SCREW, MACHINE, M3X0.5X10 FLATHEAD, 90 DEG, BLACK ZINC, TUFLOK, TORX T10
-7	065-1047-XX			2	MODULE ASSY: SERVICE REPLACEMENT KIT; REAR FLIP FEET, MSO4 SERIES
-8	202-0578-XX			1	CASE, REAR, W/BLACK LABELS, MSO4K SERIES, SAFETY CONTROLLED

Front assembly

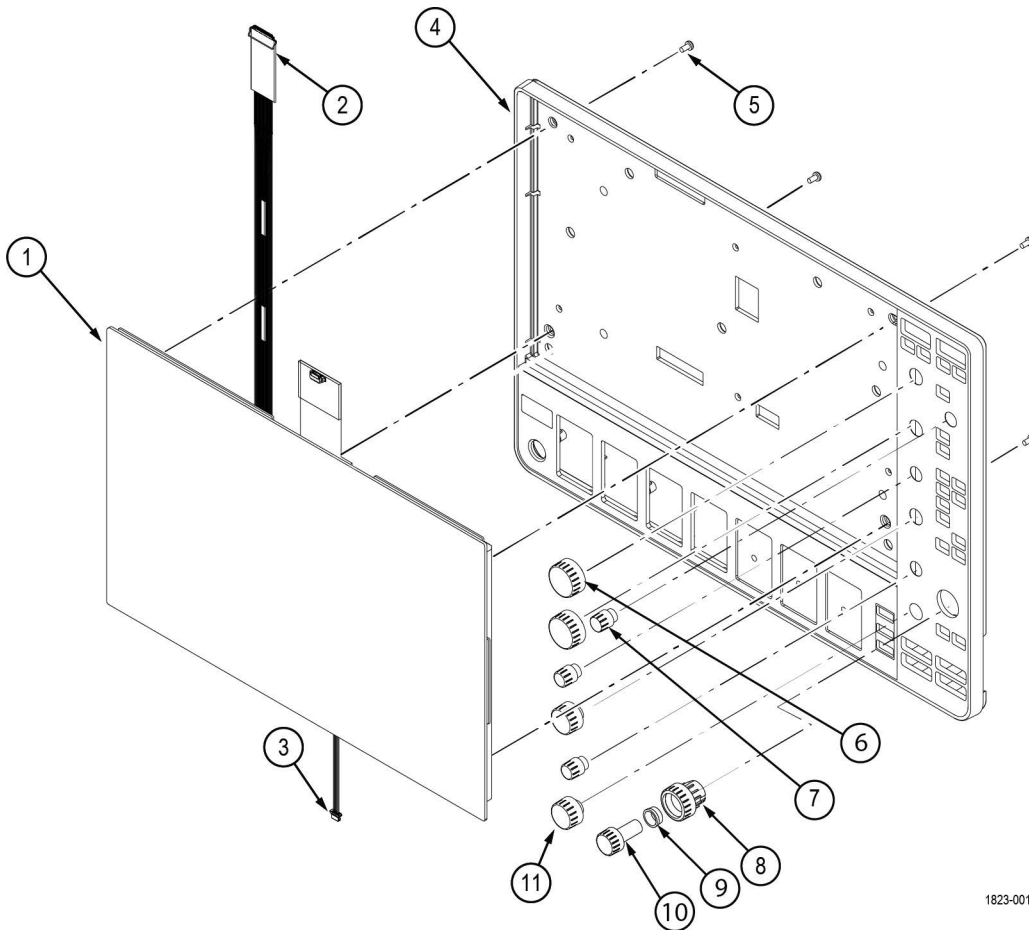

1823-001

Figure 4: Front assembly exploded view

Table 7: Front assembly parts list

Index number	Part number	Serial no. effective	Serial no. discont'd	Qty	Description
-1	065-1098-XX			1	MODULE ASSY: SERVICE REPLACEMENT KIT; TOUCHSCREEN-LCD ASSY WITH DISPLAY BRACKET Return the instrument to Tektronix for service.
-2	174-6610-XX			1	CABLE ASSY, DISPLAY-FRONT PANEL Return the instrument to Tektronix for service.
-3	174-7445-XX			1	CABLE ASSEMBLY, TOUCH SCREEN CONTROLLER 5 PIN Return the instrument to Tektronix for service.
-4	065-1100-XX			1	MSO46B MODULE ASSY: SERVICE REPLACEMENT KIT 6CH FRONT CASE WITH LABELS
	065-1099-XX			1	MSO44B MODULE ASSY: SERVICE REPLACEMENT KIT 4CH FRONT CASE WITH LABELS
-5	211-1584-XX			4	SCREW, MACHINE, M3X0.5X6 MM PAN HEAD, TORX T10
-6	366-0945-XX			1	ASSEMBLY, KNOB, LARGE WITH OVERMOLD
-7	366-0943-XX			1	ASSEMBLY, KNOB, SMALL WITH OVERMOLD
-8	366-0946-XX			1	ASSEMBLY, KNOB, PAN WITH OVERMOLD
-9	358-0890-XX			1	BUSHING, SPACER, RING JOG-SHUTTLE
-10	366-0947-XX			1	ASSEMBLY, KNOB, ZOOM WITH OVERMOLD
-11	366-0944-XX			1	ASSEMBLY, KNOB, MEDIUM WITH OVERMOLD

Rear chassis assembly

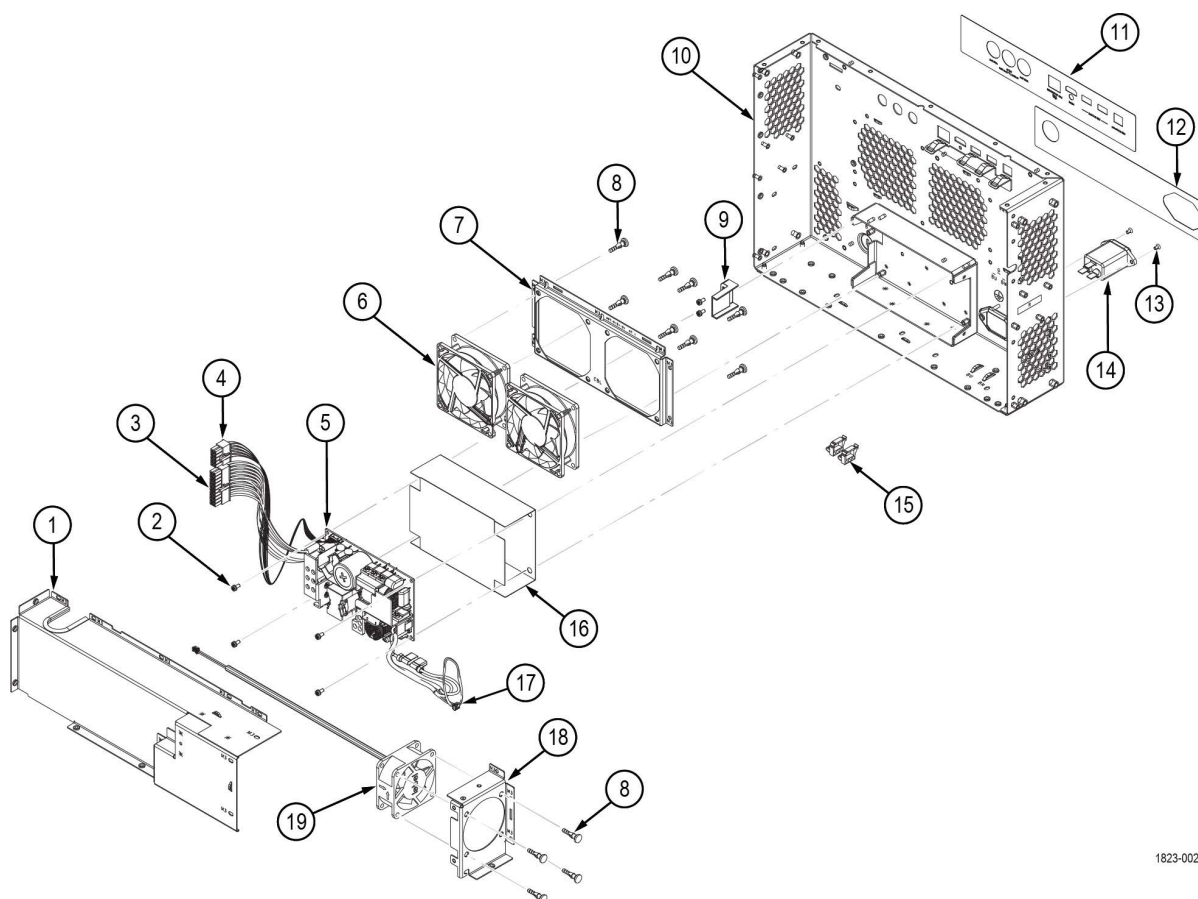

1823-002

Figure 5: Rear chassis assembly exploded view

Table 8: Rear chassis assembly

Index number	Part number	Serial no. effective	Serial no. discont'd	Qty	Description
-1	407-6252-XX			1	BRACKET, POWER SUPPLY
-2	211-1584-XX			6	SCREW, MACHINE, M3X0.5X6MM PAN HEAD, TORX T10
-3	174-7452-XX			1	CABLE, POWER, PWR SUP TO MAIN
-4	174-7454-XX			1	CABLE, PS TO MAIN BOARD, 10 PIN
-5	119-9168-XX			1	POWER SUPPLY: 400W (MAX), AC-DC, OPEN FRAME; 90-264VAC, 47-63 HZ IN; +12V@33.33A, +5V@2A, +12V@0.6A OUT; CN101-JST, WITHOUT SHORTING PLUG, SAFETY CONTROLLED
-6	119-8919-XX			2	FAN ASSEMBLY, SAN ACE 9GA0812P4J0011 W/ TERMINATION, SAFETY CONTROLLED
-7	407-6151-XX			1	BRACKET, 2 FANS
-8	348-2082-XX			12	GROMMET, FAN MOUNT, NOISE DAMPING
-9	220-0346-XX			1	SUPPORT, PS OUT PUT CABLE
-10	441-2957-XX			1	CHASSIS, REAR, SAFETY CONTROLLED

Table continued...

Replaceable parts

Index number	Part number	Serial no. effective	Serial no. discount'd	Qty	Description
-11	335-4598-XX			1	LABEL, REAR, IO, TOP
-12	335-4541-XX			1	LABEL, REAR, IO, BOTTOM
-13	211-1708-XX			2	SCREW, MACHINE, M3 X 0.5 X 5L FLATHEAD 90 DEG, NYLOK, TORX T10
-14	119-8742-XX			1	FILTER, EMI; AC LINE FILTER;10.0A,120-250VAC,DC-400 HZ, IEC INPUT,FAST-ON/SOLDER LUG OUTPUT,CHASSIS MOUNT; FN9244R10-06; SAFETY CONTROLLED
-15	343-1786-XX			2	CABLE CLAMP; WIRE SADDLE, PUSH IN, W/ LOCKING TOP, NYLON 6/6, UL94V-0
-16	337-4895-XX			1	SHIELD, MOUNT, POWER SUPPLY, SAFETY CONTROLLED
-17	174-7406-XX			1	CABLE ASSEMBLY (LINE INPUT)
-18	407-6130-XX			1	BRACKET, POWER SUPPLY, FAN
-19	119-9155-XX			1	FAN WITH 2X1 CONN, 60X25MM, 12V, SAFETY CONTROLLED

Front panel assembly

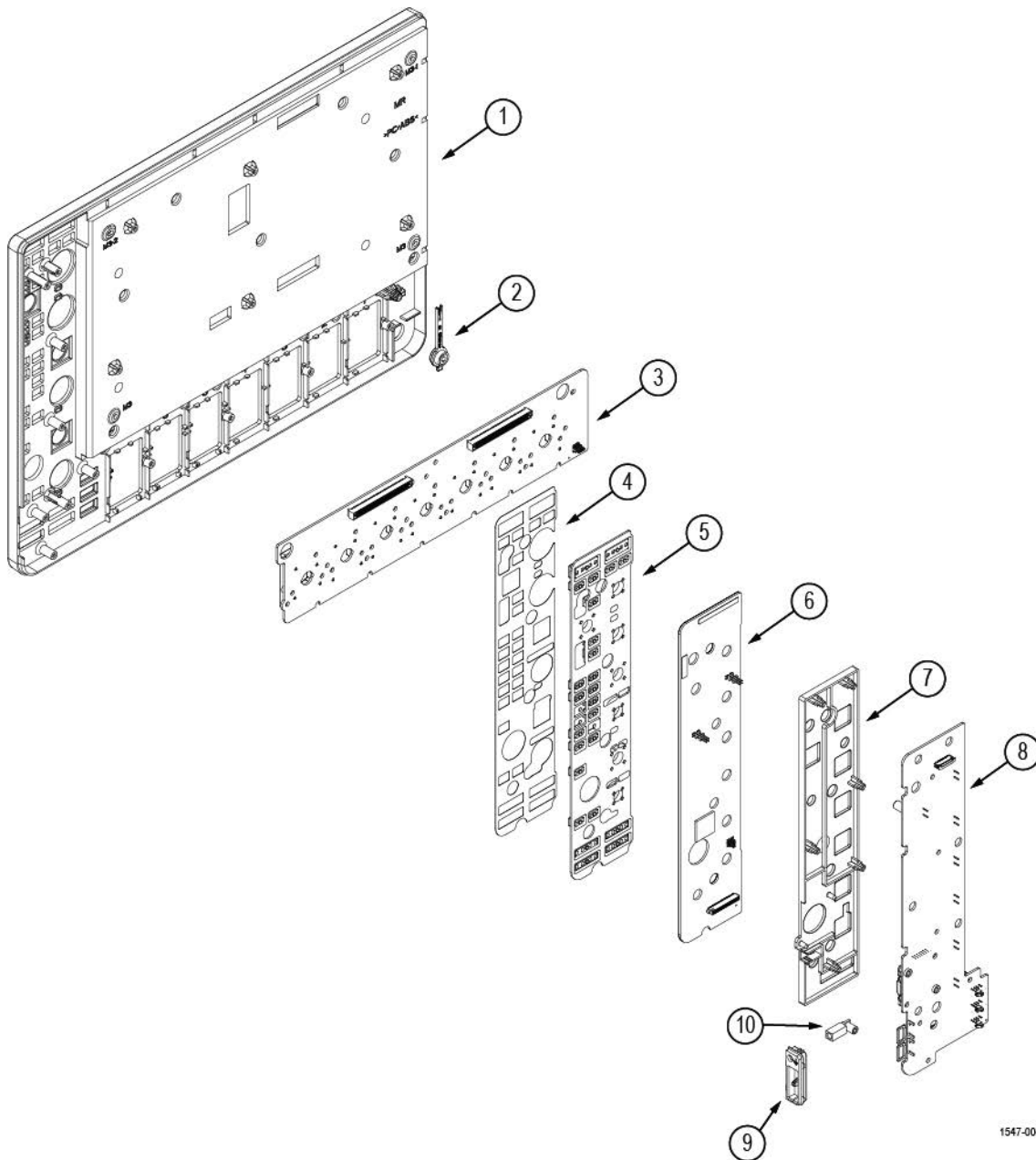

Figure 6: Front panel assembly exploded view



Note: None of the components listed are user-replaceable. Return the instrument to your nearest Tektronix Service Center to repair or replace any internal components or assemblies in this diagram.

Table 9: Front panel assembly

Index number	Part number	Serial no. effective	Serial no. discont'd	Qty	Description
-1	202-0564-XX			1	CASE, FRONT Return the instrument to Tektronix for service.
-2	366-0920-XX			1	BUTTON, POWER SWITCH, SAFETY CONTROLLED Return the instrument to Tektronix for service.
-3	065-1053-XX			1	MSO44B: MODULE ASSY, SERVICE REPLACEMENT KIT, 4CH PROBE INTERFACE WITH VPI BUCKETS Return the instrument to Tektronix for service.
	065-1054-XX			1	MSO46B: MODULE ASSY:SERVICE REPLACEMENT KIT; 6CH PROBE INTERFACE WITH VPI BUCKETS Return the instrument to Tektronix for service.
-4	335-4073-XX			1	LABEL, BLACKOUT, EMAT OVERLAY Return the instrument to Tektronix for service.
-5	260-3144-XX			1	SWITCH, KEYPAD, ELASTOMERIC Return the instrument to Tektronix for service.
-6	065-1094-XX			1	MODULE ASSY: SERVICE REPLACEMENT KIT FRONT PANEL LED (8781899XX) W/ FLEX DOME ARRAY (2590245XX) Return the instrument to Tektronix for service.
-7	361-1890-XX			1	SPACER, FRONT PANEL Return the instrument to Tektronix for service.
-8	878-1584-XX			1	CIRCUIT BOARD ASSY, FRONT PANEL ENCODER 4CH/6CH, 389-5341-XX Return the instrument to Tektronix for service.
-9	380-1322-XX			1	HOUSING, PROBE COMP Return the instrument to Tektronix for service.
-10	131-9410-XX			1	CONNECTOR, RECEPTACLE, GROUND JACK Return the instrument to Tektronix for service.

Front chassis assembly

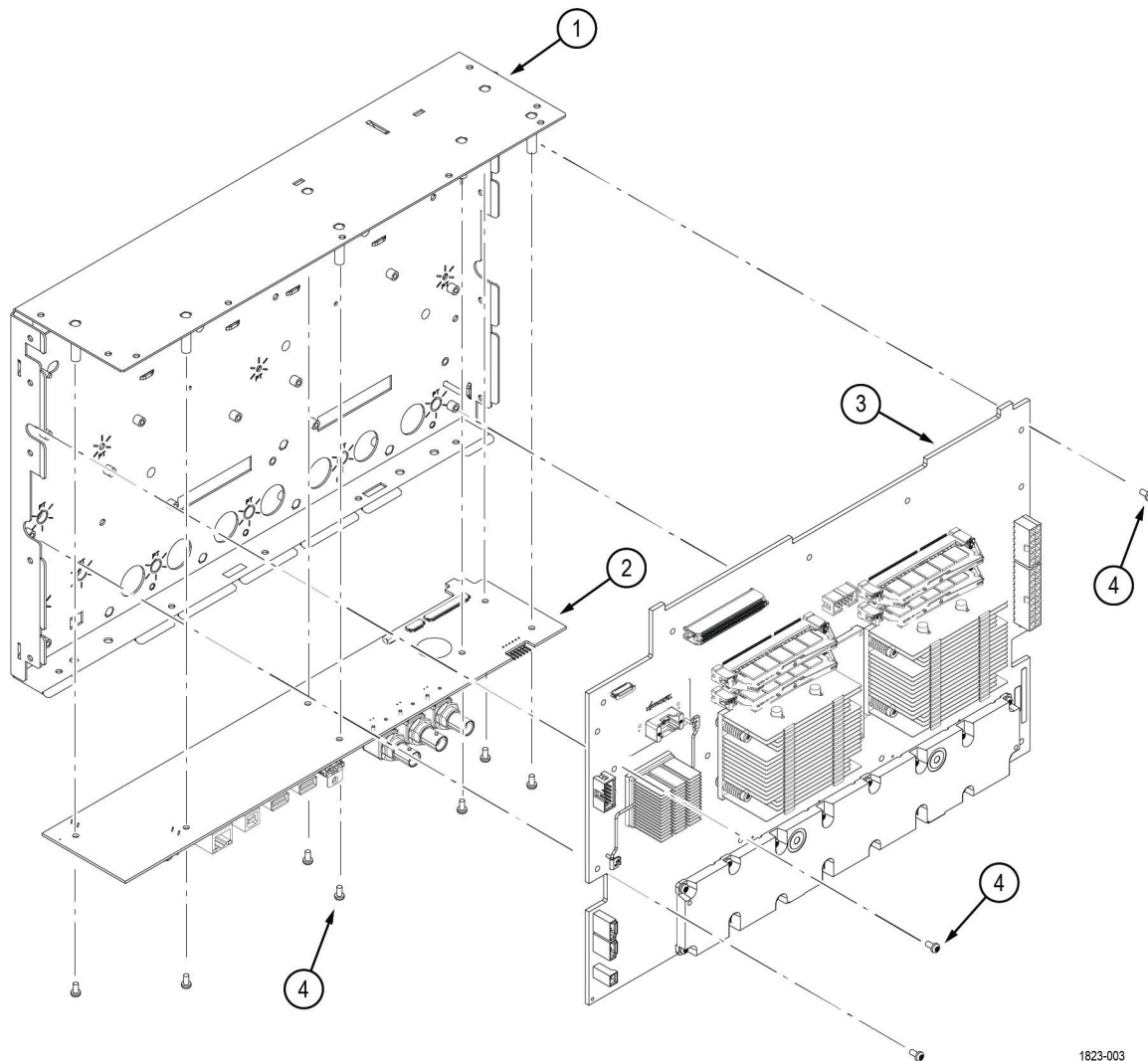

1823-003

Figure 7: Front chassis assembly exploded view



Note: None of the components listed are user-replaceable. Return the instrument to your nearest Tektronix Service Center to repair or replace any internal components or assemblies in this diagram.

Table 10: Front chassis assembly

Index number	Part number	Serial no. effective	Serial no. discont'd	Qty	Description
-1	441-2959-XX			1	CHASSIS, FRONT, ASSEMBLY, SAFETY CONTROLLED Return the instrument to Tektronix for service.
-2	878-1928-XX			1	CIRCUIT BOARD ASSY; PROCESSOR BOARD, 3895672XX Return the instrument to Tektronix for service.

Table continued...

Replaceable parts

Index number	Part number	Serial no. effective	Serial no. discount'd	Qty	Description
-3	878-1937-XX			1	MSO46B: CIRCUIT BOARD ASSY; 6 CH MAIN, 3895679XX Return the instrument to Tektronix for service.
	878-1938-XX			1	MSO44B: CIRCUIT BOARD ASSY; 4 CH MAIN, 3895679XX Return the instrument to Tektronix for service.
-4	211-1584-XX			10	SCREW, MACHINE, M3X0.5X6 MM PAN HEAD, TORX T10