

---

Instruction Manual

**Model 7016A**  
50 $\Omega$  2GHz Multiplexer Card

Contains Operating and Servicing Information

**KEITHLEY**

# WARRANTY

Keithley Instruments, Inc. warrants this product to be free from defects in material and workmanship for a period of 1 year from date of shipment.

Keithley Instruments, Inc. warrants the following items for 90 days from the date of shipment: probes, cables, rechargeable batteries, diskettes, and documentation.

During the warranty period, we will, at our option, either repair or replace any product that proves to be defective.

To exercise this warranty, write or call your local Keithley representative, or contact Keithley headquarters in Cleveland, Ohio. You will be given prompt assistance and return instructions. Send the product, transportation prepaid, to the indicated service facility. Repairs will be made and the product returned, transportation prepaid. Repaired or replaced products are warranted for the balance of the original warranty period, or at least 90 days.

## LIMITATION OF WARRANTY

This warranty does not apply to defects resulting from product modification without Keithley's express written consent, or misuse of any product or part. This warranty also does not apply to fuses, software, non-rechargeable batteries, damage from battery leakage, or problems arising from normal wear or failure to follow instructions.

THIS WARRANTY IS IN LIEU OF ALL OTHER WARRANTIES, EXPRESSED OR IMPLIED, INCLUDING ANY IMPLIED WARRANTY OF MERCHANTABILITY OR FITNESS FOR A PARTICULAR USE. THE REMEDIES PROVIDED HEREIN ARE BUYER'S SOLE AND EXCLUSIVE REMEDIES.

NEITHER KEITHLEY INSTRUMENTS, INC. NOR ANY OF ITS EMPLOYEES SHALL BE LIABLE FOR ANY DIRECT, INDIRECT, SPECIAL, INCIDENTAL OR CONSEQUENTIAL DAMAGES ARISING OUT OF THE USE OF ITS INSTRUMENTS AND SOFTWARE EVEN IF KEITHLEY INSTRUMENTS, INC., HAS BEEN ADVISED IN ADVANCE OF THE POSSIBILITY OF SUCH DAMAGES. SUCH EXCLUDED DAMAGES SHALL INCLUDE, BUT ARE NOT LIMITED TO: COSTS OF REMOVAL AND INSTALLATION, LOSSES SUSTAINED AS THE RESULT OF INJURY TO ANY PERSON, OR DAMAGE TO PROPERTY.



**Keithley Instruments, Inc.** • 28775 Aurora Road • Cleveland, OH 44139 • 440-248-0400 • Fax: 440-248-6168 • <http://www.keithley.com>

<b>BELGIUM:</b>	<b>Keithley Instruments B.V.</b>	Bergensesteenweg 709 • B-1600 Sint-Pieters-Leeuw • 02/363 00 40 • Fax: 02/363 00 64
<b>CHINA:</b>	<b>Keithley Instruments China</b>	Yuan Chen Xin Building, Room 705 • 12 Yumin Road, Dewai, Madian • Beijing 100029 • 8610-62022886 • Fax: 8610-62022892
<b>FRANCE:</b>	<b>Keithley Instruments Sarl</b>	B.P. 60 • 3, allée des Garays • 91122 Palaiseau Cédex • 01 64 53 20 20 • Fax: 01 60 11 77 26
<b>GERMANY:</b>	<b>Keithley Instruments GmbH</b>	Landsberger Strasse 65 • D-82110 Germering • 089/84 93 07-40 • Fax: 089/84 93 07-34
<b>GREAT BRITAIN:</b>	<b>Keithley Instruments Ltd</b>	The Minster • 58 Portman Road • Reading, Berkshire RG30 1EA • 0118-9 57 56 66 • Fax: 0118-9 59 64 69
<b>INDIA:</b>	<b>Keithley Instruments GmbH</b>	Flat 2B, WILOCRISSA • 14, Rest House Crescent • Bangalore 560 001 • 91-80-509-1320/21 • Fax: 91-80-509-1322
<b>ITALY:</b>	<b>Keithley Instruments s.r.l.</b>	Viale S. Gimignano, 38 • 20146 Milano • 02/48 30 30 08 • Fax: 02/48 30 22 74
<b>NETHERLANDS:</b>	<b>Keithley Instruments B.V.</b>	Postbus 559 • 4200 AN Gorinchem • 0183-635333 • Fax: 0183-630821
<b>SWITZERLAND:</b>	<b>Keithley Instruments SA</b>	Kriesbachstrasse 4 • 8600 Dübendorf • 01-821 94 44 • Fax: 01-820 30 81
<b>TAIWAN:</b>	<b>Keithley Instruments Taiwan</b>	1 Fl. 85 Po Ai Street • Hsinchu, Taiwan, R.O.C. • 886-3572-9077 • Fax: 886-3572-9031

# Model 7016A 50 $\Omega$ 2GHz Multiplexer Card Instruction Manual

©1999, Keithley Instruments, Inc.  
All rights reserved.  
Cleveland, Ohio, U.S.A.  
First Printing, May 1999  
Document Number: 7016A-901-01 Rev. A

# Manual Print History

The print history shown below lists the printing dates of all Revisions and Addenda created for this manual. The Revision Level letter increases alphabetically as the manual undergoes subsequent updates. Addenda, which are released between Revisions, contain important change information that the user should incorporate immediately into the manual. Addenda are numbered sequentially. When a new Revision is created, all Addenda associated with the previous Revision of the manual are incorporated into the new Revision of the manual. Each new Revision includes a revised copy of this print history page.

Revision A (Document Number (7016A-901-01) ..... May 1999

# Safety Precautions

---

The following safety precautions should be observed before using this product and any associated instrumentation. Although some instruments and accessories would normally be used with non-hazardous voltages, there are situations where hazardous conditions may be present.

This product is intended for use by qualified personnel who recognize shock hazards and are familiar with the safety precautions required to avoid possible injury. Read the operating information carefully before using the product.

The types of product users are:

**Responsible body** is the individual or group responsible for the use and maintenance of equipment, for ensuring that the equipment is operated within its specifications and operating limits, and for ensuring that operators are adequately trained.

**Operators** use the product for its intended function. They must be trained in electrical safety procedures and proper use of the instrument. They must be protected from electric shock and contact with hazardous live circuits.

**Maintenance personnel** perform routine procedures on the product to keep it operating, for example, setting the line voltage or replacing consumable materials. Maintenance procedures are described in the manual. The procedures explicitly state if the operator may perform them. Otherwise, they should be performed only by service personnel.

**Service personnel** are trained to work on live circuits, and perform safe installations and repairs of products. Only properly trained service personnel may perform installation and service procedures.

Exercise extreme caution when a shock hazard is present. Lethal voltage may be present on cable connector jacks or test fixtures. The American National Standards Institute (ANSI) states that a shock hazard exists when voltage levels greater than 30V RMS, 42.4V peak, or 60VDC are present. **A good safety practice is to expect that hazardous voltage is present in any unknown circuit before measuring.**

Users of this product must be protected from electric shock at all times. The responsible body must ensure that users are prevented access and/or insulated from every connection point. In some cases, connections must be exposed to potential human contact. Product users in these circumstances must be trained to protect themselves from the risk of electric shock. If the circuit is capable of operating at or above 1000 volts, **no conductive part of the circuit may be exposed.**

As described in the International Electrotechnical Commission (IEC) Standard IEC 664, digital multimeter measuring circuits (e.g., Keithley Models 175A, 199, 2000, 2001, 2002, and 2010) are Installation Category II. All other instruments' signal terminals are Installation Category I and must not be connected to mains.

Do not connect switching cards directly to unlimited power circuits. They are intended to be used with impedance limited sources. NEVER connect switching cards directly to AC mains. When connecting sources to switching cards, install protective devices to limit fault current and voltage to the card.

Before operating an instrument, make sure the line cord is connected to a properly grounded power receptacle. Inspect the connecting cables, test leads, and jumpers for possible wear, cracks, or breaks before each use.

For maximum safety, do not touch the product, test cables, or any other instruments while power is applied to the circuit under test. ALWAYS remove power from the entire test system and discharge any capacitors before: connecting or disconnecting cables or jumpers, installing or removing switching cards, or making internal changes, such as installing or removing jumpers.

Do not touch any object that could provide a current path to the common side of the circuit under test or power line (earth) ground. Always make measurements with dry hands while standing on a dry, insulated surface capable of withstanding the voltage being measured.

The instrument and accessories must be used in accordance with its specifications and operating instructions or the safety of the equipment may be impaired.

Do not exceed the maximum signal levels of the instruments and accessories, as defined in the specifications and operating information, and as shown on the instrument or test fixture panels, or switching card.

When fuses are used in a product, replace with same type and rating for continued protection against fire hazard.

Chassis connections must only be used as shield connections for measuring circuits, NOT as safety earth ground connections.

If you are using a test fixture, keep the lid closed while power is applied to the device under test. Safe operation requires the use of a lid interlock.

If a  screw is present, connect it to safety earth ground using the wire recommended in the user documentation.

The  symbol on an instrument indicates that the user should refer to the operating instructions located in the manual.

The  symbol on an instrument shows that it can source or measure 1000 volts or more, including the combined effect of normal and common mode voltages. Use standard safety precautions to avoid personal contact with these voltages.

The **WARNING** heading in a manual explains dangers that might result in personal injury or death. Always read the associated information very carefully before performing the indicated procedure.

The **CAUTION** heading in a manual explains hazards that could damage the instrument. Such damage may invalidate the warranty.

Instrumentation and accessories shall not be connected to humans.

Before performing any maintenance, disconnect the line cord and all test cables.

To maintain protection from electric shock and fire, replacement components in mains circuits, including the power transformer, test leads, and input jacks, must be purchased from Keithley Instruments. Standard fuses, with applicable national safety approvals, may be used if the rating and type are the same. Other components that are not safety related may be purchased from other suppliers as long as they are equivalent to the original component. (Note that selected parts should be purchased only through Keithley Instruments to maintain accuracy and functionality of the product.) If you are unsure about the applicability of a replacement component, call a Keithley Instruments office for information.

To clean an instrument, use a damp cloth or mild, water based cleaner. Clean the exterior of the instrument only. Do not apply cleaner directly to the instrument or allow liquids to enter or spill on the instrument. Products that consist of a circuit board with no case or chassis (e.g., data acquisition board for installation into a computer) should never require cleaning if handled according to instructions. If the board becomes contaminated and operation is affected, the board should be returned to the factory for proper cleaning/servicing.

# 7016A 50Ω 2GHz Multiplexer

**MULTIPLEXERS PER CARD:** 2 (with isolated ground).

**CHARACTERISTIC IMPEDANCE:** 50Ω nominal.

**CHANNELS PER MULTIPLEXER:** 4.

**CONTACT CONFIGURATION:** 1 pole Form A common shield.

**RELAY DRIVE CURRENT:** 120mA.

**CONNECTOR TYPE:** SMA.

**RECOMMENDED CABLE:** RG-223/U.

**TERMINATION:** User supplied 50Ω SMB termination (on unselected inputs).

**ACTUATION TIME:** 8ms.

**MAXIMUM VOLTAGE:** Any terminal (center or shield) to any other center or chassis: 30V.

**MAXIMUM CARRY CURRENT:** 0.5A.

**MAXIMUM CARRY POWER:** 10VA up to 900MHz, 3VA @ 2GHz.

**ISOLATION:**

**Multiplexer to Multiplexer:** >1GΩ.

**Center to Shield:** >1GΩ, <50pF.

**Channel to Channel:** >100MΩ.

**RISE TIME:** <200ps.

**SIGNAL DELAY:** <3ns; channels matched to 50ps.

**CONTACT POTENTIAL:** <6μV.

**CONTACT RESISTANCE:** 0.5Ω.

**CONTACT LIFE:** 3×10<sup>5</sup> @ 30V @ 10mA.  
3×10<sup>5</sup> @ 900MHz, 1W.  
1×10<sup>6</sup> @ cold switching.

**ENVIRONMENT: Operating:** 0° to 50°C; up to 35°C at 80% RH.

**Storage:** -25°C to 65°C.

**EMC:** Conforms with European Union Directive 89/336/EEC.

**SAFETY:** Conforms with European Union Directive 73/23/EEC.

## AC PERFORMANCE:

For $Z_L = Z_S = 50\Omega$	≤10 MHz	≤100 MHz	≤500 MHz	≤1 GHz	≤2 GHz
Insertion Loss (dB):	<0.3	<0.6	<1.0	<1.3	<3.0
Crosstalk (dB): <sup>1</sup>					
Channel-Channel	<-90	<-80	<-65	<-55	<-45
Switch-Switch	<-90	<-80	<-70	<-65	<-45
VSWR	<1.06	<1.1	<1.2	<1.6	≤1.9

<sup>1</sup> Specification assumes 50Ω termination.

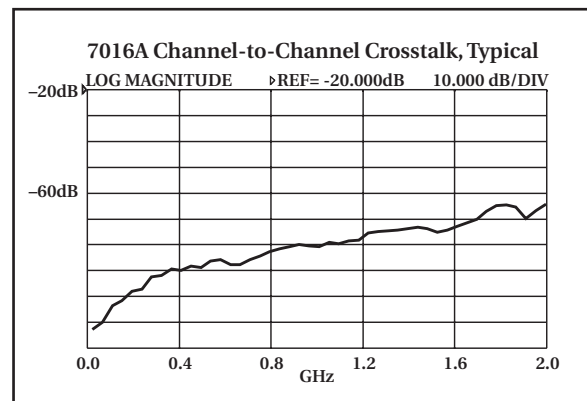
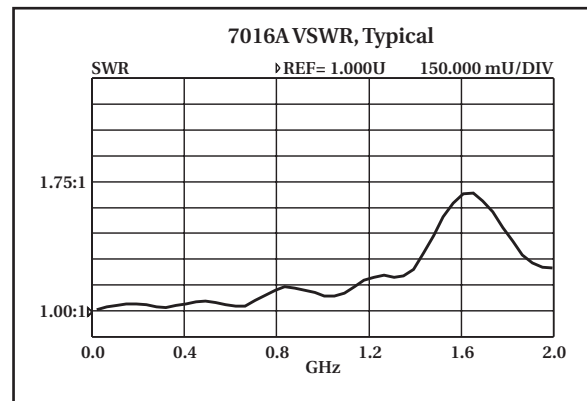
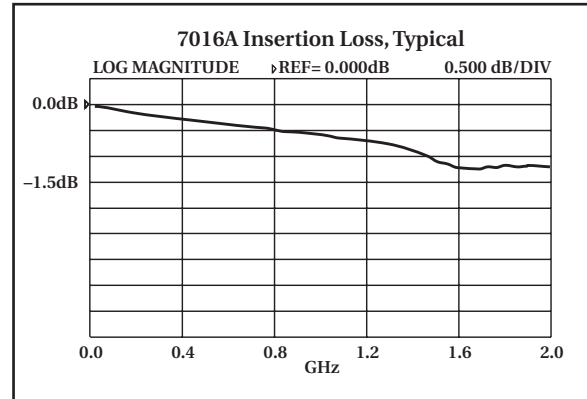
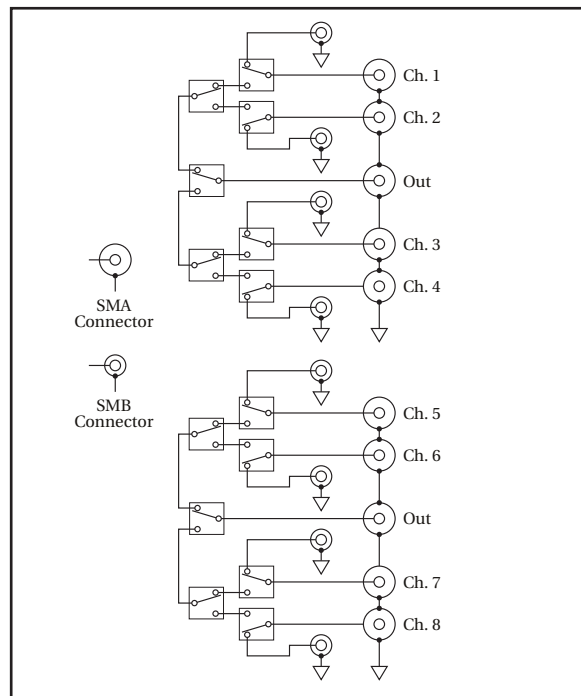

**TYPICAL:** Typical but not warranted parameter, intended to provide useful information for switch application.

# Table of Contents

---

## 1 General Information

1.1	Introduction .....	1-1
1.2	Features .....	1-1
1.3	Warranty information .....	1-1
1.4	Manual addenda .....	1-1
1.5	Safety symbols and terms .....	1-1
1.6	Specifications .....	1-1
1.7	Unpacking and inspection .....	1-2
1.7.1	Inspection for damage .....	1-2
1.7.2	Handling precautions .....	1-2
1.7.3	Shipment contents .....	1-2
1.8	Instruction manual .....	1-2
1.9	Repacking for shipment .....	1-2
1.10	Recommended accessories .....	1-2
1.10.1	Connecting cables .....	1-2
1.10.2	Terminating resistors .....	1-2

## 2 Connections and Installation

2.1	Introduction .....	2-1
2.2	Handling precautions .....	2-1
2.3	Connections .....	2-1
2.3.1	Simplified schematic .....	2-1
2.3.2	Card configuration .....	2-1
2.3.3	Input/output connecting cables .....	2-3
2.3.4	Typical connecting scheme .....	2-3
2.3.5	Input termination .....	2-4
2.4	Card installation and removal .....	2-4
2.4.1	Card installation .....	2-5
2.4.2	Card removal .....	2-5

## 3 Operation

3.1	Introduction .....	3-1
3.2	Signal limitations .....	3-1
3.3	Front panel control .....	3-1
3.3.1	Closing and opening channels .....	3-1
3.3.2	Scanning channels .....	3-2
3.4	IEEE-488 bus control .....	3-2
3.4.1	Closing and opening channels .....	3-2
3.4.2	Scanning channels .....	3-2



3.5	Switching considerations .....	3-2
3.5.1	Card characteristics .....	3-2
3.5.2	Cable characteristics .....	3-3
3.6	Applications .....	3-3
3.6.1	Multiplexer expansion .....	3-3
3.6.2	Filter testing .....	3-4
3.6.3	Impedance testing .....	3-6

## 4 Service Information

4.1	Introduction .....	4-1
4.2	Handling and cleaning precautions .....	4-1
4.2.1	Handling precautions .....	4-1
4.2.2	Soldering considerations .....	4-1
4.3	Performance verification .....	4-1
4.3.1	Environmental conditions .....	4-2
4.3.2	Recommended verification equipment .....	4-2
4.3.3	Insertion loss tests .....	4-2
4.3.4	Isolation tests .....	4-3
4.3.5	Special handling of static-sensitive devices .....	4-7
4.4	Principles of operation .....	4-7
4.4.1	Block diagram .....	4-7
4.4.2	Relay control .....	4-8
4.4.3	Switching circuits .....	4-8
4.4.4	Card configuration memory .....	4-8
4.5	Troubleshooting .....	4-8
4.5.1	Troubleshooting equipment .....	4-8
4.5.2	Troubleshooting procedure .....	4-8

## 5 Replaceable Parts

5.1	Introduction .....	5-1
5.2	Parts list .....	5-1
5.3	Ordering information .....	5-1
5.4	Factory service .....	5-1
5.5	Component layout and schematic diagram .....	5-1

# List of Illustrations

---

## 2 Connections and Installation

Figure 2-1	Model 7016A simplified schematic .....	2-2
Figure 2-2	Model 7016A configuration .....	2-2
Figure 2-3	Typical connection scheme .....	2-3
Figure 2-4	50Ω terminator installation .....	2-4
Figure 2-5	Card installation in Model 7001 .....	2-5
Figure 2-6	Card installation in Model 7002 .....	2-6

## 3 Operation

Figure 3-1	“T” connector multiplexer expansion .....	3-4
Figure 3-2	4 × 4 matrix connections .....	3-5
Figure 3-3	Filter testing .....	3-6
Figure 3-4	Impedance testing .....	3-7

## 4 Service Information

Figure 4-1	Connections for insertion loss tests .....	4-3
Figure 4-2	Connections for channel isolation tests .....	4-4
Figure 4-3	Connections for center-to-shield isolation tests .....	4-5
Figure 4-4	Connections for multiplexer-to-multiplexer isolation tests .....	4-6
Figure 4-5	Block diagram .....	4-7

# List of Tables

---

## **4 Service Information**

Table 4-1	Recommended verification equipment .....	4-2
Table 4-2	Insertion loss values .....	4-2
Table 4-3	Recommended troubleshooting equipment.....	4-8
Table 4-4	Troubleshooting procedure .....	4-8

## **5 Replaceable Parts**

Table 5-1	Model 7016A parts list.....	5-2
-----------	-----------------------------	-----

# General Information

---

## 1.1 Introduction

This section contains general information about the Model 701A6 50 $\Omega$  2GHz Multiplexer Card. The Model 7016A is equipped with two four-channel multiplexers and is designed for 50 $\Omega$  operation. Provisions for user-supplied 50 $\Omega$  terminators are provided on the card.

## 1.2 Features

Key Model 7016A features include:

- Two independent multiplexers each with four channels.
- 50 $\Omega$  characteristic impedance.
- Provisions for user-supplied SMB terminators to maintain nominal 50 $\Omega$  characteristic impedance for off channels.
- 2GHz bandwidth.
- Low insertion loss (<3dB @ 2GHz).
- Low VSWR assures good high-frequency performance.

## 1.3 Warranty information

Warranty information is located on the inside front cover of this instruction manual. Should your Model 7016A require warranty service, contact the Keithley representative or authorized repair facility in your area for further information. When returning the card for repair, be sure to fill out and include the service form at the back of this manual in order to provide the repair facility with the necessary information.

## 1.4 Manual addenda

Any improvements or changes concerning the card or manual will be explained in an addendum included with the card.

## 1.5 Safety symbols and terms

The following symbols and terms may be found on an instrument or used in this manual.

The  symbol on equipment indicates that you should refer to the operating instructions located in the instruction manual.

The **WARNING** heading used in this manual explains dangers that might result in personal injury or death. Always read the associated information very carefully before performing the indicated procedure.

The **CAUTION** heading used in this manual explains hazards that could damage the multiplexer card. Such damage may invalidate the warranty.

## 1.6 Specifications

Model 7016A specifications are located at the front of this manual.

## 1.7 Unpacking and inspection

### 1.7.1 Inspection for damage

The Model 7016A is packaged in a re-sealable, anti-static bag to protect it from damage due to static discharge and from contamination that could degrade its performance. Before removing the card from the bag, observe the precautions on handling discussed below.

### 1.7.2 Handling precautions

- Always grasp the card by the side edges and covers. Do not touch the board surfaces or components.
- After removing the card from its anti-static bag, inspect it for any obvious signs of physical damage. Report any such damage to the shipping agent immediately.
- When the card is not installed in a switching mainframe, keep the card in its anti-static bag, and store it in the original packing carton.

### 1.7.3 Shipment contents

The following items are included with every Model 7016A order:

- Model 7016A 50 $\Omega$  2GHz Multiplexer Card
- Model 7016A Instruction Manual
- Additional accessories as ordered

## 1.8 Instruction manual

If an additional Model 7016A Instruction Manual is required, order the manual package, Keithley part number 7016A-901-00. The manual package includes an instruction manual and any pertinent addenda.

## 1.9 Repacking for shipment

Should it become necessary to return the Model 7016A for repair, carefully pack the unit in its original packing carton or the equivalent, and include the following information:

- Advise as to the warranty status of the card.
- Write ATTENTION REPAIR DEPARTMENT on the shipping label.
- Fill out and include the service form located at the back of this manual.

## 1.10 Recommended accessories

Recommended cables and terminating resistors are covered below. These items are not stocked by Keithley and must be obtained from other sources.

### 1.10.1 Connecting cables

The following cable type is recommended for making input/output connections to the Model 7016A: RG223/U.

Other 50 $\Omega$  cables may be used, but keep in mind key parameters as such as maximum outside diameter, attenuation over the desired frequency range, flexibility, and shield type. See paragraph 3.5 in Section 3 for more information on cable parameters.

### 1.10.2 Terminating resistors

The following terminating resistor is recommended for use with the Model 7016A:

**Type:** Plug Dummy Load

**Manufacturer:** Johnson Components

**Part number:** 131-3801-811

**Nominal resistance:** 50 $\Omega$

**Power dissipation:** 2W

# 2

## Connections and Installation

---

### 2.1 Introduction

#### WARNING

The procedures in this section are intended only for qualified service personnel. Do not perform these procedures unless you are qualified to do so. Failure to recognize and observe normal safety precautions could result in personal injury or death.

This section includes information on making connections to the Model 7016A and installing the card in the Model 7001/7002 Switch System.

### 2.2 Handling precautions

To maintain high-impedance isolation between channels, care should be taken when handling the card to avoid contamination from such foreign materials as body oils. Such contamination can reduce isolation resistance. To avoid possible contamination, always grasp the card by the side edges or covers. Do not touch board surfaces, components, or connector insulators.

Dirt build-up over a period of time is another possible source of contamination. To avoid this problem, operate the card in a clean environment. If the card becomes contaminated, it should be thoroughly cleaned as explained in paragraph 4.2.

### 2.3 Connections

This paragraph provides the information necessary to connect your external test circuitry to the Model 7016A.

#### 2.3.1 Simplified schematic

Figure 2-1 shows a simplified schematic diagram of the Model 7016A. The card is arranged into two separate multiplexers, each with four channels.

#### 2.3.2 Card configuration

Figure 2-2 shows the general configuration of the Model 7016A. Connectors include:

**IN 1-8 (channels 1-8):** Each input is equipped with an SMA coaxial connector. The center conductor is the signal path, while the outer shell connected to signal common.

**OUT A and OUT B:** Each multiplexer is equipped with an SMA coaxial connector. The center conductor is the signal path, and the shell is connected to signal common.

**Termination jacks:** Each channel has an SMB coaxial terminator jack. User-supplied  $50\Omega$  terminators can be connected to these jacks when a  $50\Omega$  nominal input impedance must be maintained for off channels.

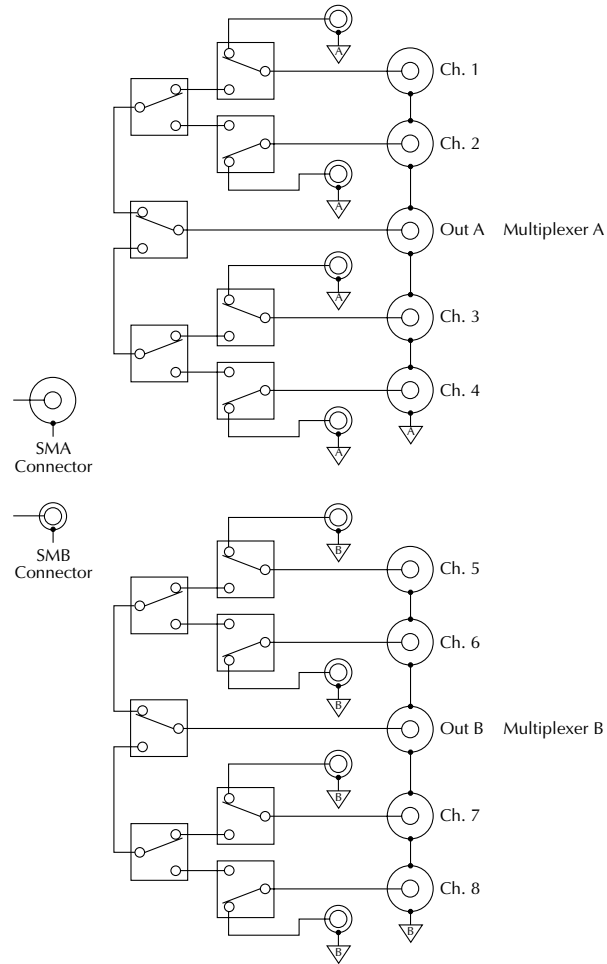

**Figure 2-1**  
Model 7016A simplified schematic

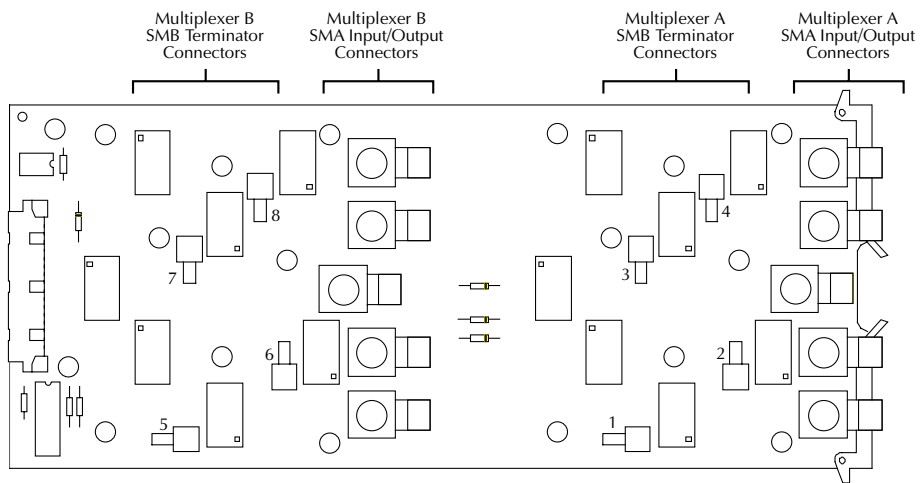

**Figure 2-2**  
Model 7016A configuration

### 2.3.3 Input/output connecting cables

All connections to the scanner card input and output jacks should be made using 50Ω coaxial cable equipped with SMA connectors. The recommended cable type is RG223/U.

**WARNING**

Make sure that power is off and external energy sources are discharged before connecting or disconnecting cables.

**NOTE**

50Ω cables must be used to assure good high-frequency performance. RG223/U should be used for best performance. See paragraph 3.5 in Section 3 for more information.

### 2.3.4 Typical connecting scheme

Figure 2-3 shows a typical connecting scheme for the Model 7016A. In this arrangement, sources are connected to the inputs while the measuring instrument is connected to the outputs.

**CAUTION**

Maximum voltage from any terminal (center conductor or shield) to any other terminal or chassis is 30V RMS. Exceeding this value may result in card damage.

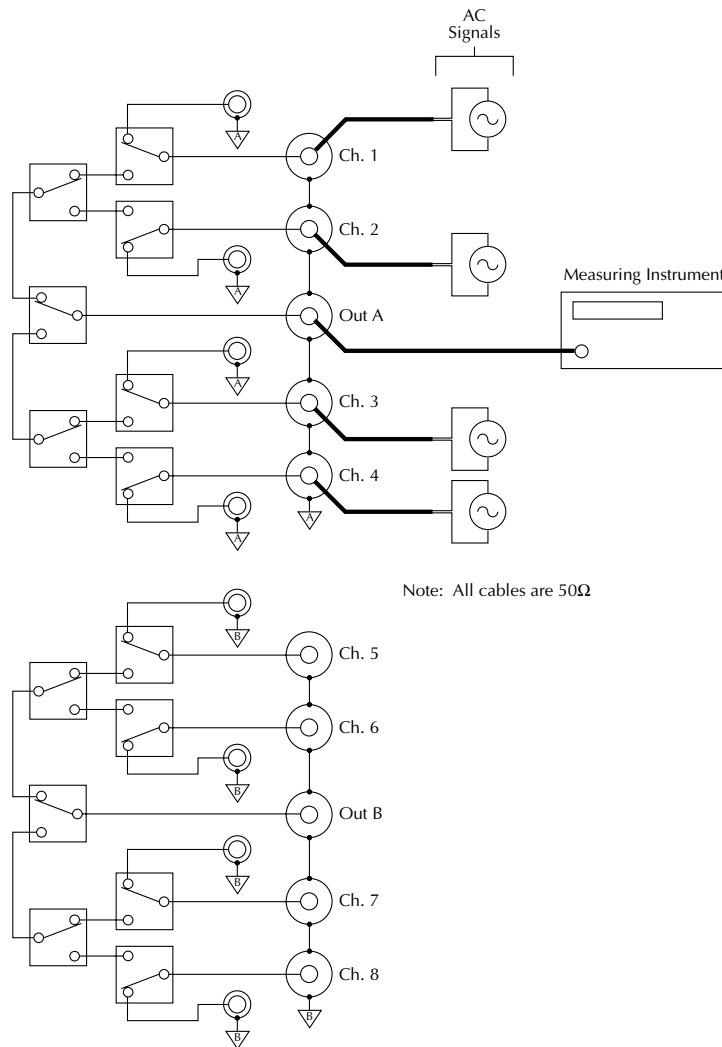

Figure 2-3  
Typical connection scheme



### 2.3.5 Input termination

User-supplied 50Ω female SMB terminators may be installed for applications requiring proper 50Ω termination of off channels. Figure 2-4 shows typical installation of a 50Ω terminator. See paragraph 1.10 in Section 1 for recommended terminators. Switching considerations in Section 3 discusses terminator aspects in more detail.

#### NOTE

Be sure to observe the maximum power handling capability of installed terminators. The terminators recommended in Section 1 are limited to 2W even though the Model 7016A can switch up to 10W.

### 2.4 Card installation and removal

This paragraph explains how to install and remove the Model 7016A card assembly from the Model 7001/7002 main-frame.

#### WARNING

Installation or removal of the Model 7016A should be performed only by qualified service personnel. Failure to recognize and observe standard safety precautions could result in personal injury or death.

#### NOTE

To prevent performance degradation caused by contamination, handle the card only by the edges and covers.

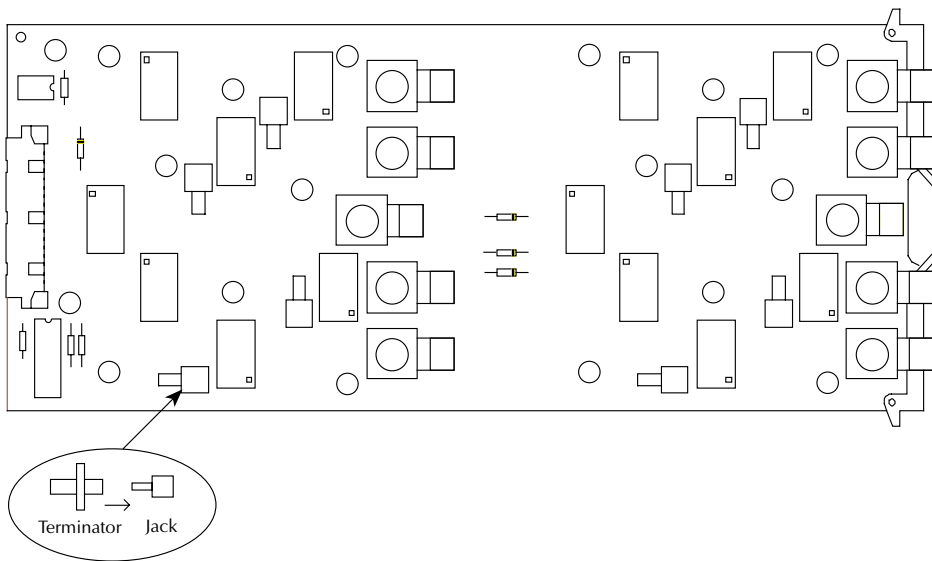

Figure 2-4  
50Ω terminator installation

## 2.4.1 Card installation

Perform the following steps, and refer to Figure 2-5 or Figure 2-6 to install the card assembly in the Model 7001/7002 mainframe.

### WARNING

Turn off power to all instrumentation (including the Model 7001/7002), and disconnect all line cords. Make sure all power is removed and any stored energy in external circuitry is discharged.

1. Open the ejector arms at the back edge of the card.
2. Slide the card edges into the guide rails inside the mainframe.
3. Carefully push the card all the way forward until the ejector arms engage the mounting cups.
4. Push in on the card edge and ejector arms until the card is properly seated.
5. Make sure the ejector arms are properly latched.

## 2.4.2 Card removal

Follow the steps below to remove the multiplexer card from the mainframe:

### WARNING

Turn off power to all instrumentation (including the Model 7001/7002), and disconnect all line cords. Make sure all power is removed and any stored energy in external circuitry is discharged.

1. Pull out on the ejector arms until the card pulls free from the internal connector.
2. Carefully slide the card out of the switching mainframe.

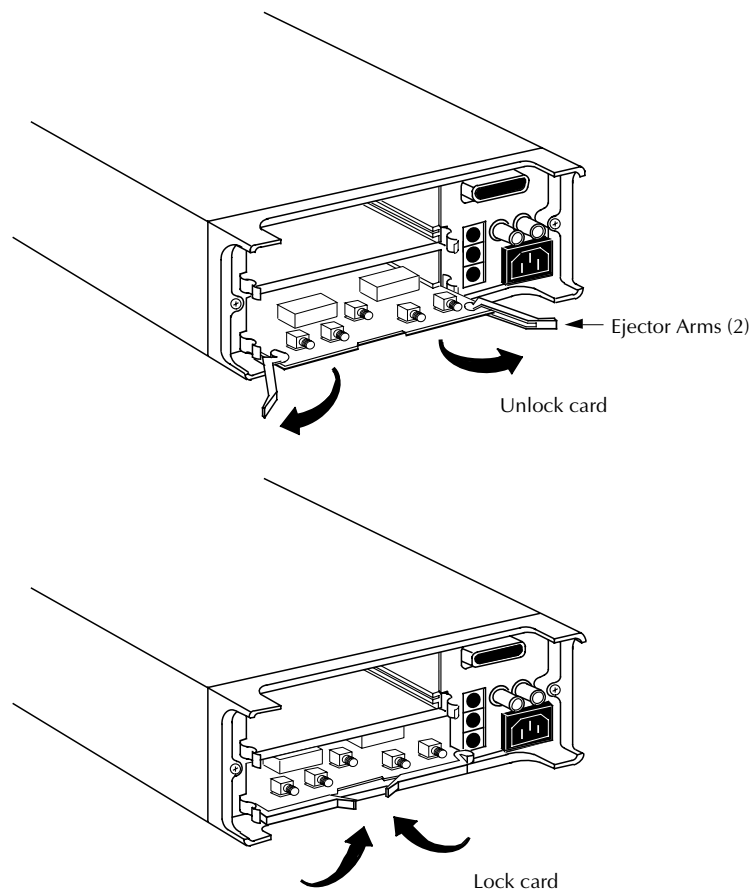

**Figure 2-5**  
Card installation in Model 7001

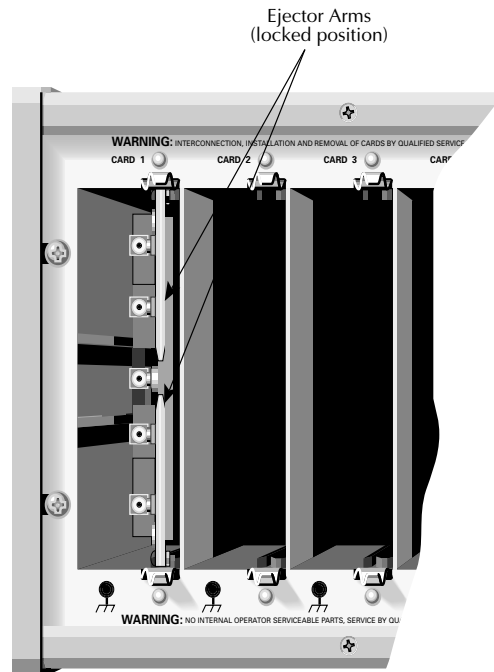

**Figure 2-6**  
*Card installation in Model 7002*

# 3

## Operation

---

### 3.1 Introduction

This section contains basic information on using the Model 7016A including signal limitations and switching considerations. For detailed mainframe operating information, refer to the Model 7001 or Model 7002 Instruction Manual.

### 3.2 Signal limitations

#### CAUTION

To prevent damage to the Model 7016A, do not exceed the maximum signal level specifications of the card.

To prevent over-heating or damage to the relays, never exceed the following maximum signal levels when using the Model 7016A:

- Maximum voltage: Any center conductor or shield to any other center conductor or to chassis: 30V.
- Maximum current: 0.5A per channel.
- Maximum power: 10VA switched up to 900MHz, 3VA @ 2GHz.

### 3.3 Front panel control

#### 3.3.1 Closing and opening channels

To close a Model 7016A multiplexer channel, simply key in the CHANNEL assignment (1-8), then press the Model 7001/7002 CLOSE key. For example, to close channel 4 of a

Model 7016A installed in slot 2, key in the following channel list, and press CLOSE:

```
SELECT CHANNELS 2!4
```

To open a closed channel, simply press OPEN or OPEN ALL.

Channels are organized into two multiplexer banks as follows:

Multiplexer A: channels 1 to 4

Multiplexer B: channels 5 to 8

You can also simultaneously close one channel in each multiplexer by including both channels in the channel list. For example, to close channels 1 and 5 of a card in slot 1, enter the following channel list at the prompt:

```
SELECT CHANNELS 1!1, 1!5
```

(Note that channels are separated by a comma, which can be inserted by pressing either the ENTER or right cursor key.)

#### NOTE

To maintain 50Ω characteristic impedance, close only one channel per multiplexer simultaneously. Closing more than one channel per multiplexer may cause unexpected results. Program the Model 7001/7002 for restricted operation to avoid closing more than one channel at a time.

Again, you can open closed channels with the OPEN or OPEN ALL key. (OPEN opens only channels in the channel list while OPEN ALL opens all channels.)

### 3.3.2 Scanning channels

To scan through channels, first configure a scan list, then program the Model 7001/7002 to perform a scan sequence. You can create a scan list in the same manner as you would a channel list. First, however, press the SCAN LIST key to select the “SCAN CHANNEL” mode, then enter the desired channels to be included in the scan list. For example, the following list scans channels 1, 3, and 5 through 8 of a Model 7016A installed in slot 2:

```
SCAN CHANNELS 2!1, 2!3, 2!5-2!8
```

Note that channels are scanned in the order they appear in the scan list.

To perform a manual scan, first select the RESET default conditions in the SAVESETUP menu of the main MENU. Press STEP to take the mainframe out of the idle state, then manually scan through channels by pressing the STEP key.

For information on more complex scan sequences, refer to the Model 7001 or 7002 Instruction Manual.

## 3.4 IEEE-488 bus control

### 3.4.1 Closing and opening channels

Use the following SCPI commands to close and open channels:

```
:CLOS <list>
:OPEN <list> | ALL
```

For example, the following command will close channels 2 and 6 of a Model 7016A installed in slot 1:

```
:CLOS (@ 1!2, 1!6)
```

Conversely, either of the commands below will open previously closed channels 2 and 6:

```
:OPEN (@ 1!2, 1!6)
:OPEN ALL
```

### 3.4.2 Scanning channels

There are a number of commands associated with scanning. However, you can perform a simple scan using only the following four commands:

```
*RST
:TRIG:SEQ:COUN:AUT ON
:ROUT:SCAN <list>
:INIT
```

The \*RST command selects the default scan configuration, while the second command automatically sets the channel count to the number of channels in the scan list. The :ROUT:SCAN command programs the scan list, and the :INIT command takes the mainframe out of the idle state.

For example, send the following commands to scan through all eight channels of a Model 7016A installed in slot 1:

```
*RST
:TRIG:SEQ:COUN:AUT ON
:ROUT:SCAN (@ 1!1:1!8)
:INIT
```

## 3.5 Switching considerations

Signals passing through the Model 7016A 50Ω 2GHz Multiplexer Card are subject to various effects that can influence their characteristics. The following paragraphs discuss some of these effects and ways to minimize them.

### 3.5.1 Card characteristics

**Insertion loss:** Insertion loss indicates signal power lost while passing through the card. This loss occurs in the various signal path components through the card (connectors, PC board traces, and relays). The amount of power lost will, of course, depend on the particular insertion loss specification as well as the applied power. For example, with an insertion loss of 1dB, and a 10W source signal applied to the card, about 2W will be dissipated in the card, and approximately 8W will appear at the load. Note that, as with most transmission lines, Model 7016A insertion loss values increase with increasing frequency.

**Capacitance:** Model 7016A capacitance values are sufficiently small to be of little concern in most applications. In some applications (primarily with pulse signals where capacitance can affect rise times), capacitance may be a factor. Typical Model 7016A center-to-shield capacitance is 50pF.

**Crosstalk:** Crosstalk figures indicate the amount of signal leakage between channels or switches on the card. With similar power levels applied to the various channels, crosstalk will be of little consequence. With widely different power levels, however, crosstalk may produce undesired results. For example, assume that 10W is applied to channel 1, and 1mW is applied to channel 2. Assuming a -55dB crosstalk figure, the unwanted signal coupled from channel 1 to channel 2 will be only 15dB below the desired channel 2 signal.

**VSWR:** The term VSWR (Voltage Standing Wave Ratio) is defined as the ratio of the maximum and minimum voltages along a transmission path, and it indicates the degree of impedance mismatch. In a perfectly match system, the VSWR is 1, while open and shorted paths have infinite VSWR values. Since VSWR is related to both the return loss and reflection coefficient, VSWR figures indicate the degree of signal loss and reflection; the lower the VSWR figure, the less signal attenuation that occurs along the transmission path.

**Path isolation resistance:** The path isolation resistance is simply the equivalent resistance between two given connecting points on the card and is of importance primarily for DC and low-frequency AC signals switched by the card. The effects of this characteristic depend on the particular isolation specification. Center-to-shield isolation resistance, for example, may cause loading problems with signals having high source resistance. Channel-to-channel isolation resistance may result in leakage currents generated in one channel caused by a voltage source connected to another channel.

### 3.5.2 Cable characteristics

**Characteristic impedance ( $Z_0$ ):** Characteristic impedance is the value of cable impedance obtained by an RF measurement at either end. For example, a cable with a  $50\Omega$  characteristic impedance is equivalent to a  $50\Omega$  resistor with sufficient length to connect two components. (The characteristic impedance of a cable depends on the relative diameters of the inner and outer conductors, as well as on the dielectric constant of the insulating material.) Since the Model 7016A is designed to work with  $50\Omega$  cables, you must use  $50\Omega$  cables to assure proper impedance matching. (RG223/U cable is recommended.) Mismatching anywhere along the transmission path will increase VSWR and signal reflections, decrease return loss, and consequently result in signal attenuation.

**Cable attenuation:** Cable attenuation is analogous to insertion loss of the card itself in that it defines the degree of attenuation of the signal as it passes through the cable. Cable attenuation factors are generally given in dB per 100 ft. and increase with rising frequency. The recommended RG223/U cable has attenuation factors of 8.8dB/100 ft. @ 400MHz and 16.5dB/100 ft. @ 1GHz. Thus, with a 10W, 1GHz signal applied to 10 ft. of RG223/U, 3.16W will be dissipated in the cable, and 6.84W will be passed on to the card or load.

**Cable termination:** Proper cable termination is imperative to ensure maximum signal transfer and to minimize VSWR and signal reflections. In the case of Model 7016A operation, both source and load impedances should be as close to  $50\Omega$  as possible to assure optimum matching and thus maximum

power transfer. For example, if a  $50\Omega$  cable is terminated with  $100\Omega$ , the reflection coefficient is 0.33, the VSWR increases to 2, and the return loss is reduced to less than 10dB.

Proper termination of off channels may also be important in many cases. For example, a 75MHz source signal will see a 1m open cable as an RF short, a situation that could damage some equipment. To alleviate such problems, the Model 7016A has provisions for on-card installation of  $50\Omega$  SMB terminators. (See paragraph 2.3.5 in Section 2 for details on installing terminators.) Be sure to observe the power-handling capabilities of such terminators as most are limited to substantially less power than the 10W capability of the Model 7016A.

**Distributed capacitance:** The distributed capacitance of the cable may be a factor, but generally only for pulse type signals where rise times are a consideration. The recommended RG223/U cable, for example, has a nominal distributed capacitance of 30.8pF/ft.

**Cable connectors:** Cable connectors are an obvious necessity to conveniently make signal connections to various points in a switching system. While connector designs are optimized for best performance, some small impedance mismatch at connecting points is virtually inevitable. For that reason, it is considered good practice to minimize the number of connectors used in a transmission path, especially at higher frequencies.

## 3.6 Applications

The Model 7016A is designed primarily for RF switching applications at frequencies up to 2GHz. The following paragraphs discuss typical RF applications for the Model 7016A, including multiplexer expansion, filter testing, and device impedance testing.

### 3.6.1 Multiplexer expansion

The simplest way to connect the two Model 7016A multiplexers together for expansion is to use the classic "T" configuration shown in Figure 3-1. Note that this configuration results in a 1-of-8 multiplexer. Although this configuration is useful in many applications, the ideal  $50\Omega$  characteristic impedance will not be maintained. Consequently, VSWR will increase, affecting card insertion loss, particularly at higher frequencies. Also, considerable transmission path reflections will occur, an important consideration when switching pulse signals.

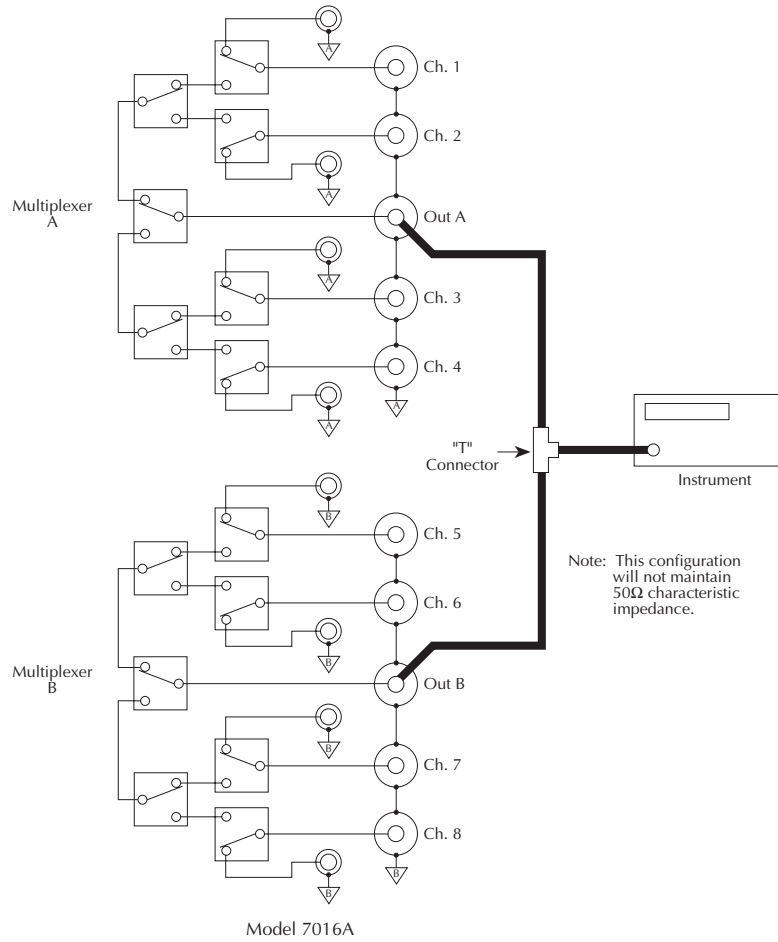

**Figure 3-1**  
*"T" connector multiplexer expansion*

The proper way to connect the two Model 7016A multiplexers together is shown in Figure 3-2. Here, the two outputs are connected together using a short coaxial cable. Note that this connection scheme effectively forms a  $4 \times 4$  matrix, and it

provides a convenient way to connect four DUTs to four different test instruments. Also, this method maintains the proper  $50\Omega$  characteristic impedance for optimum bandwidth and minimal signal loss and reflections.

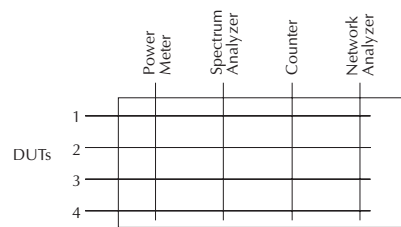
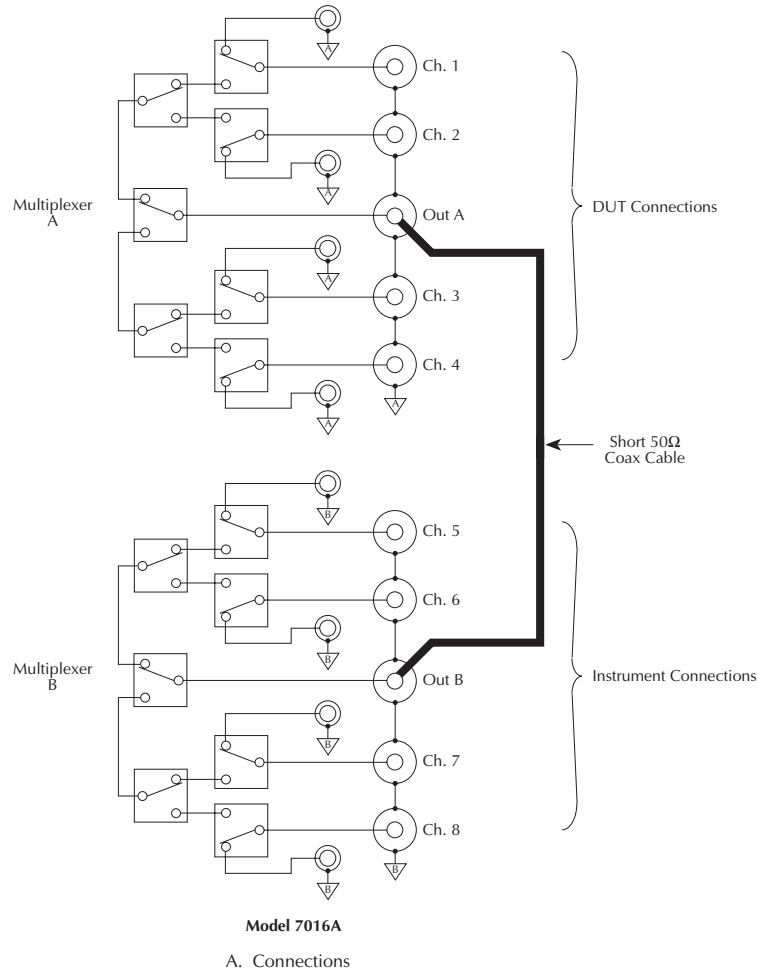

**Figure 3-2**  
 *$4 \times 4$  matrix connections*



### 3.6.2 Filter testing

Filter frequency response and phase characteristics are key circuit parameters that often require testing. The Model 7016A may be used in conjunction with a network analyzer to test multiple filters on an automated basis.

Figure 3-3 shows a typical circuit configuration for testing four filters. Note that the network analyzer input is connected to the output of one Model 7016A multiplexers. One terminal of each DUT is connected to a corresponding Model 7016A channel, while the remaining DUT terminals are connected in common to the network analyzer output port.

The basic configuration shown in Figure 3-3 may also be used for a variety of other tests. For example, the same general scheme may be used to test amplifier S-parameters.

### 3.6.3 Impedance testing

Figure 3-4 shows the general circuit configuration for device impedance testing using the Model 7016A along with an impedance or LCZ meter, such as a Keithley Model 3321, 3322, or 3330. Since 4-wire connections are required for such measurements, two Model 7016A cards are necessary for this application. Each multiplexer switches one of the four required signal paths to the DUTs.

Since the characteristics of the Model 7016A may affect measured DUT impedance, steps should be taken to null out the residual affects of stray capacitance and inductance. Most LCZ meters have provisions for both open and short zeroing procedures to minimize these effects. For optimum accuracy, the zeroing procedure should be carried out independently for each channel.

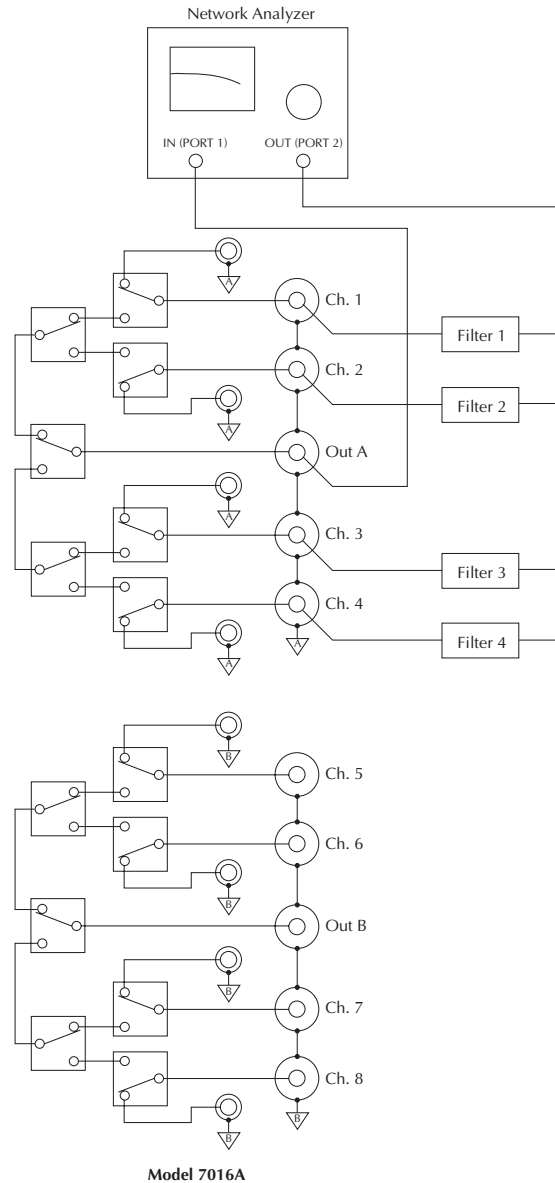

**Figure 3-3**  
Filter testing

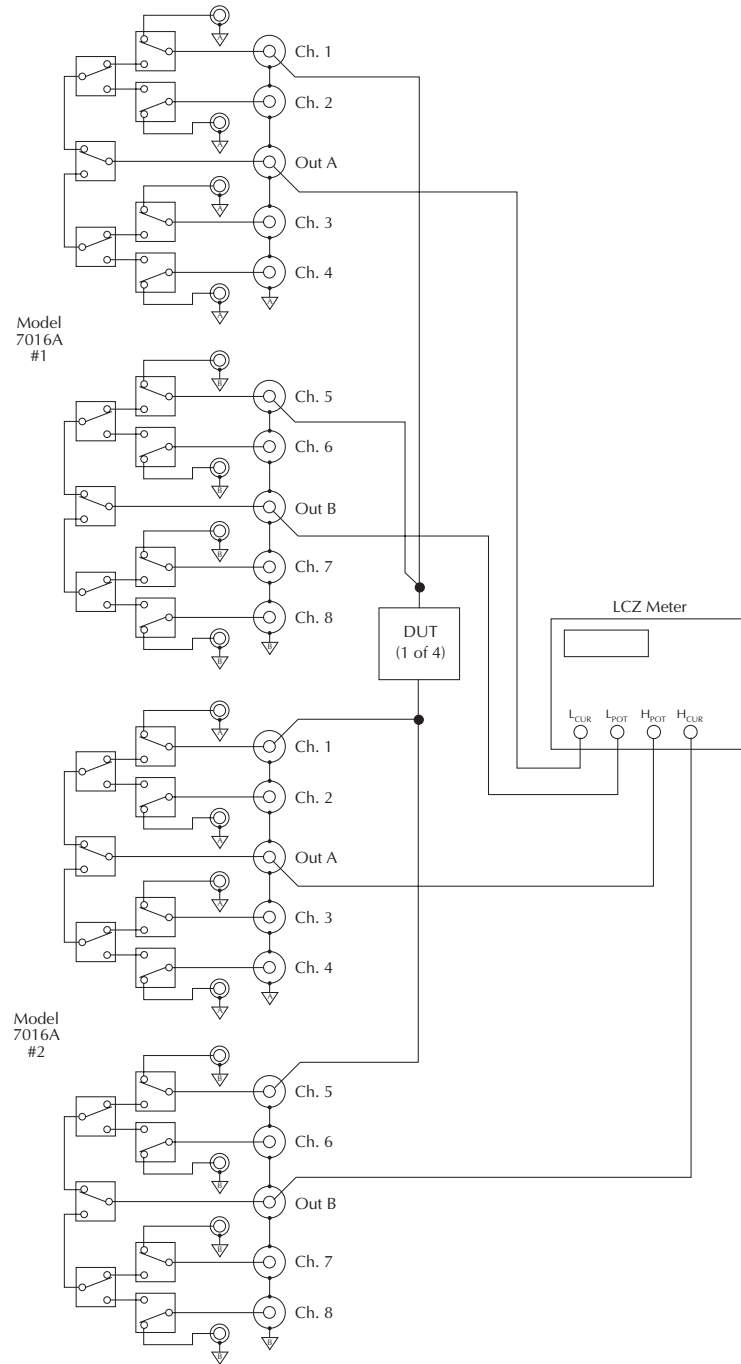

**Figure 3-4**  
Impedance testing

# 4

## Service Information

---

### 4.1 Introduction

This section contains information necessary to service the Model 7016A and includes information on handling and cleaning, performance verification, as well as principles of operation and troubleshooting.

#### WARNING

The information in this section is intended only for qualified service personnel. Some of the procedures may expose you to hazardous voltages that could result in personal injury or death. Do not perform these procedures unless you are qualified to do so.

### 4.2 Handling and cleaning precautions

Because of the high-impedance areas on the Model 7016A, care should be taken when handling or servicing the card to prevent possible contamination. The following precautions should be observed when servicing the card.

#### 4.2.1 Handling precautions

Observe the following precautions when handling the multiplexer card:

- Handle the card only by the edges and shields.
- Do not touch connector insulators.
- Do not touch any board surfaces or components not associated with the repair.

- Do not touch areas adjacent to electrical contacts.
- When servicing the card, wear clean cotton gloves.
- Do not store or operate the card in an environment where dust could settle on the circuit board.
- Use dry nitrogen gas to clean dust off the board if necessary.

#### 4.2.2 Soldering considerations

Should it become necessary to use solder on the circuit board, observe the following precautions:

- Use an OA-based (organic activated) flux, and take care not to spread the flux to other areas of the circuit board.
- Remove the flux from the work areas when the repair has been completed. Use pure water along with clean cotton swabs or a clean soft brush to remove the flux.
- Once the flux has been removed, swab only the repaired area with methanol, then blow dry the board with dry nitrogen gas.
- After cleaning, allow the card to dry in a 50°C low-humidity environment for several hours before use.

### 4.3 Performance verification

The following paragraphs provide performance verification procedures for the Model 7016A. These tests include insertion loss and isolation tests.

### 4.3.1 Environmental conditions

All performance verification measurements should be made at an ambient temperature of 18°C to 28°C and <70% relative humidity.

### 4.3.2 Recommended verification equipment

Table 4-1 summarizes the test equipment recommended for performance verification. Alternate equipment may be used as long as the corresponding specifications are at least as good as those listed.

### 4.3.3 Insertion loss tests

Insertion loss tests are performed by applying a 10MHz-2GHz signal from a network analyzer to the Model 7016A channel inputs and then measuring the amount of attenuation as the signal passes through the card.

Proceed as follows:

1. Set the network analyzer to sweep the 10MHz to 2GHz frequency range.
2. Normalize the analyzer reference channel to 0dB on the display.
3. Connect the network analyzer to the Model 7016A as shown in Figure 4-1. Be sure to use 50Ω cables and set-up for all insertion loss tests.
4. Install the Model 7016A in the Model 7001 or 7002 mainframe.

5. Close channel 1 on the Model 7016A card.
6. Verify that the insertion loss values are within the limits shown in Table 4-2.
7. Open the closed channel.
8. Repeat steps 3 through 7 for channels 2 through 8. For each channel:
  - Connect the analyzer signal to the input jack of the channel being tested.
  - Be sure the signal output cable is connected to the correct output jack.
  - Close the channel being tested.
  - Verify that the insertion loss values at the various frequencies are within the limits stated in Table 4-2.

**Table 4-2**  
Insertion loss values

Frequency	Insertion loss
10MHz	<0.3dB
100MHz	<0.6dB
500MHz	<1dB
1GHz	<1.3dB
2GHz	<3dB

**Table 4-1**  
Recommended verification equipment

Description	Manufacturer and Model	Specifications	Test
Network Analyzer	Hewlett-Packard 8714ET	10MHz-2GHz	Insertion loss
Electrometer	Keithley 6517A	100MΩ, ±0.151% 1GΩ, ±0.226%	Isolation

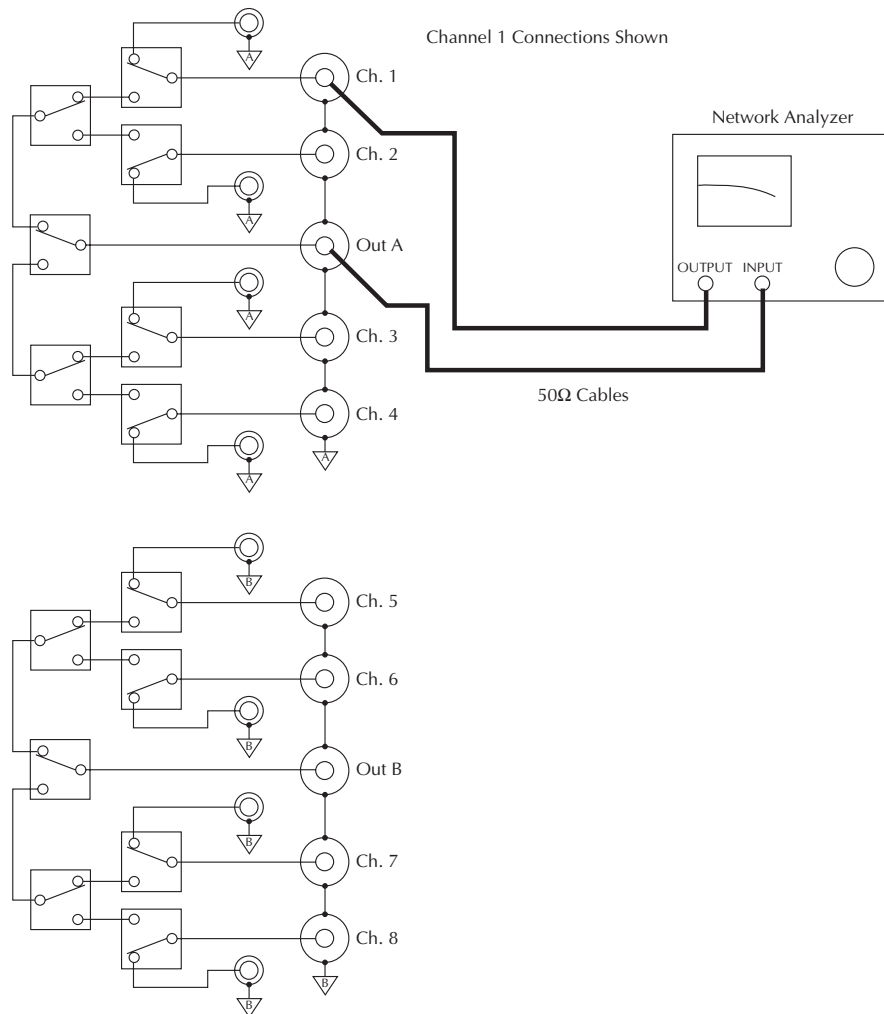

**Figure 4-1**  
Connections for insertion loss tests

#### 4.3.4 Isolation tests

These tests check the leakage resistance (isolation) between various Model 7016A terminals using the ohms function of a Model 6517A Electrometer.

#### CAUTION

**The following tests use the Model 6517A voltage source to measure resistance. Do not apply more than 30V to the Model 7016A to avoid card damage.**

#### Channel isolation tests

Perform the following steps to check channel isolation:

1. Connect the Model 6517A Electrometer to the center conductors of channels 1 and 2, as shown in Figure 4-2.
2. With the power off, install the Model 7016A card in the mainframe.
3. Turn on the mainframe and the Model 6517A power, and allow the electrometer to warm up for at least one hour before making measurements. Make sure the voltage source is turned off.
4. Select the Model 6517A ohms function, choose the 200MΩ range, and make certain zero check is disabled.
5. Close channel 1 on the Model 7016A.

6. Program the Model 6517A voltage source for 30V, and make sure the internal voltage source connection mode is selected.
7. Turn on the Model 6517A voltage source, and allow the reading to settle.
8. Verify that the Model 6517A resistance reading is  $>100M\Omega$ .
9. Turn off the voltage source, and open channel 1.
10. Repeat the procedure for channels 2 through 4, measuring the resistance between the center conductor of each channel and the center conductors of all other channels of multiplexer A. For each test:
  - Connect the electrometer to the center conductors of the two channels being tested.
  - Close only one of the channels being tested.
11. Repeat the entire procedure to test channel isolation between all multiplexer B channels (channels 5-8).

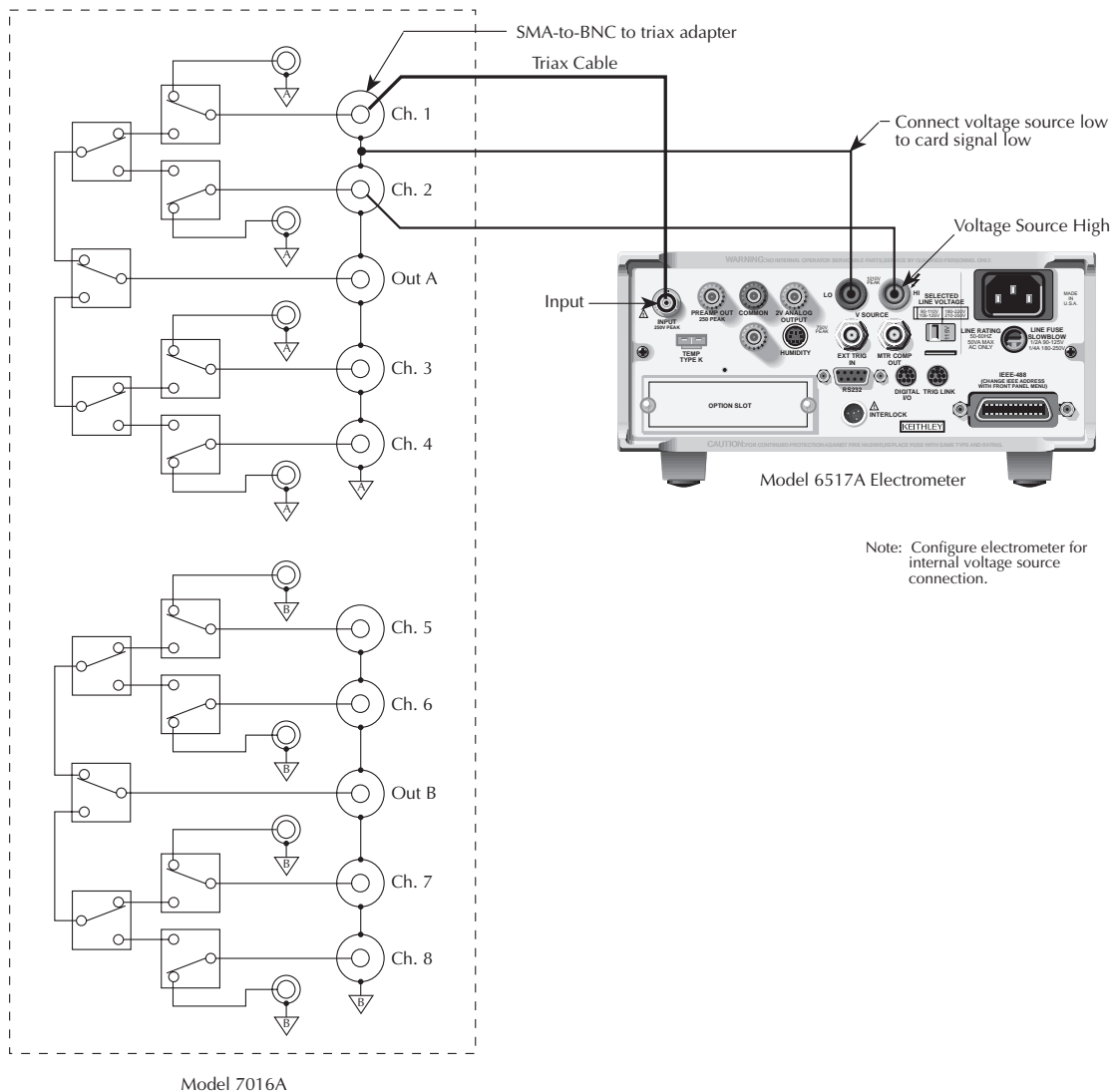
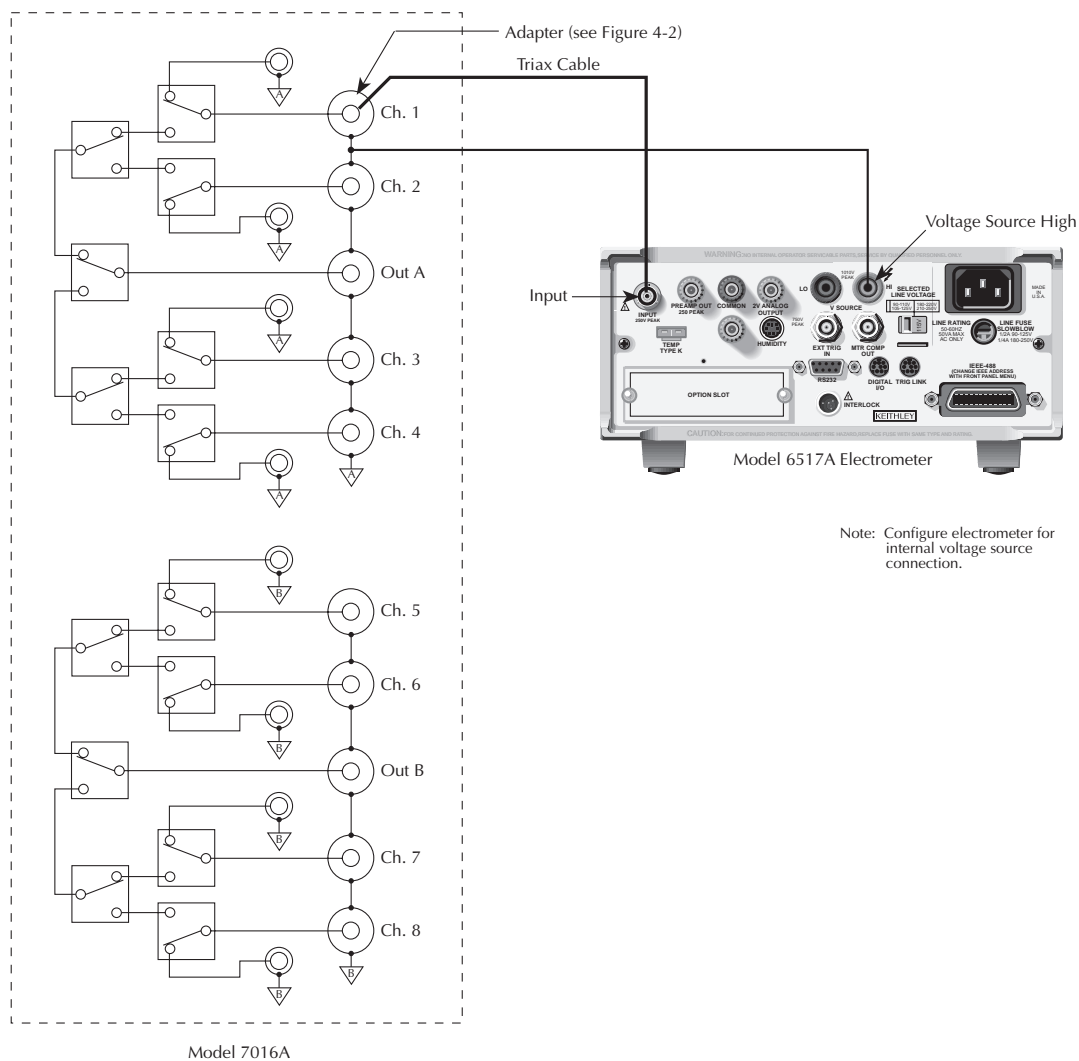

**Figure 4-2**  
Connections for channel isolation tests

### Center-to-shield isolation

Perform the following steps to check center-to-shield isolation:

1. Connect the Model 6517A Electrometer to the center conductor and shield of channel 1, as shown in Figure 4-3.
2. With the power off, install the Model 7016A card in the mainframe.
3. Turn on the mainframe and the Model 6517A power, and allow the electrometer to warm up for at least one hour before making measurements. Make sure the voltage source is turned off.
4. Select the Model 6517A ohms function, choose the 2GΩ range, and make certain zero check is disabled.
5. Close channel 1 on the Model 7016A.
6. Program the Model 6517A voltage source for 30V, and make sure the internal voltage source connection mode is selected.
7. Turn on the Model 6517A voltage source, and allow the reading to settle.
8. Verify that the Model 6517A resistance reading is >1GΩ.
9. Turn off the voltage source, and open channel 1.
10. Repeat the procedure for channels 2 through 8, measuring the resistance between the center conductor and shield of each channel. For each test:
  - Connect the electrometer to the center conductor and shield of the channel being tested.
  - Close only the channel being tested.

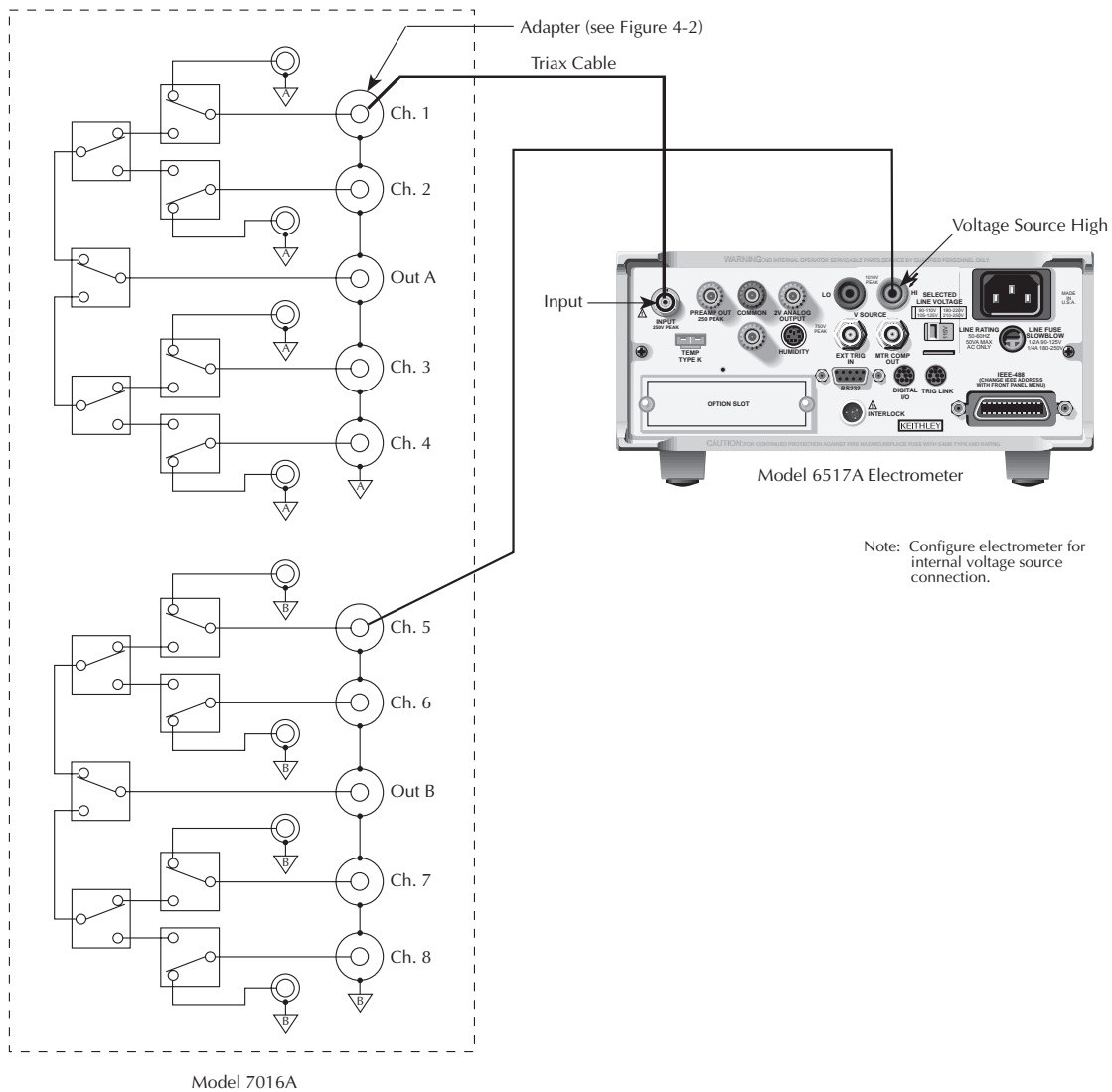

**Figure 4-3**  
Connections for center-to-shield isolation tests

### Multiplexer-to-multiplexer isolation

Perform the following steps to check multiplexer-to-multiplexer isolation:

1. Connect the Model 6517A Electrometer to the center conductors of channels 1 and 5, as shown in Figure 4-4.
2. With the power off, install the Model 7016A card in the mainframe.
3. Turn on the mainframe and the Model 6517A power, and allow the electrometer to warm up for at least one hour before making measurements. Make sure the voltage source is turned off.
4. Select the Model 6517A ohms function, choose the 2GΩ range, and make certain zero check is disabled.
5. Close channels 1 and 5 on the Model 7016A.
6. Program the Model 6517A voltage source for 30V, and make sure the internal voltage source connection mode is selected.
7. Turn on the Model 6517A voltage source, and allow the reading to settle.
8. Verify that the Model 6517A resistance reading is >1GΩ.
9. Turn off the voltage source, and open channels 1 and 5.



**Figure 4-4**  
Connections for multiplexer-to-multiplexer isolation tests



### 4.3.5 Special handling of static-sensitive devices

CMOS and other high-impedance devices are subject to possible static discharge damage because of the high-impedance levels involved. When handling such devices, observe the precautions listed below.

#### NOTE

To prevent damage, assume that all parts are static-sensitive.

1. Such devices should be transported and handled only in containers specially designed to prevent or dissipate static build-up. Typically, these devices will be received in anti-static containers made of plastic or foam. Keep these parts in their original containers until ready for installation or use.
2. Remove the devices from their protective containers only at a properly grounded workstation. Also, ground yourself with an appropriate wrist strap while working with these devices.
3. Handle the devices only by the body; do not touch the pins or terminals.

4. Any printed circuit board into which the device is to be inserted must first be grounded to the bench or table.
5. Use only anti-static type de-soldering tools and grounded-tip soldering irons.

## 4.4 Principles of operation

The following paragraphs discuss the basic Model 7016A operating principles that can be used as an aid in troubleshooting the card. The schematic diagram of the card is located at the end of Section 5.

### 4.4.1 Block diagram

Figure 4-5 shows a simplified block diagram of the Model 7016A. Key sections include the relay data control circuits, the relay driver IC, the relays, and the card configuration memory. These various elements are discussed in the following paragraphs.

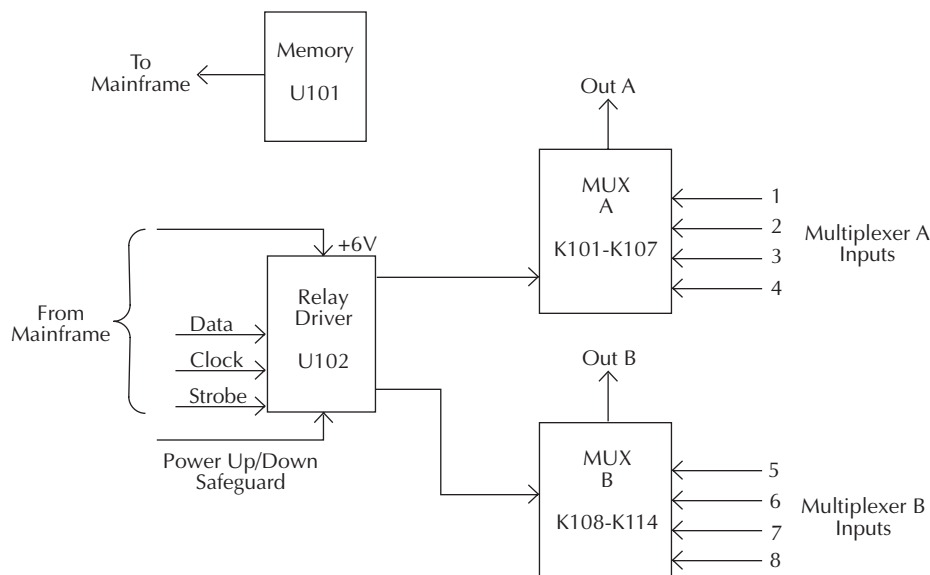

**Figure 4-5**  
Block diagram

## 4.4.2 Relay control

Card relays are controlled by serial data transmitted from the host switching mainframe via the DATA line. Each control byte is shifted in serial fashion into latches located in the card relay driver IC (U102). The serial data is clocked in by the CLK (clock) line.

Once the relay control byte has been shifted into the card, the STR line is set high to latch the relay information into the Q outputs of the relay drivers, and the appropriate relays are energized (assuming the driver outputs are enabled, as discussed below). Note that a relay driver output goes low to energize the corresponding relay.

The output enable (OE) line of U102 is controlled by the power-up/power-down safeguard circuit located in the mainframe. This circuit assures that no card relays are inadvertently energized when the mainframe power is turned on or off.

## 4.4.3 Switching circuits

Signal switching is performed by relays K101 through K114. K104-K104 switch channels 1 through 4, while K108-K111 switch channels 5 through 8. K105-K107 provide additional switching to assure proper isolation for multiplexer 1, while K112-K114 provide a similar function for multiplexer 2.

## 4.4.4 Card configuration memory

Card configuration information is stored in U101. This information is serially read by the mainframe during power-up and allows the unit to determine the card model number and card relay configuration information.

## 4.5 Troubleshooting

### 4.5.1 Troubleshooting equipment

Table 4-3 summarizes recommended equipment for troubleshooting the Model 7016A.

**Table 4-3**  
*Recommended troubleshooting equipment*

Description	Manufacturer and Model	Application
Multimeter	Keithley	DCV checks
Oscilloscope	TEK 2243	View logic waveforms

### 4.5.2 Troubleshooting procedure

Table 4-4 summarizes multiplexer card troubleshooting steps. Refer to the schematic diagram and component layout drawing at the end of Section 5 for component locations.

#### CAUTION

Use care when removing relays from the PC board to avoid pulling traces away from the circuit board. Before attempting to remove a relay, use an appropriate de-soldering tool to clear each mounting hole completely free of solder. Each relay pin must be free to move in its mounting hole before removal. Also, make certain that no burrs are present on the ends of the relay pins.

**Table 4-4**  
*Troubleshooting procedure*

Step	Item/component	Required condition	Comments
1	Digital ground P2001, pins 15 and 16		All voltages referenced to digital ground.
2	P2001, pin 1	+6VDC	Card 6V relay supply voltage.
3	P2001, pin 14	+5VDC	Card 5V logic supply voltage.
4	U102, pin 2	CLK pulses	During relay update sequence only.
5	U102, pin 3	DATA pulses	During relay update sequence only.
6	U102, pin 7	STR pulse	End of relay update sequence.
7	U102, pins 11-18	Low with relay energized, high with relay de-energized.	Relay driver outputs.

# 5

## Replaceable Parts

---

### 5.1 Introduction

This section contains replacement parts information, schematic diagrams, and component layout drawings for the Model 7016A.

### 5.2 Parts list

The parts list for the multiplexer card is included in tables integrated with the schematic diagram and component layout drawing. Parts are listed alphabetically in order of circuit designation.

### 5.3 Ordering information

To place an order, or to obtain information concerning replacement parts, contact your Keithley representative or the factory (see the inside front cover for addresses). When ordering parts, be sure to include the following information:

- Card model number (7016A)
- Card serial number
- Part description
- Circuit description, if applicable
- Keithley part number

### 5.4 Factory service

If the card is to be returned to Keithley Instruments for repair, perform the following:

- Call the Repair Department at 1-800-552-1115 for a Return Material Authorization (RMA) number.
- Complete the service form at the back of this manual and include it with the card.
- Carefully pack the card in the original packing carton.
- Write ATTENTION REPAIR DEPT and the RMA number on the shipping label.

#### NOTE

It is not necessary to return the switching mainframe with the card.

### 5.5 Component layout and schematic diagram

A component layout drawing and schematic diagram are included on the following pages integrated with the parts list.

**Table 5-1**  
*Model 7016A parts list*

<b>Circuit Desig.</b>	<b>Description</b>	<b>Keithley Part Number</b>
C101, 102	CAP, .1UF, 20%, 50V, CERAMIC	C-365-.1
C105, C106	CAP, 10UF, -20+100%, 25V, ALUM ELEC	C-314-10
CR101-106	DIODE, SILICON, 1N4148 (D0-35)	RF-28
J1001-1005, 1010-1014	CONNECTOR, SMA FEMALE	CS-839
J1006-1009, 1015-1018	CONN, SMB, MALE	CS-580
K101-114	RELAY, HI-FREQ	RL-238
P2001	CONNECTOR, 32-PIN, 2-ROWS	CS-775-1
U101	PROGRAM	7016-800**
U102	IC, 8-BIT SERIAL-IN LATCH DRIVER, 5841A	IC-536

\*\* Order firmware revision of present ROM.

7016A-100

LTR.	ECA NO.	REVISION	ENG.	DATE
A	23122	RELEASED	MS	4/28/99
A1	25918	CHANGED U101 TO TC17-100	ELS	6/19/01

ADD TC17-100 BOARD  
ORIENT ARROW TOWARD  
PIN 1 OF DEVICE

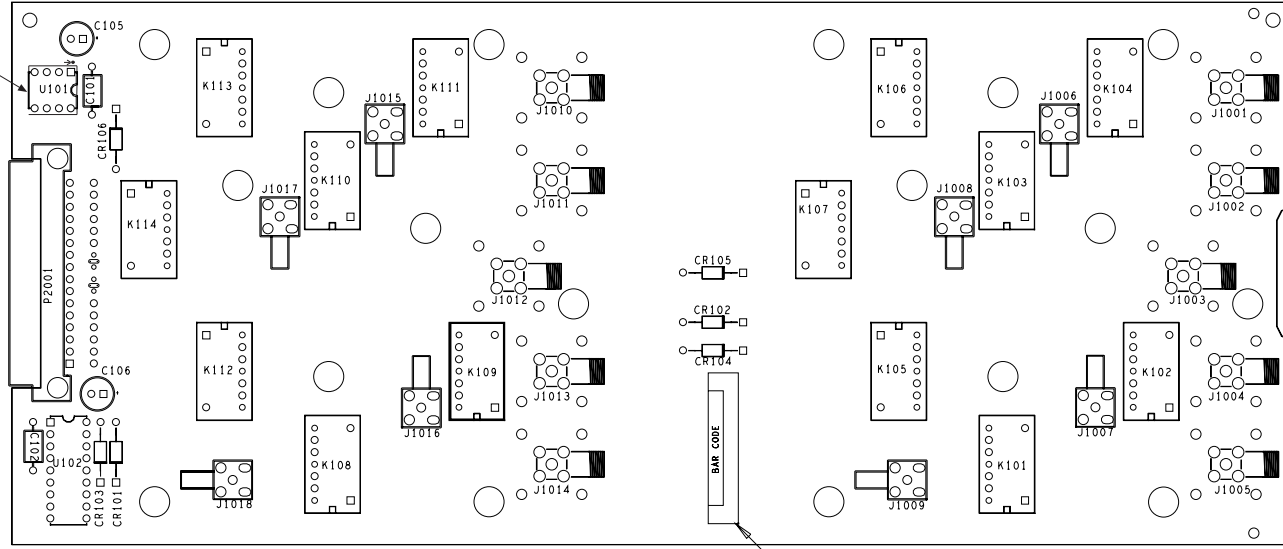

ADD MC285 (SOLDER SIDE -01)

NOTE: FOR MORE COMPONENT INFORMATION  
REFER TO THE PRODUCT STRUCTURE.

MODEL	NEXT ASSEMBLY	QTY.
USED ON		

 KEITHLEY INSTRUMENTS INC. CLEVELAND, OHIO 44139	DIM ARE IN IN. UNLESS OTHERWISE NOTED	DATE 4/28/99	SCALE 1:1	TITLE
	DIM. TOL. UNLESS OTHERWISE SPECIFIED	DRN MS	APPR. LK	COMPONENT LAYOUT
	XX = .01 XXX = .005	ANG. = .1 FRAC. = 1/64	DO NOT SCALE THIS DRAWING	B

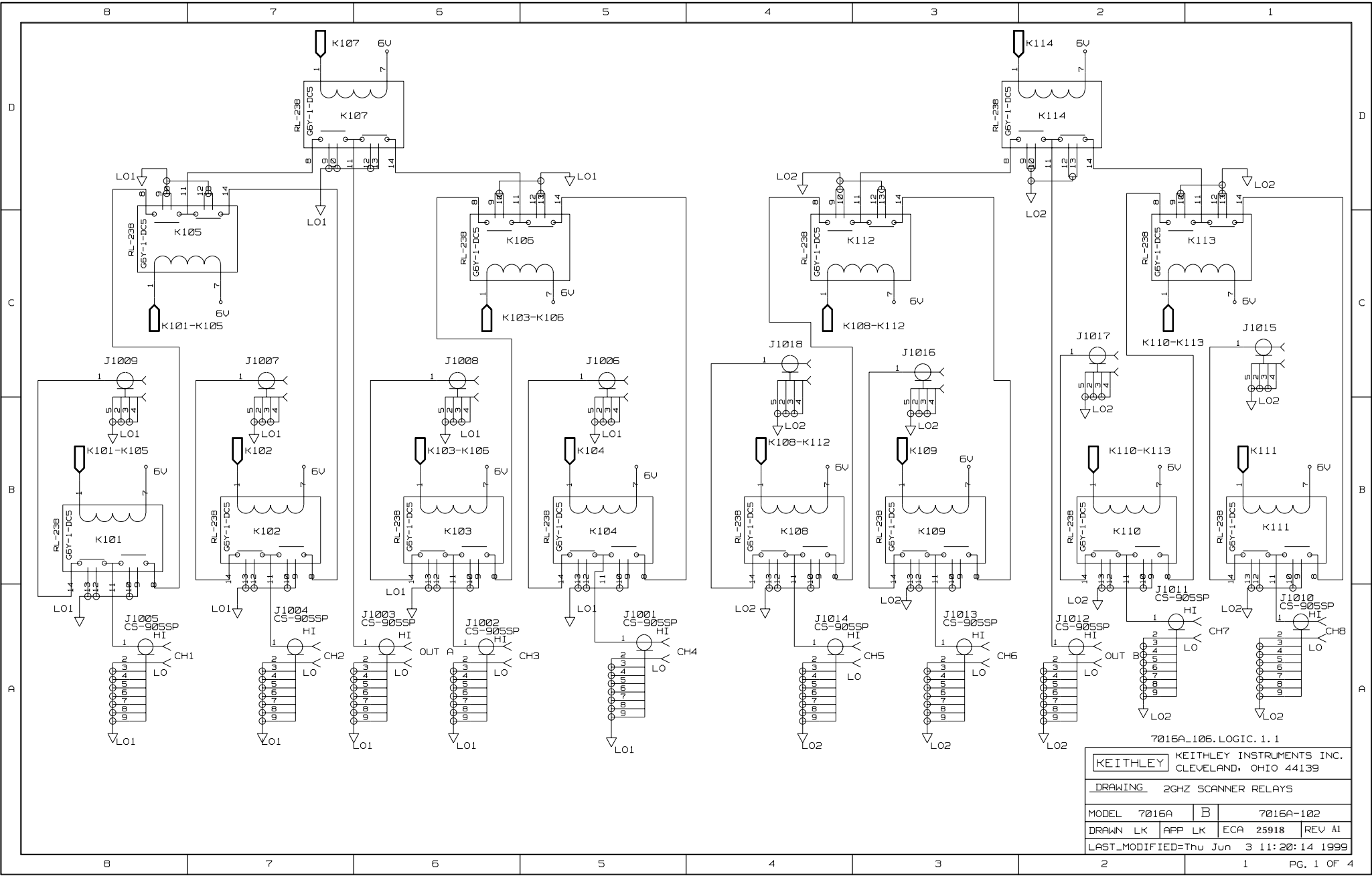

7016A-106, LOGIC, 1.1

KEITHLEY		KEITHLEY INSTRUMENTS INC. CLEVELAND, OHIO 44139	
DRAWING 2GHZ SCANNER RELAYS			
MODEL 7016A	B	7016A-102	
DRAWN LK	APP LK	ECA 25918	REV A1
LAST_MODIFIED=Thu Jun 3 11:20:14 1999			

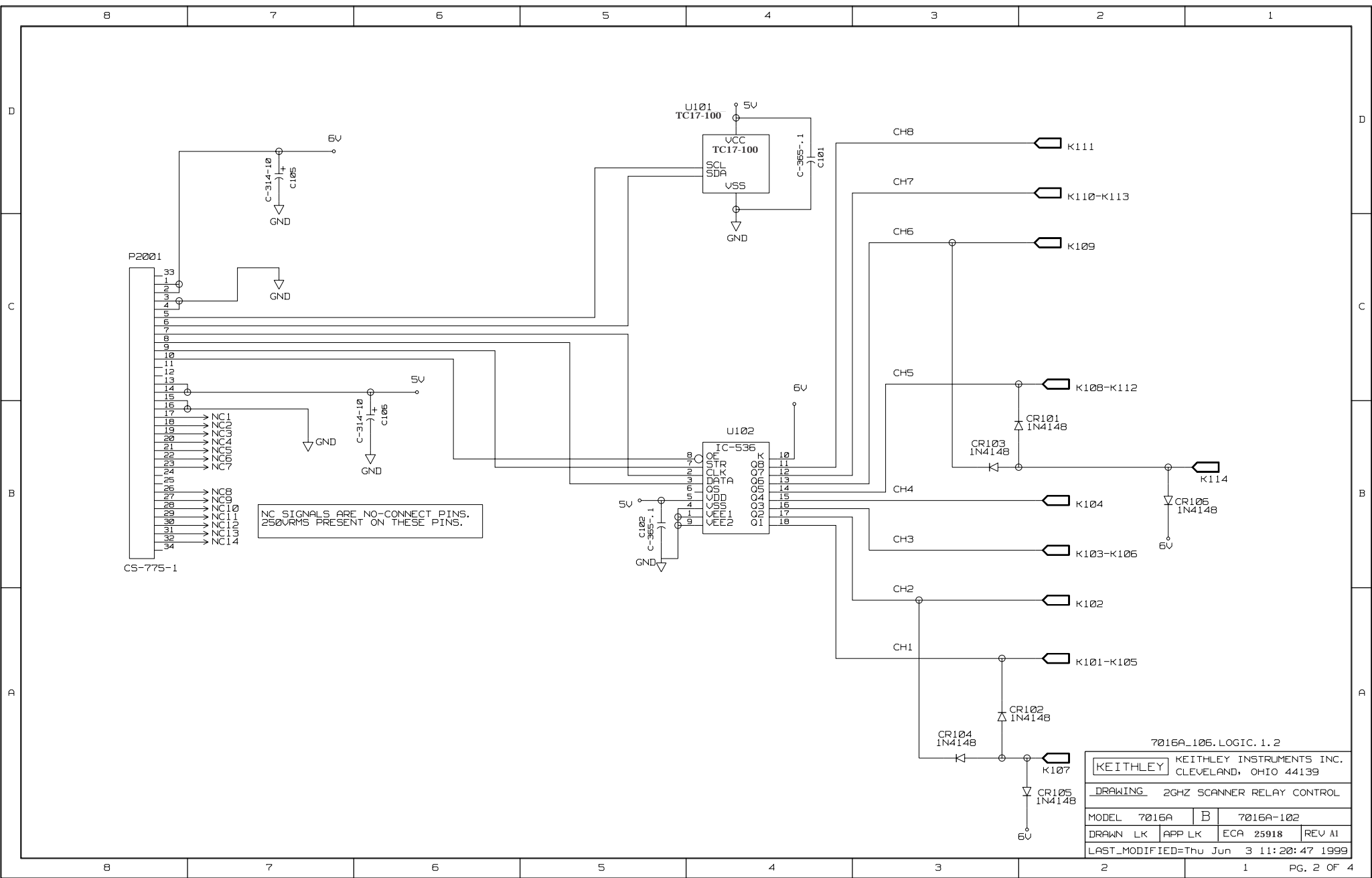

NC SIGNALS ARE NO-CONNECT PINS.  
250V RMS PRESENT ON THESE PINS.

7016A-106. LOGIC. 1. 2

KEITHLEY		KEITHLEY INSTRUMENTS INC. CLEVELAND, OHIO 44139	
DRAWING 2GHZ SCANNER RELAY CONTROL			
MODEL 7016A	B	7016A-102	
DRAWN LK	APP LK	ECA 25918	REV A1
LAST_MODIFIED=Thu Jun 3 11:20:47 1999			

8 7 6 5 4 3 2 1

D

C

B

A

8 7 6 5 4 3 2 1

\*\*\* Signal Cross-Reference \*\*\*  
--- for the entire design ---

5V 2B5 2C6 2D4  
6V 1B1 1B2 1B3 1B4 1B5 1B6 1B7 1B8 1C1  
1C3 1C5 1C7 1D2 1D6 2A3 2B2 2C4 2D7  
K101-K105 1B6 1C8 2A2  
K102 1B7 2A2  
K103-K106 1B6 1C6 2B2  
K104 1B5 2B2  
K107 1D7 2A2  
K108-K112 1B4 1C4 2C2  
K109 1B3 2C2  
K110-K113 1B2 1C2 2D2  
K111 1B1 2D2  
K114 1D3 2B2  
L01 1A5 1A5 1A6 1A6 1A7 1A7 1A7 1A8 1A8  
1B5 1B6 1B7 1B8 1C7 1D5 1D6  
L02 1A1 1A1 1A2 1A2 1A2 1A3 1A3 1A4 1A4  
1B1 1B2 1B3 1B4 1C2 1D1 1D4  
NC1 2B7  
NC2 2B7  
NC3 2B7  
NC4 2B7  
NC5 2B7  
NC6 2B7  
NC7 2B7  
NC8 2B7  
NC9 2B7  
NC10 2B7  
NC11 2B7  
NC12 2B7  
NC13 2B7  
NC14 2B7

CREFOUT.LOGIC.1.3

KEITHLEY		KEITHLEY INSTRUMENTS INC. CLEVELAND, OHIO 44139	
DRAWING 2GHZ SCANNER RELAYS CROSS REFERENCE			
MODEL 7016A	B	7016A-102	
DRAWN LK	APP LK	ECA 25918	REV A1
LAST_MODIFIED=Thu Jun 3 11:21:18 1999			



8

7

6

5

4

3

2

1

\*\*\* Unit Cross-Reference \*\*\*  
 --- for the entire design ---

C101 CAPACITOR 2D4  
 C102 CAPACITOR 2B5  
 C105 ELCAP 2D7  
 C106 ELCAP 2B6  
 CR101 RF-28 2B2  
 CR102 RF-28 2A3  
 CR103 RF-28 2B3  
 CR104 RF-28 2A3  
 CR105 RF-28 2A2  
 CR106 RF-28 2B1  
 J1001 CS-905SP 1A5  
 J1002 CS-905SP 1A6  
 J1003 CS-905SP 1A6  
 J1004 CS-905SP 1A7  
 J1005 CS-905SP 1A8  
 J1006 CS-580 1C5  
 J1007 CS-580 1C7  
 J1008 CS-580 1C6  
 J1009 CS-580 1C8  
 J1010 CS-905SP 1A1  
 J1011 CS-905SP 1A2  
 J1012 CS-905SP 1A2  
 J1013 CS-905SP 1A3  
 J1014 CS-905SP 1A4  
 J1015 CS-580 1C1  
 J1016 CS-580 1C3  
 J1017 CS-580 1C2  
 J1018 CS-580 1C4  
 K101 RL-238 1B8  
 K102 RL-238 1B7  
 K103 RL-238 1B6  
 K104 RL-238 1B5  
 K105 RL-238 1C8  
 K106 RL-238 1C6  
 K107 RL-238 1D7  
 K108 RL-238 1B4  
 K109 RL-238 1B3  
 K110 RL-238 1B2  
 K111 RL-238 1B1  
 K112 RL-238 1C4  
 K113 RL-238 1C2  
 K114 RL-238 1D2  
 P2001 CS-775-1 2C8  
 U101 TC17-100 2D5  
 U102 IC-536 2B4

CREFOUT.LOGIC.1.4

KEITHLEY

KEITHLEY INSTRUMENTS INC.  
CLEVELAND, OHIO 44139DRAWING 2GHZ SCANNER RELAYS  
CROSS REFERENCE

MODEL 7016A B 7016A-102

DRAWN LK APP LK ECA 25918 REV A1

LAST\_MODIFIED=Thu Jun 3 12:51:26 1999

8

7

6

5

4

3

2

1

PG. 4 OF 4

## A

Applications 3-3

## B

Block diagram 4-7

## C

Caution 1-1  
Connecting cables 1-2  
Connections and installation 2-1  
Connections 2-1  
Card configuration 2-1  
Card installation and removal 2-4  
Card installation 2-5  
Card removal 2-5  
Closing and opening channels 3-1, 3-2  
Card characteristics 3-2  
Capacitance 3-2  
Crosstalk 3-2  
Cable characteristics 3-3  
Cable attenuation 3-3  
Cable termination 3-3  
Cable connectors 3-3  
Channel isolation tests 4-3  
Characteristic impedance 3-3  
Center-to-shield isolation 4-5  
Card configuration memory 4-8  
Component layout and schematic diagram 5-1

## D

Distributed capacitance 3-3

## E

Environmental conditions 4-2

## F

Features 1-1  
Front panel control 3-1  
Filter testing 3-6  
Factory service 5-1

## G

General Information 1-1

## H

Handling precautions 1-2, 2-1  
Handling and cleaning precautions 4-1  
Handling precautions 4-1

## I

Inspection for damage 1-2  
Instruction manual 1-2  
Input/output connecting cables 2-3  
Input termination 2-4  
IEEE-488 bus control 3-2  
Insertion loss 3-2  
Impedance testing 3-6  
Insertion loss tests 4-2  
Isolation tests 4-3

## M

Manual addenda 1-1  
Multiplexer expansion 3-3  
Multiplexer-to-multiplexer isolation 4-6

## O

Operation 3-1  
Ordering information 5-1

## P

Path isolation resistance 3-3  
Performance verification 4-1  
Principles of operation 4-7  
Parts list 5-1

## R

Repacking for shipment 1-2  
Recommended accessories 1-2  
Recommended verification equipment 4-2  
Relay control 4-8  
Replaceable parts 5-1

## S

Safety symbols and terms 1-1  
Specifications 1-1  
Shipment contents 1-2  
Simplified schematic 2-1  
Signal limitation 3-1  
Scanning channels 3-2  
Switching considerations 3-2  
Service information 4-1  
Soldering considerations 4-1  
Special handling of static-sensitive devices 4-7  
Switching circuits 4-8

## T

Terminating resistors 1-2  
Typical connecting scheme 2-3  
Troubleshooting equipment 4-8  
Troubleshooting procedure 4-8

## U

Unpacking and inspection 1-2

## V

VSWR 3-3

## W

Warranty information 1-1  
Warning 1-1



# Service Form

Model No. \_\_\_\_\_ Serial No. \_\_\_\_\_ Date \_\_\_\_\_

Name and Telephone No. \_\_\_\_\_

Company \_\_\_\_\_

List all control settings, describe problem and check boxes that apply to problem. \_\_\_\_\_

- |  |  |  |
|--|--|--|
| <input type="checkbox"/> Intermittent            | <input type="checkbox"/> Analog output follows display   | <input type="checkbox"/> Particular range or function bad; specify |
| <input type="checkbox"/> IEEE failure            | <input type="checkbox"/> Obvious problem on power-up     | <input type="checkbox"/> Batteries and fuses are OK                |
| <input type="checkbox"/> Front panel operational | <input type="checkbox"/> All ranges or functions are bad | <input type="checkbox"/> Checked all cables                        |

Display or output (check one)

- |                                   |  |
|-----------------------------------|--|
| <input type="checkbox"/> Drifts   | <input type="checkbox"/> Unable to zero              |
| <input type="checkbox"/> Unstable | <input type="checkbox"/> Will not read applied input |
| <input type="checkbox"/> Overload |  |

- |   |  |
|---|--|
| <input type="checkbox"/> Calibration only | <input type="checkbox"/> Certificate of calibration required |
| <input type="checkbox"/> Data required    |  |

(attach any additional sheets as necessary)

Show a block diagram of your measurement system including all instruments connected (whether power is turned on or not). Also, describe signal source.

Where is the measurement being performed? (factory, controlled laboratory, out-of-doors, etc.)

What power line voltage is used? \_\_\_\_\_ Ambient temperature? \_\_\_\_\_ °F

Relative humidity? \_\_\_\_\_ Other? \_\_\_\_\_

Any additional information. (If special modifications have been made by the user, please describe.)

Be sure to include your name and phone number on this service form.



**Keithley Instruments, Inc.**

28775 Aurora Road  
Cleveland, Ohio 44139

Printed in the U.S.A.