

Model 7058 Low Current Scanner Plug-In Card

Instruction Manual

Contains Operating and Servicing Information

KEITHLEY

WARRANTY

Keithley Instruments, Inc. warrants this product to be free from defects in material and workmanship for a period of 1 year from date of shipment.

Keithley Instruments, Inc. warrants the following items for 90 days from the date of shipment: probes, cables, rechargeable batteries, diskettes, and documentation.

During the warranty period, we will, at our option, either repair or replace any product that proves to be defective.

To exercise this warranty, write or call your local Keithley representative, or contact Keithley headquarters in Cleveland, Ohio. You will be given prompt assistance and return instructions. Send the product, transportation prepaid, to the indicated service facility. Repairs will be made and the product returned, transportation prepaid. Repaired or replaced products are warranted for the balance of the original warranty period, or at least 90 days.

LIMITATION OF WARRANTY

This warranty does not apply to defects resulting from product modification without Keithley's express written consent, or misuse of any product or part. This warranty also does not apply to fuses, software, non-rechargeable batteries, damage from battery leakage, or problems arising from normal wear or failure to follow instructions.

THIS WARRANTY IS IN LIEU OF ALL OTHER WARRANTIES, EXPRESSED OR IMPLIED, INCLUDING ANY IMPLIED WARRANTY OF MERCHANTABILITY OR FITNESS FOR A PARTICULAR USE. THE REMEDIES PROVIDED HEREIN ARE BUYER'S SOLE AND EXCLUSIVE REMEDIES.

NEITHER KEITHLEY INSTRUMENTS, INC. NOR ANY OF ITS EMPLOYEES SHALL BE LIABLE FOR ANY DIRECT, INDIRECT, SPECIAL, INCIDENTAL OR CONSEQUENTIAL DAMAGES ARISING OUT OF THE USE OF ITS INSTRUMENTS AND SOFTWARE EVEN IF KEITHLEY INSTRUMENTS, INC. HAS BEEN ADVISED IN ADVANCE OF THE POSSIBILITY OF SUCH DAMAGES. SUCH EXCLUDED DAMAGES SHALL INCLUDE, BUT ARE NOT LIMITED TO: COSTS OF REMOVAL AND INSTALLATION, LOSSES SUSTAINED AS THE RESULT OF INJURY TO ANY PERSON, OR DAMAGE TO PROPERTY.



Keithley Instruments, Inc. • 28775 Aurora Road • Cleveland, OH 44139 • 216-248-0400 • Fax: 216-248-6168 • <http://www.keithley.com>

CHINA:	Keithley Instruments China • Yuan Chen Xia Building, Room 705 • No. 12 Yuanjin Road, Dewai, Maolan • Beijing, China 100029 • 8610-2022896 • Fax: 8610-2022892
FRANCE:	Keithley Instruments SARL • DP 60 • 3 allée des Caray • 91122 Palaiseau Cedex • 31-6-0117155 • Fax: 31-6-0117726
GERMANY:	Keithley Instruments GmbH • Landsberger Straße 65 • 82110 Garming • 49-89-349307-0 • Fax: 49-89-34920759
GREAT BRITAIN:	Keithley Instruments, Ltd. • The Minster • 58 Portman Road • Reading, Berkshire RG30 1EA • 44-01754 575666 • Fax: 44-01754-596469
ITALY:	Keithley Instruments SRL • Viale S. Orsogrosso 38 • 20146 Milano • 39-2-48303008 • Fax: 39-2-48302274
JAPAN:	Keithley KK • Aibido Bldg. • 7-20-2 Nishitshinjuku • Shinjuku-ku, Tokyo 160 • 81-3-5389-1961 • Fax: 81-3-5389-2068
NETHERLANDS:	Keithley Instruments BV • Avelingen West 49 • 4202 MS Gorinchem • 31-(0)183-635333 • Fax: 31-(0)183-630821
SWITZERLAND:	Keithley Instruments SA • Kriessbachstrasse 4 • 8600 Dübendorf • 41-1-8219444 • Fax: 41-1-8203081
TAIWAN:	Keithley Instruments Taiwan • 1, Ming-Yu First Street • Hsinchu, Taiwan, R.O.C. • 886-35-778462 • Fax: 886-35-778455

Model 7058 Low Current Scanner Plug-In Card Instruction Manual

© 1991, Keithley Instruments, Inc.
Test Instrumentation Group
All rights reserved.
Cleveland, Ohio, U.S.A.
October 1991, Second Printing
Document Number: 7058-901-01 Rev. B

Safety Precautions

The following safety precautions should be observed before using this product and any associated instrumentation. Although some instruments and accessories would normally be used with non-hazardous voltages, there are situations where hazardous conditions may be present.

This product is intended for use by qualified personnel who recognize shock hazards and are familiar with the safety precautions required to avoid possible injury. Read the operating information carefully before using the product.

The types of product users are:

Responsible body is the individual or group responsible for the use and maintenance of equipment, for ensuring that the equipment is operated within its specifications and operating limits, and for ensuring that operators are adequately trained.

Operators use the product for its intended function. They must be trained in electrical safety procedures and proper use of the instrument. They must be protected from electric shock and contact with hazardous live circuits.

Maintenance personnel perform routine procedures on the product to keep it operating, for example, setting the line voltage or replacing consumable materials. Maintenance procedures are described in the manual. The procedures explicitly state if the operator may perform them. Otherwise, they should be performed only by service personnel.

Service personnel are trained to work on live circuits, and perform safe installations and repairs of products. Only properly trained service personnel may perform installation and service procedures.

Exercise extreme caution when a shock hazard is present. Lethal voltage may be present on cable connector jacks or test fixtures. The American National Standards Institute (ANSI) states that a shock hazard exists when voltage levels greater than 30V RMS, 42.4V peak, or 60VDC are present. **A good safety practice is to expect that hazardous voltage is present in any unknown circuit before measuring.**

Users of this product must be protected from electric shock at all times. The responsible body must ensure that users are prevented access and/or insulated from every connection point. In some cases, connections must be exposed to potential human contact. Product users in these circumstances must be trained to protect themselves from the risk of electric shock. If the circuit is capable of operating at or above 1000 volts, **no conductive part of the circuit may be exposed.**

As described in the International Electrotechnical Commission (IEC) Standard IEC 664, digital multimeter measuring circuits (e.g., Keithley Models 175A, 199, 2000, 2001, 2002, and 2010) are Installation Category II. All other instruments' signal terminals are Installation Category I and must not be connected to mains.

Do not connect switching cards directly to unlimited power circuits. They are intended to be used with impedance limited sources. **NEVER** connect switching cards directly to AC mains. When connecting sources to switching cards, install protective devices to limit fault current and voltage to the card.

Before operating an instrument, make sure the line cord is connected to a properly grounded power receptacle. Inspect the connecting cables, test leads, and jumpers for possible wear, cracks, or breaks before each use.

For maximum safety, do not touch the product, test cables, or any other instruments while power is applied to the circuit under test. **ALWAYS** remove power from the entire test system and discharge any capacitors before: connecting or disconnecting cables or jumpers, installing or

removing switching cards, or making internal changes, such as installing or removing jumpers. Do not touch any object that could provide a current path to the common side of the circuit under test or power line (earth) ground. Always make measurements with dry hands while standing on a dry, insulated surface capable of withstanding the voltage being measured.

The instrument and accessories must be used in accordance with its specifications and operating instructions or the safety of the equipment may be impaired.

Do not exceed the maximum signal levels of the instruments and accessories, as defined in the specifications and operating information, and as shown on the instrument or test fixture panels, or switching card.

When fuses are used in a product, replace with same type and rating for continued protection against fire hazard.

Chassis connections must only be used as shield connections for measuring circuits, NOT as safety earth ground connections.

If you are using a test fixture, keep the lid closed while power is applied to the device under test. Safe operation requires the use of a lid interlock.

If a  screw is present, connect it to safety earth ground using the wire recommended in the user documentation.

The  symbol on an instrument indicates that the user should refer to the operating instructions located in the manual.

The  symbol on an instrument shows that it can source or measure 1000 volts or more, including the combined effect of normal and common mode voltages. Use standard safety precautions to avoid personal contact with these voltages.

The **WARNING** heading in a manual explains dangers that might result in personal injury or death. Always read the associated information very carefully before performing the indicated procedure.

The **CAUTION** heading in a manual explains hazards that could damage the instrument. Such damage may invalidate the warranty.

Instrumentation and accessories shall not be connected to humans.

Before performing any maintenance, disconnect the line cord and all test cables.

To maintain protection from electric shock and fire, replacement components in mains circuits, including the power transformer, test leads, and input jacks, must be purchased from Keithley Instruments. Standard fuses, with applicable national safety approvals, may be used if the rating and type are the same. Other components that are not safety related may be purchased from other suppliers as long as they are equivalent to the original component. (Note that selected parts should be purchased only through Keithley Instruments to maintain accuracy and functionality of the product.) If you are unsure about the applicability of a replacement component, call a Keithley Instruments office for information.

To clean an instrument, use a damp cloth or mild, water based cleaner. Clean the exterior of the instrument only. Do not apply cleaner directly to the instrument or allow liquids to enter or spill on the instrument. Products that consist of a circuit board with no case or chassis (e.g., data acquisition board for installation into a computer) should never require cleaning if handled according to instructions. If the board becomes contaminated and operation is affected, the board should be returned to the factory for proper cleaning/servicing.

SPECIFICATIONS

7058 LOW CURRENT SCANNER CARD

CHANNELS PER CARD: 10.

CONTACT CONFIGURATION: Single pole, break-before-make for signal HI input. Signal LO is common for all 10 channels. When a channel is off, signal HI is connected to signal LO through an internal jumper.

CONNECTOR TYPE: Triaxial.

RELAY DRIVE CURRENT: 24mA per relay typical.

SIGNAL LEVEL: 28V, 100mA maximum (non-inductive load only).

CONTACT LIFE: >10⁶ closures at maximum signal levels.

CONTACT RESISTANCE: < 1Ω to rated life.

CONTACT POTENTIAL: < 250μV.

ACTUATION TIME: < 15ms, exclusive of mainframe.

CHANNEL ISOLATION: >10¹⁵Ω, <0.1pF with internal jumper removed.

INPUT ISOLATION: >10¹⁰Ω, <50pF.

OFFSET CURRENT: <10⁻¹²A (<10⁻¹³A typical).

COMMON MODE VOLTAGE: <100V peak.

GENERAL

OPERATING ENVIRONMENT: 0° to 50°C, up to 35°C at 70% RH.

STORAGE ENVIRONMENT: -25°C to 65°C.

DIMENSIONS, WEIGHT: 32mm high × 114mm wide × 272mm long (1¼" × 4½" × 10¾"). Net weight 0.54kg (19 oz.).

ACCESSORIES AVAILABLE:

Model 7024-3 Triaxial Cable, 0.9m (3 ft.)

Model 7024-5 Triaxial Cable, 1.5m (5 ft.)

Model 7024-10 Triaxial Cable, 3.0m (10 ft.)

Model 7023 Female Triaxial Connector

NOTE

Because of the high impedance of the board special care should be taken in both handling and using the board to prevent degradation of performance. Handle the board only by the edges when using it and keep the board free of body oils, dirt and contaminants. To clean the board use Freon® TMS or TE or equivalent and a clean cotton swab or soft brush. Care should be taken to ensure that the solvent is not contaminated before using it on the board. After the solvent has been applied blow dry the board with dry nitrogen gas.

TABLE OF CONTENTS

SECTION 1—GENERAL INFORMATION		
1.1	Introduction	1
1.2	Warranty Information	1
1.3	Manual Addenda	1
SECTION 2—OPERATION		
2.1	Introduction	3
2.2	Wiring and Installation	3
2.3	Operating Considerations	4
2.3.1	Limits on Switching Speed	4
2.4	Model 7058 Modification	5
SECTION 3—SERVICING INFORMATION		
3.1	Introduction	7
3.2	Handling Instructions	7
3.3	Test Equipment	7
3.4	Performance Verification	8
SECTION 4—REPLACEABLE PARTS		
4.1	Introduction	13
4.2	Replaceable Parts	13
4.3	Ordering Information	13
4.4	Factory Service	13
4.5	Component Layout and Schematic Diagram	13

LIST OF FIGURES

1	Typical Multi-Scanner Connection	3
2	Typical Switching Circuit For Model 7058	4
3	Jumper Modification	5
4	Test Set Up for Offset Current Test	9
5	Test Set Up for Signal Path Resistance Test	9
6	Test Set Up for Shunt Impedance Test	9
7	Test Set Up for Relay Timing Test	10
8	Channel Isolation Test	11
9	Model 7058 Component Location Drawing	14
10	Model 708 Schematic Diagram	16

LIST OF TABLES

1	Recommended Test Equipment	12
2	Model 7058 Replaceable Parts List	13

SECTION 1

GENERAL INFORMATION

1.1 INTRODUCTION

The Model 7058 is a low-current scanner plug-in card which is field-installable in the Model 705 scanner mainframe. The Model 7058 will switch up to 10 channels. For optimum low level current switching, the Model 7058 is designed to introduce a minimum of offset current error ($< 1.0\text{pA}$), while guarding ensures that high isolation ($10^{15}\Omega$) is maintained between input signals. The break-before-make, single-pole switching of the Model 705 scanner mainframe is designed to maintain current paths for signals not connected to the output to provide high input resistance for making voltage measurements. AC or DC signals up to 100mA or 28V may be switched. Triaxial input and output connections to the scanner plug-in card are easily made through the rear panel of the scanner mainframe using optional triaxial mating cables.

1.2 WARRANTY INFORMATION

Warranty information is stated on the inside front cover of the manual. If there is a need for service, contact the Keithley representative or authorized repair facility in your area. Check the back cover of this manual for addresses. The service form supplied at the back of the manual should be used to provide the repair facility with adequate information concerning any difficulty.

1.3 MANUAL ADDENDA

Any improvements or changes to this manual will be explained on an addendum included with this manual.

SECTION 2 OPERATION

2.1 INTRODUCTION

This section provides information needed to use the Model 7058 with the Model 705 scanner mainframe.

2.2 WIRING AND INSTALLATION

1. Wiring Configuration— The Model 7058 incorporates a single pole, switching configuration. The Model 7058 will switch any one of 10 signals to one output, or switch one signal to any one of 10 outputs.
 - A. All signal inputs and outputs are made by means of the triaxial connectors on the card. The location for each channel input and the output is indicated on the shield covers.
 - B. The input connectors for channels 1 through 4 are located at the rear of the card. The two OUTPUT connectors permit multiple Model 7058's to be connected together. For instance a 30 channel scanner system may be connected as shown in Figure 1.
 - C. The signal HI path is switched and signal LO is common for all 10 channels. An additional relay serves to isolate all circuitry on the card from the output connectors when no channel is selected.
 - D. The contact configuration is designed for applications where current sources are to be scanned. That is, each source is short-circuited when it is not being selected. This short circuit is made through a removeable jumper located on the underside of the board (see Figure 2). For applications where such a short circuit is not desired, as in high impedance voltage measurements, the jumper may be removed completely or replaced with a $\frac{1}{4}$ watt composition resistor if desired.
 - E. Caps are provided for all connectors. All unused input connectors should be capped to prevent the insulators from being contaminated. Unused output connectors should be capped unless the additional capacitive coupling due to the cap between signal HI on the output connector and the outside shell is undesirable. This consideration only becomes important in the presence of very large or noisy common-mode voltages in the system.
 - F. The outside shell of the triaxial connector is common for all channels in the system and is not connected to the mainframe chassis ground. Care should be taken that ground loops are not formed due to multiple ground connections.

NOTE

The outside shell connection for the card must be made at either the sources or at the measuring instrument.

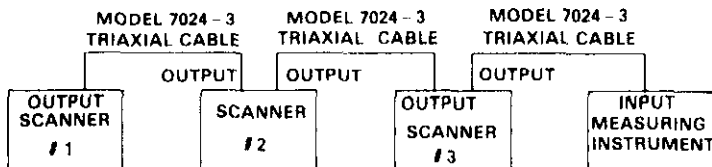

Figure 1. Typical Multi-Scanner Connection

2. Installation—Refer to the Model 705 Instruction Manual for scanner card installation instructions.

2.3 OPERATING CONSIDERATIONS

2.3.1 Limits on Switching Speed

1. Current Error in the Picoampere Region—Any time a channel is selected some degree of charge transfer can be expected due to the mechanical release or closure of the contacts. This charge transfer causes a current pulse whenever the channel is changed. The effect that this pulse will have on the signal will depend on the magnitude of the source to be measured. The amount of charge which is transferred when a channel is changed is generally in the picocoulomb range. When the scanner has been used to measure voltages, that is, if a voltage has been applied between signal HI and LO, then caution should be taken when measuring low currents in the scanner. In such a case the offset currents caused by the di-electric absorption will decay after a period of time. The rate of this decay is determined by ambient temperature and the magnitude and duration of the applied voltage.

NOTE

In the case of high voltages at fairly low temperatures, time constants in excess of one hour may be observed for this effect.

Extreme environmental conditions can also cause the offset current to go beyond 1pA. If the scanner has been exposed to very high humidity and/or temperature (for instance during shipping) the board should be allowed to stabilize at an environment within the specified limits for approximately 24 hours.

2. Signal LO Used as a Guard—All internal wiring of the scanner is designed in such a way that the signal LO connection is used as a common guard which surrounds all inputs. That is, all wiring for the signal HI is done such that no DC current paths exist between the signal HI terminals of any input channel and any terminal other than signal LO. The additional switching at the output of the card allows each card in a multiple scanner system to have an independent signal LO.
3. Noise Caused By Cable Flexing—Whenever low level signals (picoamps) are being measured all signal cables should be kept as still as possible by fastening them to a rigid surface. This will help to reduce noise caused by the flexing of the cables. System response will be influenced by the amount of cable capacitance in the system. This should be considered when the sources are connected to the scanner. Using a feedback type ammeter (or an electrometer in "FAST" mode) for currents below 10^{-5} A is recommended to increase measurement speed and decrease the effects of cable capacitance.

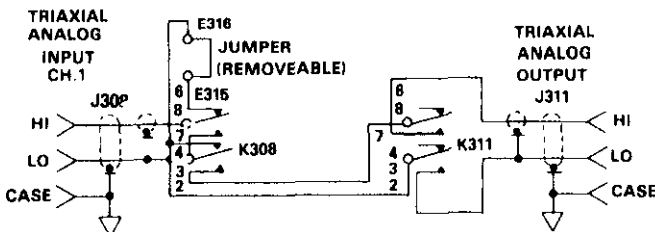

NOTE: WITH JUMPER INSTALLED, INPUT HI IS SHORTED TO INPUT LO WHEN CHANNEL IS NOT ACTIVATED.

Figure 2. Typical Switching Circuit For Model 7058

2.4 MODEL 7058 MODIFICATION

On the Model 7058 low current scanner card, Channel LO is connected to output HI. If isolation is required between Channel LO and Output HI, the Model 7058 can be modified to disconnect Channel LO from output HI when all the relays are off (relay K311 not energized). Relay K311 is an isolation relay that isolates all circuitry on the card from the output connectors when no channel is selected. The modification involves removing a jumper wire that is shown in Figure 3. After the jumper wire is removed, clean all the circuitry involved with Freon[®] TMS or TE or equivalent. Then blow dry the circuitry with dry nitrogen gas.

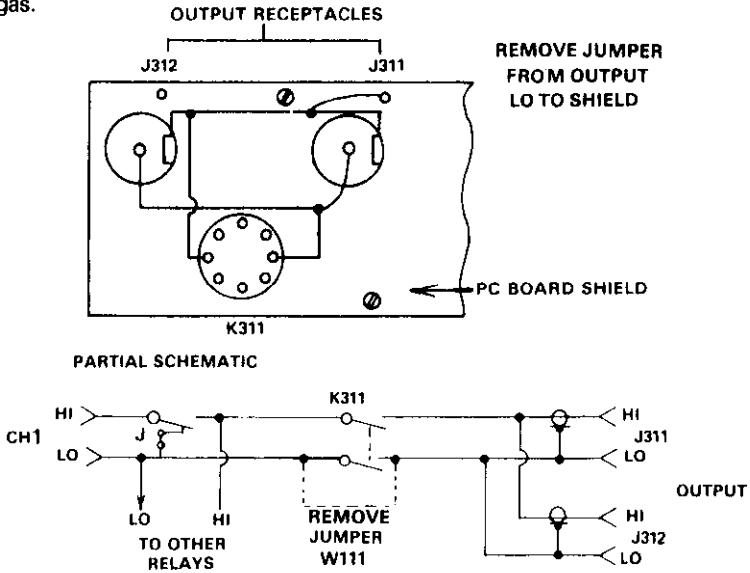

Figure 3. Jumper Modification

SECTION 3

SERVICING INFORMATION

3.1 INTRODUCTION

This section contains a performance verification procedure. Since there are no calibration adjustments, no recalibration is necessary. Recommended maintenance would include inspection of the scanner plug-in board and card-edge connector to ensure good electrical contact. In industrial environments annual cleaning using Freon[®] TMS or TE and dry nitrogen gas. The verification procedure should be performed upon receiving the Model 7058 or at the time maintenance is performed on the mainframe.

3.2 HANDLING INSTRUCTIONS

Because of the high impedance wiring techniques used on the Model 7058, special care should be taken in both handling and using the card to prevent degradation of performance. Some precautions which should be followed are:

1. Avoid touching any exposed teflon insulators, the coaxial cable under the card, or the inside of the cable connectors. This will help prevent contamination of these surfaces.
2. Whenever the card is not being used in the mainframe it should be placed on a clean surface or preferably in a plastic bag.
3. If the factory installed jumpers are to be removed, they should be cut out, not unsoldered to prevent the possibility of flux vapor from contaminating the insulators.
4. If it becomes necessary to solder the jumpers back on to the card, the soldering should be done carefully and the board cleaned with Freon[®] TMS or TE and blown dry with dry nitrogen gas.
5. If a large offset current develops on the card from exposure to high humidity; this offset can be reduced by allowing the card to remain at an environment of low humidity for about 24 hours. This will allow the condensed moisture to evaporate.
6. Should it become necessary to clean the board due to contamination, the following procedure should be followed:
 - A. The relay shield covers should be removed to expose all internal wiring before cleaning.
 - B. The recommended method of cleaning is spraying the board with a solvent such as Freon[®] TMS or TE. Care should be taken to be sure that the solvent is not contaminated before spraying it on the board. If necessary a small bristle brush can be used to remove flux, grease, etc.
 - C. After cleaning, the board should be allowed to return to ambient temperature and all traces of condensed moisture should be allowed to evaporate before any low level measurements are made.

3.3 TEST EQUIPMENT

Recommended test equipment is given in Table 1. Test equipment other than recommended may be substituted if specifications equal or exceed the stated characteristics.

3.4 PERFORMANCE VERIFICATION

1. The procedures necessary to verify that the Model 7058 is operating within its specifications are given in this section. The tests should be carried out in the environment stated in the specifications.
2. General Considerations—Due to the low levels of the signals to be measured in several of the tests the following considerations should be made:
 - A. Physical Layout—All triaxial test cables should be kept as still as possible to help minimize noise. Use of Model 7024-3 triaxial cable is recommended. This is especially important on the offset current, and impedance tests. In the shunt impedance and isolation tests it is necessary to make a power supply and/or an electrometer input connection to a triaxial cable. This can be accomplished by using a KI Model 7023 connector and carefully soldering the leads on to it. To help eliminate noise in such a setup, the connector and exposed leads should be enclosed in a shield.
 - B. Sequence of Measurements—The tests involving the application of high voltages to the card should be done after the tests involving low offset currents. This will eliminate false offset readings due to dielectric absorption.
3. Offset Current Test (See Figure 4).
 - A. Disconnect all leads from the input connectors on the Model 7058.
 - B. Connect the Model 7024-3 triaxial cable from one of the OUTPUT connectors on the Model 7058 to the input of the electrometer. Set the electrometer to the 10^{-11} A range, and zero check.
 - C. Insert the Model 7058 into the Model 705 mainframe and select the channel which is to be tested.
 - D. With the electrometer released from zero check, note the offset current long enough to allow the switching transients to decay and the current to stabilize. The offset current as indicated by the electrometer reading should be less than 1pA exclusive of noise.
 - E. The above procedure should be repeated for all 10 channels of the card and also the all off mode.
4. Signal Path Resistance (See Figure 5).
 - A. Set the Model 195 to the 20Ω range. Zero the Model 195 with the leads shorted.
 - B. Set up the circuit shown in Figure 5.
 - C. Install the Model 7058 into the mainframe and activate the channel to be tested.
 - D. The resistance reading on the Model 195 will indicate the HI signal path resistance.
 - E. Change the test leads to connect to the LO signal path.
 - F. Repeat the reading with the Model 195. This will indicate the LO signal path resistance. The sum of the HI signal path and LO signal path resistance should be less than 1Ω .
5. Shunt Impedance Test
 - A. Test Setup—Set up equipment as shown in Figure 6.
 - B. Turn the power supply on and select the channel to be tested.
 - C. Release the electrometer from the ZERO CHECK position. The current reading should be $<1 \times 10^{-8}$ A. This corresponds to a shunt resistance of

$$\frac{100V}{1 \times 10^{-8}A} = 10^{10}\Omega$$

D. This process should be repeated for all 10 channels and also with all relays off.

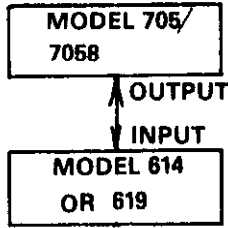

Figure 4. Test Set Up For Offset Current Test

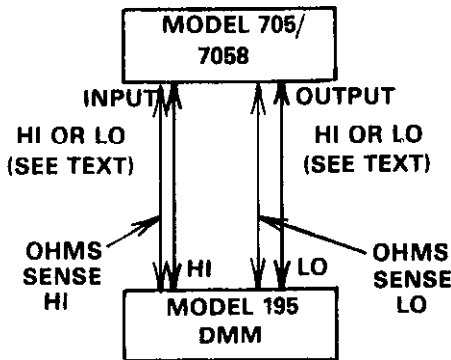

Figure 5. Test Set Up For Signal Path Resistance Test

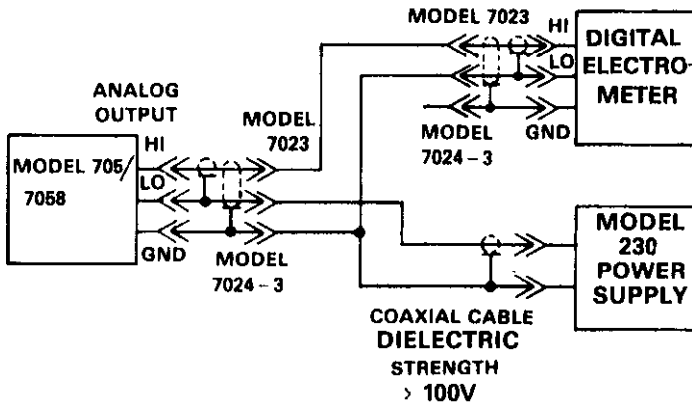

Figure 6. Test Set Up For Shunt Impedance Test

6. Relay Contact Timing Test

- A. Set up the Model 7058 in the mainframe as shown in Figure 7. Select channel 1.
- B. Turn the generator on and the oscilloscope to (+) trigger. The oscilloscope should be set as follows:
SWEEP: 1ms/division
VERTICAL SENSITIVITY: 5V/division
- C. Turn the power supply output on.
- D. The time until the first 10V to 0V transition on the display should be less than 6msec.
- E. The time for the contacts to completely close should be less than 6msec.
- F. Set the oscilloscope to (-) trigger.
- G. Verify that the time to the 0 to 10V transition is less than 1ms.
- H. Test all 10 channels as described in steps A through G.

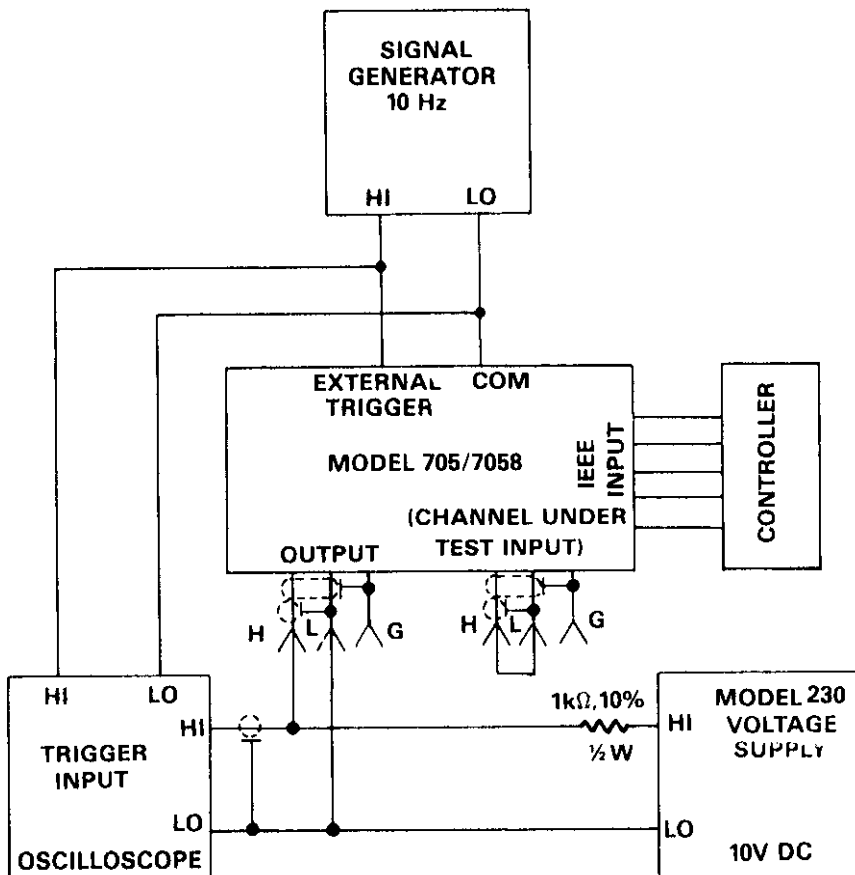

Figure 7. Test Set Up For Relay Timing Test

7. Channel Isolation

- A. This test measures the leakage resistance between two channels on the board. One channel is to be open and the other closed. Set up the test circuit shown in Figure 8.
- B. Short the HI and LO connections of each channel on the Model 7058. Do not connect the channels together, just short the HI and LO terminals.
- C. Set the Model 705 to the Channel mode, Channel 1 and the Step mode. Set the electrometer to Amps and program the Model 230 to output 100V.
- D. Take the electrometer out of ZERO CHECK. Program the channel under test as open and other channels as closed.
- E. Take the reading on the electrometer. The reading should be less than $1 \times 10^{-13} \text{A}$. Using Ohm's Law calculate the channel isolation. For example: $R = E/I = 100\text{V}/1 \times 10^{-13}\text{A} = 1 \times 10^{15}\Omega$. Due to the capacitance of the circuit, the offset current may be high until the capacitance of the circuit is charged up. Wait until the readings settle out.
- F. Manually scan through channels 1 through 10 repeating step D and E for each channel.

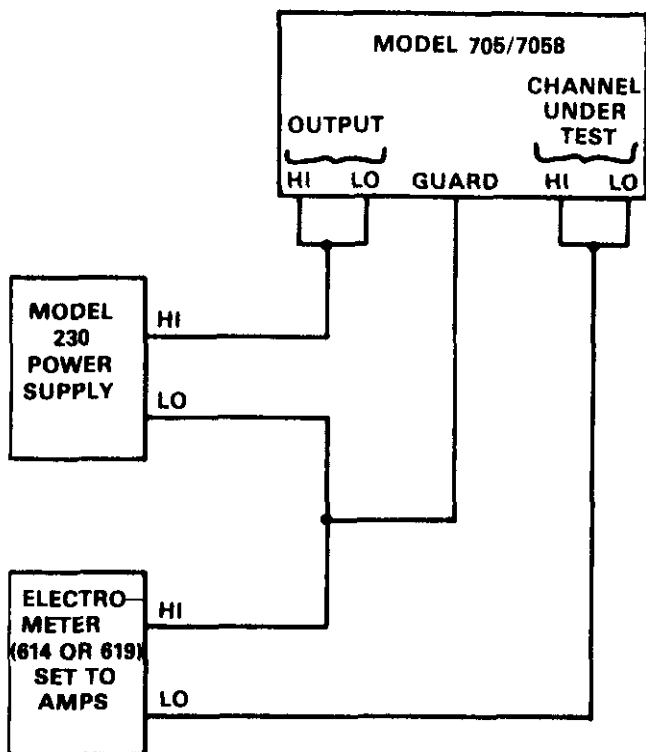

Figure 8. Channel Isolation Test Set Up

Table 1. Recommended Test Equipment

Item	Description	Specifications	Mfg.	Model
A	Electrometer	Sensitivity to 10^{-12} A	KI	614 or 619
B	Chart Recorder	1V full range	H-P	7035B
C	Scanner Mainframe		KI	705
D	Accessory Cable	Triaxial cable, 3 foot long	KI	7024-3
E	Ohmmeter-DMM	< 1Ω sensitivity	KI	195
F	Accessory Kelvin Leads		KI	1641
G	Accessory Connectors (2)	Triaxial connector	KI	1553
H	Power Supply	10.00VDC, 100VDC	KI	230
I	Oscilloscope	DC Coupled Trigger Sweep	Tek	7600 series
J	Square Wave Generator	10Hz	H-P	3310B
K	Accessory Triaxial Cables (2)	Triaxial with clip leads.	KI	6011
L	Triaxial Connector (Female)		KI	7023

SECTION 4 REPLACEABLE PARTS

4.1 INTRODUCTION

This section contains replacement parts information, a schematic diagram and component layout for the Model 7058.

4.2 REPLACEABLE PARTS

Parts are listed alpha-numerically in order of their circuit designation. Table 2 contains parts list information for the Model 7058.

4.3 ORDERING INFORMATION

To place an order, or to obtain information concerning replacement parts, contact your Keithley representative or the factory. See the inside front cover for addresses. When ordering include the following information:

1. Instrument Model Number
2. Instrument Serial Number
3. Part Description
4. Circuit Description (if applicable)
5. Keithley Part Number

4.4 FACTORY SERVICE

If the instrument is to be returned to the factory for service, please complete the service form which follows this section and return it with the instrument.

4.5 COMPONENT LAYOUT AND SCHEMATIC DIAGRAM

A component layout of the Model 7058 is contained in Figure 10, while Figure 11 contains a schematic diagram of the Model 7058.

Table 2. Model 7058 Replaceable Parts

Circuit Desig.	Description	Keithley Part No.
C101	Capacitor, 10 μ F, 25V, Aluminum Electrolytic	C-314-10
CR101	Silicon Diode, 1N914	RF-28
CR102	Silicon Diode, 1N914	RF-28
CR103	Silicon Diode, 1N914	RF-28
CR104	Silicon Diode, 1N914	RF-28
CR105	Silicon Diode, 1N914	RF-28
CR106	Silicon Diode, 1N914	RF-28
CR107	Silicon Diode, 1N914	RF-28
CR108	Silicon Diode, 1N914	RF-28
CR109	Silicon Diode, 1N914	RF-28
CR110	Silicon Diode, 1N914	RF-28
CR111	Silicon Diode, 1N914	RF-28
J1001	Connector, Triax (6 required)	CS-181
K101	Relay	RL-48

Table 2. Model 7058 Replaceable Parts (Cont.)

Circuit Desig.	Description	Keithley Part No.
K102	Relay	RL-48
K103	Relay	RL-48
K104	Relay	RL-48
K105	Relay	RL-48
K106	Relay	RL-48
K107	Relay	RL-48
K108	Relay	RL-48
K109	Relay	RL-48
K110	Relay	RL-48
K111	Relay	RL-48
Q101	Transistor, Silicon PNP, 2N4355	TG-90
R101	Resistor, 1k, 5%, 1/4W, Composition	R-76-1k
R102	Resistor, 1k, 5%, 1/4W, Composition	R-76-1k
	MECHANICAL PARTS	
	Bracket, Rear, Connector Mounting	27079
	Connector, Triax (6 required)	CS-181
	Shield	27076
	No. 4-40 × 3/16 Slot Fil Head Screw (20 required)	
	1/4" Flat Brass Washer (2 required)	
	No. 4-40 × 1/4 Nylon Slot Round Head Screw (4 required)	
	Bracket, Front, Connector, Mounting	27078
	Connector, Triax (6 required)	CS-181
	Shield	27076
	No. 4-40 × 3/16 Slot Fil Head Screw (20 required)	
	1/4" Flat Brass Washer (2 required)	
	No. 4-40 × 1/4 Nylon Slot Round Head Screw (4 required)	
	No. 4-40 × 3/16 Sems Slot Round Head Screw (6 required)	
	Staking, Front Relay Cover	7058-301
	A. Cover, Front Relay	7058-302
	B. Insulator	27072
	C. Standoff	27377
	Staking, Rear Panel Cover	7058-304
	A. Cover, Rear Panel	7058-305
	B. Insulator	27074
	C. Standoff	ST-129
	No. 6-32 × 1/4 Phillips Pan Head Screw (2 required)	
	Protective Cap (12 required)	CAP-18
	Test Lead	7024-3

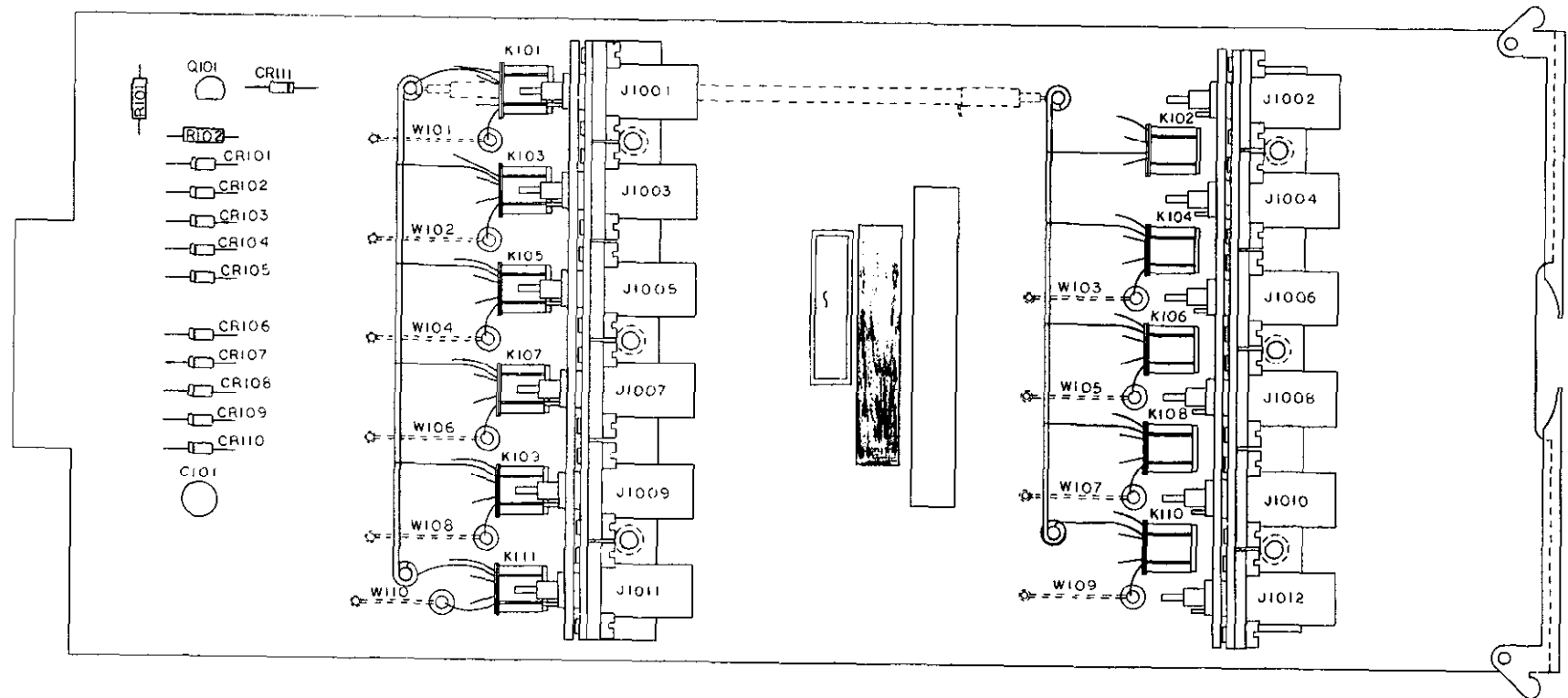

Figure 9. Model 7058 Component Location Drawing

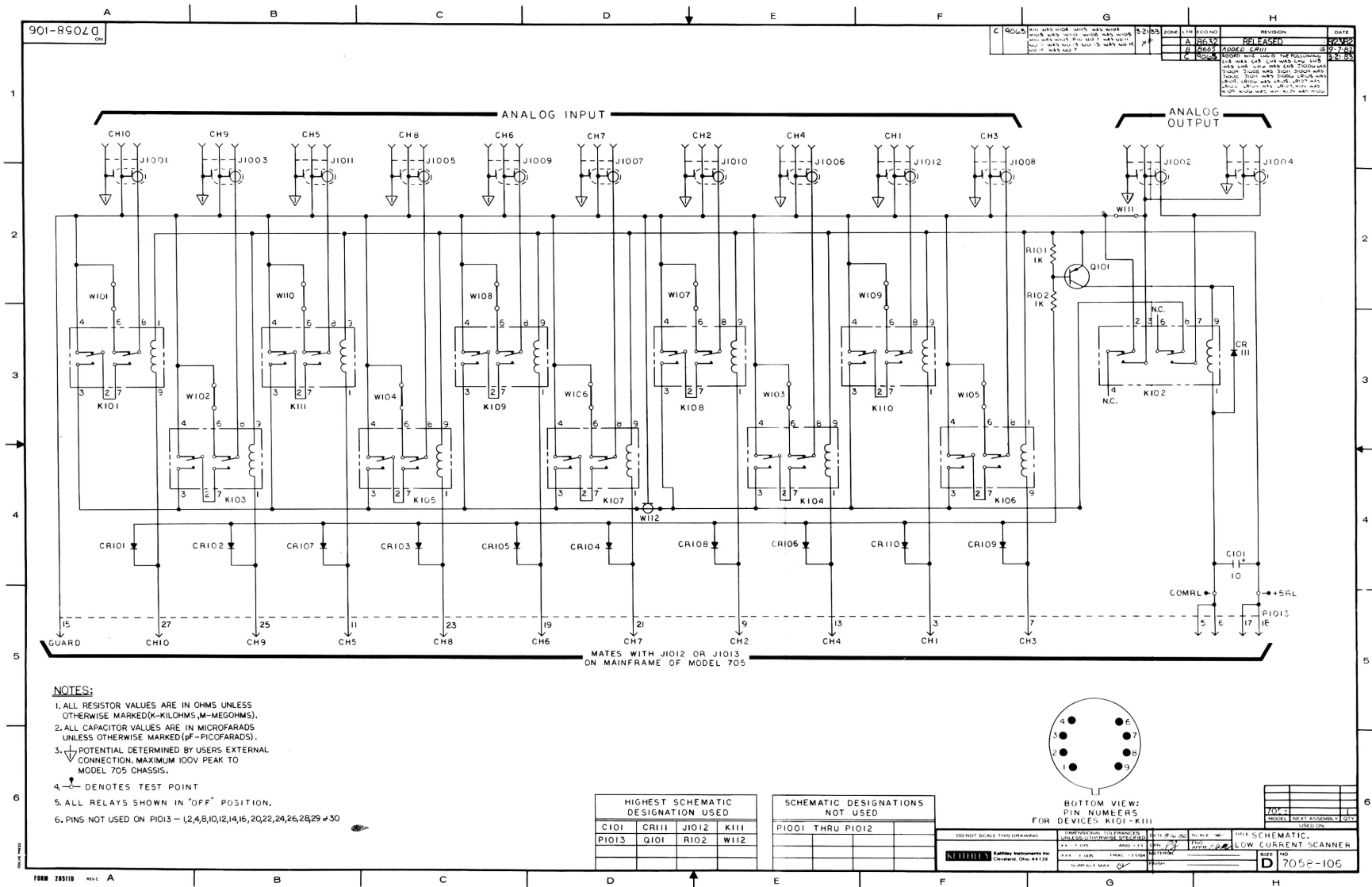

Figure 10. Model 7058 Schematic Diagram



Service Form

Model No. _____ Serial No. _____ Date _____

Name and Telephone No. _____

Company _____

List all control settings, describe problem and check boxes that apply to problem. _____

- | | | |
|--|--|--|
| <input type="checkbox"/> Intermittent | <input type="checkbox"/> Analog output follows display | <input type="checkbox"/> Particular range or function bad; specify _____ |
| <input type="checkbox"/> IEEE failure | <input type="checkbox"/> Obvious problem on power-up | <input type="checkbox"/> Batteries and fuses are OK |
| <input type="checkbox"/> Front panel operational | <input type="checkbox"/> All ranges or functions are bad | <input type="checkbox"/> Checked all cables |

Display or output (check one)

- | | |
|---|--|
| <input type="checkbox"/> Drifts | <input type="checkbox"/> Unable to zero |
| <input type="checkbox"/> Unstable | <input type="checkbox"/> Will not read applied input |
| <input type="checkbox"/> Overload | |
| <input type="checkbox"/> Calibration only | <input type="checkbox"/> Certificate of calibration required |
| <input type="checkbox"/> Data required | |

(attach any additional sheets as necessary)

Show a block diagram of your measurement system including all instruments connected (whether power is turned on or not). Also, describe signal source.

Where is the measurement being performed? (factory, controlled laboratory, out-of-doors, etc.) _____

What power line voltage is used? _____ Ambient temperature? _____ °F

Relative humidity? _____ Other? _____

Any additional information. (If special modifications have been made by the user, please describe.) _____

Be sure to include your name and phone number on this service form.

KEITHLEY

Keithley Instruments, Inc.
Test Instrumentation Group
28775 Aurora Road
Cleveland, Ohio 44139

Printed in the U.S.A.