

Model 7999-5  
RS-232 Relay Controller  
Instruction Manual

Contains Operating and Servicing Information

**KEITHLEY**

---

# WARRANTY

Keithley Instruments, Inc. warrants this product to be free from defects in material and workmanship for a period of 1 year from date of shipment.

Keithley Instruments, Inc. warrants the following items for 90 days from the date of shipment: probes, cables, rechargeable batteries, diskettes, and documentation.

During the warranty period, we will, at our option, either repair or replace any product that proves to be defective.

To exercise this warranty, write or call your local Keithley representative, or contact Keithley headquarters in Cleveland, Ohio. You will be given prompt assistance and return instructions. Send the product, transportation prepaid, to the indicated service facility. Repairs will be made and the product returned, transportation prepaid. Repaired or replaced products are warranted for the balance of the original warranty period, or at least 90 days.

## LIMITATION OF WARRANTY

This warranty does not apply to defects resulting from product modification without Keithley's express written consent, or misuse of any product or part. This warranty also does not apply to fuses, software, non-rechargeable batteries, damage from battery leakage, or problems arising from normal wear or failure to follow instructions.

THIS WARRANTY IS IN LIEU OF ALL OTHER WARRANTIES, EXPRESSED OR IMPLIED, INCLUDING ANY IMPLIED WARRANTY OF MERCHANTABILITY OR FITNESS FOR A PARTICULAR USE. THE REMEDIES PROVIDED HEREIN ARE BUYER'S SOLE AND EXCLUSIVE REMEDIES.

NEITHER KEITHLEY INSTRUMENTS, INC. NOR ANY OF ITS EMPLOYEES SHALL BE LIABLE FOR ANY DIRECT, INDIRECT, SPECIAL, INCIDENTAL OR CONSEQUENTIAL DAMAGES ARISING OUT OF THE USE OF ITS INSTRUMENTS AND SOFTWARE EVEN IF KEITHLEY INSTRUMENTS, INC., HAS BEEN ADVISED IN ADVANCE OF THE POSSIBILITY OF SUCH DAMAGES. SUCH EXCLUDED DAMAGES SHALL INCLUDE, BUT ARE NOT LIMITED TO: COSTS OF REMOVAL AND INSTALLATION, LOSSES SUSTAINED AS THE RESULT OF INJURY TO ANY PERSON, OR DAMAGE TO PROPERTY.



**Keithley Instruments, Inc.** • 28775 Aurora Road • Cleveland, OH 44139 • 440-248-0400 • Fax: 440-248-6168 • <http://www.keithley.com>

<b>BELGIUM:</b>	<b>Keithley Instruments B.V.</b>	Bergensesteenweg 709 • B-1600 Sint-Pieters-Leeuw • 02/363 00 40 • Fax: 02/363 00 64
<b>CHINA:</b>	<b>Keithley Instruments China</b>	Yuan Chen Xin Building, Room 705 • 12 Yumin Road, Dewai, Madian • Beijing 100029 • 8610-62022886 • Fax: 8610-62022892
<b>FRANCE:</b>	<b>Keithley Instruments Sarl</b>	B.P. 60 • 3, allée des Garays • 91122 Palaiseau Cédex • 01 64 53 20 20 • Fax: 01 60 11 77 26
<b>GERMANY:</b>	<b>Keithley Instruments GmbH</b>	Landsberger Strasse 65 • D-82110 Germering • 089/84 93 07-40 • Fax: 089/84 93 07-34
<b>GREAT BRITAIN:</b>	<b>Keithley Instruments Ltd</b>	The Minster • 58 Portman Road • Reading, Berkshire RG30 1EA • 0118-9 57 56 66 • Fax: 0118-9 59 64 69
<b>INDIA:</b>	<b>Keithley Instruments GmbH</b>	Flat 2B, WILOCRISSA • 14, Rest House Crescent • Bangalore 560 001 • 91-80-509-1320/21 • Fax: 91-80-509-1322
<b>ITALY:</b>	<b>Keithley Instruments s.r.l.</b>	Viale S. Gimignano, 38 • 20146 Milano • 02/48 30 30 08 • Fax: 02/48 30 22 74
<b>NETHERLANDS:</b>	<b>Keithley Instruments B.V.</b>	Postbus 559 • 4200 AN Gorinchem • 0183-635333 • Fax: 0183-630821
<b>SWITZERLAND:</b>	<b>Keithley Instruments SA</b>	Kriesbachstrasse 4 • 8600 Dübendorf • 01-821 94 44 • Fax: 01-820 30 81
<b>TAIWAN:</b>	<b>Keithley Instruments Taiwan</b>	1 Fl. 85 Po Ai Street • Hsinchu, Taiwan, R.O.C. • 886-3572-9077 • Fax: 886-3572-9031

---

# Model 7999-5 16-Channel RS-232 Relay Controller Instruction Manual

©1998, Keithley Instruments, Inc.  
All rights reserved.  
Cleveland, Ohio, U.S.A.  
Second Printing, December 1999  
Document Number: 7999-5-901-01 Rev. B

---

# Manual Print History

The print history shown below lists the printing dates of all Revisions and Addenda created for this manual. The Revision Level letter increases alphabetically as the manual undergoes subsequent updates. Addenda, which are released between Revisions, contain important change information that the user should incorporate immediately into the manual. Addenda are numbered sequentially. When a new Revision is created, all Addenda associated with the previous Revision of the manual are incorporated into the new Revision of the manual. Each new Revision includes a revised copy of this print history page.

Revision A (Document Number 7999-5-901-01).....	November 1999
Revision B (Document Number 7999-5-901-01).....	December 1999

---

# Safety Precautions

The following safety precautions should be observed before using this product and any associated instrumentation. Although some instruments and accessories would normally be used with non-hazardous voltages, there are situations where hazardous conditions may be present.

This product is intended for use by qualified personnel who recognize shock hazards and are familiar with the safety precautions required to avoid possible injury. Read the operating information carefully before using the product.

The types of product users are:

**Responsible body** is the individual or group responsible for the use and maintenance of equipment, for ensuring that the equipment is operated within its specifications and operating limits, and for ensuring that operators are adequately trained.

**Operators** use the product for its intended function. They must be trained in electrical safety procedures and proper use of the instrument. They must be protected from electric shock and contact with hazardous live circuits.

**Maintenance personnel** perform routine procedures on the product to keep it operating, for example, setting the line voltage or replacing consumable materials. Maintenance procedures are described in the manual. The procedures explicitly state if the operator may perform them. Otherwise, they should be performed only by service personnel.

**Service personnel** are trained to work on live circuits, and perform safe installations and repairs of products. Only properly trained service personnel may perform installation and service procedures.

Exercise extreme caution when a shock hazard is present. Lethal voltage may be present on cable connector jacks or test fixtures. The American National Standards Institute (ANSI) states that a shock hazard exists when voltage levels greater than 30V RMS, 42.4V peak, or 60VDC are present. **A good safety practice is to expect that hazardous voltage is present in any unknown circuit before measuring.**

Users of this product must be protected from electric shock at all times. The responsible body must ensure that users are prevented access and/or insulated from every connection point. In some cases, connections must be exposed to potential human contact. Product users in these circumstances must be trained to protect themselves from the risk of electric shock. If the circuit is capable of operating at or above 1000 volts, **no conductive part of the circuit may be exposed.**

As described in the International Electrotechnical Commission (IEC) Standard IEC 664, digital multimeter measuring circuits (e.g., Keithley Models 175A, 199, 2000, 2001, 2002, and 2010) are Installation Category II. All other instruments' signal terminals are Installation Category I and must not be connected to mains.

Do not connect switching cards directly to unlimited power circuits. They are intended to be used with impedance limited sources. NEVER connect switching cards directly to AC mains. When connecting sources to switching cards, install protective devices to limit fault current and voltage to the card.

Before operating an instrument, make sure the line cord is connected to a properly grounded power receptacle. Inspect the connecting cables, test leads, and jumpers for possible wear, cracks, or breaks before each use.

For maximum safety, do not touch the product, test cables, or any other instruments while power is applied to the circuit under test. ALWAYS remove power from the entire test system and discharge any capacitors before: connecting or disconnecting cables or jumpers, installing or removing switching cards, or making internal changes, such as installing or removing jumpers.

---

Do not touch any object that could provide a current path to the common side of the circuit under test or power line (earth) ground. Always make measurements with dry hands while standing on a dry, insulated surface capable of withstanding the voltage being measured.

The instrument and accessories must be used in accordance with its specifications and operating instructions or the safety of the equipment may be impaired.

Do not exceed the maximum signal levels of the instruments and accessories, as defined in the specifications and operating information, and as shown on the instrument or test fixture panels, or switching card.

When fuses are used in a product, replace with same type and rating for continued protection against fire hazard.

Chassis connections must only be used as shield connections for measuring circuits, NOT as safety earth ground connections.

If you are using a test fixture, keep the lid closed while power is applied to the device under test. Safe operation requires the use of a lid interlock.

If a  screw is present, connect it to safety earth ground using the wire recommended in the user documentation.

The  symbol on an instrument indicates that the user should refer to the operating instructions located in the manual.

The  symbol on an instrument shows that it can source or measure 1000 volts or more, including the combined effect of normal and common mode voltages. Use standard safety precautions to avoid personal contact with these voltages.

The **WARNING** heading in a manual explains dangers that might result in personal injury or death. Always read the associated information very carefully before performing the indicated procedure.

The **CAUTION** heading in a manual explains hazards that could damage the instrument. Such damage may invalidate the warranty.

Instrumentation and accessories shall not be connected to humans.

Before performing any maintenance, disconnect the line cord and all test cables.

To maintain protection from electric shock and fire, replacement components in mains circuits, including the power transformer, test leads, and input jacks, must be purchased from Keithley Instruments. Standard fuses, with applicable national safety approvals, may be used if the rating and type are the same. Other components that are not safety related may be purchased from other suppliers as long as they are equivalent to the original component. (Note that selected parts should be purchased only through Keithley Instruments to maintain accuracy and functionality of the product.) If you are unsure about the applicability of a replacement component, call a Keithley Instruments office for information.

To clean an instrument, use a damp cloth or mild, water based cleaner. Clean the exterior of the instrument only. Do not apply cleaner directly to the instrument or allow liquids to enter or spill on the instrument. Products that consist of a circuit board with no case or chassis (e.g., data acquisition board for installation into a computer) should never require cleaning if handled according to instructions. If the board becomes contaminated and operation is affected, the board should be returned to the factory for proper cleaning/servicing.

# Model 7999-5 Specifications

---

**OUTPUTS:** 16 open collector relay control lines, each capable of 300mA max. sink current. Coil suppression diodes included.

**OUTPUT SATURATION VOLTAGE:** 0.18V typ. @ 300mA.

**MAXIMUM RELAY POWER VOLTAGE:** 28V DC (user supplied).

**CONNECTORS:** Two 10-position quick disconnect terminal blocks.

**UPPER CONNECTOR:** Relay power, relay common, relay control outputs 1–8.

**LOWER CONNECTOR:** Relay power, relay common, relay control outputs 9–16.

The relay common of the upper and lower connectors is internally connected together to chassis ground.

The relay power inputs of the upper and lower connectors are separate, allowing two different coil voltages to be used for each bank.

## GENERAL

**INTERFACE:** RS-232 control (9600 baud, 8 data, 1 stop). Response terminator selectable (CR, LF, CRLF, LFCR).

**ENVIRONMENT: Operating:** 0° to 40°C, up to 35°C <80% RH. **Storage:** –25° to 65°C.

**POWER CONSUMPTION:** 7.3W.

**WARRANTY:** 1 year.

**EMC:** Conforms with European Union Directive 89/336/EEC, FCC part 15 class B.

**SAFETY:** Conforms with European Union Directive 73/23/EEC.

**DIMENSIONS:** 109mm long × 112mm wide × 59mm deep (4.3" × 4.4" × 2.3").

**ACCESSORIES SUPPLIED:** AC/DC power adapter (100–120VAC/ 220–240VAC, 50 or 60Hz) with line cord, user and service manual, two terminal block mating connectors (part no. CS-846-1).

Specifications subject to change without notice.

---

# Table of Contents

<b>1</b>	<b>General Information</b>	
	Introduction .....	1-2
	Feature overview .....	1-2
	Warranty information .....	1-2
	Manual addenda .....	1-2
	Safety symbols and terms .....	1-3
	Specifications .....	1-3
	Unpacking and inspection .....	1-3
	Inspection for damage .....	1-3
	Handling precautions .....	1-3
	Shipment contents .....	1-4
	Instruction manual .....	1-4
	Repacking for shipment .....	1-4
	Connections .....	1-4
<b>2</b>	<b>Connections</b>	
	Introduction .....	2-2
	Handling precautions .....	2-2
	Configuration .....	2-3
	Layout .....	2-3
	Connections .....	2-4
	RS-232 connection .....	2-4
	Power connector .....	2-5
	Quick disconnect connections .....	2-5
<b>3</b>	<b>Operation</b>	
	Introduction .....	3-2
	Maximum voltage and current considerations .....	3-2
	Operation (RS-232) .....	3-2
	Sending and receiving data .....	3-2
	Termination characters .....	3-2
	RS-232 command set .....	3-4
	Command interpretation .....	3-5
	Typical connection scheme .....	3-7
<b>4</b>	<b>Service Information</b>	
	Introduction .....	4-2
	Handling and cleaning precautions .....	4-2
	Handling precautions .....	4-2
	Card and connector cleaning .....	4-2



---

Replacing components .....	4-3
Replacement parts .....	4-3
Replacement precautions .....	4-3
Soldering considerations .....	4-3
Disassembly .....	4-3
Performance verification .....	4-4
Environmental conditions .....	4-4
Recommended equipment .....	4-4
Output saturation voltage verification procedure .....	4-5

## **5      Replaceable Parts**

Introduction .....	5-2
Parts list .....	5-2
Ordering information .....	5-2
Factory service .....	5-2
Component layout .....	5-2

---

## List of Illustrations

<b>2</b>	<b>Connections</b>	
Figure 2-1	General layout .....	2-3
Figure 2-2	RS-232 interface connector .....	2-4
Figure 2-3	Relay control connector pinouts .....	2-6
<b>3</b>	<b>Operation</b>	
Figure 3-1	Jumper location .....	3-3
Figure 3-2	Typical connection scheme .....	3-7
<b>4</b>	<b>Service Information</b>	
Figure 4-1	Output saturation voltage test connections .....	4-5

---

## List of Tables

<b>2</b>	<b>Connections</b>	
Table 2-1	RS-232 connector terminals .....	2-4
Table 2-2	Upper relay connector pinouts .....	2-5
Table 2-3	Lower relay connector pinouts .....	2-6
<b>3</b>	<b>Operation</b>	
Table 3-1	Jumper positions—termination characters .....	3-3
Table 3-2	Command set .....	3-4
Table 3-3	Sample command interpretation .....	3-6
<b>4</b>	<b>Service Information</b>	
Table 4-1	Recommended verification equipment .....	4-4
<b>5</b>	<b>Replaceable Parts</b>	
Table 5-1	Parts list—electronic components .....	5-3
Table 5-2	Parts list—mechanical parts .....	5-4

# General Information

---

# Introduction

This section contains general information about the Model 7999-5 16-channel RS-232 relay controller. The information is organized as follows:

- Feature overview
- Warranty information
- Manual addenda
- Safety symbols and terms
- Specifications
- Unpacking and inspection
- Connections

If you have any questions after reviewing this information, please contact your local Keithley representative or call a Keithley Applications Engineer at 1-800-348-3735 (U.S. and Canada only). Worldwide phone numbers are listed at the front of this manual.

# Feature overview

The Model 7999-5 is a 16-channel open collector relay controller with the following features:

- 16 open-collector relay control lines
- Quick-disconnect terminal block type connectors (mating connectors supplied)
- Coil suppression diodes

# Warranty information

Warranty information is located at the front of this instruction manual. Should your Model 7999-5 require warranty service, contact the Keithley representative or authorized repair facility in your area for further information. When returning the relay controller for repair, be sure to fill out and include the service form at the back of this manual to provide the repair facility with the necessary information.

# Manual addenda

Any improvements or changes concerning the relay controller or manual will be explained in an addendum included with the manual. Be sure to note these changes and incorporate them into the manual.

## Safety symbols and terms

The following symbols and terms may be found on the relay controller or used in this manual.

The  symbol indicates that the user should refer to the operating instructions located in the manual.

The  symbol shows that high voltage may be present on the terminal(s). Use standard safety precautions to avoid personal contact with these voltages.

The **WARNING** heading used in this manual explains dangers that might result in personal injury or death. Always read the associated information very carefully before performing the indicated procedure.

The **CAUTION** heading used in this manual explains hazards that could damage the relay controller. Such damage may invalidate the warranty.

## Specifications

Full Model 7999-5 specifications are included at the front of this manual.

## Unpacking and inspection

### Inspection for damage

The Model 7999-5 is packaged in a re-sealable, anti-static bag to protect it from damage due to static discharge and from contamination that could degrade its performance. Before removing the relay controller from the bag, observe the precautions on handling discussed below.

### Handling precautions

- Always grasp the relay controller by the covers. Do not touch board surfaces or components.
- After removing the relay controller from its anti-static bag, inspect it for any obvious signs of physical damage. Report any such damage to the shipping agent immediately.
- When the relay controller is not installed and connected, keep the relay controller in its anti-static bag, and store it in the original packing carton.

## Shipment contents

The following items are included with every Model 7999-5 order:

- Model 7999-5 16-channel relay controller
- PS-57A Power supply module (AC/DC converter 100-240VAC to 12VDC, IEC AC inlet)
- Two 10-pin terminal block mating connectors
- Model 7999-5 Instruction Manual (this manual)
- Additional accessories as ordered

## Instruction manual

If an additional Model 7999-5 Instruction Manual is required, order the manual package, Keithley part number 7999-5-901-00. The manual package includes an instruction manual and any pertinent addenda.

## Repacking for shipment

Should it become necessary to return the Model 7999-5 for repair, carefully pack the unit in its original packing carton or the equivalent, and include the following information:

- Call the Repair Department at 1-888-KEITHLEY for a Return Material Authorization (RMA) number.
- Advise as to the warranty status of the relay controller.
- Write ATTENTION REPAIR DEPARTMENT and the RMA number on the shipping label.
- Fill out and include the service form located at the back of this manual.

## Connections

The following are available Model 7999-5 connections:

- Two 10-position quick-disconnect connectors
- Power receptacle: 3-pin phoenix jack for supplied power module
- RS-232 port: DB-9 connector

**NOTE** Refer to Section 2 for detailed connection information.

**2**

# Connections

---



## Introduction

This section contains information about overall relay controller configuration and connections and is organized as follows:

- Handling precautions
- Configuration
- Connections

## Handling precautions

Care should be taken when handling the relay controller to avoid contamination from such foreign materials as body oils. Such contamination can reduce isolation resistance. To avoid possible contamination:

- Always grasp the relay controller by the case.
- Do not touch connector insulators.
- Operate the relay controller in a clean environment. If the relay controller becomes contaminated, it should be thoroughly cleaned as explained in Section 4.

# Configuration

## Layout

Figure 2-1 shows the general layout of the Model 7999-5 which features:

Connectors:

- Power receptacle: 3-pin phoenix jack for supplied power module
- RS-232 port: DB-9 connector
- Two 10-pin quick disconnect connectors

Indicators:

- Power LED

**Figure 2-1**  
*General layout*

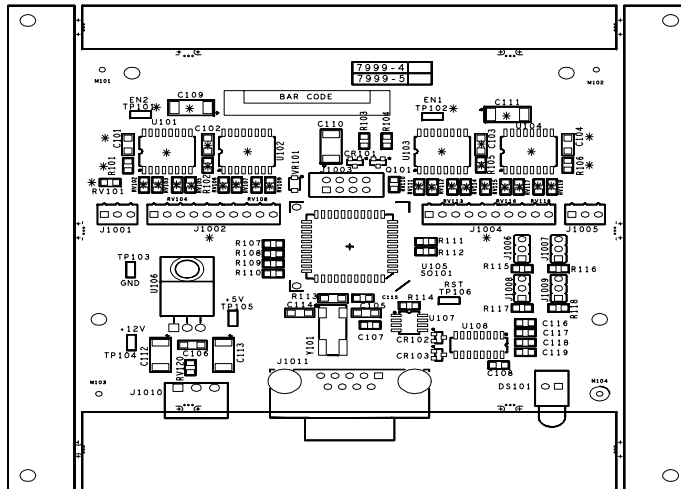

# Connections

## RS-232 connection

The RS-232 serial port is connected to the serial port of a computer (controller) using a straight-through RS-232 cable terminated with DB-9 connectors. Do not use a null modem cable. The serial port uses the transmit (TXD), receive (RXD), and signal ground (GND) line of the RS-232 standard. Figure 2-2 shows the Model 7999-5 connector with Table 2-1 containing the pinouts for the connector.

If your computer uses a DB-25 connector for the RS-232 interface, an additional cable or adapter (DB-25 to DB-9) is required.

**NOTE** *In the RS-232 interface, only pins 2, 3, and 5 are used. Pins 7 and 8 are tied together, but not connected to the circuit board. Pins 1, 4, and 6 are also tied together and not connected to the circuit board.*

**Table 2-1**  
RS-232 connector terminals

Pin number	Description
1	Tied to pins 4 and 6
2	TXD, Transmit data
3	RXD, Receive data
4	Tied to pins 1 and 6
5	GND, Signal ground
6	Tied to pins 1 and 4
7	Tied to pin 8
8	Tied to pin 7
9	Not used

**Figure 2-2**  
RS-232 interface connector

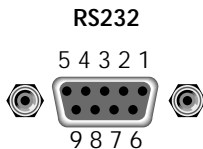

## Power connector

Connect the supplied power adapter (Model PS-57A) to the power connector.

**CAUTION** To prevent damage to the Model 7999-5, use only the Keithley Model PS-57A AC/DC power adapter. This is a universal input (100V-240VAC, 50/60Hz), 12VDC output (3A or less) supply.

## Quick disconnect connections

**CAUTION** Each relay control line is capable of sinking up to a maximum of 300mA with the maximum relay power voltage of 28VDC.

Two 10-position quick disconnect terminal blocks provide for relay control connections. The upper connector is for relay control outputs 1–8, while the lower connector is for relay control outputs 9–16. The relay common of both the upper and lower connector are connected to chassis ground while the power connections for each connector are separate. The control outputs are protected by coil suppression diodes (suppresses voltage spikes when relay coil is de-energized). Refer to Table 2-2, Table 2-3, and Figure 2-3 for connector pinouts.

**Table 2-2**

*Upper relay connector pinouts*

Pin number	Description
1	Relay power connection
2	Relay control output 1
3	Relay control output 2
4	Relay control output 3
5	Relay control output 4
6	Relay control output 5
7	Relay control output 6
8	Relay control output 7
9	Relay control output 8
10	Chassis ground connection

**Table 2-3**  
Lower relay connector pinouts

Pin number	Description
1	Relay power connection
2	Relay control output 16
3	Relay control output 15
4	Relay control output 14
5	Relay control output 13
6	Relay control output 12
7	Relay control output 11
8	Relay control output 10
9	Relay control output 9
10	Chassis ground connection

**Figure 2-3**  
Relay control  
connector pinouts

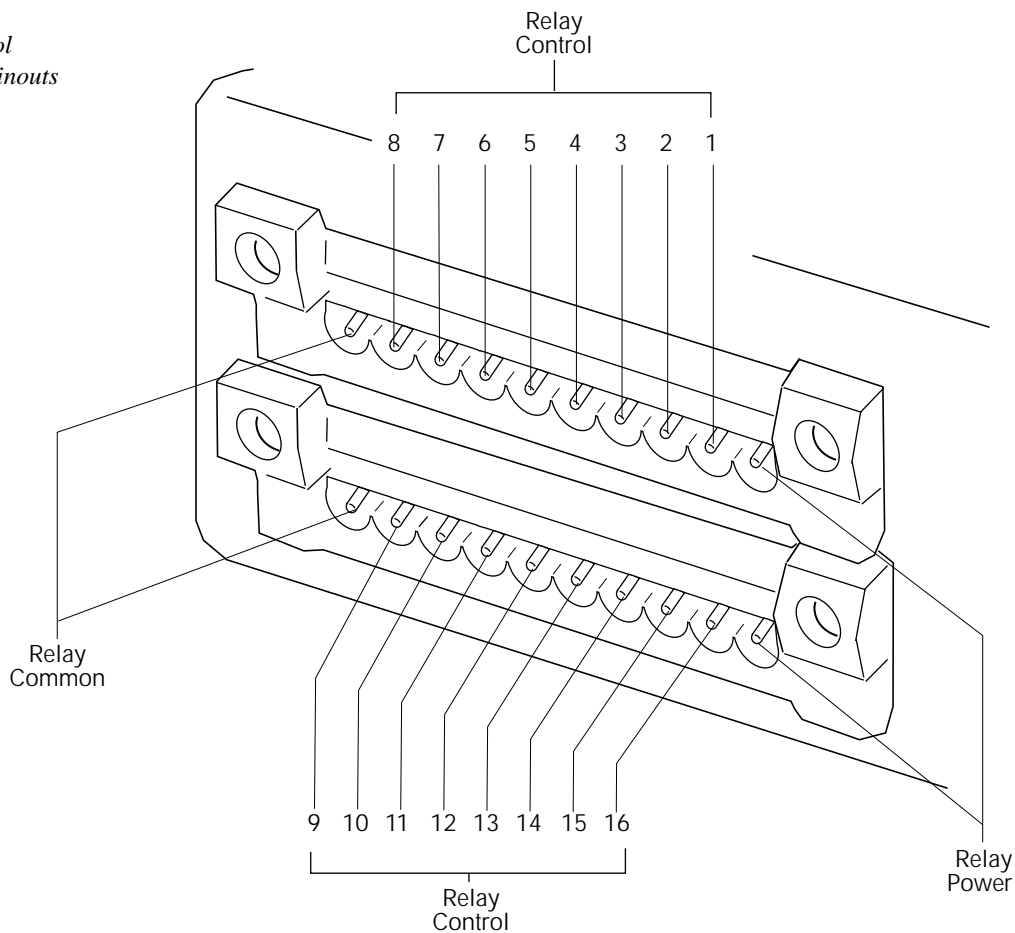

# 3 Operation

---

# Introduction

This section contains operating information for the Model 7999-5. The information is organized as follows:

- Maximum voltage and current considerations
- Operation (RS-232)

## Maximum voltage and current considerations

**WARNING** Maximum voltage between any conductor and ground is 42V.

**CAUTION** To prevent damage to the Model 7999-5, do not exceed the following maximum specifications:

- Maximum relay coil voltage: 28VDC
- Maximum current: 300mA maximum sink current per relay

## Operation (RS-232)

### Sending and receiving data

The Model 7999-5 relay controller is RS-232 controlled. Before the relays can be controlled, connect an appropriate and properly configured controller to the DB-9 port. The Model 7999-5 serial interface (RS-232) transfers data using eight data bits, no parity, and one stop bit (8-N-1). The interface also transfers data at 9600 baud. Make sure that the controller selected also uses these settings.

The relay controller can provide one of four different termination characters to the RS-232 controller (see “Termination characters”). The relay controller can receive any valid termination character sent by the RS-232 controller (line feed and/or carriage return).

### Termination characters

The Model 7999-5 can be configured to terminate each program message transmitted to the controller with any of the following combinations of <CR> or <LF>:

- <CR> Carriage return (factory default setting)
- <CR+LF> Carriage return and line feed
- <LF> Line feed
- <LF+CR> Line feed and carriage return

To configure the termination character, change the jumpers for PA6 (J1006) and PA7 (J1008) located on the Model 7999-5 printed circuit board. Refer to Figure 3-1 and Table 3-1 for jumper details. Refer to the first three steps of disassembly information in Section 4 to access the circuit board.

**NOTE** Changing the jumper settings sets the termination characters sent by the Model 7999-5 to the RS-232 controller. Any valid termination character sent by the RS-232 controller can be received by the Model 7999-5 (line feed and/or carriage return). The send and receive termination characters do not have to match.

**Figure 3-1**  
Jumper location

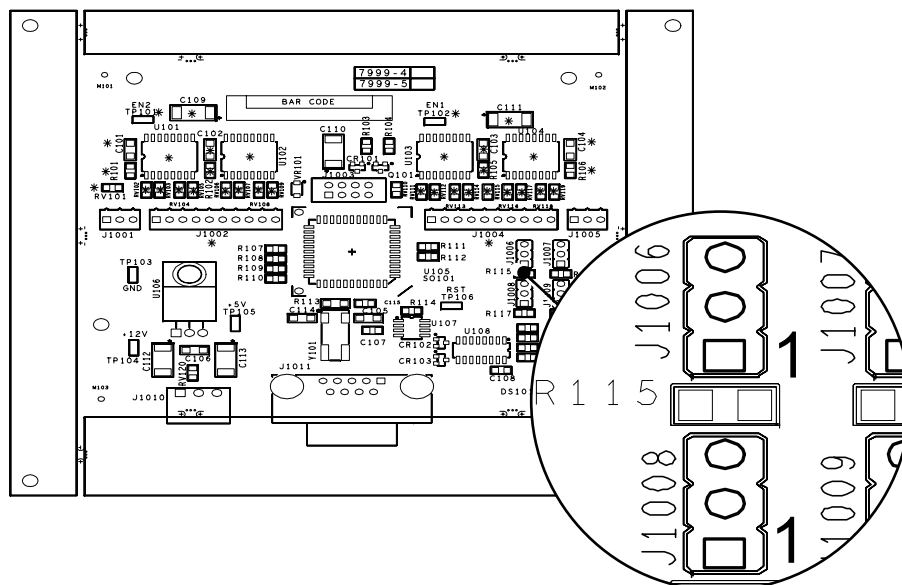

**Table 3-1**  
Jumper positions—termination characters

Terminator	J1006 pins	J1008 pins
<CR> <sup>1</sup>	1 and 2 <sup>1</sup>	1 and 2 <sup>1</sup>
<CR+LF>	2 and 3	1 and 2
<LF>	1 and 2	2 and 3
<LF+CR>	2 and 3	2 and 3

<sup>1</sup>Factory default setting



## RS-232 command set

**NOTE** ASCII characters not included in the command set are ignored.

Refer to Table 3-2 for list of commands included in the command set.

**Table 3-2**  
Command set

ASCII Command	Parameter Type	Description
A or a	None	Opens all relays. After all relays are opened and the delay occurs (the delay is relay settling time—see ASCII Command “D”), an ASCII “1” is sent over the RS-232 bus indicating the settling time has expired. Response must be “on” to send the “1” (see ASCII command R).
C or c	<list>	Closes specified relay(s). After this command is sent and a termination character is received from the RS-232 controller, the relay(s) close(s) and a delay occurs (the delay is relay settling time—see ASCII Command “D”). After the relay settling time expires, an ASCII “1” is sent over the RS-232 indicating settling time has expired. Response must be “on” to send the “1” (see ASCII command R).
D or d	<delay>	Sets the variable relay settling time (delay) in milliseconds (msec). This is the delay occurring after a command is issued that allows the relays to change state. Commands that use this delay are the A, C, and O commands. The default for this command is 15msec. Sending this command without a parameter queries the delay time.
I or i	None	Returns firmware information. This command retrieves firmware information over the RS-232. After the command is sent, “Keithley Instruments Inc., Model 7999-5, rev A01” (or similar, due to firmware revision level) will be returned over the RS-232.
O or o	<list>	Opens specified relay. After the open command is sent and the termination character is received from the RS-232 controller, the relay(s) open(s) and a delay occurs (the delay is relay settling time—see ASCII Command “D”). After the relay settles, an ASCII “1” is sent over the RS-232 indicating settling time has expired. Response must be “on” to send the “1” (see ASCII command R).
<list> Comma separated relay list with values from 1–16 <delay> 1–250ms <b> <0, 1> where 0 = OFF and 1 = ON		

**Table 3-2 (Continued)**

Command set

ASCII Command	Parameter Type	Description
Q or q	1–16	Queries for a single relay setting. The parameter specifies the relay. If the queried relay is open, an ASCII 0 will be returned. If the queried relay is closed, an ASCII 1 will be returned. If an invalid relay number is sent, or invalid parameter received (including no parameter), then an ASCII “?” is returned.
R or r	<b>	Response after delay (the delay is relay settling time—see ASCII Command “D”). This response occurs when using the A, C, and O commands. The default for this command is 1 (on). Sending this command without parameters queries the response state (if a 1 is returned, the response is on, if a 0 is returned, the response is off).
S or s	None	Queries all closed relays. Upon receiving this command, a comma separated list in ASCII will be returned indicating the closed relays. If no relays are closed, a comma will be returned.
<list> Comma separated relay list with values from 1–16 <delay> 1–250ms <b> <0, 1> where 0 = OFF and 1 = ON		

## Command interpretation

The Model 7999-5 requires each command to end with a termination character.

On a single line, the first valid ASCII character is interpreted as the command. The remaining characters are interpreted as the parameter data. This parameter data processing continues up to the termination character. When the termination character is received, the command is performed. Therefore, end each command with a termination character (line feed and/or carriage return) before sending a new command.

While processing the parameter data, if an ASCII character is invalid, it is ignored. Finding an invalid character does not abort the parameter data from being processed.

Leading zeros contained in the parameter list for the C, O, and Q commands are ignored. The parameter processing starts with the first non-zero digit and continues one additional digit. Commas separate each individual parameter until a termination character. Leading zeros contained in the parameter data are also ignored for the D command. The parameter processing starts with the first non-zero digit but continues two additional digits. Values interpreted as greater than 250 are set to 250. The D command issued without parameters (or with a “0”, which is ignored) issues a query.

Refer to Table 3-3 for command interpretation samples.

**NOTE** In the following samples (Table 3-3), <term> represents a valid termination character (line feed and/or carriage return).

The sample commands shown (the “ASCII characters sent,” e.g., C1,02 <term>, etc.,) assume they are the first command sent or the first command sent after a valid termination character.

Termination characters issued by the Model 7999-5 do not have to match the termination characters issued by the RS-232 control computer. Any valid termination character can be received by the Model 7999-5 (line feed and/or carriage return).

**Table 3-3**  
Sample command interpretation

ASCII characters sent	Response
C1,02 <term>	Relays 1 and 2 are closed. The O(pen) is ignored because, even though it is a valid command (after a termination character), it is an invalid parameter for the C(losed) command. 1 and 2 are interpreted for the parameter list.
O1, C2, Q4 <term>	Relay 1, 2, and 4 are opened. The C(losed) and Q(uey) are ignored because they are invalid parameters to the O(pen) command, while 1, 2, and 4 are interpreted for the parameter list.
Q1;Q4 <term>	Relay 14 is queried. The 2nd Q(uey) command along with the “;” are ignored because they are invalid parameters to the Q(uey) command, while the 1 and 4 are interpreted as a 14 for the parameter.
O2, 3,	Relays 2 and 3 are opened when a termination character is received (a termination character in addition to the ASCII characters shown at the left has to be sent for the command to be performed). Since no termination character has been sent, parameters can still be added to the list.
C102 <term>	Relay 12 is closed. The O(pen) command is ignored because it is an invalid parameter to the C(losed) command.
Q1,6 <term>	Relay 16 is queried. The comma is ignored because it is an invalid character for the Q(uey) command (the command does not accept a parameter list).
D008 <term>	Delay is set to 8msec. If queried, a response of 008 is returned.
D0325 <term>	Delay is set to 250msec (maximum value). If queried, a response of 250 is returned.

## Typical connection scheme

**WARNING** Relay contacts switching > 42 Vpk must be double insulated from relay coils.

Figure 3-2 is a simplified schematic of a typical connection scheme. Although relay power for each connector (upper and lower) can be provided from separate sources, both connectors share a common chassis ground.

**Figure 3-2**  
Typical connection scheme

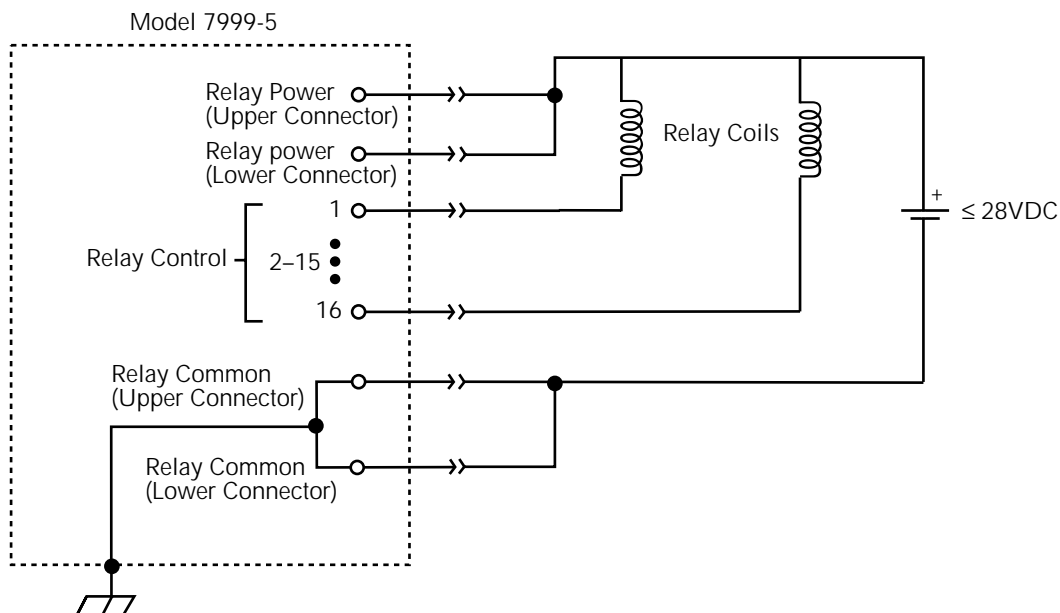



4

# Service Information

---

# Introduction

This section contains service information for the Model 7999-5. The information is organized as follows:

- Handling and cleaning precautions
- Performance verification
- Component replacement

**WARNING** The information in this section is intended only for qualified service personnel. Some of the procedures may expose you to hazardous voltages that could result in personal injury or death. Do not perform these procedures unless you are qualified to do so.

## Handling and cleaning precautions

Care should be taken when handling or servicing the relay controller to prevent possible contamination. The following precautions should be observed when servicing the relay controller.

### Handling precautions

Observe the following precautions when handling the relay controller:

- Handle the relay controller only by the edges and cover.
- Do not touch any board surfaces or components not associated with the repair.
- Do not store or operate the relay controller in an environment where dust could settle on the circuit board.

### Card and connector cleaning

- Use dry nitrogen gas to clean any dust off the circuit board and components.
- Clean the contaminated area with methanol, then blow dry the entire board with dry nitrogen gas.
- Before use, allow items cleaned to dry for several hours in a 50°C low-humidity environment. Use dry nitrogen to decrease drying time.

---

# Replacing components

## Replacement parts

Replacement parts can be obtained directly from Keithley Instruments, Inc. See the parts list in Section 5 for part numbers.

## Replacement precautions

**CAUTION** Observe the following precautions when replacing components:

- **To avoid contamination, which could degrade relay controller performance, always handle the relay controller only by the covers and side edges. Do not touch the connector, board surfaces, or components on the relay controller.**
- **Use care when working with components from the PC board to avoid pulling traces away from the circuit board.**

## Soldering considerations

When using solder on the circuit board, observe the following precautions:

- Use an OA-based (organic activated) flux, and take care not to spread the flux to other areas of the circuit board.
- Remove the flux from the work areas when the repair has been completed. Use pure water along with clean cotton swabs or a clean soft brush to remove the flux.
- Once the flux has been removed, swab only the repaired area with methanol, then blow dry the board with dry nitrogen gas.
- After cleaning, allow the card to dry in a 50°C low-humidity environment for several hours before use.

## Disassembly

Perform the following steps to disassemble the Model 7999-5 to gain access to parts on the circuit board:

1. Remove the six screws that hold the case together and any hex-nuts on the connectors.
2. Separate the two halves of the case.
3. Unplug the connectors from the board (J1004 and J1002).
4. Remove the screws that secure the PC board to the case, then remove the board.



## Performance verification

The following paragraphs discuss performance verification procedures for the Model 7999-5 and include an output saturation voltage verification procedure.

**CAUTION** Contamination will degrade the performance of the relay controller. To avoid contamination, always grasp the relay controller by the cover; do not touch the connectors.

**NOTE** Failure of any performance verification test may indicate that the multiplexer relay controller is contaminated. See “Handling and cleaning precautions” earlier in this section for information on cleaning the relay controller.

## Environmental conditions

All verification measurements should be made at an ambient temperature between 18° and 28°C, and at a relative humidity of less than 70%.

## Recommended equipment

Table 4-1 summarizes the equipment necessary for performance verification (channel resistance tests).

**Table 4-1**  
Recommended verification equipment

Manufacturer/Model	Equipment Description	Specifications
Keithley 2010	Digital Multimeter	DCV
Keithley 1681	Test Lead Set	Banana plug/clips
No recommendations	28VDC power supply	Nominal 28V @ 300mA (minimum)

## Output saturation voltage verification procedure

Perform the following steps to verify that the relay control lines output saturation voltage is within specification.

**WARNING** Use care around the resistor used in this test—the resistor will heat. Make sure to take adequate precautions to avoid burns when disconnecting and connecting the resistor.

1. Turn on the Model 2010 DMM, and allow it to warm up for one hour before making measurements.
2. Connect a 100Ω, 10W resistor between the relay control line under test (start with line 1 and work through line 16) and the 28VDC power supply (see Figure 4-1).
3. Set the Model 2010 DMM for voltage (DCV) and connect the two test leads to the INPUT HI and LO terminals.
4. Connect the Model 2010 DMM test leads as shown in Figure 4-1. Connection is made to relay control line under test and relay common.
5. Turn on the relay control line under test's output (see Section 3 for operation information).
6. Measure voltage. Using the setup described in this procedure, the voltage measurement will be made at the relay control line. Acceptable saturation voltage should be  $\leq 0.18\text{VDC}$ .
7. Repeat the procedure for the other relay control lines (2–16).

**Figure 4-1**

Output saturation voltage test connections

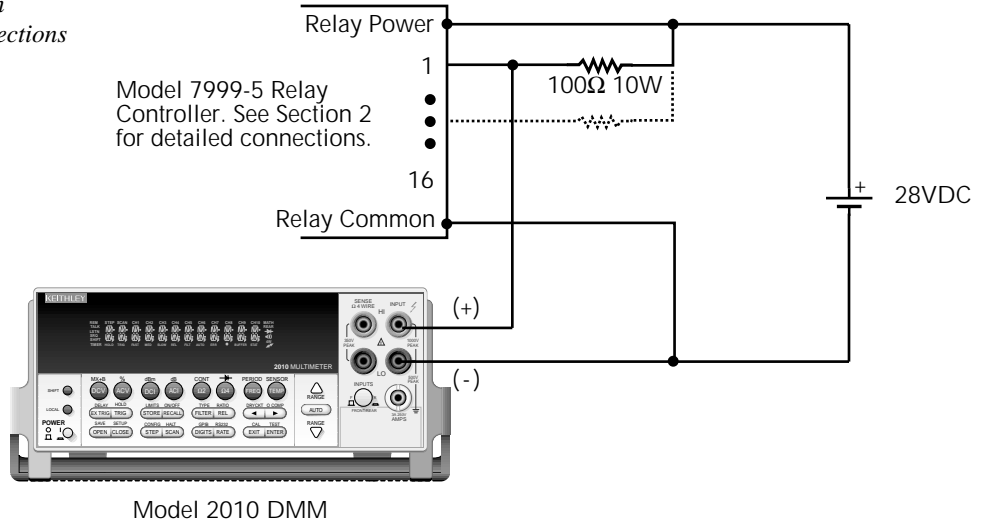



# 5

## Replaceable Parts

---

## Introduction

This section contains replacement parts information and also a component layout for the Model 7999-5.

## Parts list

Parts lists for the Model 7999-5 are contained in Table 5-1 and Table 5-2.

## Ordering information

To place an order, or to obtain information concerning replacement parts, contact your Keithley representative or the factory (see front of manual for addresses). When ordering parts, be sure to include the following information:

- Model number (Model 7999-5)
- Serial number
- Part description
- Component designation (if applicable)
- Keithley part number

## Factory service

If the relay controller is to be returned to Keithley Instruments for repair, perform the following:

- Call the Repair Department at 1-888-KEITHLEY for a Return Material Authorization (RMA) number.
- Complete the service form at the back of this manual, and include it with the instrument.
- Carefully pack the instrument in the original packing carton.
- Write ATTENTION REPAIR DEPARTMENT and the RMA number on the shipping label.

## Component layout

Component layout drawing (7999-5-100) is provided following parts list tables.

**Table 5-1***Parts list—electronic components*

<b>Circuit designation</b>	<b>Description</b>	<b>Keithley part number</b>
C101, C102, C103, C104, C106	CAP, 0.1UF, 20%, 50V, CERAMIC	C-418-.1
C105, C114	CAP, 33PF, 10%, 100V, CERAMIC	C-451-33P
C107, C108, C115, C116, C117, C118, C119	CAP, 0.1UF, 10%, 25V, CERAMIC	C-495-.1
C109, C111	CAP, 22UF, 20%, 25V, TANTALUM	C-440-22
C112, C113	CAP, 10UF, 20%, 25V, TANTALUM	C-440-10
CR102, CR103	DIODE, DUAL SWITCHING	RF-82
DS101	PILOT LIGHT, GREEN, LED	PL-78
J1002, J1004	LATCHING HEADER, FRICTION, SINGLE ROW	CS-724-10
J1006, J1008, J1009	CONN, BERG	CS-339
J1006, J1008, J1009	CONNECTOR, JUMPER	CS-476
J1010	CONN, HORIZ, RECEPTACLE, 3-PIN	CS-943-3
J1011	CONN, RT ANGLE, MALE, 9-PIN	CS-761-9
R101, R102, R105, R106	RES, 150K, 1%, 100mW, THICK FILM	R-418-150K
R103, R107-R110, R115-R118	RES, 10K, 1%, 100mW, THICK FILM	R-418-10K
R104	RES, 4.02K, 1%, 100mW, THICK FILM	R-418-4.02K
R111, R112, R114	RES, 4.75K, 1%, 100mW, THICK FILM	R-418-4.75K
R113	RES, 10M, 5%, 125mW, METAL FILM	R-375-10M
RV101-109, RV111-119	TRANSIENT VOLTAGE SUPPRESSOR	VR-12
RV 120	TRANSIENT VOLTAGE SUPPRESSOR	VR-11
RV 121	300M TRANSIENT VOLTAGE SUPPRESSOR ARRAY	VR-13
SO101	SOCKET	SO-143-44
TP101, TP102, TP103, TP104, TP105, TP106	SURFACE MOUNT PCB TEST POINT	CS-1026
U101, U102, U103, U104	IC, QUAD LOW SIDE DRIVER	IC-1351
U105	IC, 8-BIT MICRO PROCESSOR	7999-5-800A01
U106	IC, +5V, REGULATOR, 500MA	IC-93
U107	IC, UNDERVOLTAGE SENSE CIRCUIT	IC-1067
U108	IC, RS-232 LINE DRIVER/RECEIVER	IC-1129
VR101	DIODE, ZENER, 6.2V	DZ-97
Y101	CRYSTAL, 4MHZ	CR-36-4M

**Table 5-2**  
*Parts list—mechanical parts*

<b>Description</b>	<b>Keithley part number</b>
Bumper	FE-27A
Cover (bottom)	7999-4-301-2A
Cover (top)	7999-5-302A
Female screw-lock	CS-725
Lock-nut	4-40KEPNUT
Phillips Pan Head Screw	4-40X1/4PPH
Phillips Pan Head Screw	4-40X3/8PPH
Phillips Pan Head Screw SEMS (black)	4-40X3/8PPHSEMBLK

LTR.	ECA NO.	REVISION	ENG.	DATE
A	N/A	PRELIMINARY	MAH	7/8/99
B	23501	RELEASED	MAH	9/3/99
B1	24102	MC-612 WAS MC-285	CAD	2/11/00

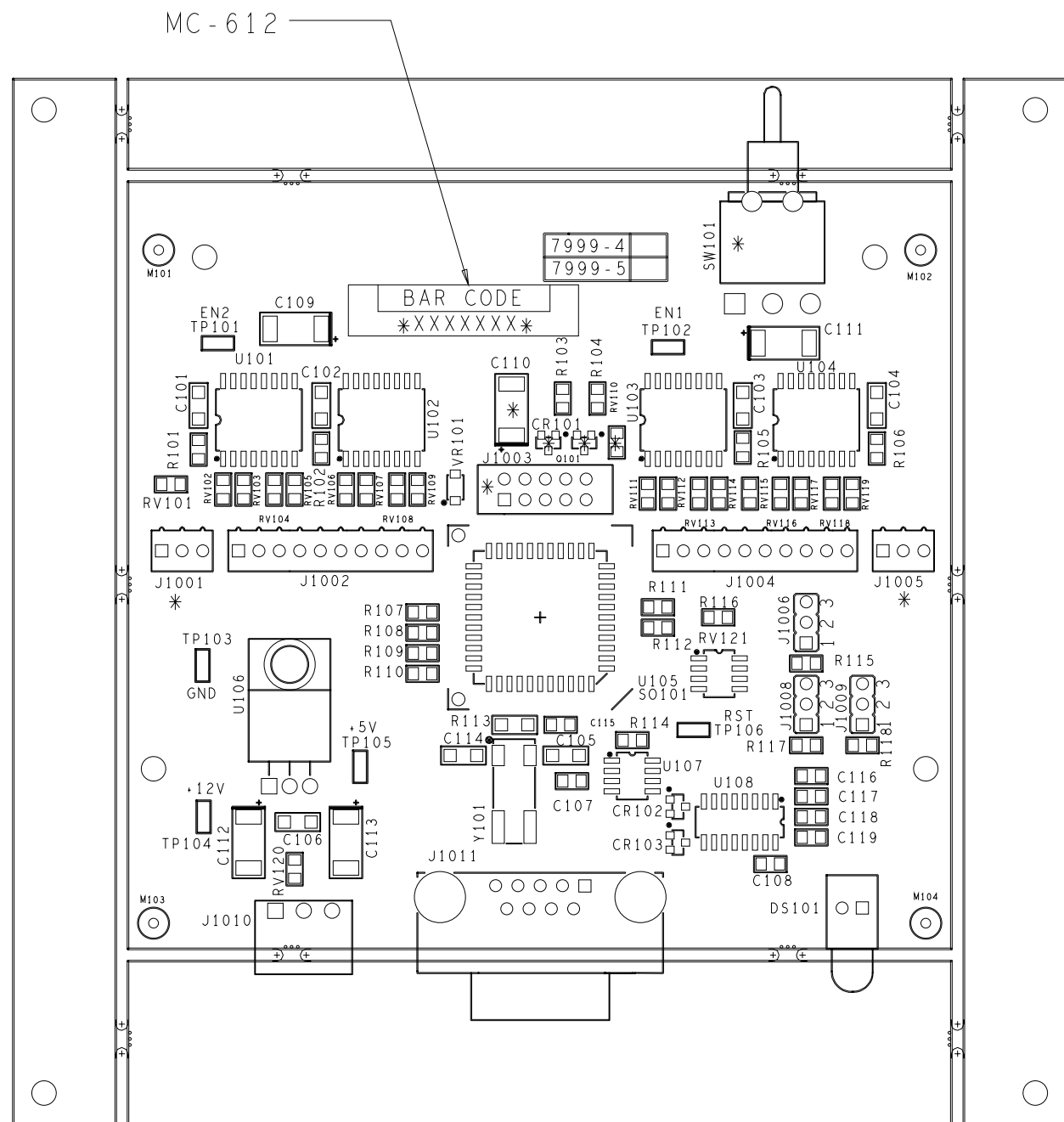

7999-4-102

FOR MODEL 7999-5

\*DO NOT POPULATE\*  
 PTH : J1001, J1003, J1005, SW101  
 SMT : C110, CR101, RV110, Q101

REFER TO THE 7999-5-102 PRODUCT STRUCTURE FOR FURTHER COMPONENT INFORMATION.

MODEL	NEXT ASSEMBLY	QTY.
USED ON		

<b>KEITHLEY</b> KEITHLEY INSTRUMENTS INC. CLEVELAND, OHIO 44139	DIM ARE IN IN. UNLESS OTHERWISE NOTED	DATE 7/12/99	SCALE 2:1	TITLE COMPONENT LAYOUT, 16 CHANNEL RELAY CONTROLLER
	DIM. TOL. UNLESS OTHERWISE SPECIFIED	DRN MAH	APPR. DL	
	XX: .01 XXX: .005	ANG.: .1 FRAC.: 1/64	DO NOT SCALE THIS DRAWING	



---

# Index

## C

- Card cleaning 4-2
- Carriage return 3-2
- Carriage return and line feed 3-2
- Command interpretation 3-5
- Component layout 5-2
- Configuration 2-3
- configure termination character 3-3
- connections 1-4
  - introduction 2-2
  - Quick disconnect connections 2-5
  - RS-232 2-4

## D

- Disassembly 4-3

## E

- Environmental conditions 4-4

## F

- Factory service 5-2
- Feature overview 1-2
- flux 4-3

## G

- general information 1-2

## H

- Handling 4-2
- Handling precautions 1-3, 2-2, 4-2

## I

- Inspection for damage 1-3
- Instruction manual 1-4

## J

- J1006 3-3
- J1008 3-3
- Jumper location 3-3

## L

- Layout 2-3
- Line feed 3-2
- Line feed and carriage return 3-2

## M

- Manual addenda 1-2
- Maximum voltage and current considerations 3-2

## O

- Operation
  - Introduction 3-2
  - RS-232 3-2
- Ordering information 5-2
- Output saturation voltage verification procedure 4-5
- overview 1-2

## P

- Parts list 5-2
- Performance verification 4-3, 4-4
- Power connector 2-5

## Q

- Quick disconnect connections 2-5

## R

- Recommended equipment 4-4
- Relay connector terminals 2-5, 2-6
- Repacking 1-4
- Repair Department Phone Number 5-2
- Replacement parts 4-3
- Replacement precautions 4-3
- Replacing components 4-3
- RS-232 Command set 3-4
- RS-232 connector terminals 2-4

## S

- Safety Precautions
- Safety symbols and terms 1-3
- Sending and receiving data 3-2
- Shipment contents 1-4
- Soldering considerations 4-3
- symbols and terms 1-3

## T

- Termination characters 3-2

## U

- Unpacking and inspection 1-3

## W

- Warranty 1-2

---

---

# Service Form

Model No. \_\_\_\_\_ Serial No. \_\_\_\_\_ Date \_\_\_\_\_

Name and Telephone No. \_\_\_\_\_

Company \_\_\_\_\_

List all control settings, describe problem and check boxes that apply to problem. \_\_\_\_\_

\_\_\_\_\_

Intermittent                       Analog output follows display                       Particular range or function bad; specify \_\_\_\_\_

IEEE failure                       Obvious problem on power-up                       Batteries and fuses are OK

Front panel operational     All ranges or functions are bad                       Checked all cables

Display or output (check one)

Drifts                       Unable to zero                       Unstable

Overload                       Will not read applied input

Calibration only                       Certificate of calibration required                       Data required

(attach any additional sheets as necessary)

Show a block diagram of your measurement including all instruments connected (whether power is turned on or not). Also, describe signal source.

Where is the measurement being performed? (factory, controlled laboratory, out-of-doors, etc.) \_\_\_\_\_

What power line voltage is used? \_\_\_\_\_ Ambient temperature? \_\_\_\_\_ °F

Relative humidity? \_\_\_\_\_ Other? \_\_\_\_\_

Any additional information. (If special modifications have been made by the user, please describe.)

\_\_\_\_\_

Be sure to include your name and phone number on this service form.







**Keithley Instruments, Inc.**

28775 Aurora Road

Cleveland, Ohio 44139

Printed in the U.S.A.