

DAS-Scan

**USER'S GUIDE**

# **DAS-Scan User's Guide**

Revision B - November 1996  
Part Number: 94880

## New Contact Information

Keithley Instruments, Inc.  
28775 Aurora Road  
Cleveland, OH 44139

Technical Support: 1-888-KEITHLEY  
Monday – Friday 8:00 a.m. to 5:00 p.m (EST)  
Fax: (440) 248-6168

Visit our website at <http://www.keithley.com>

The information contained in this manual is believed to be accurate and reliable. However, Keithley Instruments, Inc., assumes no responsibility for its use or for any infringements of patents or other rights of third parties that may result from its use. No license is granted by implication or otherwise under any patent rights of Keithley Instruments, Inc.

KEITHLEY INSTRUMENTS, INC., SHALL NOT BE LIABLE FOR ANY SPECIAL, INCIDENTAL, OR CONSEQUENTIAL DAMAGES RELATED TO THE USE OF THIS PRODUCT. THIS PRODUCT IS NOT DESIGNED WITH COMPONENTS OF A LEVEL OF RELIABILITY SUITABLE FOR USE IN LIFE SUPPORT OR CRITICAL APPLICATIONS.

Refer to your Keithley Instruments license agreement for specific warranty and liability information.

MetraByte and VTX are trademarks of Keithley Instruments, Inc. All other brand and product names are trademarks or registered trademarks of their respective companies.

© Copyright Keithley Instruments, Inc., 1996.

All rights reserved. Reproduction or adaptation of any part of this documentation beyond that permitted by Section 117 of the 1976 United States Copyright Act without permission of the Copyright owner is unlawful.

**Keithley MetraByte Division**

**Keithley Instruments, Inc.**

440 Myles Standish Blvd. Taunton, MA 02780

Telephone: (508) 880-3000 • FAX: (508) 880-0179

# Preface

The *DAS-Scan User's Guide* contains information and instructions for setting up and using a DAS-Scan data acquisition system.

The manual is intended for data acquisition system designers, engineers, technicians, scientists, and other users responsible for installing, starting up, and wiring signals to a DAS-Scan system. It is assumed that you are familiar with data acquisition principles, with your particular application, and with an IBM® PC AT® computer (or equivalent) in the Windows® environment. The computer must use an Intel 80386 or newer central processor.

The *DAS-Scan User's Guide* is organized as follows:

- Chapter 1 provides an overview of the hardware and describes features, applications, supporting software, and accessories.
- Chapter 2 describes how to unpack system components, install software, and configure system components.
- Chapter 3 describes how to assemble your system.
- Chapter 4 describes how to start up and use the DAS-Scan Control Panel to test your system.
- Chapter 5 describes how to isolate common problems, how to troubleshoot your system, and how to obtain technical support.
- Chapter 6 describes how to calibrate your system.
- Chapter 7 provides functional descriptions for both system and board levels.
- Appendix A contains specifications.
- Appendix B describes how to use the Keithley Memory Manager.

- Appendix C contains blank forms you can copy and use for making channel-routing maps.
- Appendix D contains information on CE certification.
- Appendix E contains information for enhancing the performance of your DAS-Scan system.

An index completes the manual.

# Table of Contents

## Preface

### 1 Overview

Features .....	1-1
Principal Parts .....	1-3
Supporting Software.....	1-5
Accessories.....	1-7

### 2 Setup

Unwrapping and Inspecting Your Equipment .....	2-2
Checking Your Bundle Contents .....	2-3
Installing the ASO-SCAN Software.....	2-4
Creating a Channel-Routing Map .....	2-6
Configuring the SCAN-AD-HR Interface Board.....	2-8
Selecting the Base I/O Address.....	2-8
Selecting an External Clock/Trigger/Gate .....	2-9
Selecting 12-Bit or 16-Bit Operation .....	2-10
Configuring the SCAN-BRD Assemblies .....	2-10
Setting the Assembly Address.....	2-12
Setting the Channel Input Jumpers .....	2-13
Creating/Modifying a Configuration File .....	2-16

### 3 System Assembly

Labelling Channel Routes .....	3-1
Mounting the SCAN-STP Screw Terminal Panels.....	3-2
Connecting Field Wiring .....	3-3
Nonisolated Voltage Measurements .....	3-5
Isolated Voltage Measurements.....	3-6
Current Measurements .....	3-7
Nonisolated Thermocouples Measurements .....	3-8
Isolated Thermocouples Measurements .....	3-9
Mounting a Chassis .....	3-10
Attaching the SCAN-CAB-64 Cables to the Chassis .....	3-12

	Setting Up and Testing Chassis Power . . . . .	3-19
	Setting Up an Internally Powered Chassis . . . . .	3-19
	Setting Up an Externally Powered Chassis . . . . .	3-20
	Checking Power Supply Operation . . . . .	3-22
	Installing and Removing a SCAN-BRD Assembly . . . . .	3-22
	Installing the SCAN-AD-HR Interface Board . . . . .	3-25
	Connecting the SCAN-AD-HR to the Chassis . . . . .	3-25
	Attaching SCAN-CAB-64 Cables to the SCAN-STPs . . . . .	3-27
	Connecting an External Clock/Trigger/Gate . . . . .	3-28
	Attaching Signal-Conditioning Backplanes . . . . .	3-28
<b>4</b>	<b>Testing the System</b>	
<b>5</b>	<b>Troubleshooting</b>	
	Checking the Computer . . . . .	5-1
	Checking the SCAN-AD-HR Interface Board . . . . .	5-2
	Checking the Accessory Slot and I/O Connections . . . . .	5-5
	Checking Chassis Power . . . . .	5-6
	Checking the SCAN-BRD Assemblies and Inputs . . . . .	5-6
	Technical Support . . . . .	5-7
<b>6</b>	<b>Calibration</b>	
	Equipment Requirements . . . . .	6-1
	Using the Calibration Utility . . . . .	6-2
	Calibrating the SCAN-AD-HR Interface Board . . . . .	6-3
	Calibrating a SCAN-BRD Assembly . . . . .	6-4
	Calibrating the CJC Sensor . . . . .	6-5
<b>7</b>	<b>Functional Descriptions</b>	
	DAS-Scan System . . . . .	7-1
	SCAN-STP Screw Terminal Panel . . . . .	7-3
	SCAN-BRD-TC/TC-ISO Assembly . . . . .	7-4
	Input-Conditioning Circuits . . . . .	7-6
	Multiplexer . . . . .	7-7
	Instrumentation Amplifier . . . . .	7-7
	Address Decoder . . . . .	7-8
	SCAN-BRD-V/V-ISO Assembly . . . . .	7-8
	Multiplexer . . . . .	7-9
	Instrumentation Amplifier . . . . .	7-9
	Address Decoder . . . . .	7-9



SCAN-AD-HR Interface Board . . . . .	7-9
Unipolar/Bipolar Selection . . . . .	7-11
Channel Sequencing and Gain Control . . . . .	7-11
Maximum Achievable Throughput Rates . . . . .	7-12
Conversion Modes . . . . .	7-13
Clock Sources . . . . .	7-14
Pacer Clock . . . . .	7-14
Burst Mode Conversion Clock . . . . .	7-15
Triggers . . . . .	7-15
Pre-Trigger Acquisition . . . . .	7-17
About-Trigger Acquisition . . . . .	7-18
Post-Trigger Acquisition . . . . .	7-18
Hardware Gate . . . . .	7-18
Data Transfer . . . . .	7-19

**A Specifications**

**B Keithley Memory Manager**

Installing and Setting Up the KMM in Windows 3.1 and Windows for Workgroups 3.11 . . . . .	B-2
Using KMMSETUP.EXE . . . . .	B-2
Using a Text Editor . . . . .	B-2
Installing and Setting Up the KMM in Windows 95 . . . . .	B-3
Removing the KMM . . . . .	B-4

**C Blank Channel Mapping Forms**

**D CE Information for the DAS-Scan System**

Limitation of Certification . . . . .	D-1
Declaration of Conformity . . . . .	D-2
Requirements for CE Configuration . . . . .	D-3

**E Maximizing System Performance**

Setting up a Scan of More than 256 Channels . . . . .	E-1
Improving Accuracy . . . . .	E-2
Reducing the Effects of Power-Line Noise . . . . .	E-4

**Index**

## List of Figures

Figure 1-1.	Principal Parts of the DAS-Scan System . . . . .	1-3
Figure 2-1.	Locations of Switch S1 and Jumpers J6 and J7 . . . . .	2-8
Figure 2-2.	Base I/O Address Switch . . . . .	2-9
Figure 2-3.	Jumper J6 . . . . .	2-9
Figure 2-4.	Jumper J7 . . . . .	2-10
Figure 2-5.	Configurable Components of SCAN-BRD Assembly . . . . .	2-11
Figure 2-6.	Thumbwheel Switches . . . . .	2-12
Figure 2-7.	SCAN-BRD-TC/TC-ISO Jumper Blocks . . . . .	2-13
Figure 2-8.	16-Position Jumper Block . . . . .	2-14
Figure 2-9.	16-Position and 14-Position Bank Jumpers . . . . .	2-15
Figure 2-10.	Enabling the CJC Input . . . . .	2-15
Figure 3-1.	Channel-Routing Labels . . . . .	3-2
Figure 3-2.	Installing Insertion Blocks . . . . .	3-4
Figure 3-3.	Installing Overlapping Insertion Blocks . . . . .	3-4
Figure 3-4.	Differential Voltage Inputs (Nonisolated) . . . . .	3-5
Figure 3-5.	Single-Ended Voltage Inputs (Nonisolated) . . . . .	3-6
Figure 3-6.	Differential Voltage Inputs (Isolated) . . . . .	3-6
Figure 3-7.	Single-Ended Voltage Inputs (Isolated) . . . . .	3-7
Figure 3-8.	Current Inputs . . . . .	3-7
Figure 3-9.	Floating Thermocouple Inputs (Nonisolated) . . . . .	3-8
Figure 3-10.	Grounded Thermocouple Inputs (Nonisolated) . . . . .	3-8
Figure 3-11.	Floating Thermocouple Inputs (Isolated) . . . . .	3-9
Figure 3-12.	Grounded Thermocouple Inputs (Isolated) . . . . .	3-9
Figure 3-13.	Full-Size Chassis in Mounting Rack . . . . .	3-10
Figure 3-14.	Half-Size Chassis in Mounting Rack . . . . .	3-11
Figure 3-15.	Mounting a Chassis on a Flat Surface (Side View) . . . . .	3-12
Figure 3-16.	Mounting Screws . . . . .	3-13
Figure 3-17.	Connector Frame . . . . .	3-14
Figure 3-18.	Rear View of Connector Frame (Half-Size Chassis) . . . . .	3-15
Figure 3-19.	Partial Rear View of Connector Frame (Full-Size Chassis) . . . . .	3-15
Figure 3-20.	SCAN-CAB-64 Cables on Hangers . . . . .	3-18
Figure 3-21.	Power Cord Receptacle (Internal Power) . . . . .	3-19
Figure 3-22.	Strain Relief . . . . .	3-20
Figure 3-23.	Voltage Connections for the SCAN-CH-HALF Power Cord Connector . . . . .	3-21
Figure 3-24.	Voltage Connections for the SCAN-CH-FULL Power Cord Connector . . . . .	3-21

Figure 3-25. Ejector Levers Positioned for Inserting a SCAN-BRD Assembly . . . . .	3-23
Figure 3-26. Ejector Lever Positioned for Removing a SCAN-BRD Assembly . . . . .	3-24
Figure 3-27. Connecting SCAN-AD-HR Board to Chassis . . .	3-26
Figure 3-28. Connecting Multiple Chassis . . . . .	3-26
Figure 3-29. Attaching SCAN-CAB-64 Cables to the SCAN-STPs . . . . .	3-27
Figure 3-30. Connecting an External Clock/Trigger/Gate Signal . . . . .	3-28
Figure 3-31. Connecting Signal-Conditioning Backplanes . . .	3-29
Figure 4-1. Locations of the Power-On and Board-Select LEDs . . . . .	4-3
Figure 7-1. Block Diagram of the DAS-Scan System . . . . .	7-2
Figure 7-2. CJC Circuitry . . . . .	7-4
Figure 7-3. Block Diagram of SCAN-BRD-TC/TC-ISO . . . . .	7-5
Figure 7-4. Input-Conditioning Circuitry . . . . .	7-6
Figure 7-5. Block Diagram of SCAN-BRD-V/V-ISO . . . . .	7-8
Figure 7-6. Block Diagram of SCAN-AD-HR Interface Board . . . . .	7-10
Figure 7-7. Conversion Modes . . . . .	7-13
Figure 7-8. Initiating Conversions with a Software Trigger .	7-16
Figure 7-9. Initiating Conversions with an External Digital Trigger . . . . .	7-17
Figure 7-10. Hardware Gate . . . . .	7-19
Figure D-1. CE Configuration for a DAS-Scan System . . . . .	D-3
Figure E-1. Improving Accuracy . . . . .	E-3

**List of Tables**

Table 2-1. Bundles . . . . .	2-3
Table 2-2. Channel-Routing Map . . . . .	2-7
Table 2-3. Channels Associated with Jumper Blocks . . . . .	2-14
Table 2-4. Default Configuration File Settings . . . . .	2-16
Table 2-5. Assembly Addresses . . . . .	2-18
Table 3-1. Connector Frame Position Numbers . . . . .	3-16
Table 5-1. Troubleshooting Information . . . . .	5-3
Table 7-1. Gains and Ranges for a DAS-Scan System . . . . .	7-3
Table A-1. Specifications for DAS-Scan System . . . . .	A-1

Table 2-1.	Bundles . . . . .	2-3
Table 2-2.	Channel-Routing Map . . . . .	2-7
Table 2-3.	Channels Associated with Jumper Blocks . . . . .	2-14
Table 2-4.	Default Configuration File Settings . . . . .	2-16
Table 2-5.	Assembly Addresses . . . . .	2-18
Table 3-1.	Connector Frame Position Numbers . . . . .	3-16
Table 5-1.	Troubleshooting Information . . . . .	5-3
Table 7-1.	Gains and Ranges for a DAS-Scan System . . . . .	7-3
Table A-1.	Specifications for DAS-Scan System . . . . .	A-1

Figure 1-1.	Principal Parts of the DAS-Scan System . . . . .	1-3
Figure 2-1.	Locations of Switch S1 and Jumpers J6 and J7 . . . . .	2-8
Figure 2-2.	Base I/O Address Switch . . . . .	2-9
Figure 2-3.	Jumper J6 . . . . .	2-9
Figure 2-4.	Jumper J7 . . . . .	2-10
Figure 2-5.	Configurable Components of SCAN-BRD Assembly	2-11
Figure 2-6.	Thumbwheel Switches . . . . .	2-12
Figure 2-7.	SCAN-BRD-TC/TC-ISO Jumper Blocks . . . . .	2-13
Figure 2-8.	16-Position Jumper Block . . . . .	2-14
Figure 2-9.	16-Position and 14-Position Bank Jumpers . . . . .	2-15
Figure 2-10.	Enabling the CJC Input . . . . .	2-15
Figure 3-1.	Channel-Routing Labels . . . . .	3-2
Figure 3-2.	Installing Insertion Blocks . . . . .	3-4
Figure 3-3.	Installing Overlapping Insertion Blocks . . . . .	3-4
Figure 3-4.	Differential Voltage Inputs (Nonisolated) . . . . .	3-5
Figure 3-5.	Single-Ended Voltage Inputs (Nonisolated) . . . . .	3-6
Figure 3-6.	Differential Voltage Inputs (Isolated) . . . . .	3-6
Figure 3-7.	Single-Ended Voltage Inputs (Isolated) . . . . .	3-7
Figure 3-8.	Current Inputs . . . . .	3-7
Figure 3-9.	Floating Thermocouple Inputs (Nonisolated) . . . . .	3-8
Figure 3-10.	Grounded Thermocouple Inputs (Nonisolated) . . . . .	3-8
Figure 3-11.	Floating Thermocouple Inputs (Isolated) . . . . .	3-9
Figure 3-12.	Grounded Thermocouple Inputs (Isolated) . . . . .	3-9
Figure 3-13.	Full-Size Chassis in Mounting Rack . . . . .	3-10
Figure 3-14.	Half-Size Chassis in Mounting Rack . . . . .	3-11
Figure 3-15.	Mounting a Chassis on a Flat Surface (Side View) . . . . .	3-12
Figure 3-16.	Mounting Screws . . . . .	3-13
Figure 3-17.	Connector Frame . . . . .	3-14
Figure 3-18.	Rear View of Connector Frame (Half-Size Chassis) . . . . .	3-15
Figure 3-19.	Partial Rear View of Connector Frame (Full-Size Chassis) . . . . .	3-15
Figure 3-20.	SCAN-CAB-64 Cables on Hangers . . . . .	3-18
Figure 3-21.	Power Cord Receptacle (Internal Power) . . . . .	3-19
Figure 3-22.	Strain Relief . . . . .	3-20
Figure 3-23.	Voltage Connections for the SCAN-CH-HALF Power Cord Connector	3-21
Figure 3-24.	Voltage Connections for the SCAN-CH-FULL Power Cord Connector	3-21

Figure 3-25. Ejector Levers Positioned for Inserting a SCAN-BRD Assembly	3-23
Figure 3-26. Ejector Lever Positioned for Removing a SCAN-BRD Assembly	3-24
Figure 3-27. Connecting SCAN-AD-HR Board to Chassis . . .	3-26
Figure 3-28. Connecting Multiple Chassis . . . . .	3-26
Figure 3-29. Attaching SCAN-CAB-64 Cables to the SCAN-STPs	3-27
Figure 3-30. Connecting an External Clock/Trigger/Gate Signal .	3-28
Figure 3-31. Connecting Signal-Conditioning Backplanes . . .	3-29
Figure 4-1. Locations of the Power-On and Board-Select LEDs.	4-3
Figure 7-1. Block Diagram of the DAS-Scan System . . . . .	7-2
Figure 7-2. CJC Circuitry . . . . .	7-4
Figure 7-3. Block Diagram of SCAN-BRD-TC/TC-ISO . . . . .	7-5
Figure 7-4. Input-Conditioning Circuitry . . . . .	7-6
Figure 7-5. Block Diagram of SCAN-BRD-V/V-ISO . . . . .	7-8
Figure 7-6. Block Diagram of SCAN-AD-HR Interface Board . .	7-10
Figure 7-7. Conversion Modes . . . . .	7-13
Figure 7-8. Initiating Conversions with a Software Trigger .	7-16
Figure 7-9. Initiating Conversions with an External Digital Trigger	7-17
Figure 7-10. Hardware Gate . . . . .	7-19
Figure D-1. CE Configuration for a DAS-Scan System	D-3
Figure E-1. Improving Accuracy	E-3

# 1

## Overview

This chapter describes the following:

- Features of a DAS-Scan system
- Principal parts of a DAS-Scan system
- Supporting software
- Accessories

### Features

---

The DAS-Scan system is a measuring system capable of multiplexing up to 4,096 separate inputs for delivery to a single-channel interface board (SCAN-AD-HR) that performs A/D (analog-to-digital) conversions. The system measures the outputs of voltage, current, and/or thermocouple sensors fed to inputs that can be isolated or nonisolated. Input from voltage sensors can be differential or single-ended; inputs from current output devices can be from 0 to 20 mA; input from thermocouple sensors can be floating or grounded.

The SCAN-AD-HR interface board is designed for installation in an ISA (industry standard architecture) accessory slot of the computer. Other principal parts of the DAS-Scan system include the SCAN-BRD multiplexer assemblies, the SCAN-CH chassis that contain the multiplexer assemblies, the SCAN-STP screw terminal panels, and the cables that connect the principal parts.

The SCAN-BRD assemblies are housed in rack-mountable SCAN-CH chassis that provide power and shielding. The SCAN-STP screw terminal panels are the interfaces for field wiring from the voltage, current, and thermocouple sensors and are mountable on DIN rails for convenient access (DIN is *Deutsch Industrie Norm*, a German standards organization).

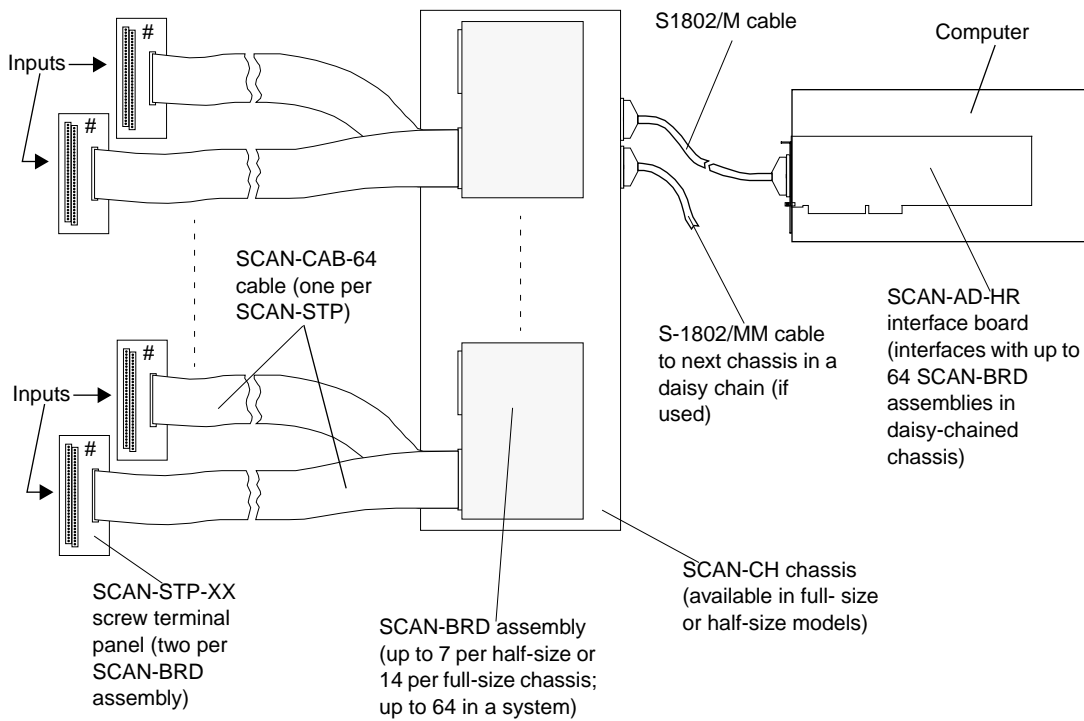
Additional features of a DAS-Scan system include the following:

- A 256-position channel-gain queue allows you to program the multiplexing order and gain of each channel.
- The chassis is an industry-standard Eurocard cage with EMC (electromagnetic compatibility) shielding.
- The DAS-Scan system fully meets CE certification requirements.
- Chassis design allows SCAN-BRD assemblies to be inserted or removed without disturbing field wiring.
- Multiple chassis systems can be daisy chained together.
- Gains of 1, 2, 4, 8, 50, 100, 200, and 400 are software-selectable with a maximum input range of 0 to 10 V in unipolar mode or  $\pm 10$  V in bipolar mode.
- The ASO-SCAN software package includes the following:
  - Support for programming in Windows languages such as C/C++ and Visual Basic.
  - Utilities for configuring, calibrating, and testing your system.
  - Example programs that show how to accommodate medium-channel and large-channel applications and how to linearize thermocouple measurements.
  - Support for using the ASO-SCAN software package to write 32-bit programs in the Windows 95 environment.
- The power supply in an internally powered chassis is self-sensing for voltages in the range of 90 to 264 VAC.



# Principal Parts

Figure 1-1 shows the principal parts of the DAS-Scan system.



**Figure 1-1. Principal Parts of the DAS-Scan System**

The principal parts of a DAS-Scan system are described as follows:

- **SCAN-STP screw terminal panels** - Accept 32 pairs of wires from voltage, current, or thermocouple sensors. The following models of SCAN-STPs are available:
  - SCAN-STP-V - Accepts wiring from voltage sensors.
  - SCAN-STP-I - Accepts wiring from current sensors; provides current-to-voltage conversion.
  - SCAN-STP-TC - Accepts wiring from thermocouples; contains a sensor for cold junction compensation (CJC).
- **SCAN-BRD assemblies** - Dual-board assemblies that accept up to 64 inputs from two SCAN-STP screw terminal panels and multiplex the inputs into a single channel for delivery to the SCAN-AD-HR interface board. The following models of SCAN-BRD assemblies are available:
  - SCAN-BRD-TC-ISO - Isolated assembly for measuring voltage, current, or thermocouple inputs.
  - SCAN-BRD-TC- Nonisolated assembly for measuring voltage, current, or thermocouple inputs; provides higher multiplexing speeds.
  - SCAN-BRD-V-ISO - Isolated assembly for measuring voltage or current inputs.
  - SCAN-BRD-V - Nonisolated assembly for measuring voltage or current inputs; provides higher multiplexing speed.
- **SCAN-CAB-64 cable** - A 100-inch (2.5 m) cable that connects a SCAN-STP screw terminal panel to a SCAN-BRD assembly.
- **SCAN-CH chassis** - Shields and powers the SCAN-BRD assemblies. The following models of SCAN-CH chassis are available:
  - SCAN-CH-FULL - Full-size chassis (holds 14 SCAN-BRD assemblies) with internal DC power supply; fits standard 19-inch rack.
  - SCAN-CH-HALF - Half-size chassis (holds seven SCAN-BRD assemblies) with internal DC supply; can be used with the SCAN-ADAPTER-HALF accessory kit to fit standard 19-inch rack.

- SCAN-CH-FULL/NO PWR - Version of SCAN-CH-FULL without internal power supply.
- SCAN-CH-HALF/NO PWR- Version of SCAN-CH-HALF without internal power supply.
- **PWRCORD power cord** - For chassis with internal power supplies. The following models are available:
  - PWRCORD/NA - For use in North America.
  - PWRCORD/EUR- For use in continental Europe (except the United Kingdom).
  - PWRCORD/UK - For use in the United Kingdom.
- **S-1802/M cable** - A 3.5-foot (1.1 m) shielded cable that connects the first chassis in your DAS-Scan system to the SCAN-AD-HR interface board.
- **S-1802/MM cable** - A 3.5-foot (1.1 m) shielded cable that connects additional SCAN-CH chassis in a multiple-chassis system.
- **SCAN-AD-HR interface board** - Fits an ISA accessory slot in an IBM PC AT (or equivalent) computer. The SCAN-AD-HR contains the A/D conversion circuitry.

## Supporting Software

---

The following software is available for operating a DAS-Scan system:

- **ASO-SCAN software package** - The software shipped with a DAS-Scan system. This package allows you to write programs in the Windows 3.1, Windows for Workgroups 3.11, or Windows 95 environment using Microsoft® Visual C++™, Borland® C/C++ for Windows, or Microsoft Visual Basic® for Windows. Refer to the *DAS-Scan Function Call Driver User's Guide* and to the online help for the DAS-Scan Function Call Driver for more information.

The following utility programs are provided with the ASO-SCAN software package:

- *DAS-Scan Control Panel* - The control panel (CTLSCAN.EXE) runs under Windows and allows you to perform simple analog input operations on one SCAN-BRD assembly at a time without programming. This utility provides a quick way to test your DAS-Scan system. Refer to Chapter 4 and to the control panel online help for more information.
- *DAS-Scan Configuration Utility* - The configuration utility (CFGSCAN.EXE) allows you to create a configuration file for use with the DAS-Scan Function Call Driver and other software. Refer to page 2-16 and to the configuration utility online help for more information.
- *Keithley Memory Manager* - The Keithley Memory Manager (KMM) allows you to reserve memory for your data collection program. Refer to Appendix B for more information.
- **VTX™ (Visual Test Extensions™)** - This optional software package enables you to create data acquisition programs using an integrated set of custom controls within the Visual Basic for Windows environment. Refer to the Keithley MetraByte product catalog for more information.
- **TestPoint™** - This optional software package allows you to create data acquisition programs in the Windows 3.1, Windows for Workgroups 3.11, Windows 95, or Windows NT 3.51 environment using a set of professional software tools instead of programming. Refer to the Keithley MetraByte catalog or contact your local sales office for more information.
- **DriverLINUX®NT** - This optional, high-performance driver allows you to create custom data acquisition programs in the Windows NT environment. Refer to the Keithley MetraByte catalog or contact your local sales office for more information.

## Accessories

---

The following accessories are available for your DAS-Scan system:

- **SCAN-ADAPTER-HALF kit** - Allows you to adapt a half-size chassis to fit a standard 19-inch mounting rack; includes an adapter panel and screws.
- **DIN rail** - Allows you to mount your SCAN-STP screw terminal panels in locations with convenient access to field wiring.
- **SCAN-MOUNT-PAIR** - A pair of angle brackets for attaching a full-size or half-size chassis to a horizontal surface.
- **CAB-SMA-BNC cable** - A 3-foot clock/trigger/gate input cable with a female SMA connector to female BNC connector. This cable connects to connector J5 on the SCAN-AD-HR interface board.
- **SCAN-SE-INSERT** - A package of twelve 6-position insertion blocks for shorting up to six alternate screw terminals of a SCAN-STP screw terminal panel. These blocks simplify the conversion of differential inputs to single-ended inputs at the screw terminals of the SCAN-STPs.
- **MB01 backplane** - A 16-channel backplane; plug-in MB Series modules provide isolation and signal-conditioning. Refer to the *MB Series User's Guide* for more information.
- **7BP16 backplane** - A 16-channel backplane; plug-in 7B Series modules provide isolation and signal-conditioning. The 7BP16 backplane is available from Analog Devices, Inc. (800 426-2564).
- **SCAN-ADAPTER-MB adapter** - Used to connect an MB01 or 7BP16 backplane to a SCAN-BRD assembly (two adapters per SCAN-BRD assembly; two backplanes per adapter).
- **AC1393 cable** - A 6-inch adapter cable that connects a 7BP16 backplane to a SCAN-ADAPTER-MB. The AC1393 cable is available from Analog Devices, Inc. (800 426-2564).
- **C-2600 cable** - An 18-inch ribbon cable with a 26-pin female header connector at each end; allows you to connect a SCAN-ADAPTER-MB adapter to an MB01 or 7BP16 backplane.

# 2

## Setup

This chapter describes the following:

- How to unwrap and inspect your equipment
- How to check the contents of your equipment bundles
- How to install the ASO-SCAN software
- How to create a channel-routing map
- How to configure the SCAN-AD-HR interface board
- How to configure a SCAN-BRD assembly
- How to create or modify a configuration file

## Unwrapping and Inspecting Your Equipment

---

To prevent any damage to your DAS-Scan system, perform the following steps when unpacking the equipment:

1. Remove the wrapped DAS-Scan equipment from its outer shipping carton.
2. Before you remove the SCAN-AD-HR interface board, SCAN-BRD assemblies, and SCAN-STP screw terminal panels from their anti-static wrappers, discharge any static electricity from yourself and the packages as follows:
  - If you are not wearing a grounded wrist strap, hold the wrapped equipment in one hand while placing your other hand firmly on a metal portion of the computer chassis. (Your computer must be turned OFF but grounded.)
  - If you are wearing a grounded wrist strap, static electricity is discharged as soon as you hold the equipment.
3. Carefully remove the anti-static wrappers. (You may wish to store the wrapping material for future use.)
4. Inspect all pieces from the package for signs of damage. If damage is apparent, arrange to return the damaged pieces to the factory; refer to page 5-7.
5. Check the contents of your package against the packing list to be sure your order is complete. Report any missing items immediately.
6. Check the contents of any equipment bundles against the bundle lists in the next section. Report any missing items immediately.
7. When you are satisfied with the inspection, proceed with the software and hardware setup instructions provided later in this chapter.

---

**Note:** DAS-Scan equipment is factory calibrated and requires no further adjustment prior to installation. If you decide to recalibrate at a later time, refer to Chapter 6 for instructions.

---

## Checking Your Bundle Contents

---

During your selection and purchase of DAS-Scan equipment, you considered equipment packages called "bundle" options. Table 2-1 lists the equipment part numbers and quantities packaged in each of the available DAS-Scan bundles. Check the bundles you ordered and make sure that you received the correct equipment.

**Table 2-1. Bundles**

<b>Bundle</b>	<b>Part Number</b>	<b>Description</b>	<b>Number</b>
SCAN-SYS-FULL	SCAN-CH-FULL	Full chassis with power supply	1
	SCAN-AD-HR	Interface board	1
	S-1802/M	SCAN-AD-HR to SCAN-CH chassis cable	1
SCAN-SYS-HALF	SCAN-CH-HALF	Half chassis with power supply	1
	SCAN-AD-HR	Interface board	1
	S-1802/M	SCAN-AD-HR to SCAN-CH chassis cable	1
SCAN-SYS-TC-ISO	SCAN-BRD-TC-ISO	Isolated thermocouple assembly	1
	SCAN-STP-TC	Screw terminal panel	2
	SCAN-CAB-64	SCAN-STP-TC to SCAN-BRD assembly cable	2
SCAN-SYS-TC	SCAN-BRD-TC	Nonisolated thermocouple assembly	1
	SCAN-STP-TC	Screw terminal panel	2
	SCAN-CAB-64	SCAN-STP-TC to SCAN-BRD assembly cable	2



**Table 2-1. Bundles (cont.)**

<b>Bundle</b>	<b>Part Number</b>	<b>Description</b>	<b>Number</b>
SCAN-SYS-V-ISO	SCAN-BRD-V-ISO	Isolated voltage assembly	1
	SCAN-STP-V	Screw terminal panel	2
	SCAN-CAB-64	SCAN-STP-V to SCAN-BRD assembly cable	2
SCAN-SYS-V	SCAN-BRD-V	Nonisolated voltage assembly	1
	SCAN-STP-V	Screw terminal panel	2
	SCAN-CAB-64	SCAN-STP-V to SCAN-BRD assembly cable	2
SCAN-SYS-I-ISO	SCAN-BRD-V-ISO	Isolated voltage assembly	1
	SCAN-STP-I	Screw terminal panel	2
	SCAN-CAB-64	SCAN-STP-I to SCAN-BRD assembly cable	2
SCAN-SYS-I	SCAN-BRD-V	Nonisolated voltage assembly	1
	SCAN-STP-I	Screw terminal panel	2
	SCAN-CAB-64	SCAN-STP-I to SCAN-BRD assembly cable	2

## **Installing the ASO-SCAN Software**

---

To install the ASO-SCAN software package, perform the following steps:

1. Make copies of the supplied disks. Use the copies as your working disks and store the originals as backups.
2. Insert disk 1 into an appropriate disk drive.
3. Start Windows, if necessary.
4. *If you are using Windows 3.1 or Windows for Workgroups 3.11:*
  - Click **Run** on the **File** menu of the Program Manager.*If you are using Windows 95:*
  - Click **Run** on the **Start** menu.

5. In the Run dialog box, enter the appropriate drive letter and the setup command. For example, if the disk is in drive A, enter

```
a:\setup
```

and then click **OK**.

The installation program prompts you for your installation preferences, including which languages you will be using and the drive and directory you want to copy the software to. It also prompts you to insert additional disks, as necessary.

6. Continue to insert disks and respond to prompts, as appropriate.

When the installation program prompts you for a drive designation, enter a designation of your choosing or accept the default drive C. When the installation program prompts you for a directory name, enter a name of your choosing or accept the default name.

The installation program creates a directory on the specified drive and copies all files, expanding any compressed files.

The installation program also creates a DAS-Scan program group; this program group includes icons for the Keithley MetraByte utilities, example programs, and help files.

7. *If you are using Windows 95 to write 32-bit programs*, install the ASO-Win95/32-Bit software, as follows:

- Insert the ASO-Win95/32-Bit disk into the appropriate disk drive.
- Click **Run** on the **Start** menu.
- In the Run dialog box, enter the appropriate drive letter and the setup command. For example, if the disk is in drive A, enter

```
a:\setup
```

and then click **OK**.

- Respond to the prompts, as appropriate. To avoid overwriting files with the same name, install the ASO-Win95/32-Bit software in a different directory from the one in which you installed the ASO-SCAN software package.

8. When the installation program notifies you that the installation is complete, review the following files:
  - FILES.TXT lists and describes all the files copied to the hard disk by the installation program.
  - README.TXT contains information that was not available when this manual was printed. (Note that there are two README.TXT files: one in the ASO-SCAN installation directory and another in the ASO-Win95/32-Bit installation directory.)

## Creating a Channel-Routing Map

---

Before you can assemble your DAS-Scan system, you must plan and map the routing of the input channels through the SCAN-STP screw terminal panels, the SCAN-CAB-64 cables, and the SCAN-BRD assemblies. The system assembly process can then follow your map. In your planning process, it is recommended that you keep SCAN-BRD assemblies of the same type together as much as possible. Table 2-2 is an example of a channel-routing map for a SCAN-BRD assembly in slot 5 with two SCAN-STP screw terminal panels. Blank mapping forms are available for copying in Appendix C.

---

**Note:** Software for your DAS-Scan system requires that you always connect SCAN-STP #0 to the base board of a SCAN-BRD assembly and that you always connect SCAN-STP #1 to the mezzanine board. Please create your channel-routing map accordingly.

---

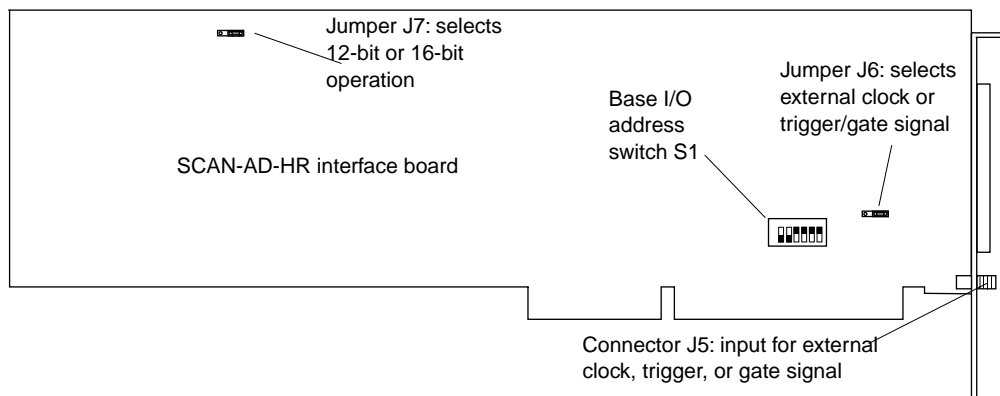
**Table 2-2. Channel-Routing Map**

Chassis # (User's Choice)	Chassis Slot # (1 to 7 or 1 to 14)	SCAN-BRD Address (00h to 3Fh)	SCAN-BRD Chan. # (0 to 63)	SCAN-STP # (0 or 1)	SCAN-STP Screw Terminal (0 to 31)	System Chan. # (0 to 4095)	Channel Tag (User's Choice)
1	5	04	0 (Base brd.)	0	0	0	1st sensor
"	"	"	1 (Base brd.)	0	1	1	2nd sensor
"	"	"	2 (Base brd.)	0	2	2	3rd sensor
"	"	"	3 (Base brd.)	0	3	3	4th sensor
"	"	"	4 (Base brd.)	0	4	4	5th sensor
"	"	"	5 (Base brd.)	0	5	5	6th sensor
"	"	"	6 (Base brd.)	0	6	6	7th sensor
"	"	"	7 (Base brd.)	0	7	7	8th sensor
• • •							
"	"	"	29 (Base brd.)	0	29	29	30th sensor
"	"	"	30 (Base brd.)	0	30	30	31st sensor
"	"	"	31 (Base brd.)	0	31	31	32nd sensor
1	5	04	32 (Mezz. brd.)	1	0	32	33rd sensor
"	"	"	33 (Mezz. brd.)	1	1	33	34th sensor
"	"	"	34 (Mezz. brd.)	1	2	34	35th sensor
"	"	"	35 (Mezz. brd.)	1	3	35	36th sensor
"	"	"	36 (Mezz. brd.)	1	4	36	37th sensor
"	"	"	37 (Mezz. brd.)	1	5	37	38th sensor
"	"	"	38 (Mezz. brd.)	1	6	38	39th sensor
"	"	"	39 (Mezz. brd.)	1	7	39	40th sensor
• • •							
"	"	"	60 (Mezz. brd.)	1	28	60	61st sensor
"	"	"	61 (Mezz. brd.)	1	29	61	62nd sensor
"	"	"	62 (Mezz. brd.)	1	30	62	63rd sensor
"	"	"	63 (Mezz. brd.)	1	31	63	64th sensor

## Configuring the SCAN-AD-HR Interface Board

---

Configurable hardware on the SCAN-AD-HR interface board includes a base I/O address switch, a 2-position jumper (J6) for selecting an external clock/trigger/gate, and a 2-position jumper (J7) for selecting 12-bit or 16-bit operation, as shown in Figure 2-1.

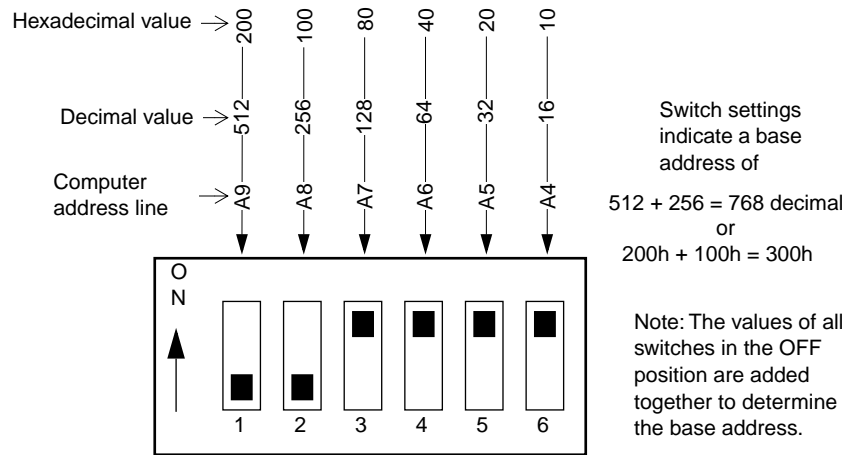


**Figure 2-1. Locations of Switch S1 and Jumpers J6 and J7**

The following subsections describe how to select the base I/O address, an external clock/trigger/gate, and 12-bit or 16-bit operation.

### Selecting the Base I/O Address

The SCAN-AD-HR interface board requires 16 consecutive 8-bit locations in the I/O space of your computer starting at the base address. The SCAN-AD-HR is shipped with a base address of 300h. If any of the required address locations starting at base address 300h are being used by another resource in your system, you must reconfigure the base address using the base I/O address switch. The base I/O address switch is a 6-position DIP switch, shown in Figure 2-2. Use the information in Figure 2-2 to determine the setting for a new base address.

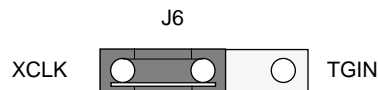


**Figure 2-2. Base I/O Address Switch**

Note that the least-significant address line in Figure 2-2 is A4. This line has a decimal value of 16; therefore, the address you select must have a 16-byte boundary.

## Selecting an External Clock/Trigger/Gate

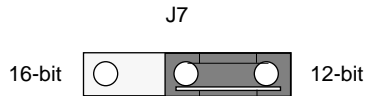
When using an external clock signal on coaxial connector J5, set jumper J6 for XCLK. When using an external trigger or gate on coaxial connector J5, set jumper J6 for TGIN. When using the internal clock or trigger/gate source, the position of J6 does not matter. The locations of connector J5 and jumper J6 are shown in Figure 2-1 on page 2-8. Jumper J6 is shown in Figure 2-3.



**Figure 2-3. Jumper J6**

## Selecting 12-Bit or 16-Bit Operation

Set jumper J7 in the 16-bit position for calibration only. Set jumper J7 in the 12-bit position (the factory-default position) for all other operations. Jumper J7 is shown in Figure 2-4.

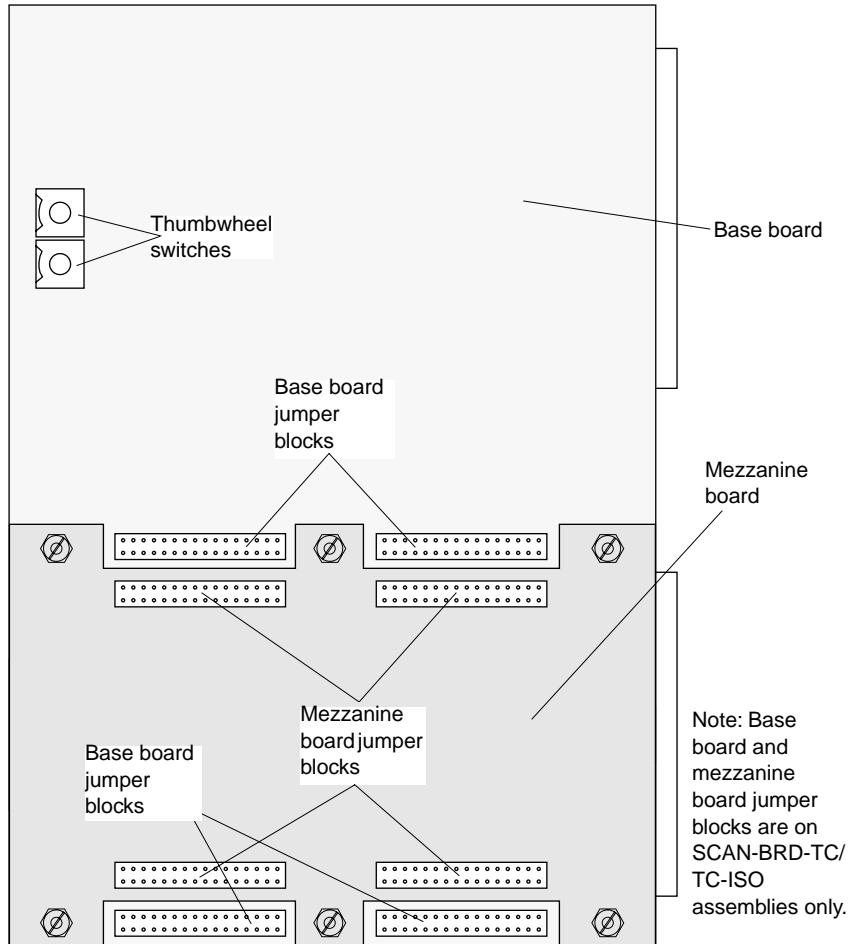


**Figure 2-4. Jumper J7**

## Configuring the SCAN-BRD Assemblies

---

A SCAN-BRD assembly consists of a base board and an attached mezzanine board. All SCAN-BRD assemblies contain two thumbwheel switches for setting the assembly address. The SCAN-BRD-TC/TC-ISO assemblies also contain jumper blocks for configuring channel input circuits. These components are shown in Figure 2-5.



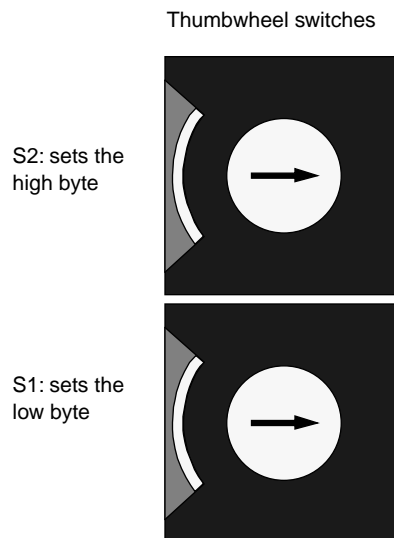
**Figure 2-5. Configurable Components of SCAN-BRD Assembly**

The following sections describe how to configure SCAN-BRD assemblies.



## Setting the Assembly Address

Before you set the assembly address on a SCAN-BRD assembly, refer to the channel-routing map that you created. The assembly address is a 2-digit, hexadecimal number ranging from 00h to 3Fh (0 to 63 decimal, because the DAS-Scan system can accommodate up to 64 SCAN-BRD assemblies). Set the assembly address using the two thumbwheel switches shown in Figure 2-6.



**Figure 2-6. Thumbwheel Switches**

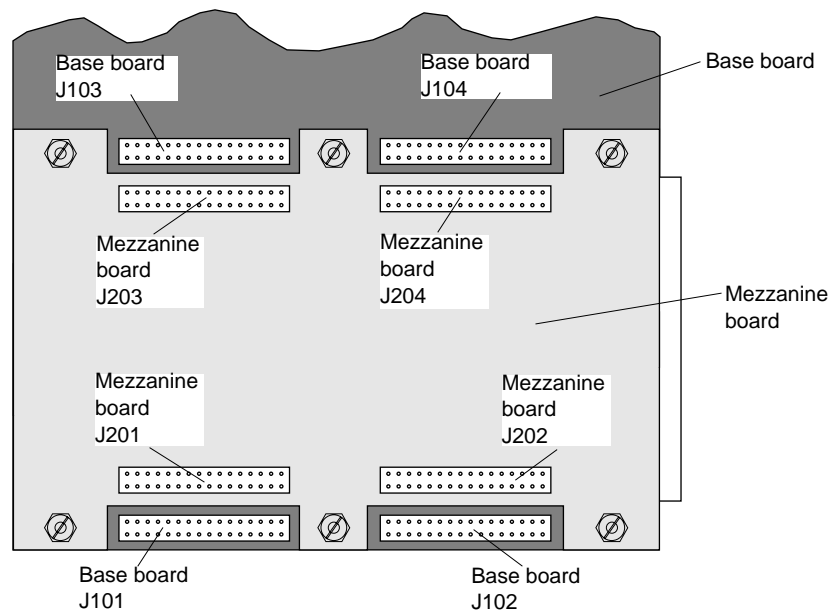
The range of each switch is 0h to Fh. The high-byte setting is the left digit of the address; the low-byte setting is the right digit.

Use your fingers or a small screwdriver to make the thumbwheel settings from the side or from the top. Positions of the switches are marked on the side of the thumbwheel and also on the top of the switch.

## Setting the Channel Input Jumpers

On a SCAN-BRD-TC/TC-ISO assembly only, jumper blocks allow you to connect input-conditioning circuits to the input channels; separate input-conditioning circuits are available for each input. (Refer to page 7-6 for detailed information about the input-conditioning circuits.)

Figure 2-7 shows the jumper blocks on a SCAN-BRD-TC/TC-ISO assembly.



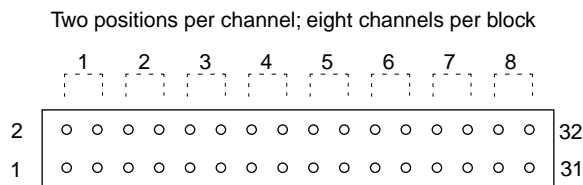
**Figure 2-7. SCAN-BRD-TC/TC-ISO Jumper Blocks**

The channel numbers associated with each jumper block on the base board and on the mezzanine board are listed in Table 2-3.

**Table 2-3. Channels Associated with Jumper Blocks**

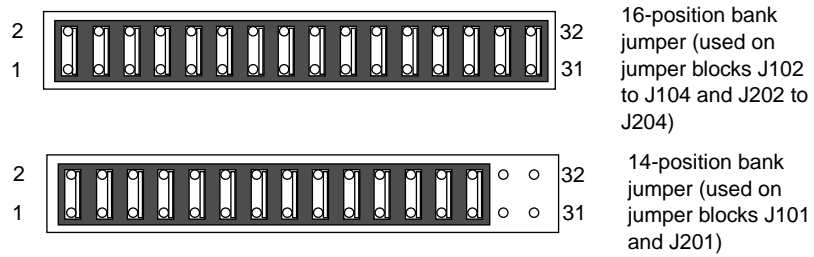
Board	Jumper Block	Channels
Base board	J104	0 to 7
	J103	8 to 15
	J102	16 to 23
	J101	24 to 31
Mezzanine board	J204	32 to 39
	J203	40 to 47
	J202	48 to 55
	J201	56 to 63

To connect input-conditioning circuits on a SCAN-BRD-TC/TC-ISO assembly, you need two types of bank (multiposition) jumpers: 14-position and 16-position. Each jumper block contains two positions per channel, as shown in Figure 2-8.



**Figure 2-8. 16-Position Jumper Block**

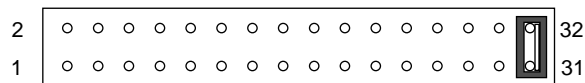
Jumper blocks J102 to J104 and J202 to J204 require 16-position bank jumpers; jumper blocks J101 and J201 require 14-position bank jumpers. The required bank jumpers are installed on the SCAN-BRD-TC/TC-ISO assembly at the factory. Figure 2-9 shows both types of bank jumpers.



**Figure 2-9. 16-Position and 14-Position Bank Jumpers**

When a bank jumper is installed, the jumpered channels are set for open thermocouple detection and their low sides are returned to ground. When no bank jumper is installed, the jumpered channels are floating.

A SCAN-BRD-TC/TC-ISO assembly also requires a standard, single-position jumper to enable or disable the CJC input (from the SCAN-STP-TC screw terminal panel). To enable the CJC input, place the jumper across pins 31 and 32 (the factory-default position). To disable the CJC input, remove the jumper from pins 31 to 32. (You can store the jumper on pins 29 to 30; these pins are not connected to any circuitry.) Figure 2-10 shows a single-position jumper set to enable the CJC input.



**Figure 2-10. Enabling the CJC Input**

## Creating/Modifying a Configuration File

---

Some software, such as the DAS-Scan Function Call Driver, VTX, and the DAS-Scan Control Panel, requires a configuration file. A default configuration file (DASSCAN.CFG) is provided in the ASO-SCAN software package. DASSCAN.CFG contains a set of default configuration options that take effect whenever you install or power-up the DAS-SCAN system.

DASSCAN.CFG treats each group of four SCAN-BRD assemblies as a virtual board. Each virtual board contains 256 logical channels (four SCAN-BRD assemblies multiplied by 64 physical channels on each).

These default configuration options are listed in Table 2-4.

**Table 2-4. Default Configuration File Settings**

Options	Default Settings
Base Address	300h
IRQ Level	10
DMA Channel	5
A/D Mode	Bipolar
Virtual Board 0	Assembly addresses: 0, 1, 2, and 3
Virtual Board 1	Assembly addresses: 4, 5, 6, and 7

If you are using two virtual boards and the default options are appropriate for your application, you can skip the rest of this section. If the default options are not appropriate for your application, you must specify the appropriate options in a configuration file, using the CFGSCAN.EXE configuration utility.

To create a new configuration file or modify an existing configuration file, perform the following steps:

1. Double-click the configuration utility icon in the DAS-Scan program group.

The configuration utility displays the DAS-Scan CFG Panel with the default configuration file name (DASSCAN.CFG) and the default configuration options shown.

2. To modify an existing configuration file, click **Open** in the **File** menu, select the appropriate configuration file, and then go to step 3.

To create a new configuration file, go directly to step 3.

3. Modify the system-level configuration options; these settings apply to all the virtual boards in the DAS-Scan system. The system-level configuration options are described as follows:

- *Base Address* - The base address setting on the SCAN-AD-HR interface board. Select a base address from 200h to 400h.

Note that the address you select must match the setting of the base I/O address switch on the board. Refer to page 2-8 for information on setting the base I/O address switch.

- *IRQ Level* - The interrupt request level used by the computer. Select an interrupt level of 3, 5, 7, 10, 11, or 15.
- *DMA Channel* - The DMA (Direct Memory Access) channel or channel-pair used for the transfer of data to computer memory. Select 5, 6, 7, 5+6, 6+7, or 7+5.

4. Modify the configuration options for each virtual board. Use the up or down arrow to select the appropriate virtual board.

Each virtual board represents up to four SCAN-BRD assemblies. Since each SCAN-BRD assembly contains 64 physical channels, each virtual board represents up to 256 logical channels. You can configure up to 16 virtual boards, numbered from 0 to 15, for a maximum of 4,096 logical channels (16 virtual boards  $\times$  256 logical channels = 4,096 logical channels).

The configuration options for each virtual board are described as follows:

- *A/D Mode* - The input range type. Select bipolar or unipolar for each virtual board.
- *Addresses* - The four assembly addresses for the four SCAN-BRD assemblies (SCAN-BRD0 to SCAN-BRD3) associated with each virtual board.

The address you select for each SCAN-BRD assembly must match the assembly address set by the thumbwheels on that SCAN-BRD assembly. Refer to page 2-12 for information on setting the assembly address thumbwheel.

If you do not use four SCAN-BRD assemblies for a particular virtual board, set the assembly addresses of any unused SCAN-BRD assemblies to X.

To simplify your record keeping, it is recommended that you assign the SCAN-BRD assemblies sequential addresses. However, you can assign any address to any SCAN-BRD assembly, as long as no two SCAN-BRD assemblies have the same address.

Table 2-5 shows a sequential assignment of assembly addresses for a full complement of full-size chassis.

**Table 2-5. Assembly Addresses**

<b>Chassis</b>	<b>Virtual Board</b>	<b>Chassis Slot</b>	<b>Assembly Address</b>
1	0	1	0h
		2	1h
		3	2h
		4	3h
	1	5	4h
		6	5h
		7	6h
		8	7h

**Table 2-5. Assembly Addresses (cont.)**

<b>Chassis</b>	<b>Virtual Board</b>	<b>Chassis Slot</b>	<b>Assembly Address</b>	
1 (cont.)	2	9	8h	
		10	9h	
		11	Ah	
		12	Bh	
	3	13	Ch	
		14	Dh	
2	3	1	Eh	
		2	Fh	
	4	3	10h	
		4	11h	
		5	12h	
		6	13h	
			:	
			:	
5	14 (cont.)	1	3Ah	
		2	3Bh	
	15	3	3Ch	
		4	3Dh	
		5	3Eh	
		6	3Fh	

For more information about the configuration options, refer to the online help.



5. After you modify the configuration options, save the new settings, as follows:
  - To save the new settings in an existing configuration file, click **Save** in the **File** menu.
  - To save the new settings in a new configuration file, click **Save As** in the **File** menu. The software prompts you for the name of the new configuration file.

---

**Note:** When naming a new configuration file, use a file name with the .CFG extension (for example, MYFILE.CFG) to make the file easier to locate for possible future modification.

---

6. To exit the configuration utility, click **Exit** on the DAS-Scan CFG Panel.

# 3

## System Assembly

This chapter describes the following:

- How to label channel routes
- How to mount SCAN-STP screw terminal panels
- How to connect field wiring
- How to mount a SCAN-CH chassis
- How to attach SCAN-CAB-64 cables to the chassis
- How to set up and test chassis power
- How to install SCAN-BRD assemblies
- How to install the SCAN-AD-HR interface board in the computer
- How to connect the SCAN-AD-HR interface board to the chassis
- How to attach SCAN-CAB-64 cables to the SCAN-STP screw terminal panels
- How to connect an external clock/trigger/gate
- How to attach a signal-conditioning backplane

### Labelling Channel Routes

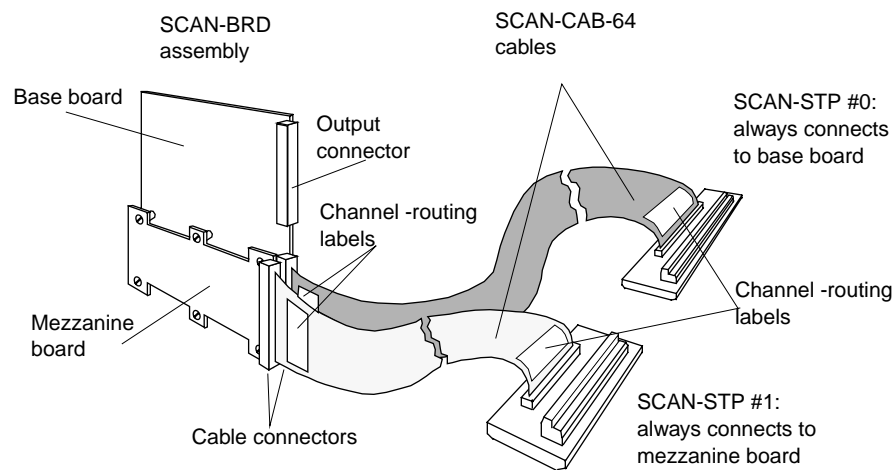
---

Before you assemble your DAS-Scan system, refer to your channel-routing map and mark the channel-routing labels on the SCAN-CAB-64 cables with the following information:

- The chassis identification number
- The chassis slot number

- The name or number of the attached SCAN-STP
- The thumbwheel address of the attached SCAN-BRD assembly
- The channel number range

The channel-routing labels are located on the SCAN-CAB-64 cables as shown in Figure 3-1.



**Figure 3-1. Channel-Routing Labels**

## Mounting the SCAN-STP Screw Terminal Panels

---

To mount the SCAN-STP screw terminal panels, perform the following steps:

1. Mount the DIN rails on a convenient surface, such as the rear door of a rack. (You need eight inches of DIN rail for each SCAN-STP.)
2. Snap the SCAN-STPs onto the DIN rails.
3. Mark each SCAN-STP according to your channel-routing map.

---

**Warning** Do not attach the SCAN-CAB-64 cables to the SCAN-STP screw terminal panels until system assembly is complete. Doing so before assembly is complete could expose you to dangerous voltage levels.

---

## Connecting Field Wiring

---

To connect field wiring to SCAN-STP screw terminals, perform the following steps:

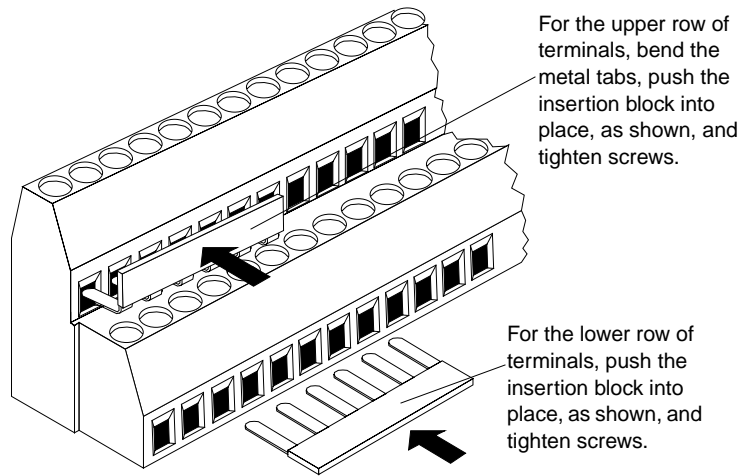
1. Connect wiring from external signal sources to the screw terminals of the SCAN-STP-V, SCAN-STP-I, or SCAN-STP-TC screw terminal panel. Refer to the following sections for information on connecting specific types of signals.

---

**Caution:** Any input signal in excess of  $22 V_{\text{peak}}$  from analog ground (channel 31 negative) can damage multiplexer circuitry on the attached SCAN-BRD assembly.

---

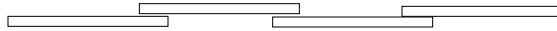
2. Connect all unused inputs to analog power ground (marked G).
3. If you are using insertion blocks (SCAN-SE-INSERT) to short the screw terminals of a SCAN-STP, install these blocks as shown in Figure 3-2.



**Figure 3-2. Installing Insertion Blocks**

If you use a series of overlapping insertion blocks, stagger the insertion blocks for optimum contact, as shown in Figure 3-3.

Stagger overlapping insertion blocks this way:



Do not install overlapping insertion blocks this way:



**Figure 3-3. Installing Overlapping Insertion Blocks**

---

**Note:** The insertion blocks are designed to short six adjacent SCAN-STP screw terminals together. To short fewer than six screw terminals together, use wire.

---

4. Tighten all screws on unused terminals to their inner limits to minimize the effects of electrostatic discharge.

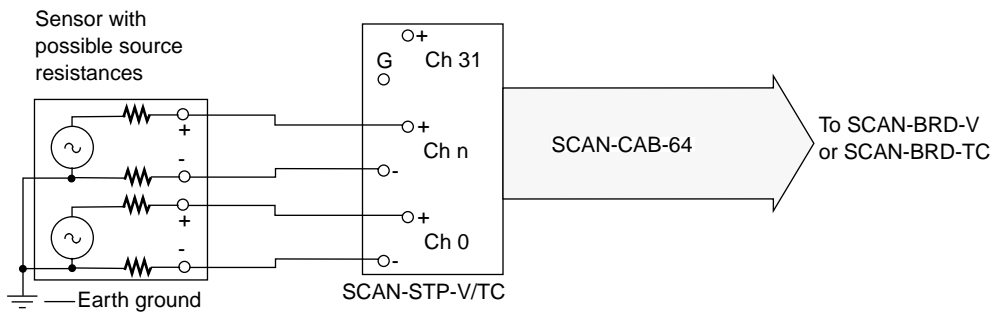
## Nonisolated Voltage Measurements

Figure 3-4 and Figure 3-5 show how to connect differential and single-ended signal sources to the inputs of a SCAN-STP-V or SCAN-STP-TC screw terminal panel for nonisolated measurements.

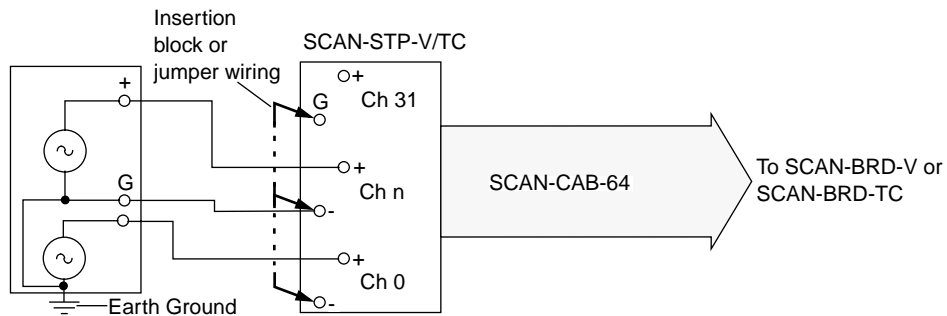
---

**Note:** Use differential connections where possible to minimize ground loops and voltage drops in the field wiring circuit.

---



**Figure 3-4. Differential Voltage Inputs (Nonisolated)**



**Figure 3-5. Single-Ended Voltage Inputs (Nonisolated)**

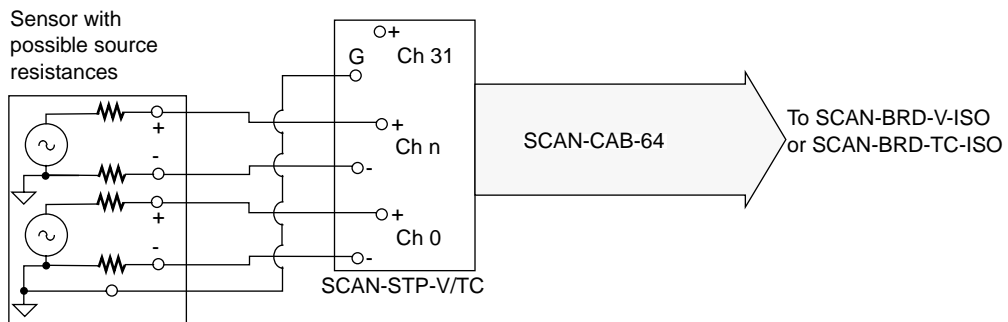
## Isolated Voltage Measurements

Figure 3-6 and Figure 3-7 show how to connect differential and single-ended signal sources to the inputs of a SCAN-STP-V or SCAN-STP-TC screw terminal panel for isolated measurements.

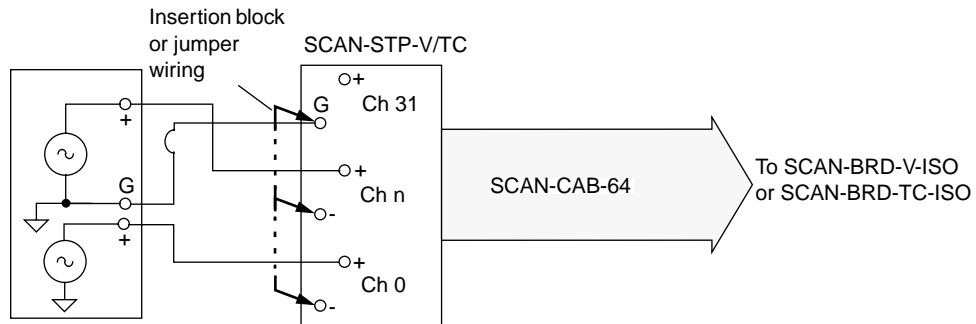
---

**Note:** Use differential connections where possible to minimize ground loops and voltage drops in the field wiring circuit.

---



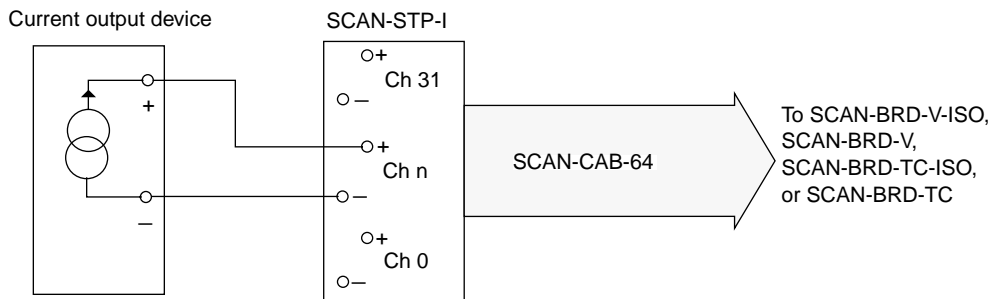
**Figure 3-6. Differential Voltage Inputs (Isolated)**



**Figure 3-7. Single-Ended Voltage Inputs (Isolated)**

## Current Measurements

Figure 3-8 shows how to connect current signal sources to the inputs of a SCAN-STP-I screw terminal panel.

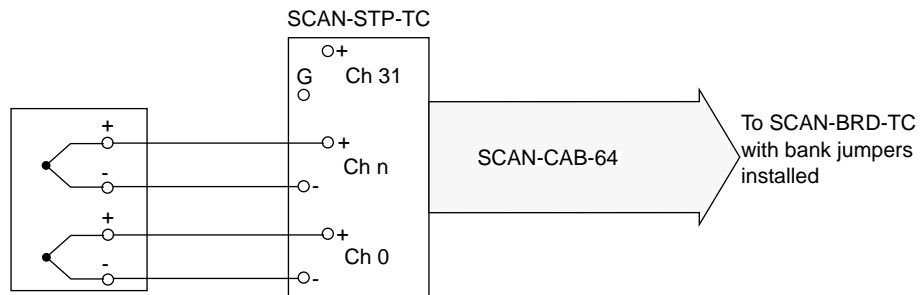


**Figure 3-8. Current Inputs**

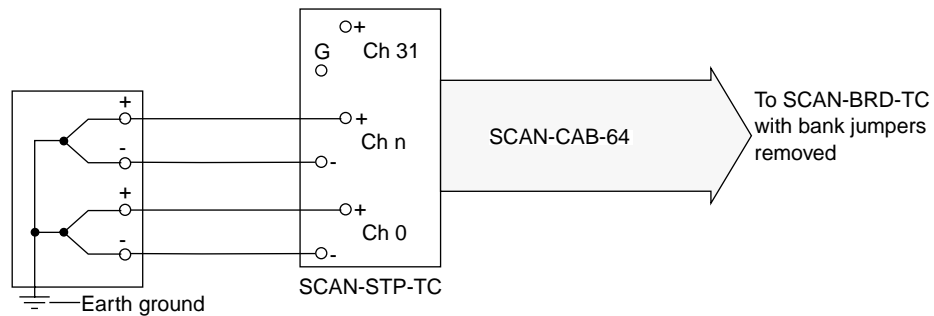


## Nonisolated Thermocouples Measurements

Figure 3-9 and Figure 3-10 show how to connect floating and grounded thermocouples to the inputs of a SCAN-STP-TC screw terminal panel for nonisolated measurements.



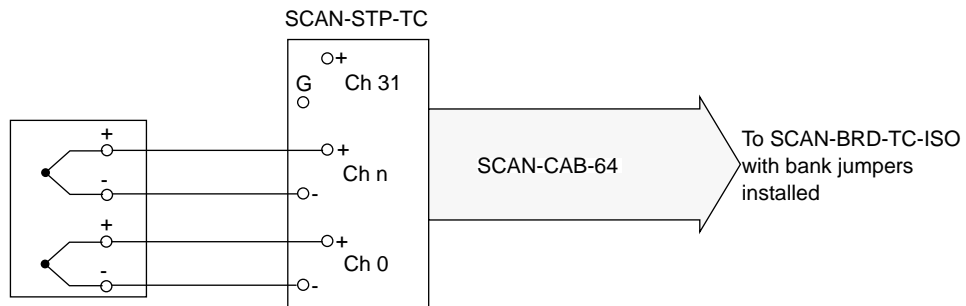
**Figure 3-9. Floating Thermocouple Inputs (Nonisolated)**



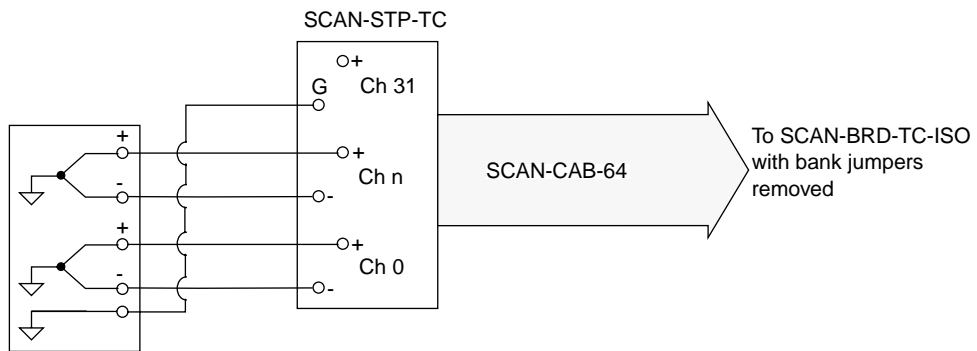
**Figure 3-10. Grounded Thermocouple Inputs (Nonisolated)**

## Isolated Thermocouples Measurements

Figure 3-11 and Figure 3-12 show how to connect floating and grounded thermocouples to the inputs of a SCAN-STP-TC screw terminal panel for isolated measurements.



**Figure 3-11. Floating Thermocouple Inputs (Isolated)**

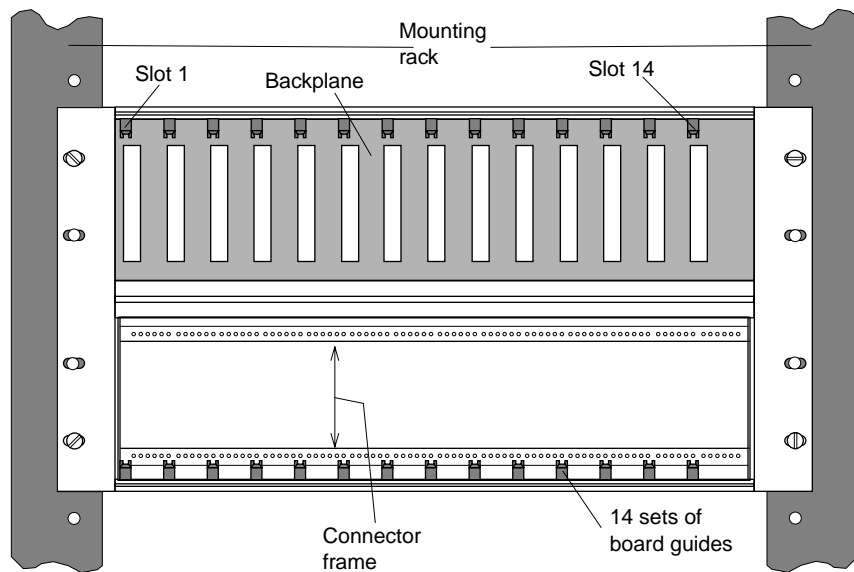


**Figure 3-12. Grounded Thermocouple Inputs (Isolated)**

## Mounting a Chassis

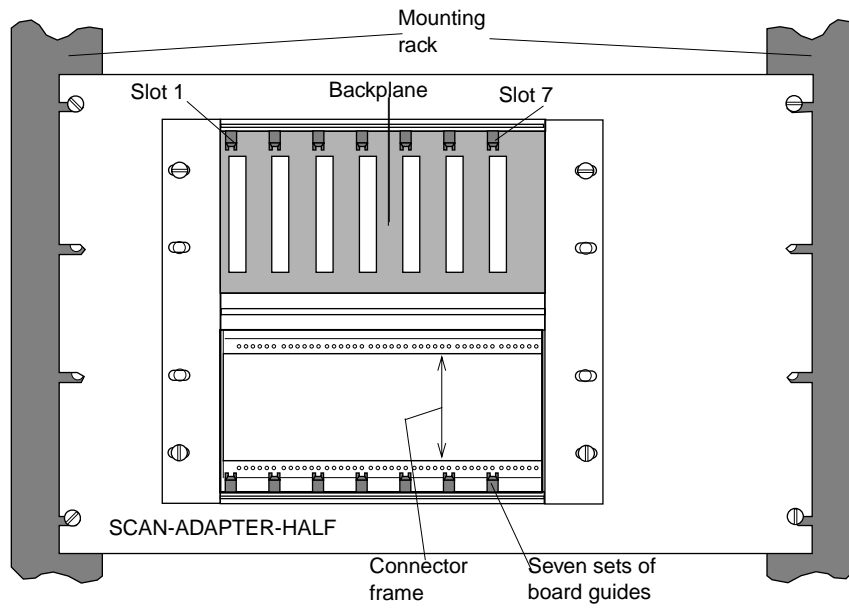
---

The design of your chassis allows either rack mounting or surface mounting. Rack mounting uses any standard 19-inch rack for both the full-size and half-size chassis. The full-size chassis mounts directly into the 19-inch rack, as shown in Figure 3-13.



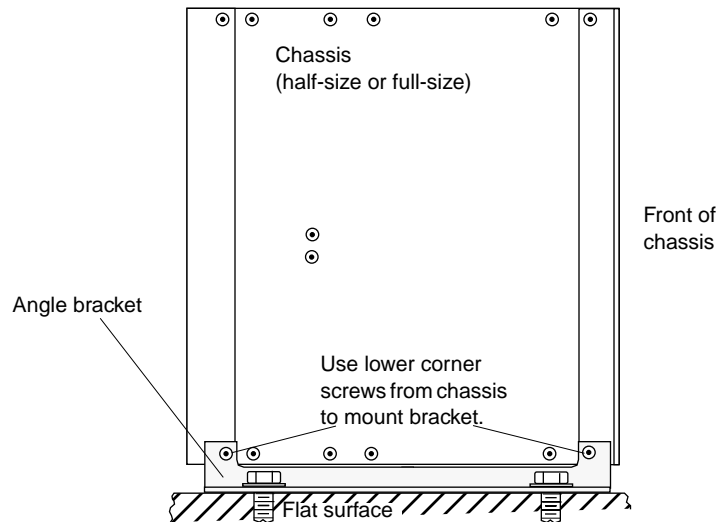
**Figure 3-13. Full-Size Chassis in Mounting Rack**

The half-size chassis requires an adapter (SCAN-ADAPTER-HALF) to fit a 19-inch rack, as shown in Figure 3-14.



**Figure 3-14. Half-Size Chassis in Mounting Rack**

Surface mounting uses optional angle brackets (SCAN-MOUNT-PAIR) fastened to the sides of the chassis, as shown in Figure 3-15.



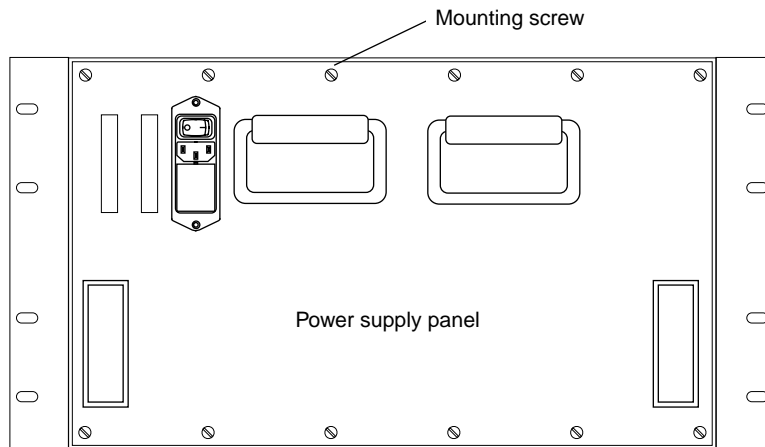
**Figure 3-15. Mounting a Chassis on a Flat Surface (Side View)**

## **Attaching the SCAN-CAB-64 Cables to the Chassis**

---

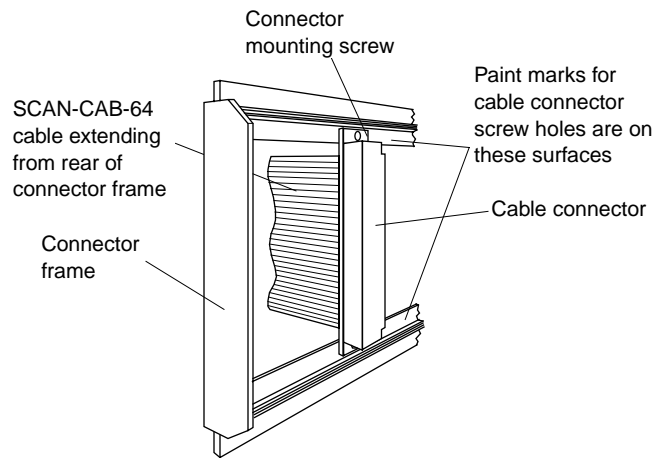
To attach SCAN-CAB-64 cables to the chassis, perform the following steps:

1. Remove the AC power cord (if installed).
2. Loosen the mounting screws along the upper and lower edges of the power supply panel at the rear of the chassis. The location of the mounting screws is shown in Figure 3-16.



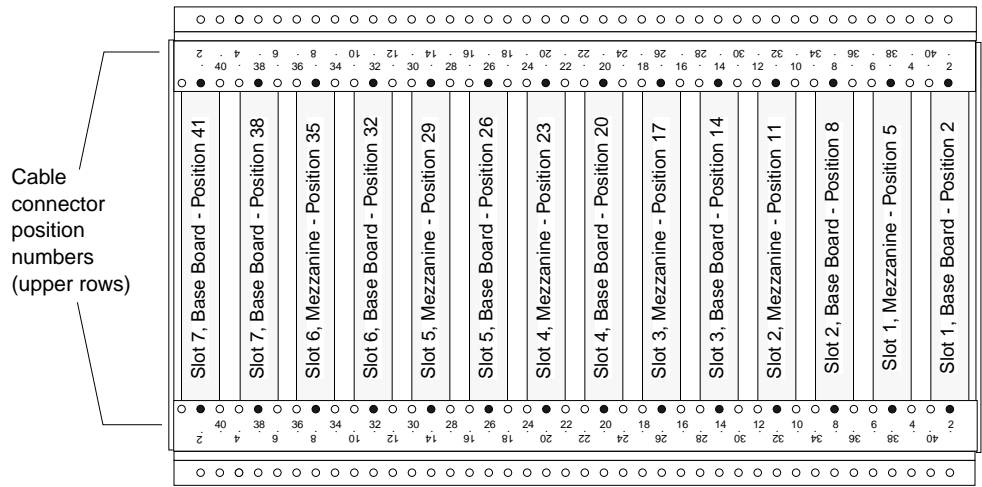
**Figure 3-16. Mounting Screws**

3. Remove the power supply panel from the rear of the chassis, carefully disconnecting the inner power cable from the chassis backplane.
4. Remove the cable clamp(s) from the inner wall of the chassis (one clamp for the half chassis; two clamps for the full chassis).
5. Locate the SCAN-CAB-64 cable labelled for connection to the base board in slot 1 of the chassis.
6. Position the SCAN-CAB-64 cable in the connector frame as shown in Figure 3-17, taking care to orient the cable connector notches correctly.

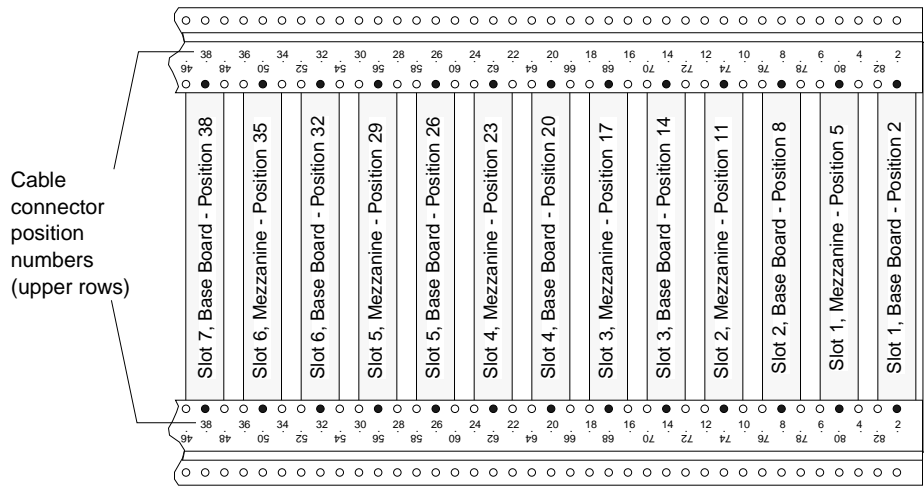


**Figure 3-17. Connector Frame**

7. Slide the cable connector to the marked screw mounting holes for the slot 1 base board connector. (The screw mounting holes for each slot are marked with paint on the front side and are numbered on the rear side, as shown in Figure 3-18 and Figure 3-19.)



**Figure 3-18. Rear View of Connector Frame (Half-Size Chassis)**



**Figure 3-19. Partial Rear View of Connector Frame (Full-Size Chassis)**



Table 3-1 shows the connector frame position numbers for the boards in each slot of a chassis.

**Table 3-1. Connector Frame Position Numbers**

<b>Chassis Slot</b>	<b>SCAN-CAB-64 Cable Connector Destination</b>	<b>Connector Position</b>
1	Base board	2
	Mezzanine board	5
2	Base board	8
	Mezzanine board	11
3	Base board	14
	Mezzanine board	17
4	Base board	20
	Mezzanine board	23
5	Base board	26
	Mezzanine board	29
6	Base board	32
	Mezzanine board	35
7	Base board	38
	Mezzanine board	41
8	Base board (full chassis only)	44
	Mezzanine board (full chassis only)	47
9	Base board (full chassis only)	50
	Mezzanine board (full chassis only)	53
10	Base board (full chassis only)	56
	Mezzanine board (full chassis only)	59
11	Base board (full chassis only)	62
	Mezzanine board (full chassis only)	65

**Table 3-1. Connector Frame Position Numbers (cont.)**

<b>Chassis Slot</b>	<b>SCAN-CAB-64 Cable Connector Destination</b>	<b>Connector Position</b>
12	Base board (full chassis only)	68
	Mezzanine board (full chassis only)	71
13	Base board (full chassis only)	74
	Mezzanine board (full chassis only)	77
14	Base board (full chassis only)	80
	Mezzanine board (full chassis only)	83

8. Using the supplied screwdriver, tighten the connector mounting screws until firm, then back off a half turn to allow the connector to float in its mount.
9. Repeat steps 7 to 9 for each of the remaining cables and their destinations.
10. In a half-size chassis, carefully stack all cables neatly against the inside wall of the chassis and replace the cable clamp, securing the stacked cables against the wall.

In a full-size chassis, divide the cables into two equal groups for stacking and clamping against both inside walls of the chassis.

11. If an AC power cord is not installed on the power supply panel, refer to the next section for information on installing a power cord.

If an AC power cord is installed on the power supply panel, replace the power supply panel, taking care to align and engage the connector on the inner side of the panel with the mating connector on the rear side of the chassis backplane.

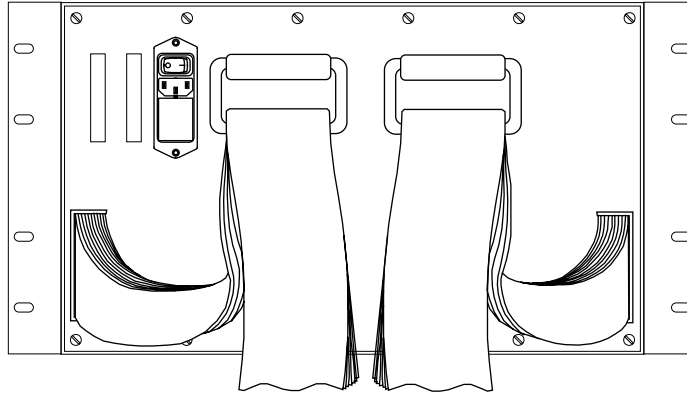
---

**Caution:** Use care in aligning and engaging the connectors between the power supply panel and the backplane to avoid breaking the connector assembly.

---

12. Adjust the cable clamps on the power supply panel to further secure the stacked cables extending through the panel.

13. Run the stacked cables through the hangers on the back of the power supply panel, as shown in Figure 3-20.



**Figure 3-20. SCAN-CAB-64 Cables on Hangers**

14. Replace the mounting screws to secure the power supply panel in place.

---

**Warning**

Do not attach the free ends of the SCAN-CAB-64 cables to the SCAN-STP screw terminal panels until system assembly is complete. Doing so before assembly is complete could expose you to dangerous voltage levels.

---

## Setting Up and Testing Chassis Power

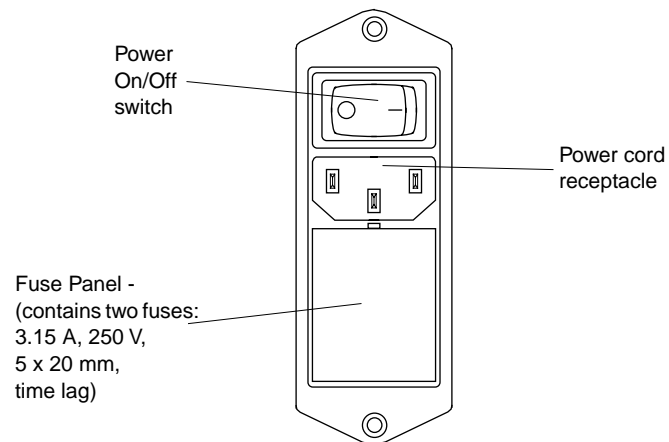
---

A SCAN-CH-FULL or a SCAN-CH-HALF chassis is equipped with an internal power supply. A SCAN-CH-FULL/NO PWR or a SCAN-CH-HALF/NO PWR chassis contains no internal power supply and must be supplied with +15 V, -15 V, and +5 V from external sources.

This section describes how to set up and test internally and externally powered chassis.

### Setting Up an Internally Powered Chassis

The power supply panel of an internally powered chassis contains an AC power cord receptacle. Plug an IEC (International Electrotechnical Commission) 320 power cord into the power cord receptacle, shown in Figure 3-21.



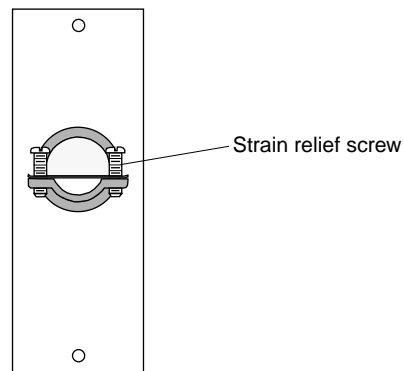
**Figure 3-21. Power Cord Receptacle (Internal Power)**

## Setting Up an Externally Powered Chassis

The power cord for an external power supply must be 4-wire with wire sizes large enough (greater than 18 gauge) to carry 2.5 A each. Wires of the power cord must carry power from +15 V, -15 V, and +5 V supplies; the fourth wire is for ground.

If your chassis is not equipped with an internal power supply, perform the following steps:

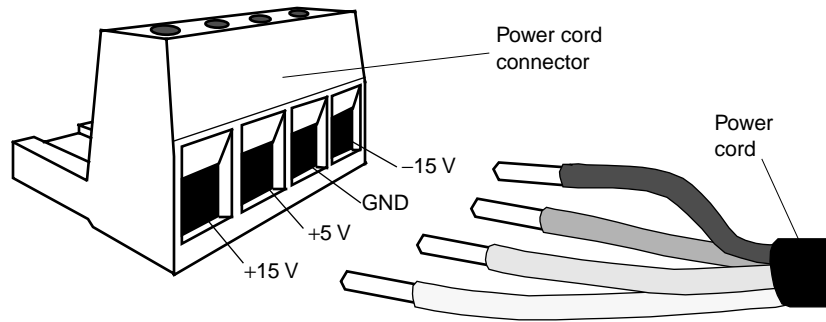
1. Feed at least 12 inches of the chassis end of the power cord through the strain relief in the power supply panel. The strain relief is shown in Figure 3-22.



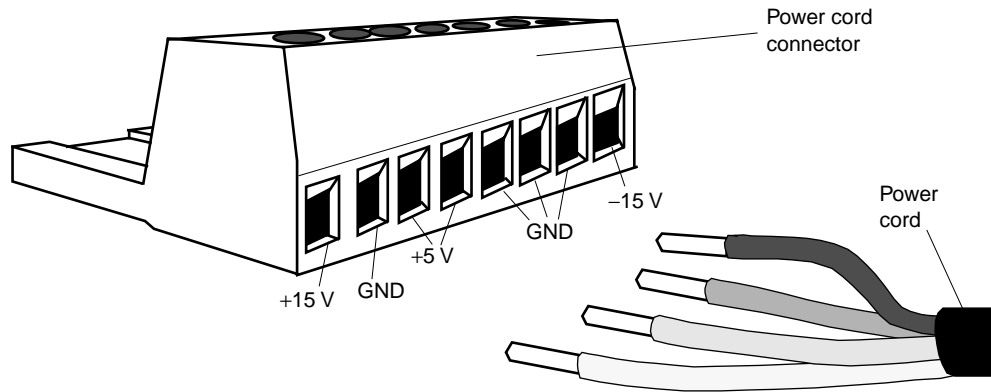
**Figure 3-22. Strain Relief**

2. Tighten the two strain relief screws until the power cord is secure.
3. Remove about two inches of the outer cover of the power cord to expose the four inner wires.
4. Strip each of the inner wires to expose about 3/8 inch of bare wire.
5. Remove the power cord connector from its mating connector on the chassis backplane.

6. Insert and secure each of the bare wire stubs in the appropriate screw terminal of the power cord connector. Figure 3-23 shows the power cord connector for the SCAN-CH-HALF chassis; Figure 3-24 shows the power cord connector the SCAN-CH-FULL chassis.



**Figure 3-23. Voltage Connections for the SCAN-CH-HALF Power Cord Connector**



**Figure 3-24. Voltage Connections for the SCAN-CH-FULL Power Cord Connector**

7. With external power off, replug the power cord connector into the mating connector on the chassis backplane.

## Checking Power Supply Operation

To check that power is being supplied to the SCAN-CH chassis, perform the following steps:

1. Plug the power cord into the wall.
2. Turn the power switch on the rear of the SCAN-CH chassis to the ON (O) position.
3. Look at the front of the chassis and observe the three LED power indicators on the lower left side of the chassis backplane.

If all three indicators are ON, +15 V, -15 V, and +5 V are present and the power supply is operating properly. Turn the power switch on the rear of the SCAN-CH chassis back to the OFF (-) position and proceed to the next section.

If the chassis has internal power and none of the indicators turn on, check the fuses in the power cord receptacle; refer to Figure 3-21 on page 3-19. If the fuses are intact, return the chassis for replacement of the power supply; refer to page 5-7 for instructions.

If the chassis has internal power and only one or two indicators turn on or blink, return the chassis for replacement of the power supply; refer to page 5-7 for instructions.

If the chassis has external power and only one or two indicators turn on or blink, check the external power supply.

## Installing and Removing a SCAN-BRD Assembly

---

To install a SCAN-BRD assembly, perform the following steps:

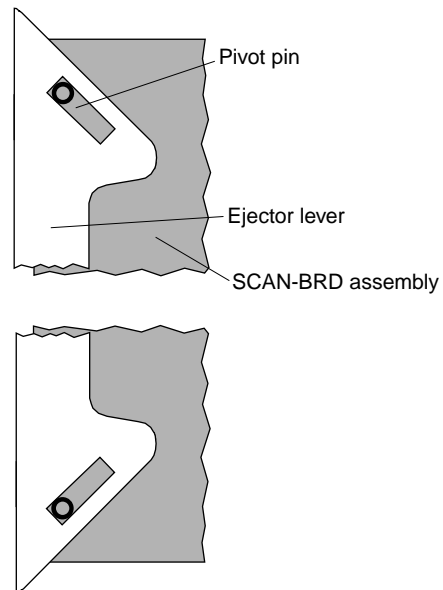
1. Make sure that power to the SCAN-CH chassis is OFF.

---

**Caution:** Installing or removing a SCAN-BRD assembly while power is ON can damage your SCAN-BRD assembly and/or the power supply.

---

2. Refer to your channel-routing maps for the assembly address assigned to the chassis slot you intend to use, and check the settings of the thumbwheels on the SCAN-BRD assembly for the correct assembly address.
3. Make sure that the pivot pins are positioned so that the ejector levers on the front corners of the SCAN-BRD assembly are positioned for insertion of the assembly in the chassis. Refer to Figure 3-25.



**Figure 3-25. Ejector Levers Positioned for Inserting a SCAN-BRD Assembly**

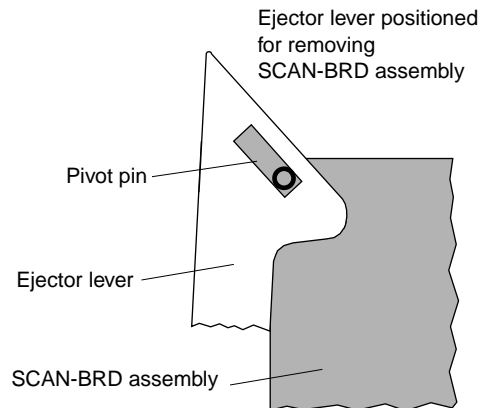
4. Insert the SCAN-BRD assembly in the appropriate chassis slot so that the three connectors at the bottom of the assembly fit securely in the slot.



5. Refer to Table 3-1 on page 3-16 for the connector position numbers associated with the chassis slot, and make sure that the base board and the mezzanine board of the SCAN-BRD assembly fit into the SCAN-CAB-64 cable connector at the appropriate position of the connector frame. For example, if you are using chassis slot 1, fit the base board into the SCAN-CAB-64 cable connector at position 2 and the mezzanine board into the SCAN-CAB-64 cable connector at position 5.
6. Repeat steps 2 to 5 for each of the remaining SCAN-BRD assemblies.

To remove a SCAN-BRD assembly from a chassis, perform the following steps:

1. Position the pivot pins so that the ejector levers on the front corners of the SCAN-BRD assembly are positioned for removal of the assembly from the chassis, as shown in Figure 3-26.



**Figure 3-26. Ejector Lever Positioned for Removing a SCAN-BRD Assembly**

2. Gently pull both ejector levers to force them against the top and bottom chassis edges until the SCAN-BRD assembly is free of the chassis connectors and can slide easily out of the chassis.
3. Return the levers to their insertion positions; refer to Figure 3-25 on page 3-23.

## Installing the SCAN-AD-HR Interface Board

---

To install your SCAN-AD-HR interface board in an accessory slot of your computer, perform the following steps:

1. Turn power to the computer and all attached equipment OFF.

---

**Caution:** Installing or removing a board while power is ON can damage your board and the computer power supply.

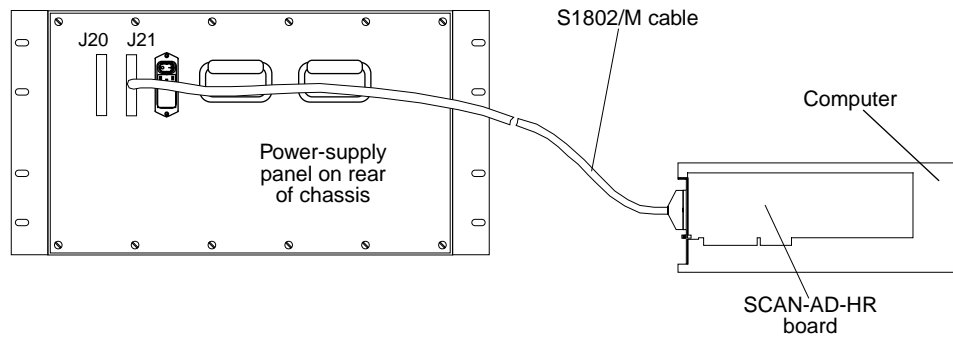
---

2. Remove the computer chassis cover.
3. Select an unoccupied accessory slot, and remove the corresponding cover plate from the I/O connector panel. The SCAN-AD-HR interface board requires a full-size slot.
4. Insert and secure the board in the selected slot.
5. Replace the computer cover.

## Connecting the SCAN-AD-HR to the Chassis

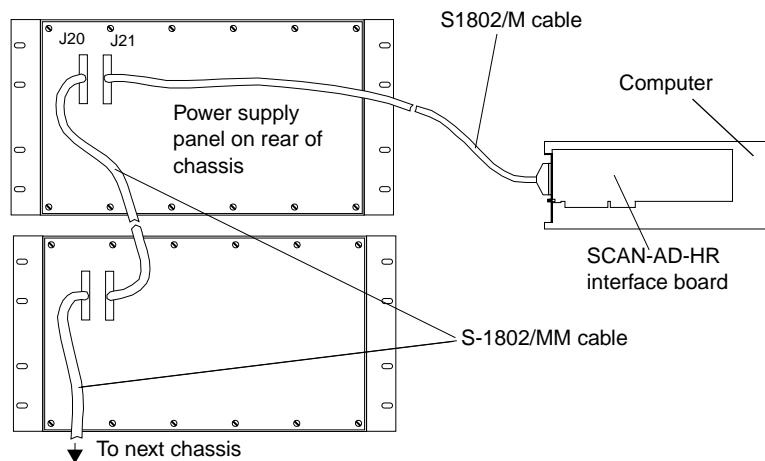
---

To connect the SCAN-AD-HR interface board to the first chassis in your DAS-Scan system, use the S-1802/M cable. Attach one end of the S-1802/M cable to the main I/O connector of the SCAN-AD-HR board and the other end of the cable to either one of the two connectors (J20 or J21) on the power supply panel on the rear of the chassis. Refer to Figure 3-27.



**Figure 3-27. Connecting SCAN-AD-HR Board to Chassis**

To connect additional chassis to the first chassis, use S-1802/MM cables. Attach each end of the cable to one of the two connectors (J20 or J21) on power supply panel on the rear of the chassis. Refer to Figure 3-28.



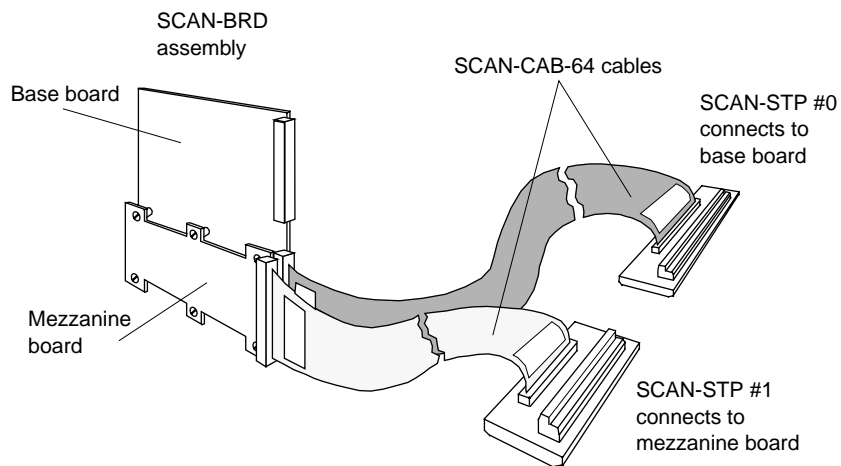
**Figure 3-28. Connecting Multiple Chassis**

## Attaching SCAN-CAB-64 Cables to the SCAN-STPs

---

When all system components are installed and the chassis covers are secured to the chassis, attach the SCAN-CAB-64 cables to the SCAN-STP screw terminal panels.

Refer to your channel-routing maps for the SCAN-BRD assembly assigned to each chassis slot, and refer to Table 3-1 on page 3-16 for the connector positions associated with each chassis slot. Make sure that you attach SCAN-STP #0 to the SCAN-CAB-64 cable attached to the base board and SCAN-STP #1 to the SCAN-CAB-64 cable attached to the mezzanine board. For example, if you are using chassis slot 1, attach SCAN-STP #0 to the SCAN-CAB-64 cable attached to position 2 and that SCAN-STP #1 to the SCAN-CAB-64 cable attached to position 5. Refer to Figure 3-29.

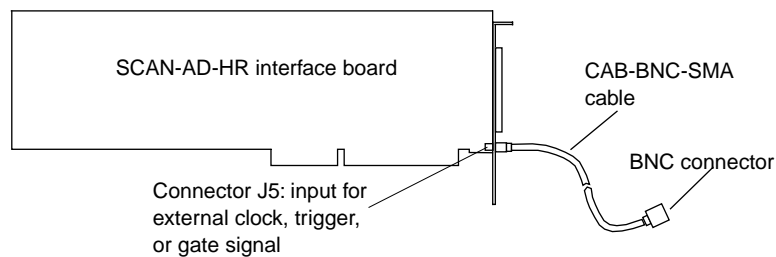


**Figure 3-29. Attaching SCAN-CAB-64 Cables to the SCAN-STPs**

## Connecting an External Clock/Trigger/Gate

---

Connect an external clock, trigger, or gate signal to the SCAN-AD-HR interface board through a CAB-SMA-BNC accessory cable. Connect the cable to SMA connector J5 on the SCAN-AD-HR interface board, as shown in Figure 3-30.



**Figure 3-30. Connecting an External Clock/Trigger/Gate Signal**

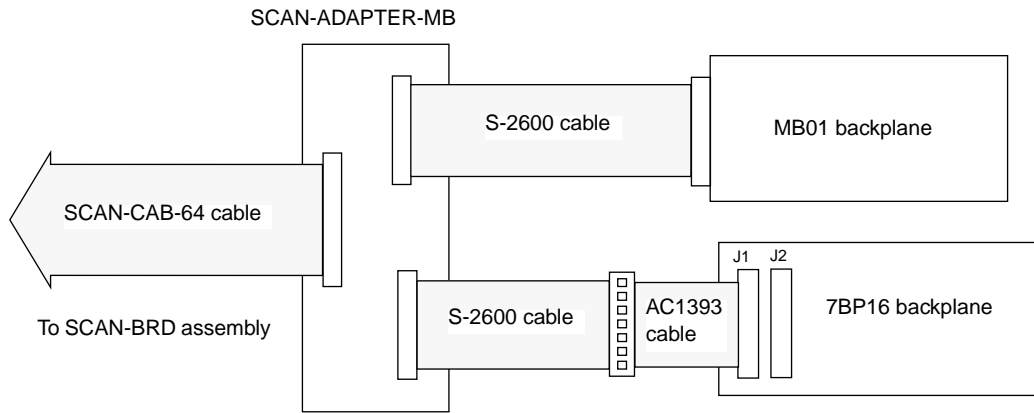
## Attaching Signal-Conditioning Backplanes

---

If you want to provide per channel isolation and signal-conditioning to your DAS-Scan system, you can use MB01 backplanes (with plug-in MB Series modules) or 7BP16 backplanes (with plug-in 7B Series modules).

To attach a signal-conditioning backplane to your DAS-Scan system, connect the SCAN-CAB-64 cable from the SCAN-BRD assembly to the 50-pin connector of a SCAN-ADAPTER-MB adapter. Then, connect the backplane to the 26-pin connector of the SCAN-ADAPTER-MB adapter using an S-2600 cable. Note that if you are using a 7BP16 backplane, you must use an AC1393 adapter cable to connect the S-2600 cable to either of the two I/O connectors (J1 or J2) on the 7BP16 backplane.

Figure 3-31 illustrates how to attach an MB01 backplane and a 7BP16 backplane to your DAS-Scan system.



**Figure 3-31. Connecting Signal-Conditioning Backplanes**

Refer to the *MB Series User's Guide* for more information about the MB01 backplane. Contact Analog Devices, Inc. (800 426-2564) for more information about the 7BP16 backplane.

# 4

## Testing the System

This chapter describes how to use the DAS-Scan Control Panel (CTLSCAN.EXE) to test the functions of a DAS-Scan system by testing one SCAN-BRD assembly at a time. The control panel is shipped with the ASO-SCAN software package.

---

**Note:** Before using the control panel, it is recommended that you install the Keithley Memory Manager to ensure the allocation of a memory buffer large enough for control panel needs. Refer to Appendix B for more information about the Keithley Memory Manager.

---

To use the control panel, perform the following steps:

1. Make sure that your DAS-Scan system is set up and that field wiring is connected to the inputs of the SCAN-STP screw terminal panels; refer to page 3-3.
2. Power up your DAS-Scan system and make sure that power is being supplied to the chassis (refer to page 3-22).
3. *If you are using Windows 3.1 or Windows for Workgroups 3.11:*
  - Double-click the control panel icon in the DAS-Scan program group.

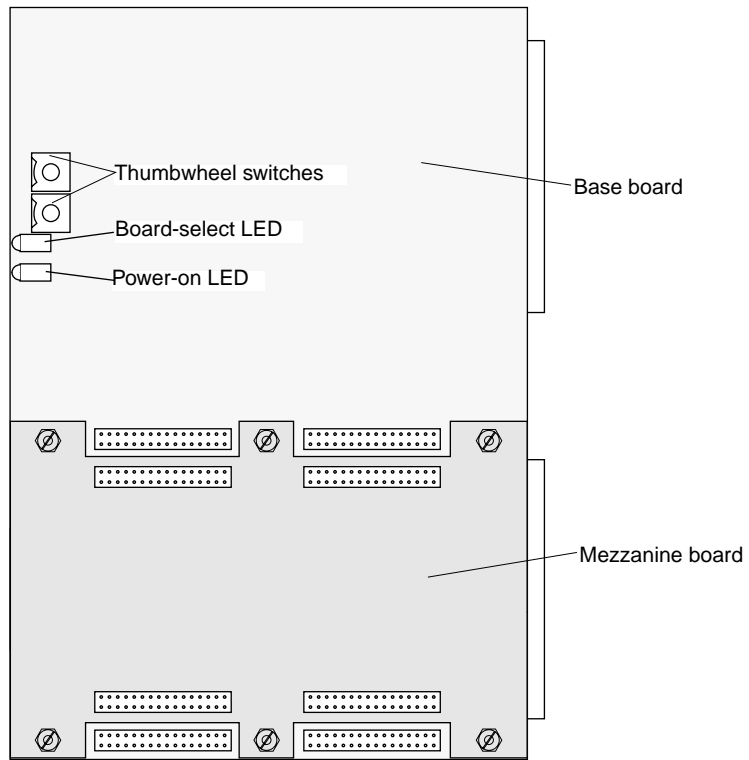
*If you are using Windows 95:*

- Point to **Programs, Keithley DAS-Scan, and DAS-Scan Control Panel** on the **Start** menu.

The software displays the Open Configuration File dialog box, asking you to specify the configuration file to use.

4. Select the appropriate configuration file.  
The control panel displays buttons and a list box that allow you to acquire and monitor data.
5. Click **Setup** to display the analog input setup panel.
6. Under **SCAN-BRD Address**, select the assembly address of the SCAN-BRD assembly to be tested. (Note that the control panel tests one SCAN-BRD assembly at a time.)
7. To set up and perform an operation, select the appropriate buttons. To obtain information on the setup and performance of an operation, click **Help** or click **Contents** in the **Help** menu.
8. While the operation is in progress on the SCAN-BRD assembly, check the board-select LED; refer to Figure 4-1. The board-select LED should light whenever any channel on the SCAN-BRD assembly is sampled. If the LED does not light when it should, make sure that the assembly address selected in step 6 matches the address settings of the thumbwheel switches on the SCAN-BRD assembly.





**Figure 4-1. Locations of the Power-On and Board-Select LEDs**

9. Repeat steps 5 to 8 for each SCAN-BRD assembly you want to test.
10. When you finish using the control panel, click **Exit** on the **File** menu to quit the program.

# 5

## Troubleshooting

This chapter describes the following:

- How to check the computer
- How to check the SCAN-AD-HR interface board
- How to check the accessory slot and I/O connections
- How to check chassis power
- How to check the SCAN-BRD assemblies and inputs
- How to get technical support

### Checking the Computer

---

To determine whether an operating problem is in the computer or your DAS-Scan system, perform the following steps:

1. Turn power to the computer OFF.
2. Disconnect the S-1802/M cable from your SCAN-AD-HR interface board and remove the board from the computer.

---

**Caution:** Removing a board with the power ON can damage your board and/or computer.

Before handling a board, discharge static electricity from yourself either by wearing a grounded wrist strap or by placing one hand firmly on a metal portion of the computer chassis (your computer must be turned OFF but grounded).

---

3. Turn power to the computer ON.
4. Check computer operation by running one or more programs other than those involving the DAS-Scan system.

If the computer fails to operate normally, the problem is in the computer; resolve your computer problem before reinstalling the SCAN-AD-HR interface board.

If the computer operates normally, proceed to the next section to check your SCAN-AD-HR.

## Checking the SCAN-AD-HR Interface Board

---

To check the performance of your SCAN-AD-HR interface board, perform the following steps:

1. Turn power to the computer OFF and reinstall your SCAN-AD-HR interface board.

---

**Caution:** Installing or removing a board with the power ON can cause damage to your board and/or computer.

---

2. With the S-1802/M cable disconnected from the SCAN-AD-HR, reapply power to the computer.
3. Check computer operation by running one or more programs other than those involving the DAS-Scan system.

If the computer fails to operate normally, the problem is in the SCAN-AD-HR; refer to Table 5-1 for a list of possible problems and solutions.

If the computer operates normally, proceed to the next section to check your SCAN-BRD assemblies.

**Table 5-1. Troubleshooting Information**

<b>Symptom</b>	<b>Possible Cause</b>	<b>Possible Solution</b>
SCAN-AD-HR interface board does not respond	Base address is unacceptable.	Make sure that the base address specified in the configuration file matches the setting of the base I/O address switch on the board. Make sure that no other system resource is using any of the 16 I/O locations beginning at the specified base address. If necessary, reconfigure the base address. Refer to page 2-8 and page 2-16.
	The interrupt level is unacceptable.	Make sure no other system resource is using the interrupt level specified in the configuration file. If necessary, reset the interrupt level.
	The configuration file is incorrect.	Check the settings in the configuration file.
	The SCAN-AD-HR interface board is incorrectly aligned in the accessory slot.	Check the board for proper seating.
	The SCAN-AD-HR interface board is damaged.	Contact Keithley MetraByte for technical support; refer to page 5-8.
Intermittent operation	The I/O bus speed is in excess of 8 MHz.	Reduce I/O bus speed to a maximum of 8 MHz (to change the I/O bus speed, run BIOS setup). See your computer documentation for instructions on running BIOS setup.
	Vibrations or loose connections exist.	Cushion source of vibration and tighten connections.
	A system board is overheating.	Check environmental and ambient temperature; refer to temperature specifications in Appendix A.
	Electrical noise exists.	Provide better shielding or reroute unshielded wiring.

**Table 5-1. Troubleshooting Information (cont.)**

<b>Symptom</b>	<b>Possible Cause</b>	<b>Possible Solution</b>
Data appears to be invalid	The I/O bus speed in excess of 8 MHz.	Reduce I/O bus speed to a maximum of 8 MHz (to change the I/O bus speed, run BIOS setup). See the documentation for your computer for instructions on running BIOS setup.
	An open connection exists.	Check wiring to screw terminals.
	Another system resource is using the specified base address, or the setting of the base I/O address switch does not match the base address setting in the configuration file.	Reconfigure the base address of the SCAN-AD-HR interface board. Check the I/O assignments of other system resources and reconfigure, if necessary.
	The transducer is not connected to channel being read.	Check the transducer connections.
	The transducer is a single-ended type.	Check the transducer specifications and the wiring to the SCAN-STP screw terminal panel.
	Clock rate is too fast.	Refer to throughput rates and gains in Appendix A for correct rate.

**Table 5-1. Troubleshooting Information (cont.)**

<b>Symptom</b>	<b>Possible Cause</b>	<b>Possible Solution</b>
Computer does not boot.	The SCAN-AD-HR interface board is not seated properly.	Check the installation of the SCAN-AD-HR.
	The base address setting of the SCAN-AD-HR interface board conflicts with that of another system resource.	Check the base address settings of your system resources; each base I/O address must be unique.
	The power supply of the computer is too small to handle all the system resources.	Check the needs of all system resources and obtain a larger power supply.
	The interrupt setting for the SCAN-AD-HR interface board conflicts with the setting for another system resource.	Use the configuration utility to select another interrupt.
	The DMA setting for the SCAN-AD-HR interface board conflicts with the setting for another resource.	Use the configuration utility to select another DMA setting.
System lockup	A timing error occurred.	Restart your computer.

If you cannot identify the problem using the information in Table 5-1 and you have another SCAN-AD-HR interface board that you know is functional, test the accessory slot and I/O connections using the instructions in the next section. If you do not have another board, refer to the instructions on page 5-8 before calling Keithley MetraByte.

## **Checking the Accessory Slot and I/O Connections**

---

To check the computer accessory slot and I/O connections using a SCAN-AD-HR interface board that you know is functional, perform the following steps:

1. Remove computer power, and install a SCAN-AD-HR interface board that you know is functional. Do not connect the rest of the system (leave the S-1802/M cable disconnected).
2. Turn computer power ON and check operation with the functional board in place.

If operation is normal, the problem is in the original SCAN-AD-HR or in the I/O connections; refer to step 3 to further isolate the problem.

If operation fails, the accessory slot or the computer is at fault; check your computer.

3. Use the functional board to check whether the problem is in the original SCAN-AD-HR or in the remainder of the system; turn off computer power and reconnect the remainder of the system.
4. Reapply power and check operation.

If operation is normal, the problem is in the original SCAN-AD-HR; refer to page 5-8 for instructions on returning the original board for repair.

If operation fails, the problem is in the I/O portion of the system; proceed to the next section to check chassis power.

## Checking Chassis Power

---

To check power to the SCAN-CH chassis, perform the following steps:

1. Turn power to the chassis ON.
2. Look at the front of the chassis and observe the three LED power indicators on the lower left side of the chassis backplane.

If all three indicators are ON, +15 V, -15 V, and +5 V are present and the power supply is operating properly. Turn the power switch on the rear of the SCAN-CH chassis back to the OFF (-) position and proceed to the next section.

If the chassis has internal power and none of the indicators turn on, check the fuses in the power cord receptacle; refer to Figure 3-21 on page 3-19. If the fuses are intact, return the chassis for replacement of the power supply; refer to page 5-8 for instructions.

If the chassis has internal power and only one or two indicators turn on or blink, return the chassis for replacement of the power supply; refer to page 5-8 for instructions.

If the chassis has external power and only one or two indicators turn on or blink, check the external power supply.

## **Checking the SCAN-BRD Assemblies and Inputs**

---

To check the SCAN-BRD assemblies and inputs, perform the following steps:

1. With power to the chassis ON, run the DAS-Scan Control Panel, as described in Chapter 4, checking each SCAN-BRD assembly individually.
2. During the test of each SCAN-BRD assembly, make sure that the board-select LED and power-on LED on the assembly are on. (Refer to Figure 4-1 on page 4-3 for the locations of the LEDs.)
3. If problems persist, turn chassis power OFF and remove all SCAN-BRD assemblies from the chassis.
4. Plug in and test one SCAN-BRD assembly at a time (you can swap SCAN-BRD assemblies to locate a faulty one if you keep the address and jumper settings the same).
5. If you isolate the problem to one SCAN-BRD assembly, disconnect the SCAN-CAB-64 cables from the two SCAN-STP screw terminal panels attached to that assembly.
6. Reapply chassis power, and check operation of the system.

If operation is normal, the problem is in one of the SCAN-STP inputs; go to step 7.

If operation fails, the problem is in the SCAN-BRD assembly; refer to page 5-8 for instructions on returning the SCAN-BRD assembly for repair.

7. Determine which SCAN-STP input contains the problem by removing chassis power, connecting one SCAN-STP input, reapplying power, and checking system operation.
8. When you find the faulty SCAN-STP, reconnect it to the SCAN-BRD assembly while disconnecting field wiring from its input terminals.



9. Check system operation with the field wiring disconnected from the SCAN-STP inputs.

If operation is normal, the problem is in one of the SCAN-STP inputs; replace the inputs one by one until the problem input is located; look for the source of the problem and make the necessary correction.

If operation fails, replace the faulty SCAN-STP.

## Technical Support

---

Before returning any equipment for repair, call for technical support at

**(508) 880-3000**

**Monday - Friday, 8:00 A.M. - 6:00 P.M., Eastern Time**

An applications engineer will help you diagnose and resolve your problem over the telephone.

Please make sure that you have the following information available before you call:

<b>SCAN-AD-HR board configuration</b>	Serial #	_____
	Revision code	_____
	Base address setting	_____
	Interrupt level setting	_____
	DMA channel(s)	_____
	External clock, trigger, or gate	_____
<b>SCAN-BRD assembly configuration</b>	Model	_____
	Serial #	_____
	Revision code	_____
	Address setting (0h to 3Fh)	_____
	Unipolar or bipolar mode	_____

**SCAN-BRD  
assembly  
configuration**

Model \_\_\_\_\_  
Serial # \_\_\_\_\_  
Revision code \_\_\_\_\_  
Address setting (0h to 3Fh) \_\_\_\_\_  
Unipolar or bipolar mode \_\_\_\_\_

**SCAN-BRD  
assembly  
configuration**

Model \_\_\_\_\_  
Serial # \_\_\_\_\_  
Revision code \_\_\_\_\_  
Address setting (0h to 3Fh) \_\_\_\_\_  
Unipolar or bipolar mode \_\_\_\_\_

**SCAN-BRD  
assembly  
configuration**

Model \_\_\_\_\_  
Serial # \_\_\_\_\_  
Revision code \_\_\_\_\_  
Address setting (0h to 3Fh) \_\_\_\_\_  
Unipolar or bipolar mode \_\_\_\_\_

**SCAN-BRD  
assembly  
configuration**

Model \_\_\_\_\_  
Serial # \_\_\_\_\_  
Revision code \_\_\_\_\_  
Address setting (0h to 3Fh) \_\_\_\_\_  
Unipolar or bipolar mode \_\_\_\_\_

**SCAN-BRD  
assembly  
configuration**

Model \_\_\_\_\_  
Serial # \_\_\_\_\_  
Revision code \_\_\_\_\_  
Address setting (0h to 3Fh) \_\_\_\_\_  
Unipolar or bipolar mode \_\_\_\_\_

**SCAN-BRD  
assembly  
configuration**

Model \_\_\_\_\_  
Serial # \_\_\_\_\_  
Revision code \_\_\_\_\_  
Address setting (0h to 3Fh) \_\_\_\_\_  
Unipolar or bipolar mode \_\_\_\_\_

**SCAN-BRD  
assembly  
configuration**

Model \_\_\_\_\_  
Serial # \_\_\_\_\_  
Revision code \_\_\_\_\_  
Address setting (0h to 3Fh) \_\_\_\_\_  
Unipolar or bipolar mode \_\_\_\_\_

**SCAN-BRD  
assembly  
configuration**

Model \_\_\_\_\_  
Serial # \_\_\_\_\_  
Revision code \_\_\_\_\_  
Address setting (0h to 3Fh) \_\_\_\_\_  
Unipolar or bipolar mode \_\_\_\_\_

<b>SCAN-BRD assembly configuration</b>	Model	_____
	Serial #	_____
	Revision code	_____
	Address setting (0h to 3Fh)	_____
	Unipolar or bipolar mode	_____
<b>SCAN-BRD assembly configuration</b>	Model	_____
	Serial #	_____
	Revision code	_____
	Address setting (0h to 3Fh)	_____
	Unipolar or bipolar mode	_____
<b>SCAN-BRD assembly configuration</b>	Model	_____
	Serial #	_____
	Revision code	_____
	Address setting (0h to 3Fh)	_____
	Unipolar or bipolar mode	_____
<b>SCAN-BRD assembly configuration</b>	Model	_____
	Serial #	_____
	Revision code	_____
	Address setting (0h to 3Fh)	_____
	Unipolar or bipolar mode	_____
<b>SCAN-BRD assembly configuration</b>	Model	_____
	Serial #	_____
	Revision code	_____
	Address setting (0h to 3Fh)	_____
	Unipolar or bipolar mode	_____
<b>SCAN-BRD assembly configuration</b>	Model	_____
	Serial #	_____
	Revision code	_____
	Address setting (0h to 3Fh)	_____
	Unipolar or bipolar mode	_____
<b>Computer</b>	Manufacturer	_____
	CPU type	_____
	Clock speed (MHz)	_____
	KB of RAM	_____
	Video system	_____
	BIOS type	_____

<b>Operating system</b>	Windows version	_____
<b>Compiler</b>	Language	_____
	Manufacturer	_____
	Version	_____

If a telephone resolution is not possible, request authorization to return your equipment and a Return Material Authorization (RMA) number. Include the RMA number with any documentation regarding the equipment.

When returning equipment for repair, include the following information:

- Your name, address, and telephone number.
- The invoice or order number and date of equipment purchase.
- A description of the problem or its symptoms.
- The RMA number on the outside of the package.

Repackage the equipment, using the original anti-static wrapping, if possible, and handling it with ground protection. Ship the equipment to:

**ATTN: RMA # \_\_\_\_\_**  
**Repair Department**  
**Keithley MetraByte**  
**440 Myles Standish Boulevard**  
**Taunton, Massachusetts 02780**

**Telephone (508) 880-3000**  
**FAX (508) 824-5517**

---

**Note:** If you are submitting your equipment for repair under warranty, you must include the invoice number and date of purchase.

To enable Keithley MetraByte to respond as quickly as possible, you must include the RMA number on the outside of the package.

---

# 6

## Calibration

This chapter describes the following:

- Equipment required for calibrating a DAS-Scan system
- How to use the DAS-Scan Calibration Utility

---

**Note:** The SCAN-AD-HR interface board, SCAN-BRD assemblies, and SCAN-STP-TC screw terminal panels are initially calibrated at the factory. It is recommended that you check the calibration every six months and calibrate again when necessary. If you prefer, you can arrange to return equipment to the factory for recalibration.

---

### Equipment Requirements

---

You need the following equipment to calibrate a DAS-Scan system:

- A low-noise DC calibrator, such as an EDC model 521
- A precision thermometer, such as the model 4600 with a surface probe, available from Ysi.

---

**Note:** The potentiometers and test points you need to access when calibrating your DAS-Scan system are illustrated in the calibration utility. This utility is described in the next section.

---

## Using the Calibration Utility

---

To calibrate your DAS-Scan system, use the DAS-Scan Calibration Utility (CALSCAN.EXE). The calibration utility is shipped with the ASO-SCAN software package and steps you through the full procedure for calibrating a SCAN-AD-HR interface board, a SCAN-BRD assembly, and the CJC sensor on a SCAN-STP-TC.

---

**Note:** Perform the calibration in the following order: (1) SCAN-AD-HR interface board; (2) SCAN-BRD assemblies; (3) CJC sensors on attached SCAN-STP-TC screw terminal panels.

---

To use the calibration utility, perform the following steps:

1. On the SCAN-AD-HR interface board, set the jumper J7 to its 16-bit position.
2. *If you are using Windows 3.1 or Windows 3.11 for Workgroups,* double-click the calibration utility icon in the DAS-Scan program group.

*If you are using Windows 95,* point to **Programs, Keithley DAS-Scan,** and **DAS-Scan Calibration** on the **Start** menu.

The software displays the Open Configuration File dialog box, asking you to specify the configuration file to use.

3. Select the appropriate configuration file.

The main screen of the calibration utility appears.

4. To calibrate a component, refer to the calibration procedure for that component in one of the following sections.

---

**Note:** Allow the system to warm up at least 15 minutes before you begin a calibration procedure.

---

## Calibrating the SCAN-AD-HR Interface Board

Calibrate the SCAN-AD-HR interface board while the board is in the computer and disconnected from the S-1802/M cable.

---

**Caution:** Installing or removing a board while power is ON can damage your board and the computer power supply.

---

Use the calibration utility as follows:

1. Under **System Components** (in the main screen of the calibration utility), click **SCAN-AD-HR**.
2. In the SCAN-AD-HR calibration screen, click **Step 1** and perform the requested setup and calibration procedures that appear on the screen.
3. Click **Step 2**, and perform the requested setup and calibration procedures that appear on the screen.
4. Click **Step 3**, and perform the requested setup and calibration procedures that appear on the screen.
5. Click **Step 4**, and perform the requested setup and calibration procedures that appear on the screen.
6. Click **Close** to return to the main screen.
7. To quit the calibration utility, click **Close**; otherwise, proceed with calibration of the next component.

---

**Note:** After you quit the calibration utility, return jumper J7 (on the SCAN-AD-HR) to its 12-bit position.

---



## Calibrating a SCAN-BRD Assembly

Calibrate a SCAN-BRD assembly while the assembly is in a SCAN-CH chassis connected to the SCAN-AD-HR interface board and while the SCAN-BRD assembly is connected to two SCAN-STP screw terminal panels.

---

**Caution:** Installing or removing a SCAN-BRD assembly while power is ON can damage your assembly and the chassis power supply.

---

Use the calibration utility as follows:

1. Under **System Components** (in the main screen of the calibration utility), click **SCAN-BRD** for a SCAN-BRD-V or a SCAN-BRD-TC, or click **SCAN-BRD-ISO** for a SCAN-BRD-V-ISO or a SCAN-BRD-TC-ISO.
2. In the SCAN-BRD or SCAN-BRD-ISO calibration screen, perform the requested setup and calibration procedures that appear on the screen.

---

**Note:** In the SCAN-BRD-ISO calibration screen, you must first make an offset adjustment of three specified potentiometers and then a gain adjustment of one specified potentiometers.

---

3. When you complete the calibration, click **Close** to return to the main screen.
4. In the main screen, click **Test** to check the accuracy of calibration and to record calibration data.
5. To quit the calibration program, click **Close**; otherwise, proceed with calibration of the next component.

---

**Note:** After you quit the calibration utility, return jumper J7 (on the SCAN-AD-HR) to its 12-bit position.

---

## Calibrating the CJC Sensor

---

**Note:** Calibration of a CJC sensor requires proper use of a precision thermometer for optimum accuracy. Instead of performing your own calibration, you may prefer to return the SCAN-STP-TC screw terminal panel to the factory for calibration to ensure optimum accuracy.

---

To calibrate the CJC sensor on a SCAN-STP-TC screw terminal panel, perform the following steps:

1. On a SCAN-BRD-TC/TC-ISO assembly, set the single-position jumper that enables the CJC circuit. Refer to Figure 2-10 on page 2-15.
2. Install the SCAN-BRD-TC/TC-ISO assembly in a chassis.

---

**Caution:** Installing or removing a SCAN-BRD assembly while power is ON can damage your assembly and the chassis power supply.

---

3. Attach the precision thermometer to the isothermal strip of the SCAN-STP-TC screw terminal panel.
4. Connect the SCAN-STP-TC screw terminal panel to the SCAN-BRD-TC/TC-ISO assembly in the chassis, using a SCAN-CAB-64 cable.
5. Connect the chassis to the SCAN-AD-HR in the computer.
6. Power up the system.

7. Use the calibration utility as follows:
  - Under **System Components** (in the main screen of the calibration utility), click **SCAN-STP**.
  - When the measured temperature (the temperature indicated by the precision thermometer) appears stable, compare the measured temperature with the temperature indicated by the calibration utility.
  - If the two temperatures are equal, calibration of the CJC sensor is complete.  
If the two temperatures differ, adjust the CJC potentiometer until the two temperatures are equal.
  - Click **Close** to quit the calibration utility.

---

**Note:** After you quit the calibration utility, return jumper J7 (on the SCAN-AD-HR) to its 12-bit position.

---

# 7

## Functional Descriptions

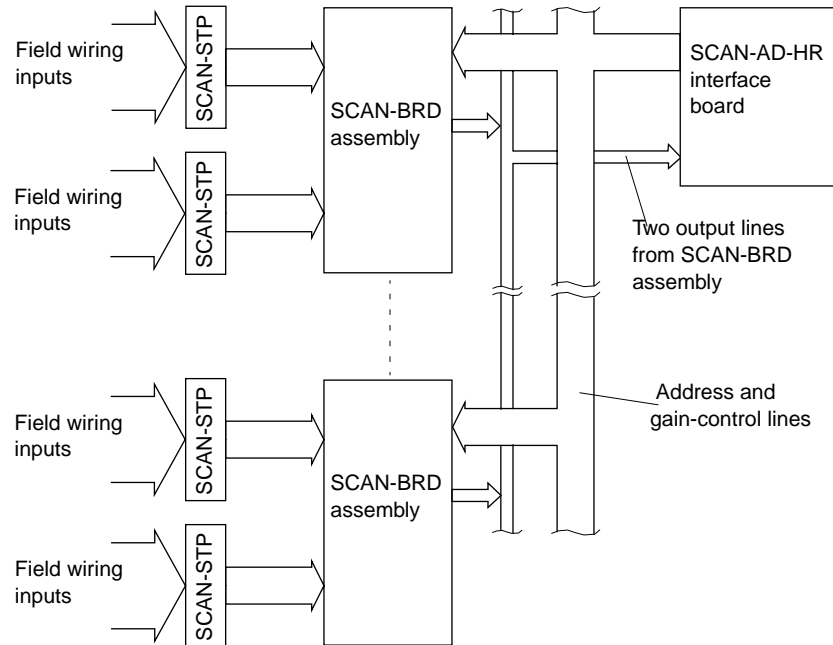
This chapter describes the following:

- DAS-Scan system
- SCAN-STP screw terminal panels
- SCAN-BRD-TC/TC-ISO assembly
- SCAN-BRD-V/V-ISO assembly
- SCAN-AD-HR interface board

### **DAS-Scan System**

---

Figure 7-1 shows a block diagram of the DAS-Scan system.



**Figure 7-1. Block Diagram of the DAS-Scan System**

You can wire up to 32 pairs of wires to the input terminals of each SCAN-STP screw terminal panel from voltage, current, or thermocouple inputs. The analog signals from the input pairs of two SCAN-STPs are cabled directly to the input channels of a SCAN-BRD assembly. SCAN-STP #0 connects to the 32 input channels of the base board, while SCAN-STP #1 connects to the 32 input channels of the mezzanine board.

When a SCAN-BRD assembly is addressed by the SCAN-AD-HR interface board, the SCAN-BRD multiplexes the 64 analog input signals into a single analog output signal and sends the signal to the input of the SCAN-AD-HR. The SCAN-AD-HR then converts the multiplexed analog signal into digital data that can be stored for analysis and/or control.

Address and gain-control codes for the SCAN-BRD assemblies come from a QRAM circuit on the SCAN-AD-HR. The QRAM circuit sends each address code over 12 address lines and each gain-control code over three gain control lines. Each address signal selects a SCAN-BRD assembly and then selects a channel on that assembly. At the same time, the gain-control signal sets the gain of the instrumentation amplifier on that assembly. Table 7-1 shows the gains and corresponding voltage ranges for a DAS-Scan system.

**Table 7-1. Gains and Ranges for a DAS-Scan System**

<b>Gain</b>	<b>Unipolar Range</b>	<b>Bipolar Range</b>
1	0 to +10.0 V	±10 V
2	0 to +5.0 V	±5.0 V
4	0 to 2.5 V	± 2.5 V
8	0 to 1.25 V	±1.25 V
50	0 to 0.2 V	±0.2 V
100	0 to 0.1 V	±0.1 V
200	0 to 50 mV	±50 mV
400	0 to 25 mV	±25 mV

A DAS-Scan system can process analog signals from up to 4,096 separate sources. Therefore, the system can operate with up to 128 SCAN-STP screw terminal panels and up to 64 SCAN-BRD assemblies.

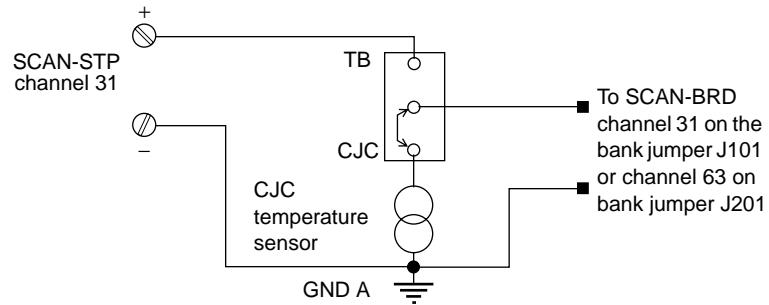
## **SCAN-STP Screw Terminal Panel**

---

The SCAN-STP-I is a screw terminal panel that can accept up to 32 single-ended wires from current output devices.

The SCAN-STP-V and SCAN-STP-TC are screw terminal panels that can accept up to 32 pairs of wires from field sensors. Channels 0 to 30 are floating for use as differential inputs; the negative side of channel 31 is tied to analog power ground.

The SCAN-STP-TC also contains CJC circuitry that you can enable by setting a single jumper across pins 31 and 32 of jumper block J101 (on the base board) or jumper block J201 (on the mezzanine board) of the attached SCAN-BRD-TC/TC-ISO. Figure 7-2 illustrates the CJC circuitry.

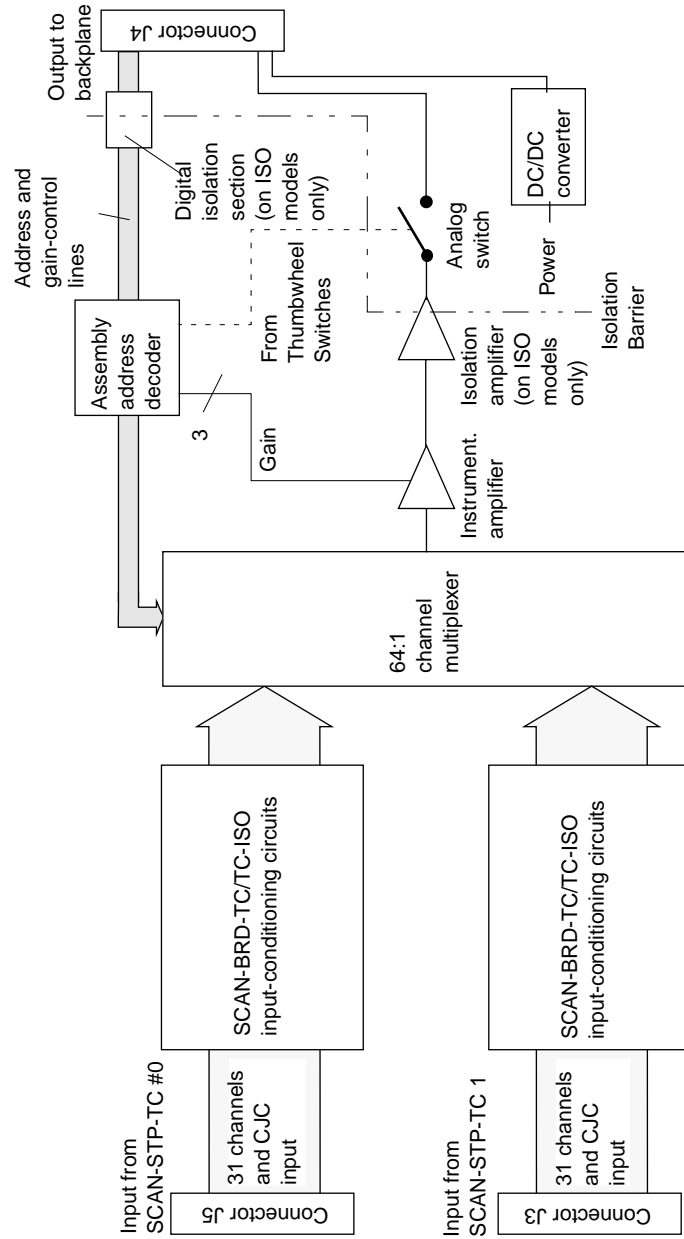


**Figure 7-2. CJC Circuitry**

## **SCAN-BRD-TC/TC-ISO Assembly**

---

Figure 7-3 is a block diagram of a SCAN-BRD-TC/TC-ISO assembly.

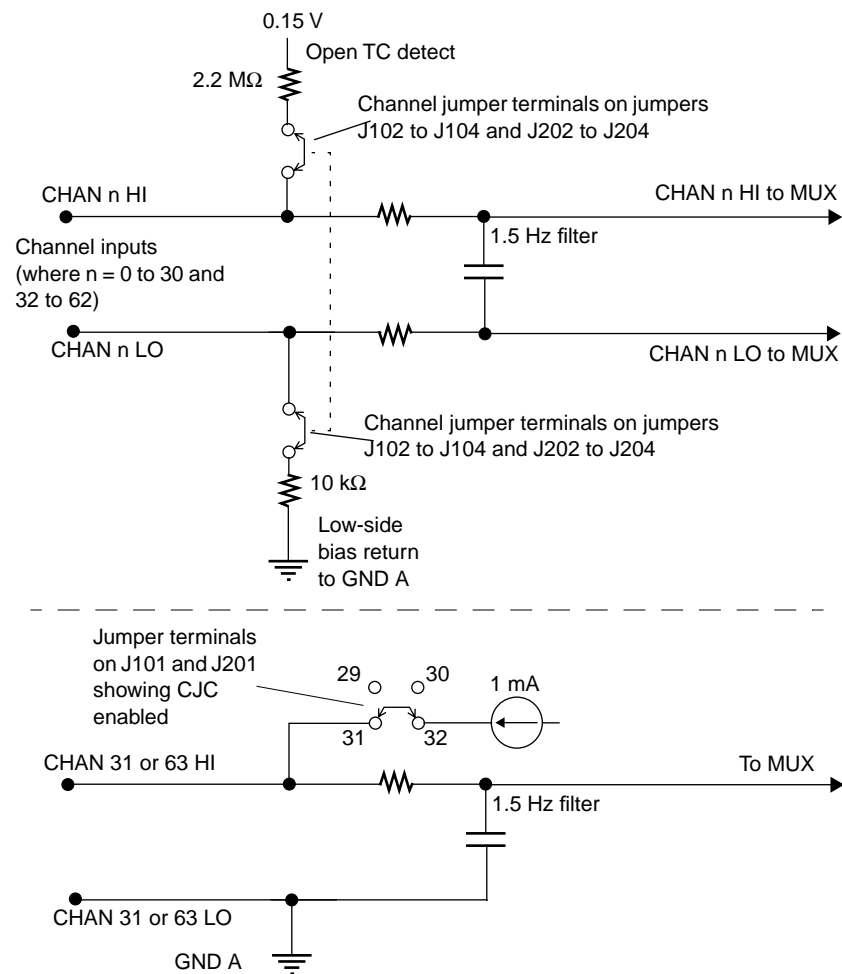


**Figure 7-3. Block Diagram of SCAN-BRD-TC/TC-ISO**



## Input-Conditioning Circuits

Each input channel of a SCAN-BRD-TC/TC-ISO assembly contains the input-conditioning circuitry shown in Figure 7-4.



**Figure 7-4. Input-Conditioning Circuitry**

Note that the open thermocouple detect and the low-side bias return circuits are options controlled by the two ganged jumpers. These jumpers are a part of the bank-jumpering system on the base and mezzanine boards of the SCAN-BRD-TC/TC-ISO assembly. Descriptions of the individual conditioning circuits are as follows:

- **Filter** - An 1.5 Hz low-pass filter that is permanently enabled.
- **Open thermocouple detection** - Composed of 2.2 M $\Omega$  and 10 k $\Omega$  resistors and enabled by ganged jumpers. This feature is available only on channels 0 to 30 and 32 to 62.
- **Low-side bias return** - Provides a reference to analog power ground (GND A) through a 10 k $\Omega$  resistor for ungrounded differential inputs. The 10 k $\Omega$  resistor provides some isolation from other channels, increases noise immunity and prevents current loops between thermocouples, and is a part of the open thermocouple detection circuit. This feature is enabled by a jumper and is available only on channels 0 to 30 and 32 to 62.
- **1 mA CJC supply** - Current source for the temperature sensor on the SCAN-STP-TC screw terminal panel. This feature is enabled by a jumper and is available only on channels 31 and 63.
- **GND A Return** - Provides a direct connection to analog signal ground and is present at all times on the low side of channels 31 and 63 only.

## Multiplexer

The sequence of channel sampling in the multiplexer is controlled by address lines from the QRAM output of the SCAN-AD-HR interface board. You set up the multiplexer channel-sampling sequence in the SCAN-AD-HR's channel-gain queue (in the QRAM circuit) using software.

## Instrumentation Amplifier

The multiplexer output feeds to an instrumentation amplifier with a software-selectable gain of 1, 2, 4, 8, 50, 100, 200, 400 (gains of 100, 200, and 400 are the most practical for use with thermocouples used with the DAS-Scan system). The instrumentation amplifier gain is selected by the gain-control lines from the SCAN-AD-HR interface board.

## Address Decoder

Twelve address lines carry the SCAN-BRD addresses. Six of the lines carry the SCAN-BRD address and are decoded according to the settings of the thumbwheel switches to close the analog switch. The other six lines carry channel addresses that sequence the channel sampling in the multiplexer.

## SCAN-BRD-V/V-ISO Assembly

Figure 7-5 shows a block diagram of a SCAN-BRD-V/V-ISO assembly.

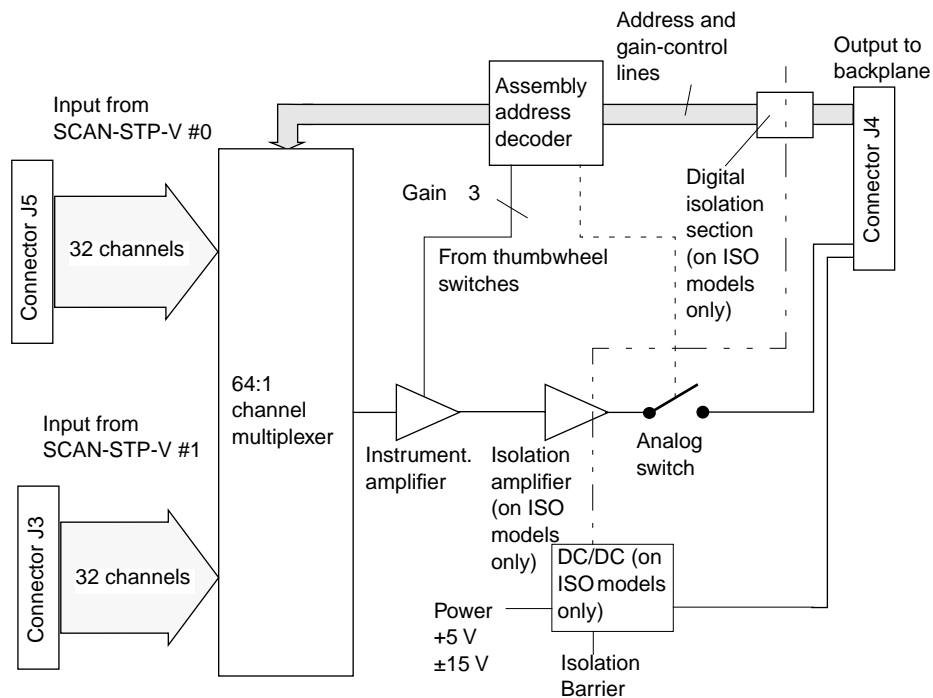


Figure 7-5. Block Diagram of SCAN-BRD-V/V-ISO

## Multiplexer

The sequence of channel sampling in the multiplexer is controlled by address lines from the QRAM output of the SCAN-AD-HR interface board. You set up the multiplexer channel-sampling sequence in the SCAN-AD-HR's channel-gain queue (in the QRAM circuit) using software.

## Instrumentation Amplifier

The multiplexer output feeds to an instrumentation amplifier with a software-selectable gain of 1, 2, 4, 8, 50, 100, 200, 400. The instrumentation amplifier gain is selected by the gain-control lines from the SCAN-AD-HR interface board.

## Address Decoder

Twelve address lines carry the SCAN-BRD addresses. Six of the lines carry the SCAN-BRD address and are decoded according to the address settings of the thumbwheel switches to close the analog switch. The other six lines carry channel addresses that sequence the channel sampling in the multiplexer.

## SCAN-AD-HR Interface Board

---

Figure 7-6 shows a block diagram of the SCAN-AD-HR interface board.

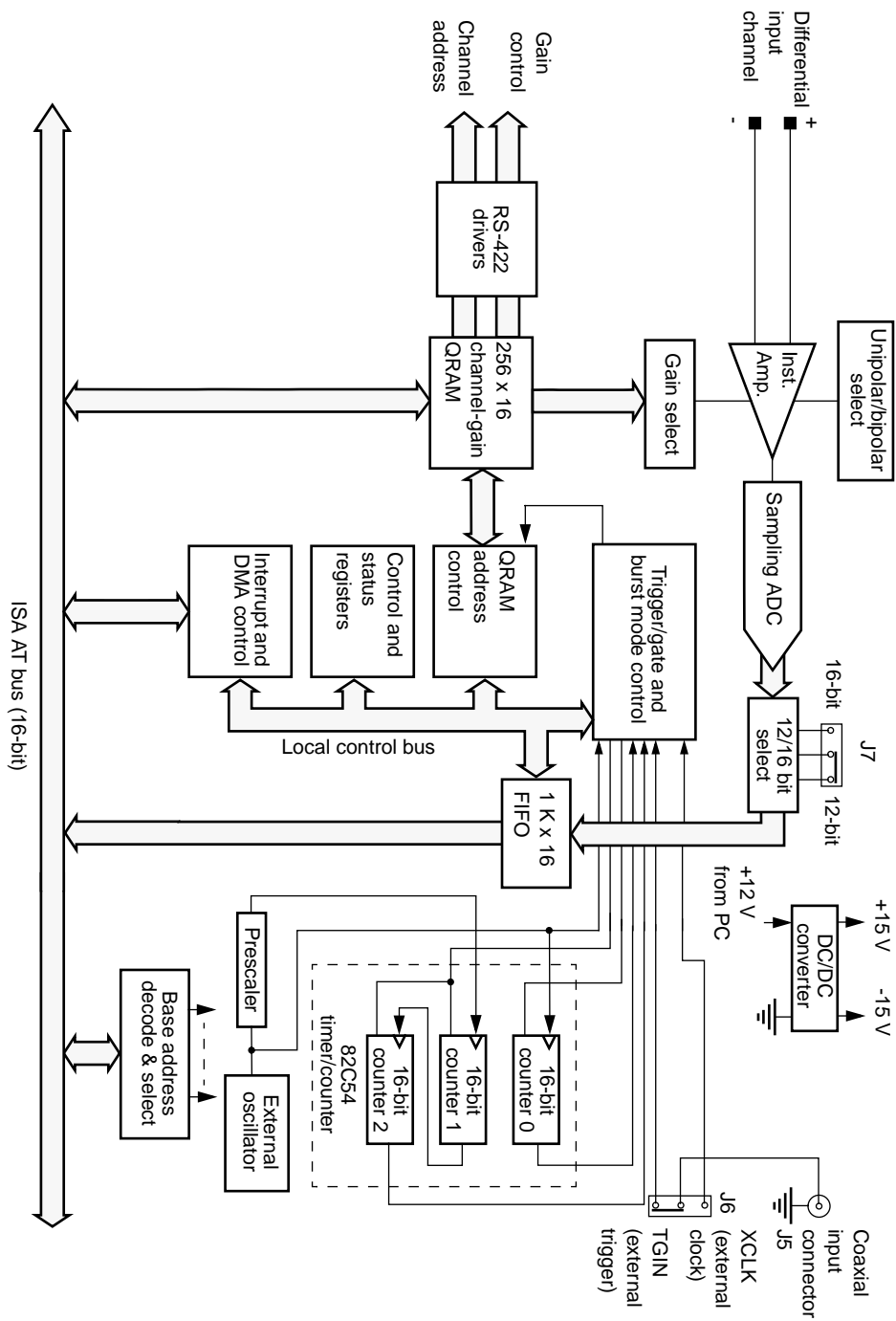


Figure 7-6. Block Diagram of SCAN-AD-HR Interface Board

## Unipolar/Bipolar Selection

Through software, you can set the SCAN-AD-HR interface board to operate in either the unipolar or bipolar input mode. A unipolar signal is always positive (0 to 5 V, for example), while a bipolar signal can swing up and down between positive and negative peak values ( $\pm 5$  V, for example).

A SCAN-AD-HR uses positive magnitude to represent unipolar input signals and two's complement for bipolar input signals. In a given input range with the same peak-voltage capacity for both modes, the unipolar mode improves the converter's resolution.

## Channel Sequencing and Gain Control

The SCAN-AD-HR interface board uses a  $256 \times 16$  QRAM storage circuit to serve as a channel-gain queue for controlling channel sequencing and gain of the SCAN-BRD assemblies. Each of the 256 queue positions holds a channel number and a corresponding gain that you provide through software. You can specify the channels sequentially or nonsequentially and with the same or different gains. You can also specify the same channel two or more times to improve the accuracy of the readings.

Twelve address lines select both the assembly address and channel sequencing for a SCAN-BRD assembly. These lines carry the channel-addressing information from the channel-gain QRAM through the main I/O connector of the SCAN-AD-HR. On the SCAN-BRD assembly, the assembly address is decoded according to the settings of the thumbwheel switches to control the analog switch; channel address lines go to the multiplexer.

Three gain-control lines set the gain of the instrumentation amplifier of a SCAN-BRD assembly while the channels are being sequenced in the multiplexer. Available gains for the instrumentation amplifier are 1, 2, 4, 8, 50, 100, 200, and 400.

## Maximum Achievable Throughput Rates

Because you can change input ranges on a per-channel basis, throughput must drop if you group channels with varying gains in sequence. The drop occurs because the channels with high gains (above 50) are slower than those with low gains and because the channels with low-level inputs must drive out the residual signals left by the high-level inputs, requiring longer settling time. The best way to maximize throughput is to use a combination of appropriate channel grouping and external signal conditioning. When using the channel-gain queue, consider the following suggestions:

- Keep all channels configured for a particular range together, even if you have to arrange the channels out of sequence.
- If your application requires high-speed scanning of low-level signals, use external signal conditioning to amplify the signal to  $\pm 10$  V or 0 to 10 V. This method offers the advantages of increasing total system throughput and reducing noise.
- If you are not using all the channels, you can make a particular channel-gain entry twice to allow for settling time. In this case, you want to ignore the results of the first entry.
- If you are measuring steady-state signals, do not use the channel-gain queue. Instead, use your program to step through the channels and perform single-channel acquisitions. For example, using software-controlled single-channel acquisitions to acquire 1000 samples on channel 0 at a gain of 1 and then 2000 samples on channel 1 at a gain of 200 virtually eliminates interference. This method is best for measuring steady-state signals even if all the channels are at the same gain.

Throughputs are based on driving the input with an ideal voltage source. The output impedance and drive of the source are far more critical when making large gain changes between two channels whose inputs are at the opposite extremes of their input ranges, as when a signal near  $-20$  mV is measured after a signal at near  $+5$  V. You will get better performance driving adjacent channels at the same gain. The source needs to be able to drive the input filter, the capacitance of the cable, and the multiplexer resistance and output capacitance. The multiplexer typically has about  $800 \Omega$  ( $1.6 \text{ k}\Omega$  maximum) in series with  $70 \text{ pF}$  output capacitance.

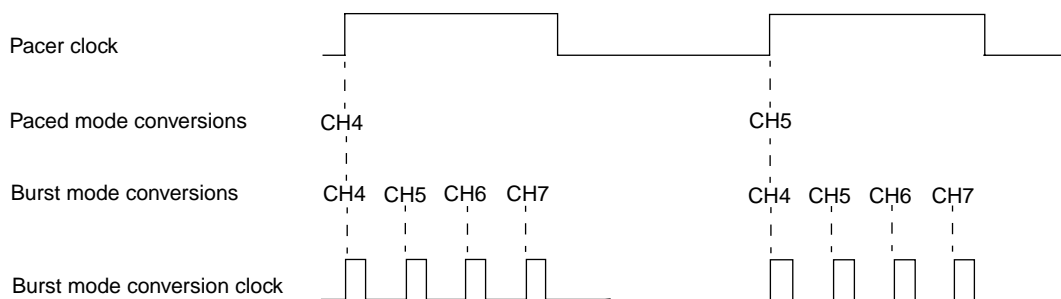
The maximum throughput for single-channel operation is 100 ksamples/s at a gain of 1, 2, 4, or 8. This throughput applies for operation in unipolar or bipolar mode.

## Conversion Modes

The conversion mode determines how the board regulates the timing of conversions when you are acquiring multiple samples from a single channel or from a queue of multiple channels. Through software, you can specify paced mode or burst mode, as follows:

- **Paced mode** - Paced mode is best-suited for continuous scanning of a queue of channels at a constant rate. In paced mode, the conversion rate equals the pacer clock rate. The sample rate, which is the rate at which a single channel is sampled, is the pacer clock rate divided by the number of channels in the queue. You can use paced mode with both isolated and nonisolated SCAN-BRD assemblies.
- **Burst mode** - In burst mode, each pulse from the pacer clock starts a scan of an entire queue of channels. The conversion rate during a burst mode scan is equal to the rate of the burst mode conversion clock. The sample rate, which is the rate at which a single channel is sampled, is equal to the pacer clock rate. You can use burst mode with nonisolated SCAN-BRD assemblies only.

Figure 7-7 shows the timing relationships of the paced and burst modes for a queue of channel 4 to channel 7.



**Figure 7-7. Conversion Modes**



## Clock Sources

The SCAN-AD-HR interface board provides two clocks: a pacer clock and a burst mode conversion clock. In paced mode, you use only a pacer clock, as shown in Figure 7-7 on page 7-13. In burst mode, you use both a pacer clock and the burst mode conversion clock, as shown in Figure 7-7 on page 7-13. These clock sources are described in the following sections.

### *Pacer Clock*

In paced mode, the pacer clock determines the period between the conversion of one channel and the conversion of the next channel. In burst mode, the pacer clock determines the period between the conversions of one queue of channels and the conversions of the next queue of channels. Through software, you select either the internal A/D pacer clock or an external pacer clock, as follows:

- **Internal pacer clock** - The internal pacer clock uses two cascaded counters of the onboard 82C54 counter/timer and a crystal-controlled 5 MHz time base. The maximum allowable rate is 100 kHz; the minimum available rate is 0.0012 Hz.
- **External pacer clock** - The external pacer clock is an externally applied TTL-compatible signal attached to coaxial input connector J5 (jumper J6 must be set to XCLK). The polarity (active edge) of the external pacer clock is software-selectable.

An external clock source is useful if you want to pace at rates not available with the 82C54 counter/timer, if you want to pace at uneven intervals, or if you want to pace on the basis of an external event.

---

**Note:** The ADC (analog-to-digital converter) acquires samples at a maximum of 100 ksamples/s (one sample every 10  $\mu$ s). Do not set an external pacer clock to pace conversions at a faster rate than the ADC can handle.

---

The maximum sampling rate for each channel is equal to the maximum allowable conversion rate divided by the number of channels used.

## ***Burst Mode Conversion Clock***

In burst mode, the burst mode conversion clock determines the period between the conversion of one channel in a queue and the conversion of the next channel in the queue. (The burst mode conversion clock is not used for paced mode.)

The burst mode conversion clock rate is software-selectable. The maximum rate is 100 kHz (10  $\mu$ s between conversions); the minimum rate is 15.625 kHz (64  $\mu$ s between conversions).

The sample rate (the rate at which a single channel is sampled) should be no more than the burst mode conversion clock rate divided by the number of channels in the queue.

## **Triggers**

A trigger is an event that occurs based on a specified set of conditions. An operation must have a start trigger to determine when acquisitions start. In addition, you can use an optional second trigger, the about trigger, to determine when acquisitions stop.

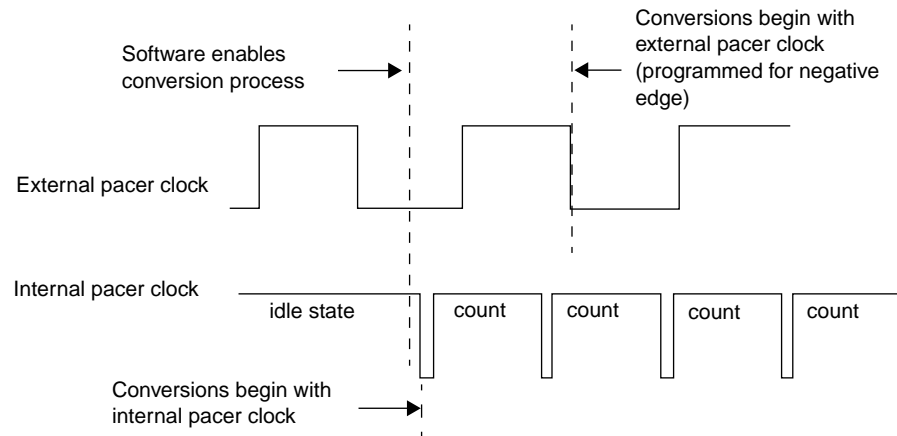
The start trigger can be an internal (software) trigger or an external digital trigger. The about trigger, if used, is always an external digital trigger. The trigger sources are described as follows:

- **Internal trigger** - When you enable the analog input operation, conversions begin immediately.
- **External digital trigger** - Connect an external digital trigger to coaxial input connector J5 (jumper J6 must be set to TGIN). The trigger signal is TTL-compatible and the polarity (active edge) is software-selectable, as follows:
  - *Positive-edge trigger* - The trigger event occurs on the rising edge of the trigger signal.
  - *Negative-edge trigger* - The trigger event occurs on the falling edge of the trigger signal.

The point at which conversions begin depends on the pacer clock, as follows:

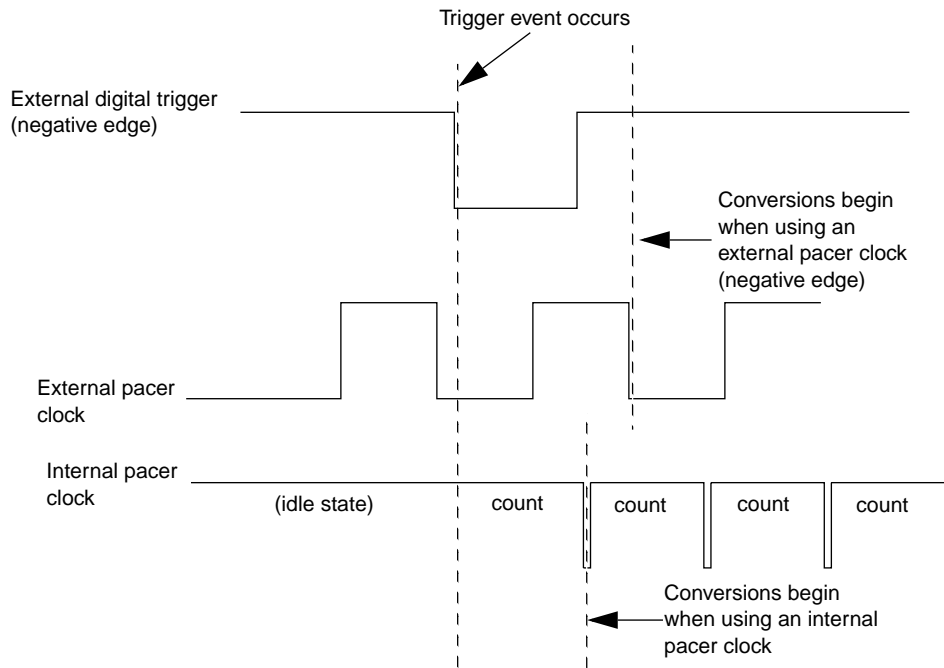
- **Internal pacer clock** - The 82C54 counter/timer is idle until the trigger event occurs. Within 400 ns, the first conversion begins. Subsequent conversions are synchronized to the internal pacer clock.
- **External pacer clock** - Conversions are armed when the trigger event occurs; conversions begin with the next active edge of the external pacer clock source and continue with subsequent active edges.

Figure 7-8 illustrates how conversions are initiated when using a software trigger. The point at which the software enables the conversion process represents the point at which the computer issues a write to allow conversions. The delay shown between that point and the start of the internal pacer clock is less than 1  $\mu$ s.



**Figure 7-8. Initiating Conversions with a Software Trigger**

Figure 7-9 illustrates how conversions are initiated when using an external digital trigger.



**Figure 7-9. Initiating Conversions with an External Digital Trigger**

If you use an about trigger, the operation stops when a specified number of samples has been acquired after the about-trigger event occurs. As described in the following sections, the about trigger allows you to acquire data before a trigger event (pre-trigger acquisition) or about (before and after) a trigger event (about-trigger acquisition). A start trigger alone allows you to acquire data after a trigger event (post-trigger acquisition).

### ***Pre-Trigger Acquisition***

In pre-trigger acquisition, you acquire data before a specific external digital trigger event. You specify a start trigger and an about trigger. The start trigger determines when the operation starts. The operation stops when the about-trigger event occurs. Pre-trigger acquisition is available only when you use the DMA resources of the board.

## ***About-Trigger Acquisition***

In about-trigger acquisition, you acquire data both before and after a specific external digital trigger event. You specify a start trigger and an about trigger. The start trigger determines when the operation starts. The operation stops after a specified number of samples has been acquired after the about-trigger event occurs. About-trigger acquisition is available only when you use the DMA resources of the board.

## ***Post-Trigger Acquisition***

In post-trigger acquisition, you acquire data after a specific event. You specify a start trigger to determine when the operation starts. The operation stops either when the specified number of samples has been acquired or through a software command.

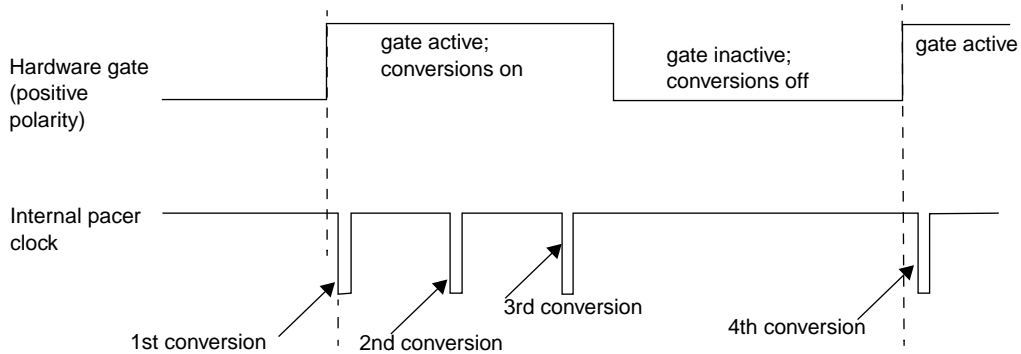
## **Hardware Gate**

A hardware gate is an externally applied digital signal that determines whether conversions occur. You apply a TTL-compatible hardware gate signal to coaxial connector J5 (jumper J6 must be set to TGIN).

You specify the polarity of the hardware gate through software. If you specify a positive gate, conversions occur only if the signal to TGIN is high; if the signal to TGIN is low, conversions are inhibited. If you specify a negative gate, conversions occur only if the signal to TGIN is low; if the signal to TGIN is high, conversions are inhibited.

You can use a hardware gate with an internal pacer clock only. The 82C54 counter/timer stops counting when the gate signal goes inactive. When the gate signal goes active, the 82C54 is reloaded with its initial count value and starts counting again; therefore, conversions are synchronized to the gate signal.

Figure 7-10 illustrates the use of the hardware gate with an internal pacer clock.



**Figure 7-10. Hardware Gate**

## Data Transfer

The SCAN-AD-HR board contains a 1024-word FIFO. The result of each conversion is automatically stored in the FIFO. You can transfer data from the FIFO to computer memory using either interrupts or the DMA resources of the board, as follows:

- **Interrupts** - You can program the board to generate an interrupt anytime the FIFO contains data (FIFO Not Empty) or after the FIFO accumulates 512 samples (FIFO Half Full). An interrupt service routine can then transfer data from the FIFO to computer memory while the FIFO continues to fill.

The interrupt level (3, 5, 7, 10, 11, or 15) is software-selectable.

Unpredictable interrupt latencies in Windows can make maximum board speeds unachievable; therefore, it is recommended that you use single-channel or dual-channel DMA instead of interrupts, if possible.

- **DMA resources** - You can use the DMA controller to bypass the CPU and transfer data directly from the SCAN-AD-HR board to computer memory. The ability to run independent of the CPU and at high-transfer rates makes DMA an attractive method for transferring data in data acquisition systems.

The SCAN-AD-HR board uses DMA channel 5, 6, or 7 to perform single-channel DMA transfers or DMA channel pairs 5 and 6, 6 and 7, or 7 and 5 to perform dual-channel DMA transfers. The DMA channel(s) are software-selectable.

Each DMA channel can transfer up to 65,536 samples before it has to be reprogrammed with a new memory address. When more than 65,536 samples are required by an application, the FIFO automatically stores the samples while the DMA channel is being reprogrammed for another address. In most situations, the FIFO allows you to acquire large amounts of gap-free data into multiple buffers at up to maximum board speed using a single DMA channel. However, if possible, you should use dual-channel DMA to acquire data reliably at maximum board speeds.

# A

## Specifications

Table A-1 contains specifications for the DAS-Scan system.

**Table A-1. Specifications for DAS-Scan System**

<b>Feature</b>	<b>Attribute</b>	<b>Specification</b>
Channels	Number	4,096 maximum
SCAN-STP screw terminal panels	Input channels	SCAN-STP-V: 31 differential + 1 single-ended inputs SCAN-STP-I: 32 single-ended inputs SCAN-STP-TC: 31 differential inputs
	Dimensions	SCAN-STP-V/SCAN-STP-I: 8.0 x 2.5 x 3.1 inches (203.2 x 63.5 x 78.7 mm)  SCAN-STP-TC: 8.625 x 3.0 x 4.375 inches (219.1 x 76.2 x 111.1 mm)
	CJC output	Channel 31 (SCAN-STP-TC only)
	Screw terminal wire size	12 gauge maximum
	Mounting	DIN rail
	Cable to SCAN-BRD assemblies	64-conductor, twisted-pair, ribbon cable (SCAN-CAB-64)



**Table A-1. Specifications for DAS-Scan System (cont.)**

<b>Feature</b>	<b>Attribute</b>	<b>Specification</b>
SCAN-BRD assemblies	Number in DAS-Scan system	64 maximum
	Number of channels	62 differential, 2 single-ended
	Gains	1, 2, 4, 8, 50, 100, 200, and 400 (software-selectable using 256-position channel-gain queue)
	Allowable input	±22 V maximum
	Isolation (SCAN-BRD-V-ISO and SCAN-BRD-TC-ISO only)	Type: board isolation  I/O voltage: 500 V <sub>rms</sub> continuous (no damage)  Measurement error (referred to input): (2 μV ÷ V) x (1 ÷ Gain)
	Input impedance	10 GΩ typical (channel on)
	CMRR (Common-mode rejection ratio)	85 dB, DC 82 dB @ 700 Hz, AC
	Dimensions	9.45 x 6.69 x 1.14 inches (240 x 170 x 29 mm)
	Field wiring	Through screw terminal panels that mount on DIN rails
	Power requirements	<p>SCAN-BRD-V and SCAN-BRD-TC:</p> <p>+5 V @ 390 mA typical, 500 mA maximum +15 V @ 22 A typical, 30 mA maximum -15 V @ 18 mA typical, 30 mA maximum</p> <p>SCAN-BRD-V-ISO and SCAN-BRD-TC-ISO:</p> <p>+5 V @ 550 mA typical, 660 mA maximum +15 V @ 30 mA typical, 36 mA maximum -15 V @ 30 mA typical, 36 mA maximum</p>

**Table A-1. Specifications for DAS-Scan System (cont.)**

<b>Feature</b>	<b>Attribute</b>	<b>Specification</b>
SCAN-CH chassis	Number	5 full-size or half-size chassis in a daisy chain maximum
	Number of slots	SCAN-CH-HALF: 7 SCAN-CH-FULL: 14
	Channel capacity	SCAN-CH-HALF: 448 SCAN-CH-FULL: 896
	Form factor	6U x 6HP shielded Eurocard enclosure
	Dimensions	SCAN-CH-HALF: 10.5 x 11.0 x 10.6 inches (266.7 x 294.6 x 269.2 mm)  SCAN-CH-FULL: 10.5 x 11.0 x 19.0 inches (266.7 x 294.6 x 482.6 mm)
	Mounting	SCAN-CH-HALF: Standard 19-inch rack using the SCAN-ADAPTER-HALF  SCAN-CH-FULL: Standard 19-inch rack
	DC power capacity	SCAN-CH-HALF: +5 V $\pm$ 5% @ 5.5 mA maximum +15 V $\pm$ 5% @ 2 A maximum -15 V $\pm$ 5% @ 0.5 A maximum  SCAN-CH-FULL: +5 V $\pm$ 5% @ 11 A maximum +15 V $\pm$ 5% @ 4 A maximum -15 V $\pm$ 5% @ 4 A maximum
	AC power	AC input: 90 to 264 Vrms  Input frequency: 47 to 63 Hz  SCAN-CH-HALF: Input current: 0.9 Arms Fuses: T3.15AL, 5 x 20 mm  SCAN-CH-FULL: Input current: 1.8 Arms Fuses: T6.3AL, 5 x 20 mm

**Table A-1. Specifications for DAS-Scan System (cont.)**

Feature	Attribute	Specification
Cables	Cable length	Performance as specified: 3.5 feet maximum (total daisy chain) <sup>1</sup>  CE-compliant configuration: 3 m maximum (any individual cable) 8 m maximum (total daisy chain)
SCAN-AD-HR board	A/D resolution	12 bits
	Input range	±10 V or 0 to 10 V maximum
	DMA channels	5, 6, 7, 5 + 6, 5 + 7, or 6 + 7 (software-selectable)
	Interrupt levels	3, 5, 7, 10, 11, or 15 (software-selectable)
	Pacer clock	Source: Internal or external through an SMA connector  Range: 0.0012 Hz to 100 kHz  External pulse width: 10 ns minimum  Level: LSTTL compatible
System throughput	≤ 256 channels concurrent	Nonisolated: 100 kHz (gains of 1, 2, 4, 8) 70 kHz (gains of 50, 100, 200, 400) 20 kHz (mixed gains)  Isolated (all gains): 3 kHz
	> 256 channels concurrent <sup>2,3</sup>	Nonisolated: 30 kHz (gains of 1, 2, 4, 8) 20 kHz (gains of 50, 100, 200, 400) 12 kHz (mixed gains)  Isolated (all gains): 2.5 kHz

**Table A-1. Specifications for DAS-Scan System (cont.)**

<b>Feature</b>	<b>Attribute</b>	<b>Specification</b>
Voltage measurement <sup>4</sup>	Accuracy (at full scale, bipolar input range) <sup>5</sup>	Gain of 1: 5.7 mV Gain of 2: 2.8 mV Gain of 4: 1.4 mV Gain of 8: 718 $\mu$ V Gain of 50: 261 $\mu$ V Gain of 100: 183 $\mu$ V Gain of 200: 107 $\mu$ V Gain of 400: 63.2 $\mu$ V
	Resolution (12-bit, bipolar input range)	Gain of 1: 4.88 mV Gain of 2: 2.44 mV Gain of 4: 1.22 mV Gain of 8: 610 $\mu$ V Gain of 50: 97.6 $\mu$ V Gain of 100: 48.8 $\mu$ V Gain of 200: 24.4 $\mu$ V Gain of 400: 12.2 $\mu$ V
	Offset drift over temperature (accuracy change per $^{\circ}$ C change from calibration temperature)	Nonisolated: Gain of 1: 14 $\mu$ V/ $^{\circ}$ C Gain of 2: 13 $\mu$ V/ $^{\circ}$ C Gain of 4: 12 $\mu$ V/ $^{\circ}$ C Gain of 8: 12 $\mu$ V/ $^{\circ}$ C Gain of 50: 12 $\mu$ V/ $^{\circ}$ C Gain of 100: 12 $\mu$ V/ $^{\circ}$ C Gain of 200: 12 $\mu$ V/ $^{\circ}$ C Gain of 400: 12 $\mu$ V/ $^{\circ}$ C  Isolated: Gain of 1: 264 $\mu$ V/ $^{\circ}$ C Gain of 2: 138 $\mu$ V/ $^{\circ}$ C Gain of 4: 75 $\mu$ V/ $^{\circ}$ C Gain of 8: 43 $\mu$ V/ $^{\circ}$ C Gain of 50: 17 $\mu$ V/ $^{\circ}$ C Gain of 100: 15 $\mu$ V/ $^{\circ}$ C Gain of 200: 14 $\mu$ V/ $^{\circ}$ C Gain of 400: 13 $\mu$ V/ $^{\circ}$ C
	Channel bandwidth	SCAN-BRD-V: 40 kHz @ -3 dB minimum  SCAN-BRD-V-ISO: 3 kHz @ -3 dB minimum

**Table A-1. Specifications for DAS-Scan System (cont.)**

<b>Feature</b>	<b>Attribute</b>	<b>Specification</b>
Current measurement	Accuracy (at full scale) ±20 mA input range: 0 to 20 mA input range:	40 µA 20 µA
	Resolution (12-bit) Bipolar input range Unipolar input range	9.76 µA 4.88 µA
	Offset drift over temperature (accuracy change per °C change from calibration temperature)	Nonisolated: 26 nA/°C Isolated: 276 nA/°C
	Input resistance	250 Ω ± 0.1%
Thermocouple measurement	Measurement range (unipolar) Type J: Type K: Type T: Type E: Type S: Type R: Type B:	Gain of 200: 0 to 760°C <sup>6</sup> Gain of 400: 0 to 458°C Gain of 100: 0 to 1,372°C <sup>6</sup> Gain of 200: 0 to 1,232°C Gain of 400: 0 to 603°C Gain of 400: 0 to 400°C <sup>6</sup> Gain of 100: 0 to 1,000°C <sup>6</sup> Gain of 200: 0 to 662°C Gain of 400: 0 to 351°C Gain of 400: 0 to 1,768°C <sup>65</sup> Gain of 400: 0 to 1,768°C <sup>6</sup> Gain of 400: 40 to 1,820°C <sup>6</sup>

**Table A-1. Specifications for DAS-Scan System (cont.)**

Feature	Attribute	Specification
Thermocouple measurement (cont.)	Measurement range (bipolar) <sup>6</sup>	Type J: Gain of 200: -210 to 760°C Gain of 400: -210 to 458°C
		Type K: Gain of 100: -210 to 1,372°C Gain of 200: -210 to 1,232°C Gain of 400: -210 to 603°C
		Type T: Gain of 400: -270 to 400°C
		Type E: Gain of 100: -270 to 1,000°C Gain of 200: -270 to 662°C Gain of 400: -270 to 351°C
		Type S: Gain of 400: 0 to 1,768°C
		Type R: Gain of 400: 0 to 1,768°C
		Type B: Gain of 400: 40 to 1,820°C
	Measurement resolution (unipolar) <sup>6</sup>	Type J: Gain of 200: 0.2°C Gain of 400: 0.1°C
		Type K: Gain of 100: 0.6°C Gain of 200: 0.3°C Gain of 400: 0.2°C
		Type T: Gain of 400: 0.2°C
		Type E: Gain of 100: 0.4°C Gain of 200: 0.2°C Gain of 400: 0.1°C
		Type S: Gain of 400: 0.1°C
		Type R: Gain of 400: 1.1°C
		Type B: Gain of 400: 7.0°C

**Table A-1. Specifications for DAS-Scan System (cont.)**

Feature	Attribute	Specification	
Thermocouple measurement (cont.)	Measurement resolution (bipolar) <sup>6</sup>	Type J: Gain of 200: 0.5°C Gain of 400: 0.2°C	
		Type K: Gain of 100: 1.2°C Gain of 200: 0.6°C Gain of 400: 0.3°C	
		Type T: Gain of 400: 0.3°C	
		Type E: Gain of 100: 0.8°C Gain of 200: 0.4°C Gain of 400: 0.2°C	
		Type S: Gain of 400: 2.2°C	
		Type R: Gain of 400: 2.3°C	
		Type B: Gain of 400: 14.0°C	
		Accuracy <sup>5</sup>	Type J: Gain of 200: 1.3°C Gain of 400: 1.1°C
			Type K: Gain of 100: ±1.9°C Gain of 200: ±1.6°C Gain of 400: ±1.3°C
			Type T: Gain of 400: ±1.3°C
			Type E: Gain of 100: ±1.8°C Gain of 200: ±1.2°C Gain of 400: ±1.0°C
			Type S: Gain of 400: 6.3°C
			Type R: Gain of 400: 6.3°C
			Type B: Gain of 400: 7.6°C

**Table A-1. Specifications for DAS-Scan System (cont.)**

Feature	Attribute	Specification
Thermocouple measurement (cont.)	Offset drift	Type J: Gain of 200: 0.3°C/°C Gain of 400: 0.3°C/°C
		Type K: Gain of 100: 0.5°C/°C Gain of 200: 0.4°C/°C Gain of 400: 0.4°C/°C
		Type T: Gain of 400: 0.4°C/°C
		Type E: Gain of 100: 0.3°C/°C Gain of 200: 0.3°C/°C Gain of 400: 0.3°C/°C
		Type S: Gain of 400: 1.7°C/°C
		Type R: Gain of 400: 1.5°C/°C
		Type B: Gain of 400: 3.0°C/°C
	Bandwidth	1.5 Hz @ -3 dB
	Thermocouple linearization	Through software for the following thermocouple types: J, K, T, E, S, R, and B
	CJC	CJC sensor location: one per SCAN-STP-TC, thermally bonded beneath screw terminals  Measurement channels: 31 and 63  CJC circuit output: 2.730 V + 10.06 mV/°C  Dynamic nonuniformity: 4.3% of step change in temperature  Thermal time constant ( $\Delta 63\%$ ): 33 minutes (still air) 23 minutes (400 cubic feet/minute)



**Table A-1. Specifications for DAS-Scan System (cont.)**

Feature	Attribute	Specification
Thermocouple measurement (cont.)	Open thermocouple detection	Configuration: jumper-selectable in banks of eight channels  Indication: positive full-scale reading  Detection: through software
	Thermocouple limitations	Open thermocouple detect current: 45 nA  Maximum resistance: 135 Ω  Open thermocouple detect delay: 4.5 s
Computer interface	Slot	Single-slot, full-length
	Bus	AT, ISA bus
	Power requirements	+5 V @ 700 mA typical, 840 mA maximum  +12 V @ 200 mA typical, 240 mA maximum
Environmental	Operating temperature	0 to 50 °C
	Storage temperature	-40 to +85 °C
	Humidity	0 to 95% (noncondensing)
CE compliance	General	Self-certified, EMC directive 89/336/EEC
	Safety	Per EN60950 low voltage directive:
	Immunity per standard EN50082-1:1992	ESD per method IEC-801-1 @ 8 kV RF per method IEC801-3:1984 Surge per method IEC801-5:1988
	Emissions (standard EN55081-1:1992)	Radiated + conducted per method EN5022:1987 CISPR22:1993

**Notes**

<sup>1</sup> You can use longer cables; however, if you do, accuracy will be reduced. Refer to footnote #5 for information on determining the actual accuracy when using longer cables.

<sup>2</sup> For measurements made with the SCAN-BRD-TC or SCAN-BRD-TC-ISO, the effective per channel rate cannot exceed 10 Hz. Therefore, you should not sample a channel on a SCAN-BRD-TC or SCAN-BRD-TC-ISO assembly within 100 μs of the time that the channel was last sampled.

- <sup>3</sup> System throughputs for more than 256 channels are software and operating system dependent.
- <sup>4</sup> Applies to SCAN-BRD-V and SCAN-BRD-V-ISO assemblies and SCAN-BRD-TC/TC-ISO assemblies that are measuring voltage inputs.
- <sup>5</sup> Specified accuracy is typical accuracy at calibration temperature and includes all DAS-Scan system errors and noise. Use specified accuracy in conjunction with offset drift to calculate accuracy over a wider environmental temperature range. In addition, a total daisy-chain cable length of 3.5 feet is assumed; if you are using a 25-foot cable, multiply the resolution (in LSB) by 2.2 LSB and add as error to the specified accuracy; if you are using a 100-foot cable, multiply the resolution (in LSB) by 2.5 LSB and add as error to the specified accuracy.
- <sup>6</sup> Limited by thermocouple characteristics.

# B

## Keithley Memory Manager

The Keithley Memory Manager (KMM), which is shipped with the ASO software package, allows you to reserve a memory heap that is adequate for the needs of your application.

The reserved memory heap is part of the total physical memory available in your system. When your program requests memory, the memory buffer is allocated from the reserved memory heap instead of from the Windows global heap. The KMM is DAS product independent and can be used by multiple Keithley DAS Windows programs simultaneously. Also, the memory allocated with the KMM can be used by a DMA controller, if applicable.

The KMM includes the following files:

- **VDMAD.386** - Customized version of Microsoft's Virtual DMA Driver for Windows 3.1 or Windows for Workgroups 3.11. When you use the KMM to reserve a memory heap, Microsoft's Virtual DMA Driver is replaced by the VDMAD.386 file.
- **VDMAD.VXD** - Customized version of Microsoft's Virtual DMA Driver for Windows 95. When you use the KMM to reserve a memory heap, Microsoft's Virtual DMA Driver is replaced by the VDMAD.VXD file.

---

**Note:** If you have multiple versions of VDMAD.386 or VDMAD.VXD, you should install the latest version; to determine which version is the latest, refer to the time stamp of the file.

---

- **KMMSETUP.EXE** - Utility that helps you set up the KMM parameters and then modifies your Windows configuration files accordingly.

# Installing and Setting Up the KMM in Windows 3.1 and Windows for Workgroups 3.11

---

To install and set up the KMM whenever you start up Windows 3.1 or Windows for Workgroups 3.11, you must modify the SYSTEM.INI file. You can modify the SYSTEM.INI file using either the KMMSETUP.EXE program or a text editor.

## Using KMMSETUP.EXE

Use KMMSETUP.EXE to modify your Windows SYSTEM.INI file as follows:

1. Double-click the KMM icon in the DAS-Scan program group.  
The Keithley Memory Manager - Setup panel appears.
2. Specify the appropriate options. For more information, click **Help** on the panel.
3. Click **Update** to update the SYSTEM.INI file with the changes you have made.
4. If you changed the default value, click **Restart Windows** to ensure that the changes take effect immediately.

## Using a Text Editor

Use a text editor to modify the [386Enh] section of your SYSTEM.INI file as follows:

1. Replace the line `device=*vdmad` with the following statement:

```
device=c:\windows\vdmad.386
```

---

**Note:** Normally, the VDMAD.386 file is stored in the WINDOWS directory; if it is stored elsewhere, enter the correct path and name.

---

2. Add the following line:

```
KEIDMAHEAPSIZE=<size>
```

where *size* indicates the desired size of the reserved memory heap in KB.

---

**Notes:** The memory size you specify is no longer available to Windows. For example, if your computer has 8 MB of memory installed and you specify `KEIDMAHEAPSIZE=1000` (1 MB), Windows can only see and use 7 MB.

If you do not add the `KEIDMAHEAPSIZE` keyword or if the size you specify is less than 128, a 128 KB minimum heap size is assumed. The maximum heap size is limited only by the physical memory installed in your system and by Windows itself.

---

3. Restart Windows to ensure that the system changes take effect.

## **Installing and Setting Up the KMM in Windows 95**

---

To use `KMMSETUP.EXE` to modify your Windows 95 Registry and the `SYSTEM.INI` file, perform the following steps:

1. Point to **Programs, Keithley DAS-Scan, and Memory Manager Setup** on the **Start** menu.

The Keithley Memory Manager - Setup panel appears.

2. Specify the appropriate options. For more information, click **Help** on the panel.
3. Click **Update** to update the `SYSTEM.INI` file with the changes you have made.
4. If you changed the default value, click **Restart Windows** to ensure that the changes take effect immediately.

## Removing the KMM

---

If necessary, you can remove the updated information from the Windows configuration files and return all previously reserved memory to Windows.

If you are using KMMSETUP.EXE, click **Remove** to remove the updated information. If you are using a text editor (for Windows 3.1 or Windows for Workgroups 3.11 only), modify and/or delete the appropriate lines in SYSTEM.INI. In either case, you must restart Windows to ensure that the changes take effect.

# C

## Blank Channel Mapping Forms

This appendix provides blank channel-mapping forms for use as copy masters. You need two forms for each SCAN-BRD assembly: one for the base board and one for the mezzanine board.

### Channel Routing Map for Base Board

Chassis # \_\_\_\_\_ (Assign a number)

Chassis Slot # \_\_\_\_\_ (1 to 7 or 1 to 14)

SCAN-BRD Assembly Board Address \_\_\_\_\_ (00h to 3Fh)

SCAN-STP Panel #   0  

SCAN-STP Screw Terminal (0 to 31)	SCAN-BRD Channel # (0 to 31)	System Channel # (0 to 4095)	Sensor Tag (Assign a name or number)
0	0		
1	1		
2	2		
3	3		
4	4		
5	5		
6	6		
7	7		
8	8		
9	9		
10	10		
11	11		
12	12		
13	13		
14	14		
15	15		
16	16		
17	17		
18	18		
19	19		
20	20		
21	21		
22	22		
23	23		
24	24		
25	25		
26	26		
27	27		
28	28		
29	29		
30	30		
31	31		



### Channel Routing Map for Mezzanine Board

Chassis # \_\_\_\_\_ (Assign a number)

Chassis Slot # \_\_\_\_\_ (1 to 7 or 1 to 14)

SCAN-BRD Assembly Board Address \_\_\_\_\_ (00h to 3Fh)

SCAN-STP Panel # 1

SCAN-STP Screw Terminal (0 to 31)	SCAN-BRD Channel # (32 to 63)	System Channel # (0 to 4095)	Sensor Tag (Assign a name or number)
0	32		
1	33		
2	34		
3	35		
4	36		
4	37		
6	38		
7	39		
8	40		
9	41		
10	42		
11	43		
12	44		
13	45		
14	46		
15	47		
16	48		
17	49		
18	50		
19	51		
20	52		
21	53		
22	54		
23	55		
24	56		
25	57		
26	58		
27	59		
28	60		
29	61		
30	62		
31	63		

# D

## CE Information for the DAS-Scan System

---

**Note:** Products that contain the CE mark are certified to meet European EMC directive 89/336 EEC. If this directive is not of importance to your application, please disregard the information in this appendix.

---

Keithley MetraByte certifies that this product has been tested and found to be in compliance with the EMC directive and relevant harmonized standards. This appendix describes the limitation of certification, the declaration of conformity, and the cabling instructions required for the CE configuration.

### Limitation of Certification

---

This certification applies only to the operation of the product (with specified cables and accessories) in the stated configuration and under the stated operational and environmental specifications. Any modification, misuse, or improper or inadequate maintenance of the product by the user voids this certification.

Any deviation from the specific configuration may cause emissions or susceptibility not within the allowed limits required by the stated directive. It is the user's responsibility to demonstrate and maintain compliance with the directive and standards.

Please read the next section for the specific testing configuration for this product. Consult the Keithley Instruments GMBH office (European importer) or Technical Support in Taunton, MA, USA, for further information regarding the exact configuration details and testing.


## Declaration of Conformity

---

<b>Application of Council Directive(s)</b>	89/336/EEC
<b>Standard(s) to which Conformity is Declared</b>	EN50081-1, EN50082-1
<b>Manufacturer's Name</b>	Keithley MetraByte
<b>Importer's Name</b>	Keithley Instruments GMBH
<b>Importer's Address</b>	Landsberger Str.65 D-82110 Germering, Munich
<b>Type of Equipment</b>	Data Acquisition System
<b>Model Numbers</b>	SCAN-AD-HR board, S-1802/M cable, SCAN-CH chassis, S-1800/MM cable for multiple chassis
<b>Year of Manufacture</b>	1996

**I, the undersigned, hereby declare that the equipment specified above conforms to the above Directive(s) and Standard(s).**

**Place:** Taunton, MA USA

  
(Signature)

**Date:** 01 January 1996

Mark Urban  
(Name)

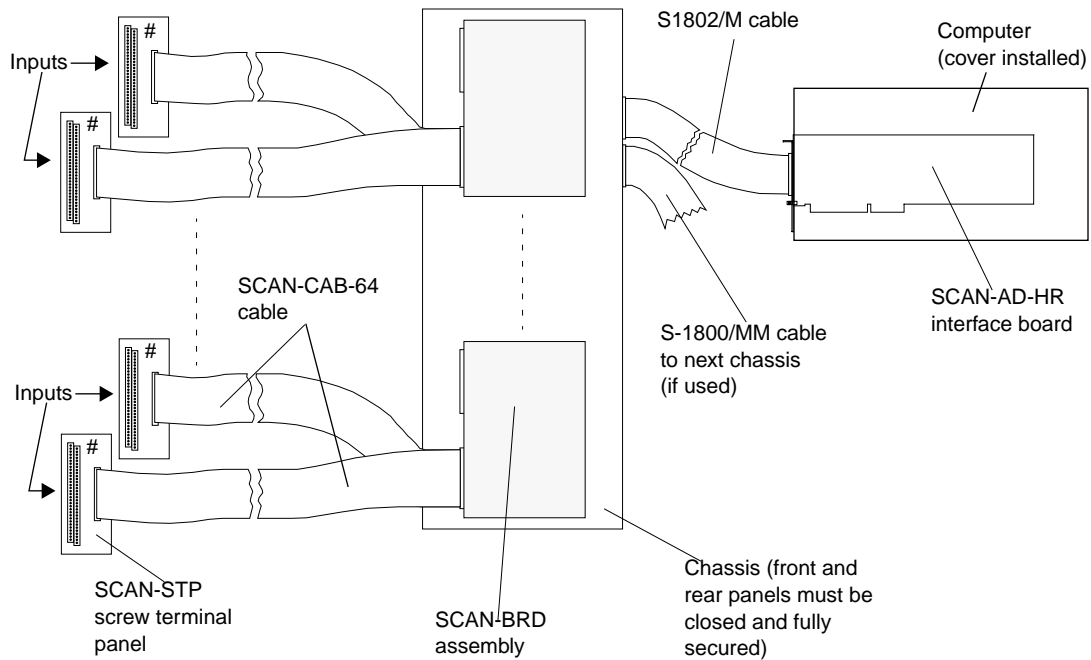
Quality Assurance Manager  
(Position)

## Requirements for CE Configuration

CE configuration requirements for a DAS-Scan system are as follows:

- The chassis-to-computer cable must be shielded; use an S-1802/M cable.
- Chassis-to-chassis cabling must be shielded; use an S-1800/MM cable.
- Chassis front and rear panels must be closed and fully secured.
- The computer cover must be installed.

Figure D-1 shows the CE configuration requirements.



**Figure D-1. CE Configuration for a DAS-Scan System**

# E

## Maximizing System Performance

This appendix provides additional information that can enhance the operation of your DAS-Scan system.

### Setting up a Scan of More than 256 Channels

The maximum channel capacity of a DAS-Scan system, with a full complement of 64 SCAN-BRD assemblies and 128 SCAN-STP screw terminal panels, is 4,096. Each SCAN-BRD assembly allows the system to scan up to 64 input channels. The QRAM (on the SCAN-AD-HR interface board), however, can store channel-gain information for only 256 input channels (four SCAN-BRD assemblies) at a time. To accommodate the 256-channel QRAM limit, the system configuration file is designed to address the SCAN-BRD assemblies in groups of four (for up to 256 input channels). A group of four SCAN-BRD assemblies is referred to as a "virtual board;" a configuration file can contain up to 16 virtual boards.

To set up a DAS-Scan system for scanning more than 256 channels, perform the following steps:

1. Create a configuration file for the SCAN-BRD assemblies in your system. (Refer to page 2-16.) Configure one virtual board for each set of four SCAN-BRD assemblies, assigning the SCAN-BRD assemblies to virtual boards as shown in Table 2-5 on page 2-18.
2. Set the assembly addresses on the thumbwheel switches of the SCAN-BRD assemblies to match.

3. Set up a software event timer to be used for the overall per-channel sample rate per channel (for example, 1 Hz).  
  
For Visual Basic, the event timer would be a timer control; for TestPoint, the event timer would be a time object. Each event from the event timer should trigger step 4 for virtual board 0.
4. Load the QRAM for virtual board 0 (the first group of 256 input channels).
5. Set the system clock rate to the maximum throughput specified in Appendix A for the SCAN-BRD assembly types and the gain you are using in this virtual board. (Note that if the gains are different, specify mixed.)
6. Start background A/D conversions, sampling each channel once. Make sure your software is configured to generate an event when conversions are complete.
7. Process the data.
8. Let the event signal for "conversions are complete" begin a repeat of steps 4 through 7 for each additional virtual board being scanned.

## Improving Accuracy

---

The DAS-Scan system's typical accuracy is specified at the calibrated temperature. If the temperature of the chassis changes measurably, zero drift of the amplifiers can cause offsets, resulting in measurement errors.

If measurements taken by your DAS-Scan system appear to be outside the specified accuracy of the DAS-Scan system, you can improve the accuracy in one of the following ways:

- Reserve one unused channel on each SCAN-BRD assembly. Then, short each of the unused channels and tie them to ground (ground is screw terminal 31 low (-) on any of the SCAN-STP screw terminal panels connected to the chassis).

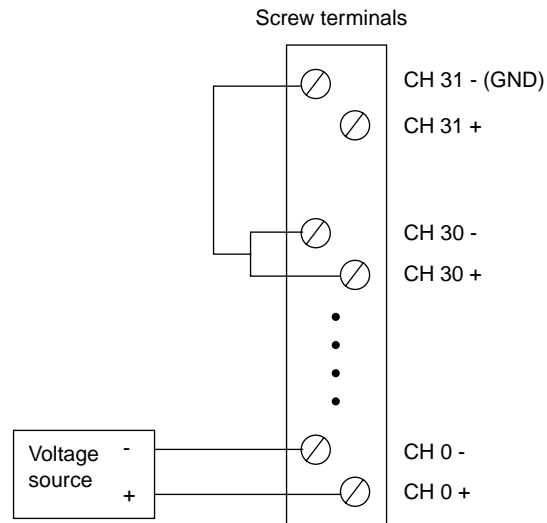
You can compensate for the zero drift on each assembly by using the assembly's shorted channel as a reference. For example, assume channel 30 on a SCAN-BRD assembly is shorted and tied to ground, and the reading on channel 30 is  $-30$  mV. The voltage you read is  $30$  mV less than the actual voltage (which should be  $0$  V). To determine the actual voltage on your measurement channels, add  $30$  mV to the voltages read on all the other channels on the SCAN-BRD assembly.

---

**Note:** Zero drift is also a function of gain. You should sample your shorted channel once at each of the gains you are using on that SCAN-BRD assembly. Then, when performing the software correction for each measurement channel, use the reference data for the appropriate gain.

---

Figure E-1 illustrates the use of channel 30 as a reference channel when measuring an input on channel 0.



**Figure E-1. Improving Accuracy**

- Recalibrate your DAS-Scan system. The factory calibration of the DAS-Scan system assumes that you will be operating your DAS-Scan system at 25°C (77°F). If your actual operating temperature is not 25°C, use the DAS-Scan Calibration Utility (CALSCAN.EXE) to recalibrate the DAS-Scan system at the actual operating temperature. Refer to Chapter 6 and to the online help of the calibration utility for information.

## Reducing the Effects of Power-Line Noise

---

If power-line noise is affecting the accuracy of your measurements, you can sample each of your channels at a multiple of the line frequency and then average the readings. For best results, you should sample each channel during a period of 1/60 of a second (in the United States and other places that use 60-cycle power) or during a period of 1/50 of a second (in Europe and other places that use 50-cycle power).

Use the following formula to determine the per channel sample rate (in Hertz):

$$\text{sample rate} = (\text{line frequency}) \times (\# \text{ of samples per channel})$$

Keep in mind that all sampling must be completed on the specified channel before sampling the next channel.

For example, for a 10-to-1 improvement at a line frequency of 50 Hz, use a sample rate of 500 Hz per channel (50 x 10). For a 100-to-1 improvement at a line frequency of 60 Hz, use a sample rate of 6000 Hz (60 x 100).

After you sample all your channels, average the data.



# Index

## Numerics

16-bit or 12-bit operation 2-10  
7BP16 backplane 1-7, 3-28  
82C54 counter/timer 7-14, 7-18

## A

A/D mode 2-18  
about trigger 7-15, 7-17  
about-trigger acquisition 7-18  
AC power 3-19  
AC1393 cable 1-7  
accessory  
    7BP16 backplane 1-7, 3-28  
    AC1393 cable 1-7  
    C-2600 cable 1-7  
    CAB-SMA-BNC cable 1-7, 3-28  
    DIN rail 1-2, 1-7, 3-2  
    insertion block 1-7, 3-3  
    MB01 backplane 1-7, 3-28  
    S-1802/MM cable 3-26  
    SCAN-ADAPTER-HALF 1-7, 3-10  
    SCAN-ADAPTER-MB adapter 1-7,  
        3-28  
    SCAN-MOUNT-PAIR 1-7, 3-11  
accuracy, improving E-2  
ADC 7-14  
address  
    assembly 2-12, 2-18  
    base I/O 2-8, 2-17  
    decoder 7-8, 7-9  
    lines 7-8, 7-9, 7-11  
amplifier, instrumentation 7-7, 7-9  
analog-to-digital converter 7-14  
ASO-SCAN software 1-5  
    installing 2-4

assembly 1-4, 2-10, 7-2  
    SCAN-BRD-TC 1-4, 7-4  
    SCAN-BRD-TC-ISO 1-4, 7-4  
    SCAN-BRD-V 1-4, 7-8  
    SCAN-BRD-V-ISO 1-4, 7-8  
assembly address 2-12, 2-18  
    configuring 2-12

## B

bank jumpers 2-14  
base I/O address 2-17  
    configuring 2-8  
    switch 2-8  
bias return 7-7  
bipolar input range 7-11  
    configuring 2-18  
block diagram  
    DAS-Scan system 7-2  
    SCAN-AD-HR 7-10  
    SCAN-BRD-TC/TC-ISO 7-5  
    SCAN-BRD-V/V-ISO 7-8  
board  
    SCAN-AD-HR 1-5, 2-8, 3-26, 7-9  
    virtual 2-16  
board-select LEDs 4-3  
bundle options 2-3  
burst mode 7-13  
burst mode conversion clock 7-13, 7-15

## C

C-2600 cable 1-7  
cable  
    AC1393 1-7  
    C-2600 1-7  
    CAB-SMA-BNC 1-7, 3-28  
    S-1802/M 1-5, 3-25, 3-26

- S-1802/MM 1-5, 3-26
- SCAN-CAB-64 1-4, 3-2
- CAB-SMA-BNC cable 1-7, 3-28
- calibration 6-1
  - configuring 2-10
  - equipment 6-1
  - utility 6-2
- CALSCAN.EXE utility 6-2
- CE information D-1
- certification, CE D-1
- CFGSCAN.EXE utility 1-6
- channels
  - channel-gain queue 7-7, 7-9, 7-11
  - channel-mapping form C-1
  - DMA 2-17, 7-20
  - input jumpers 2-13
  - logical 2-16
  - routing 3-1
  - sequencing 7-11
- chassis
  - connecting multiple 3-26
  - mounting 3-10
  - SCAN-CH-FULL 1-4
  - SCAN-CH-FULL/NO PWR 1-5
  - SCAN-CH-HALF 1-4
  - SCAN-CH-HALF/NO PWR 1-5
  - setting up internal power 3-19
- checking the power supply 3-22
- CJC
  - circuitry 7-4
  - enabling/disabling 2-15
  - input 2-15
  - supply 7-7
- clock 7-14
  - burst mode conversion 7-13, 7-15
  - pacer 7-13, 7-14
- clock input 2-9
  - connecting 3-28
- conditioning circuits 7-6
- configuration file 2-16
- configuration utility 1-6, 2-16

- configuring
  - an external clock/trigger/gate 2-9
  - for 16-bit or 12-bit operation 2-10
  - for calibration 2-10
  - SCAN-AD-HR boards 2-8
  - SCAN-BRD assemblies 2-10
  - the assembly address 2-12
  - the base I/O address 2-8
  - the channel inputs 2-13
  - the CJC input 2-15
- connecting
  - 7BP16 backplanes 3-28
  - an external clock/trigger/gate input 3-28
  - current signals 3-7
  - field wiring 3-3
  - isolated thermocouple signals 3-9
  - isolated voltage signals 3-6
  - multiple chassis 3-26
  - nonisolated thermocouple signals 3-8
  - nonisolated voltage signals 3-5
  - SCAN-AD-HR to the chassis 3-25
  - SCAN-CAB-64 cables to the SCAN-STPs 3-27
  - signal-conditioning backplanes 3-28
- connector frame 3-11
- control panel utility 1-6, 4-1
- conversion modes 7-13
- conversion rate 7-13
- counter/timer 7-14, 7-18
- creating a configuration file 2-16
- CTLSCAN.EXE utility 1-6, 4-1
- current measurements 3-7
  - connecting 3-7

## D

- DASSCAN.CFG utility 2-16
- data transfer 7-19
- default configuration 2-16
- differential inputs 3-5, 3-6

digital trigger 7-15, 7-16, 7-18  
DIN rail 1-2, 1-7, 3-2  
disabling CJC 2-15  
DMA 2-17, 7-17, 7-18, 7-19, 7-20  
DriverLINX NT software 1-6

## E

enabling CJC 2-15  
equipment, calibration 6-1  
external clock/trigger/gate input 2-9  
external digital trigger 7-15, 7-16, 7-18  
external pacer clock 7-14, 7-16

## F

features, system 1-2  
field wiring, connecting 3-3  
FIFO 7-19  
file, configuration 2-16  
filtering 7-7  
form, channel-mapping C-1  
frame, connector 3-11  
fuses 3-19

## G

gain 7-3, 7-7, 7-9  
gain control 7-11  
gate 7-18  
gate input 2-9  
    connecting 3-28  
GND A Return 7-7

## H

handling equipment 2-2  
hardware gate 7-18

## I

improving accuracy E-2  
input ranges 7-3, 7-11  
input-conditioning circuits 2-13, 7-6  
insertion block 1-7, 3-3  
inspecting equipment 2-2  
installation  
    ASO-SCAN software 2-4  
    chassis 3-10  
    SCAN-AD-HR board 3-25  
    SCAN-BRD assembly 3-22  
instrumentation amplifier 7-7, 7-9  
interface board 1-5, 2-8, 3-25, 7-9  
internal pacer clock 7-14, 7-16  
internal power, chassis 3-19  
internal trigger 7-15  
interrupt level 2-17, 7-19  
interrupt service routine 7-19  
IRQ level 2-17  
isolated thermocouple measurements 3-9  
isolated voltage measurements 3-6

## J

jumpers  
    12-bit or 16-bit operation 2-10  
    bank 2-14  
    base board 2-11  
    calibration 2-10  
    channel input 2-13  
    CJC enable/disable 2-15  
    external clock/trigger/gate 2-9  
    mezzanine board 2-11

## K

Keithley Memory Manager utility 1-6, 4-1,  
B-1  
KMM B-1  
KMMSETUP.EXE utility B-2

## L

labelling channel routes 3-1  
LEDs 4-3  
level, interrupt 2-17  
logical channels 2-16  
low-pass filter 7-7  
low-side bias return 7-7

## M

maximizing system performance E-1  
MB01 backplane 1-7  
connecting 3-28  
memory manager utility 4-1, B-1  
mode  
burst 7-13  
paced 7-13  
modifying a configuration file 2-16  
mounting a chassis 3-10  
mounting SCAN-STP panels 3-2  
multiple chassis 3-26  
multiplexer 7-7, 7-9

## N

noise, power-line E-4  
nonisolated thermocouple measurements 3-8  
nonisolated voltage measurements 3-5

## O

open thermocouple detection 2-15, 7-7  
options, bundles 2-3

## P

paced mode 7-13  
pacer clock 7-13, 7-14  
external 7-14, 7-16  
internal 7-14, 7-16  
performance, maximizing E-1  
polarity 7-14, 7-15, 7-18  
post-trigger acquisition 7-18  
potentiometers 6-1  
power cord 1-5, 3-19  
power supply 3-22  
power, chassis 3-19  
power-line noise reduction E-4  
power-up settings 2-16  
pre-trigger acquisition 7-17  
PWRCORD 1-5

## Q

QRAM circuit 7-3  
QRAM output lines 7-7, 7-9  
QRAM storage 7-11  
queue, channel-gain 7-11

## R

rack mounting 3-10  
ranges 7-3  
rate  
conversion 7-13  
pacer clock 7-13  
sample 7-13, 7-15

reducing power-line noise E-4  
returning equipment 5-10  
RMA number 5-10

## S

S-1802/M cable 1-5, 3-25, 3-26  
S-1802/MM cable 1-5, 3-26  
sample rate 7-13, 7-15  
scan 7-13  
SCAN-ADAPTER-HALF 1-7, 3-10  
SCAN-ADAPTER-MB adapter 1-7, 3-28  
SCAN-AD-HR board 1-5, 3-26, 7-2, 7-9  
    configuration 2-8  
    installing 3-25  
SCAN-BRD assembly 1-4, 2-10, 7-2  
    SCAN-BRD-TC 1-4, 7-4  
    SCAN-BRD-TC-ISO 1-4, 7-4  
    SCAN-BRD-V 1-4, 7-8  
    SCAN-BRD-V-ISO 1-4, 7-8  
SCAN-CAB-64 cable 1-4, 3-2  
    connecting to SCAN-STP panels 3-27  
SCAN-CH-FULL chassis 1-4  
SCAN-CH-FULL/NO PWR chassis 1-5  
SCAN-CH-HALF chassis 1-4  
SCAN-CH-HALF/NO PWR chassis 1-5  
SCAN-MOUNT-PAIR 1-7, 3-11  
scanning more than 256 channels E-1  
SCAN-SE-INSERT insertion block 1-7, 3-3  
SCAN-STP panel 1-4, 7-2, 7-3  
    connecting SCAN-CAB-64 cables 3-27  
    mounting 3-2  
    SCAN-STP-I 1-4, 7-3  
    SCAN-STP-TC 1-4, 7-4  
    SCAN-STP-V 1-4, 7-4  
screw terminal panels 1-4, 7-2, 7-3  
sequencing channels 7-11  
setting the base I/O address switch 2-8  
setting the channel input jumpers 2-13  
setting up chassis power 3-19

settling time 7-12  
signal conditioning 1-7, 3-28, 7-12  
signals, connecting 3-3  
single-ended inputs 3-5, 3-6  
software 1-5  
    ASO-SCAN 1-5  
    ASO-SCAN software 2-4  
    calibration utility 6-2  
    configuration utility 1-6, 2-16  
    control panel utility 1-6, 4-1  
    DriverLINX NT 1-6  
    Keithley Memory Manager utility 1-6  
    Testpoint 1-6  
    VTX 1-6  
software trigger 7-16  
specifications A-1  
start trigger 7-15, 7-17, 7-18  
surface mounting 3-10  
switch  
    base I/O address 2-8  
system features 1-2  
system throughput 7-12

## T

technical support 5-7  
test points 6-1  
testing chassis power 3-19  
Testpoint software 1-6  
thermocouple measurements  
    connecting isolated signals 3-9  
    connecting nonisolated signals 3-8  
throughput 7-12  
time base 7-14  
timing 7-13  
transferring data 7-19  
trigger 7-15

- trigger acquisition
  - about-trigger 7-18
  - post-trigger 7-18
  - pre-trigger 7-17
- trigger input 2-9
  - connecting 3-28
- troubleshooting 5-1

## U

- unipolar input range 7-11
  - configuring 2-18
- unpacking equipment 2-2
- utilities
  - calibration 6-2
  - configuration 1-6, 2-16
  - control panel 1-6, 4-1
  - Keithley Memory Manager 1-6

## V

- VDMAD.386 B-1
- VDMAD.VXD B-1
- virtual board 2-16
- voltage measurements
  - connecting isolated signals 3-6
  - connecting nonisolated signals 3-5
- VTX software 1-6

## W

- warranty repairs 5-11
- wiring signals 3-3

## Z

- zero drift compensation E-3