

**Tektronix BERTScope
Bit Error Rate Analyzers
BSA85C, BSA125C, BSA175C, BSA286CL
Quick Start User Manual**



071-2869-04

Tektronix

**Tektronix BERTScope
Bit Error Rate Analyzers
BSA85C, BSA125C, BSA175C, BSA286CL
Quick Start User Manual**

Revision A

www.tektronix.com

071-2869-04

Tektronix

Copyright © Tektronix. All rights reserved. Licensed software products are owned by Tektronix or its subsidiaries or suppliers, and are protected by national copyright laws and international treaty provisions.

Tektronix products are covered by U.S. and foreign patents, issued and pending. Information in this publication supersedes that in all previously published material. Specifications and price change privileges reserved.

TEKTRONIX and TEK are registered trademarks of Tektronix, Inc.

Contacting Tektronix

Tektronix, Inc.
14150 SW Karl Braun Drive
P.O. Box 500
Beaverton, OR 97077
USA

For product information, sales, service, and technical support:

- In North America, call 1-800-833-9200.
- Worldwide, visit www.tektronix.com to find contacts in your area.

Warranty

Tektronix warrants that this product will be free from defects in materials and workmanship for a period of one (1) year from the date of shipment. If any such product proves defective during this warranty period, Tektronix, at its option, either will repair the defective product without charge for parts and labor, or will provide a replacement in exchange for the defective product. Parts, modules and replacement products used by Tektronix for warranty work may be new or reconditioned to like new performance. All replaced parts, modules and products become the property of Tektronix.

In order to obtain service under this warranty, Customer must notify Tektronix of the defect before the expiration of the warranty period and make suitable arrangements for the performance of service. Customer shall be responsible for packaging and shipping the defective product to the service center designated by Tektronix, with shipping charges prepaid. Tektronix shall pay for the return of the product to Customer if the shipment is to a location within the country in which the Tektronix service center is located. Customer shall be responsible for paying all shipping charges, duties, taxes, and any other charges for products returned to any other locations.

This warranty shall not apply to any defect, failure or damage caused by improper use or improper or inadequate maintenance and care. Tektronix shall not be obligated to furnish service under this warranty a) to repair damage resulting from attempts by personnel other than Tektronix representatives to install, repair or service the product; b) to repair damage resulting from improper use or connection to incompatible equipment; c) to repair any damage or malfunction caused by the use of non-Tektronix supplies; or d) to service a product that has been modified or integrated with other products when the effect of such modification or integration increases the time or difficulty of servicing the product.

THIS WARRANTY IS GIVEN BY TEKTRONIX WITH RESPECT TO THE PRODUCT IN LIEU OF ANY OTHER WARRANTIES, EXPRESS OR IMPLIED. TEKTRONIX AND ITS VENDORS DISCLAIM ANY IMPLIED WARRANTIES OF MERCHANTABILITY OR FITNESS FOR A PARTICULAR PURPOSE. TEKTRONIX' RESPONSIBILITY TO REPAIR OR REPLACE DEFECTIVE PRODUCTS IS THE SOLE AND EXCLUSIVE REMEDY PROVIDED TO THE CUSTOMER FOR BREACH OF THIS WARRANTY. TEKTRONIX AND ITS VENDORS WILL NOT BE LIABLE FOR ANY INDIRECT, SPECIAL, INCIDENTAL, OR CONSEQUENTIAL DAMAGES IRRESPECTIVE OF WHETHER TEKTRONIX OR THE VENDOR HAS ADVANCE NOTICE OF THE POSSIBILITY OF SUCH DAMAGES.

[W2 – 15AUG04]

Table of Contents

| | |
|--|------|
| Important safety information | iii |
| General safety summary | iii |
| Service safety summary | v |
| Terms in this manual | vi |
| Symbols and terms on the product | vi |
| Compliance information | vii |
| EMC compliance | vii |
| Safety compliance | viii |
| Environmental considerations | x |
| Preface | xi |
| Features and benefits | xi |
| Documentation | xii |
| Conventions used in this manual | xii |
| Introduction | xiii |
| Product description | xiii |
| Key specifications | xiv |
| Options | xiv |
| Installation | 1 |
| Standard accessories | 1 |
| Optional accessories | 1 |
| Site considerations | 2 |
| Preventing ESD | 2 |
| Power on the instrument | 3 |
| Power off the instrument | 4 |
| Operation | 5 |
| Front panel controls and connectors | 5 |
| Rear panel connectors | 8 |
| Menu overview | 10 |
| Access system information | 12 |
| Applications | 13 |
| Example 1: Configure the Pattern Generator | 13 |
| Example 2: Set up the Error Detector | 16 |
| Identify Pattern Generator and Error Detector synchronization problems | 18 |
| Example 3: Reset the BER and Resyncs to zero | 19 |
| Reference | 20 |
| Operating system restore | 20 |
| User service | 21 |
| Service offerings | 21 |
| General care | 21 |
| Preventive maintenance | 21 |
| Connector replacement | 23 |
| Fuse replacement | 23 |

Table of Contents

| | |
|---|----|
| Instrument calibration | 23 |
| Repack the instrument for shipment..... | 23 |
| Specifications | 24 |
| Index | |

Important safety information

This manual contains information and warnings that must be followed by the user for safe operation and to keep the product in a safe condition.

To safely perform service on this product, additional information is provided at the end of this section. (See page v, *Service safety summary*.)

General safety summary

Use the product only as specified. Review the following safety precautions to avoid injury and prevent damage to this product or any products connected to it. Carefully read all instructions. Retain these instructions for future reference.

Comply with local and national safety codes.

For correct and safe operation of the product, it is essential that you follow generally accepted safety procedures in addition to the safety precautions specified in this manual.

The product is designed to be used by trained personnel only.

Only qualified personnel who are aware of the hazards involved should remove the cover for repair, maintenance, or adjustment.

Before use, always check the product with a known source to be sure it is operating correctly.

This product is not intended for detection of hazardous voltages.

Use personal protective equipment to prevent shock and arc blast injury where hazardous live conductors are exposed.

While using this product, you may need to access other parts of a larger system. Read the safety sections of the other component manuals for warnings and cautions related to operating the system.

When incorporating this equipment into a system, the safety of that system is the responsibility of the assembler of the system.

To avoid fire or personal injury

Use proper power cord. Use only the power cord specified for this product and certified for the country of use.

Do not use the provided power cord for other products.

Ground the product. This product is grounded through the grounding conductor of the power cord. To avoid electric shock, the grounding conductor must be connected to earth ground. Before making connections to the input or output terminals of the product, make sure that the product is properly grounded.

Do not disable the power cord grounding connection.

Power disconnect. The power cord disconnects the product from the power source. See instructions for the location. Do not position the equipment so that it is difficult to disconnect the power cord; it must remain accessible to the user at all times to allow for quick disconnection if needed.

Connect and disconnect properly. Do not connect or disconnect probes or test leads while they are connected to a voltage source.

Observe all terminal ratings. To avoid fire or shock hazard, observe all ratings and markings on the product. Consult the product manual for further ratings information before making connections to the product.

Do not apply a potential to any terminal, including the common terminal, that exceeds the maximum rating of that terminal.

The measuring terminals on this product are not rated for connection to mains or Category II, III, or IV circuits.

Do not operate without covers. Do not operate this product with covers or panels removed, or with the case open. Hazardous voltage exposure is possible.

Avoid exposed circuitry. Do not touch exposed connections and components when power is present.

Do not operate with suspected failures. If you suspect that there is damage to this product, have it inspected by qualified service personnel.

Disable the product if it is damaged. Do not use the product if it is damaged or operates incorrectly. If in doubt about safety of the product, turn it off and disconnect the power cord. Clearly mark the product to prevent its further operation.

Before use, inspect voltage probes, test leads, and accessories for mechanical damage and replace when damaged. Do not use probes or test leads if they are damaged, if there is exposed metal, or if a wear indicator shows.

Examine the exterior of the product before you use it. Look for cracks or missing pieces.

Use only specified replacement parts.

Use proper fuse. Use only the fuse type and rating specified for this product.

Wear eye protection. Wear eye protection if exposure to high-intensity rays or laser radiation exists.

Do not operate in wet/damp conditions. Be aware that condensation may occur if a unit is moved from a cold to a warm environment.

Do not operate in an explosive atmosphere.

Keep product surfaces clean and dry. Remove the input signals before you clean the product.

Provide proper ventilation. Refer to the installation instructions in the manual for details on installing the product so it has proper ventilation.

Slots and openings are provided for ventilation and should never be covered or otherwise obstructed. Do not push objects into any of the openings.

Provide a safe working environment. Always place the product in a location convenient for viewing the display and indicators.

Avoid improper or prolonged use of keyboards, pointers, and button pads. Improper or prolonged keyboard or pointer use may result in serious injury.

Be sure your work area meets applicable ergonomic standards. Consult with an ergonomics professional to avoid stress injuries.

Use care when lifting and carrying the product. This product is provided with handles for lifting and carrying.

Service safety summary

The *Service safety summary* section contains additional information required to safely perform service on the product. Only qualified personnel should perform service procedures. Read this *Service safety summary* and the *General safety summary* before performing any service procedures.

To avoid electric shock. Do not touch exposed connections.

Do not service alone. Do not perform internal service or adjustments of this product unless another person capable of rendering first aid and resuscitation is present.

Disconnect power. To avoid electric shock, switch off the product power and disconnect the power cord from the mains power before removing any covers or panels, or opening the case for servicing.

Use care when servicing with power on. Dangerous voltages or currents may exist in this product. Disconnect power, remove battery (if applicable), and disconnect test leads before removing protective panels, soldering, or replacing components.

Verify safety after repair. Always recheck ground continuity and mains dielectric strength after performing a repair.

Terms in this manual

These terms may appear in this manual:



WARNING. Warning statements identify conditions or practices that could result in injury or loss of life.



CAUTION. Caution statements identify conditions or practices that could result in damage to this product or other property.

Symbols and terms on the product

These terms may appear on the product:

- DANGER indicates an injury hazard immediately accessible as you read the marking.
- WARNING indicates an injury hazard not immediately accessible as you read the marking.
- CAUTION indicates a hazard to property including the product.



When this symbol is marked on the product, be sure to consult the manual to find out the nature of the potential hazards and any actions which have to be taken to avoid them. (This symbol may also be used to refer the user to ratings in the manual.)

The following symbol(s) may appear on the product:



CAUTION
Refer to Manual



Protective Ground
(Earth) Terminal



Earth Terminal



Chassis Ground



Mains Disconnected
OFF (Power)



Mains Connected
ON (Power)



Standby



WARNING
High Voltage

Compliance information

This section lists the EMC (electromagnetic compliance), safety, and environmental standards with which the instrument complies.

EMC compliance

EC Declaration of Conformity – EMC

Meets intent of Directive 2004/108/EC for Electromagnetic Compatibility. Compliance was demonstrated to the following specifications as listed in the Official Journal of the European Communities:

EN 61326-1 2006. EMC requirements for electrical equipment for measurement, control, and laboratory use. ^{1 2 3}

- CISPR 11:2003. Radiated and conducted emissions, Group 1, Class A
- IEC 61000-4-2:2001. Electrostatic discharge immunity
- IEC 61000-4-3:2002. RF electromagnetic field immunity
- IEC 61000-4-4:2004. Electrical fast transient / burst immunity
- IEC 61000-4-5:2001. Power line surge immunity
- IEC 61000-4-6:2003. Conducted RF immunity
- IEC 61000-4-11:2004. Voltage dips and interruptions immunity

EN 61000-3-2:2006. AC power line harmonic emissions

EN 61000-3-3:1995. Voltage changes, fluctuations, and flicker

European contact.

Tektronix UK, Ltd.
Western Peninsula
Western Road
Bracknell, RG12 1RF
United Kingdom

- ¹ This product is intended for use in nonresidential areas only. Use in residential areas may cause electromagnetic interference.
- ² Emissions which exceed the levels required by this standard may occur when this equipment is connected to a test object.
- ³ For compliance with the EMC standards listed here, high quality shielded interface cables should be used.

Australia / New Zealand Declaration of Conformity – EMC

Complies with the EMC provision of the Radiocommunications Act per the following standard, in accordance with ACMA:

- CISPR 11:2003. Radiated and Conducted Emissions, Group 1, Class A, in accordance with EN 61326-1:2006.

Australia / New Zealand contact.

Baker & McKenzie
Level 27, AMP Centre
50 Bridge Street
Sydney NSW 2000, Australia

Safety compliance

This section lists the safety standards with which the product complies and other safety compliance information.

EU declaration of conformity – low voltage

Compliance was demonstrated to the following specification as listed in the Official Journal of the European Union:

Low Voltage Directive 2006/95/EC.

- EN 61010-1. Safety Requirements for Electrical Equipment for Measurement, Control, and Laboratory Use – Part 1: General Requirements.

U.S. nationally recognized testing laboratory listing

- UL 61010-1. Safety Requirements for Electrical Equipment for Measurement, Control, and Laboratory Use – Part 1: General Requirements.

Canadian certification

- CAN/CSA-C22.2 No. 61010-1. Safety Requirements for Electrical Equipment for Measurement, Control, and Laboratory Use – Part 1: General Requirements.

Additional compliances

- IEC 61010-1. Safety Requirements for Electrical Equipment for Measurement, Control, and Laboratory Use – Part 1: General Requirements.

Equipment type

Test and measuring equipment.

Safety class

Class 1 – grounded product.

Pollution degree descriptions

A measure of the contaminants that could occur in the environment around and within a product. Typically the internal environment inside a product is considered to be the same as the external. Products should be used only in the environment for which they are rated.

- Pollution degree 1. No pollution or only dry, nonconductive pollution occurs. Products in this category are generally encapsulated, hermetically sealed, or located in clean rooms.
- Pollution degree 2. Normally only dry, nonconductive pollution occurs. Occasionally a temporary conductivity that is caused by condensation must be expected. This location is a typical office/home environment. Temporary condensation occurs only when the product is out of service.
- Pollution degree 3. Conductive pollution, or dry, nonconductive pollution that becomes conductive due to condensation. These are sheltered locations where neither temperature nor humidity is controlled. The area is protected from direct sunshine, rain, or direct wind.
- Pollution degree 4. Pollution that generates persistent conductivity through conductive dust, rain, or snow. Typical outdoor locations.

Pollution degree rating

Pollution degree 2 (as defined in IEC 61010-1). Rated for indoor, dry location use only.

Measurement and overvoltage category descriptions

Measurement terminals on this product may be rated for measuring mains voltages from one or more of the following categories (see specific ratings marked on the product and in the manual).

- Category II. Circuits directly connected to the building wiring at utilization points (socket outlets and similar points).
- Category III. In the building wiring and distribution system.
- Category IV. At the source of the electrical supply to the building.

NOTE. Only mains power supply circuits have an overvoltage category rating. Only measurement circuits have a measurement category rating. Other circuits within the product do not have either rating.

Mains overvoltage category rating

Overvoltage category II (as defined in IEC 61010-1).

Environmental considerations

This section provides information about the environmental impact of the product.

Product end-of-life handling

Observe the following guidelines when recycling an instrument or component:

Equipment recycling. Production of this equipment required the extraction and use of natural resources. The equipment may contain substances that could be harmful to the environment or human health if improperly handled at the product's end of life. To avoid release of such substances into the environment and to reduce the use of natural resources, we encourage you to recycle this product in an appropriate system that will ensure that most of the materials are reused or recycled appropriately.



This symbol indicates that this product complies with the applicable European Union requirements according to Directives 2002/96/EC and 2006/66/EC on waste electrical and electronic equipment (WEEE) and batteries. For information about recycling options, check the Support/Service section of the Tektronix Web site (www.tektronix.com).

Mercury notification. This product uses an LCD backlight lamp that contains mercury. Disposal may be regulated due to environmental considerations. Please contact your local authorities or, within the United States, refer to the E-cycling Central Web page (www.eiae.org) for disposal or recycling information.

Perchlorate materials. This product contains one or more type CR lithium batteries. According to the state of California, CR lithium batteries are classified as perchlorate materials and require special handling. See www.dtsc.ca.gov/hazardouswaste/perchlorate for additional information.

Restriction of hazardous substances

This product is classified as an industrial monitoring and control instrument, and is not required to comply with the substance restrictions of the recast RoHS Directive 2011/65/EU until July 22, 2017.

Preface

This document provides high-level information on the Tektronix BERTScope Bit Error Rate Analyzers. It helps you install and use the instruments.

Features and benefits

The BERTScope series of instruments provide the following features and benefits:

- Pattern Generation and Error Analysis, High-speed BER Measurements up to 28.6 Gb/s
- Integrated, Calibrated Stress Generation to Address the Stressed Receiver Sensitivity and Clock Recovery Jitter Tolerance Test Requirements for a Wide Range of Standards
- Electrical Stressed Eye Testing for the following:
 - PCI Express
 - 10/40/100 Gb Ethernet
 - SFP+/SFI
 - XFP/XFI
 - OIF/CEI
 - Fibre Channel (FC8, FC16, FC32)
 - SATA
 - USB 3.0
 - InfiniBand (SDR, QDR, FDR, EDR)
- Jitter Tolerance Compliance Template Testing with Margin Testing
- Fast Input Rise Time / High Input Bandwidth Error Detector for Accurate Signal Integrity Analysis
- Physical Layer Test Suite with Mask Testing, Jitter Peak, BER Contour, and Q-factor Analysis for Comprehensive Testing with Standard or User-defined Libraries of Jitter Tolerance Templates
- Integrated Eye Diagram Analysis with BER Correlation
- Optional Jitter Map Comprehensive Jitter Decomposition – with Long Pattern (PRBS-31) Jitter Triangulation to Extend BER-based Jitter Decomposition Beyond the Limitations of Dual Dirac TJ, DJ, and RJ for a Comprehensive Breakdown of Jitter Subcomponents
- Patented Error Location Analysis enables Rapid Understanding of your BER Performance Limitations and Assess Deterministic versus Random Errors, Perform Detailed Pattern-dependent Error Analysis, Perform Error Burst Analysis, or Error-free Interval Analysis

Documentation

In addition to Quick Start user manual, the following documentation is available on the instrument:

- Online help, including remote control commands
- Online remote control guide (PDF)

Online help is available for most controls and instrument features. Touch a control on the screen and the select the “Help on ...” listing for help on that control or feature.

Check the Tektronix Web Site for additional product documentation at www.Tektronix.com.

Conventions used in this manual

conventions

The following icons are used throughout this manual.

Sequence
Step



Front panel
power



Connect
power

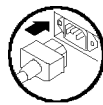

Network

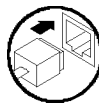

PS2

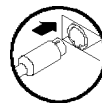

SVGA

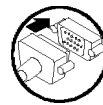

USB

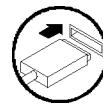

The terms “touch” and “click” are used interchangeably in this document. The instrument has a touchscreen interface to control the instrument by touching buttons or controls on the screen or by using a mouse.

The terms “view” and “menu” are used interchangeably in this document. A view is defined as the current on-screen menu.

NOTE. A notice statement identifies conditions under which may result in unintended operating modes, incorrect measurement results, or require resetting the instrument or personal computers operating software interacting with it.

Introduction

The Tektronix BERTScope BSA85C, BSA125C, BSA175C, BSA286CL Bit Error Rate Analyzers support serial data interfaces from 1 Gb Ethernet to future 16x Fibre Channel and 4x 25.78 Gb/s 100 Gb Ethernet. BERTScope Bit Error Rate Analyzers reduce your time to market by providing the most advanced and comprehensive combination of signal integrity analysis and test tools available in a single instrument.

The BERTScope analyzer has the comprehensive set of tools you need to perform receiver compliance testing, transmitter debug, and advanced analysis to 28.6 Gb/s. Featuring easy and flexible stress testing, physical layer analysis such as BER Contour and Jitter measurements, and a Compliance Contour view for Mask Test, it represents a breakthrough in insight and saved development time. Compliance Contour is a bridge between BER and mask testing, needed to meet the requirements of standards such as OIF CEI, 40/100G Ethernet XLAUI/CAUI, and XFP/XFI.

NOTE. *Optical transmitter compliance tests such as those required for optical 8x and 16x Fibre Channel, 10 GBASE-SR, LR, and 40 and 100 GBASE-SR-4, LR-4, SR-10, and ER-4 are best addressed by the Tektronix DSA8300 sampling oscilloscope with the appropriate reference receiver module.*

Use the BERTScope analyzer together with the Tektronix BERTScope Clock Recovery instruments and the Digital pre-emphasis processors to provide a complete testing solution.

Product description

This document supports the following Tektronix BERTScope Bit Error Rate Analyzers:

- BSA85C, Single Channel, BERTScope 8.5 Gb/s Bit Error Rate Analyzer
- BSA125C, BERTScope 12.5 Gb/s Bit Error Rate Analyzer
- BSA175C, BERTScope 17.5 Gb/s Bit Error Rate Analyzer
- BSA286CL, BERTScope 28.6 Gb/s Bit Error Rate Analyzer

The Tektronix BERTScope Bit Error Rate Analyzers provide methods of measuring the signal integrity of serial data systems. They provide quick, accurate, and thorough bit error ratio detection by bridging eye diagram analysis with BER pattern generation. These instruments help isolate problematic bit and pattern sequences and analyze seven types of advanced error analysis with statistical measurement depth.

The instruments have a software-based graphical user interface from a series of View menus. Detailed information on the operation of the control interface can be accessed at any time through the Help menus available in the separate View menus.

Key specifications

The following key specifications are common to all BSA instruments:

- Stressed Eye – SJ, RJ, BUJ, SI:
 - Option STR
- Output Rise Time & Jitter
 - 25 ps, 23 ps typical, rise time (10-90%)
 - <10 ps_{p-p} typical jitter (20-80%)
- Output Voltage Range
 - 250 mV to 2 V
- Input Sensitivity
 - 100 mV_{p-p} single ended (typical)
 - 50 mV_{p-p} differential (typical)

Options

The following table lists the options available for all BERTScope analyzers:

Table i: BERTScope analyzer options

| Item | Description |
|-------------------|--|
| ECC ¹ | Add Error Correction Coding Emulation Software |
| F2 | F/2 Jitter Generation at 8G/10.3125G (requires Option STR) |
| J-MAP | Add Jitter Decomposition Software |
| JTOL ¹ | Add Jitter Tolerance Templates Software |
| LDA | Add Live Data Analysis Software |
| MAP ¹ | Add Error Mapping Analysis Software |
| PCISTR | Add PCIe Extended Stress Generation |
| PL ¹ | Add Physical Layer Test Suite Software |
| PVU | Add PatternVu Equalization Processing Software |
| SF ¹ | Add Symbol Filtering option Software |
| SLD | Add Stressed Live Data option SW |
| STR | Stressed Signal Generation (Includes options ECC, MAP, PL, XSSC, JTOL, SF) |
| XSSC ¹ | Extended Spread Spectrum Clocking (SSC) |

¹ Included in Option STR

Installation

Standard accessories

- This Quick Start user manual
- USB keyboard
- USB mouse
- Power cord
- Short low-loss SMA cables

Optional accessories

Table 1: BERTScope analyzer accessories

| Accessory | Description |
|------------------|--|
| CR125ACBL | High performance Delay Matched Cable Set (required for BERTScope analyzer and Clock Recovery instrument in SSC applications) |
| 100PSRTFILTER | 100 ps rise time filter |
| BSA12500ISI | Differential ISI board |
| PMCABLE1M | Precision phase matched cable pair, 1 m |
| SMAPOWERDIV | SMA power dividers |
| BSARACK | BSA-rackmount kits |
| BSAUSB3 | USB3 Instrument Switch with cables and automation software |

Site considerations

Read this section before installing the instrument. This section describes environmental considerations, operating requirements, and power considerations.

Table 2: Environmental considerations

| Characteristic | Description |
|-----------------------|------------------------------------|
| Warm-up time | 20 minutes |
| Operating temperature | 10 °C to 35 °C (50 °F to 95 °F) |
| Operating Humidity | Noncondensing at 35 °C, 15% to 65% |

Place the instrument on a cart or bench. The instrument should rest on its bottom or rear feet. An optional rack mounting kit is available. Observe the following clearance requirements:

Table 3: Clearance requirements

| Feature | Description |
|----------------------|--|
| Top | 0 mm (0 in) |
| Left and right sides | 76 mm (3.0 in) |
| Bottom | 0 mm (0 in) standing on feet, flip stands down |
| Rear | 0 mm (0 in) on rear feet |

Table 4: Instrument power requirements

| Feature | Description |
|---------------------|---------------------------------------|
| Power | 460 W Maximum |
| Voltage & frequency | 100 to 240 V _{AC} , 50/60 Hz |
| Fuse | 5A, 250 V, 5 mm x 20 mm, fast blow |

Preventing ESD



CAUTION. A direct electrostatic discharge can damage the instrument input. To learn how to avoid this damage, read the following information.

Electrostatic discharge (ESD) is a concern when handling any electronic equipment. The instrument is designed with robust ESD protection; however it is still possible that large discharges of static electricity directly into the signal input may damage the instrument. To avoid damage to the instrument, use the following techniques to prevent electrostatic discharge to the instrument.

1. Discharge the static voltage from your body by wearing a grounded antistatic wrist strap while connecting and disconnecting cables and adapters. The instrument provides a front panel connection for this purpose.
2. A cable that is left unconnected on a bench can develop a large static charge. Discharge the static voltage from all cables before connecting them to the instrument or device under test by momentarily grounding the center conductor of the cable, or by connecting a 50 Ω termination to one end, before attaching the cable to the instrument.

Power on the instrument

The following sections assumes that you have properly connected the input and output cables to the instrument before you power on the instrument.

1. Connect the power cord to the rear of the instrument and to a properly grounded power source.

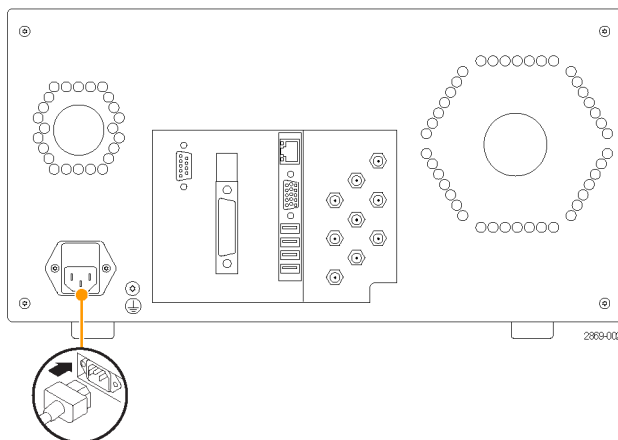

2. Push the front panel power button to turn the instrument on.

The green power indicator on the button will turn on and the instrument will begin the startup process.

The instrument performs a self-test at start-up. If any tests fail, the tests are listed in the Self Test dialog box. Contact Technical Support for information on any failed tests and for recommended action.

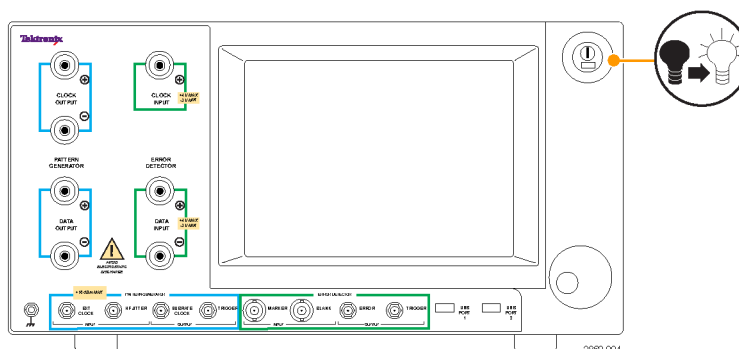

After the instrument completes the start-up sequence, the Home view displays.

From the Home view, access other menus of the instrument by touching the View button. The contents of the list under the View menu depend on the options and configuration of your instrument.

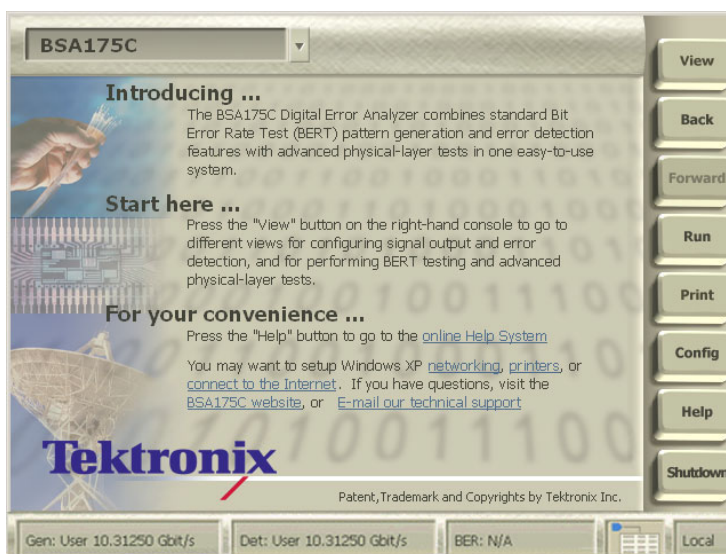

Power off the instrument

Use the Shutdown button to exit the BERTScope application before powering off the instrument. Do not turn the instrument off by holding down the front panel power button or by disconnecting the power cord.

1. Touch **Shutdown** on the lower-right side of the screen.
2. Do one of the following:
 - Select **Power down** to close the BERTScope application and power off the instrument.
 - Select **Exit Application** to close the BERTScope application and access the computer desktop.

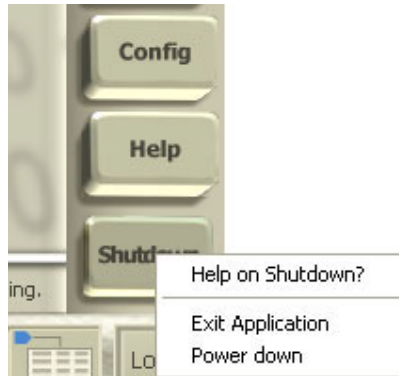

3. To power off the instrument from the computer desktop, close any active applications and then push the front panel power button. The green power indicator on the button will turn off and the instrument will begin the shut down process.

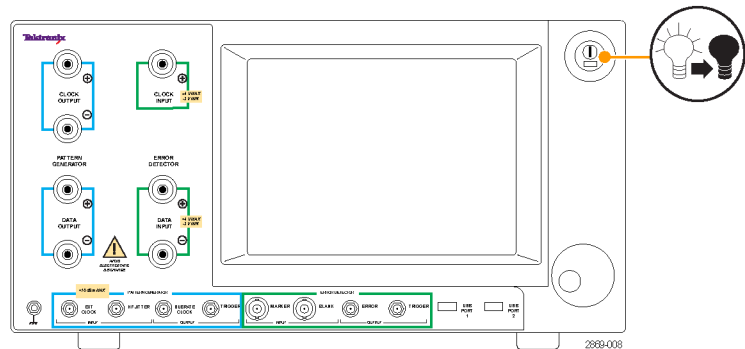

4. Disconnect the power cord from the rear of the instrument to completely remove power from the instrument after it shuts down.

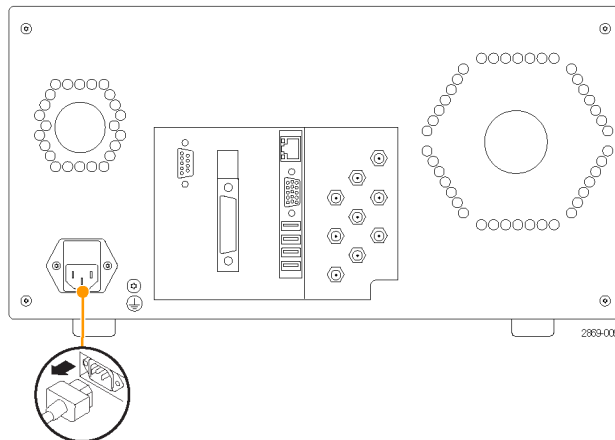

Operation

Front panel controls and connectors

The following figure and table describe common front panel controls and connectors.

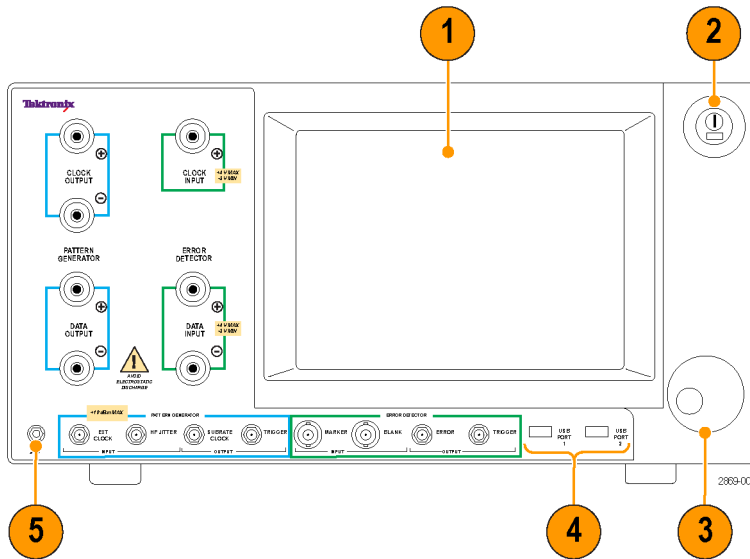

Figure 1: BSA front panel

Table 5: Common front panel controls and connectors

| Connector | Description |
|-----------|---|
| 1 | Display TFT touchscreen display to set up, control, and view information in the menus. |
| 2 | Power switch Activates the power supply to provide power to the primary circuits in the instrument. The switch has a green light when power is turned on. The primary power control circuitry is always live whenever the power cord is connected to the instrument. To completely disconnect power from the instrument, disconnect the power cord at the rear of the instrument. |
| 3 | Control knob Use the multifunction knob to control items in the display such as moving the cursor, scaling inputs, and zooming data. |
| 4 | USB Use the USB connectors for connecting USB devices such as a mouse, keyboard, or USB flash drive. Four additional USB connectors are located on the back of the instrument. |
| 5 | Ground connector Use this connector to connect a common ground to other instruments. |

The following figure and table describe the Pattern Generator front panel connectors (outlined in blue).

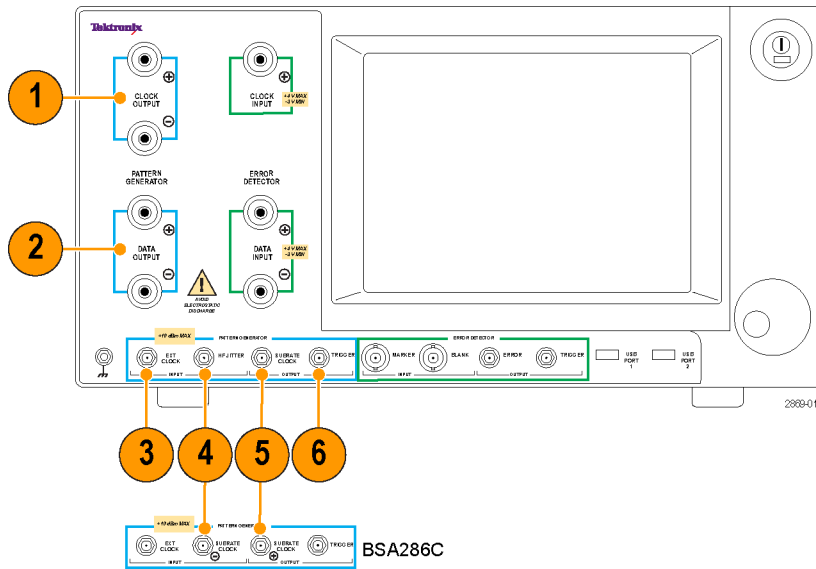

Figure 2: Pattern Generator front panel connectors

Table 6: Pattern Generator front panel connectors

| Connector | Description |
|-----------|--|
| 1 | CLOCK OUTPUT Clock Output connectors. Use the differential connectors to output a clock signal from the Pattern Generator. (Amplitude range: 250 mV to 2 V _{p-p}). |
| 2 | DATA OUTPUT Data Output connectors. Use the differential connectors to output data from the Pattern Generator. (Amplitude range: 250 mV to 2 V _{p-p}). |
| 3 | EXT CLOCK External clock input connector. Use this input to connect an external clock source to the BERTScope analyzer; (maximum input amplitude of +10 dBm or 2 V _{p-p}). |
| 4 | HF JITTER High-frequency jitter insertion input connector. Use this connector to add external high-frequency jitter (DC to 1 GHz) to the instrument with up to 0.5% UI. Apply signals up to 16 dBm (4 V _{p-p}) if needed. This connector is available on the rear panel of BSA286CL instruments. |
| | SUBRATE CLOCK- BSA286CL only, Pattern Generator Subrate clock-. Use this connector to provide the - side of a differential clock. The signal available at this output connector depend on the settings in the Generator view. Select SUBRATE to produce a Pattern Generator clock or a submultiple of the clock without any added jitter (useful for measuring any jitter that was added to the Pattern Generator output). Select STRESS to produce a version of the Pattern Generator clock including any added jitter. |
| 5 | SUBRATE CLOCK Pattern Generator Subrate clock output connector. (See the description above.) For the BSA286CL instruments, this is the + output of the differential signal. For other BSA versions, this is a single-ended output. |
| 6 | TRIGGER Pattern Generator trigger output connector. Use this connector to synchronize external equipment, such as an oscilloscope to the BERTScope analyzer. |

The following figure and table describe the Error Detector front panel connectors (outlined in green).

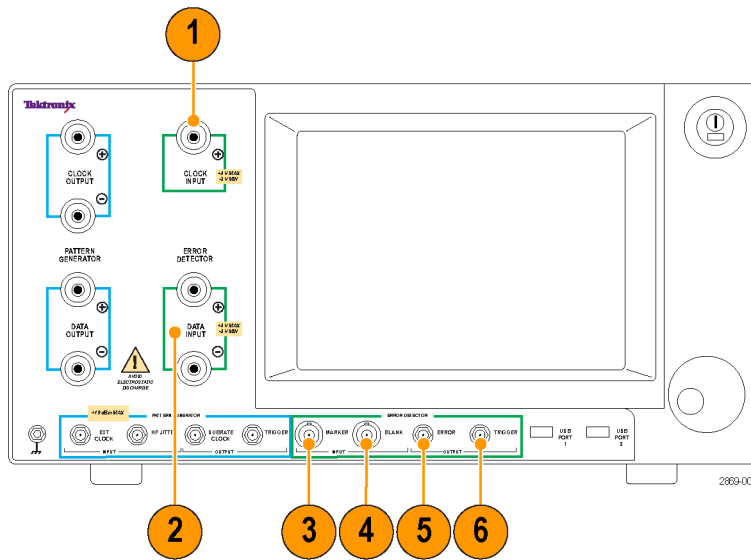

Figure 3: Error Detector front panel connectors

Table 7: Error Detector front panel connectors

| Connector | Description |
|------------------|--|
| 1 CLOCK INPUT | Error Detector clock input connector. Use this connector to provide a single-ended clock input to the Error Detector. The input frequency range depends on the instrument model. (Amplitude range: -2 V to $+3\text{ V}$, $50\ \Omega$, AC-coupled) |
| 2 DATA INPUT | Error Detector data input connectors. Use the Data+ and Data- connectors to input differential data signals to the Error Detector. (Amplitude range: -2 V to $+3\text{ V}$, $50\ \Omega$, AC-coupled) |
| 3 MARKER | Detector Marker input connector. Use this connector to accept a TTL-level Marker signal. The signal can be used to synchronize error analysis with low-speed reference signals, such as mechanical frequencies, packet boundaries, or loop markers. The minimum pulse width is 128 clock periods with a maximum repetition rate of 512 serial clock periods. |
| 4 BLANK | Error Blank input connector. Use this connector to accept a TTL-level signal to cause the Error Detector to ignore errors. The Error Detector will ignore errors while this signal is active. |
| 5 ERROR | Error output connector. Use this connector to provide a 1000 mV pulse when an error is detected. The minimum pulse width is 128 serial clock periods. |
| 6 TRIGGER | Trigger output connector. Use this connector to synchronize external equipment, such as an oscilloscope to the BERTScope analyzer. |

Rear panel connectors

The following figure and table describe the rear panel power and communication connectors. The location and type of connectors may vary depending on the instrument model.

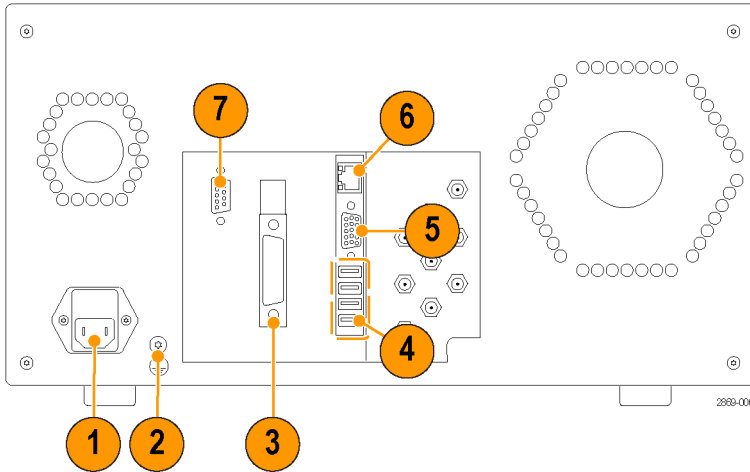

Figure 4: Rear panel connectors

Table 8: Rear panel power and communications connectors

| Connector | Description |
|-----------|---|
| 1 | AC power Connect a suitable power cord to match the local power outlet type. |
| 2 | Chassis ground screw Connect a common ground to other instruments. |
| 3 | IEEE4888 GPIB connector. |
| 4 | USB Four USB connectors (two additional connectors are located on the front of the instrument). Connect USB devices such as keyboard, mouse, or USB flash drive. |
| 5 | VIDEO Monitor/display connector. Connect an external VGA display device. |
| 6 | LAN Connect the instrument to a network for remote control operation, file sharing, and other network operations. |
| 7 | DPP SI LINK Miniature type D connector for standard RS232 communication. |

The following figure and table describe the rear panel BNC connectors. Pattern Generator connectors are on a blue background; Error Detector connectors are on a green background.

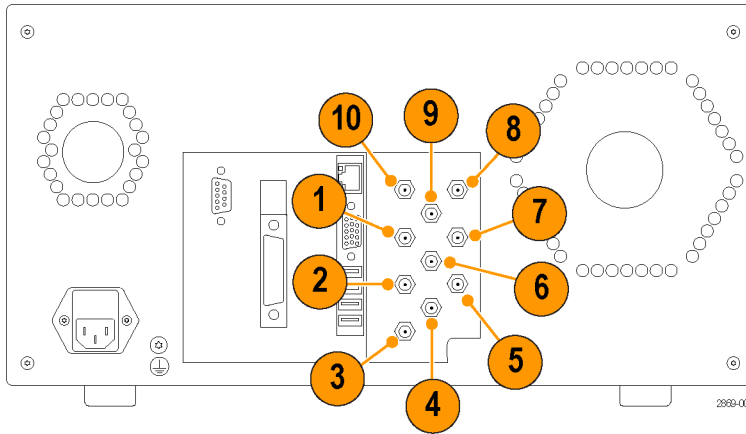

Figure 5: Rear panel BNC connectors

Table 9: Rear panel BNC connectors

| Connector | Description |
|--------------|---|
| 1 PAT START | Pattern Start input. Use this input connector to simultaneously synchronize the patterns of multiple data streams from multiple instruments. |
| 2 PAGE SEL | Page Select. If a User Pattern file with two pages is loaded into the Generator, this signal selects which page is being transmitted, based on the TTL level of the input signal. A logic 0 (low) selects Page A; a logic 1 (high) selects Page B. |
| 3 DET START | Detector Start Input. Use this input to synchronize the Error Detector with external equipment. (LVTTTL logic level, >1 kΩ into 0 V) |
| 4 SI OUT | Sine Interference Out. Use this connector to output a voltage waveform when the Sine Interference mode is set to External. The voltage range is from 0 mv to 3.0 V. For example, use this signal with external equipment to apply sinusoidal interference to an optical signal. |
| 5 REF- OUT | Reference Output (-). Use this connector with the (+) connector to provide a differential reference frequency for other instruments (typically 100 MHz). For single-ended applications, use the (+) connector. |
| 6 LF SIN-OUT | Low-Frequency Sine Jitter Out. Use this connector to track the internal sine jitter modulation frequency. It can be used to ensure that two BERTScope analyzers are both in-phase or out-of-phase. |
| 7 REF+ OUT | Reference Output (+). Use this connector with the (-) connector to provide a differential reference frequency for other instruments (typically 100 MHz). |
| 8 REF IN | Reference Input. Use this connector to provide an input reference signal (amplitude: -6 dBm to +6 dBm; frequencies: 10, 100, 106.25, 133.33, 165.25, 166.67, and 200 MHz). |
| 9 LF JIT-IN | Low Frequency Jitter In. Use this connector to add external low frequency jitter (DC to 80 MHz) to the instrument. The maximum signal level for this connector for normal operation is +10 dBm (2 V _{p-p}). |
| 10 HF JIT-IN | BSA286CL only. High-frequency jitter insertion input connector. Use this connector to add external high-frequency jitter (DC to 1 GHz) to the instrument with up to 0.5% UI. Apply signals up to 16 dBm (4 V _{p-p}) if needed. |

Menu overview

The BERTScope analyzer is controlled by a graphical user interface and on-screen controls. The on-screen controls can be accessed with the touch screen or with a mouse and keyboard.

The Home view displays when you first turn on the instrument. The Home view introduces the instrument and provides high-level on-screen information to help you get started using the instrument. It also provides useful links to help you set up the instrument, such as connecting to the Internet, connecting to a printer, or accessing the Tektronix BERTScope Web site.

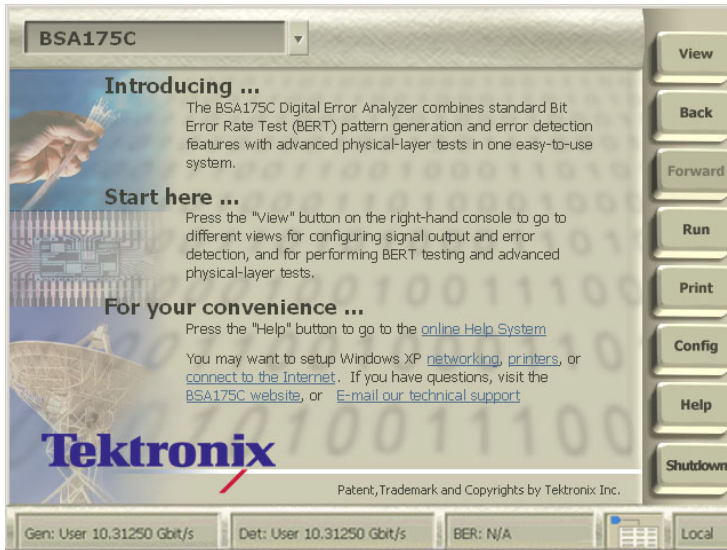

Figure 6: Home view

The Control console is common to all views. It consists of three major areas to help you control and navigate the different views:

- Title bar. The Title bar contains the name of your instrument and a history of recent views or views within a group. Touch any of the listed views to quickly return to that view.
- Control buttons. Use the buttons on the right side of the display to control the overall instrument operation. The following table provides a high-level overview of each button.

Table 10: Control console button overview





| Item | Description |
|---|--|
|  | Touch View to access a variety of views available on the BERTScope analyzer. The contents of the pop-up list depend on the features and options available with your instrument. |
|  | Touch Back or Forward to quickly scroll through the history of displayed views. The buttons become active after selecting different views. |
|  | Touch Run to start the Pattern Generator, Error Detector, or other data analysis application in the current view. The button lights up while the applications are running. Touch the button a second time to stop the applications. |

Table 10: Control console button overview (cont.)

| Item | Description |
|---|---|
|  | Touch the Print button to print the current view to a designated printer or to a file. Printer settings are made in the System view, on the Tools tab, under the Setup column. (Touch View and select System to access the System view). |
|  | Touch the Config button to access configuration files, which store the setups of your instrument. |
|  | Touch the Help button for easy access to the online help on the current view. |
|  | Touch the Shutdown button to quit the BERTScope application or to turn off the instrument. |

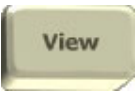
- Status bar. The Status bar provides information about the current operating status. It is made up of the following different areas:
 - Pattern Generator (Gen) and Error Detector (Det). These areas display the data pattern, measured clock frequency, and synchronization status. The areas will be yellow and display error messages if the system is not in sync.
 - Measured BER, Error Count, Bit Count. Touch this area to display the measured BER, error count, or bit count. The small image to the right animates when an analysis is running.
 - Local/remote control. This area indicates how the instrument is being controlled, locally or by remote control.

NOTE. The Gen or Det areas are shortcuts; touch one of these areas to take you directly to that view.

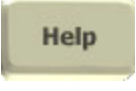
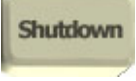
Access system information

The System view includes access to setup, test, and registry settings and information. You might need access to this information when you first set up your instrument.

Touch **View** and then select **System**.

The System view opens showing separate tabbed pages to access system information.

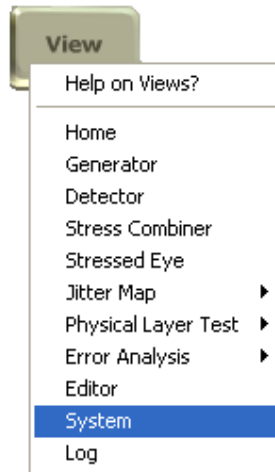

Under the Tools tab, touch any of the buttons to access setup information, view the desktop, use the Microsoft tools, or access the Internet.

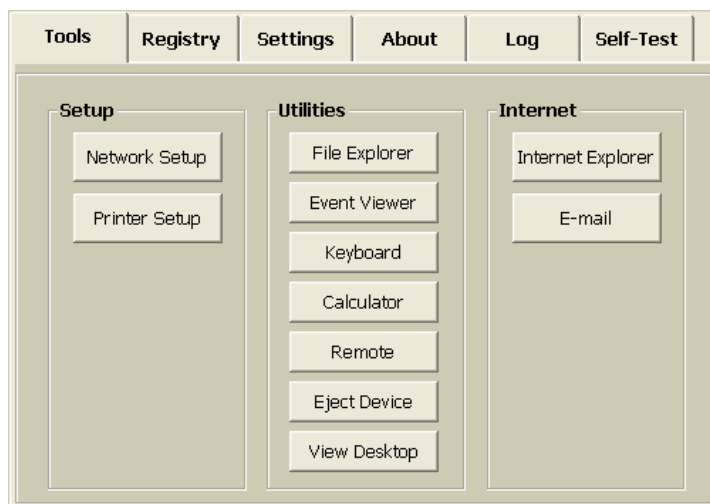

Touch other tabs in the System view for additional information:

- The Registry tab displays the current paths in the Windows file system for assets, such as user patterns or configurations.
- The Settings tab displays a list of user-definable settings. It also allows you to set preferences, such as whether dialog boxes appear to recommend calibration as appropriate. It also display product options installed in the instrument.
- The About tab provides information about your instrument, such as product name, serial number, and software versions.
- The Log tab allows you to view or clear the Error Log file. It also displays the path to the log file on your instrument.
- The Self-Test tab allows you to run the self test routine. The results of the self test are displayed on the screen and saved to the Error Log file.

Applications

The following examples provide simple exercises to help you get familiar with the BERTScope analyzer and to navigate the instrument views.

Example 1: Configure the Pattern Generator

This example provides examples of how to set up the Pattern Generator to output PRBS-7 data at a specified data rate using differential CMI voltage levels.

Connect the front panel cables

When connecting cables to the front panel use high quality coaxial cables with APC3.5 or SMA connectors.

Connect three SMA cables on the front panel as described below:

1. Connect an SMA cable from the Pattern Generator + Clock Output connector to the Error Detector Clock Input connector.
Terminate the Pattern Generator – Clock Output with a 50 Ω terminator.
2. Connect two SMA cables from the Pattern Generator +/- Data Output connectors to the Error Detector +/- Data Input connectors.
3. Power on the instrument.

Set up the Pattern Generator

Complete the following steps to configure the Pattern Generator.

1. Touch **View** on the control console and then select **Generator** to display the Generator view.

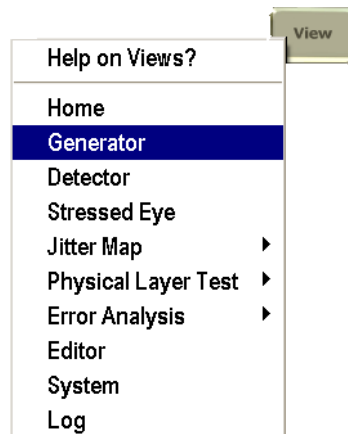

Example 1: Configure the Pattern Generator

2. Touch the SYNTHESIZER input icon on the Generator view to open the Internal Clock Input settings box and then select **Use Keypad**.

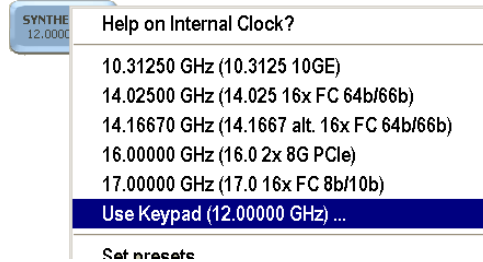

3. Enter 1.0 GHz and then touch **OK**.
The dialog box closes and the SYNTHESIZER input icon displays the new clock frequency.

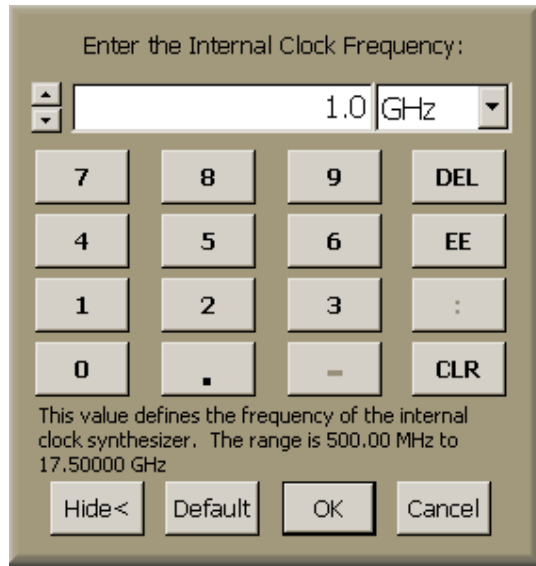

4. Touch the GENERATOR icon button in the center of the Generator view to open the Generator settings box.
5. Select Pattern from the first level list and then select PRBS-7 from the list.

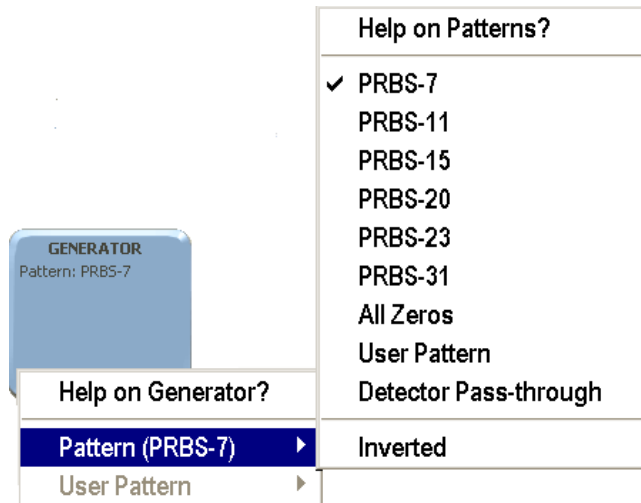

6. Touch the **CLOCK +** icon button and verify that **Link Clock +/- Signals** is selected.
This setting links the Clock + and Clock – outputs together.

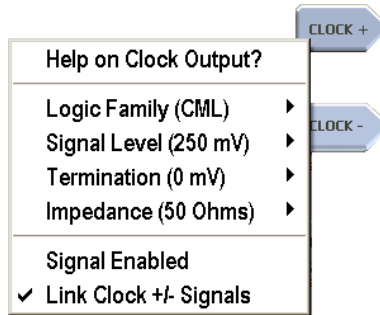

7. Select **Logic Family** in the list and then select **CML** from the pop-up list.
8. Repeat the previous two steps to set the outputs for the Data + output icons.

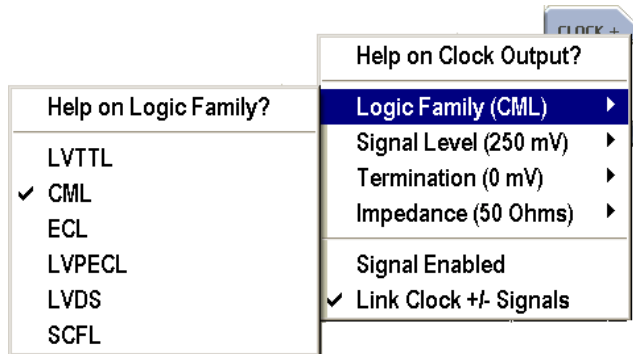

9. Touch the **Outputs On/Off** button at the top of the Generator view to enable the Clock and Data outputs.
When the Generator outputs are turned on, the clock and data information displays under the Clock and Data buttons.

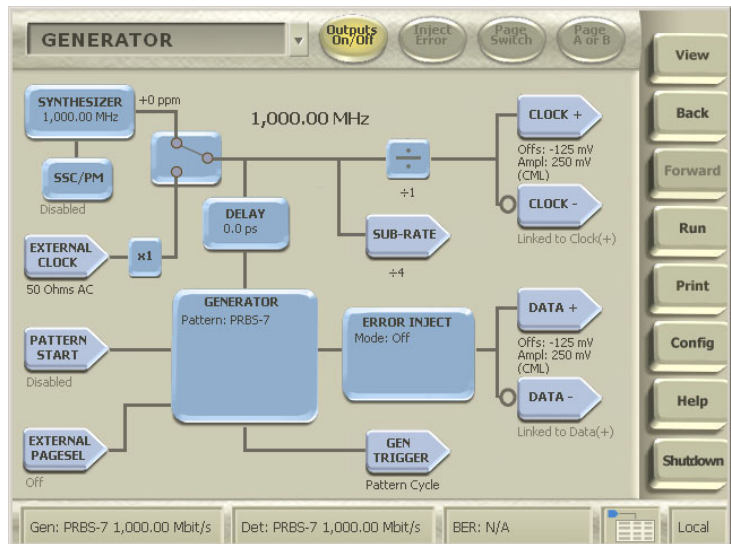

The Pattern Generator is now transmitting PRBS-7 data at 1 Gb/s on the clock and differential Data outputs set to the industry standard CML levels.

Example 2: Set up the Error Detector

This example uses the same setups as Example 1. It provides information on how to set up the Error Detector to accept differential CML signals and to make a bit error rate measurement.

NOTE. Before continuing, make sure that you have the high-quality coaxial cables as describe in Example 1. (See page 13, Connect the front panel cables.)

1. Touch **View** on the control console and then select **Detector** to display the Detector view.

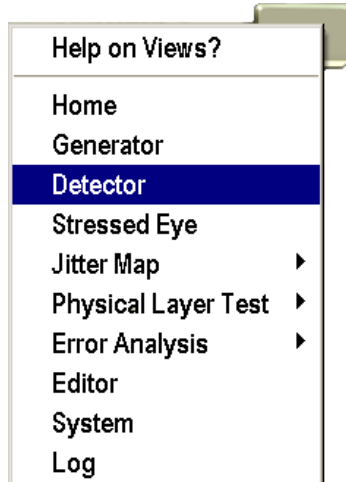

2. Touch the **Data** button, select **Interface Mode**, and then select **Differential**.
3. Touch the **Data** button again, select **Logic Family**, and then select **DIFF-CML/SCFL**.

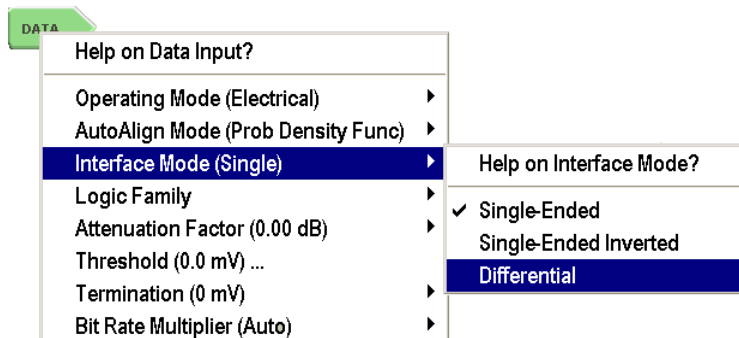

4. Touch the **Error Detector** icon and select **Auto Pattern** from the list.

This enables the Error Detector to compare all known PRBS data patterns when acquiring synchronization.

5. Clear the **Auto Resync** selection if it is selected.

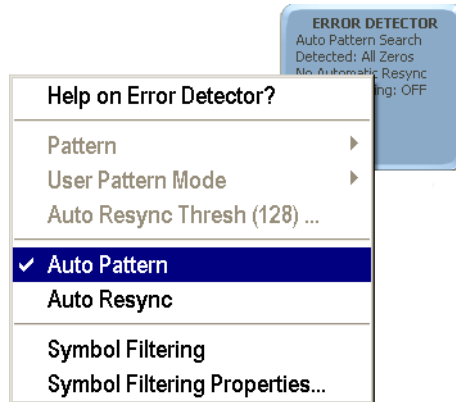

6. Touch the **Auto Align** button at the top of the Detector view.

The Auto Align optimizes the data measurement point with the incoming data signal. This moves the delay timing and voltage threshold to find the best sampling point in the received eye for making BER measurements.



The Auto Align Results dialog box displays if the Auto Align process is successful and synchronization is achieved.

NOTE. You might be asked to recalibrate the delay element when you touch the Auto Align button. The instrument monitors changes in data frequency and temperature; it can automatically recalibrate the built-in variable delay element within a few seconds.

7. Click **Ok** to close the dialog box.

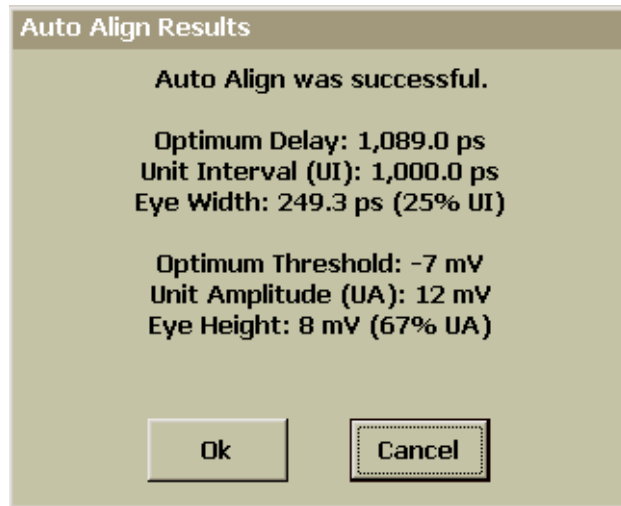

8. Verify that the data pattern type and the data rate are the same for the Pattern Generator and Error Detector (as displayed on the Status Bar at the bottom of the screen).



NOTE. In addition to using the View menus to navigate between the Generator and Detector views, you can easily navigate between the views by touching or clicking the Pattern Generator or Error Detector areas of the Status Bar at the bottom of the screen.

Identify Pattern Generator and Error Detector synchronization problems.

If the Pattern Generator and the Error Detector are not synchronized, you must address the problem before continuing. Use the following steps to help identify the source of the synchronization problems:

1. Verify that you are using the correct, high-quality coaxial cables with APC3.5 or SMA connectors.
2. Carefully check the cable connections to the instrument and the polarity of the connections; make any corrections as needed.
3. Check that the Pattern Generator has its clock outputs switched on (touch **Outputs On/Off**).
4. If the status information on the bottom of the Error Detector says **Unstable Clock**, check for the following:
 - Check that the Pattern Generator clock has the internal clock source selected, rather than external.
 - Check that the Clock Input termination is set to the same termination as the Generator clock output.
5. Verify that the Status Bar at the bottom of the Generator and Detector views show the same data type and data rate.

If synchronization is not achieved, the Status Bar will be a bright yellow color and displays **No Sync**. If this happens, check for the following:

- Check that the Error Detector Data Input termination is set to the same termination as the Generator output setting.
 - Check that the Error Detector Data Input is set to Differential input.
6. Verify that the data type is PRBS-7. If not, check for the following:
 - Check that the Data Type setting on the Generator view is set to PRBS-7. If necessary reset it to PRBS-7.
 - Check that the Data Type setting on the Detector view is set to PRBS-7. If necessary reset it to PRBS-7.
 7. Verify that the X1/X2 settings in the Detector view are correct for your application.
 8. Verify that the Generator Clock rate is set to 1 GHz. If necessary, reset it to 1.0 GHz.
 9. Verify that the Error Detector settings are the same as the Generator Clock and Data settings. This includes the Interface Mode and Logic Family settings. Change them as necessary.
 10. Try to resynchronize again by touching the **Auto Align** button.

Example 3: Reset the BER and Resyncs to zero

This example assumes that you have completed steps in this Examples 1 and 2 and that the instrument has achieved synchronization.

1. Touch the **Run** on the Control console two times to start and stop the detector.



The button changes color when the instrument is running.

2. Touch the **Reset Results** button at the top of the screen to reset the measurement results.



3. Check the Detector view for the following:

- The clock rate (**1,000.00 Mbit/s**) matches the 1 GHz rate being transmitted by the Generator.
- The data type is set to **PBRS-7**.
- The Detector Results box indicates zero BER and zero resyncs.

The screenshot shows the 'DETECTOR' view of the instrument. At the top, there are buttons for 'Inject Error', 'Auto Align', 'Manual Resync', and 'Reset Results'. The signal flow diagram shows a 'CLOCK' input (50 Ohms AC) passing through a 'x1' multiplier and a 'DELAY' block (1,785.0 ps) to a 'DET TRIGGER' (Pattern Cycle) at a rate of 1,000.00 Mbit/s. A 'DATA' input (Atten: 0.0 dB, Thrsh: -138.0 mV, 50 Ohms to 0 mV) is connected to an 'ERROR DETECTOR' block. The 'ERROR DETECTOR' block shows 'Auto Pattern Search Detected: PBRS-7', 'No Automatic Resync', and 'Symbol Filtering: OFF'. Below this is a 'DETECTOR RESULTS' table:

| DETECTOR RESULTS | |
|------------------|--------------------|
| Bits | 4,499,959,936 |
| Errors | 0 |
| BER | 0.00E+00 |
| Resyncs | 0 |
| Elapsed Time | 00:00:05 |
| Error Free | 4.50E+09, 00:00:05 |

At the bottom of the screen, there are status indicators: 'Gen: PBRS-7 1,000.00 Mbit/s', 'Det: PBRS-7 1,000.00 Mbit/s', and 'BER: 0.00E+00'. A control console on the right side contains buttons for 'View', 'Back', 'Forward', 'Run', 'Print', 'Config', 'Help', and 'Shutdown'.

Reference

Operating system restore

The BERTScope analyzer contains an operating system restore file in a separate partition of the hard drive. Use this file to restore the instrument operating system.



CAUTION. *Using the restore process reformats the hard drive and reinstalls the operating system. All saved data is lost. If possible, save important files to external media before performing a system restore.*

1. Restart the instrument. During the boot-up process you will see the following message at the top of the screen:

Acronis Loader

Press F5 to start the Acronis Startup Recovery Manager.
2. Repeatedly press the **F5** key until the Acronis True Image Tool opens. There is a 15-second delay after the message appears until the instrument proceeds with normal instrument startup. If the instrument does not open the Acronis application, power off the instrument, then power on the instrument and try again.
3. Touch **Restore**.
4. In the Confirmation dialog box, touch **Yes** to restore the instrument operating system, or **No** to exit the restore process. The restore process takes approximately 30 minutes; the actual time depends on the instrument configuration.
5. If you have not already done so, go to the Tektronix Web site to download the application software (www.tektronix.com/software) and follow the instructions to install the software for your instrument.

User service

This section describes high-level service information and procedures for your instrument.

Service offerings

Tektronix provides service to cover repair under warranty and other services that are designed to meet your specific service needs.

Whether providing warranty repair service or any of the other services listed below, Tektronix service technicians are well equipped to service the logic analyzers. Services are provided at Tektronix Service Centers and on-site at your facility, depending on your location.

Warranty repair service

Tektronix warrants this product as described in the warranty statements at the front of this manual. Tektronix technicians provide warranty service at most Tektronix service locations worldwide. The Tektronix product catalog lists all service locations worldwide.

Calibration and repair service

In addition to warranty repair, Tektronix Service offers calibration and other services that provide cost-effective solutions to your service needs and quality standards compliance requirements. Tektronix instruments are supported worldwide by the leading-edge design, manufacturing, and service resources of Tektronix to provide the best possible service.

General care

Protect the instrument from adverse weather conditions. The instrument is not waterproof. Do not store or leave the instrument where the display will be exposed to direct sunlight for long periods of time.



CAUTION. To avoid damage to the instrument, do not expose it to sprays, liquids, or solvents.

Preventive maintenance

Preventive maintenance mainly consists of periodic cleaning. Periodic cleaning reduces instrument breakdown and increases reliability. Clean the instrument as needed, based on the operating environment. Dirty conditions may require more frequent cleaning than computer room conditions.

Clean the flat panel display

The flat panel display is a soft plastic display and must be treated with care during cleaning.



CAUTION. Improper cleaning agents or methods can damage the flat panel display.

- Do not use abrasive cleaners or commercial glass cleaners to clean the display surface.
- Do not spray liquids directly on the display surface.
- Do not scrub the display with excessive force.
- Avoid getting moisture inside the instrument while cleaning the display; use only enough solution to dampen the wipe.
- Clean the flat panel display surface by gently rubbing the display with a cleanroom wipe (such as Wypall Medium Duty Wipes, #05701, available from Kimberly-Clark Corporation).
- If the display is very dirty, moisten the wipe with distilled water or a 75% isopropyl alcohol solution and gently rub the display surface. Avoid using excess force or you may damage the plastic display surface.

Clean the exterior surfaces

Clean the exterior surfaces with a dry, lint-free cloth or a soft-bristle brush. If dirt remains, use a cloth or swab dampened with a 75% isopropyl alcohol solution. A swab is useful for cleaning in narrow spaces around the controls and connectors. Do not use abrasive compounds on any part of the instrument.

To avoid damaging the instrument follow these precautions:

- Avoid getting moisture inside the instrument during external cleaning and use only enough solution to dampen the cloth or swab.
- Do not wash the front-panel power switch. Cover the switch while washing the instrument.
- Use only deionized water when cleaning. Use a 75% isopropyl alcohol solution as a cleanser and rinse with deionized water.
- Do not use chemical cleaning agents; they may damage the instrument. Avoid chemicals that contain benzene, toluene, xylene, acetone, or similar solvents.

Battery information

The coin cell battery on the instrument computer motherboard is not a user replaceable part. The coin cell battery is not rechargeable. Under no circumstances attempt to recharge the battery.

Connector replacement

The Pattern Generator CLOCK OUTPUT and CLOCK INPUT connectors and the Error Detector DATA OUTPUT and DATA INPUT connectors use 3.5 mm to PAC Planar Crown® adapters. These facilitate user replacement of the adapter, should it become damaged. Replacement adapters can be ordered from Tektronix.

Replace the front panel connectors

1. Remove a damaged connector by grasping the knurled outer part of the ring with your fingers and turning counterclockwise.

Do not allow foreign material to enter the connector body when replacing the adapter.

2. Position the two locating tabs in the corresponding slots of the instrument-mounted part of the connector and seat the replacement adapter.
3. Align the retaining ring and tighten by rotating clockwise

Tightened the connector finger-tight. To avoid over-tightening and possibly damaging the connector, do not use a tool to tighten it.

Fuse replacement

The instrument is protected by a fuse placed in series with the power line input. The fuse is conservatively rated and should never open through the life of the instrument. A blown fuse would generally indicate a problem with the instrument which requires factory service. It is recommended that you arrange to have the instrument serviced if you experience a blown fuse.

Instrument calibration

The instrument uses digital calibration of the output buffers. To maintain the accuracy of the output amplitude and offset, annual calibration is recommended. Contact Tektronix to schedule instrument calibration.

Repack the instrument for shipment

If the instrument is to be shipped to a Tektronix service center for repair, attach a tag showing the following information:

- Name of the product owner
- Address of the owner
- Instrument serial number
- A description of the problems encountered and/or service required

When packing an instrument for shipment, use the original packaging. If it is unavailable or not fit for use, contact your Tektronix representative to obtain new packaging.

Specifications

Table 11: PC-related specifications

| Characteristic | Description |
|----------------------|--|
| Display | TFT Touch screen, 640 x 480 VGA |
| Touch sensor | Analog resistive |
| Processor | Pentium® P4; 1.5 GHz or greater |
| Hard disk drive | 160 GB or greater |
| DRAM | 2 GB |
| Operating system | Microsoft Windows 7 Professional |
| Remote control | IEEE-488 (GPIB) or TCP/IP |
| Network connection | 100 base T Ethernet LAN |
| Supported interfaces | USB 2.0 (6 total, 2 front, 4 rear) VGA external display |

Table 12: Physical specifications

| Characteristic | Description |
|----------------|---|
| Weight | 25 kg (55 lbs), instrument only 34.5 kg (76 lbs), shipping |
| Dimensions | |
| Height | 22 cm (8.75 in) |
| Width | 39.4 cm (15.5 in) |
| Depth | 52 cm (20.375 in) |

Table 13: Environmental specifications

| Characteristic | Description |
|----------------|---|
| Temperature | |
| Operating | +10 °C to +35 °C (50 °F to 95 °F), with 15 °C (59 °F)/hour maximum gradient, non condensing, derated 1 °C (34 °F) per 300 m (984 ft) above 1500 m (4921 ft) altitude |
| Nonoperating | -20 °C to +60 °C (-4 °F to 140 °F), with 30 °C (86 °F)/hour maximum gradient |
| Humidity | |
| Operating | 5% to 95% relative humidity at up to 30 °C (86 °F) 5% to 65% relative humidity above 30 °C (86 °F) up to 35 °C (95 °F), non condensing, limited by maximum wet-bulb temperature of 29 °C (84 °F), derates relative humidity to 65% at +35 °C (95 °F) |
| Nonoperating | 5% to 95% relative humidity at up to 30 °C (86 °F) 5% to 65% relative humidity above 30 °C (86 °F) up to 60 °C (140 °F), non condensing, limited by maximum wet-bulb temperature of 29 °C (84 °F), derates relative humidity to 12% at +60 °C (140 °F) |
| Altitude | |
| Operating | To 3000 m (9843 ft.) |
| Nonoperating | To 12,000 m (39,370 ft.) |

Index

A

About tab, 12
 accessories
 optional, 1
 standard, 1
 application software, 20

B

battery information, 22

C

calibration, 23
 cleaning
 exterior, 22
 flat panel display, 21
 clearance requirements, 2
 clock input
 Error Detector, 7
 clock output
 Pattern Generator, 6
 compliance
 optical transmitter, xiii
 connector replacement, 23
 connectors
 Error Detector, 7
 front panel, 5, 6, 7
 Pattern Generator, 6
 rear panel, 8, 9
 control buttons, 10
 Control console, 10
 conventions, xii

D

data input
 Error Detector, 7
 data output
 Pattern Generator, 6
 detector start input
 Error Detector, 9
 documentation, xii

E

electrostatic discharge, 2

environmental
 considerations, 2
 specifications, 24
 error blank input
 Error Detector, 7
 Error Detector
 clock input, 7
 data input, 7
 detector start input, 9
 error blank input, 7
 error output, 7
 front panel connectors, 7
 marker input, 7
 set up, 16
 synchronization problems, 18
 trigger output, 7
 error output
 Error Detector, 7
 ESD, 2
 external clock input
 Pattern Generator, 6

F

features and benefits, xi
 flat panel display
 cleaning, 21
 front panel
 connectors, 5, 6, 7
 front panel connectors
 Error Detector, 7
 Pattern Generator, 6
 fuse
 replacement, 23
 specifications, 2

H

high-frequency jitter input
 Pattern Generator, 6, 9
 Home view, 3, 10

K

key features, xi
 key specifications, xiv

L

Log tab, 12
 low-frequency sine jitter in
 Pattern Generator, 9
 low-frequency sine jitter out
 Pattern Generator, 9

M

maintenance
 cleaning, 21, 22
 preventive, 21
 manual
 conventions, xii
 marker input
 Error Detector, 7

O

on-screen controls, 10
 online help, xii
 operating requirements, 2
 operating system restore, 20
 optional accessories, 1
 options, xiv

P

packaging, 23
 page select
 Pattern Generator, 9
 Pattern Generator
 clock output, 6
 data output, 6
 external clock input, 6
 front panel connectors, 6
 high-frequency jitter input, 6, 9
 low-frequency sine jitter in, 9
 low-frequency sine jitter out, 9
 page select, 9
 pattern start input, 9
 reference in, 9
 reference out, 9
 set up, 13
 sine interference out, 9
 substrate clock, 6
 substrate clock output, 6
 synchronization problems, 18
 trigger output, 6

- pattern start input
 - Pattern Generator, 9
- power off procedure, 4
- power on procedure, 3
- power requirements, 2
- preventive maintenance, 21
- product options, xiv
- product overview, xiii

R

- rear panel
 - connectors, 8, 9
- reference in
 - Pattern Generator, 9
- reference out
 - Pattern Generator, 9
- Registry tab, 12
- repackaging, 23
- repair service, 21
- requirements
 - clearance, 2
 - operating, 2
 - power, 2
 - voltage, 2

S

- self test, 3, 12
- service offerings, 21
- Settings tab, 12

- shut down procedure, 4
- sine interference out
 - Pattern Generator, 9
- site considerations, 2
- specifications
 - altitude, 24
 - environmental, 24
 - fuse, 2
 - humidity, 24
 - key, xiv
 - PC-related, 24
 - physical, 24
 - temperature, 24
- standard accessories, 1
- static precautions, 2
- Status bar, 11
- substrate clock
 - Pattern Generator, 6
- substrate clock output
 - Pattern Generator, 6
- supported instruments, xiii
- synchronization problems, 18
- System view, 12
 - About tab, 12
 - Log tab, 12
 - Registry tab, 12
 - Self test tab, 12
 - Settings tab, 12
 - Tools tab, 12

T

- Tools tab, 12
- touch
 - defined, xii
- trigger output
 - Error Detector, 7
 - Pattern Generator, 6
- troubleshooting
 - operating system restore, 20
 - synchronization problems, 18

V

- VGA connector, 8
- view
 - defined, xii
- voltage
 - requirements, 2

W

- warranty service, 21