

H500 Spectrum Analyzer, SA2500 Spectrum Analyzer Service Manual



077-0786-01

Tektronix

**H500 Spectrum Analyzer,
SA2500 Spectrum Analyzer
Service Manual**

Copyright © Tektronix. All rights reserved. Licensed software products are owned by Tektronix or its subsidiaries or suppliers, and are protected by national copyright laws and international treaty provisions.

Tektronix products are covered by U.S. and foreign patents, issued and pending. Information in this publication supersedes that in all previously published material. Specifications and price change privileges reserved.

TEKTRONIX and TEK are registered trademarks of Tektronix, Inc.

NetTek is a registered trademark of Tektronix, Inc.

Contacting Tektronix

Tektronix, Inc.
14150 SW Karl Braun Drive
P.O. Box 500
Beaverton, OR 97077
USA

For product information, sales, service, and technical support:

- In North America, call 1-800-833-9200.
- Worldwide, visit www.tektronix.com to find contacts in your area.

Warranty

Tektronix warrants that this product will be free from defects in materials and workmanship for a period of one (1) year from the date of shipment. If any such product proves defective during this warranty period, Tektronix, at its option, either will repair the defective product without charge for parts and labor, or will provide a replacement in exchange for the defective product. Parts, modules and replacement products used by Tektronix for warranty work may be new or reconditioned to like new performance. All replaced parts, modules and products become the property of Tektronix.

In order to obtain service under this warranty, Customer must notify Tektronix of the defect before the expiration of the warranty period and make suitable arrangements for the performance of service. Customer shall be responsible for packaging and shipping the defective product to the service center designated by Tektronix, with shipping charges prepaid. Tektronix shall pay for the return of the product to Customer if the shipment is to a location within the country in which the Tektronix service center is located. Customer shall be responsible for paying all shipping charges, duties, taxes, and any other charges for products returned to any other locations.

This warranty shall not apply to any defect, failure or damage caused by improper use or improper or inadequate maintenance and care. Tektronix shall not be obligated to furnish service under this warranty a) to repair damage resulting from attempts by personnel other than Tektronix representatives to install, repair or service the product; b) to repair damage resulting from improper use or connection to incompatible equipment; c) to repair any damage or malfunction caused by the use of non-Tektronix supplies; or d) to service a product that has been modified or integrated with other products when the effect of such modification or integration increases the time or difficulty of servicing the product.

THIS WARRANTY IS GIVEN BY TEKTRONIX WITH RESPECT TO THE PRODUCT IN LIEU OF ANY OTHER WARRANTIES, EXPRESS OR IMPLIED. TEKTRONIX AND ITS VENDORS DISCLAIM ANY IMPLIED WARRANTIES OF MERCHANTABILITY OR FITNESS FOR A PARTICULAR PURPOSE. TEKTRONIX' RESPONSIBILITY TO REPAIR OR REPLACE DEFECTIVE PRODUCTS IS THE SOLE AND EXCLUSIVE REMEDY PROVIDED TO THE CUSTOMER FOR BREACH OF THIS WARRANTY. TEKTRONIX AND ITS VENDORS WILL NOT BE LIABLE FOR ANY INDIRECT, SPECIAL, INCIDENTAL, OR CONSEQUENTIAL DAMAGES IRRESPECTIVE OF WHETHER TEKTRONIX OR THE VENDOR HAS ADVANCE NOTICE OF THE POSSIBILITY OF SUCH DAMAGES.

[W2 – 15AUG04]

Table of Contents

| | |
|---|-----|
| Important safety information | iv |
| General safety summary | iv |
| Service safety summary | vi |
| Terms in this manual | vi |
| Symbols and terms on the product | vii |
| Preface | ix |
| Manual content | ix |
| Manual conventions | ix |
| Related user documents | x |
| Installation | 1 |
| Operating information | 2 |
| Performance verification | 3 |
| Preparation | 3 |
| Test record | 4 |
| Procedures | 6 |
| Test descriptions | 7 |
| Verify performance | 12 |
| Theory of operation | 23 |
| Instrument block diagram | 23 |
| Measurement module | 31 |
| Adjustment procedures | 33 |
| Cleaning | 35 |
| Removal and replacement procedures | 37 |
| Preparation | 37 |
| Preventing electrostatic damage | 38 |
| Removal procedures | 38 |
| Troubleshooting | 48 |
| Power on self test | 49 |
| Display does not operate | 49 |
| Display image inverted (Rotated 180°) | 50 |
| Touch screen does not operate | 50 |
| Signal and connector information | 50 |
| Lithium-Ion battery maintenance | 59 |
| H500 and SA2500 Instrument-Specific battery maintenance | 61 |
| Repackaging for shipment | 65 |
| Replaceable parts | 67 |
| Parts ordering information | 67 |
| Using the replaceable parts list | 67 |
| Specifications | 75 |

List of Figures

| | |
|--|----|
| Figure 1: Processor and backlight board input and output connections | 48 |
| Figure 2: Module and cover replaceable parts | 68 |
| Figure 3: Mainframe replaceable parts..... | 70 |
| Figure 4: H500 and SA2500 accessories | 73 |

List of Tables

| | |
|---|----|
| Table 1: DB- 9F serial loop-back connector pin-out | 10 |
| Table 2: Test voltages and limits..... | 11 |
| Table 3: External ports and buses..... | 26 |
| Table 4: Internal ports and buses | 26 |
| Table 5: Platform voltage supplies to module..... | 29 |
| Table 6: Tools required | 37 |
| Table 7: Backlight-related voltages..... | 49 |
| Table 8: Backlight-related voltages..... | 50 |
| Table 9: PCMCIA interface connectors JR420, JR520..... | 50 |
| Table 10: Application module connector JR170 | 51 |
| Table 11: Internal speaker connector J110..... | 53 |
| Table 12: External microphone connector J200..... | 53 |
| Table 13: Power connector J240..... | 53 |
| Table 14: Front-panel switch/LED connector J120..... | 54 |
| Table 15: Serial port connector J500 | 54 |
| Table 16: JTAG port connector J670 | 54 |
| Table 17: PS/2 keyboard connector J700 | 55 |
| Table 18: Headphone connector J300 | 55 |
| Table 19: TFT color display connector J660 | 55 |
| Table 20: TFT backlight inverter board, connector CN2 (Applies to instrument serial numbers B010000-B049999)..... | 56 |
| Table 21: TFT backlight power board, connector J2 (Applies to instrument serial numbers B050000 and higher)..... | 57 |
| Table 22: Touch screen connector J4 and J2 | 57 |
| Table 23: Ethernet connector J400 | 57 |
| Table 24: USB 1.1 series A host connector J701 | 58 |
| Table 25: USB 1.1 series B slave connector J800 | 58 |
| Table 26: Backlight connector JR1/J1..... | 58 |
| Table 27: General performance characteristics..... | 75 |
| Table 28: Spectrum analyzer characteristics..... | 77 |
| Table 29: DPX measurement processing characteristics..... | 79 |
| Table 30: Spectrogram (Rising Raster) measurement processing characteristics | 80 |
| Table 31: General purpose RF measurement characteristics | 80 |
| Table 32: Amplitude vs. Time measurement characteristics | 81 |
| Table 33: Signal analysis and monitoring characteristics | 82 |
| Table 34: Environmental characteristics | 83 |
| Table 35: Physical characteristics | 83 |
| Table 36: Miscellaneous characteristics | 83 |

Important safety information

This manual contains information and warnings that must be followed by the user for safe operation and to keep the product in a safe condition.

To safely perform service on this product, additional information is provided at the end of this section. (See page vi, *Service safety summary*.)

General safety summary

Use the product only as specified. Review the following safety precautions to avoid injury and prevent damage to this product or any products connected to it. Carefully read all instructions. Retain these instructions for future reference.

Comply with local and national safety codes.

For correct and safe operation of the product, it is essential that you follow generally accepted safety procedures in addition to the safety precautions specified in this manual.

The product is designed to be used by trained personnel only.

Only qualified personnel who are aware of the hazards involved should remove the cover for repair, maintenance, or adjustment.

Before use, always check the product with a known source to be sure it is operating correctly.

This product is not intended for detection of hazardous voltages.

Use personal protective equipment to prevent shock and arc blast injury where hazardous live conductors are exposed.

When incorporating this equipment into a system, the safety of that system is the responsibility of the assembler of the system.

To avoid fire or personal injury

Use proper power cord. Use only the power cord specified for this product and certified for the country of use.

Do not use the provided power cord for other products.

Ground the product. This product is grounded through the grounding conductor of the power cord. To avoid electric shock, the grounding conductor must be connected to earth ground. Before making connections to the input or output terminals of the product, make sure that the product is properly grounded.

Do not disable the power cord grounding connection.

Power disconnect. The power cord disconnects the product from the power source. See instructions for the location. Do not position the equipment so that

it is difficult to operate the power cord; it must remain accessible to the user at all times to allow for quick disconnection if needed.

Use proper AC adapter. Use only the AC adapter specified for this product.

Observe all terminal ratings. To avoid fire or shock hazard, observe all ratings and markings on the product. Consult the product manual for further ratings information before making connections to the product.

Do not apply a potential to any terminal, including the common terminal, that exceeds the maximum rating of that terminal.

The measuring terminals on this product are not rated for connection to mains or Category II, III, or IV circuits.

Do not operate without covers. Do not operate this product with covers or panels removed, or with the case open. Hazardous voltage exposure is possible.

Avoid exposed circuitry. Do not touch exposed connections and components when power is present.

Do not operate with suspected failures. If you suspect that there is damage to this product, have it inspected by qualified service personnel.

Disable the product if it is damaged. Do not use the product if it is damaged or operates incorrectly. If in doubt about safety of the product, turn it off and disconnect the power cord. Clearly mark the product to prevent its further operation.

Examine the exterior of the product before you use it. Look for cracks or missing pieces.

Use only specified replacement parts.

Replace batteries properly. Replace batteries only with the specified type and rating.

Recharge batteries properly. Recharge batteries for the recommended charge cycle only.

Use proper fuse. Use only the fuse type and rating specified for this product.

Do not operate in wet/damp conditions. Be aware that condensation may occur if a unit is moved from a cold to a warm environment.

Do not operate in an explosive atmosphere.

Keep product surfaces clean and dry. Remove the input signals before you clean the product.

Provide proper ventilation. Refer to the installation instructions in the manual for details on installing the product so it has proper ventilation.

Slots and openings are provided for ventilation and should never be covered or otherwise obstructed. Do not push objects into any of the openings.

Provide a safe working environment. Always place the product in a location convenient for viewing the display and indicators.

Avoid improper or prolonged use of keyboards, pointers, and button pads. Improper or prolonged keyboard or pointer use may result in serious injury.

Be sure your work area meets applicable ergonomic standards. Consult with an ergonomics professional to avoid stress injuries.

Service safety summary

The *Service safety summary* section contains additional information required to safely perform service on the product. Only qualified personnel should perform service procedures. Read this *Service safety summary* and the *General safety summary* before performing any service procedures.

To avoid electric shock. Do not touch exposed connections.

Do not service alone. Do not perform internal service or adjustments of this product unless another person capable of rendering first aid and resuscitation is present.

Disconnect power. To avoid electric shock, switch off the product power and disconnect the power cord from the mains power before removing any covers or panels, or opening the case for servicing.

Use care when servicing with power on. Dangerous voltages or currents may exist in this product. Disconnect power, remove battery (if applicable), and disconnect test leads before removing protective panels, soldering, or replacing components.

Verify safety after repair. Always recheck ground continuity and mains dielectric strength after performing a repair.

Terms in this manual

These terms may appear in this manual:



WARNING. *Warning statements identify conditions or practices that could result in injury or loss of life.*



CAUTION. *Caution statements identify conditions or practices that could result in damage to this product or other property.*

Symbols and terms on the product

These terms may appear on the product:

- DANGER indicates an injury hazard immediately accessible as you read the marking.
- WARNING indicates an injury hazard not immediately accessible as you read the marking.
- CAUTION indicates a hazard to property including the product.



When this symbol is marked on the product, be sure to consult the manual to find out the nature of the potential hazards and any actions which have to be taken to avoid them. (This symbol may also be used to refer the user to ratings in the manual.)

The following symbol(s) may appear on the product:



CAUTION
Refer to Manual



Standby

Preface

This service manual is for servicing the H500 and SA2500 Spectrum Analyzers.

Manual content

This manual contains information related to servicing the mainframe part of the H500 and SA2500 Spectrum Analyzers, and running a performance verification on the whole instrument. The module part of the instrument has no user-serviceable parts or adjustments. The entire instrument must be returned to Tektronix if service is required.

For information related to installing and operating the instrument, or for a list of instrument specifications, refer to the appropriate user document as described in *Related User Documents* below.

Be sure to read the introductions to all procedures. These introductions provide important information needed to perform the service correctly, safely, and efficiently.

Manual conventions

This manual uses certain conventions that you should become familiar with before attempting service.

- | | |
|--------------------------|--|
| Module | The term module refers to a collection of items that are replaceable as a unit. A module may contain electrical and mechanical assemblies, circuit boards, and interconnecting cables. |
| Replaceable parts | This manual refers to any field-replaceable assembly or mechanical part by its name or generically as a replaceable part. In general, a replaceable part is any circuit board or assembly that is listed in the Replaceable Parts section. |
| Safety | Symbols and terms related to safety appear in the General Safety Summary found at the beginning of this manual. Be sure to read both the General Safety Summary and Service Safety Summary before performing any service to this instrument. |

Related user documents

The following related English user documents are available if you need more information about operating the instrument. The user manuals can be downloaded from the Tektronix Web site (www.tektronix.com).

- User manual. Tektronix part number 071-3115-xx (for the H500) and Tektronix part number 071-3118-xx (for the SA2500) contain general information about how to put the instrument into service, guides to user interface controls, and application examples.
- Application Help. The H500 and SA2500 Spectrum Analyzer applications contain help files that are context sensitive, displaying information appropriate for the active screen or the selected help button.

Installation

The Specifications section contains information on instrument operation environment requirements. (See Table 34 on page 83.)

Operating information

Refer to the instrument user manual for operation instructions.

Performance verification

This section enables you to verify that the instrument performs according to its warranted characteristics.

Preparation

Before you perform the procedures in this manual, do the following steps:

- Ensure that the procedures are performed only by qualified service personnel who have read the *General Safety Summary* at the front of this manual.
- Ensure that the service personnel are familiar with system operation (refer to the product user manual).

Obtain the equipment described in the following table. You may also need additional cables and adapters, depending on the actual test equipment you use.

| Description | Minimum requirements | Examples |
|---|---|---|
| Signal generator | 0.009 to 6200 MHz, phase noise better than -110 dBc/Hz at 10 kHz offset | Anritsu MG3692B with option 22 (low frequency), option 3 (low phase noise, main band), and option 4 (low phase noise, low band) |
| Frequency standard | 10 MHz (or any frequency in the range 1 MHz to 20 MHz in 1 MHz increments), ± 0.05 ppm | Fluke 910/910R GPS Controlled Frequency Standards |
| Power meter with head | 0.009 to 6200 MHz, -52 dBm to +3 dBm | Agilent E4418B Agilent E9304A |
| Oscilloscope | 300 MHz bandwidth | Tektronix TDS3034B |
| 10 dB fixed attenuator | 0.009 to 6200 MHz | RLC Electronics A-8-10-N |
| 50 ohm N-type RF cable | 0.009 to 6200 MHz | Florida RF Labs NMS - 290 AN - 36.0 - NMS |
| 50 ohm BNC cables | None | Tektronix part number 012-0482-00 |
| N-type barrel female-to-female adapter | 0.009 MHz to 6200 MHz | SRI Connector Gage Co. P/N 53-953-0003-00 |

Test record

| Serial number | Procedure performed by | Date |
|---------------|------------------------|------|
|---------------|------------------------|------|

| Test | Passed | Failed |
|------|--------|--------|
|------|--------|--------|

| | | |
|-----------|--|--|
| Self Test | | |
|-----------|--|--|

| Performance checks | | Low limit | Test result | High limit |
|---|---------------------------------|------------------------|-------------|------------|
| Carrier Frequency and Timebase Error | Tested at 6 GHz | -3010 Hz ¹ | | 3010 Hz |
| | | -9010 Hz ² | | 9010 Hz |
| | | -15010 Hz ³ | | 15010 Hz |
| External Lock Time | 10 MHz (typical) Reference Freq | - | | 15 s |
| RF Channel Power Accuracy | 50 MHz, -5 dBm Input | -1.2 dB | | +1.2 dB |
| | 3200 MHz, -5 dBm Input | -1.2 dB | | +1.2 dB |
| | 5000 MHz, -5 dBm Input | -1.8 dB | | +1.8 dB |
| | 6199 MHz, -5 dBm Input | -1.8 dB | | +1.8 dB |
| | 50 MHz, -20 dBm Input | -1.2 dB | | +1.2 dB |
| | 3200 MHz, -20 dBm Input | -1.2 dB | | +1.2 dB |
| | 5000 MHz, -20 dBm Input | -1.8 dB | | +1.8 dB |
| | 6199 MHz, -20 dBm Input | -1.8 dB | | +1.8 dB |
| | 50 MHz, -35 dBm Input | -1.2 dB | | +1.2 dB |
| | 3200 MHz, -35 dBm Input | -1.2 dB | | +1.2 dB |
| | 5000 MHz, -35 dBm Input | -1.8 dB | | +1.8 dB |
| | 6199 MHz, -35 dBm Input | -1.8 dB | | +1.8 dB |
| Phase Noise | 100 MHz Input, 10 kHz, offset | - | | -95 dBc/Hz |
| | 3000 MHz Input, 10 kHz offset | - | | -95 dBc/Hz |
| | 5000 MHz Input, 10 kHz offset | - | | -95 dBc/Hz |
| | 6000 MHz Input, 10 kHz offset | - | | -95 dBc/Hz |
| Displayed Average Noise Level | 1 MHz to 4 GHz ¹ | | | -153 dBm |
| | 2 GHz to 4 GHz | | | -152 dBm |
| | 4 GHz to 5 GHz | | | -151 dBm |
| | 5 GHz to 6.2 GHz | | | -145 dBm |
| Residual Spurious, Preamp On ⁴ | -60 dBm ref level | | | -105 dBm |

¹ Use this limit if testing shortly after instrument calibration.

² Use this limit if testing one year after instrument calibration.

³ Use this limit if testing two years after instrument calibration.

⁴ The following are exception frequencies (not warranted to specification):

9 MHz to 19 MHz center frequency

5374 MHz to 5378 MHz center frequency

Instrument warmup

Before performing these procedures, the following equipment must have been operating continuously for at least twenty (20) minutes in an environment that meets the operating range specifications for temperature and humidity:

- The H500 or SA2500 under test
- All test equipment

Equipment setup

Setup the test equipment as follows:

1. Reset all the test instruments to their factory default settings before starting a test.
2. Connect the RF cable to the output of the Signal Generator; all test instructions make this assumption.
3. Connect the AC adapter to the H500 or SA2500 instrument. Do not attempt to do the procedure steps while the instrument is powered from the batteries.

Procedures

A test record table is provided. (See page 4, *Test record*.) You can photocopy the page and record your test results in the table.

Diagnostic tests

This section contains procedures to verify that the instrument is functioning properly.

1. Select **Start > Programs > Tektronix Utilities > Diagnostics**.
2. Tap the **Diagnostics** tab.
3. To view the test selections, tap the + symbol in front of **All Modules, All Tests**. Then tap the + symbol in front of **Platform**.

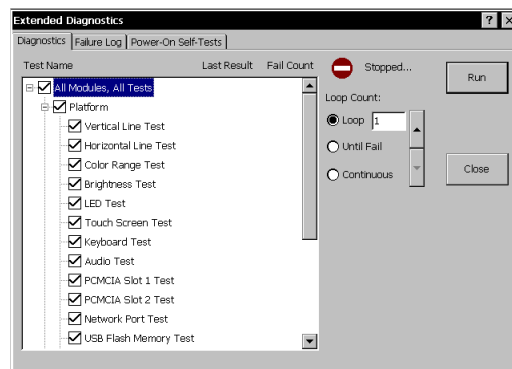

4. Select the test(s) to run. The default selection runs all tests. However, some diagnostic tests require special equipment or custom fixtures (such as a DB-9F serial loopback connector, PCMCIA ATA flash memory cards, PS/2-compatible keyboard, Microphone, USB Flash Memory Device, and a network interface connected to a DHCP-enabled network server). Clear the box next to any test that requires equipment or custom fixtures that you do not have available for the tests, otherwise these tests will indicate that they fail.
5. Select one of the test run options:
 - **Loop**. Use the up/down arrows to set how many times to repeat the test(s).
 - **Until Fail**. Run the selected test(s) until a failure occurs or the user selects Stop.
 - **Continuous**. Run the selected test(s) until the user selects Stop.
6. Tap **Run** to begin the tests.

Test Results Reporting. The Diagnostics window contains columns and fields to report the results of each test.

- The **Last Result** column lists the Pass or Fail status of each test.
- The **Fail Count** column lists the number of times a test failed.
- The **Loop Count** field reports the number of times the test ran.

To see details on failed tests, select the **Failure Log** tab and read the **Message** column.

Test descriptions

Some diagnostic tests require special equipment or custom fixtures. These requirements are noted under each description.

Vertical Line Test

Observe a full screen of moving vertical lines.

1. Look for inconsistent line widths and lengths.
2. Report a Pass or Fail when prompted.

A Test failed is recorded in the Failure Log if the user does not enter a pass/fail response when prompted.

Horizontal Line Test

Observe a full screen of moving horizontal lines.

1. Look for inconsistent line widths and lengths.
2. Report a Pass or Fail.

A Test failed is recorded in the Failure Log if the user does not enter a pass/fail response when prompted.

Color Range Test

Observe two different color test patterns.

1. Pattern 1, look for color fading and inconsistencies while observing red, green, and blue color bands on a white background.
2. Pattern 2, look for color inconsistencies (failed pixels) while observing three different full color screens (red, green, blue).
3. Report a Pass or Fail when prompted.

A Test failed is recorded in the Failure Log if the user does not enter a pass/fail response when prompted.

Brightness Test Observe a full screen checkerboard pattern that changes brightness.

1. Look for adequate brightness at each level.
2. Report a Pass or Fail when prompted.

A Test failed is recorded in the Failure Log if the user does not enter a pass/fail response when prompted.

The display returns to its original brightness at test completion.

LED Test Observe a series of front-panel LED color cycles.

1. Look for the color and position indicated: left-right, green, red, and amber.
2. Report a Pass or Fail when prompted.

A Test failed is recorded in the Failure Log if the user does not enter a pass/fail response when prompted.

Touch Screen Test Observe a crosshair cursor that moves from screen center to top-left, top-right, bottom-right, and bottom-left.

1. At each position, press on the center of the crosshair icon until it moves.
Use the stylus or your finger.

Pass is reported if the sequence is completed within the allotted time.

Test failed is recorded in the Failure Log if no user interaction is detected or the user presses outside of the crosshair area.

Keyboard Test Check the keyboard cable connection to the instrument; check the function of each key.

NOTE. *This test requires an external PS/2 keyboard.*

1. Connect a PS/2-compatible keyboard to the keyboard port. Refer to the user manual for port location.
2. Select **Keyboard Test**; then select **Run**.
3. Enter the requested text on the keyboard when prompted; then select OK.

The text must be duplicated exactly or the test will fail.

This test reports a Fail if a keyboard is not connected or the user misspells the message.

Audio Test Check the external microphone and speaker operation.

1. Plug a microphone into the external microphone jack.
2. Select **Audio Test**; then select **Run**.
3. When prompted, speak into the microphone for approximately 5 seconds.
The device will then automatically play back your message.
4. Listen to the playback and verify its accuracy. The test fails if there is no output or if the audio is significantly distorted.
5. Report a Pass or Fail when prompted.

A Test failed is recorded in the Failure Log if the user does not enter a pass/fail response when prompted.

PCMCIA Slot 1 Test Check the PCMCIA controller connection to an ATA flash card in Slot 1. The test uses standard API functions to create a file on the device, write data to the file, read the file back, and validate the data.

NOTE. *This test requires two PCMCIA ATA flash memory cards. Both cards must be installed for the test to run successfully.*

1. Install two PCMCIA ATA flash memory cards, one in each of the PCMCIA card slots.
2. Select **PCMCIA Slot 1 Test**, then tap **Run**.

A Test failed is recorded in the Failure Log if a memory card is not installed when prompted.

PCMCIA Slot 2 Test Check the PCMCIA controller connection to an ATA flash card in Slot 2. Uses standard API functions to create a file on the device, write data to the file, read the file back, and validate the data.

NOTE. *NOTE. This test requires two PCMCIA ATA flash memory cards. Both cards must be installed for the test to run successfully.*

1. Install two PCMCIA ATA flash memory cards in the PCMCIA card slots.
2. Select **PCMCIA Slot 2 Test**; then select **Run**.

A Test failed is recorded in the Failure Log if a memory card is not installed when prompted.

Network Port Test Checks the Ethernet network port. Requires a network connection with a DHCP server.

1. Connect the RJ45 Ethernet port to a DHCP-enabled network server.
2. Select **Network Port Test**; then select **Run**.

A Test failed is recorded in the Failure Log if the NetTek Analyzer cannot obtain an I.P. address from the DHCP-enabled network server.

Serial Port Test Check the serial port signal lines by setting the output control lines and reading the corresponding status lines. Writes, reads, and validates a data pattern at varying baud rates.

NOTE. *This test requires a custom DB-9F serial loop-back connector.*

Table 1: DB- 9F serial loop-back connector pin-out

| Connect pin | To pin |
|-------------|---------|
| 1 (DCD) | 4 (DTR) |
| 6 (DSR) | 4 (DTR) |
| 2 (RX) | 3 (TX) |
| 5 (SGND) | NC |
| 8 (CTS) | 7 (RTS) |
| 9 (RI) | 7 (RTS) |

1. Install the custom DB-9 loop-back connector on the RS-232 serial port. Refer to the user manual for port location.
2. Select **Serial Port Test**; then select **Run**.

A Test failed is recorded in the Failure Log if the loop-back connector is not installed when prompted.

USB Flash Memory Device Test

Tests the USB port using a Flash Memory drive.

NOTE. *This test requires a USB Flash Memory Device inserted into the USB slot.*

If a Flash Memory Device is not installed when the test is initiated, the user is prompted to insert a Flash Memory Drive or fail the test. The test consists of the following:

- Creating a data file
- Writing a fixed size pattern to the file
- Closing the file

If an error occurs during any portion of the test, the test terminates and reports a Test failed in the Failure Log. A Test failed is also recorded if a Flash Memory Drive is not installed when prompted.

SPI Test

Check the external connectivity and function by setting the instrument module interface port to loop back mode and sending, receiving, and validating device selects and frequency changes.

No user interaction required. Select **Run**.

SMBus Test

Verify communications between the host and power management processor.

No user interaction required. Select **Run**.

Flash File System Test

Check the read/write function and data integrity of the internal flash file system. The test uses standard API functions to create a file, write a data pattern to the file, read the file, and validate the data.

Power Test

Verify the instrument processor board and application module voltages are within their nominal range. See Table 3-2 for voltage limits.

NOTE. *The Power Test does not check battery voltages.*

This test uses internal voltage sensing. No user interaction required. Select **Run**.

Table 2: Test voltages and limits

| Source | Voltage (V _{DC}) | Limits (V _{DC}) |
|-----------------|----------------------------|---------------------------|
| Processor board | +1.5 | 10% |
| Processor board | +3.3 | 10% |

Table 2: Test voltages and limits (cont.)

| | | |
|--------------------|------|-----|
| Processor board | +5 | 10% |
| Application module | +3.4 | 10% |
| Application module | +13 | 10% |
| Application module | -13 | 10% |

This test reports a fail if the detected voltages exceed $\pm 10\%$ of their nominal values.

Verify performance

Before continuing these procedures, warm up the instrument and all other test equipment for at least twenty (20) minutes in an environment that meets the operating range specifications for temperature and humidity.

To warm up the instrument:

1. Connect the AC adapter to the H500 or SA2500 instrument. Do not attempt to do the procedure steps while powered from the batteries.
2. Power on the instrument. Wait until it completes the power-on sequence.
3. Double-tap the H500 or SA2500 application icon on the screen to open and run the instrument application. Leave the application running.

Check carrier frequency and time-base

This test checks the accuracy of the carrier frequency measurement and the accuracy of its internal time-base.

1. Remove any cable attached to instruments Freq Ref BNC.
2. Reset the instrument application:
 - a. Select **Tools > Factory Reset**.
 - b. Tap **Reset All**.
3. Connect the Signal Generator output to the H500 under test **RF INPUT** connector through the RF cable.
4. Set the Signal Generator as follows:
 - a. Reset the Signal Generator.
 - b. Connect the Frequency Standard output to the frequency reference input of the Signal Generator marked **REF**.
 - c. Set the Signal Generator lock to the external reference input.
 - d. Verify that the Signal Generator displays **is locked to the external reference**.

- e. Set frequency to **6 GHz**.
- f. Set the amplitude to **10 dBm**.
5. On the H500 or SA2500 application:
 - a. Tap the **Spectrum** drawer.
 - b. Tap the **Freq** button to open the Meas Freq form and enter **6 GHz**.
 - c. Tap the **Auto Level** button.
 - d. If you don't see the signal, tap on the **Span:** field right arrow button to increase the signal span.
 - e. Tap the Meas Freq marker readout box just above the Start button to ensure the red triangle is the selected marker; the red triangle will be displayed on the marker button in the Spectrum drawer.
 - f. Using the marker drop-down box in the Spectrum drawer, select "Marker to max peak" then select "Marker to center freq".
 - g. Reduce the displayed signal span by tapping the arrow icon on the left of the **Span:** field.
 - h. Repeat steps g through h until the signal peak is centered in the display and the span is **0.010 MHz**.
 - i. Read the marker frequency value from the Meas Freq marker readout box.
 - j. Write down the **FREQ:** measurement.
 - k. Subtract **6 GHz** from the measured frequency. Check that the result is within the limits listed in the Test Record.

Check external lock time

This test checks the lock time of the external frequency reference input.

1. Reset the H500 or SA2500 application:
 - a. Select **Tools > Factory Reset**.
 - b. Tap **Reset All**.
2. On the Signal Generator:
 - a. RESET the Signal Generator.
 - b. Connect a BNC cable to the external reference output of the Signal generator.
3. On the H500 or SA2500:
 - a. Make sure that the reference oscillator indicator, near the upper right corner of the screen, is indicating **F Int**.
 - b. Connect the BNC cable from the signal generator's **10 MHz Reference Out** to the H500 **FREQUENCY REFERENCE INPUT** and record the time.
 - c. Watch the reference oscillator indicator; when it changes from **F Int** to **F Ext**, record the time.
 - d. The difference between the two times is the result of the test. The time should be 15 seconds or less.

Check RF channel power accuracy

This test checks the accuracy of the RF channel power measurement.

1. Reset the H500 or SA2500 application:
 - a. Select **Tools > Factory Reset**.
 - b. Tap **Reset All**.
2. Set the H500 or SA2500 application to read channel power:
 - a. Display a Spectrum measurement.
 - b. Tap the **RF Measure** drawer.
 - c. Select **Channel Power** from the **Measurement** drop-down list, tap the **Meas BW** field, tap the **keypad** icon on the **Meas BW** dialog box, and enter **10 kHz**.
3. Connect a 10 dB attenuator to the RF cable. (The attenuator improves the impedance match between the Signal Generator and the H500/SA2500 under test.)
4. Connect an N-type barrel adapter (female-to-female) to the attenuator.

5. Set the Signal Generator as follows:
 - a. Reset the Signal Generator.
 - b. Set the frequency to **50 MHz**.
 - c. Set the output level to **+5 dBm**.
6. Push the **ZERO** button on the power meter.
7. Connect the power meter head to the barrel adapter.
8. Perform a power measurement using the power meter:
 - a. Set the power meter correction factor for **50 MHz**.
 - b. Read the power.
9. Adjust the output level of the Signal Generator until the power meter reads **-5 dBm**.
10. Disconnect the power meter head and the barrel adapter from the cable/10 dB attenuator assembly.
11. Connect the RF cable with the 10 dB attenuator to the **RF INPUT** of the H500 or SA2500 under test.
12. On the H500 or SA2500:
 - a. Tap the **Freq** button to open the **Meas Freq** dialog and enter **50 MHz**.
 - b. If you don't see the signal, tap on the **Span:** field right arrow button to increase the signal span.
 - c. Tap the **Auto Level** button.
 - d. Tap the Meas Freq marker readout box (just above the Windows CE **Start** button) to set the red measurement triangle as the selected (active) marker. The red triangle will be displayed on the Marker-To button in the Spectrum drawer.
 - e. Tap the **Spectrum** drawer button.
 - f. Tap the down arrow button next to the Marker-To button and select **Marker to max peak**. Then select **Marker to center freq** to move the peak of the test signal to the center of the display.
 - g. Reduce the displayed signal span by tapping the arrow icon on the left of the **Span:** field.
 - h. Repeat steps f through g until the signal peak is centered in the display and the span is **10 kHz**.
 - i. Read the Channel Power in dBm; the Channel Power is displayed in the trace area if the Spectrum drawer is open or displayed on the Channel Power tab if the RF Measure drawer is open.

- j. Subtract the nominal power (-5 dBm) from the measurement value and write it down in the Test Record; this is the result of the test.
 - k. Disconnect the RF cable with the 10 dB attenuator from the **RF INPUT** of the H500 or SA2500 under test.
13. Repeat steps 3 through 12 for all frequencies and levels listed in the Test Record.

Check phase noise

This test determines the phase noise of the H500 or SA2500 under test. The Signal Generator used in the test should have significantly less phase noise than the H500 or SA2500 under test.

NOTE. *The peak detector is used to measure narrowband signals such as the CW signal from the signal source and the average detector is used to measure wideband signals such as noise floor.*

Signal generator setup.

1. Reset the signal generator.
2. Set the frequency to **100 MHz** (center frequency).
3. Set the output power level to **+10 dBm**.
4. Connect the RF cable from the signal generator output to the H500 or SA2500 under test **RF INPUT** connector.

H500/SA2500 setup.

1. Disconnect the cable from the H500/SA2500 **FREQ REF** connector if present.
2. Select **Tools > Factory Reset**
3. Tap **Reset All**.

Phase noise verification.

Do the following steps from the H500/SA2500:

1. Tap the **Spectrum** drawer.
2. Tap the **More** button in the Spectrum drawer.
3. Tap the **Freq/Span** tab and set **Span** to **100.000 kHz** and **Center Freq** to **100.000 MHz**.

4. Tap the **Trace** tab and set the following:
 - **Type** to **Average**
 - **Number of Averages** to **20** (default)
 - **Detector** to **+Peak**
5. Tap the **AutoLevel** button.
6. Tap the Meas Freq marker readout box (just above the Windows CE **Start** button) to set the red measurement triangle as the selected (active) marker. The application also updates the Marker-To button in the Spectrum drawer to show the red measurement triangle icon, indicating that the Marker-To button will act on the Meas Freq marker.
7. Tap the down arrow button next to the Marker-To button and select **Marker to max peak**. Then tap the down arrow button next to the Marker-To button again and select **Marker to center freq** to move the peak of the test signal to the center of the display.
8. Verify that the Span is still **100 kHz** and the Meas Freq marker box and center frequency readouts are both **100 MHz**.
9. Write down the level of the signal as shown in the Meas Freq marker readout box; this is the carrier level value L_c .
10. Tap the **Trace** tab and set the following:
 - **Type** to **Average**
 - **Number of Averages** to **100**
 - **Detector** to **Avg (V_{RMS})**
11. Write down the center frequency.
12. Tap the **M1** marker readout box on the bottom of the screen to open the M1 input control.
13. Tap the keypad icon in the **M1** control and enter the center frequency minus 10 kHz (offset). For example, a minus 10 kHz offset for 100 MHz is 99.990 MHz.
14. Tap the **M2** marker readout box on the bottom of the screen to open the M2 input control.
15. Tap the keypad icon in the **M2** control and enter the center frequency plus 10 kHz (offset). For example, a plus 10 kHz offset for 100 MHz is 100.010 MHz.

16. Determine the total sideband noise level:

- a. Tap the **Reset** display-control button (the **X** button located along the right side of the waveform plot) to reset the measurement, then wait until the instrument averages the 100 measurements.
- b. Write down the **M1** marker value; this is the lower sideband noise level LN_{ssb1} .
- c. Write down the **M2** marker value; this is the upper sideband noise level LN_{ssb2} .

17. Determine the noise floor levels:

- a. Turn off the signal generator.
- b. Tap the **Reset** display-control button (the **X** button located along the right side of the waveform plot) to reset the measurement, then wait until the instrument averages the 100 measurements.
- c. Write down the **M1** marker value; this is the lower sideband noise floor LNF_{ssb1} .
- d. Write down the **M2** marker value; this is the upper sideband noise floor LNF_{ssb2} .

18. Obtain the signal generator phase noise level at 10 kHz offset for 100 MHz output (LN_{sg}). This may be the typical phase noise performance stated in the signal generator user manual or specification sheet, or it may be the actual measured phase noise data for the signal generator. The signal generator's guaranteed specification limit should not be used since that may lead to an underestimate of the H500 or SA2500 phase noise.

For the Agilent signal generator shown in the Required Equipment list, use the following values for the signal generator phase noise level LN_{sg} :

- 100 MHz: -143 dBc
- 3 to 6 GHz: -113 dBc

19. Write down the Resolution Bandwidth displayed in the Spectrum drawer below **RBW, in Hz. Use this RBW value, and values obtained earlier in this procedure, to calculate the phase noise by using the following formulas:**

$$L_{ssb1} = 10 \times \log \left(10^{(LN_{ssb1}/10)} - 10^{(LNF_{ssb1}/10)} \right)$$

$$L_{ssb2} = 10 \times \log \left(10^{(LN_{ssb2}/10)} - 10^{(LNF_{ssb2}/10)} \right)$$

$$PN_1 = \frac{L_{ssb1} + L_{ssb2}}{2} - L_c - 10 \times \log_{10} (\text{RBW}) \text{ [in dBc/Hz]}$$

$$\text{Phase Noise} = 10 \times \log \left(10^{(PN_1/10)} - 10^{(LN_{sg}/10)} \right) \text{ [in dBc/Hz]}$$

20. Verify that the phase noise is less than -95 dBc/Hz.
21. Repeat Phase Noise Verification steps 1 through 20, readjusting the signal generator for all center frequencies noted in the Test Record.

Check GPS function

This test determines if the H500 or SA2500 built-in GPS functions properly.

NOTE. *The GPS antenna should be placed so that it has an unobstructed view of the sky. If the antenna is inside a building, it may not be able to locate any GPS signals due to signal attenuation caused by the building.*

1. Reset the H500 or SA2500 application:
 - a. Select **Tools > Factory Reset**.
 - b. Tap **Reset All**.
2. Connect the GPS antenna to the **GPS** connector on the instrument and position the antenna so that it has a clear view of the sky.
 - a. Tap the **GPS** button on the main screen.
 - b. Roll down the menu and select **Tek Internal GPS** from the **GPS Receiver** drop-down list.
 - c. Wait until five or more green bars show in the **Satellite Signal Strength** window.
 - d. Check that the GPS Lock icon turns green.
 - e. Check that the **Satellites in Use** status field readout is ≥ 5 .

Check displayed average noise level (DANL)

This test checks the H500 or SA2500 DANL with 10 Hz RBW (resolution bandwidth).

NOTE. *The DANL measurement is a measure of average noise and does not include spurious signals. If the marker is placed on a spurious signal, it should be moved slightly to the left or right to avoid the spurious signal.*

1. Reset the H500 or SA2500 application:
 - a. Select **Tools > Factory Reset**.
 - b. Tap **Reset All**.
2. Connect a 50 Ω RF terminator to the H500 or SA2500 under test **RF INPUT** connector. Disconnect the external reference.
 - a. Tap the **Freq** button and enter **1000 MHz**.
 - b. Set the **SPAN** to **10 kHz**.
 - c. Set the Ref Level to **-60 dBm**.
 - d. Tap the **Spectrum** drawer.
 - e. Tap the **More** button.
 - f. Tap the **Trace** tab.
 - g. Change the detector to **Average** mode.
 - h. Select **Average** from the **Trace 1 type:** drop-down men.
 - i. Tap the **x** button to close the tabs.
 - j. Place a marker near the center frequency and read the marker dBm value. If the marker is on a spurious signal, the marker should be moved slightly to the left or right to avoid the spurious signal. Record this value in the test record.
3. Change the **Freq** to **3200 MHz**, **5000 MHz** and **6199 MHz** and repeat step j.

Check residual spurs

This test checks for residual spur signals with the preamp on. Because this is a manual test, it is simplified to look for gross defects instead of a more rigorous check.

1. Reset the H500 or SA2500 application:
 - a. Select **Tools > Factory Reset**.
 - b. Tap **Reset All**.
2. Connect a 50 Ohm RF terminator to the H500 or SA2500 under test **RF INPUT** connector. Disconnect the external reference.
 - a. Tap the **Spectrum** drawer.
 - b. Tap the **More** button.
 - c. Tap the **Trace** tab.
 - d. Change **Type** to **Average**.
 - e. Change the detector to **Average** mode.
 - f. Tap the **Ampl** tab.
 - g. Set the **Ref Level** to **-60 dBm**.
 - h. Tap the **Freq/Span** tab.
 - i. Set the **Start** frequency to **10 MHz**.
 - j. Set the **Stop** frequency to **6200 MHz**.
 - k. Set the **RBW** to **100 KHz**.
3. Note any single frequencies that extend more than about 5 dB above the adjacent noise floor.
 - a. For any single frequencies found, adjust the span and center frequency to reduce the span to 20 MHz centered around the suspect frequency.
 - b. If this single frequency exceeds the residual spur high limit of the test record, write the frequency and amplitude of this spur in the test record.
 - c. Repeat steps a and b for any other suspect frequencies.

End of performance verification procedures.

Theory of operation

This section of the manual describes the base instrument theory of operation. As the instrument measurement module is not user-serviceable, there is no theory of operation for the module.

Instrument block diagram

Refer to the following figure while reading this section.

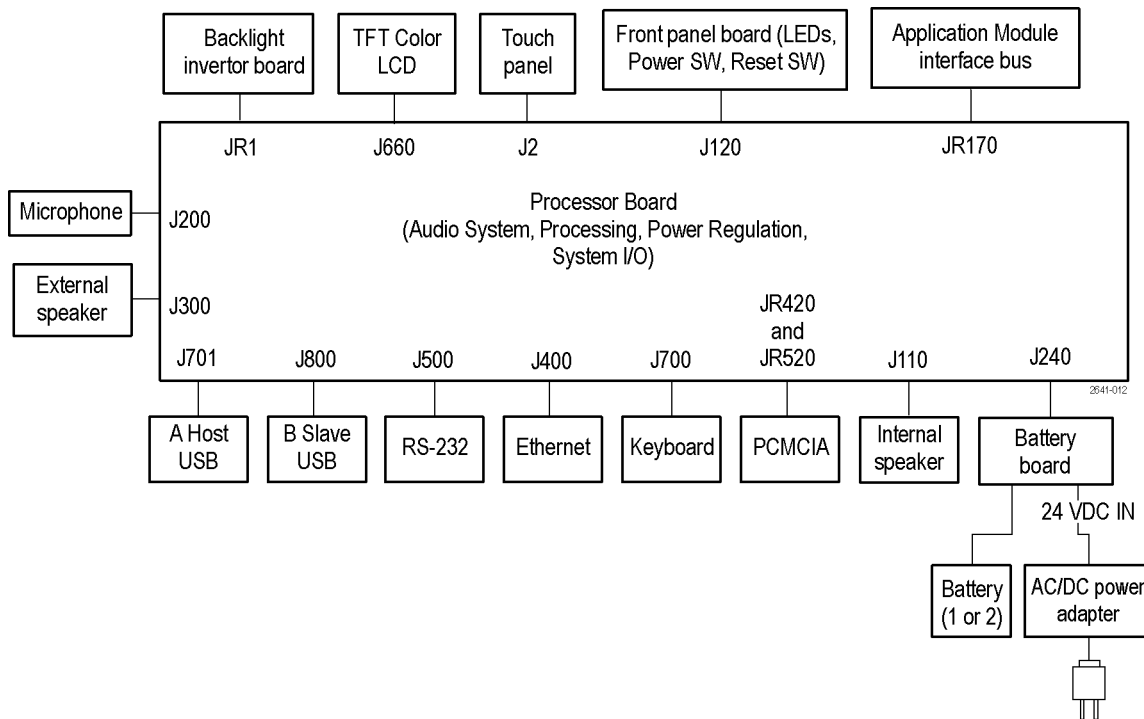

Display (Serial number B010000 to B049999)

The color display is a TFT type transfective with backlight. The display inverter is implemented on the Processor board. The color display has the following characteristics:

10.4 inch diagonal size, 640 x 480 resolution, 256-color display.

Transfective backing for indoor and outdoor viewability.

Power consumption: logic 1.98 W, backlight: 5.76 W (dual cold cathode fluorescent lamps) from backlight inverter board.

Display (Serial number B050000 onward)

The color display is a TFT type transfective with backlight. The display inverter is implemented on the Processor board. The color display has the following characteristics:

10.4 inch diagonal size, 640 x 480 resolution, 256-color display.

Transfective backing for indoor and outdoor viewability.

Power consumption: logic 1.98 W; backlight 5.4 W (LED) from backlight power board.

Touch screen

The 8-wire, 10.4 in, resistive touch-screen module provides a touch-based access to the graphical user interface. It functionally replaces a mouse for Windows navigation, substituting point and click with a touch. The touch screen has an anti-reflective coating that reduces glare when the instrument is used outdoors.

LCD controls

Backlighting is used for indoor viewing, and a combination of backlighting and ambient light is used for outdoor viewing. To control brightness, use the soft keys available on the Control Panel (**Start > Settings > Control Panel > Backlight**), or double tap the backlight icon (lower-right corner of display).

Backlighting is continuously adjustable, with the default level set to 66%. The backlight is extinguished during screen saver, suspend, and power down modes.

Processor system

The instrument processor architecture is similar to that of a handheld PC with the following exceptions:

- 640 x 480 TFT color display
- 8-wire touch screen
- SPI bus
- SMBus battery interface that supports two rechargeable battery packs
- Expanded power management system
- USB slave/host ports
- Dual PCMCIA ports standard
- PS/2 keyboard port
- Flash file system ROM for optional software and system backup
- Automatic Windows CE registry restoration during cold power on
- Instrument module power management system and additional power supplies
- Foreign language support
- Network support

Processor bus. The PXA255 processor external bus width is 32 bits and operates at 100 MHz.

Temperature sensor. The Processor board has an internal temperature sensor to monitor the temperature of the instrument.

Real-time clock. The Processor board real-time clock operates from a separate Lithium coin cell battery. The battery life expectancy is 7 years.

Built-in drivers. The Processor board is configured with vendor supplied Windows CE drivers for all ports. You can reinstall these drivers by reloading the operating system.

Flash ROM. The Processor board has the following flash ROM:

- 32 MB Flash ROM for the operating system and built-in drivers
- 32 MB Flash ROM for the nonvolatile file system memory (\BuiltInDisk)

SDRAM. The Processor board has 64 MB of DRAM. The Windows CE Control panel provides SDRAM allocation of program and data storage memory (**Start > Settings > Control Panel > System > Memory**).

NOTE. *When entering the Suspend state, registry information is automatically backed up to the flash ROM file system from SDRAM. During the suspend state, the SDRAM retains its contents. After approximately 2 hours, the analyzer powers down the SDRAM and enters the Shutdown (power down) state. User application data is lost when entering the shutdown state unless previously stored in nonvolatile memory.*

Firmware upgrade. You can upgrade instrument firmware over the RS-232 and USB ports, as well as by using a PCMCIA flash memory card.

Hardware and software configuration data. To check the hardware and software configurations of the instrument, do the following:

1. Select **Start > Programs > Tektronix Utilities > System Configuration**.
2. Open the **Software** or **Hardware** tab.
3. Select the item of interest from the list and then select **Properties**.

Electronic keying. The instrument supports electronic keying from the instrument modules to maintain the registry. The registry is updated at each power up. Registry information includes module name, module type, module description, and HW/SW/FW version numbers and location. If the instrument detects configuration incompatibilities, the user is notified.

Firmware backup. The instrument backs up the system registry to flash memory during the power down process.

External I/O ports and buses

All external ports are protected against electrostatic discharge and their power supplies against shorts.

Table 3: External ports and buses

| External port, signal, or bus | Description |
|-------------------------------|--|
| RS-232 port | EIA/TIA-574 compliant DTE interface with modem control lines. The Baud Rate is 115.2 kbps. |
| USB slave, host ports | Standard USB slave and host ports that support USB 1.1 standard. |
| Ethernet port | Standard RJ-45 connector that supports 10BaseT and 100BaseT Ethernet standards. |
| PCMCIA ports | Supports a single type III or dual type II PCMCIA cards. Any application software must be H500 & SA2500 instrument and Windows CE compatible. This port accepts both 3.3 V and 5 V PC cards. |
| Keyboard port | Supports PS/2 keyboards with Mini DIN connectors. Keyboards can be plugged in without shutting down the instrument. |
| DC supply jack | Accepts power from the AC power adapter for normal operation or to charge the internal batteries. Nominal supply voltage is 24 V _{DC} ±10%. |
| Headphone jack | A 3.5 mm jack. Inserting a headphone disables the internal speaker and microphone in the instrument. |
| Microphone jack | A 3.5 mm jack. 1.5 V bias supply, for 2 kΩ electret-type microphone. |

Internal I/O ports and buses

The internal ports are used to interface with the instrument module, display modules, and development ports.

Table 4: Internal ports and buses

| Internal port, signal, or bus | Description |
|-------------------------------|---|
| Color LCD Port | Interface: 3.3 V, 9-bit data (8 bits used), Red, Green, and Blue LCD Connector: 15 pin Backlight Connector: 4 pin |
| Touch screen port | Supports 8-wire, resistive, touch-screen panel with firmware calibration Touch-Screen connector: 8 pin |

Table 4: Internal ports and buses (cont.)

| Internal port, signal, or bus | Description |
|-------------------------------|---|
| SMBus port | Interfaces to two SMART Li-Ion battery packs. Compatible with Smart battery Interfaces from Inspired Energy and others. This bus is not available to the instrument module. (See page 28, <i>Power system</i> .) (See page 59, <i>Lithium-Ion battery maintenance</i> .) |
| Speaker port | -3 dB bandwidth: 100 Hz to 15 kHz Speaker: 28 mm diameter, 8 W, 1 W nominal, water resistant Connector: 2-pin header Connects to the internal speaker. Outputs instrument-generated audio. A volume control is available on the Control Panel (Start > Settings > Volume & Sounds). |
| Application interface port | Logic Levels: 3.3 V signals, 5 V tolerant Connector: 80-pin blind mate, Molex type SPI bus signal lines: SPIMISO (master-in-slave-out), SPIMOSI (master-out-slave-in), SPICLK<6... 1> (SPI clock), and SPISEL<6... 1> (instrument module select, active low). The Application Interface port is a full duplex Serial Peripheral Interface (SPI) bus interface between the platform and the instrument module. SPIMISO and SPIMOSI signals are tied together. SPISEL and SPICLK signals are unique for a module. The platform signals are always master; all other signals are slave. The platform addresses the module with a unique SPISEL signal. The instrument module picks up its SPISEL signal from the lowest numbered SPISEL pin of the interface connector on its front case. |
| Interrupt signals | The instrument modules use MODINTR<4... 1> signals for requesting service from the platform. These signals are open collector 3.3 V, active low, TTL-level. The instrument module generates the MODINTR1 signal on the Processor board. All module interrupt signals are OR-logic wired to form one interrupt to the CPU. The CPU can then decode which module asserted the interrupt. Pull-up resistors for these signals are located on the Processor board. |
| Audio input signal | Signals: AUDIP, AUDIN Level: 1 V _{RMS} , maximum Load: 10 kW Bandwidth: -3 dB, 100 Hz to 15 kHz A differential analog audio output signals from the instrument module input to the platform volume control. |

Table 4: Internal ports and buses (cont.)

| Internal port, signal, or bus | Description |
|-------------------------------|--|
| Audio output signal | <p>Signals: AUDOP, AUDON Level: 1 V_{RMS}, maximum Load: 40 kW per module, 10 kW minimum impedance Bandwidth: -3 dB, 100 Hz to 15 kHz</p> <p>A differential analog output signal from the platform built-in microphone to the input of an instrument module.</p> |
| Power bus | <p>Supplies power and controls the shut down of individual instrument modules to conserve battery power.</p> <p>MODON<4... 1>: 3.3 V CMOS-level signals. An active high turns on the corresponding instrument module. The module is MODON1. Only one CMOS load per line is allowed. A low level on this signal isolates all supplies from the instrument module. The signal must be active before addressing a module.</p> |
| System clock | 5 MHz, 3.3 V, TTL-level (SYSCLK) for use by the instrument module. |
| Timer signal | <p>3.3 V, TTL-level, implemented in hardware only. Programmable from 25 ms to 500 ms in 25 ms intervals. This signal can be used to synchronously accumulate measurement results to derive time correlated data.</p> |

Power system

The power system consists of an internal battery charger and power supplies for the internal boards and instrument module. The Processor board implements all power management operations. The battery board controls battery charging, battery selection, and the V_{main} value.

Power management. The platform processor system, peripheral devices, and I/O implement power management techniques similar to those used in hand-held HPCs. This includes powering down I/O ports, power supplies, and peripherals to a shutdown state while running the CPU in sleep mode; power to all circuits except the real-time clock and the power system micro-controller is turned off. The power management strategy also includes a screen-saver mode. In this state, power to the LCD logic and backlight are shut down while maintaining operation of the I/Os.

The platform uses a non-latching type power switch on the front-panel to implement power on/off and suspend/resume operations similar to an HPC. Unlike the HPC however, the platform manages power to the instrument module.

The platform shuts down power to the instrument module by pulling their respective MODON control signals low and then cutting the power. During power on from the suspend or shutdown state, the instrument module power supplies are turned on first and then the module is turned on using the MODON signals.

The power modes are:

- **Suspend mode.** The platform automatically enters shutdown mode to save battery power following a period of instrument inactivity, or when you press the front panel power button. You can set the length of this inactivity from the **Start > Settings > Control Panel > Power Management > Power Saver** tab. Before entering this mode, registry information and nonvolatile memory are backed up and all nonessential power supplies shut down. LCD backlights are turned off and the touch-screen display is inactivated. The instrument module will also be shut down.

During suspend mode, the real-time clock and SDRAM refresh remain active. To return from this state, you must press the front-panel power switch to power up the platform, which takes approximately one minute.

- **Display Power Saver mode.** The front-panel status indicator changes from Green to Amber to indicate the display Power Saver mode. In this state, the display and backlight are turned off to save power. Instrument modules remain powered on. Pressing the front-panel power switch cancels the Power Saver mode and returns the platform to an active state. Measurements that are running when you enter this mode continue to run.
- **Automatic Shutdown mode.** If a voltage is present on fine-pitched component pins under humid conditions, corrosion can occur over time. Placing the internal circuitry in shutdown mode when not in use can minimize this problem. If the platform remains in shutdown mode for more than two hours, the processor system, with the exception of the real-time clock, is completely powered off.

Transition to the power-down state occurs when the shutdown state timer times-out or the internal batteries becomes critically low. Pressing the front-panel power switch reactivates the internal circuitry and returns the platform to an active state.

Internal supplies to module. In addition to the power requirements of the internal circuit boards, the platform provides the following voltages to the instrument module.

Table 5: Platform voltage supplies to module

| Characteristic | Description |
|---|--|
| Voltages | +3.4 V DC ± 0.14 V, 5 A at 17 W ¹ -13 V DC ± 0.5 V, 1 A at 13 W +13 V DC ± 0.5 V, 1 A at 13 W |
| Instrument Power Supply | < 250 mV for ± 13 V |
| Noise (peak-to-peak) for 1 Megahertz bandwidth | < 100 mV for +3.4 V |

Table 5: Platform voltage supplies to module (cont.)

| Characteristic | Description |
|--------------------|---|
| Transient Response | For 50% to 75% step load, the initial transients are $\leq 10\%$ of the initial voltage set point. Recovery is $\leq 2\%$ of the set value within 0.5 ms. |
| Supply Monitoring | The built-in diagnostics verify the instrument module power supply status while running power diagnostics. If a problem is detected, the platform displays an out-of-tolerance warning message. |

¹ The 3.4 V supply may also be referred to as the 3.3 V supply in the rest of this document. 3.4 V is specified to account for the voltage drops across the connectors and Power FET switch used to control power to the instrument module.

Power sources. The platform and module can operate from the following supplies:

- **Batteries.** Powers the instrument using up to two Inspired Energy type NI2020HD24 10.8 V, 7200 mAh, Li-ion batteries.
- **External Supply (DC or AC):** Powers the instrument from a $24 V_{DC} \pm 10\%$ external source. If the external supply is connected while the platform is operating, the internal batteries will be disconnected without interrupting service. If the external supply is disconnected during service, the internal batteries are connected without disrupting service.

Fuse Protection is provided by an automatic resetting fuse device. This fuse is located in the external DC supply line on the Battery board. Requires no user intervention.

Internal charger. The sequential internal charger will charge a single 7200 mAh battery in approximately 4.5 hrs (two batteries requires approximately 9 hrs) if the platform is in shutdown mode. If the platform is operating, charging takes place at a reduced rate in order to maintain internal temperatures within limits and to avoid exceeding the capacity of the external supply. The charger is capable of determining the battery technology type and appropriate charging sequence, and is optimized for battery packs with nominal terminal voltages of between 7.2 and 12 volts. The maximum charging current is approximately 1.8 A in shutdown mode and 0.8 A in the power on mode.

If the Desktop Power Supply or In-Vehicle Power Adapter is connected, the internal batteries will charge if their capacity is low.

Charge status indicator. Low Battery Warning: Red indicates a low battery (less than 20% remaining capacity). Green indicates battery charging. The platform backs up current data and executes an orderly shutdown before complete loss of battery power.

Each Li-Ion battery pack has an internal microprocessor that monitors its charge level. To check the battery status, remove the battery from the analyzer. Then press the **PUSH** button on the side of the battery and note the charge value on the LED charge indicator.

Taskbar power status icon. A battery icon appears in the taskbar when the instrument operates from battery power. The icon displays the battery charge level in 10% increments. If two batteries are installed, the icon displays the average charge level of the two combined batteries. When the instrument operates from AC power (from the Desktop Power Supply) a plug icon appears in the Taskbar status area.

Battery system. The instrument uses up to two Inspired Energy type NI2020HD24 10.8 V, 7200 mAH, Li-ion batteries. You do not need special tools to replace the batteries. (See page 59, *Lithium-Ion battery maintenance*.)

Battery operation characteristics include:

- The battery power system operates the platform for approximately 9 hrs (12 watts load) from two Li-Ion batteries and approximately 4.5 hrs from a single battery. Run time for the platform plus application varies depending on the applications being run.
- Only one of two batteries will be in use at any given time when two batteries are installed.
- If two batteries are installed, you can remove and replace either battery without disrupting service.
- If a second battery is installed, the platform automatically switches operation to the second battery when the first battery reaches cut off capacity (5% reserve) or is removed. The transition is transparent and does not interrupt service.

Battery power management utility. The Batteries tab in the Power Management dialog box provides general information on battery status. This is the most accurate information to determine battery charge status and probable manufacture dates. (See page 61, *H500 and SA2500 Instrument-Specific battery maintenance*.)

Measurement module

The Measurement module contains no user-servicable parts. There are also no user adjustments on the Measurement module. The entire instrument must be returned for service. Service for the measurement module is not independently available.

Adjustment procedures

There are no manual or software adjustment procedures for the H500 or SA2500 Spectrum Analyzer instruments.

Cleaning

To clean the instrument, close or cover all instrument connectors, connector doors, and battery doors. Then use a soft cloth dampened with a solution of water and mild detergent to clean the instrument. Do not apply heavy pressure or scrub the display touch screen.



CAUTION. *To prevent damage to external surfaces, avoid using chemicals that contain benzene, toluene, xylene, acetone, or similar solvents. Do not use bleach or ammonia solutions for cleaning.*

To prevent damage to internal components, do not allow moisture to get into the instrument.

Removal and replacement procedures

This subsection contains procedures for the removal and replacement of all replaceable mechanical and electrical modules.

NOTE. *The instrument does not require calibration after removal and replacement of the indicated parts.*

Preparation



WARNING. *Before doing this or any other procedure in this manual, read the Safety Summary found at the beginning of this manual. Also, to prevent possible damage to the instrument components, read Preventing ESD in this section. (See page 38.)*

This subsection contains the following items:

- This preparatory information that you need to properly do the procedures that follow.
- List of tools required to remove and disassemble all modules.
- Procedures for removal and reinstallation of the electrical and mechanical modules.



CAUTION. *Disconnect the power adapter and remove all batteries from the instrument before disassembling the instrument.*

Equipment required

Table 6: Tools required

| Item no. | Name | Description | General Tool number |
|----------|--------------------|-------------------------------------|---------------------|
| 1. | Screwdriver handle | Accepts Torx-driver and Pozi bits | 620-440 |
| 2. | T-9 Torx tip | Used for removing instrument screws | 640-234 |
| 3. | T-10 Torx tip | Used for removing instrument screws | 640-235 |
| 4. | T-15 Torx tip | Used for removing instrument screws | 640-247 |
| 5. | P0 Pozi tip | Used for removing instrument screws | 640-234 |

Table 6: Tools required (cont.)

| Item no. | Name | Description | General Tool number |
|----------|---------------------|---|---------------------|
| 6. | 1/4 inch nut driver | Used to remove standoffs | Standard tool |
| 7. | Torque driver | Accepts Torx tips, Pozi tips, and open-end wrenches | Standard tool |

Preventing electrostatic damage

Electrostatic discharge (ESD) can damage components in the instrument. To prevent, ESD:

- Do not touch exposed components or connector pins unless you are using ESD protective measures, such as wearing a properly grounded antistatic wrist strap.
- Handle boards and modules little as possible.
- Do not slide boards or modules across work surfaces.
- Transport and store boards and modules in a static-protected bag or container.

Removal procedures

NOTE. *Unless directed otherwise, installation is the reverse of the removal procedure. Note cable routing when disassembling so that you can route the cables correctly during assembly.*

NOTE. *The instrument does not require calibration after removal and replacement of the indicated parts.*

Remove module from platform

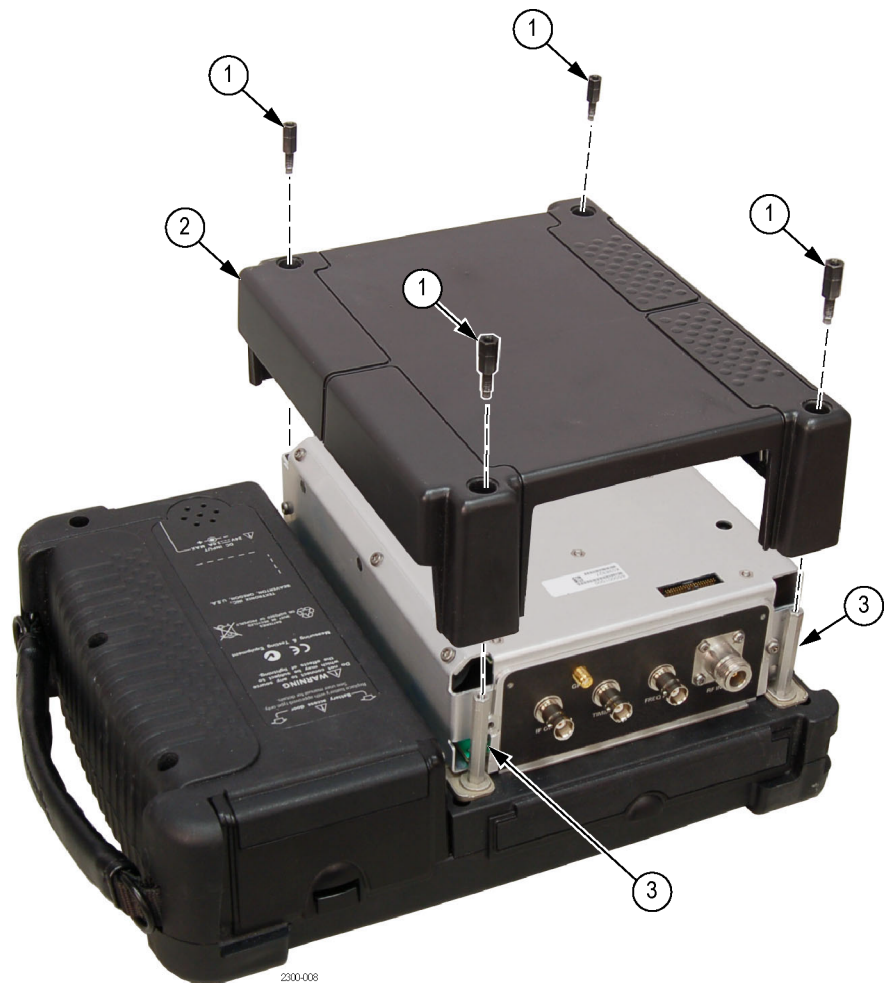

1. Remove the four 1/4" standoff posts.
When reinstalling these standoffs, torque them to 8 in/lb.
2. Remove the cosmetic cover.
3. Remove the four 1/4" standoff posts that secure the module to the mainframe chassis.
When reinstalling these standoffs, torque them to 12 in/lb.
4. Remove the module from the platform.



CAUTION. Do not open the module. There are no user-serviceable parts. If the module is opened, you must return the entire instrument to Tektronix for calibration.

Remove platform rear cover

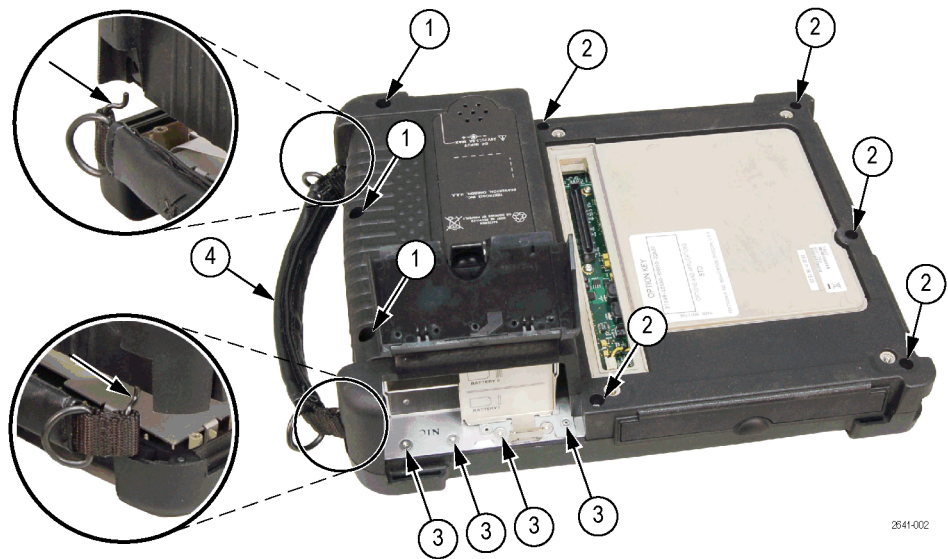

2641-002

1. Remove the three screws from the side of the rear case above the battery area.
When reinstalling these screws, torque them to 8 in/lb.
2. Remove the five screws from the bottom, side, and top edge of the rear case.
When reinstalling these screws, torque them to 8 in/lb.
3. Remove the four screws from the battery compartment area.
When reinstalling these screws, torque them to 8 in/lb.
4. Lift case one to two inches and remove the carrying strap and strap pins. Also remove the strap pins from the other corners of the case.

Separate front and rear cases

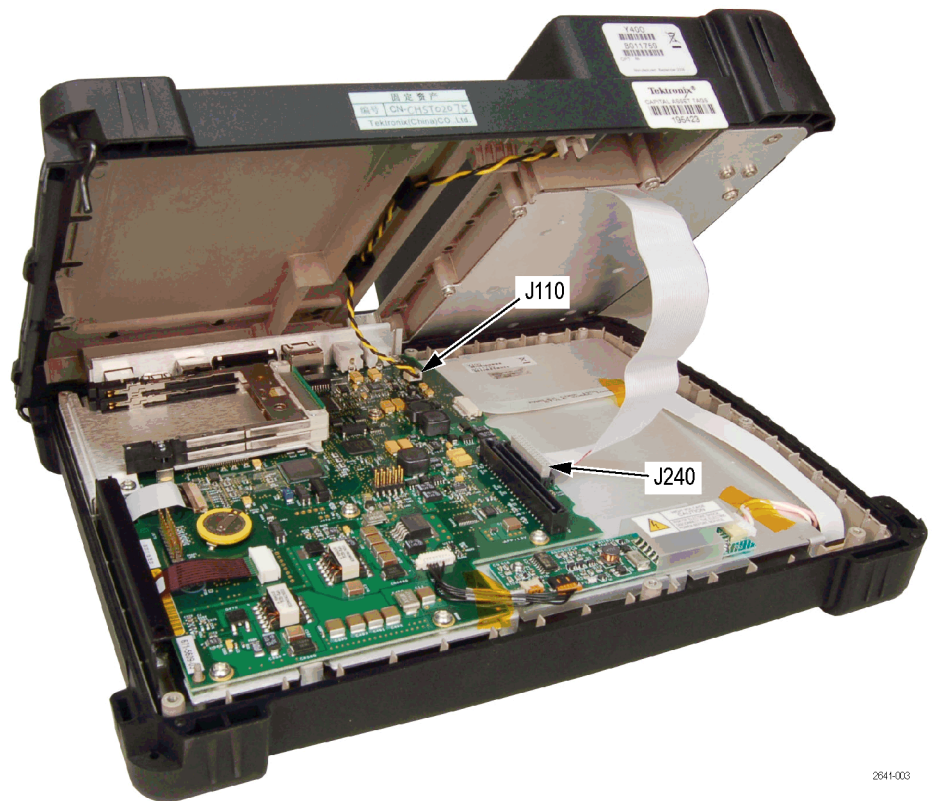

2641-003

Separate the front and back instrument cases enough to access connecting cables. Disconnect **J110** and **J240**.

Rear case: remove battery compartment

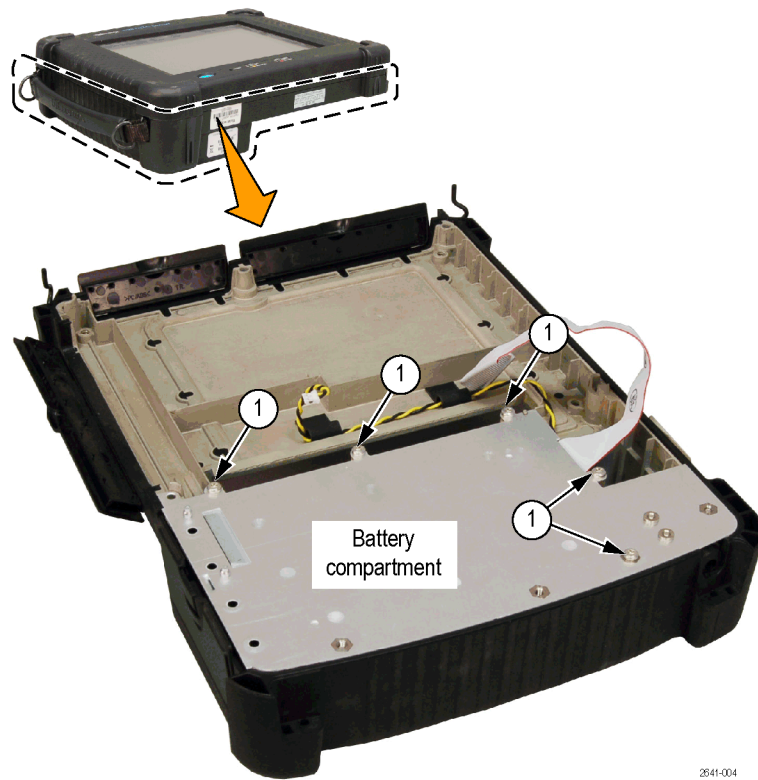

2541-004

1. Remove the five screws from the battery compartment. Lift and pivot the battery compartment towards the bottom of the instrument to access connecting cables

When reinstalling these screws, torque them to 8 in/lb.

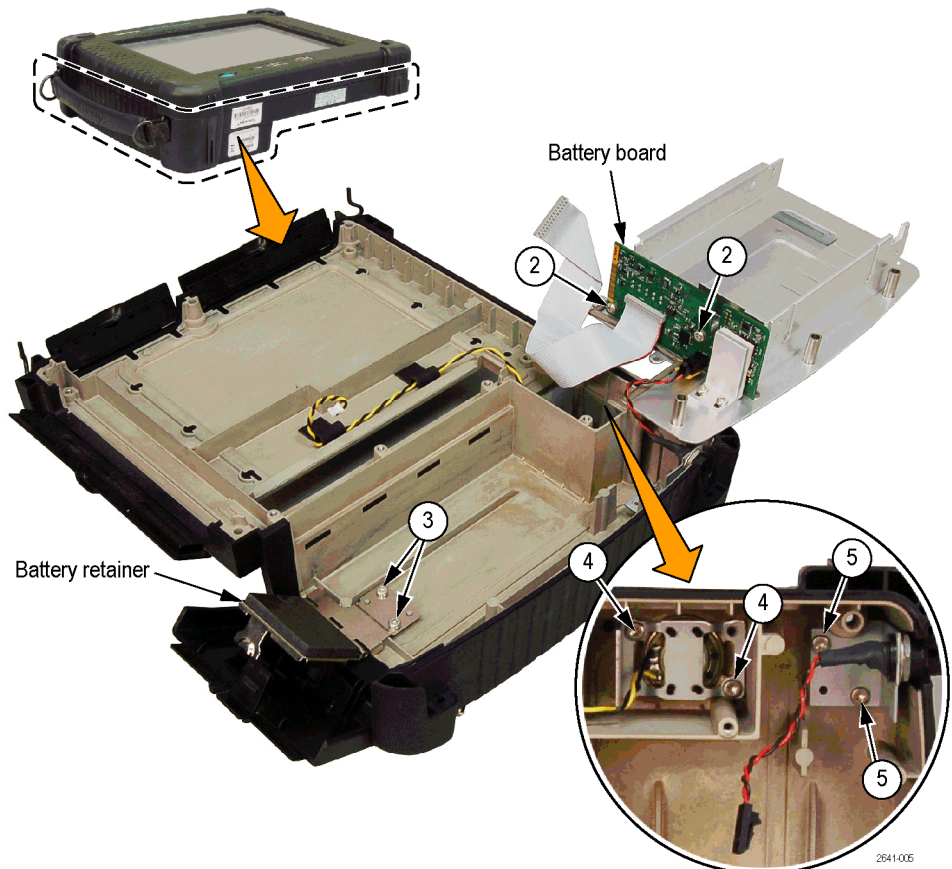

2. Remove the two screws and remove the battery connector board from the battery panel chassis. Disconnect the cable that comes from the DC power jack.

When reinstalling these screws, torque them to 8 in/lb.



CAUTION. Do not remove the angle bracket with the foam thermal pad from the battery panel chassis, as it is set to a specific position.

3. Remove the two screws and remove the battery retainer hinge assembly.
When reinstalling these screws, torque them to 8 in/lb.
4. Remove the two screws and remove the speaker bracket.

When reinstalling these screws, torque them to 8 in/lb.

5. Remove the two screws and remove the DC power jack and bracket.

When reinstalling these screws, torque them to 8 in/lb.

Front case: remove CPU board assembly

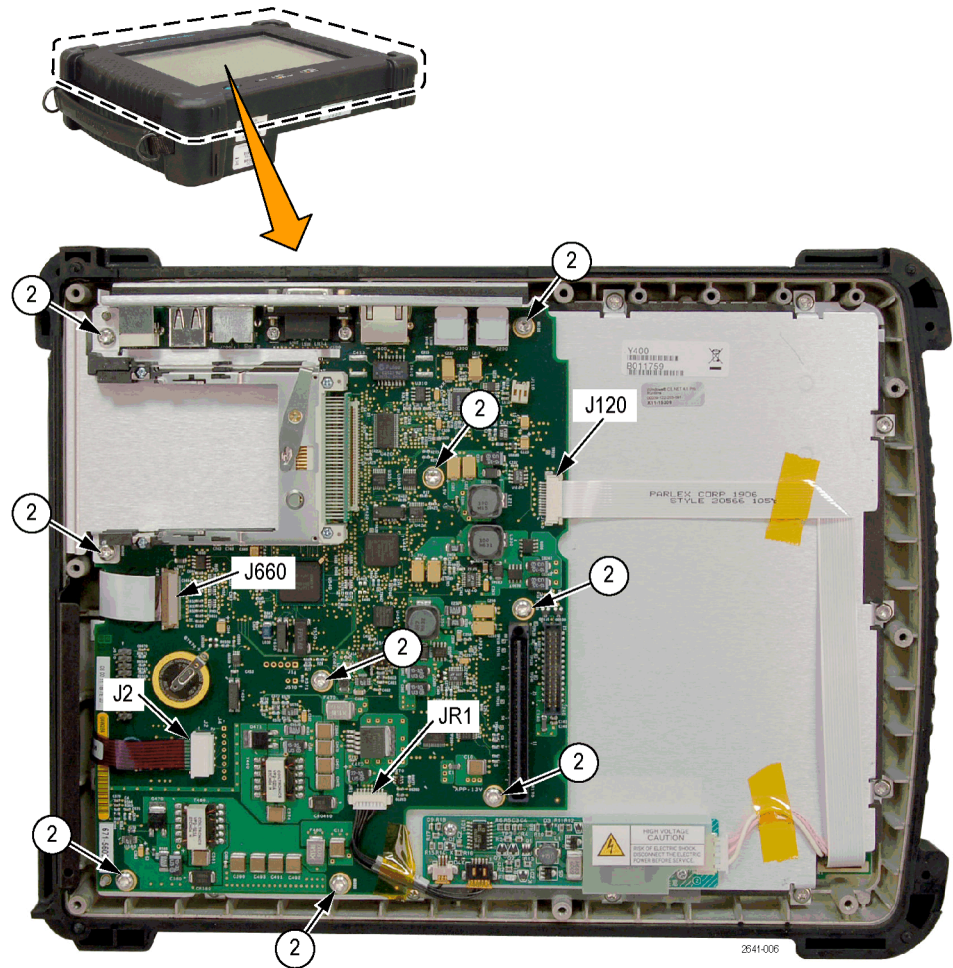

1. Disconnect **JR1**, **J2**, **J120**, and **J660**. Disconnect the cables from the left end of the backlight board.

2. Remove the nine screws and remove the CPU board assembly.

When reinstalling these screws, torque them to 8 in/lb.

Front case: remove display components and power switch

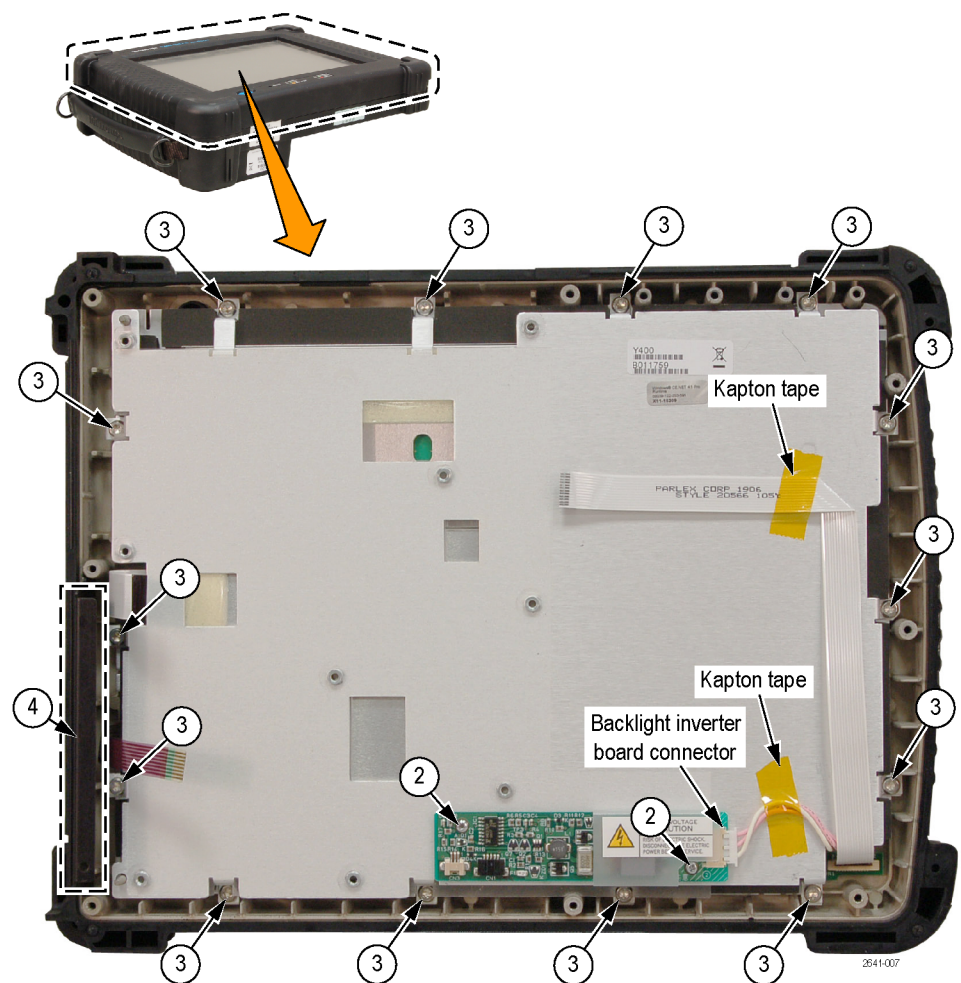

1. Disconnect the cable from the right end of the backlight board. Untape the cable from the plate.
2. Remove the 2 screws from the backlight board and remove the board.
When reinstalling these screws, torque them to 2.5 in/lb.
3. Remove the 14 screws from the display assembly.
When reinstalling these screws, torque them to 8 in/lb.
4. Remove the drive bay cover bracket from the front case. This is a pressure-fit bracket.

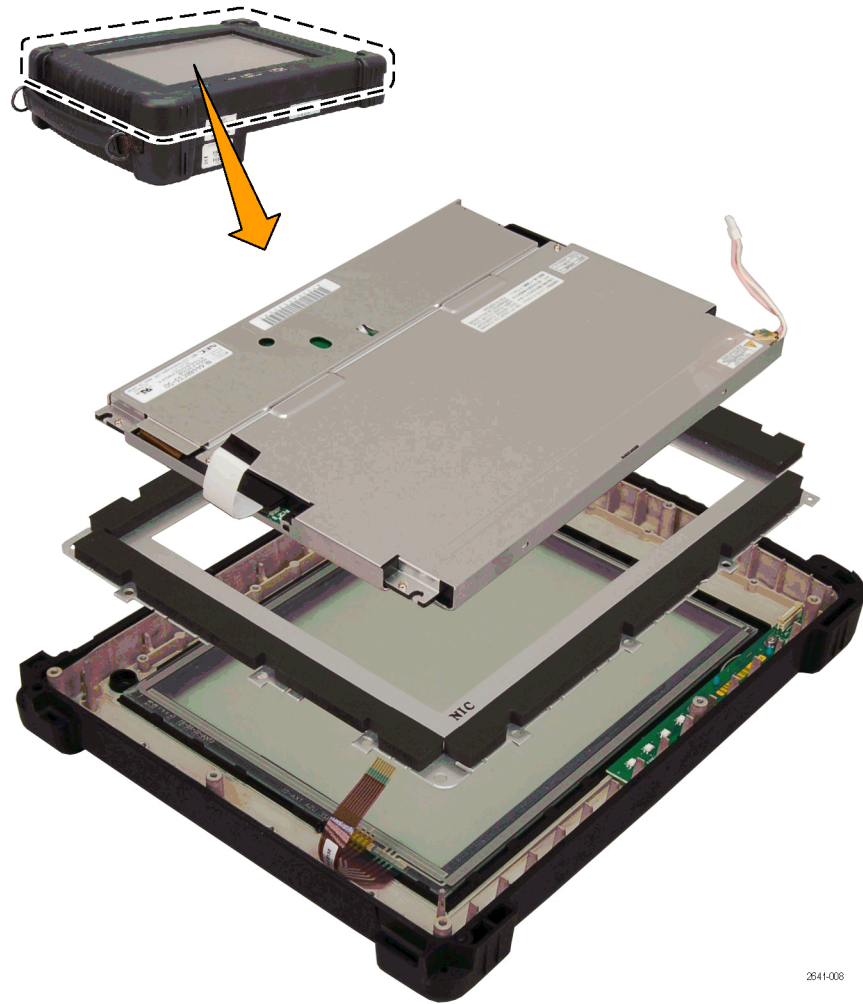

2541-008

5. Lift the display assembly components from the front case.

Front case: remove the touch panel and power switch board

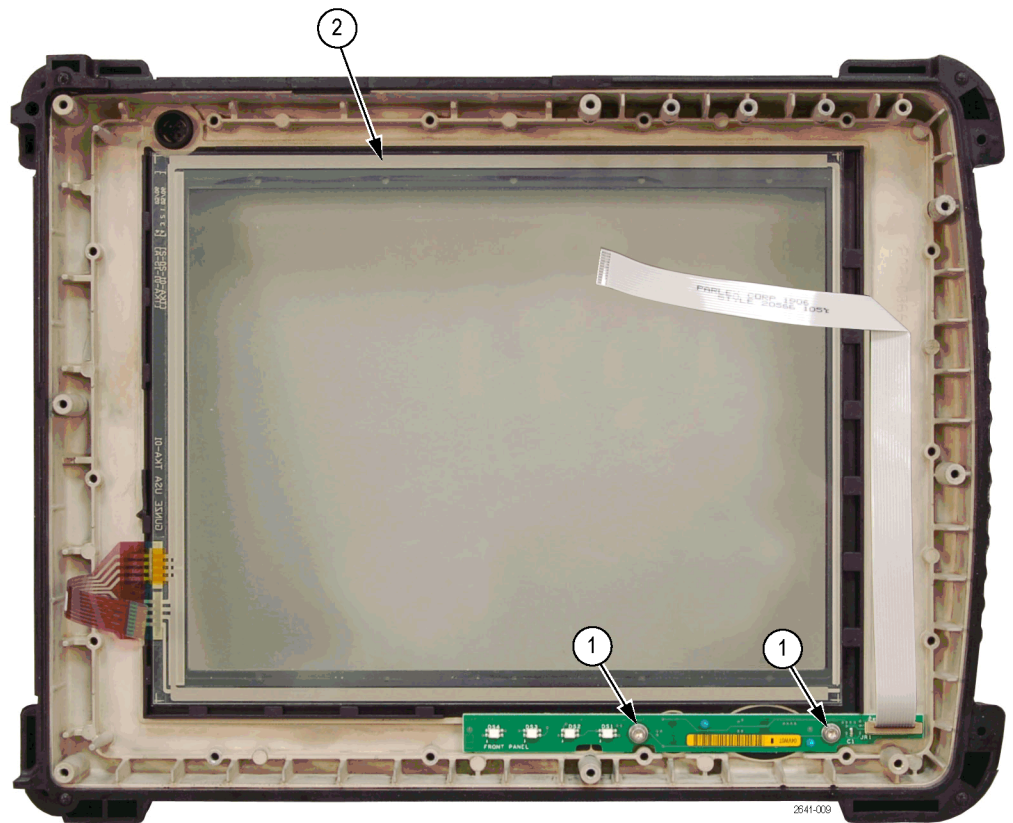

1. Remove the two screws and remove the front panel board assembly.
When reinstalling these screws, torque them to 4 in/lb.
2. Remove the touch panel assembly.

Troubleshooting



WARNING. Before doing this or any other procedure in this manual, read the Safety Summary found at the beginning of this manual. Also, to prevent possible injury to service personnel or damage to the instrument components, read Installation in the product user manual, available on the Web at www.tektronix.com, and Preventing ESD in this document. (See page 38.)

This section contains information and procedures designed to help you isolate faulty modules in the H500 or SA2500 Spectrum Analyzer.

This section assumes that service personnel have the prerequisite skills required to work on this instrument. Details of instrument operation are not in this manual.

The following diagram shows the processor and backlight inverter board connections. Use this diagram while doing the troubleshooting steps in this section.

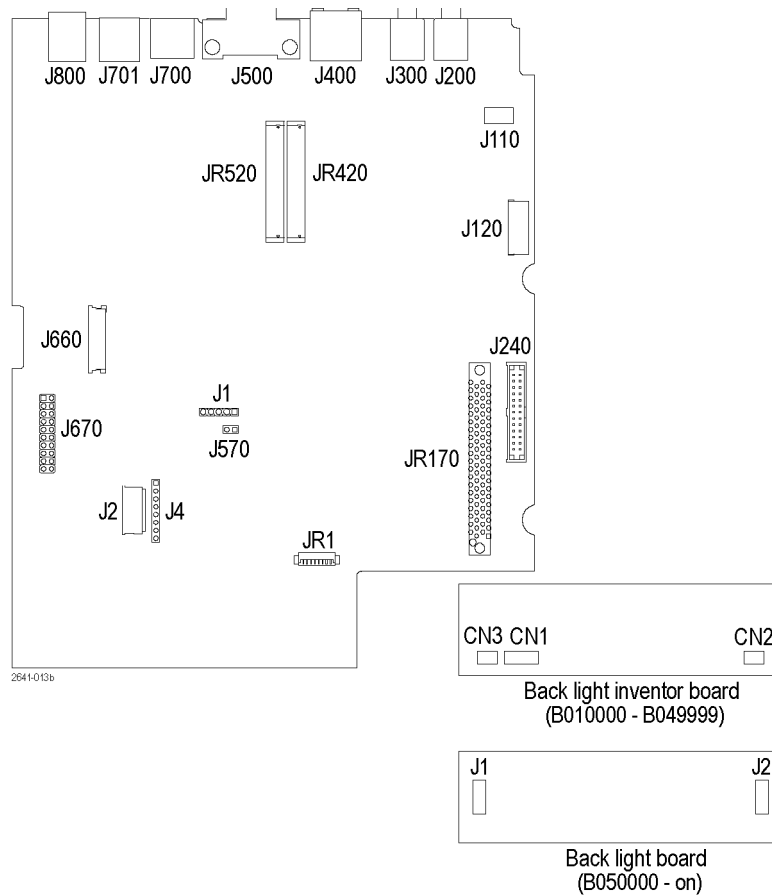

Figure 1: Processor and backlight board input and output connections

Power on self test

Press the large oval button in the lower-left corner to power on the platform. The power status indicator illuminates immediately. Allow several seconds for the self test to complete.

NOTE. *The Batteries indicator briefly illuminates red if the batteries are too low to power on the analyzer. Connect the external power supply or charge the batteries.*

If the platform does not begin to boot at power up (no power up sound), try removing the CMOS battery backup from the Processor board (BT520). Wait approximately 15 seconds and reinsert the battery into its socket; then press the power switch again. If the platform still does not boot, replace the Processor board.

Display does not operate

If the display does not operate try the following procedures.

Display cable disconnected

Do the following:

1. Verify that both ends of the LCD display cable are properly oriented and fully seated in their connectors.
2. Disconnect and reconnect the backlight cable connectors.

If these steps do not resolve the problem, replace the display.

Backlight does not illuminate (Serial number B010000 to B049999)

Verify the following backlight-related voltages.



WARNING. *To avoid electrical shock or burn, do not touch the backlight connectors on the backlight inverter board.*

Table 7: Backlight-related voltages

| Board location | Pin | Location | Measured voltage | Frequency |
|--------------------------|------|----------|-----------------------------|-----------|
| Backlight Inverter board | 2, 3 | CN2 | 510 V _{RMS} | 54 kHz |
| CPU board | 1, 2 | JR 1 | +12 V _{DC} | |
| | 6 | JR 1 | 0 V to +2.4 V _{DC} | |
| | 3, 4 | J660 | 3.3 V _{DC} | |

Backlight does not illuminate (serial number B050000 onward)

Table 8: Backlight-related voltages

| Board location | Pin | Location | Measured voltage |
|-----------------|------------|----------|-----------------------------|
| Backlight board | 1, 3, 5, 7 | J2 | 27.0 V _{DC} |
| CPU board | 1, 2 | JR 1 | +12 V _{DC} |
| | 6 | JR 1 | 0 V to +2.4 V _{DC} |
| | 3, 4 | J660 | 3.3 V _{DC} |

Display image inverted (Rotated 180°)

Disconnect and then reconnect the LCD cable connectors. To open connector J660, insert your thumbnail beneath the dark brown part (hinge) and the cable. Carefully lift up the hinged brown part to release the cable. Reseat the cable and close the hinge. J660 pin 1 must supply +3.3 V_{DC} for correct display orientation.

Touch screen does not operate

Try the following:

- Disconnect and then reconnect the touch screen cable connectors.
- J4 pins 1-8: verify that pins 1, 2, 3, and 4 of connector J1 are at +3 V_{DC} when the touch panel is not pressed. Verify that pins 1 through 8 toggle their value when the touch panel is pressed.

If these do not resolve the problem, replace the touch screen panel.

Signal and connector information

The following tables list pin, signal name, and signal information for the main platform connectors.

Table 9: PCMCIA interface connectors JR420, JR520

| Pin | Signal name | Signal information | Pin | Signal name | Signal information |
|-----|-------------|--------------------|-----|-------------|--------------------|
| 1 | GND | | 35 | GND | |
| 2 | D3 | | 36 | -CD1 | |
| 3 | D4 | | 37 | D11 | |
| 4 | D5 | | 38 | D12 | |
| 5 | D6 | | 39 | D13 | |
| 6 | D7 | | 40 | D14 | |
| 7 | -CEL | | 41 | D15 | |
| 8 | A10 | | 42 | -CEH | |

Table 9: PCMCIA interface connectors JR420, JR520 (cont.)

| Pin | Signal name | Signal information | Pin | Signal name | Signal information |
|-----|-------------|---------------------|-----|--------------|---------------------|
| 9 | -OE | | 43 | REF/-VSI | |
| 10 | A11 | | 44 | -IORD | |
| 11 | A9 | | 45 | -IOWR | |
| 12 | A8 | | 46 | A17 | |
| 13 | A13 | | 47 | A18 | |
| 14 | A14 | | 48 | A19 | |
| 15 | -WE | | 49 | A20 | |
| 16 | -IREQ/READY | | 50 | A21 | |
| 17 | VCC | 0.4 V _{DC} | 51 | VCC | 0.4 V _{DC} |
| 18 | VPP | 0.4 V _{DC} | 52 | VPP | 0.4 V _{DC} |
| 19 | A16 | | 53 | A22 | |
| 20 | A15 | | 54 | A23 | |
| 21 | A12 | | 55 | A24 | |
| 22 | A7 | | 56 | A25 | |
| 23 | A6 | | 57 | RSVD/-VS2 | |
| 24 | A5 | | 58 | -RESET | |
| 25 | A4 | | 59 | -WAIT | |
| 26 | A3 | | 60 | -INPACK | |
| 27 | A2 | | 61 | -REG | |
| 28 | A1 | | 62 | SPKR/BVD2 | |
| 29 | A0 | | 63 | -STSCHG/BVD1 | |
| 30 | D0 | | 64 | D8 | |
| 31 | D1 | | 65 | D9 | |
| 32 | D2 | | 66 | D10 | |
| 33 | -IOIS16/WP | | 67 | -CD2 | |
| 34 | GND | | 68 | GND | |

Table 10: Application module connector JR170

| Pin | Signal name | Signal information | Pin | Signal name | Signal information |
|-----|-------------|--------------------|-----|-------------|--------------------|
| 1 | -13 V | | 41 | -13 V | |
| 2 | -13 V | | 42 | GND | |
| 3 | +3.4 V | | 43 | RSVD | |
| 4 | +3.4 V | | 44 | RSVD | |
| 5 | NC1 | | 45 | GND | |
| 6 | GND | | 46 | +3.4 V | |

Table 10: Application module connector JR170 (cont.)

| Pin | Signal name | Signal information | Pin | Signal name | Signal information |
|-----|-------------|--|-----|-------------|--------------------|
| 7 | SYSCLK | +5 V high | 47 | +3.4 V | |
| 8 | GND | | 48 | GND | |
| 9 | RSVD | | 49 | +13 V | |
| 10 | RSVD | | 50 | +13 V | |
| 11 | GND | | 51 | GND | |
| 12 | AUDIOOUT- | | 52 | +13. V | |
| 13 | AUDIOOUT+ | | 53 | +13. V | |
| 14 | GND | | 54 | GND | |
| 15 | MODON6 | GND | 55 | AUDIOIN- | |
| 16 | MODON5 | GND | 56 | AUDIOIN+ | |
| 17 | MODON4 | | 57 | GND | |
| 18 | MODON3 | | 58 | -MODIRQ6 | +5 V high |
| 19 | MODON2 | | 59 | -MODIRQ5 | +5 V high |
| 20 | MODON1 | | 60 | -MODIRQ4 | +5 V high |
| 21 | -RESET | | 61 | -MODIRQ3 | +5 V high |
| 22 | SPISEL6 | +5 V High | 62 | -MODIRQ2 | +5 V high |
| 23 | SPISEL5 | +5 V High | 63 | -MODIRQ1 | +5 V high |
| 24 | SPISEL4 | +5 V High | 64 | GND | |
| 25 | SPISEL3 | +5 V High | 65 | SPICLK6 | GND |
| 26 | SPISEL2 | +5 V High | 66 | GND | |
| 27 | SPISEL1 | +5 V High | 67 | SPICLK5 | GND |
| 28 | NC2 | | 68 | GND | |
| 29 | TIMER | 500 mV, 2.5 μ s/ 300 ns pulse | 69 | SPICLK4 | +5 V high |
| 30 | +3.4 V | | 70 | GND | |
| 31 | +3.4 V | | 71 | SPICLK3 | +5 V high |
| 32 | STST | | 72 | GND | |
| 33 | +3.4 V | | 73 | SPICLK2 | +5 V high |
| 34 | +3.4 V | | 74 | GND | |
| 35 | TXTRIG | | 75 | SPICLK1 | +5 V high |
| 36 | +3.4 V | | 76 | GND | |
| 37 | +3.4 V | | 77 | SPIRXD | +5 V high |
| 38 | RXTRIG | | 78 | GND | |
| 39 | GND | | 79 | SPITXD | +5 V high |
| 40 | EXTRIG | | 80 | GND | |

Table 11: Internal speaker connector J110

| Pin | Signal name | Signal information |
|-----|-------------|-----------------------------|
| 1 | VO1 | 2.4 V _{DC} nominal |
| 2 | VO2 | 2.4 V _{DC} |

Table 12: External microphone connector J200

| Pin | Signal name | Signal information |
|-----|-------------|--------------------|
| 1 | GND | |
| 2 | TIP | |
| 3 | MICPWR | |
| 4 | NC | |
| 5 | NC | |
| 6 | NC | |
| 7 | NC | |

Table 13: Power connector J240

| Pin | Signal name | Signal information |
|-----|-------------|------------------------|
| 1 | GND | |
| 2 | DC IN | 7 - 24 V _{DC} |
| 3 | DC IN | 7 - 24 V _{DC} |
| 4 | DC IN | 7 - 24 V _{DC} |
| 5 | DC IN | 7 - 24 V _{DC} |
| 6 | DC IN | 7 - 24 V _{DC} |
| 7 | GND | |
| 8 | GND | |
| 9 | GND | |
| 10 | VCC_EN | Enables V regulators |
| 11 | GND | |
| 12 | RESUME* | Power button |
| 13 | BB_PWR_SW | Digital |
| 14 | GND | |
| 15 | LED4_RED | Charge LED |
| 16 | LED4_GRN | Charge LED |
| 17 | GND | |
| 18 | HOST_PWR | Digital |
| 19 | PIC_INT* | Digital |
| 20 | GND | |
| 21 | SYS_PWR_DET | 3.3 V _{DC} |
| 22 | GND | |

Table 13: Power connector J240 (cont.)

| Pin | Signal name | Signal information |
|-----|-------------|--------------------|
| 23 | GNDBB_SCL | Serial clock |
| 24 | GND | |
| 25 | BB_SDA | Serial data |
| 26 | GND | |

Table 14: Front-panel switch/LED connector J120

| Pin | Signal name | Signal information |
|-----|-------------|---------------------------------------|
| 1 | +3.3 V | 3.3 V _{DC} |
| 2 | -LED1_RED | 3.3 to 1.3 V _{DC} (on/off) |
| 3 | -LED1_GRN | 3.3 to 1.3 V _{DC} (on/off) |
| 4 | -LED2_RED | 3.3 to 1.3 V _{DC} (on/off) |
| 5 | -LED2_GRN | 3.3 to 1.3 V _{DC} (on/off) |
| 6 | -LED3_RED | 3.3 to +.3 V _{DC} (on/off) |
| 7 | -LED3_GRN | 3.3 to 1.3 V _{DC} (on/off) |
| 8 | -LED4_RED | 3.3 to 1.3 V _{DC} (on/off) |
| 9 | -LED4_GRN | 3.3 to 1.3 V _{DC} (on/off) |
| 10 | -RESUME | 5 V _{DC} (normal position) |
| 11 | -RESET | 3.3 V _{DC} (normal position) |
| 12 | GND | |

Table 15: Serial port connector J500

| Pin | Signal name | Signal information |
|-----|-------------|--------------------|
| 1 | DCD | |
| 2 | -RXD | |
| 3 | -TXD | |
| 4 | DTR | |
| 5 | GND | |
| 6 | DSR | |
| 7 | RTS | |
| 8 | CTS | |
| 9 | RI | |

Table 16: JTAG port connector J670

| Pin | Signal name | Pin | Signal name |
|-----|-------------|-----|-------------|
| 1 | +3.3 V | 11 | GND |
| 2 | +3.3 V | 12 | GND |

Table 16: JTAG port connector J670 (cont.)

| Pin | Signal name | Pin | Signal name |
|-----|-------------|-----|-------------|
| 3 | ICE_TRST* | 13 | PX_TDO |
| 4 | GND | 14 | GND |
| 5 | PX_TDI | 15 | ICE_SRST* |
| 6 | GND | 16 | GND |
| 7 | PX_TMS | 17 | N.C. |
| 8 | GND | 18 | GND |
| 9 | PX_TCK | 19 | N.C. |
| 10 | GND | 20 | GND |

Table 17: PS/2 keyboard connector J700

| Pin | Signal name | Signal information |
|-----|-------------|--------------------|
| 1 | DATA | |
| 2 | NC | |
| 3 | GND | |
| 4 | +5 V | |
| 5 | CLK | |
| 6 | NC | |

Table 18: Headphone connector J300

| Pin | Signal name |
|-----|-------------|
| 1 | GND |
| 2 | SPKR |
| 3 | SPRR |
| 4 | HS |
| 5 | -HS |
| 6 | NC |
| 7 | NC |

Table 19: TFT color display connector J660

| Pin | Signal name | Signal information |
|-----|-------------|----------------------------------|
| 1 | GND | |
| 2 | DOT CLK | +3 V, 4.8 MHz |
| 3 | HSYNC | 1 ms pulse, +3 V over 38 μ s |
| 4 | VSYNC | 1 ms pulse every 8 ms |
| 5 | GND | |
| 6 | GND | |

Table 19: TFT color display connector J660 (cont.)

| Pin | Signal name | Signal information |
|-----|-------------|------------------------|
| 7 | GND | |
| 8 | GND | |
| 9 | RED-3 | +3 V data, mostly high |
| 10 | RED-4 | +3 V data, mostly high |
| 11 | RED-5 | +3 V data, mostly high |
| 12 | GND | |
| 13 | GND | |
| 14 | GND | |
| 15 | GND | |
| 16 | GRN-3 | +3 V data |
| 17 | GRN-4 | +3 V data |
| 18 | GRN-5 | +3 V data |
| 19 | GND | |
| 20 | GND | |
| 21 | GND | |
| 22 | GND | |
| 23 | BLU-3 | +3 V data |
| 24 | BLU-4 | +3 V data |
| 25 | BLU-5 | +3 V data |
| 26 | GND | |
| 27 | DEPV | |
| 28 | LCD_3V | |
| 29 | LCD_3V | |
| 30 | NC | |
| 31 | RVRSE | +3.3 V |

Table 20: TFT backlight inverter board, connector CN2 (Applies to instrument serial numbers B010000-B049999)

| Pin | Signal name | Signal information |
|-----|-------------|-------------------------------|
| 1 | GND | |
| 2 | AC-HV1 | 510 V _{RMS} , 54 kHz |
| 3 | AC-HV2 | 510 V _{RMS} , 54 kHz |

Table 21: TFT backlight power board, connector J2 (Applies to instrument serial numbers B050000 and higher)

| Pin | Signal name | Signal information |
|-----|------------------|--------------------|
| 1 | V _{out} | 27 V |
| 2 | Row1 | 0.6 V – 1 V |
| 3 | V _{out} | 27 V |
| 4 | Row2 | 0.6 V – 1 V |
| 5 | V _{out} | 27 V |
| 6 | Row3 | 0.6 V – 1 V |
| 7 | V _{out} | 27 V |
| 8 | Row4 | 0.6 V – 1 V |

Table 22: Touch screen connector J4 and J2

| J4 Pin | J2 Pin | Signal name | Signal information |
|--------|--------|-------------|--------------------|
| 1 | 5 | XEXCITEL | Excite left |
| 2 | 8 | XSENSEL | Sense left |
| 3 | 7 | XSENSER | Sense right |
| 4 | 6 | XEXCITER | Excite right |
| 5 | 4 | YEXCITEB | Excite bottom |
| 6 | 3 | YSENSEB | Sense bottom |
| 7 | 2 | YSENSET | Sense top |
| 8 | 1 | YEXCITET | Excite top |

Table 23: Ethernet connector J400

| Pin | Signal name | Signal information |
|-----|-------------|----------------------|
| 1 | TX+ | Transmit + |
| 2 | TX- | Transmit - |
| 3 | RX+ | Receive |
| 4 | NC | |
| 5 | NC | |
| 6 | RX- | Receive |
| 7 | NC | |
| 8 | NC | |
| 9 | GND | Ground |
| 10 | GND | Ground |
| 11 | NC | |
| 12 | NC | |
| 13 | LINKLED* | LED cathode |
| 14 | 3.3V | LED anode (resistor) |

Table 23: Ethernet connector J400 (cont.)

| Pin | Signal name | Signal information |
|-----|-------------|----------------------|
| 15 | LANLED* | LED cathode |
| 16 | 3.3V | LED anode (resistor) |

Table 24: USB 1.1 series A host connector J701

| Pin | Signal name | Signal information |
|-----|---------------|--------------------|
| 1 | USB_CONNECTED | VBUS |
| 2 | USB_HDN | DATA- |
| 3 | USB_HDP | DATA+ |
| 4 | GNDS | Signal ground |
| 5 | CGND | Case ground |
| 6 | CGND | Case ground |

Table 25: USB 1.1 series B slave connector J800

| Pin | Signal name | Signal information |
|-----|-------------|--------------------|
| 1 | USB_HPWR | VBUS |
| 2 | USB_N | DATA- |
| 3 | USB_P | DATA+ |
| 4 | GNDS | Signal ground |
| 5 | CGND | Case ground |
| 6 | CGND | Case ground |

Table 26: Backlight connector JR1/J1

| Pin | Signal name | Signal information |
|-----|-------------|---|
| 1 | +12BL | +12 V supply |
| 2 | +12BL | +12 V supply |
| 3 | GND | Ground |
| 4 | GND | Ground |
| 5 | +5V | Not used |
| 6 | BL_CTRL | Intensity control |
| 7 | GND | Instruments with serial number B010000-B049999: Not used Instruments with serial number B050000 onward: Ground |
| 8 | NC | Not used |

Lithium-Ion battery maintenance

Lithium-Ion rechargeable batteries require routine maintenance and care in their use and handling. Read and follow the information in this document to safely use Lithium-Ion batteries and achieve the maximum battery life span.

Key information

Use only Tektronix-approved batteries in your Tektronix products.

Do not leave batteries unused for extended periods of time, either in the product or in storage. When a battery has not been used for six months, check the charge status and charge or dispose of the battery as appropriate.

The typical estimated life of a Lithium-Ion battery is about two to three years or 300 to 500 charge cycles, whichever occurs first. One charge cycle is a period of use from fully charged, to fully discharged, and fully recharged again. Use a two to three year life expectancy for batteries that do not run through complete charge cycles.

Rechargeable Lithium-Ion batteries have a limited life and will gradually lose their capacity to hold a charge. This loss of capacity (aging) is irreversible. As the battery loses capacity, the length of time it will power the product (run time) decreases.

Lithium-Ion batteries continue to slowly discharge (self-discharge) when not in use or while in storage. Routinely check the battery's charge status. The product user manual typically includes information on how to check battery status and battery charging instructions. The latest product manuals are available at www.tektronix.com/manuals.

Battery maintenance

- Observe and note the run time that a new fully-charged battery provides for powering your product. Use this new battery run time as a basis to compare run times for older batteries. The run time of your battery will vary depending on the product's configuration and the applications that you run.
- Routinely check the battery's charge status.
- Carefully monitor batteries that are approaching the end of their estimated life.
- Consider replacing the battery with a new one if you note either of the following conditions:
 - The battery run time drops below about 80% of the original run time.
 - The battery charge time increases significantly.

Charging Always follow the charging instructions provided with your product. Refer to your product's user manual and/or online help for detailed information about charging its battery. The latest version of your Tektronix product user manual is available at www.tektronix.com.

NOTE. *When you troubleshoot battery issues for dual battery configurations, test one battery and one battery slot at a time. A defective battery can prevent the battery in the opposite slot from charging, leaving you with two uncharged batteries.*

- Storage**
- Charge or discharge the battery to approximately 50% of capacity before storage.
 - Remove the battery and store it separately from the product.
 - Store the battery at temperatures between 5 °C and 20 °C (41 °F and 68 °F).
 - Charge the battery to approximately 50% of capacity at least once every six months.

NOTE. *The battery self-discharges during storage. Higher temperatures (above 20 °C or 68 °F) reduce the battery storage life.*



CAUTION. *If a battery is stored or otherwise unused for an extended period without following these instructions, and the battery has no charge remaining when you check it, consider it to be damaged. Do not attempt to recharge it or to use it. Replace it with a new battery.*

- Handling precautions**
- Do not disassemble, open, crush, bend, deform, puncture, or shred a battery.
 - Do not drop a battery or expose the battery to excessive shock or vibration.
 - Do not short circuit a battery or allow metallic or conductive objects to contact the battery terminals.
 - Do not dispose of a battery in fire or water.
 - Do not use the battery to power any devices other than the instrument for which it was designed.
 - Keep the battery away from personnel that are not trained to use the instrument.
 - Do not expose a battery to temperatures above 60 °C (140 °F).

- Keep the battery away from children.
- Do not use a damaged battery.
- If a battery pack is leaking fluids, do not touch any fluids. Properly dispose of a leaking battery pack (see *Disposal and Recycling* in this document).



WARNING. *In case of eye contact with battery fluids, do not rub eyes. Immediately flush eyes thoroughly with water for at least 15 minutes, lifting upper and lower lids, until no evidence of the fluid remains. Seek medical attention.*

Transportation

- Always check all applicable local, national, and international regulations before transporting a Lithium-Ion battery.
- Transporting an end-of-life, damaged, or recalled battery may, in certain cases, be specifically limited or prohibited.

Disposal and recycling

- Lithium-Ion batteries are subject to disposal and recycling regulations that vary by country and region. Always check and follow your applicable regulations before disposing of any battery. Contact Rechargeable Battery Recycling Corporation (www.rbrc.org) for U.S.A. and Canada, or your local battery recycling organization.
- Many countries prohibit the disposal of waste electronic equipment in standard waste receptacles.
- Place only discharged batteries in a battery collection container. Use electrical tape or other approved covering over the battery connection points to prevent short circuits.

H500 and SA2500 Instrument-Specific battery maintenance

Instrument run time

The instrument run time depends on power consumption, which in turn depends on the instrument measurement mode. For example, DPX™ Spectrum Display, Spectrum analyzer, and audio demodulation measurements consume more power than other measurements because they are continuously acquiring data.

With two new, fully charged batteries, you can run the DPX Spectrum Display measurement for approximately four hours, or the Spectrum analyzer measurement for five to six hours. Both of these run times are with the instrument power management mode disabled. Enabling instrument power management increases the instrument run time.

Battery aging and the increasing number of charge/discharge cycles causes the battery charge capacity to decrease, which in turn decreases the instrument run time.

The instrument uses one battery at a time. The battery with the lowest remaining capacity is used first.

Battery charge time

With the instrument powered on, it can take more than 20 hours to fully charge two batteries from a fully discharged state. The exact charge time depends on which measurements are running. When the instrument is powered off, it will take about 10 hours to fully charge two batteries.

Checking the battery charge status

1. Double-tap the **Power Management** icon in the system tray to open the **Power Management** dialog box. The system tray shows the battery icon when the instrument is operating from batteries, and a power plug icon when the instrument is operating from an external power supply.

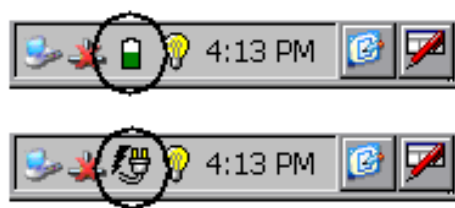

2. Tap the **Batteries** tab. This tab shows the charge level of each battery, the estimated remaining run time for the in-use battery (with the current measurement settings), and the battery calibration status. The instrument uses one battery at a time: the battery with the lowest remaining capacity is used first.

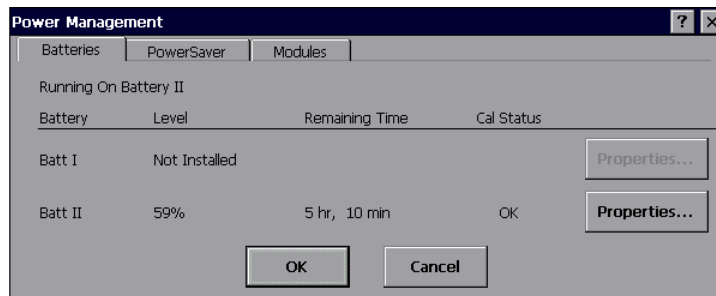

Each battery contains circuitry that monitors the charge level and estimated remaining run time. This circuit becomes uncalibrated after several partial discharge and charge cycles. When the Cal Status is **Uncalibrated**, the reported level and remaining time are not accurate, which means that the

battery is not calibrated. See the *Calibrating a Battery* section in this document.

3. Tap the **Properties** button adjacent to a battery listing to show that battery's Design Capacity, Serial Number and the Manufacturer Date. Use the serial number to identify and keep track of each battery's charge and capacity history.



Calibrating a battery

To calibrate a battery, you must first fully charge, then fully discharge, and finally fully charge the battery to reset the internal battery monitoring circuitry.

Fully charging a battery.

NOTE. During charging, keep the instrument environment temperature between 0 °C and 45 °C (32 °F and 113 °F), and the relative humidity between 0% and 80%.

1. Install the single battery that you want to charge.
2. Connect the external power adaptor, but do not power up the instrument. The BATTERIES CHARGER LED on the front panel should be lit, indicating that the instrument is charging the battery. If the BATTERIES CHARGER LED on the front panel is not lit, check the following:
 - The external power adaptor plug is fully seated in the instrument external power connector
 - There is power being supplied to the external power adaptor
 - The battery is fully seated in the instrument battery compartment
3. When the battery is fully charged, the BATTERIES CHARGER LED on the front panel turns off.
4. Power on the instrument and double-tap the **Power Management** icon in the system tray.
5. Verify that the Level field shows **Fully Charged** for the installed battery.

Fully discharging a battery.

NOTE. During battery discharge, keep the instrument environment temperature between $-10\text{ }^{\circ}\text{C}$ and $50\text{ }^{\circ}\text{C}$ ($14\text{ }^{\circ}\text{F}$ and $122\text{ }^{\circ}\text{F}$), and the relative humidity between 0% and 80%.

1. Disconnect the external power adaptor.
2. Install the single battery that you want to discharge.
3. Power on the instrument and a measurement application.
4. Double-tap the **Power Management** icon in the system tray.
5. Tap the **Power Saver** tab and select **No Power Saver actions**.
6. Set the instrument to a high-power-consumption measurement such as DPX Spectrum.
7. Let the instrument and measurement run. The instrument automatically shuts down when the battery is fully discharged. The battery is now completely discharged.

When to replace a battery

Record the date, battery serial number, charge time and run time when you start using a new instrument, or when you install new batteries. Set up a schedule to check and record the battery charge and calibration status. See the *Checking the Battery Charge Status* section in this document.

Compare the charge time and instrument run times with those for new batteries at least every six months. When any of the following behaviors occur, you should consider replacing your batteries:

- It takes significantly longer (>150%) to charge used batteries than it does to charge new batteries.
- The BATTERIES CHARGER LED on the front panel does not stay on continuously while the batteries are charging.
- After the battery is fully charged, the instrument run time is significantly shorter (<80%) with older fully-charged batteries than it is with new batteries.
- A charge cycle never completes.
- The Power Management Batteries tab does not show a **Fully Charged** status after a charge cycle.
- The battery is more than three years old.

Repackaging for shipment



CAUTION. *Remove rechargeable battery packs from the instrument before shipping and store the batteries in an approved area. (See page 59, Lithium-Ion battery maintenance.)*

To ship the instrument for repair, use the original packaging container if possible. If the container is unfit for use or not available, use the metal carrying case if available, or, repack the instrument as follows:

1. Use a carton with a test strength of no less than 80 kg (175 lbs).
2. Surround the instrument with protective polyethylene sheeting.
3. Cushion the instrument on all sides with at least two inches of tightly packed urethane foam or other packing material.
4. Seal the carton with shipping tape or an industrial stapler.

Replaceable parts

This section contains a list of the replaceable parts for the H500 and the SA2500 Spectrum Analyzers. Use this list to identify and order replacement parts.

Parts ordering information

Changes to Tektronix products are sometimes made to accommodate improved components as they become available and to give you the benefit of the latest improvements. Therefore, when ordering parts, it is important to include the following information in your order:

- Part number
- Instrument type or model number
- Instrument serial number
- Instrument modification number, if applicable

Using the replaceable parts list

This section contains a list of the mechanical and/or electrical components that are replaceable for the H500 and the SA2500 Spectrum Analyzer. Use this list to identify and order replacement parts. The following table describes each column in the parts list.

| Column | Column name | Description |
|---------|----------------------|--|
| 1 | Fig. & index number | Items in this section are referenced by figure and index numbers to the exploded view illustrations that follow. |
| 2 | Part number | Use this part number when ordering replacement parts from Tektronix. |
| 3 and 4 | Serial number | Column three indicates the serial number at which the part was first effective. Column four indicates the serial number at which the part was discontinued. No entry indicates the part is good for all serial numbers. |
| 5 | Qty | This indicates the quantity of parts used. |
| 6 | Name and description | An item name is separated from the description by a colon (:). Because of space limitations, an item name may sometimes appear as incomplete. Use the U.S. Federal Catalog handbook H6-1 for further item name identification. |

Abbreviations Abbreviations conform to American Abbreviations National Standard ANSI Y1.1-1972.



Figure 2: Module and cover replaceable parts

| Fig. & Index number | Part number | Serial number effective | Serial number discont'd | Qty | Description |
|---------------------|-------------|-------------------------|-------------------------|-----|---|
| 5-1 | | | | | Module and mainframe |
| -1 | 129-1650-xx | | | 4 | SPACER, POST; 8-32 X .975 LG |
| -2 | 200-5048-xx | | | 1 | COVER,COSMETIC; MODULE CHASSIS; SAFETY CONTROLLED |
| -3 | 129-1649-xx | | | 4 | SPACER, POST; 8-32, 2.350 LG |

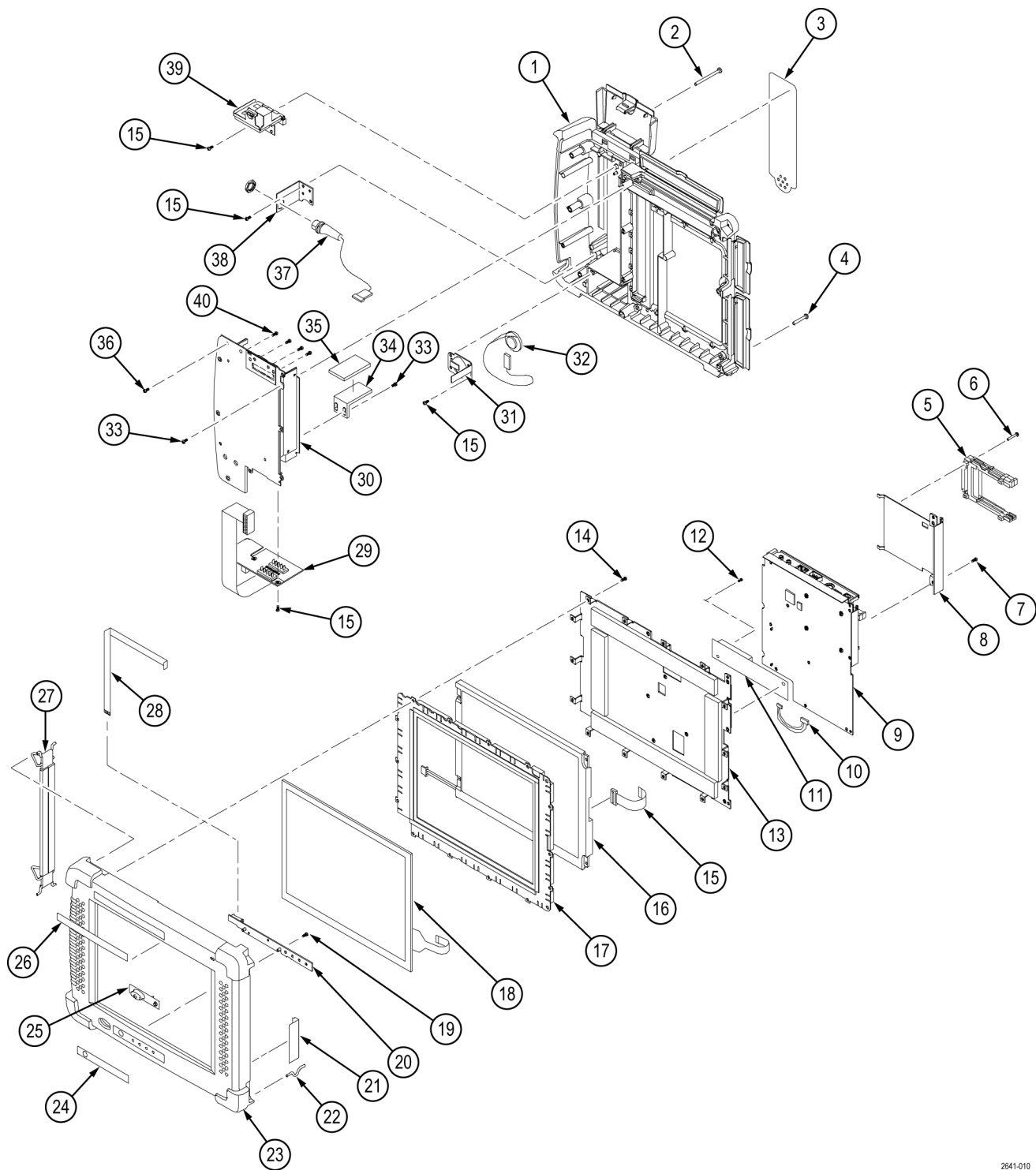

2641-010

Figure 3: Mainframe replaceable parts

| Fig. & index number | Tektronix part number | Serial no. effective | Serial no. discont'd | Qty. | Name & description |
|---------------------|-----------------------|----------------------|----------------------|------|--|
| 5-2-1 | 202-0370-02 | | | 1 | CASE, REAR:OVERMOLD ASSY,13.494 X 11.381 X 3.529 |
| -2 | 211-0530-xx | | | 3 | SCREW, MACHINE:6-32 X 1.750,PNH,STL CD PL,POZ |
| -3 | 335-1928-xx | | | 1 | MARKER, IDENT:REAR PANEL SAFETY LABEL |
| -4 | 211-0628-xx | | | 5 | SCREW, MACHINE:6-32 X 1.125,PNH,SST POZ |
| -5 | 131-6867-xx | | | 1 | CONN, HDR:SMD, MALE,RTANG,68 POS,PCMCIA,DUAL |
| -6 | 211-1095-xx | | | 4 | SCREW, MACHINE:2-56 X 0.625L, PNH, PHL, STL, ZN PL |
| -7 | 211-0747-xx | | | 9 | SCREW, MACHINE; 6-32 X 0.188, PNH, STL, CDPL |
| -8 | 407-4924-xx | | | 1 | BRACKET; DRIVE MODULE, 0.040 AL |
| | 348-1942-xx | | | 1 | RF ABSORBER, 3.320 X 2.625 (Attaches to back of 407-4924-xx) |
| -9 | 671-5609-xx | | | 1 | CIRCUIT BD ASSY: CPU, TESTED |
| -10 | 174-4776-xx | B010000 | B049999 | 1 | CABLE ASSY, BACKLIGHT INVERTER |
| | 174-6744-xx | B050000 | | 1 | CABLE ASSY, DISPLAY BACKLIGHT |
| -11 | 119-6806-xx | B010000 | B049999 | 1 | CIRCUIT BD ASSY, BACKLIGHT INVERTER |
| | 878-1181-xx | B050000 | | 1 | PCB, BACKLIGHT DRIVER BOARD |
| -12 | 211-0069-xx | | | 2 | SCREW, MACHINE; 2-56 X 0.125,PNH,STL CRM PL,POZ |
| -13 | 407-4926-xx | | | 1 | BRACKET, DISPLAY COVER; AL |
| -14 | 211-0722-xx | | | 29 | SCREW, MACHINE; 6-32 X 0.250,PNH,STL,CDPL,T-15 TORX |
| -15 | 174-5592-xx | | | 1 | CABLE ASSEMBLY; DISPLAY |
| -16 | 119-7495-xx | B010000 | B049999 | 1 | DISPLAY MODULE; LCD; 640 X 480,10.4 IN DIAGONAL |
| | 119-8433-xx | B050000 | | 1 | DISPLAY MODULE; LCD; 640 X 480, 10.4 IN DIAGONAL, TRANFLECTIVE, TFT, LED BACKLIGHT |
| -17 | 407-4994-xx | | | 1 | BRACKET: LCD COLOR, 8.5 X 10.65,0.300 AL |
| -18 | 119-6948-xx | | | 1 | TOUCH SCREEN: TOUCH PANEL ASSEMBLY, 8-WIRE |
| -19 | 211-0324-xx | | | 2 | SCR,ASSEM WSHR; 4-40 X 0.188,PNH,SST,PASS,T-9 TORX |
| -20 | 671-4682-xx | | | 1 | CIRCUIT BD ASSY; FRONT, TESTED |
| -21 | 407-4923-xx | | | 1 | BRACKET; FLOPPY BAY, BLACK ANODIZE, 0.040 AL |
| -22 | 344-0568-xx | | | 2 | CLIP: ACCESSORY CASE,16 GA WIRE,BLACK OXIDE COAT |
| -23 | 202-0405-xx | | | 1 | CASE, FRONT:OVER MOLD ASSY,12.786 X 9.903 X 1.2,BLACK |
| -24 | 334-9863-xx | | | 1 | MARKER, IDENT: LABEL, MKD RESET,FRONT,LEXAN |
| -25 | 260-2716-xx | | | 1 | SWITCH, KEYPAD: FRONT ELASTOMER MAT, PLASTIC |
| -26 | 335-3082-xx | | | 1 | MARKER, IDENT, H500 |
| | 335-3083-xx | | | 1 | MARKER, IDENT, SA2500 |
| -27 | 367-0516-xx | | | 1 | HANDLE, STRAP: HOLDING,W/VELCRO ADJUSTMENT |
| -28 | 174-4777-xx | | | 1 | CA ASSY, SP: FLAT FLEX,IDC,12 CON,0.039 CTR |
| -29 | 664-5633-xx | | | 1 | CKT BD SUBASSY: BATTERY CONNECTOR |
| -30 | 386-7408-xx | | | 1 | PANEL, BATTERY: 4.600 X 8.835,0.063 AL |
| -31 | 407-4610-xx | | | 1 | BRACKET: SPEAKER,1.45 X 1.45 L,0.050 AL |
| -32 | 119-6811-xx | | | 1 | SPEAKER: DYNAMIC, 28MM DIA,8 OHM,600-7KHZ |
| -33 | 211-0722-xx | | | 7 | SCREW, MACHINE; 6-32 X 0.250,PNH,STL,CDPL,T-15 TORX |
| -34 | 407-5007-xx | | | 1 | BRACKET; ANGLE, THERMAL PAD |

Replaceable parts

| Fig. & index number | Tektronix part number | Serial no. effective | Serial no. discount'd | Qty. | Name & description |
|--------------------------------|------------------------------|-----------------------------|------------------------------|-------------|--|
| -35 | 342-1127-xx | | | 1 | INSULATOR, MISC, THERMAL; BATTERY, 0 .125 THICK |
| -36 | 211-0722-xx | | | 4 | SCREW, MACHINE; 6-32 X 0.312,FLH100,STL,CDPL,T-10 |
| -37 | 174-4774-xx | | | 1 | CABLE ASSY: DISCRETE, CPD,3,22 AWG, (DC JACK) |
| -38 | 407-4686-xx | | | 1 | BRACKET: DC JACK,1.175 X 1.675 X 1.130,0.050 AL |
| -39 | 214-4951-xx | | | 1 | HINGE ASSEMBLY: 0.024 THK, SSSL, NICKEL PLATE |
| -40 | 211-0718-00 | | | 4 | SCREW, MACHINE; 6-32 X 0.312, FLH100, STEEL, ZINC FINISH, T-10 TORX DR |

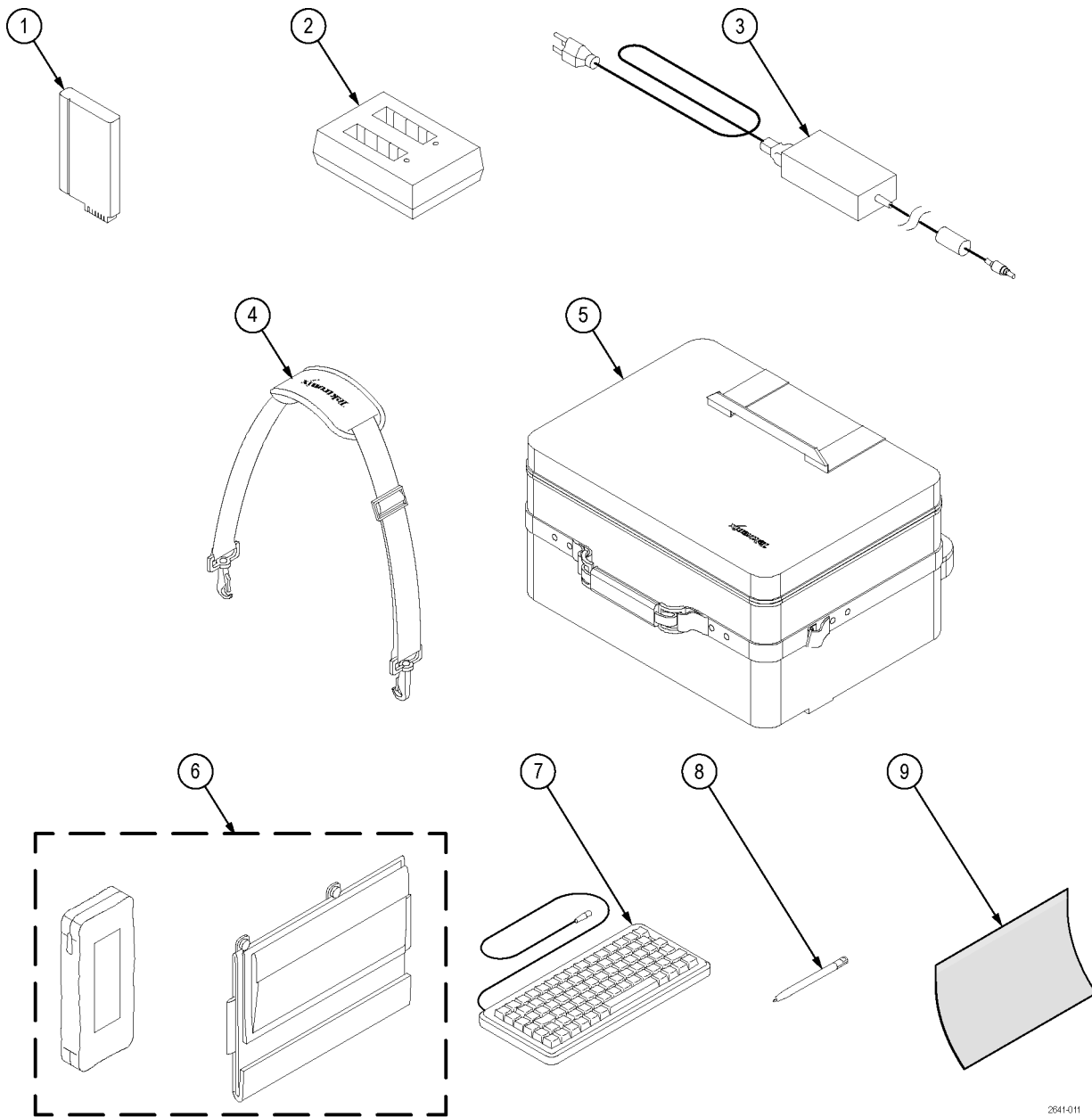

2641-011

Figure 4: H500 and SA2500 accessories

Replaceable parts

| Fig. & index number | Tektronix part number | Serial no. effective | Serial no. discont'd | Qty. | Name & description |
|---------------------|-----------------------|----------------------|----------------------|------|---|
| 5-3-1 | 146-0151-0x | | | 1 | BATTERY; LITHIUM ION, RECHARGEABLE; 10.8V, 7200MAH, SMBUS, RECESSED TERMINALS |
| -2 | 119-6030-00 | | | 1 | BATTERY CHARGER: 2-SLOT EXTERNAL CHARGER, 10MA-3A SMBUS, SBS3002 |
| -3 | 119-7288-0x | | | 1 | POWER SUPPLY; EXTERNAL; 65W, 90-264 VAC, 47-63HZ IN; 24 VDC, 2.7A OUT |
| -4 | 367-0518-00 | | | 1 | HANDLE, STRAP: SHOULDER, W/CLIPS |
| -5 | 016-1775-00 | | | 1 | CASE, CARRYING: TRANSPORTATION SOFT SHELL |
| — | 016-1889-00 | | | 1 | CASE, CARRYING: HAND, POLYETHYLENE, 24L X 16W X 13H EXTERIOR, 17L X 13W X 9H INTERIOR, FOAM DICE CUT LAYER PADS |
| -6 | 348-1661-00 | | | 1 | STAND, TILT: ACRYLIC/ALUMINUM COVERED W/CORDURA,W/ACCESSORY POUCH |
| -7 | 118-9402-00 | | | 1 | KEYBOARD ASSY: 83 KEY NOTEBOOK KEYBOARD, IBM AT OR PS/2 COMPATIBLE, GRAY |
| -8 | 119-6107-00 | | | 1 | STYLUS: STYLUS FOR TOUCH SCREEN, T1100 |
| -9 | 016-1882-00 | | | 5 | COVER: PROTECTIVE, TOUCH PANEL, 3M POLYTHYLENE TAPE, CLEAR |
| — | 012-1588-00 | | | 1 | CABLE, ELEC: PC INTERFACE |
| — | 012-1379-00 | | | 1 | CABLE ASSEMBLY:RS232, 76.0 L ,9, 24 AWG DB9 FEMALE X DB9 FEMALE, SERIAL NULL MODEM |
| — | 174-4401-00 | | | 1 | CABLE ASSY,I/O; USB, 26 AWG, 3 FT, A TO B, MALE, BLACK |
| — | 077-0786-XX | | | 1 | MANUAL, TECH; SERVICE, H500 & SA2500, PDF ONLY |
| — | 116-0996-00 | | | 1 | DISK DRIVE;PCMCIA;128MB, TYPE II, ATA FLASH CARD, 2.5MS ACCESS, CARD BUS |
| — | 116-0997-00 | | | 1 | MODEM:V.90,PC CARD 56K-GLOBAL-FREEDOM,5660 |
| — | 116-0998-00 | | | 1 | ETHERNET CARD:STANDARD LP-E LOW POWER ETHERNET CARD,EA0911-101 |
| — | 116-0999-00 | | | 1 | PRINTER:HP DESKJET 340CBI PORTABLE PRINTER,PARALLEL INTERFACE,C2671A |
| — | 161-0310-00 | | | 1 | CA ASSY,PWR:3,18 AWG,BLACK,250V/2.5A,STR,118L,RECP IEC320 C5 X NEMA 5-15P,US |
| — | 161-0311-00 | | | 1 | CA ASSY,PWR:3,250V/2.5A,STR,IEC320 C5,EUROPEAN,BLACK |
| — | 161-0312-00 | | | 1 | CABLE ASSY,PWR:3,1.0MM SQ,250V/2.5A,STR,RECP IEC320 C5,UNITED KINGDOM,BLACK |
| — | 161-0313-00 | | | 1 | CA ASSY, PWR:3,0.75MM SQ,BLACK,250V/2.5A,STR,RECP IEC320 C5, AUSTRALIAN |
| — | 161-0314-00 | | | 1 | CA ASSY,PWR:3,0.75MM SQ,BLACK,250V/2.5A,STR, RECP IEC320 C5,SWISS |
| — | 161-0315-00 | | | 1 | CA ASSY, PWR:3,1.25MM SQ,250V/2.5A,STR,RECP IEC320 C5,JAPANESE,T-MARK,BLACK |
| — | 161-0318-00 | | | 1 | CABLE ASSY,PWR; 3,18 AWG,BLACK,250V,7.5A,STR,IEC320 C5,3C CERTIFICATION,CHINA |
| — | 436-0416-00 | | | 1 | SHELF,UTILITY; MAGNETIC,11.5 H X 15.0 W X 0.25 D,SAFETY CONTROLLED |

Specifications

This section lists the electrical, environmental, and physical specifications for the H500 and SA2500 Spectrum Analyzers. All specifications are guaranteed unless labeled “Typical.” Typical specifications are provided for your convenience and are not guaranteed.

Table 27: General performance characteristics

| Characteristic | Description |
|--------------------------------------|--|
| RF Input | |
| Operating Frequency Range | 10 kHz – 6.2 GHz Operating Range for some features may be restricted. If so, the restricted range is defined with the relevant feature. |
| Maximum Operating Input Level | +20 dBm peak envelope power This is the maximum input level at which the instrument will meet its performance specifications. For a signal without any amplitude variation, peak envelope power = RMS. |
| Maximum Input Power without Damage | 50 W rms below 3.2 GHz 15 W rms between 3.2 GHz and 6.2 GHz |
| IF Output | |
| Output Impedance | 50 Ω |
| IF Center Frequency | 140 MHz, non-inverted |
| IF 3 dB Bandwidth | 24 MHz nominal |
| IF Output Level | -12 dBm @ 1.0 GHz -12 dBm @ 1.2 GHz -10 dBm @ 1.6 GHz -11 dBm @ 4.35 GHz -16 dBm @ 5.0 GHz -22 dBm @ 5.75 GHz 0 dBm CW signal applied to the input, instrument reference level set to 0 dBm, room temperature. |
| IF Output Level Accuracy, Typical | ± 3.5 dB for a CW input signal, 0 dBm input, 1 GHz input frequency, 0 dBm reference level, room temperature |
| IF Output Flatness, Typical | ± 1.5 dB up to ± 3 MHz from center frequency ± 3 dB up to ± 10 MHz from center frequency |
| Internal Timebase | |
| Error, Factory Calibration Corrected | ± 0.5 PPM from 0 °C to 50 °C ± 1.0 PPM aging/year Twenty minute warm-up period required to meet accuracy specification |

Table 27: General performance characteristics (cont.)

| Characteristic | Description |
|---|---|
| Error, GPS corrected, Typical | $\pm (10 \text{ Hz} + 0.01 \text{ ppm})$ |
| External Reference Input | |
| Impedance | 1500 Ω |
| Frequency Range | 1 MHz up to 20 MHz \pm 1 PPM in 1 MHz steps |
| Input Level Range | -15 dBm to +15 dBm, 1 MHz to 15 MHz -10 dBm to +15 dBm, 16 MHz to 20 MHz dBm levels assume 50 Ω source |
| Trigger | |
| Timing/Trigger External Trigger Input Characteristics | Impedance: 10 k Ω Minimum High Threshold: 2.0 V Maximum Low Threshold: 0.8 V Minimum High Time: 10 ns Minimum Low Time: 10 ns Maximum Input Level without Damage: \pm 5 V peak continuous Coupling: DC |
| Acquisition Mode | Single or Continuous, Free Run or Triggered Trigger disabled during Audio Demod, Signal Strength, and DPX measurements |
| Trigger Source | IF Level or Timing/Trigger Input |
| Trigger Types | Trigger on rising edge, falling edge, above threshold level, or below threshold level |
| Trigger Delay | Range: 0 to 60 seconds Resolution: 1 μ s |
| Trigger Position | Range: 0 to 100% Resolution: 1% |
| IF Level Trigger | The IF Level trigger compares the digitized time-domain data-stream level against the threshold level setting. |

Table 27: General performance characteristics (cont.)

| Characteristic | Description |
|-------------------------|---|
| Trigger Threshold | Range: -160 dBm to +20 dBm Resolution: 1 dB |
| Trigger Bandwidth Range | 5 kHz to 20 MHz in 1-2-5 sequence 10 MHz < Span ≤ 20 MHz: trigger BW = 20 MHz 5 MHz < Span ≤ 10 MHz: trigger BW = 10 MHz 2 MHz < Span ≤ 5 MHz: trigger BW = 5 MHz 1 MHz < Span ≤ 2 MHz: trigger BW = 2 MHz 500 kHz < Span ≤ 1 MHz: trigger BW = 1 MHz 200 kHz < Span ≤ 500 kHz: trigger BW = 500 kHz 100 kHz < Span ≤ 200 kHz: trigger BW = 200 kHz 50 kHz < Span ≤ 100 kHz: trigger BW = 100 kHz 20 kHz < Span ≤ 50 kHz: trigger BW = 50 kHz 10 kHz < Span ≤ 20 kHz: trigger BW = 20 kHz 5 kHz < Span ≤ 10 kHz: trigger BW = 10 kHz 2.5 kHz < Span ≤ 5 kHz: trigger BW = 5 kHz Spectrum mode only: Span ≤ 2.5 kHz: trigger BW = 2.5 kHz |

Table 28: Spectrum analyzer characteristics

| Characteristic | Description |
|------------------------------------|---|
| Center Frequency | |
| Range | 10 kHz to 6.2 GHz, preamp off 10 MHz to 6.2 GHz, preamp on |
| Setting Resolution | 1 Hz |
| Span | |
| Range | 1 kHz to 6.2 GHz |
| Setting Resolution | 1 Hz |
| Swept Spans (Wide Scanning) | |
| Span Range | 20 MHz to 6 GHz |
| Spectrums per Second | 61, typical |
| Scan Speed | 1240 MHz per second, typical |
| Resolution Bandwidth | |
| Range | 10 Hz to 3 MHz (Manual RBW) 10 Hz to 1 MHz (Auto RBW) |
| Setting Resolution | 1 Hz |
| Spectral Purity | |

Table 28: Spectrum analyzer characteristics (cont.)

| Characteristic | Description |
|--|--|
| Displayed Average Noise Level, Preamp On | -153 dBm, 10 MHz to 2 GHz, 10 Hz RBW -152 dBm, 2 GHz to 4 GHz, 10 Hz RBW -151 dBm, 4 to 5 GHz, 10 Hz RBW -145 dBm, 5 to 6.2 GHz, 10 Hz RBW Reference Level \leq (DANL + 90 dB) |
| Phase Noise | ≤ -95 dBc/Hz @ 10 kHz offset ≤ -95 dBc/Hz @ 20 kHz offset ≤ -95 dBc/Hz @ 30 kHz offset ≤ -97 dBc/Hz @ 100 kHz offset ≤ -110 dBc/Hz @ 1 MHz offset |
| Residual Spurious, Preamp Off | ≤ -90 dBm, 0 dBm attenuator setting Exception frequencies: 9 MHz to 19 MHz center frequency 3464 MHz center frequency 4592 MHz center frequency 5374 MHz to 5378 MHz center frequency 6160 MHz center frequency |
| Residual Spurious, Preamp On | ≤ -105 dBm, 0 dBm attenuator setting Exception frequencies: 9 MHz to 19 MHz center frequency 5374 MHz to 5378 MHz center frequency |
| Third Order IMD | ≤ -70 dBc for two tones at or below the reference level, preamp off, all gain settings Auto-coupled |
| Second Harmonic | ≤ -60 dBc for a single tone at or below the reference level, preamp off, all gain settings Auto-coupled |
| Input Related Spurious | ≤ -70 dBc except for $F_{in} = 2.282$ GHz \pm 20 MHz The reference for 'dBc' for this specification is the total power of all signals present at the input of the instrument regardless of the current span |
| Input Related Spurious, exception frequencies, Typical | ≤ -55 dBc except for $F_{in} = 2.282$ GHz \pm 20 MHz The reference for "dBc" for this specification is the total power of all signals present at the input of the instrument regardless of the current span |
| Third Order Intercept | $\geq +7$ dBm, 0 dB Input Attenuation, Preamp Off |

Table 28: Spectrum analyzer characteristics (cont.)

| Characteristic | Description |
|-----------------------------------|--|
| Spectral Display Amplitude | |
| Reference Level Range and Units | Range: +20 dBm to -160 dBm Units: dBm, dBmV, dBuV, dBV, dBW, V, W |
| Marker Power Accuracy | ± 1.75 dB, -50 dBm \leq input \leq +20 dBm, preamp off ± 3.0 dB, -80 dBm \leq input $<$ -50 dBm, preamp on, above 10 MHz ± 3.75 dB, -120 dBm \leq input $<$ -80 dBm, preamp on, above 10 MHz Use peak detector for CW signals Accuracy guaranteed for CW signals and span set to 20 MHz or less |
| Display | |
| Display Modes | Normal - updates display with each new result Max Hold - updates displayed point only if new point $>$ old Min Hold - updates displayed point only if new point $<$ old Max/Min Hold - displays a vertical bar between Max Hold and Min Hold Average - displays average of N (specified by user) acquisitions Average is calculated as follows: Last N values are saved in memory; when a new result is available, the earliest result of the N stored values is discarded, the new result is added to the stored values, and a new average is calculated from the stored values If the number of results is less than N, then all of the results are averaged together |
| Number of Averages | $1 \leq N \leq 200$ |

Table 29: DPX measurement processing characteristics

| Characteristic | Description |
|--|---|
| Spectrum Processing Rate, Typical | H500 (or SA2500 with Option EP1): 10,000 per second (span independent) SA2500: 2,500 per second (span independent) |
| Minimum Signal Duration for 100% Probability of Intercept, Typical | H500 (or SA2500 with Option EP1): 125 μ s SA2500: 500 μ s |
| Span Range | 5 kHz to 20 MHz |
| RBW Settings | RBW = Span/200 |

Table 30: Spectrogram (Rising Raster) measurement processing characteristics

| Characteristic | Description |
|--|---------------------------------|
| Spectrum Processing Rate | 20 spectrums per second nominal |
| Minimum Signal Duration for Time Measurement | 20 ms typical |
| Span Range | 5 kHz to 20 MHz |

Table 31: General purpose RF measurement characteristics

| Characteristic | Description |
|---|---|
| General Purpose RF Channel Power Measurement | |
| Measurement Bandwidth Range | 1 kHz – 20 MHz |
| Accuracy | ≤1.2 dB; +20 dBm to –60 dBm; Resolution BW < 100 kHz +20 dBm to –40 dBm; Resolution BW ≥ 100 kHz 1 MHz to 3.2 GHz, preamp off ≤2.4 dB; –60 dBm to –75 dBm; Resolution BW < 100 kHz –40 dBm to –55 dBm; Resolution BW ≥ 100 kHz 10 MHz to 3.2 GHz, preamp on ≤1.8 dB; +20 dBm to –50 dBm; Resolution BW < 100 kHz +20 dBm to –40 dBm; Resolution BW ≥ 100 kHz 3.2 GHz to 6.2 GHz, preamp off ≤3 dB; –50 dBm to –75 dBm; Resolution BW < 100 kHz –40 dBm to –55 dBm; Resolution BW ≥ 100 kHz 3.2 GHz to 6.2 GHz, preamp on Specifications apply for default control settings (Auto RBW, Auto Level) |
| Occupied Bandwidth Measurement | |
| Percent Power Inclusion Range | 50% - 100% in 1% steps |
| RF Field Strength | |
| Channel Bandwidth Range | Same as Channel Power |
| Accuracy | Same as Channel Power |

Table 32: Amplitude vs. Time measurement characteristics

| Characteristic | Description |
|-------------------------------|--|
| Center Frequency | |
| Range | Minimum center frequency = 10 kHz + Span / 2, preamp off Minimum center frequency = 10 MHz, preamp on Maximum center frequency = 6.2 GHz |
| Resolution | 1 Hz |
| Span | |
| Range | 5 kHz to 20 MHz in 1-2-5 sequence Sample rate is automatically set based on the span selection |
| Acquisition Length | |
| Range | 1024 to 1024000 samples 36 μ s to 149 seconds, depending on span and number of samples Span setting and number of samples selected determine the acquisition length Sample rate is automatically set based on span selection |
| Time Display Amplitude | |
| Reference Level | +20 dBm to -160 dBm |
| Range and Units | dBm, dBmV, dBuV, dBV, dBW, V, W |
| Marker Power | ± 1.8 dB, -50 dBm \leq input \leq +20 dBm, preamp off |
| Accuracy | ± 3.0 dB, -75 dBm \leq input $<$ -40 dBm, preamp on, above 10 MHz |
| Display | |
| Detector Types | Average: One display point represents the average value of a group of data points +Peak: One display point represents the maximum value of a group of data points -Peak: One display point represents the minimum value of a group of data points +Peak/-Peak: One vertical bar represents the maximum and minimum values of a group of data points |
| Trace Types | Normal: updates display with each new result Max Hold: updates displayed point only if new point $>$ old Min Hold: updates displayed point only if new point $<$ old Max/Min Hold: displays a vertical bar between Max Hold and Min Hold Average: displays average of N (specified by user) acquisitions |
| Number of Averages | $1 \leq N \leq 200$ |
| Export I/Q Data | I/Q data from can be exported in the following formats: IQT: in-phase and quadrature phase data for post-processing with RSAVu CSV: comma-separated values in ASCII format MAT: Matlab®-compatible file format |

Table 33: Signal analysis and monitoring characteristics

| Characteristic | Description |
|-------------------------------------|---|
| AM Demodulation | Provides an audio output signal after AM demodulation of the user-selected signal |
| Measurement Frequency | As previously selected |
| Minimum Input Signal Level, Typical | -100 dBm |
| Audio Measurement Bandwidth | 8 kHz |
| FM Demodulation | Provides an audio output signal after FM demodulation of the user-selected signal |
| Measurement Frequency | As previously selected |
| Minimum Signal Level, Typical | -100 dBm |
| Maximum Signal Deviation | Up to 100 kHz |
| Audio Measurement Bandwidth | 8 kHz, 15 kHz, 75 kHz, or 200 kHz |
| Maximum Audio Output Bandwidth | 15 kHz |
| Signal Strength Indicator | Provides both an audio tone and a visual display that are related to the strength of the user selected signal |
| Input Signal Level | -120 dBm, minimum |
| Measurement Frequency | As previously selected |
| Measurement Bandwidth | Up to 20 MHz, dependent upon span and RBW setting |
| Tone Type | Variable beep rate or variable frequency |
| Update Rate, Typical | 10 per second |

Table 34: Environmental characteristics

| Characteristic | Description |
|----------------|---|
| Temperature | Operating: 0 °C to +50 °C specified performance, -10 °C to +50 °C, typical Nonoperating: -40 °C to +60 °C The temperature specs above are modified with the following options installed: Li-Ion Batteries: Charge 0 °C to +45 °C, Storage -20 °C to +60 °C |
| Humidity | Operating and Nonoperating: 5% to 95% relative humidity (RH) at up to +30 °C, 5% to 45% RH above +30 °C up to +50 °C, noncondensing |
| Altitude | Operating: Up to 4,600 meters (15,092 feet) Nonoperating: Up to 12,192 meters (40,000 feet) |

Table 35: Physical characteristics

| Characteristic | Description |
|----------------|---|
| Dimensions | Height: 25.5 cm. (10.0 in) Width: 33 cm. (13 in) Depth: 12.5 cm. (4.8 in) |
| Weight | 6.0 kg (13.25 lbs): instrument and 1 battery |

Table 36: Miscellaneous characteristics

| Characteristic | Description |
|---|-------------|
| Recommended Instrument Calibration Interval | 1 year |