

KPXI 3U Instrument Chassis

User's Manual

KPXI-SYS-900-01 Rev. A / January 2007

ECA 42912

WARRANTY

Keithley Instruments, Inc. warrants this product to be free from defects in material and workmanship for a period of 1 year from date of shipment.

Keithley Instruments, Inc. warrants the following items for 90 days from the date of shipment: probes, cables, rechargeable batteries, diskettes, and documentation.

During the warranty period, we will, at our option, either repair or replace any product that proves to be defective.

To exercise this warranty, write or call your local Keithley Instruments representative, or contact Keithley Instruments headquarters in Cleveland, Ohio. You will be given prompt assistance and return instructions. Send the product, transportation prepaid, to the indicated service facility. Repairs will be made and the product returned, transportation prepaid. Repaired or replaced products are warranted for the balance of the original warranty period, or at least 90 days.

LIMITATION OF WARRANTY

This warranty does not apply to defects resulting from product modification without Keithley Instruments' express written consent, or misuse of any product or part. This warranty also does not apply to fuses, software, non-rechargeable batteries, damage from battery leakage, or problems arising from normal wear or failure to follow instructions.

THIS WARRANTY IS IN LIEU OF ALL OTHER WARRANTIES, EXPRESSED OR IMPLIED, INCLUDING ANY IMPLIED WARRANTY OF MERCHANTABILITY OR FITNESS FOR A PARTICULAR USE. THE REMEDIES PROVIDED HEREIN ARE BUYER'S SOLE AND EXCLUSIVE REMEDIES.

NEITHER KEITHLEY INSTRUMENTS, INC. NOR ANY OF ITS EMPLOYEES SHALL BE LIABLE FOR ANY DIRECT, INDIRECT, SPECIAL, INCIDENTAL OR CONSEQUENTIAL DAMAGES ARISING OUT OF THE USE OF ITS INSTRUMENTS AND SOFTWARE EVEN IF KEITHLEY INSTRUMENTS, INC., HAS BEEN ADVISED IN ADVANCE OF THE POSSIBILITY OF SUCH DAMAGES. SUCH EXCLUDED DAMAGES SHALL INCLUDE, BUT ARE NOT LIMITED TO: COSTS OF REMOVAL AND INSTALLATION, LOSSES SUSTAINED AS THE RESULT OF INJURY TO ANY PERSON, OR DAMAGE TO PROPERTY.



A G R E A T E R M E A S U R E O F C O N F I D E N C E

Keithley Instruments, Inc.

Corporate Headquarters • 28775 Aurora Road • Cleveland, Ohio 44139
440-248-0400 • Fax: 440-248-6168 • 1-888-KEITHLEY (534-8453) • www.keithley.com

KPXI 3U Instrument Chassis User's Manual

©2007, Keithley Instruments, Inc.
All rights reserved.
Cleveland, Ohio, U.S.A.

Document Number: KPXI-SYS-900-01 Rev. A / January 2007

Manual Print History

The print history shown below lists the printing dates of all Revisions and Addenda created for this manual. The Revision Level letter increases alphabetically as the manual undergoes subsequent updates. Addenda, which are released between Revisions, contain important change information that the user should incorporate immediately into the manual. Addenda are numbered sequentially. When a new Revision is created, all Addenda associated with the previous Revision of the manual are incorporated into the new Revision of the manual. Each new Revision includes a revised copy of this print history page.

Revision A (Document Number KPXI-SYS-900-01) January 2007

The following safety precautions should be observed before using this product and any associated instrumentation. Although some instruments and accessories would normally be used with non-hazardous voltages, there are situations where hazardous conditions may be present.

This product is intended for use by qualified personnel who recognize shock hazards and are familiar with the safety precautions required to avoid possible injury. Read and follow all installation, operation, and maintenance information carefully before using the product. Refer to the manual for complete product specifications.

If the product is used in a manner not specified, the protection provided by the product may be impaired.

The types of product users are:

Responsible body is the individual or group responsible for the use and maintenance of equipment, for ensuring that the equipment is operated within its specifications and operating limits, and for ensuring that operators are adequately trained.

Operators use the product for its intended function. They must be trained in electrical safety procedures and proper use of the instrument. They must be protected from electric shock and contact with hazardous live circuits.

Maintenance personnel perform routine procedures on the product to keep it operating properly, for example, setting the line voltage or replacing consumable materials. Maintenance procedures are described in the manual. The procedures explicitly state if the operator may perform them. Otherwise, they should be performed only by service personnel.

Service personnel are trained to work on live circuits, and perform safe installations and repairs of products. Only properly trained service personnel may perform installation and service procedures.

Keithley Instruments products are designed for use with electrical signals that are rated Measurement Category I and Measurement Category II, as described in the International Electrotechnical Commission (IEC) Standard IEC 60664. Most measurement, control, and data I/O signals are Measurement Category I and must not be directly connected to mains voltage or to voltage sources with high transient over-voltages. Measurement Category II connections require protection for high transient over-voltages often associated with local AC mains connections. Assume all measurement, control, and data I/O connections are for connection to Category I sources unless otherwise marked or described in the Manual.

Exercise extreme caution when a shock hazard is present. Lethal voltage may be present on cable connector jacks or test fixtures. The American National Standards Institute (ANSI) states that a shock hazard exists when voltage levels greater than 30V RMS, 42.4V peak, or 60VDC are present. A good safety practice is to expect that hazardous voltage is present in any unknown circuit before measuring.

Operators of this product must be protected from electric shock at all times. The responsible body must ensure that operators are prevented access and/or insulated from every connection point. In some cases, connections must be exposed to potential human contact. Product operators in these circumstances must be trained to protect themselves from the risk of electric shock. If the circuit is capable of operating at or above 1000 volts, no conductive part of the circuit may be exposed.

Do not connect switching cards directly to unlimited power circuits. They are intended to be used with impedance limited sources. NEVER connect switching cards directly to AC mains. When connecting sources to switching cards, install protective devices to limit fault current and voltage to the card.

Before operating an instrument, make sure the line cord is connected to a properly grounded power receptacle. Inspect the connecting cables, test leads, and jumpers for possible wear, cracks, or breaks before each use.

When installing equipment where access to the main power cord is restricted, such as rack mounting, a separate main input power disconnect device must be provided, in close proximity to the equipment and within easy reach of the operator.

For maximum safety, do not touch the product, test cables, or any other instruments while power is applied to the circuit under test. ALWAYS remove power from the entire test system and discharge any capacitors before: connecting or disconnecting cables or jumpers, installing or removing switching cards, or making internal changes, such as installing or removing jumpers.

Do not touch any object that could provide a current path to the common side of the circuit under test or power line (earth) ground. Always make measurements with dry hands while standing on a dry, insulated surface capable of withstanding the voltage being measured.

The instrument and accessories must be used in accordance with its specifications and operating instructions or the safety of the equipment may be impaired.

Do not exceed the maximum signal levels of the instruments and accessories, as defined in the specifications and operating information, and as shown on the instrument or test fixture panels, or switching card.

When fuses are used in a product, replace with same type and rating for continued protection against fire hazard.

Chassis connections must only be used as shield connections for measuring circuits, NOT as safety earth ground connections.

If you are using a test fixture, keep the lid closed while power is applied to the device under test. Safe operation requires the use of a lid interlock.

If a  screw is present, connect it to safety earth ground using the wire recommended in the user documentation.

The  symbol on an instrument indicates that the user should refer to the operating instructions located in the manual.

The  symbol on an instrument shows that it can source or measure 1000 volts or more, including the combined effect of normal and common mode voltages. Use standard safety precautions to avoid personal contact with these voltages.

The  symbol on an instrument shows that the surface may be hot. Avoid personal contact to prevent burns.

The  symbol indicates a connection terminal to the equipment frame.

The **WARNING** heading in a manual explains dangers that might result in personal injury or death. Always read the associated information very carefully before performing the indicated procedure.

The **CAUTION** heading in a manual explains hazards that could damage the instrument. Such damage may invalidate the warranty.

Instrumentation and accessories shall not be connected to humans.

Before performing any maintenance, disconnect the line cord and all test cables.

To maintain protection from electric shock and fire, replacement components in mains circuits, including the power transformer, test leads, and input jacks, must be purchased from Keithley Instruments. Standard fuses, with applicable national safety approvals, may be used if the rating and type are the same. Other components that are not safety related may be purchased from other suppliers as long as they are equivalent to the original component. (Note that selected parts should be purchased only through Keithley Instruments to maintain accuracy and functionality of the product.) If you are unsure about the applicability of a replacement component, call a Keithley Instruments office for information.

To clean an instrument, use a damp cloth or mild, water based cleaner. Clean the exterior of the instrument only. Do not apply cleaner directly to the instrument or allow liquids to enter or spill on the instrument. Products that consist of a circuit board with no case or chassis (e.g., data acquisition board for installation into a computer) should never require cleaning if handled according to instructions. If the board becomes contaminated and operation is affected, the board should be returned to the factory for proper cleaning/servicing.

Table of Contents

Section	Topic	Page
1	Introduction	1-1
	Introduction.....	1-2
	KPXI-SYS-18-460X2.....	1-2
	KPXI-SYS-14-500.....	1-2
	KPXI-SYS-8-400.....	1-2
	KPXI-SYS-6-250.....	1-3
	Features.....	1-3
	Safety symbols and terms.....	1-4
	Specifications.....	1-4
	Unpacking and inspection.....	1-5
	Inspection for damage.....	1-5
	Shipment contents.....	1-5
	Instruction manual.....	1-5
	Repacking for shipment.....	1-5
2	Installation	2-1
	Introduction.....	2-2
	Power considerations.....	2-2
	Installation.....	2-2
	KPXI-SYS-18-460X2 , KPXI-SYS-8-400, and KPXI-SYS-14-500.....	2-2
	KPXI-SYS-6-250 (6 slot chassis).....	2-3
	System monitoring.....	2-3
	Rack Mounting.....	2-4
3	Backplane Overview	3-1
	Introduction.....	3-2
	System controller slot.....	3-2
	Local bus.....	3-2
	KPXI-SYS-18-460X2.....	3-2
	Star trigger slot.....	3-2
	Peripheral slots.....	3-2
	Trigger bus.....	3-2
	System reference clock.....	3-3
	KPXI-SYS-14-500.....	3-4
	Star trigger slot.....	3-4
	Peripheral slots.....	3-4
	Trigger bus.....	3-4
	System reference clock.....	3-4
	KPXI-SYS-8-400.....	3-4
	Star trigger slot.....	3-4
	Peripheral slots.....	3-4
	Trigger bus.....	3-4
	System reference clock.....	3-5
	KPXI-SYS-6-250.....	3-5
	Star trigger slot.....	3-5
	Peripheral slots.....	3-5
	Trigger bus.....	3-6
	System reference clock.....	3-6

Section	Topic	Page
4	Troubleshooting and Maintenance	4-1
	Introduction	4-2
	Troubleshooting and maintenance	4-2
	Temperature detection	4-2
	Fan hot-swap replacement	4-2
	Power supply unit hot-swap replacement	4-2
	Service Form	

List of Figures

Section	Figure	Title	Page
3	Figure 3-1	KPXI-SYS-18-460X2 PXI Local Bus and Star Trigger Routing.....	3-3
	Figure 3-2	KPXI-SYS-8-400 PXI Local Bus and Star Trigger Routing	3-5
	Figure 3-3	KPXI-SYS-6-250 PXI local bus and star trigger routing.....	3-6

This page left blank intentionally.

List of Tables

Section	Table	Title	Page
1	Table 1-1	Features.....	1-3
2	Table 2-1	System Monitoring.....	2-3
4	Table 4-1	Troubleshooting power failure.....	4-2

This page left blank intentionally.

In this section:

Topic	Page
Introduction	1-2
KPXI-SYS-18-460X2	1-2
KPXI-SYS-14-500.....	1-2
KPXI-SYS-8-400.....	1-2
KPXI-SYS-6-250.....	1-3
Features	1-3
Safety symbols and terms	1-4
Unpacking and inspection	1-5
Inspection for damage	1-5
Shipment contents	1-5
Instruction manual	1-5
Repacking for shipment.....	1-5

Introduction

Keithley Instruments KPXI-SYS series 3U PXI Instrument Chassis provide one system slot as well as multiple peripheral slots in a system. The number of slots provided is model dependent (see [Features](#)). Each model in the KPXI-SYS series 3U PXI Instrument Chassis is also equipped with a power supply. Refer to the following for an overview of each chassis model.

KPXI-SYS-18-460X2

Model KPXI-SYS-18-460X2 is an 18-slot PXI chassis providing 17 PXI peripheral expansion slots and one system slot with two PXI-to-PXI bridges. The chassis incorporates all features defined by the PXI and CompactPCI specifications. Both PXI and CompactPCI modules can be used in the chassis. An internal 10MHz reference clock is available on all 17 PXI slots. The PXI trigger bus is divided into three segments. Star trigger signals are available on slots 3 through 15.

The Model KPXI-SYS-18-460X2 is equipped with 460W + 460W redundant power units to provide reliable and easy to maintain power to the system. The status of system power supply, temperature, and cooling fans are monitored by the alarm module in the chassis. Once a failure is detected, a LED and buzzer will be actuated. The failure fans can be removed from the front panel and hot-swapped, reducing MTTR (Mean-Time-To-Repair).

The Model KPXI-CON controllers are designed specifically with the KPXI-SYS-18-460X2 in mind. With all the powerful and convenient design, the Model KPXI-SYS-18-460X2 chassis is ideal for high performance applications and a large number of I/O modules.

KPXI-SYS-14-500

The KPXI-SYS-14-500 is a 19" 3U PXI chassis providing 13 PXI peripheral slots and one system slot with one PXI-to-PXI bridge. The KPXI-SYS-14-500 is compliant with PXI and CompactPCI specifications and supports both PXI and CompactPCI modules. The internal 10MHz reference clock is available on all 13 PXI slots and the PXI trigger bus is divided into two segments with each segment consisting of 7 slots. Star trigger signals are available on slots 3 through 13. The KPXI-SYS-14-500 is equipped with a 500W ATX power supply to provide reliable power to the system. The status of system power supply, temperature, and cooling fans are monitored by an alarm module built in to the chassis. When any cooling fan fails, a LED and buzzer will be actuated. The malfunctioning fan is hot-swappable and can be removed from the front panel. The KPXI-SYS-14-500 chassis also features a compact mechanical design, which makes it shallow enough for easy cable routing while allowing air flow in the rear of the rack.

The Model KPXI-CON controllers are designed specifically with the KPXI-SYS-14-500 in mind. With its powerful design, the KPXI-SYS-14-500 chassis is ideal for measurement and automation applications.

KPXI-SYS-8-400

The Model KPXI-SYS-8-400 is a 19" 3U PXI chassis providing 7 PXI peripheral slots in a system. These chassis are compliant with PXI and CompactPCI specifications. Both PXI and CompactPCI modules can be used in the chassis. Compliant with PXI specifications, the internal 10MHz reference clock is available on all of the 7 PXI slots, as well as the star trigger functions, PXI trigger bus, and PXI local bus.

The Model KPXI-SYS-8-400 is equipped with an industrial grade 400W ATX power supply to provide reliable and cost effective power to the system. The status of system power supply, temperature, and cooling fans are monitored by the alarm module assembled in the chassis. Once a failure is detected, a LED and buzzer will be actuated. The failure fans can be removed from the front panel and are hot-swappable, which effectively reduces MTTR (Mean-Time-To-Repair).

The Model KPXI-CON controllers are designed specifically with the Model KPXI-SYS-8-400 in mind. With its powerful design, the Model KPXI-SYS-8-400 chassis is ideal for high performance and medium size applications.

KPXI-SYS-6-250

The Model KPXI-SYS-6-250 is a 3U 6-slot half-rack PXI chassis that provides one slot for a system controller and 5 slots for PXI peripherals. Both PXI and CompactPCI modules can be used in this chassis. The internal 10MHz reference clock is available on all of the 5 peripheral slots, as well as the star trigger functions, PXI trigger bus, and PXI local bus.

The Model KPXI-SYS-6-250 chassis is equipped with an industrial-grade 250W CompactPCI power supply to provide reliable power to the whole system.

The Model KPXI-CON controllers are designed specifically with the KPXI-SYS-14-500 in mind. Carry handles and rack mount brackets are included. The Model KPXI-SYS-6-250 is an ideal chassis for small, high performance applications.

Features

The Keithley Instruments KPXI-SYS series 3U PXI Instrument Chassis' features are provided in the [Table 1-1](#).

Table 1-1
Features

Model	Features	Power supply
KPXI-SYS-18-460X2	<ul style="list-style-type: none"> • Accepts both 3U PXI and CompactPCI modules • One system slot and 17 PXI/CompactPCI peripheral slots • PXI specifications Rev. 2.0 compliant • IEEE 1101.10 mechanical packaging compliant • Filtered, forced-air cooling • Temperature, voltage and fan monitoring LED • 4U high rackmount and bench top installation • Two PXI-to-PXI bridges 	<ul style="list-style-type: none"> • 460W+460W redundant power supply with universal input
KPXI-SYS-14-500	<ul style="list-style-type: none"> • Accepts both 3U PXI and CompactPCI modules • One system slot and 13 PXI/CompactPCI peripheral slots • PXI specifications Rev. 2.2 compliant • IEEE 1101.10 mechanical packaging compliant • Filtered, forced-air cooling • Temperature, voltage and fan monitoring LED • 4U high rackmount and bench top installation • Removable Fan • Temperature, Voltage, and Fan Monitoring LED 	<ul style="list-style-type: none"> • 500W ATX power supply

Table 1-1 (continued)

Features

Model	Features	Power supply
KPXI-SYS-8-400	<ul style="list-style-type: none"> • Accepts both 3U PXI and CompactPCI modules • One system slot and 7 PXI/CompactPCI peripheral slots • PXI specifications Rev. 2.0 compliant • IEEE 1101.10 mechanical packaging compliant • Filtered, forced-air cooling • Temperature, voltage, and fan monitoring LED • 4U high rackmount and bench top installation 	<ul style="list-style-type: none"> • 400W ATX power
KPXI-SYS-6-250	<ul style="list-style-type: none"> • Accepts both 3U PXI and CompactPCI modules • One system slot and 5 PXI/CompactPCI peripheral slots • PXI specifications Rev. 2.0 compliant • Filtered, forced-air cooling • Side handles and stand feet for portability • IEEE 1101.10 mechanical packaging compliant 	<ul style="list-style-type: none"> • Modular AC or DC 250W power supply

Safety symbols and terms

The following symbols and terms may be found on the Model KPXI-SYS chassis or used in this manual.

The  symbol indicates that the user should refer to the operating instructions located in the manual.

The  symbol shows that high voltage may be present on the terminal(s). Use standard safety precautions to avoid personal contact with these voltages.

The  symbol on an instrument shows that the surface may be hot. Avoid personal contact to prevent burns.

The **WARNING** heading used in this manual explains dangers that might result in personal injury or death. Always read the associated information very carefully before performing the indicated procedure.

The **CAUTION** heading used in this manual explains hazards that could damage the unit. Such damage may invalidate the warranty.

Specifications

Refer to the product data sheet for updated Keithley Instruments KPXI System 3U PXI Instrument Chassis specifications. Check the Keithley Instruments website at www.keithley.com for the latest updates to the specifications.

Unpacking and inspection

Inspection for damage

CAUTION Your KPXI-SYS series chassis contains electro-static sensitive components that can be easily be damaged by static electricity.

Therefore, handle the chassis on a grounded anti-static mat. The operator should be wearing an anti-static wristband, grounded at the same point as the anti-static mat.

Keithley Instruments KPXI System 3U PXI Instrument Chassis was carefully inspected electrically and mechanically before shipment.

Inspect the chassis carton for obvious damages. Shipping and handling may damage the chassis. Make sure there is no shipping and handling damage on the module's carton before continuing.

After opening the chassis carton, extract the chassis and place it only on a suitable surface. Save the original packing carton for possible future shipment.

Again, inspect the chassis for damages. Report any damage to the shipping agent immediately.

Shipment contents

The following items are included with every Model KPXI-SYS series order:

- Keithley Instruments KPXI System 3U PXI Instrument Chassis
- CD containing required software and manuals
- Power cord

Instruction manual

A CD-ROM containing this User's Manual and required software is included with each Keithley Instruments KPXI-SYS series chassis order. If a hardcopy of the Keithley Instruments KPXI-SYS series User's Manual is required, you can order the Manual Package (Keithley Instruments Part Number KPXI-SYS-900-01). The Manual Package includes an instruction manual and any pertinent addenda.

Always check the Keithley Instruments website at www.keithley.com for the latest revision of the manual. The latest manual can be downloaded (in PDF format) from the website.

Repacking for shipment

CAUTION The chassis must be protected from static discharge and physical shock. Never remove any of the socketed parts except at a static-free workstation. Wear a grounded wrist strap when servicing.

Should it become necessary to return the Keithley Instruments KPXI System Chassis for repair, carefully pack the unit in its original packing carton or the equivalent, and follow these instructions:

- Call Keithley Instruments' repair department at 1-888-KEITHLEY (1-888-534-8453) for a Return Material Authorization (RMA) number.
- Let the repair department know the warranty status of the KPXI System Chassis.
- Write ATTENTION REPAIR DEPARTMENT and the RMA number on the shipping label.
- Complete and include the Service Form located at the back of this manual.

This page left blank intentionally.

In this section:

Topic	Page
Introduction	2-2
Power considerations	2-2
Installation	2-2
KPXI-SYS-18-460X2 , KPXI-SYS-8-400, and KPXI-SYS-14-500	2-2
KPXI-SYS-6-250 (6 slot chassis).....	2-3
System monitoring	2-3
Rack Mounting	2-4

Introduction

This section contains information about handling and installing Keithley Instruments' KPXI-SYS series 3U PXI Instrument Chassis:

- [Power considerations](#)
- [Installation](#)
- [System monitoring](#)

Power considerations

Before installing a module into the KPXI-SYS series chassis, make sure to calculate the total system power requirement (calculate the power budget). Check every DC power source including: +5V, +3.3V, +12V, and -12V supply rail. Please refer to the product data sheet for the maximum usable power for your specific chassis.

Installation

Refer to the applicable model number below for installation information.

KPXI-SYS-18-460X2 , KPXI-SYS-8-400, and KPXI-SYS-14-500

WARNING *The following mainframes have been evaluated for safety according to IEC-60950 as component assemblies: KPXI-SYS-18-460X2 , KPXI-SYS-8-400, and KPXI-SYS-14-500.*

To maintain the protection provided by these chassis, it is recommended that they be mounted inside a suitable rack or other enclosure according to the requirements of the end use.

Use the following steps as a guideline for installation of the chassis:

Step 1: Make sure the power switch is in the OFF position.

Step 2: Plug in the AC power cord in each power supply unit.

Step 3: Install the controller. Please check the ejector/injector handle is pushed down. Align the controller edge to the "RED" card guide, sliding in to the rear of the chassis. Push up on the ejector/injector handle to fully inject the card into the chassis. Secure the screws on the module's front panel. Connect the keyboard, mouse, and monitor to the controller with the ps2 Y-cable before booting system.

Step 4: Install peripheral modules if any.

Step 5: Press the power switch on the front panel to power on the chassis.

Step 6: Check the LED to make sure the power input is ready. There are four green LED indicators of 3.3V, 5V, +12V, and -12V. The four LED indicators will light with power on. The fans should become operational as well.

NOTE Refer to [Section 4](#) if the chassis does not power on.

KPXI-SYS-6-250 (6 slot chassis)

NOTE *It is not recommended to rack mount the 6 slot benchtop chassis (Model KPXI-SYS-6-250). No mounting brackets are included with this model.*

Use the following steps as a guideline for installation of the chassis:

Step 1: For desktop applications, please reserve sufficient space under the chassis for ventilation and make sure the surface the chassis is sitting on is flat and firm.

Step 2: Ensure the power switch is in the Standby (Off) position. There are two power switches on the KPXI-SYS-6-250 chassis. The switch in the rear is for turning ON or OFF the power cord input to the PSU (Power Supply Unit). The switch in the front is for turning ON or OFF the PSU DC power output to the PXI system. Note that the printed Keithley Instruments logo indicates the front panel of the chassis.

Step 3: Plug in the AC power cord.

Step 4: Make sure the CPU, RAM, and storage device are secured on the system controller module.

Step 5: Install the controller. Please check the ejector/injector handle is pushed down. Align the controller edge to the "RED" card guide, sliding in to the rear of the chassis. Push up on the ejector/injector handle to fully inject the module into the chassis. Secure the screws on the module's front panel. Connect the keyboard, mouse, and monitor to the controller with the ps2 Y-cable before booting system.

Step 6: Install peripheral modules, if necessary.

Step 7: Turn on the rear switch for inputting the AC power to the PSU. The amber LED will light.

Step 8: Turn on the front switch to power on the chassis. The amber LED will go off and the green LED will light.

Step 9: Check if the system power starts, the fans under the chassis should become operational as well.

NOTE *Refer to [Section 4](#) if the chassis does not power on.*

System monitoring

There are LEDs on the front panel of the 8, 14, and 18 slot chassis for system monitoring, including powers, temperature, and fans. Please refer to following for the detailed meaning of display status on LEDs.

Table 2-1
System Monitoring

LED	Description
Power LED (Voltage : 3.3V, 5V, +12V, -12V)	Color: Green ON while supplied
Temperature LED	Color: Amber ON for normal condition Flashes if exceeds temperature
Fan LED	Color: Green ON while normal fan speed Flashes if abnormal fan speed
Alarm LED	Color: Red ON while normal condition Flashes if alarm occurs

The Alarm Buzzer beeps continuously if any alarm occurs. When the Alarm Buzzer beeps, users can check the LED on the front panel to find out which kind of alarm occurs.

There is a black button labeled Alarm RST near by the Alarm LED on the front panel. When the Alarm LED flashes and the Alarm Buzzer continues beeping, you can push Alarm RST button to stop beeping.

NOTE Users can further refer to [Section 4](#) for Troubleshooting.

There is one Green LED on each power supply unit in the rear and the red button between the power supply units is power RST. When the alarm buzzer beeps and the power LED extinguishes, you can push power RST button to stop beeping and refer to [Section 4](#) to hot-swap the power supply unit.

Rack Mounting

NOTE It is not recommended to rack mount the 6 slot benchtop chassis (Model KPXI-SYS-6-250). No mounting brackets are included with this model.

The KPXI-SYS-8-400, KPXI-SYS-14-500, and the KPXI-18-450X2 are all suitable for rack mounting. The brackets needed for rack mounting are the same brackets used by the handles. To rack mount these chassis, use the following instructions:

1. Verify that you are installing the system into a standard 19" rack into a 4 U high space without any obstructions.
2. Remove the feet.
3. Remove the front handles from the side brackets. Do not remove the side brackets from the chassis (these brackets will be used for rack mounting, the handles pieces need to be removed to allow easy access to the holes used for rack mounting).
4. Guide the chassis into the rack and secure it using screws through both interior holes located on each side bracket.
 - Make sure that screws and fasteners used can support the weight of the chassis when fully loaded.
 - Make sure that screws are fastened tightly to the rack's vertical rails, either to fasteners or to holes that are threaded directly in the rails.

NOTE For the 18 slot chassis (Model KPXI-18-450X2), it is recommended to place the chassis on a shelf within the rack for further support.

In this section:

Topic	Page
Introduction	3-2
System controller slot	3-2
Local bus	3-2
KPXI-SYS-18-460X2	3-2
Star trigger slot	3-2
Peripheral slots	3-2
Trigger bus.....	3-2
System reference clock	3-3
KPXI-SYS-14-500	3-4
Star trigger slot	3-4
Peripheral slots	3-4
Trigger bus.....	3-4
System reference clock	3-4
KPXI-SYS-8-400	3-4
Star trigger slot	3-4
Peripheral slots	3-4
Trigger bus.....	3-4
System reference clock	3-5
KPXI-SYS-6-250	3-5
Star trigger slot	3-5
Peripheral slots	3-5
Trigger bus.....	3-6
System reference clock	3-6

Introduction

This section contains information on the Keithley Instruments KPXI-SYS series 3U PXI Instrument Chassis' backplanes. Features common to all Keithley Instruments KPXI-SYS series 3U PXI Instrument Chassis' backplanes are contained in this paragraph. For features that are specific to each model, refer to the following paragraphs:

- [KPXI-SYS-18-460X2, page 3-2](#)
- [KPXI-SYS-14-500, page 3-4](#)
- [KPXI-SYS-8-400, page 3-4](#)
- [KPXI-SYS-6-250, page 3-5](#)

System controller slot

The System Controller slot is Slot 1 of the chassis as defined by the PXI specification. It has three controller expansion slots, which are used for system controller modules that are wider than one slot. As defined in the PXI specification, these slots allow the controller to expand to the left to prevent the controller from using up peripheral slots.

Local bus

The local bus of the PXI backplane is daisy-chained, connecting each peripheral slot with adjacent peripheral slots (one to the left and one to the right). Each local bus is 13 lines wide and can pass analog signals between modules or provide a high-speed side-band communication path that does not affect the PXI bandwidth.

In accordance with the PXI specification, the local bus connections between all slots except slots 1 and 2.

KPXI-SYS-18-460X2

Star trigger slot

The Star Trigger (ST) slot is Slot 2. This slot has a dedicated trigger line between itself and slots 3-15 which is intended for modules with ST functionality that can provide individual triggers to the peripherals.

Peripheral slots

There are 17 peripheral slots including the Star Trigger controller slot.

Trigger bus

KPXI-SYS-18-460X2 has three PXI separate trigger bus segments. The PXI trigger bus is divided into three separate trigger buses at these locations. The trigger bus divisions represented by vertical bars on the front of the chassis. You can use triggers to synchronize the operation of several different PXI peripheral modules, or use one module to control carefully timed sequences of operations performed on other modules in the system. Modules can pass triggers to one another through the trigger bus, allowing precisely timed responses to asynchronous external events the system is monitoring or controlling.

Figure 3-1
KPXI-SYS-18-460X2 PXI Local Bus and Star Trigger Routing

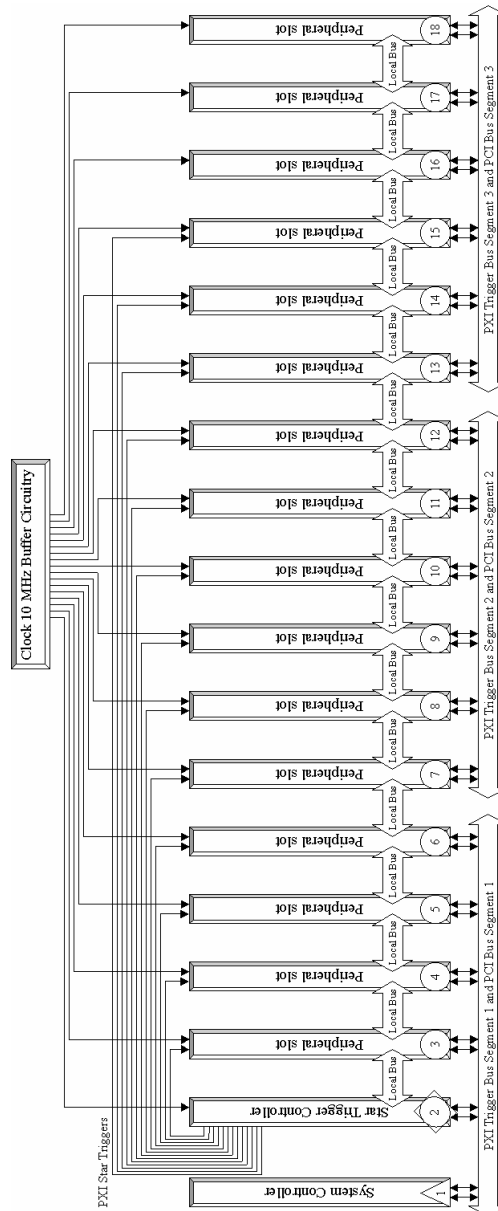

System reference clock

Model KPXI-SYS-18-460X2 supplies the PXI 10MHz system clock signal (PXI_CLK10) independently to every peripheral slot. An independent buffer (having a source impedance matched to the backplane and a skew of less than 1ns between slots) drives the clock signal to each peripheral slot. Users can use this common reference clock signal to synchronize multiple modules in a measurement or control system.

KPXI-SYS-14-500

Star trigger slot

The Star Trigger (ST) slot is Slot 2. This slot has a dedicated trigger line between itself and slots 3-11 which is intended for modules with ST functionality that can provide individual triggers to the peripherals.

Peripheral slots

There are 13 peripheral slots including the Star Trigger controller slot.

Trigger bus

Model KPXI-SYS-14-500 has a PXI trigger bus. Users can use triggers to synchronize the operation of several different PXI peripheral modules, or use one module to control carefully timed sequences of operations performed on other modules in the system. Modules can pass triggers to one another through trigger bus, allowing precisely timed responses to asynchronous external events the system is monitoring or controlling.

System reference clock

The Model KPXI-SYS-14-500 supplies the PXI 10MHz system clock signal (PXI_CLK10) independently to every peripheral slot. An independent buffer (having a source impedance matched to the backplane and a skew of less than 1ns between slots) drives the clock signal to each peripheral slot. Users can use this common reference clock signal to synchronize multiple modules in a measurement or control system.

KPXI-SYS-8-400

Star trigger slot

The Star Trigger (ST) slot is Slot 2. This slot has a dedicated trigger line between itself and slots 3-8 is intended for modules with ST functionality that can provide individual triggers to the peripherals.

Peripheral slots

There are 7 peripheral slots including the Star Trigger controller slot.

Trigger bus

Model KPXI-SYS-8-400 has a PXI trigger bus. Users can use triggers to synchronize the operation of several different PXI peripheral modules, or use one module to control carefully timed sequences of operations performed on other modules in the system. Modules can pass triggers to one another through trigger bus, allowing precisely timed responses to asynchronous external events the system is monitoring or controlling.

Figure 3-2
KPXI-SYS-8-400 PXI Local Bus and Star Trigger Routing

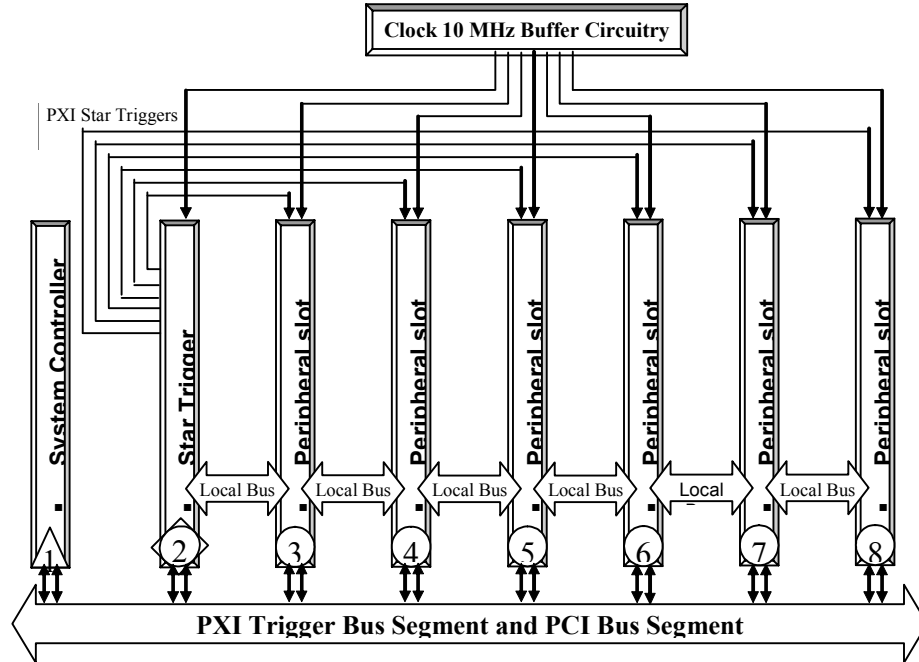

System reference clock

The Model KPXI-SYS-8-400 supplies the PXI 10MHz system clock signal (PXI_CLK10) independently to every peripheral slot. An independent buffer (having a source impedance matched to the backplane and a skew of less than 1ns between slots) drives the clock signal to each peripheral slot. Users can use this common reference clock signal to synchronize multiple modules in a measurement or control system.

KPXI-SYS-6-250

Star trigger slot

The Star Trigger (ST) slot is spotted at Slot 2. This slot has a dedicated trigger line, linking itself through Slot 3, 4, 5, and 6. It is intended for modules with ST functionality that can provide individual triggers to synchronize or trigger the peripherals easily.

Peripheral slots

There are 5 peripheral slots shown in the following diagram, inclusive of the Star Trigger controller slot.

Figure 3-3
 KPXI-SYS-6-250 PXI local bus and star trigger routing

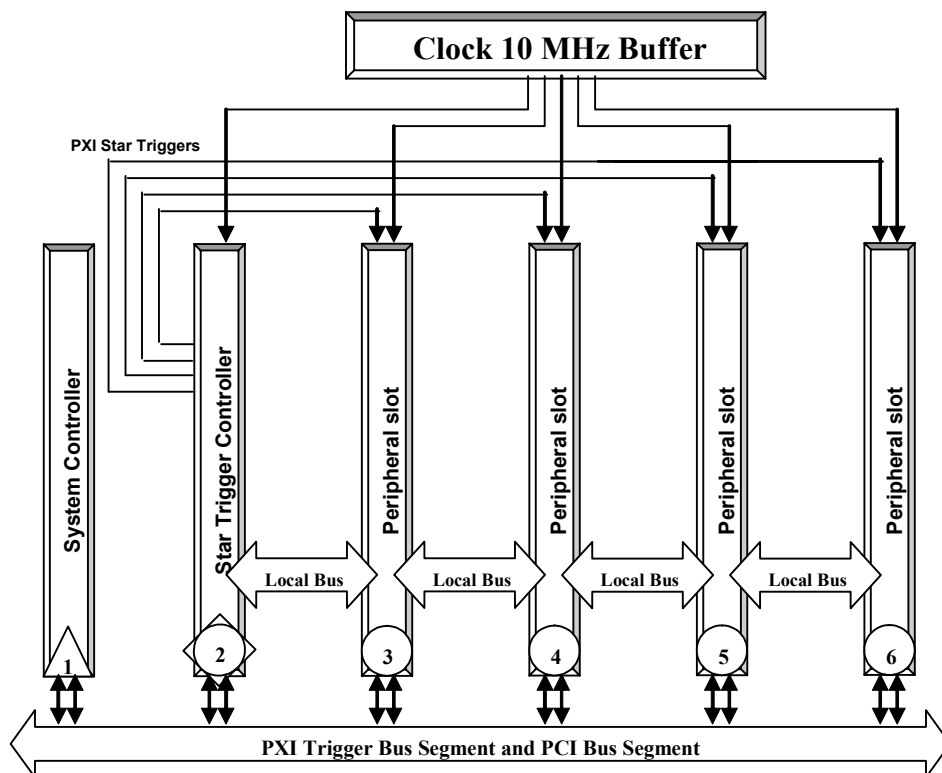

Trigger bus

KPXI-SYS-6-250 implements the dedicated PXI trigger bus with 8 lines. Users can use these trigger lines to synchronize the operation of several different PXI peripheral modules, or use one module to control carefully timed sequences of operations performed on other modules in the system. Modules can pass triggers to one another through trigger bus, allowing precisely timed responses to asynchronous external events the system is monitoring or controlling.

System reference clock

KPXI-SYS-6-250 supplies the PXI 10MHz system clock signal (PXI_CLK10) independently to every peripheral slot. An independent buffer (having a source impedance matched to the backplane and a skew of less than 1 ns between slots) drives the clock signal to each peripheral slot. Users can use this common reference clock signal to exactly synchronize multiple modules in a measurement or control system.

Troubleshooting and Maintenance

In this section:

Topic	Page
Introduction	4-2
Troubleshooting and maintenance	4-2
Temperature detection.....	4-2
Fan hot-swap replacement.....	4-2
Power supply unit hot-swap replacement.....	4-2

Introduction

This section contains troubleshooting and maintenance information on Keithley Instruments KPXI-SYS series 3U PXI Instrument Chassis.

Troubleshooting and maintenance

Refer to [Table 4-1](#) to troubleshoot the chassis. The table lists possible causes for power failure and recommends ways to correct the problem.

Table 4-1

Troubleshooting power failure

Possible Cause	What to Do
Chassis not connected to power source.	Make sure that the KPXI-SYS-18-460X2 is connected to a live electrical outlet. Try operating another piece of equipment from this outlet.
Power switch is not switched on.	Make sure that the power switch is set to the ON position.
The Alarm Buzzer is beeping	Push Alarm RST button to stop beeping and refer to Section 2 to find out which alarm occurs. Temperature LED flashes: Cool down the KPXI-SYS-18-460X2 system under 50°C Fan LED flashes: Check to see if anything is blocking the fan from spinning. If not, replace the fan. KPXI-SYS-14-500 and KPXI-SYS-18-460X2, and KPXI-SYS-8-400, see Fan hot-swap replacement
Power supply has failed	Model KPXI-SYS-18-460X2: Replace the power supply — see Power supply unit hot-swap replacement Other models: Contact Keithley Instruments for repair
The Power Buzzer is beeping	Check if both power supplies have power cord on it. If either one of the power supply failed, see Power supply has failed (above in this table).

Temperature detection

If the system overheats, an Amber Temp LED flashes and a buzzer beeps continuously. The over temperature alarm will activate when a temperature over 50°C is detected.

Fan hot-swap replacement

There is a LED for each fan for system monitoring. When any one of the fans is defective, the corresponding LED flashes and the alarm buzzer keeps beeping. Please refer to the following for the fan hot-swap replacement.

Fan Hot-Swap Replacement Procedure

Step 1: Press the Alarm RST button on the front panel to stop the beeping.

Step 2: Remove the fan's front panel cover.

Step 3: Pull out the defective fan.

Step 4: Replace with a new fan.

Step 5: Replace the fan's front panel cover.

Power supply unit hot-swap replacement

NOTE This procedure is for the Model KPXI-SYS-18-460X2 chassis only.

For the KPXI-SYS-18-460X2 chassis, there are four Green LED indicators for 3.3V, 5V, +12V, and -12V. There is also a Green LED for each power supply unit on the rear panel. The power unit is defective if the LED on the rear panel is extinguished or if the buzzer beeps continuously.

The red button between the power supply units is power RST. When alarm buzzer beeps caused by power defective, you can push power RST button to stop beeping.

PSU Hot-Swap Replacement Procedure

Step 1: Press the red button on the rear panel to stop the buzzer beeping.

Step 2: Locate the defective power by examining the indication of the individual LED on the rear panel.

Step 3: Unplug the power cord of defective power supply from AC inlet.

Step 4: Unscrew all mounting screws fixing the defective power supply unit.

Step 5: Pull out the defective unit.

Step 6: Replace with a new power supply unit. Contact Keithley Instruments for a replacement power supply unit.

Step 7: Screw all mounting screws to fix the new power supply unit.

Step 8: Plug in the power cord.

This page left blank intentionally.

Model No. _____ **Serial No.** _____ **Date** _____

Name and Telephone No. _____

Company _____

List all control settings, describe problem and check boxes that apply to problem. _____

Intermittent Analog output follows display Particular range or function bad; specify

IEEE failure Obvious problem on power-up Batteries and fuses are OK

Front panel operational All ranges or functions are bad Checked all cables

Display or output (check one)

Drifts Unable to zero Unstable

Overload Will not read applied input

Calibration only Certificate of calibration required Data required

(attach any additional sheets as necessary)

Show a block diagram of your measurement including all instruments connected (whether power is turned on or not).
Also, describe signal source.

Where is the measurement being performed? (factory, controlled laboratory, out-of-doors, etc.) _____

What power line voltage is used? _____ Ambient temperature? _____ °F

Relative humidity? _____ Other? _____

Any additional information. (If special modifications have been made by the user, please describe.)

Be sure to include your name and telephone number on this service form.

Specifications are subject to change without notice.
All Keithley trademarks and trade names are the property of Keithley Instruments, Inc.
All other trademarks and trade names are the property of their respective companies.



A G R E A T E R M E A S U R E O F C O N F I D E N C E

Keithley Instruments, Inc.

Corporate Headquarters • 28775 Aurora Road • Cleveland, Ohio 44139 • 440-248-0400 • Fax: 440-248-6168 • 1-888-KEITHLEY • www.keithley.com