

Instruction Manual

Tektronix

**P6015A
1000X High Voltage Probe**

070-8223-06



Warning

The servicing instructions are for use by qualified personnel only. To avoid personal injury, do not perform any servicing unless you are qualified to do so. Refer to all safety summaries prior to performing service.

www.tek.com

Copyright © 2024, Tektronix. 2024 All rights reserved. Licensed software products are owned by Tektronix or its subsidiaries or suppliers, and are protected by national copyright laws and international treaty provisions. Tektronix products are covered by U.S. and foreign patents, issued and pending. Information in this publication supersedes that in all previously published material. Specifications and price change privileges reserved. All other trade names referenced are the service marks, trademarks, or registered trademarks of their respective companies.

TEKTRONIX and TEK are registered trademarks of Tektronix, Inc.

Tektronix, Inc.
14200 SW Karl Braun Drive
P.O. Box 500
Beaverton, OR 97077
USA

For product information, sales, service, and technical support visit [tek.com](https://www.tek.com) to find contacts in your area. For warranty information visit [tek.com/warranty](https://www.tek.com/warranty).



Table of Contents

General Safety Summary	v
Service Safety Summary	vii
Environmental Considerations	viii

User Information

Overview	1-1
Readout Option	1-3
Standard Accessories	1-4
Options	1-4
Setup	1-5
In Detail	1-7
General Guidelines	1-7
Maximum Input Voltage	1-10
Probe Grounding	1-13
Probe Compensation	1-15
Caring for the Probe	1-20
Other Considerations	1-21
Problems Encountered Using the Probe	1-21
Specifications	1-23
Warranted Characteristics	1-23
Typical and Nominal Characteristics	1-27

Service Information

Performance Verification	2-1
Adjustments	2-3
Test Equipment Required	2-3
Preparation	2-3
Long-Form Procedure	2-5
Maintenance.....	2-11
Preventive Maintenance	2-11
Troubleshooting and Repair	2-12
Mechanical Disassembly and Assembly	2-13
Replaceable Parts	2-17
Parts Ordering Information	2-17
Using the Replaceable Parts List	2-18

Index

List of Figures

Figure 1-1: The P6015A High-Voltage Probe	1-2
Figure 1-2: Compensation Box with Readout Option	1-3
Figure 1-3: Assembling the P6015A	1-5
Figure 1-4: Maximum Input Voltage Derating and RF burn risk area	1-12
Figure 1-5: Peak Pulse Derating	1-13
Figure 1-6: Zones Affected by Compensation Adjustments	1-18
Figure 1-7: Humidity Derating Chart	1-26
Figure 1-8: Typical Input Impedance and Phase	1-26
Figure 2-1: Access to Long-Form Adjustments	2-5
Figure 2-2: Adjustment Locations	2-7
Figure 2-3: Periods Affected by Compensation Adjustments	2-8
Figure 2-4: Removal and Replacement of Probe Head	2-14
Figure 2-5: P6015A Exploded View	2-19

List of Tables

Table 1 -1: Maximum Input Voltage ^{1,2,3}	1 -10
Table 1 -2: Test Equipment Required for Short-Form Adjustment	1 -16
Table 1 -3: Warranted Electrical Characteristics	1 -24
Table 1 -4: Warranted Environmental Characteristics	1 -25
Table 1 -5: Typical Electrical Characteristics	1 -27
Table 1 -6: Nominal Mechanical Characteristics	1 -28
Table 2 -1: Test Equipment Required for Long-Form Adjustment	2 -4

General Safety Summary

Review the following safety precautions to avoid injury and prevent damage to this product or any products connected to it.

To avoid potential hazards, use this product only as specified.

Only qualified personnel should perform service procedures.

To Avoid Fire or Personal Injury

Connect and Disconnect Properly. Do not connect or disconnect probes or test leads while they are connected to a voltage source.

Connect and Disconnect Properly. Connect the probe output to the measurement instrument before connecting the probe to the circuit under test. Connect the probe reference lead to the circuit under test before connecting the probe input. Disconnect the probe input and the probe reference lead from the circuit under test before disconnecting the probe from the measurement instrument.

Ground the Product. This product is indirectly grounded through the grounding conductor of the mainframe power cord. To avoid electric shock, the grounding conductor must be connected to earth ground. Before making connections to the input or output terminals of the product, ensure that the product is properly grounded.

WARNING – RISK OF ELECTRIC SHOCK. Only a properly grounded oscilloscope may be used with this probe. Operators must ensure that the oscilloscope is grounded to protective earthing before using the P6015A probe.

Observe All Terminal Ratings. To avoid fire or shock hazard, observe all ratings and markings on the product. Consult the product manual for further ratings information before making connections to the product.

The inputs are not rated for connection to mains or Category II, III, or IV circuits.

Connect the probe reference lead to earth ground only.

Do not apply a potential to any terminal, including the common terminal, that exceeds the maximum rating of that terminal.

Do Not Operate Without Covers. Do not operate this product with covers or panels removed.

Do Not Operate With Suspected Failures. If you suspect there is damage to this product, have it inspected by qualified service personnel.

Avoid Exposed Circuitry. Do not touch exposed connections and components when power is present.

Do not operate with suspected failures. Before use, inspect voltage probes, test leads, and accessories for mechanical damage and replace when damaged. Do not use probes or test leads if they are damaged, if there is exposed metal, or if a wear indicator shows.

Do Not Operate in Wet/Damp Conditions.

Do Not Operate in an Explosive Atmosphere.

Keep Product Surfaces Clean and Dry.

These terms may appear in this manual:



WARNING. *To avoid electric shock, keep the probe wire as far from the tip and high voltage circuits as possible. The probe wire voltage rating is less than the probe tip voltage rating. Therefore, the probe wire may not provide adequate protection.*

Terms in this Manual

These terms may appear in this manual:



WARNING. *Warning statements identify conditions or practices that could result in injury or loss of life.*



CAUTION. *Caution statements identify conditions or practices that could result in damage to this product or other property.*

Symbols and Terms on the Product

These terms may appear on the product:

- DANGER indicates an injury hazard immediately accessible as you read the marking.
- WARNING indicates an injury hazard not immediately accessible as you read the marking.
- CAUTION indicates a hazard to property including the product.

The following symbol(s) may appear on the product:



Service Safety Summary

Only qualified personnel should perform service procedures. Read this *Service Safety Summary* and the *General Safety Summary* before performing any service procedures.

Do Not Service Alone. Do not perform internal service or adjustments of this product unless another person capable of rendering first aid and resuscitation is present.

Use Care When Servicing with Power On. Dangerous voltages or currents may exist in this product. Disconnect power, remove battery (if applicable), and disconnect test leads before removing protective panels, soldering, or replacing components.

To avoid electric shock, do not touch exposed connections.

Environmental Considerations

This section provides information about the environmental impact of the product.

Product End-of-Life Handling

Observe the following guidelines when recycling an instrument or component:

Equipment Recycling. Production of this equipment required the extraction and use of natural resources. The equipment may contain substances that could be harmful to the environment or human health if improperly handled at the product's end of life. In order to avoid release of such substances into the environment and to reduce the use of natural resources, we encourage you to recycle this product in an appropriate system that will ensure that most of the materials are reused or recycled appropriately.



The symbol shown to the left indicates that this product complies with the European Union's requirements according to Directive 2002/96/EC on waste electrical and electronic equipment (WEEE). For information about recycling options, check the Support/Service section of the Tektronix Web site (www.tektronix.com).

Restriction of Hazardous Substances

This product has been classified as Monitoring and Control equipment, and is outside the scope of the 2002/95/EC RoHS Directive. This product is known to contain lead, cadmium, mercury, and hexavalent chromium.

Overview

The P6015A is a ground-referenced 100 M Ω , 3.0 pF high voltage probe with 1000X attenuation. It adds high-voltage measurement capability to oscilloscopes and other measurement devices having an input resistance of 1 M Ω and an input capacitance of 7 pF to 49 pF.



WARNING. *Due to the inherent hazards associated with taking high-voltage measurements, this product is intended for use by qualified personnel who have had the training to take these types of measurements.*

Read and follow the precautions specified in this manual.

The P6015A consists of two major assemblies: the probe body and the compensation box (see Figure 1 -1).

- The probe body houses the probe tip, head, and ground lead. The probe body is made of high-impact thermoplastic that provides mechanical protection for the probe's internal components and electrical protection for the user.
- The compensation box connects a ground-referenced oscilloscope or other grounded measuring device and has a cable that attaches to the probe body. The compensation box contains an adjustment network to optimize frequency response up to 75 MHz.



WARNING. *To avoid shock, keep hands and fingers behind the guard ring on the probe when the probe is connected to voltages.*

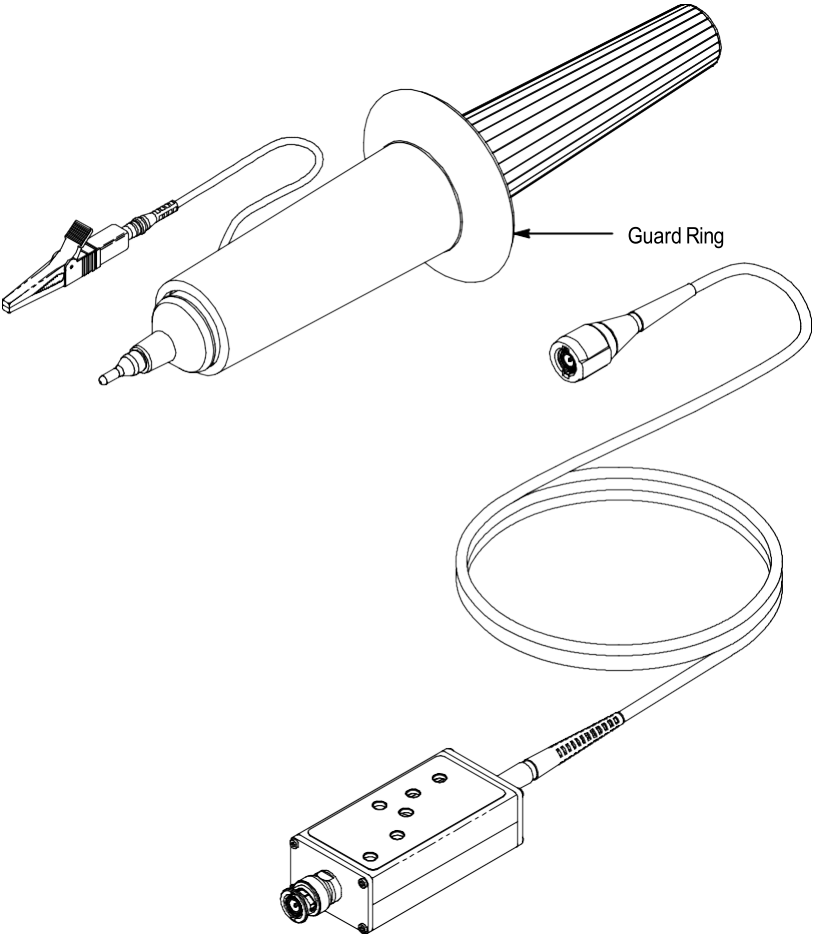

Figure 1- 1: The P6015A High-Voltage Probe

Readout Option

P6015A compensation boxes that feature the readout option have a pin protruding from the BNC connector (Figure 1-2). Some models of Tektronix oscilloscopes (11000 Series and Digital Storage Oscilloscopes) read the code presented by this pin and automatically scale the P6015A measurements by a factor of 1000 to compensate for attenuation.

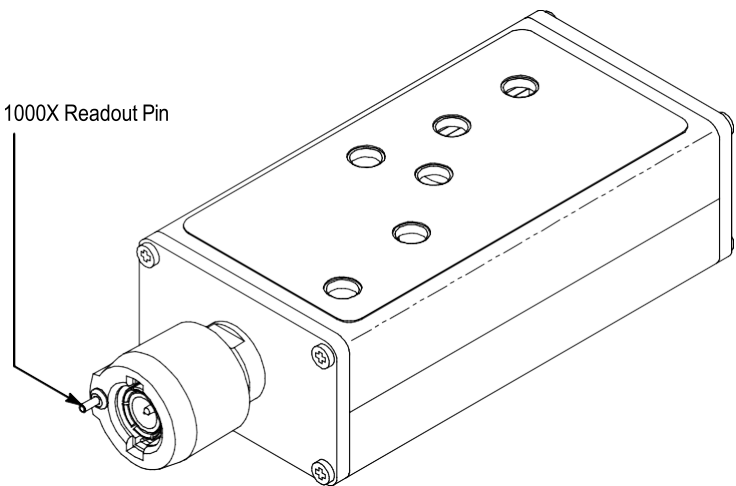

Figure 1-2: Compensation Box with Readout Option

Standard Accessories

The P6015A comes with the following accessories:

- ground lead and plug-on clip
- hook-shaped probe tip
- banana-plug probe tip
- carrying case
- instruction manual

Options

The standard P6015A has a 10-ft cable without 1000X readout. The following options are available:

- Option 1R: 10-ft cable and 1000X readout

Setup

This section tells you how to assemble the P6015A modules as you unpack them from the carrying case. Refer to Figure 1-3 while following these steps:

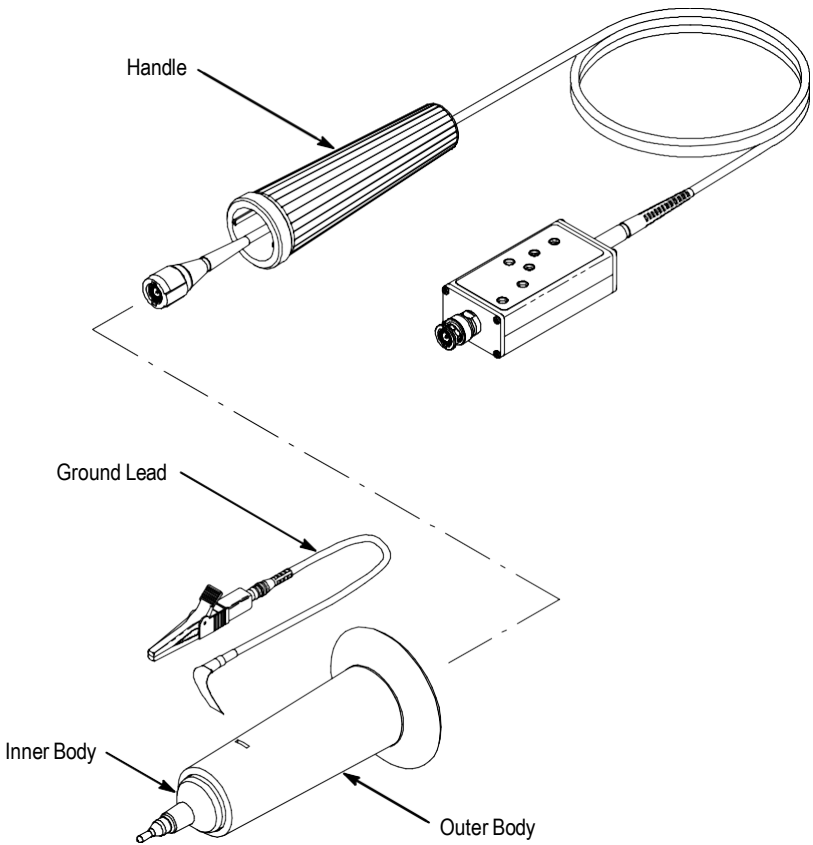

Figure 1-3: Assembling the P6015A

1. Insert the end of the cable into the narrow end of the handle and feed the BNC out the other side.
2. Connect the cable to the BNC on the probe head.
3. Screw the handle into the outer body.
4. Plug the crocodile ground clip onto the ground lead if it is not already attached.
5. Read *In Detail*, beginning on page 1-7, before attempting to make probe measurements.

In Detail

Before you make any oscilloscope measurement, observe all safety precautions described in the user and service manuals for the equipment you are working on. Some general rules about servicing electrical equipment are worth repeating here.

- Observe the safety instruction symbols for the equipment you are working on.
- Consult the service manual for the equipment you are working on.
- Don't operate or service an electrical device in an explosive atmosphere.
- Avoid personal injury by never touching exposed connections or components in the circuit-under-test when the power is on.

General Guidelines

To make high-voltage measurements with the P6015A probe, first connect the BNC connector of the probe compensation box to the measurement device (oscilloscope, digital voltmeter, etc.). Next, connect the ground clip of the probe to a ground point of the circuit under test. After you have made these connections, you are ready to connect the probe tip to a high-voltage point.

Handheld Operation

The P6015A probe is designed for handheld use when used with the straight or hook shaped probe tips. When using the straight tip, the probe should be held by the plastic handle, behind the probe guard ring, and the tip should be held against the high voltage test point. The hook shaped tip can be used to hang the probe from a bus bar, wire loop, or other test point.



WARNING. *When measuring high voltages, avoid contact with or close proximity to any electrically conductive surface with your body. Keep hands and fingers behind the guard ring on the probe.*



WARNING. *Make sure that the circuit is deenergized, and that any stored energy is completely discharged before probe installation or removal. Failure to discharge the circuit may cause serious or fatal shock.*



CAUTION. *When mounting the probe into test fixtures, the duration ratings in Table 1-1 on page 1-10 must be followed. Only clamp onto the metal shield section of the probe when mounting the probe. Intense electric fields are present when the probe is connected to a high voltage source. Attaching a conductive or dielectric mount beyond the metal shield may result in poor response characteristics or probe damage.*

Readout

If your P6015A has the readout option and is being used with an instrument having readout capability, the display automatically corrects for the probe attenuation factor. (Refer to *Overview* on page 1-1 for information about the P6015A readout option.)

If your instrument does not recognize the readout correction, multiply your voltage measurements by 1000.

NOTE. *Some oscilloscopes may misinterpret the 1000X attenuation code. Contact your local Tektronix representative if you have questions.*

Probe Placement



CAUTION. *Probe placement can be critical in some applications.*

To minimize Device-Under-Test circuit loading, the P6015A input resistance is very large and input capacitance is very small. Small changes in capacitance near the input resistor will affect the accuracy of the measurement. These changes can result from placing the probe tip near conductive surfaces. Changes in the input capacitance will change the probe compensation, causing the leading edge of pulses to overshoot or undershoot the true pulse amplitude. The time constant will not be visible on shorter pulses where the entire top of the measured waveform will appear to be the wrong amplitude. Surfaces connected to the input signal will peak the response, resulting in overshoot, while those that are static or grounded will dampen the response, resulting in an undershoot.

To minimize the chance of changing the probe compensation, do not allow the conductor, to which the probe is attached, to pass along the side of the probe body. Keep the probe perpendicular to the attached conductor or at the end of a dedicated test lead. If the test configuration does not allow this, minimize the error by readjusting the probe compensation by connecting the probe to the calibration generator that closely duplicates the physical configuration used in the actual measurement.

Maximum Input Voltage

Table 1 -1 and the following paragraphs indicate conditions where the maximum input of the P6015A is reduced.

Table 1-1: Maximum Input Voltage^{1,2,3}

Max. On Time	≥30 Minutes	<30 Minutes	≥15 Minutes	<15 Minutes
Temperature Range °C	0 to 35	0 to 35	36 to 50	36 to 50
V _{RMS} ^{4,5,6}	14 kV	15 kV	14 kV	15 kV
V _{DC}	14 kV	15 kV	14 kV	15 kV
V _(DC+PK AC)	28 kV	40 kV	28 kV	40 kV
V _(Peak Pulse) 10% Duty Cycle	28 kV	40 kV	28 kV	40 kV
V _(Peak Pulse) 20% Duty Cycle	25 kV	36 kV	25 kV	36 kV
V _(Peak Pulse) 30% Duty Cycle	23 kV	33 kV	23 kV	33 kV
V _(Peak Pulse) 50% Duty Cycle	18 kV	28 kV	18 kV	28 kV

- 1 Voltage readings are based on a thermal time constant of 30 minutes with no more than a 60° internal temperature rise. Internal component heating is not to exceed 4 W at less than 30 minutes or 2 W at greater than 30 minutes. If the 4 W limit is exceeded in less than 30 minutes, then a cool-down period of up to 2.5 hours is required for any further probe use.
- 2 Voltage ratings are based on a thermal time constant of 30 minutes.
- 3 The maximum pulse duration must not exceed 100 ms (see the derating chart in Figure 1-5 on page 1- 13).
- 4 $RMS = \text{Root Mean Square} = r_{ms} = \text{The square root of the average of the sum of the squares of the instantaneous voltage in one cycle} = \sqrt{\sum (f x_i)^2 / n}$
- 5 $RMS = (1/2 \text{ Peak V @ } 25\% \text{ DF}) = (500 V_{pk} \div 2) = 250 V_{rms} \text{ (DF = Duty Factor)}$
- 6 $RMS = [(V_{pk})^2 (DF)]^{1/2}$

The maximum input voltage of 15 kV (DC + peak AC) is derated at frequencies above 460 kHz (See Figure 1 -4 on page 1 -12).

The maximum peak pulse of 40 kV (which must never exceed 15 kV_{rms}) is derated under the following conditions:

- Duty cycles greater than 10% or durations longer than 100 ms (Figure 1 -5). Duty cycle is the ratio of pulse width to signal period, expressed as a percentage.
- Altitudes higher than 8000 feet (2440 m). See tables 1 -3 and 1-4.
- Relative humidity greater than 80% at 25° C, 70% at 35° C, or 30% at 50° C. See Tables 1 -3 and 1 -4.
- For voltages above Long Duration Line of Figure 1 -5 on page 1 -13, the time exposure is limited per Table 1 -1 in any 2.5 hour period.



CAUTION. *The ground lead is rated at 1 kV maximum. Make sure the ground lead does not contact the probe tip or a high voltage point on the circuit under test.*

NOTE. *This probe is designed to take voltage measurements between 1.5 kV and 15 kV (DC + peak AC) and impulses up to 40 kV peak. For taking voltage measurements below 1.5 kV, Tektronix makes a variety of probes specifically for these applications.*

NOTE. *The Deratings in figure 1-4 are based off thermal analysis and not safety analysis.*



WARNING. While measuring high frequency common mode signals, there is a risk of RF burns. Refer to the following derating curve to identify the danger areas. Measuring common mode signals within the gray shaded area can result in RF burns within 1 m (40 in.) of the sensor head and earth ground.

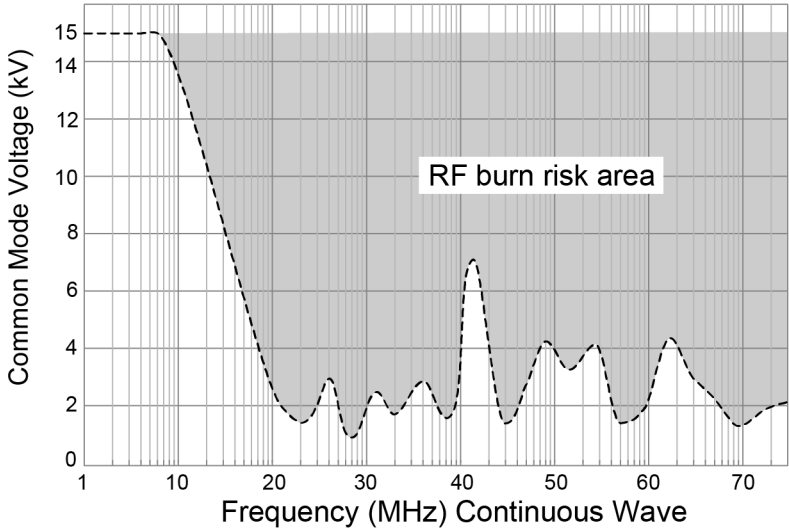

Figure 1- 4: Maximum Input Voltage Derating and RF burn risk area

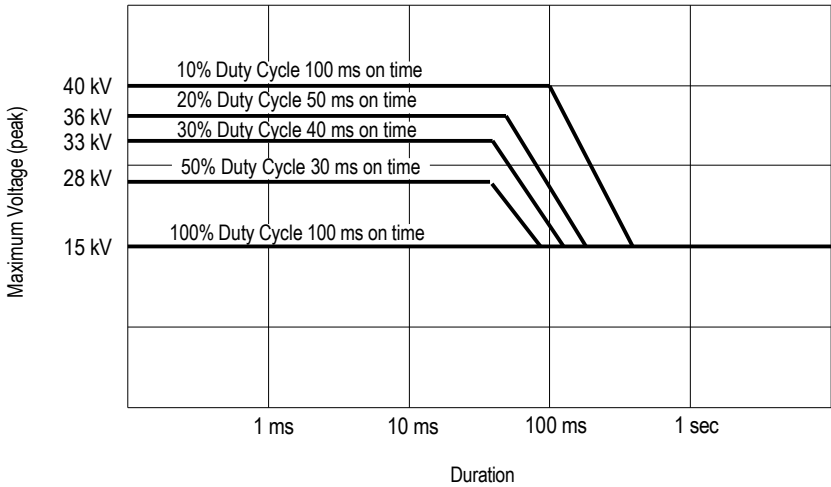

Figure 1-5: Peak Pulse Derating

Probe Grounding

When making any measurement, use the probe ground connector to form the basic two-terminal connection to the device under test.



CAUTION. *The ground lead is rated at 1 kV maximum. Make sure the ground lead does not contact the probe tip or a high-voltage point on the circuit under test.*

NOTE. *If you want to check the presence or absence of signals from low-frequency equipment, and if the equipment is line-powered and plugged into the same outlet system as the oscilloscope, then the common three-wire ground system provides the signal ground return. However, this indirect route adds inductance in the signal path, which can produce ringing and noise on the displayed signal, and therefore is not recommended.*

Don't assume that the ground in the circuit under test is the same as the oscilloscope ground. Check the circuit ground by first attaching the ground lead of the probe to a known earth ground, then touch the probe tip to the point you think is ground. If there is any voltage differential, then the point that the tip is connected to is not a valid ground point. (Due to the 1000X attenuation of the P6015A, you may have to increase the sensitivity of the oscilloscope in order to see small voltage differentials.) Perform this check before you attach the ground lead of the probe to a ground point on the circuit under test. The oscilloscope ground should always be earth ground as long as you are using the proper power cord and plug.

Ground Lead Inductance

When making any kind of absolute measurement, such as amplitude, rise time or time delay measurements, use the shortest grounding path possible.

NOTE. *Even with the shortest ground lead, probe capacitance and ground lead inductance form a series-resonant circuit that has the potential to ring. Such ringing oscillations depend on the high-frequency components of the transient you are measuring and will distort the true waveform. The ability to see the ringing depends on the oscilloscope bandwidth. The amount of displayed ringing can be reduced by using the bandwidth limit function of the oscilloscope.*

If you are going to be probing many different points in the same circuit having signal frequencies less than 1 MHz, you can run a ground wire from the circuit ground to the oscilloscope ground terminal (if one is provided). Such a ground connection alleviates the need to continually reconnect the probe ground lead.

Probe Compensation

Short-Form Compensation Procedure

The short-form compensation procedure given in this section adjusts for use of the probe on a different oscilloscope input or at a drastically different temperature than that at which it was calibrated (a difference greater than $\pm 15^{\circ}\text{C}$). The adjustments necessary under these conditions are accessible through holes in the top cover of the compensation box.

The long-form procedure is included in the *Adjustments* section of Chapter 2. Use the long-form procedure when a part of the probe is replaced, or when the probe has gone for a long time without recompensation and cannot be compensated using the short-form procedure. Should this become necessary, refer compensation to a qualified service person.

The short-form procedure consists of three parts, which should be performed in the order listed:

1. Adjust DC attenuation
2. Adjust low-frequency compensation
3. Adjust transient response

Test Equipment Required. The test equipment listed in Table 1 -2, or its equivalent, is required for completion of this procedure. If equipment is substituted, control settings or test equipment setup may need to be altered. Any needed maintenance should be performed before proceeding with compensation. Troubles that become apparent during compensation should be corrected immediately.

Table 1-2: Test Equipment Required for Short-Form Adjustment

Item	Minimum Requirements	Recommended Example	Application
Oscilloscope	Input Impedance: 1 M Ω Sensitivity: 1 mV/div Bandwidth: \geq 100 MHz	Tektronix 11402A with 11A32 plug-in, or Tektronix TDS 460	All adjustments
Calibration Generator	Rise time: \leq 10 ns Repetition rate: 1 MHz Amplitude: \geq 50 V	Tektronix PG 506A ^{1,2}	All adjustments
BNC Male-to-GR Adapter		Tektronix part number 017-0064-00	All adjustments
BNC 50 Ω Termination		Tektronix part number 011-0049-01	Transient response adjustment

¹ Oscilloscopes with less than 1mV/div sensitivity can be used while making most adjustments. However, because of the 1000X probe attenuation, the system will not display sufficient deflection for optimum adjustment of transient response unless a calibration generator having higher amplitude output is substituted.

² Requires TM 500 or TM 5000 Series Power Module or equivalent.

DC Attenuation

1. Connect the P6015A compensation box to the oscilloscope.
2. Connect a BNC male-to-GR adapter to the calibration generator amplitude output. Connect the P6015A ground lead clip to the outer fin of the GR connector.



WARNING. *The calibration generator produces dangerous voltages during these procedures. To avoid electrical shock, be careful not to touch the GR center conductor or exposed portions of the probe tip while the generator is on.*

3. Insert the tip of the P6015A into the GR center conductor.
4. Set the calibration generator to standard amplitude output of 50 Volts. This setting on a PG 506A produces a 1 kHz square wave.
5. Set the oscilloscope time base to display 500 $\mu\text{s}/\text{div}$, and set the vertical deflection to 10 mV/div (10 V/div when using the readout option).
6. Center the waveform on the screen.
7. Adjust **DC ATTEN** (R9) for five divisions. Use the trailing portion of the square wave if the leading corner is not flat.

Low-Frequency Compensation

1. Set the calibration generator to high amplitude output, and set the period to 1 ms. Set the pulse amplitude to display five divisions.
2. Set the oscilloscope time base to display 200 $\mu\text{s}/\text{div}$.
3. Center the waveform on the screen.
4. Adjust **LF COMP** (C5) so that the leading corner of the square wave is level with the trailing corner.
5. Adjust **MID 1** (C1) to flatten the area 200 μs from the leading corner. Refer to Figure 1-6 to determine the zones affected by this and the following adjustments.

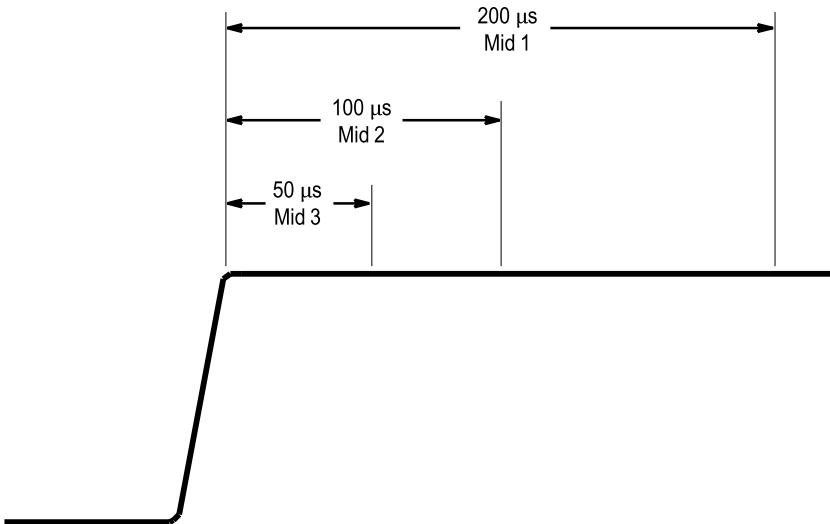

Figure 1-6: Zones Affected by Compensation Adjustments

6. Adjust **MID 2** (C2) to flatten the area 100 μs from the leading corner.
7. Adjust **MID 3** (C4) to flatten the area 50 μs from the leading corner.

Some interaction exists between the **LF COMP**, **MID 1**, **MID 2**, and **MID 3** adjustments. Steps 4 through 7 may have to be repeated several times to achieve optimum flatness of the square wave.

Transient Response

1. Set the calibration generator pulse amplitude to minimum.
2. Set the calibration generator output to a square wave with rise time ≤ 10 ns. If you are using a PG 506A, do this by inserting a 50 Ω termination between the amplitude output and the BNC male-to-GR adapter.
3. Set the oscilloscope time base to display 100 ns/div. Set the oscilloscope vertical deflection to 1 mV/div (1 V/div when using the readout option).
4. Set the calibration generator period to 1 μs , and set the pulse amplitude to display five divisions.
5. Center the waveform on the screen.
6. Adjust **HF COMP** (R6) for overall flatness of the front corner.

Caring for the Probe

Follow these guidelines to prolong the life of your probe:

- Observe the time and temperature specifications for this product shown in the Maximum Input Voltage Chart on page 1 -4.
- Don't connect a probe ground lead to elevated ("hot") circuitry. The resultant damage is not covered by probe warranties.
- Don't measure voltages in excess of the probe's maximum voltage rating.
- Don't mount the probe into fixtures by its nonmetallic front end. Mount the probe only by its metallic shield portion.
- Don't attempt to remove the rubber cushioning ring from the inner body assembly of the probe head.
- Don't attempt to disassemble the inner body assembly.
- When you are not using the probe, place the probe and its accessories in the case provided.
- Don't use the probe to scrape through insulation, pry components, or to move components.
- When necessary, clean the probe with a damp cloth.

Other Considerations

Component heating caused by changes in ambient temperature or high voltage will cause a slight change in calibration accuracy.

With high-frequency signals, such as fast transients, ringing may occur which will distort the actual waveform. This ringing is due to resonance occurring between the capacitance of the probe and the ground lead inductance.

Problems Encountered Using the Probe

If you experience problems making measurements with the probe, consider the following remedies:

- Check low frequency compensation and adjust as necessary.
- If you have the probe connected to an oscilloscope, check the front panel controls of the oscilloscope to verify that the signal is displayed properly.
- Use a ground lead.
- Don't use ground leads that are too long (causing ringing).
- Because of probe characteristics, small differences in input capacitance between oscilloscopes and scope channels can affect the voltage measurement. The probe compensation should be checked each time the probe is connected to a different input channel or to a different oscilloscope.



Specifications

Warranted Characteristics

This section lists the various warranted characteristics that describe the P6015A High Voltage Probe. Included are warranted electrical and environmental characteristics.

Warranted characteristics are described in terms of quantifiable performance limits which are warranted.

The electrical characteristics listed in Table 1-3 apply under the following conditions:

- The probe and instrument with which it is used must have been calibrated at an ambient temperature of between +20 °C and +30 °C.
- The probe and instrument must be in an environment whose limits are described in Table 1-3.
- The probe and instrument must have had a warm-up period of at least 20 minutes before applying elevated voltages.

Table 1-3: Warranted Electrical Characteristics

Characteristic	Information	
Maximum input voltage DC + peak AC ¹	1.5 kV to 15 kV. See frequency derating curve in Figure 1 -4. (DC plus peak AC rating is limited to temperatures below 35° C.)	
Peak pulse	40 kV ^a (Never exceed 15 kV rms) Duty cycle derating - 100 ms maximum duration at 10% maximum duty cycle. See duration and duty cycle derating curve in Figure 1 -5. Altitude derating - Peak pulse derated linearly from 40 kV at 8000 feet (2440 m) to 30 kV at 15,000 feet (4570 m) altitude. Relative Humidity (RH) derating - Voltage derated with increasing temperature and relative humidity (see Figure 1 -7).	
Bandwidth (-3 dB)	Test conditions: Test oscilloscope bandwidth must be ≥ 100 MHz, $Z_{source} = 25 \Omega$	
10-ft cable	75 MHz	
Rise Time ² 10-ft cable	≤ 4.67 ns (calculated from bandwidth)	
DC attenuation	1000:1 $\pm 3\%$ (Excluding oscilloscope error)	Test conditions: Oscilloscope input resistance must be $1 M\Omega \pm 2\%$

1 Characteristic not checked in manual

2 T_r (ns) = .35/BW (MHz)

Table 1- 4: Warranted Environmental Characteristics

Characteristic	Information
Temperature	
Nonoperating	-55°C to +75°C (-67°F to +167°F)
Operating	
DC + peak AC	0°C to +35°C (+32°F to +95°F)
Peak Pulse	0°C to +50°C (+32°F to +122°F), Non-continuous operation (See Table 1-1 on page 1-10 and <i>Time Limitations</i> Specification below)
Humidity	
Nonoperating / Operating	95% relative humidity at +50 °C (+122 °F). See Figure 1 -7 for derating characteristics.
Maximum altitude	
Nonoperating	15,000 m (50,000 ft)
Operating	3,000 m (9,843 ft) Peak pulse voltage derated from 40 kV at 8000 feet (2440 m) to 30 kV at 15,000 feet (4570 m).
Vibration (random)	
Nonoperating	3.48 g rms from 5 to 500 Hz. Ten minutes on each axis.
Operating	2.66 g rms from 5 to 500 Hz. Ten minutes on each axis.
Shock (nonoperating)	500 g, half sine, 0.5 ms duration, 18 shocks total in three axis.
Time Limitations	
Less than 70% of Rated Input Voltage at 0-35°C	No time limit
Greater than 70% of Rated Input Voltage at 0-35°C	30 minutes maximum in any 2.5 hour period
35-50°C	15 minutes maximum in any 2.5 hour period

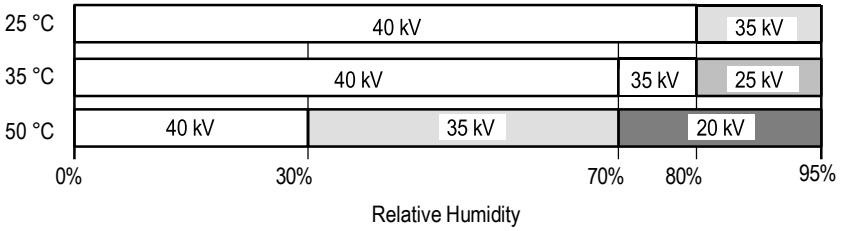

Figure 1-7: Humidity Derating Chart

NOTE. The Deratings are based off thermal analysis and not safety analysis.

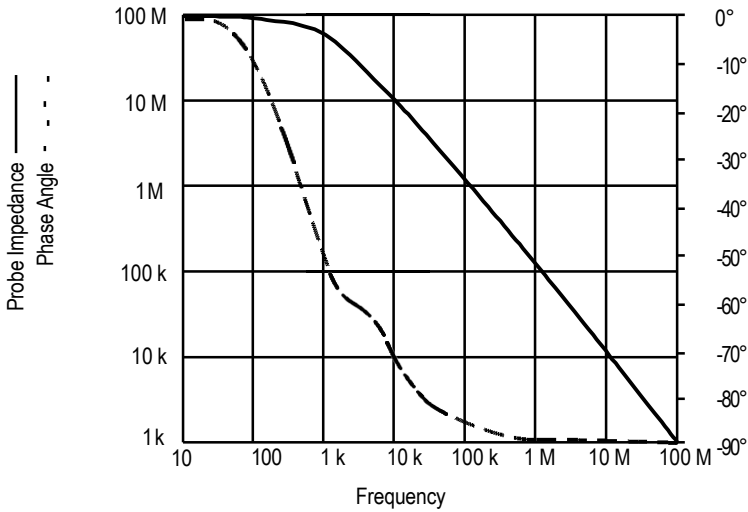

Figure 1-8: Typical Input Impedance and Phase

Typical and Nominal Characteristics

This section lists the various typical and nominal characteristics that describe the P6015A High Voltage Probe.

Nominal characteristics are determined by design and/or inspection. Nominal characteristics do not have tolerance limits.

Typical characteristics are described in terms of typical or average performance. Typical characteristics are not warranted.

Table 1-5: Typical Electrical Characteristics

Characteristic	Information
Input resistance	100 M Ω \pm 2%. See Figure 1-8 for typical input impedance curve.
Input capacitance	\leq 3 pF when probe is properly LF compensated. See Figure 1-8 for typical input impedance curve.
LF compensation range	7 pF to 49 pF
Aberrations	25% p-p for the first 200 ns on a 100 MHz oscilloscope when used with 10 in (25.4 cm) ground lead. <10% p-p typical after first 200 ns; \pm 5% after the first 400 ns.
Temperature coefficient of DC attenuation	0.006% per degree C ¹
Voltage coefficient of DC attenuation	0.018% per kV
Delay time	10 ft cable: 14.7 ns

¹ Resistor temperature rose 60°C at 15 kV rms over a 30-minute period.

Specifications

Table 1-6: Nominal Mechanical Characteristics

Characteristic	Information
Diameter (probe body)	8.9 cm (3.5 in) maximum
Length (probe body)	34.5 cm (13.6 in)
Length (cable) 10-ft cable	3.05 m (10 ft)
Compensation box	2.5 × 4.1 × 8.3 cm (1 × 1.6 × 3.25 in)
Net weight (probe assembly) 10-ft cable	0.66 kg (1.47 lbs)
Shipping weight (including accessories) 10-ft cable	2.85 kg (6.27 lbs)



WARNING

The following servicing instructions are for use only by qualified personnel. To avoid injury, do not perform any servicing other than that stated in the operating instructions unless you are qualified to do so. Refer to all safety summaries before performing any service.



Service Information



Performance Verification

The performance verification procedure verifies that the P6015A performs as described in the *Specifications* section of Chapter 1. This procedure can also be used as an acceptance check. The procedure is given in the next section, *Adjustments*.

The performance verification consists of the long-form compensation procedure with an additional step to check bandwidth and rise time:

1. Check DC attenuation and adjust if necessary
2. Check low-frequency compensation and adjust if necessary
3. Check transient response and adjust if necessary
4. Check bandwidth and calculate rise time



Adjustments

Recalibration ordinarily is necessary only if the P6015A is being used on a different oscilloscope input or at a drastically different temperature than that at which it was calibrated (a difference greater than $\pm 15^{\circ}\text{C}$). The adjustments necessary for recalibration under these conditions are accessible through holes in the top cover of the compensation box. The basic probe compensation procedure is given in the *In Detail* section of Chapter 1 in this manual.

Limits, tolerances, and waveforms in this procedure are given as adjustment guides. Refer to the *Specifications* section of this manual for actual performance criteria.

Any needed maintenance should be performed before proceeding with compensation. Troubles that become apparent during compensation should be corrected immediately.

Test Equipment Required

The test equipment listed in Table 2-1 (or its equivalent) is required for completion of this procedure. If equipment is substituted, control settings or test equipment setup may need to be altered.

Preparation

Warm up the test equipment at least 20 minutes to stabilize it before performing the checks and adjustments.

Table 2- 1: Test Equipment Required for Long-Form Adjustment

Item	Minimum Requirements	Recommended Example	Application
Oscilloscope	Input Impedance: 1 M Ω Sensitivity: 1 mV/div Bandwidth: \geq 100 MHz	Tektronix 11402A with 11A32 plug-in, or Tektronix TDS 460	All checks and adjustments
Calibration Generator	Rise time: \leq 10 ns Repetition rate: 1 MHz Amplitude: \geq 50 V	Tektronix PG 506A ^{1,2}	All checks and adjustments other than bandwidth
Leveled Sine Wave Generator	Range: 50 kHz to 75 MHz Amplitude: \geq 5V	Tektronix SG 503 ²	Bandwidth check
BNC Male-to-GR Adapter		Tektronix part number 017-0064-00	All checks and adjustments
BNC 50 Ω Termination		Tektronix part number 011-0049-01	Transient response check and adjustment, bandwidth check

¹ Oscilloscopes with less than 1 mV/div sensitivity can be used while making most checks and adjustments. However, because of the 1000X probe attenuation, the system will not display sufficient deflection for optimum adjustment of transient response unless a calibration generator having higher amplitude output is substituted.

² Requires TM 500 or TM 5000 Series Power Module or equivalent.

Long-Form Procedure

The long-form compensation procedure typically should be necessary only under these conditions:

- the probe head or compensation box has been replaced
- the probe has come out of compensation because of aging effects over a prolonged period

Access to adjustments in this procedure requires removal of the top half of the compensation box (Figure 2-1). When reinstalling the top, note that the edges are asymmetrical and that the top will seat securely only when it is correctly oriented. This ensures that the adjustment holes are properly aligned with the circuit board.

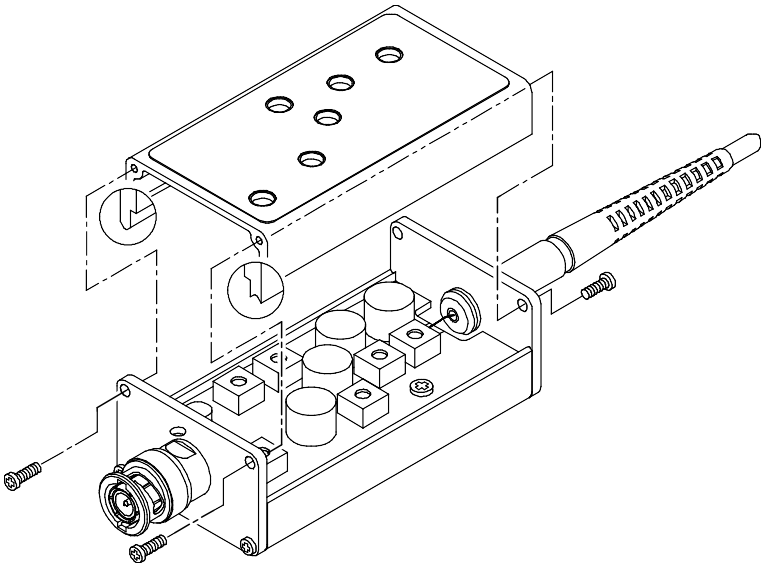

Figure 2- 1: Access to Long-Form Adjustments

The long-form adjustment procedure consists of three parts which must be performed in this order:

1. DC attenuation check and adjustment
2. Low-frequency compensation check and adjustment
3. Transient response check and adjustment

A fourth step, verification of bandwidth and rise time, is performed only when this procedure is used as a performance verification procedure.

DC Attenuation

1. Connect the P6015A compensation box to the oscilloscope.
2. Connect a BNC male-to-GR adapter to the calibration generator high/standard amplitude output. Connect the P6015A ground lead to the outer fin of the GR connector.



WARNING. *The calibration generator produces hazardous voltages during these procedures. To avoid electrical shock, be careful not to touch the GR center conductor or exposed portions of the probe tip while the generator is on.*

3. Insert the P6015A tip into the GR center conductor.
4. Set the calibration generator to standard amplitude output of 50 Volts. This setting on a PG 506A produces a 1 kHz square wave.
5. Set the oscilloscope time base to display 500 $\mu\text{s}/\text{div}$ and set the vertical deflection to 10 mV/div (10 V/div when using the readout option).
6. Center the waveform on the screen.
7. The waveform amplitude should be between 4.85 and 5.15 divisions. If necessary, adjust **R9** for five divisions. Use the trailing portion of the square wave if the leading corner is not flat. See Figure 2-2 for the location of this and other adjustments.

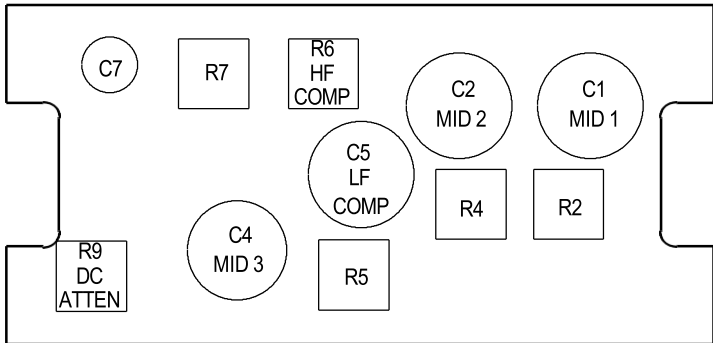

Figure 2-2: Adjustment Locations

Low-Frequency Compensation

1. Set the calibration generator to high amplitude output and set the period to 1 ms. Set the pulse amplitude to display five divisions.
2. Set the oscilloscope time base to display 200 $\mu\text{s}/\text{div}$.
3. Center the waveform on the screen.
4. The leading corner of the square wave should be level with the trailing corner. If necessary, adjust **C5**.
5. The top of the waveform should be flat to within $\pm 5\%$ (± 1.25 minor divisions). If necessary, perform steps 6 through 8.

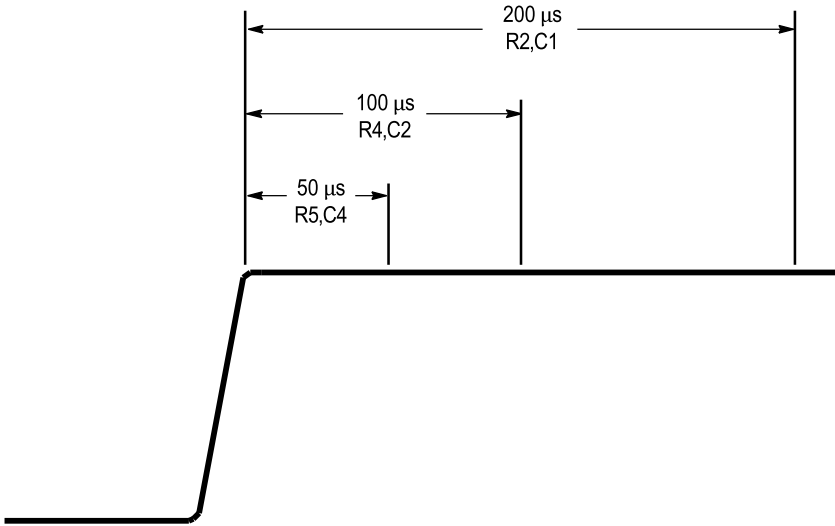

Figure 2-3: Periods Affected by Compensation Adjustments

6. Adjust **R2** and **C1** to flatten the area 200 μs from the leading corner. Refer to Figure 2-3 to locate the zones affected by the adjustments in this and the following steps.

NOTE. *Figure 2-3 shows an idealized waveform. The displayed waveform will include some ground lead ringing.*

7. Adjust **R4** and **C2** to flatten the area 100 μs from the leading corner.
8. Adjust **R5** and **C4** to flatten the area 50 μs from the leading corner.

Adjustments R2, R4, R5, C1, C2, C4, and C5 interact. Steps 4 and 6 through 8 may have to be repeated several times to achieve optimum flatness.

Transient Response

1. Set the calibration generator pulse amplitude to minimum.
2. Set the calibration generator to output a square wave with rise time ≤ 10 ns. If you are using a PG 506A, do this by inserting a 50Ω termination between the high/standard amplitude output and the BNC male-to-GR adapter.
3. Set the oscilloscope time base to display 100 ns/div. Set the oscilloscope vertical deflection to 1 mV/div (1 V/div when using the readout option).
4. Set the calibration generator period to 1 μ s and set the pulse amplitude to display five divisions.
5. Center the waveform on the screen.
6. The waveform should be flat overall, and the front corner should be sharp without overshoot. If necessary, perform steps 7 and 8.
7. Adjust **R6** for overall flatness of the front corner.
8. Adjust **R7** and **C7** for a sharp front corner without overshoot.

There is interaction between R6, R7, and C7. You may have to repeat steps 7 and 8 to obtain optimum response.

Bandwidth and Rise Time Verification

The following check is part of the performance verification procedure. You may omit it if you are performing the adjustment procedure.

1. Substitute the sine wave generator for the calibration generator.
2. Set the oscilloscope vertical deflection to 1 mV/div (1 V/div when using the readout option), and set the time base to display 10 μ s/div.
3. Set the generator frequency to 50 kHz and set the amplitude to display five divisions peak-to-peak.
4. Increase the generator frequency to:
 - 75 MHz for a 10 ft. (3 m) cable.
while observing the oscilloscope display. Set the generator frequency to the point of lowest amplitude at or below 75 MHz (10 ft. cable)
5. The amplitude of the waveform should be at least 3.5 divisions (0.707 of the amplitude in Step 3).

This procedure does not check rise time directly, but it can be approximated by the ratio $t_r = 0.35 / \text{bandwidth}$.

Maintenance

The P6015A ordinarily requires very little maintenance except for occasional cleaning. This section provides procedures for preventive maintenance, corrective maintenance, and removal and replacement of parts.

Preventive Maintenance

Preventive maintenance for the P6015A consists of cleaning and visual inspection.



CAUTION. *Do not attempt to remove the rubber cushioning ring from the front of the probe. The ring is bonded to the probe body, and removal of the ring may cause poor probe response or probe damage.*

Cleaning

Accumulation of dirt on the probe body can provide a conduction path that will result in electrical failure. The following procedures describe how to clean the probe.



CAUTION. *To prevent damage to the probe, do not expose it to sprays, liquids, solvents, or chemical cleaning agents. Avoid using chemicals that contain benzene, toluene, xylene, acetone, or similar solvents.*

Probe Body. The part of the probe that is most vulnerable to arcing is the space between the probe tip and the shield sleeve as shown in Figure 2 -4 on page 2 -14. Inspect this area for dirt accumulation. When necessary, clean the probe with a dry, lint-free cloth or a soft-bristle brush. If dirt remains, use a soft cloth or swab dampened with a 75% isopropyl alcohol solution. A swab is useful for cleaning narrow spaces on the probe, use only enough solution to dampen the

swab or cloth. Do not use abrasive compounds on any part of the probe.

Compensation Box. Cleaning the interior of the compensation box should seldom be necessary. If cleaning is necessary, blow off any accumulated dust with dry, low-velocity air stream. Remove any dirt that remains with a soft brush. A cotton-tipped swab is useful for cleaning in narrow spaces or for cleaning the circuit components.

Visual Inspection

Inspect the circuitry within the compensation box periodically for loosely seated or heat-damaged components. The corrective action for most visible defects is obvious; however, particular care must be taken if heat-damaged parts are found. Overheating usually indicates other problems in the probe or misuse; therefore, correct the cause of overheating to prevent recurrence of the damage.

Troubleshooting and Repair

There are two repair options you should consider:

- Tektronix Repair — You can ship your P6015A probe to us for repair.
- Customer Repair — You can choose to repair the probe yourself. If you decide to repair the probe yourself, order the replacement part from your local Tektronix, Inc. service center or representative. See *Replaceable Parts* for part numbers.

Troubleshooting

Before using the probe, make sure it is properly compensated. Compensate the probe to the vertical channel of the oscilloscope you plan to use. Do not compensate it on one channel, then use it on another. Also, check the vertical and horizontal system controls on your oscilloscope to ensure that they are properly set to display the signal from the device under test.

Mechanical Disassembly and Assembly

This section contains mechanical procedures to aid in the replacement of parts within the probe head and compensation box assemblies.

NOTE. *Perform the long-form compensation procedure after replacing a part.*

Probe Head

The probe head consists of the parts shown in Figure 2-4. Refer to that figure while performing the following steps to replace the inner body or other parts.

Do Not Remove Rubber Ring



CAUTION. *Do not attempt to remove the rubber cushioning ring at the front of the inner probe body or the probe may be damaged and its high voltage performance degraded. This ring is firmly attached with an adhesive and is not designed to be removed.*

Do Not Disassemble Inner Body



CAUTION. *Do not attempt to disassemble the inner body assembly. There are no user serviceable components in the inner body assembly, and attempting to open the inner body assembly may result in damage to its internal structure.*

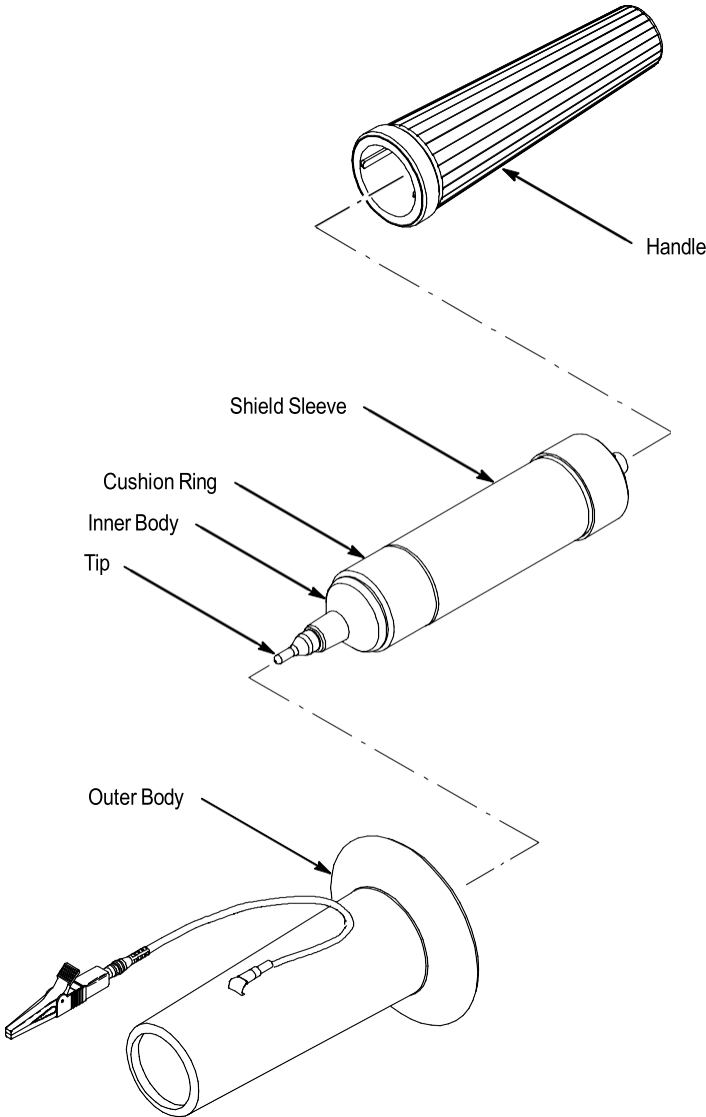

Figure 2-4: Removal and Replacement of Probe Head

Removal.

1. Unscrew the probe tip.
2. Unscrew the plastic probe handle from the outer body, and slide the handle back on the cable. Slide the plastic outer body off the front of the assembly.
3. Disconnect the cable BNC from the assembly.

Replacement.

1. Insert the ground lead connector through the slot in the outer body. Insert the inner body assembly into the outer body. You may have to lift up and forward on the ground lead to allow the assembly to pass.
2. Connect the cable to the probe head BNC.
3. Screw the handle in place.
4. Replace the tip.

Compensation Box

The compensation box assembly contains three parts that can be replaced individually: the compensation box/circuit board assembly, the cable, and the BNC that connects to the oscilloscope or other instrument. Follow these procedures to replace either the cable or the BNC, or to install them on a new compensation box. The procedures are the same in each case.

Removal.

1. Remove the top half of the compensation box.
2. Unsolder the cable (or BNC) center conductor.
3. Unscrew the cable bushing (or BNC).

Replacement.

1. Screw the cable bushing (or BNC) into the end plate.
2. Form the conductor to the solder pad on the circuit board, then solder the conductor in place.
3. Replace the top half of the compensation box. Note that the edges are asymmetrical (as shown previously in Figure 2-1) and that the top will seat securely only when it is correctly oriented. This ensures that the adjustment holes are properly aligned with the circuit board.

Replaceable Parts

This section contains a list of the components that are replaceable for the P6015A. As described below, use this list to identify and order replacement parts.

Parts Ordering Information

Replacement parts are available from or through your local Tektronix, Inc. service center or representative.

Changes to Tektronix instruments are sometimes made to accommodate improved components as they become available and to give you the benefit of the latest circuit improvements. Therefore, when ordering parts, it is important to include the following information in your order:

- Part number
- Probe type or model number, including option numbers
- Probe serial number
- Probe modification number, if applicable

The P6015A is serviced by module replacement. In some cases you may exchange your module for a remanufactured module. These modules cost significantly less than new modules and meet the same factory specifications. For more information, contact your local Tektronix, Inc. service center or representative.

If a part you order has been replaced with a different or improved part, your local Tektronix service center or representative will contact you concerning any change in the part number.

Change information, if any, is located at the rear of this manual.

Using the Replaceable Parts List

The tabular information in the Replaceable Parts List is arranged for quick retrieval. Understanding the structure and features of the list will help you find all the information you need for ordering replacement parts.

Item Names

In the Replaceable Parts List, an Item Name is separated from the description by a colon (:). Because of space limitations, an Item Name may sometimes appear as incomplete. For further Item Name identification, U.S. Federal Cataloging Handbook H6-1 can be used where possible.

Abbreviations

Abbreviations conform to American National Standards Institute (ANSI) standard Y1.1

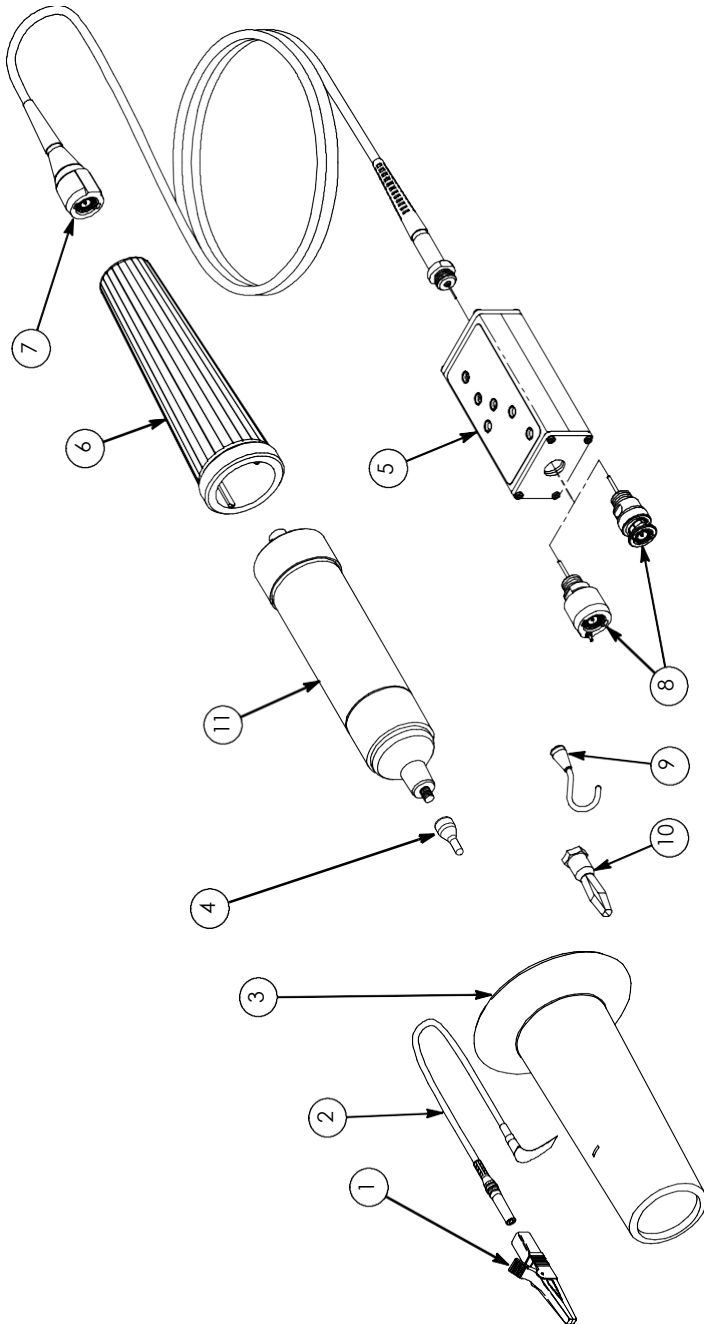

Figure 2-5: P6015A Exploded View

Fig. & Index No. Tektronix Part No. Serial No. Effective Dscont Qty Name & Description

Fig. & Index No.	Tektronix Part No.	Serial No.	Effective Dscont	Qty	Name & Description
2-5-					STANDARD (10 FT CABLE-NO READOUT)
-1	344-0461-00			1	CLIP,ELEC:CROCODILE,82MM L,4MM
-2	196-3363-00			1	LEAD ELECTRICAL:GROUND,STRD,18 AWG,10.0L
-3	204-1106-00	B019999		1	BODY,PROBE:OUTER,FINISHED
	204-1106-01	B020000		1	BODY,PROBE:OUTER,FINISHED
-4	206-0116-00			1	TIP,PROBE:
-5	119-4636-02			1	PROBE,HV:75MHZ,10 FT;COMP BOX ASSY
-6	367-0438-00			1	HANDLE,PROBE:6.0 L,NYLON,GRAY
-7	174-2579-00			1	CABLE ASSY,RF:50 OHM COAX,10FT L
-8	131-0602-00			1	CONN,RF PLUG:BNC,;50 OHM,MALE,STR, FEEDTHRU/FRONT PNL,1.555 L,0.285 L,0.375-32 THD,0.5L 22 AWG TAB,0.384 DIA MTG
					STANDARD ACCESSORIES
	016-1147-00			1	CASE,CRYG,PROBE:
	070-8223-05			1	MANUAL,TECH:INSTR,P6015A
-9	344-0005-00	B019999		1	CLIP ELECTRICAL:ALLIGATOR,2.5 L,W/PLUG & COVER TIP,HOOK:PROBE
	206-0463-00	B020000		1	
-10	134-0016-00	B020000		1	PLUG,TIP:BANANA,10-32 INT THD END
-11	204-2202-02			1	BODY ASSY,PROBE; P6015A

Fig. & Index No.	Tektronix Part No.	Serial No. Effective Dscont	Qty	Name & Description
2-5-				OPTION 1R(10FT CABLE-W/READOUT)
-1	344-0461-00		1	CLIP,ELEC:CROCODILE,82MM L,4MM
-2	196-3363-00		1	LEAD ELECTRICAL:GROUND,STRD,18 AWG,10,0L
-3	204-1106-00	B019999	1	BODY,PROBE:OUTER,FINISHED
	204-1106-01	B020000	1	BODY,PROBE:OUTER,FINISHED
-4	204-0116-01		1	BODY,VAR RES:PLASTIC
-5	119-4636-03		1	PROBE,HV:10 FT,W/READOUT:,COMP BOX ASSY
-6	367-0438-00		1	HANDLE,PROBE:6.0 L,NYLON,GRAY
-7	174-2579-00		1	CABLE ASSY,RF:50 OHM COAX,10FT L
-8	131-5320-00		1	CONN,RCPT ASSY:ELEC WITH READOUT
				STANDARD ACCESSORIES
	016-1147-00		1	CASE,CRYG,PROBE:
	070-8223-05		1	MANUAL,TECH:INSTR,P6015A
-9	344-0005-00	B019999	1	CLIP,ELECTRICAL:ALLIGATOR,2.5 L,W/PLUG & COVER TIP,HOOK:PROBE
	206-0463-00	B020000	1	
-10	134-0016-00	B020000	1	PLUG,TIP:BANANA,10-32 INT THD END
-11	204-2202-02		1	BODY ASSY,PROBE; P6015A

Fig. & Index No. Tektronix Part No. Serial No. Effective Dscont

Qty	Name & Description
	OPTION 2R(25FT CABLE-W/READOUT)
-1	344-0461-00 1 CLIP,ELEC:CROCODILE,82MM L,4MM
-2	196-3363-00 1 LEAD ELECTRICAL:GROUND,STRD,18 AWG,10,0L
-3	204-1106-00 B019999 BODY,PROBE:OUTER,FINISHED
	204-1106-01 B020000 BODY,PROBE:OUTER,FINISHED
-4	206-0116-00 1 TIP,PROBE:
-5	119-4636-27 1 PROBE,HV:25 FT,W/READOUT:,COMP BOX ASSY
-6	367-0438-00 1 HANDLE,PROBE:6.0 L,NYLON,GRAY
-7	***** 1 CABLE ASSY,RF:31 OHM COAX,25FT L
-8	131-5320-00 1 CONN,RCPT ASSY:ELEC WITH READOUT
	STANDARD ACCESSORIES
	016-1147-00 1 CASE,CRYG,PROBE
	070-8223-05 1 MANUAL,TECH:INSTR,P6015A
-9	344-0005-00 B019999 CLIP,ELECTRICAL:ALLIGATOR,2.5 L,W/PLUG & COVER
	206-0463-00 B020000 TIP,HOOK,PROBE
-10	134-0016-00 B020000 PLUG,TIP:BANANA,10-32 INT THD END
-11	204-2202-02 1 BODY ASSY,PROBE:, P6015A

2-5-

Fig. & Index No.	Tektronix Part No.	Serial No. Effective Dscont	Qty	Name & Description
2-5-				OPTION 25 (25FT CABLE- NO READOUT)
-1	344-0461-00		1	CLIP,ELEC:CROCODILE,82MM L,4MM
-2	196-3363-00		1	LEAD ELECTRICAL:GROUND,STRD,18 AWG;10.0L
-3	204-1106-00	B019999	1	BODY,PROBE:OUTER,FINISHED
	204-1106-01	B020000	1	BODY,PROBE:OUTER,FINISHED
-4	206-0116-00		1	TIP,PROBE:
-5	119-4636-28		1	PROBE,HV;25 FT,W/NO READOUT;COMP BOX ASSY
-6	367-0438-00		1	HANDLE,PROBE:6.0 L,NYLON,GRAY
-7	-----		1	CABLE ASSY,RF:31 OHM COAX,25 FT L
-8	131-0602-00		1	CONN,RF PLUG:BNC,;50 OHM,MALE,STR, FEEDTHRU/FRONT PNL,1.555 L,0.285 L 0.375-32 THD,0.5L 22 AWG TAB,0.384 DIA MTG
-9				STANDARD ACCESSORIES
	016-1147-00		1	CASE,CRYG,PROBE:
	070-8223-05		1	MANUAL,TECH:INSTR,P6015A
	344-0005-00	B019999	1	CLIP,ELECTRICAL:ALLIGATOR,2.5 L,W/PLUG & COVER TIP,HOOK:PROBE
	206-0463-00	B020000	1	
-10	134-0016-00	B020000	1	PLUG,TIP:BANANA,10-32 INT THD END
-11	204-2202-02		1	BODY ASSY,PROBE; P6015A



Index

Index

A

- accessories, standard, *1-4*
- adjustments
 - access, *2-5*
 - DC attenuation, *2-6*
 - long-form procedure, *2-5*
 - low-frequency compensation,
2-7
 - preparation, *2-3*
 - test equipment required, *2-3, 2-4*
 - transient response, *2-9*

C

- calibration, period, *2-3*
- characteristics, *1-21, 1-25*
 - aberrations, *1-25*
 - altitude, *1-23*
 - bandwidth, *1-22*
 - calibration temperature, *1-21*
 - DC attenuation, *1-22*
 - delay time, *1-25*
 - general, *1-1*
 - humidity, *1-23*
 - input capacitance, *1-25*
 - input impedance, *1-24*
 - input resistance, *1-25*
 - low-frequency compensation,
1-25
 - maximum input voltage, *1-9, 1-22*
 - frequency derating curve, *1-10*
 - peak pulse derating, *1-11*
 - mechanical, *1-26*
 - operations, *1-21*
 - rise time, *1-22*
 - shock, *1-23*

- temperature, *1-23, 1-25*
- vibrations, *1-23*
- voltage, *1-25*
- warm-up period, *1-21*
- compensation box
 - assembly, *2-16*
 - cleaning, *2-12*
 - description, *1-1*
- Contacting Tektronix, ix
- crocodile clip, *1-6*
- cushioning ring, *2-11*

D

- distortion, high-frequency, *1-19*

G

- general information, *1-1*
- ground lead
 - distortion, *1-19*
 - inductance, *1-12*
 - lead length, *1-12*
 - ringing, *1-19, 2-8*
 - safety, *1-9, 1-11*

M

- maintenance
 - assembly, *2-13*
 - cleaning, *2-11*
 - general, *2-11*
 - probe care, *1-18*
 - probe cleaning, *1-18*
 - solvents, *1-18*
 - visual inspection, *2-12*

O

- operation, guidelines, 1-7
- options, 1-4
 - readout, 1-3, 1-8

P

- performance verification, general, 2-1
- Phone number, Tektronix, ix
- probe
 - assembly, 1-5, 2-13, 2-14, 2-15
 - body, 1-1
 - cleaning, 2-11
- probe compensation, 1-13
 - long-form, 1-13
 - short-form, 1-13
 - DC attenuation, 1-15
 - low-frequency, 1-16
 - transient response, 1-17
 - test equipment required, 1-13
- probe grounding, 1-11
 - inductance, 1-12
 - power cord, 1-12
 - ringing, 1-12
 - voltage differential, 1-12
- problems, 1-19
 - front-panel controls, 1-19
 - grounding, 1-19
 - input capacitance, 1-19
 - low frequency compensation, 1-19
- Product support, contact information, ix

R

- repair, 2-12
- replacement parts
 - abbreviations, 2-18
 - general, 2-17
 - item names, 2-18
 - ordering, 2-17
 - probe, 20
- ringing
 - ground lead, 1-19
 - power cord, 1-12

S

- Service support, contact information, ix
- solvents, 2-11
- specifications. *See characteristics*

T

- Tektronix, contacting, ix
- temperature, considerations, 1-19
- troubleshooting, general, 2-12

V

- verification
 - bandwidth, 2-10
 - rise time, 2-10