

**P6900 Series
High-Density Logic Analyzer Probes
with D-Max™ Probing Technology
Instruction Manual**

Warning

The servicing instructions are for use by qualified personnel only. To avoid personal injury, do not perform any servicing unless you are qualified to do so. Refer to all safety summaries prior to performing service.

www.tektronix.com



077-1528-06

Tektronix

Copyright © Tektronix. All rights reserved. Licensed software products are owned by Tektronix or its subsidiaries or suppliers, and are protected by national copyright laws and international treaty provisions.

Tektronix products are covered by U.S. and foreign patents, issued and pending. Information in this publication supersedes that in all previously published material. Specifications and price change privileges reserved.

TEKTRONIX and TEK are registered trademarks of Tektronix, Inc.

Contacting Tektronix

Tektronix, Inc.
14150 SW Karl Braun Drive
P.O. Box 500
Beaverton, OR 97077
USA

For product information, sales, service, and technical support:

- In North America, call 1-800-833-9200.
- Worldwide, visit www.tektronix.com to find contacts in your area.

Warranty

Tektronix warrants that this product will be free from defects in materials and workmanship for a period of one (1) year from the date of shipment. If any such product proves defective during this warranty period, Tektronix, at its option, either will repair the defective product without charge for parts and labor, or will provide a replacement in exchange for the defective product. Parts, modules and replacement products used by Tektronix for warranty work may be new or reconditioned to like new performance. All replaced parts, modules and products become the property of Tektronix.

In order to obtain service under this warranty, Customer must notify Tektronix of the defect before the expiration of the warranty period and make suitable arrangements for the performance of service. Customer shall be responsible for packaging and shipping the defective product to the service center designated by Tektronix, with shipping charges prepaid. Tektronix shall pay for the return of the product to Customer if the shipment is to a location within the country in which the Tektronix service center is located. Customer shall be responsible for paying all shipping charges, duties, taxes, and any other charges for products returned to any other locations.

This warranty shall not apply to any defect, failure or damage caused by improper use or improper or inadequate maintenance and care. Tektronix shall not be obligated to furnish service under this warranty a) to repair damage resulting from attempts by personnel other than Tektronix representatives to install, repair or service the product; b) to repair damage resulting from improper use or connection to incompatible equipment; c) to repair any damage or malfunction caused by the use of non-Tektronix supplies; or d) to service a product that has been modified or integrated with other products when the effect of such modification or integration increases the time or difficulty of servicing the product.

THIS WARRANTY IS GIVEN BY TEKTRONIX WITH RESPECT TO THE PRODUCT IN LIEU OF ANY OTHER WARRANTIES, EXPRESS OR IMPLIED. TEKTRONIX AND ITS VENDORS DISCLAIM ANY IMPLIED WARRANTIES OF MERCHANTABILITY OR FITNESS FOR A PARTICULAR PURPOSE. TEKTRONIX' RESPONSIBILITY TO REPAIR OR REPLACE DEFECTIVE PRODUCTS IS THE SOLE AND EXCLUSIVE REMEDY PROVIDED TO THE CUSTOMER FOR BREACH OF THIS WARRANTY. TEKTRONIX AND ITS VENDORS WILL NOT BE LIABLE FOR ANY INDIRECT, SPECIAL, INCIDENTAL, OR CONSEQUENTIAL DAMAGES IRRESPECTIVE OF WHETHER TEKTRONIX OR THE VENDOR HAS ADVANCE NOTICE OF THE POSSIBILITY OF SUCH DAMAGES.

[W2 – 15AUG04]

Table of Contents

Preface	v
Related documentation	v
Environmental considerations	vi
Commonly used terms	vi
Operating basics	1
Product description	1
Connect the probes to the logic analyzer	10
Connect the probes to the target system	11
Dress the probe cables	19
Store the probe heads	20
Reference	21
Probe and target system interface design information	21
Board design	27
Probe footprint dimensions	35
Other design considerations	36
Probe pinout definition and channel assignment	37
Specifications	53
Mechanical and electrical specifications	53
Maintenance	55
Probe calibration	55
Perform the functional check	55
Inspect and clean the probes	55
Service strategy	56
Legacy probe and attachment support	56
Repackaging instructions	57
Replaceable parts	59
Parts ordering information	59
Replaceable parts list	60
Index	

List of Figures

Figure i: Differential input amplitude	vii
Figure ii: Flying lead set.....	vii
Figure iii: Probe example.....	viii
Figure 1: P6960 High-Density probe with D-Max probing technology.....	2
Figure 2: P6960HS High-Density probe with D-Max probing technology	3
Figure 3: P6962 High-Density probe with D-Max probing technology.....	4
Figure 4: P6964 High-Density probe with D-Max probing technology.....	6
Figure 5: P6980 High-Density Differential probe with D-Max probing technology	7
Figure 6: P6982 High-Density Differential probe with D-Max probing technology	8
Figure 7: Connecting the probes to the logic analyzer	10
Figure 8: Replacing the wires on the retention posts	11
Figure 9: Installing the retention posts in the PCB	12
Figure 10: Soldering the retention posts in the PCB	13
Figure 11: Installing the alternate retention assembly.....	14
Figure 12: Proper handling of the interface clip	15
Figure 13: Connecting the probes to the target system.....	16
Figure 14: Using the flying lead set to connect to the target system.....	18
Figure 15: Proper dressing of the probe cables	19
Figure 16: Protecting the probe heads.....	20
Figure 17: P6960, P6960HS, P6980, and P6982 probe dimensions	27
Figure 18: P6962 and P6964 probe dimensions.....	28
Figure 19: Retention post dimensions.....	29
Figure 20: Keepout area	29
Figure 21: Side-by-side layout.....	30
Figure 22: End-to-end layout	30
Figure 23: Alternate retention assembly dimensions.....	30
Figure 24: Keepout area	31
Figure 25: Side-by-side layout.....	31
Figure 26: End-to-end layout	32
Figure 27: Signal routing on the target system.....	32
Figure 28: High-Density probe load model.....	34
Figure 29: Probe footprint dimensions on the PCB.....	35
Figure 30: Optional Via-in-pad placement recommendation	36
Figure 31: P6960/P6960HS single-ended PCB footprint pinout detail.....	37
Figure 32: P6962 single-ended PCB footprint pinout detail.....	39
Figure 33: P6964 single-ended PCB footprint pinout detail.....	41
Figure 34: P6980 differential PCB footprint pinout detail.....	44
Figure 35: P6982 differential PCB footprint pinout detail.....	48

Figure 36: Replacing the cLGA clip	56
Figure 37: P6960 High-Density probe accessories	61
Figure 38: P6960HS High-Density probe accessories	62
Figure 39: P6962 High-Density probe accessories	63
Figure 40: P6964 High-Density probe accessories	64
Figure 41: P6980 High-Density Differential probe accessories.....	65
Figure 42: P6982 High-Density Differential probe accessories.....	66
Figure 43: Optional accessories.....	67

List of Tables

Table 1: Logic analyzer clock and qualifier availability	22
Table 2: 2X Demultiplexing source-to-destination channel assignments	24
Table 3: 4X Demultiplexing source-to-destination channel assignments	25
Table 4: Channel assignment for P6960/P6960HS single-ended data, differential clock logic analyzer probes	37
Table 5: Channel assignment for a P6962 single-ended data, differential clock logic analyzer probe...	40
Table 6: Channel assignment for a P6964 single-ended data, differential clock logic analyzer probe...	42
Table 7: Channel assignment for a P6980 differential clock and data logic analyzer probe to a 136- or 102-channel logic analyzer module	44
Table 8: Channel assignment for a P6980 differential clock and data logic analyzer probe to a 68- or 34-channel logic analyzer module	46
Table 9: Channel assignment for a P6982 differential clock and data logic analyzer probe to a 136- or 102-channel logic analyzer module	48
Table 10: Channel assignment for a P6982 differential clock and data logic analyzer probe to a 68- or 34-channel logic analyzer module	50
Table 11: Mechanical and electrical specifications	53
Table 12: Environmental specifications	54
Table 13: Parts list column descriptions	60
Table 14: P6960 replaceable parts list	61
Table 15: P6960HS replaceable parts list	62
Table 16: P6962 replaceable parts list	63
Table 17: P6964 replaceable parts list	64
Table 18: P6980 replaceable parts list	65
Table 19: P6982 replaceable parts list	66
Table 20: P6900 Series Probes optional accessories	67

Preface

This document provides information on using and servicing the P6900 Series logic analyzer probes.

Related documentation

The following list and table provide information on the related documentation available for your Tektronix product. For additional information, refer to the Tektronix Web site (www.tektronix.com/manuals).

Related documentation

Item	Purpose
TLA Quick Start User Manuals	High-level operational overview
Online Help	In-depth operation and UI help
Installation Reference Sheets	High-level installation information
Installation Manuals	Detailed first-time installation information
XYZs of Logic Analyzers	Logic analyzer basics
Declassification and Securities instructions	Data security concerns specific to sanitizing or removing memory devices from Tektronix products
Application notes	Collection of logic analyzer application specific notes
Product Specifications & Performance Verification Procedures	TLA Product specifications and performance verification procedures
TPI.NET Documentation	Detailed information for controlling the logic analyzer using .NET
Field upgrade kits	Upgrade information for your logic analyzer
Optional Service Manuals	Self-service documentation for modules and mainframes

Environmental considerations

This section provides information about the environmental impact of the product.

Product end-of-life handling

Observe the following guidelines when recycling an instrument or component:

Equipment recycling. Production of this equipment required the extraction and use of natural resources. The equipment may contain substances that could be harmful to the environment or human health if improperly handled at the product's end of life. In order to avoid release of such substances into the environment and to reduce the use of natural resources, we encourage you to recycle this product in an appropriate system that will ensure that most of the materials are reused or recycled appropriately.



This symbol indicates that this product complies with the applicable European Union requirements according to Directives 2002/96/EC and 2006/66/EC on waste electrical and electronic equipment (WEEE) and batteries. For information about recycling options, check the Support/Service section of the Tektronix Web site (www.tektronix.com).

Restriction of hazardous substances

This product is classified as an industrial monitoring and control instrument accessory, and is not required to comply with the substance restrictions of the recast RoHS Directive 2011/65/EU until July 22, 2017.

Commonly used terms

Refer to the following list of commonly used terms throughout the manual.

cLGA An acronym for compression Land Grid Array, a connector that provides an electrical connection between a PCB and the probe input circuitry.

Compression Footprint

A connectorless, solderless contact between your PCB and the P6900 Series probes. Connection is obtained by applying pressure between your PCB and the probe through a cLGA c-spring.

Differential Input Amplitude Definition

For differential signals, the magnitude of the difference voltage $V_{max}-V_{min}$ (and $V_{min}-V_{max}$) must be greater than or equal to 150 mV.

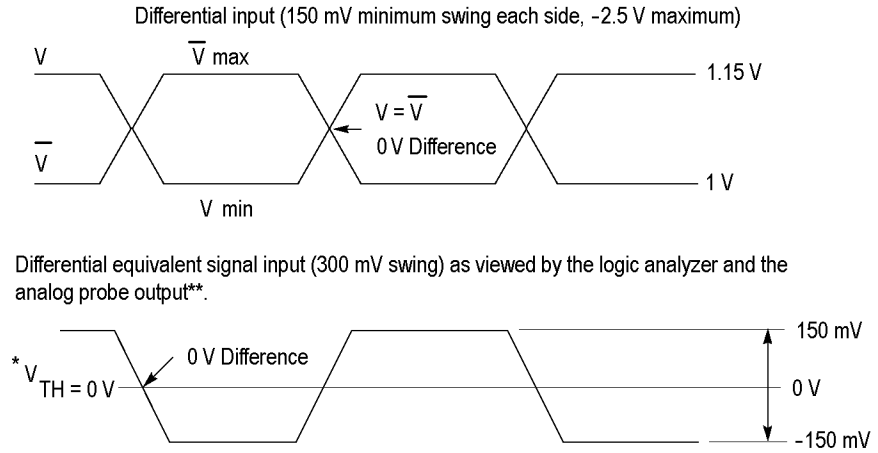

* Note: For differential inputs, the module threshold should be set to 0 V (assuming no common mode error).

** Note: See online help for further analog output details.

0141-001

Figure i: Differential input amplitude

D-Max probing technology

Trademark name that describes the technology used in the P6900 Series high-density logic analyzer probes.

Flying Lead Set

A lead set designed to attach to a P6960 Probe to provide general-purpose probing capability. (See Figure ii.)

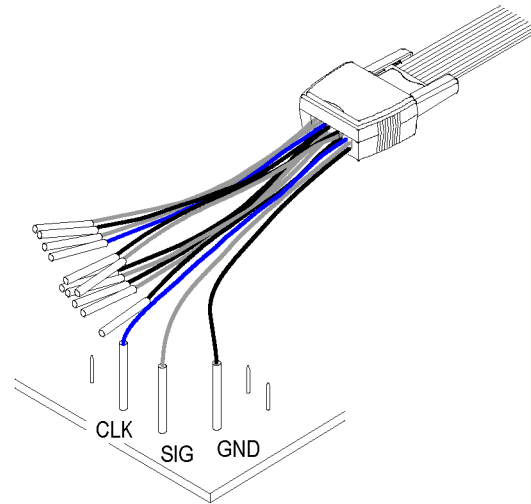

Figure ii: Flying lead set

- Functional Check Procedure** Functional check procedures verify the basic functionality of the probes by confirming that the probes recognize signal activity at the probe tips.
- Keepout Area** An area on a printed circuit board in which component, trace, and/or via placement may be restricted.
- Module** The unit that plugs into a mainframe that provides instrument capabilities such as logic analysis.
- Module End** The end of the probe that plugs into the module unit.
- PCB** An acronym for Printed Circuit Board; also known as Etched Circuit Board (ECB).
- Probe** The device connects a module with a target system. (See Figure iii.)

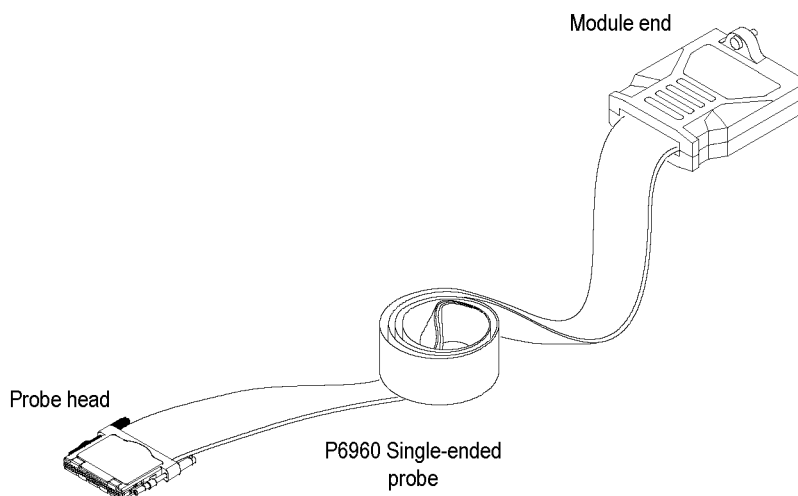

Figure iii: Probe example

- Probe Adapter** A device that connects the LA module probe to a target system.
- Probe Head** The end of the probe that connects to the target system or probe adapter.
- SMT KlipChip** An interface device for attaching logic analyzer probes to components with a maximum lead diameter of 2.413 mm (0.095 in) and stackable on lead centers of 1.27 mm (0.050 in).

Operating basics

This section provides a brief description of the Tektronix P6900 Series High-Density Logic Analyzer Probes, information on attaching color-coded probe labels, and probe and adapter connection instructions from the logic analyzer to the target system.

Product description

The P6900 Series Probes connect TLA7ACx Series Logic Analyzer modules to a target system.

- The P6960, P6960HS, P6962, and P6964 probes consist of 32 single-ended channels and two (2) differential channels in one probe head.
- The P6980 probe consists of 34 channels in two probe heads, with each head containing 17 differential channels.
- The P6982 probe consists of 17 differential channels in one probe head.

Probe labels

If you purchase probes for the logic analyzer module, you will need to apply the color-coded labels. You will find instructions on how to attach the labels to the probes on a color reference card that is included with the probes:

- *P6960 High Density Logic Analyzer Probe Labeling and Installation Instructions*
- *P6962 High Density Logic Analyzer Probe Labeling and Installation Instructions*
- *P6964 High Density Logic Analyzer Probe Optimized for 4X Demultiplexing Labeling and Installation Instructions*
- *P6980 High Density Differential Logic Analyzer Probe Labeling and Installation Instructions*
- *P6982 High Density Differential Logic Analyzer Optimized for 2X Demultiplexing Probe Labeling and Installation Instructions*

P6960 High-Density Probe

The P6960 Probe is a 34-channel, high-density connectorless probe with D-Max probing technology. (See Figure 2.) The probe consists of one probe head that has 34 channels (32 data and 2 clock/qual).

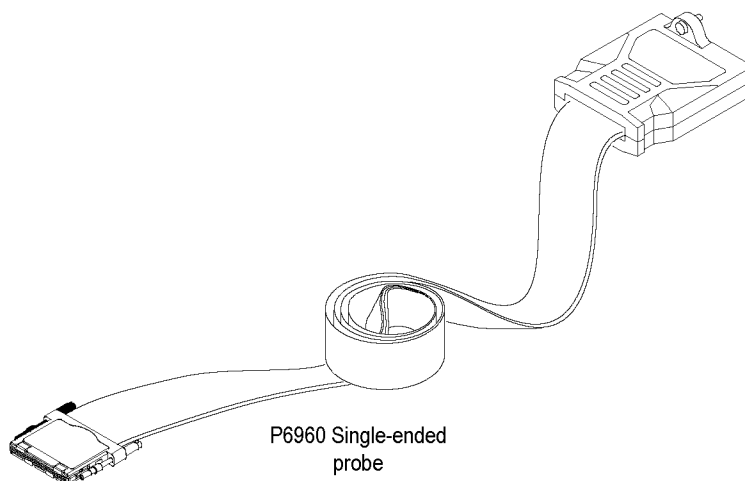

Figure 1: P6960 High-Density probe with D-Max probing technology

The following list details the capabilities and qualities of the P6960 Probe:

- Differential or single-ended clock and qualification inputs
- Single-ended data inputs
- cLGA contact eliminates the need for a built-in connector
- Footprint supports direct signal pass-through
- Supports PCB thickness of 1.27 mm to 6.35 mm (0.050 in to 0.250 in)
- Consists of one independent probe head of 34 channels (32 data and 2 clock/quals)
- Narrow 34-channel probe head makes for easier placement and layout
- 2X mode, (for example, 1:2 demultiplexing) uses one-half of the probe head
- 4X mode, (for example, 1:4 demultiplexing) uses one-quarter of the probe head
- Color-coded keyed attachment
- -2.5 V to +5 V input operating range
- -2.0 V to +4.5 V threshold range
- 300 mV minimum single-ended signal amplitude
- 150 mV amplitude each side minimum differential signal
- Minimal loading of 0.5 pF at 20 k Ω to ground

- Operation in normal or inverted polarity is acceptable (clock only)
- Any common mode voltage is acceptable so long as the maximum positive voltage does not exceed +5 V and the maximum negative voltage does not exceed -2.5 V (clock only)

NOTE. You can find more information about the P6960 probe routing and pinout in the Signal Routing section. (See Figure 27 on page 32.)

P6960HS High-Density Probe

The P6960HS Probe is a 34-channel, high-sensitive, high-density connectorless probe with D-Max probing technology. It has twice the voltage sensitivity compared with the standard P6960 probe. (See Figure 2.) The probe consists of a probe head with 34 channels (32 data and 2 clock/qual).

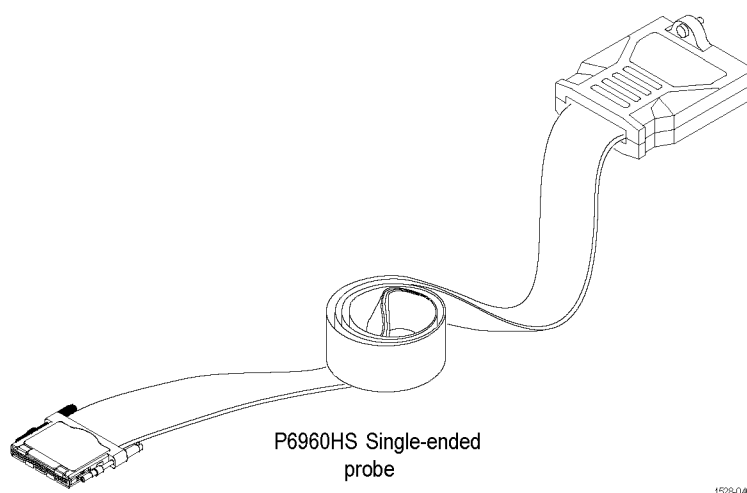

Figure 2: P6960HS High-Density probe with D-Max probing technology

The following list details the capabilities and qualities of the P6960HS Probe:

- Differential or single-ended clock and qualification inputs
- Single-ended data inputs
- cLGA contact eliminates the need for a built-in connector
- Footprint supports direct signal pass-through
- Supports PCB thickness of 1.27 mm to 6.35 mm (0.050 in to 0.250 in)
- Consists of one independent probe head of 34 channels (32 data and 2 clock/quals)
- Narrow 34-channel probe head makes for easier placement and layout
- 2X mode, (for example, 1:2 demultiplexing) uses one-half of the probe head

- 4X mode, (for example, 1:4 demultiplexing) uses one-quarter of the probe head
- Color-coded keyed attachment
- -1.25 V to +2.5 V input operating range
- -1.0 V to +2.25 V threshold range
- 100 mV minimum single-ended signal amplitude
- 50 mV amplitude each side minimum differential signal
- Minimal loading of 0.5 pF at 20 k Ω to ground
- Operation in normal or inverted polarity is acceptable (clock only)
- Any common mode voltage is acceptable so long as the maximum positive voltage does not exceed +2.5 V and the maximum negative voltage does not exceed -1.25 V (clock only)

NOTE. You can find more information about the P6960HS probe routing and pinout in the Signal Routing section. (See Figure 27 on page 32.)

P6962 High-Density Probe

The P6962 Probe is a 34-channel, high-density connectorless probe with D-Max probing technology. (See Figure 3.) The probe consists of one probe head that has 34 channels (32 data and 2 clock/qual), distributed over 2 module-end connectors.

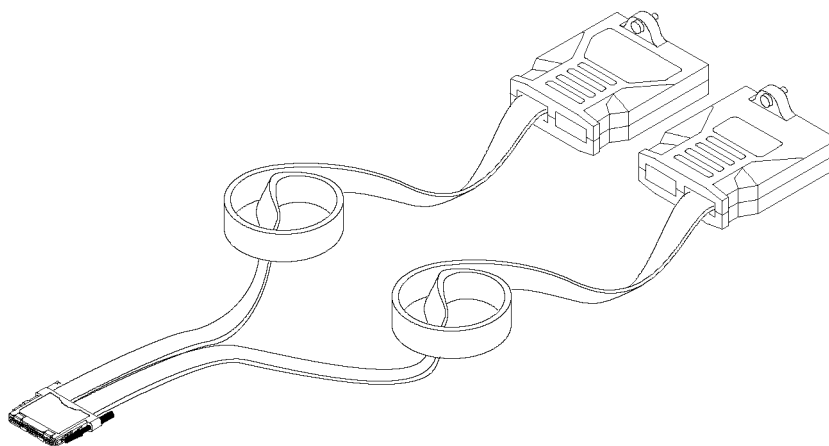

Figure 3: P6962 High-Density probe with D-Max probing technology

The following list details the capabilities and qualities of the P6962 Probe:

- Differential or single-ended clock and qualification inputs
- Single-ended data inputs
- cLGA contact eliminates the need for a built-in connector

- Footprint supports direct signal pass-through
- Supports PCB thickness of 1.27 mm to 6.35 mm (0.050 in to 0.250 in)
- Consists of one independent probe head of 34 channels (32 data and 2 clock/quals)
- Narrow 34-channel probe head makes for easier placement and layout
- Optimized for 4X mode (1:4 demultiplexing) to minimize board real estate
- Color-coded keyed attachment
- -2.5 V to +5 V input operating range
- -2.0 V to +4.5 V threshold range
- 300 mV minimum single-ended signal amplitude
- 150 mV amplitude each side minimum differential signal
- Minimal loading of 0.5 pF at 20 k Ω to ground
- Operation in normal or inverted polarity is acceptable (clock only)
- Any common mode voltage is acceptable so long as the maximum positive voltage does not exceed +5 V and the maximum negative voltage does not exceed -2.5 V (clock only)

NOTE. *You can find more information about the P6962 probe routing and pinout in the P6962 Single-ended Probe with D-Max probing technology section. (See Figure 32 on page 39.)*

P6964 High-Density Probe

The P6964 Probe is a 34-channel, high-density connectorless probe with D-Max probing technology. (See Figure 4.) The probe consists of one probe head that has 34 channels (32 data and 2 clock/qual), distributed over 4 module-end connectors.

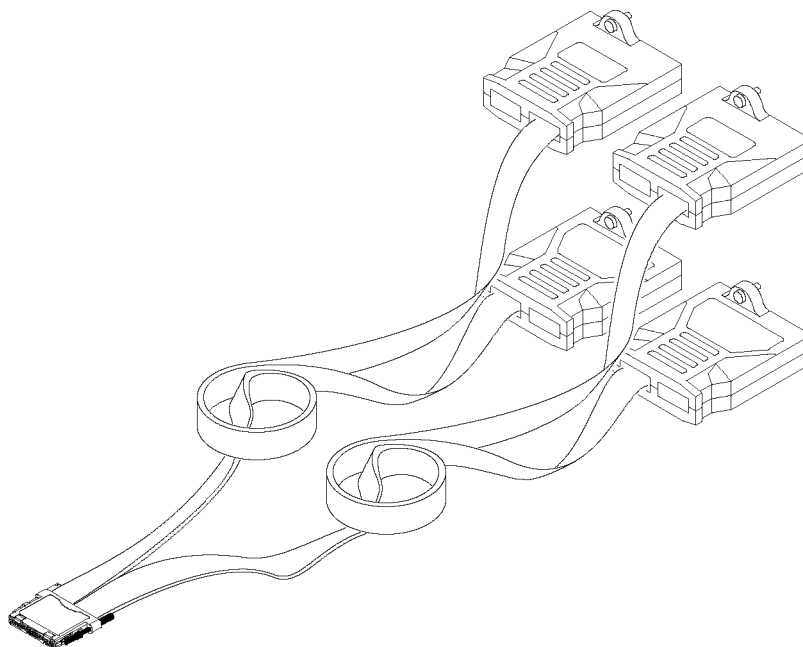

Figure 4: P6964 High-Density probe with D-Max probing technology

The following list details the capabilities and qualities of the P6964 Probe:

- Differential or single-ended clock and qualification inputs
- Single-ended data inputs
- cLGA contact eliminates the need for a built-in connector
- Footprint supports direct signal pass-through
- Supports PCB thickness of 1.27 mm to 6.35 mm (0.050 in to 0.250 in)
- Consists of one independent probe head of 34 channels (32 data and 2 clock/quals)
- Narrow 34-channel probe head makes for easier placement and layout
- Optimized for 4X mode (1:4 demultiplexing) to minimize board real estate
- Color-coded keyed attachment
- -2.5 V to +5 V input operating range
- -2.0 V to +4.5 V threshold range
- 300 mV minimum single-ended signal amplitude
- 150 mV amplitude each side minimum differential signal

- Minimal loading of 0.5 pF at 20 k Ω to ground
- Operation in normal or inverted polarity is acceptable (clock only)
- Any common mode voltage is acceptable so long as the maximum positive voltage does not exceed +5 V and the maximum negative voltage does not exceed -2.5 V (clock only)

NOTE. You can find more information about the P6964 probe routing and pinout in the Signal Routing section. (See Figure 27 on page 32.)

P6980 High-Density Differential Probe

The P6980 Probe is a 34-channel, high-density connectorless differential probe with D-Max probing technology. (See Figure 5.) The probe consists of two independent probe heads of 17 channels each (16 data and 1 clock/qual).

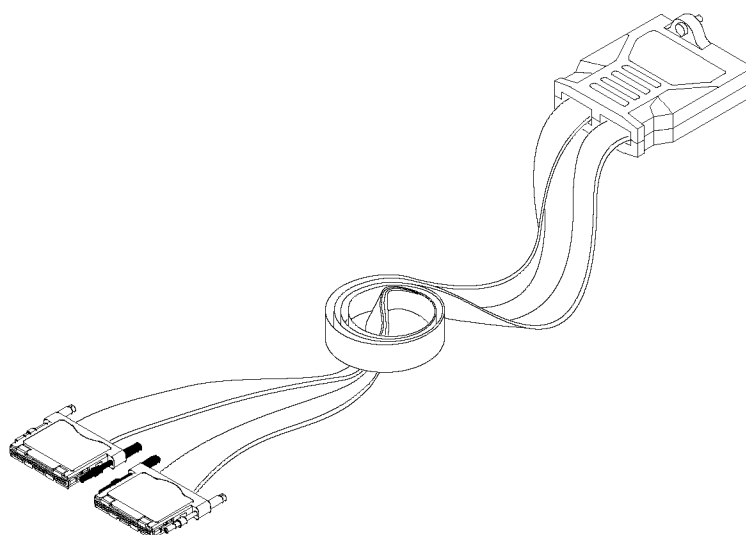

Figure 5: P6980 High-Density Differential probe with D-Max probing technology

The following list details the capabilities and qualities of the P6980 Probe:

- Differential data, clock and qualification inputs (single-ended signals may be probed if negative input is grounded)
- cLGA contact eliminates the need for a built-in connector
- Footprint supports direct signal pass-through
- Supports PCB thickness of 1.27 mm to 6.35 mm (0.050 in to 0.250 in)
- Consists of two probe heads supporting 17 channels each, for a total of 34 channels
- 2X mode (1:2 demultiplexing) and 4X mode (1:4 demultiplexing), use one probe head to minimize required board real estate

- Color-coded keyed attachment
- -2.5 V to +5 V input operating range
- -2.0 V to +4.5 V threshold range
- 300 mV minimum single-ended signal amplitude (5 V maximum)
- 150 mV each side minimum differential signal amplitude (2.5 V maximum)
- Minimal loading of 0.5 pF at 20 k Ω to ground
- Operation in normal or inverted polarity is acceptable
- Any common mode voltage is acceptable so long as the maximum positive voltage does not exceed +5 V and the maximum negative voltage does not exceed -2.5 V

NOTE. You can find more information about the P6980 probe routing and pinout in the Signal Routing section. (See Figure 27 on page 32.)

P6982 High-Density Differential Probe

The P6982 Probe is a 17-channel, high-density connectorless differential probe with D-Max probing technology. (See Figure 6.) The probe consists of one probe head of 17 differential channels (16 data and 1 clock/qual).

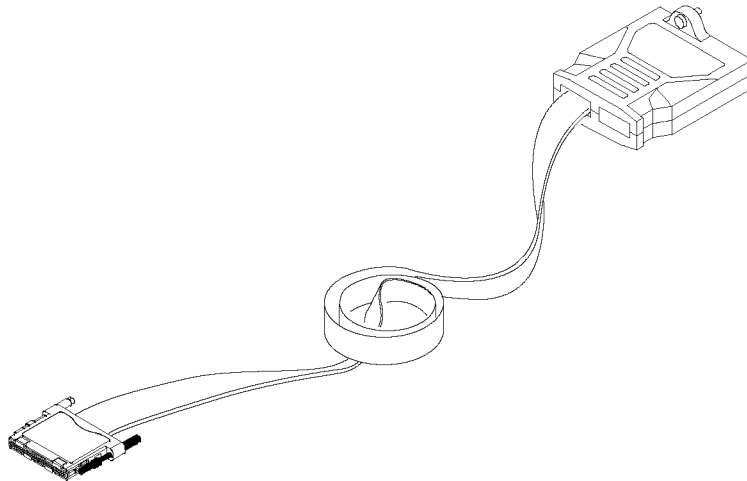

Figure 6: P6982 High-Density Differential probe with D-Max probing technology

The following list details the capabilities and qualities of the P6982 Probe:

- Differential data, clock and qualification inputs (single-ended signals may be probed if negative input is grounded)
- cLGA contact eliminates the need for a built-in connector
- Footprint supports direct signal pass-through
- Supports PCB thickness of 1.27 mm to 6.35 mm (0.050 in to 0.250 in)

- Consists of one probe head supporting 17 channels
- Optimized for 2X mode (1:2 demultiplexing) to minimize required board real estate
- Color-coded keyed attachment
- -2.5 V to +5 V input operating range
- -2.0 V to +4.5 V threshold range
- 300 mV minimum single-ended signal amplitude (5 V maximum)
- 150 mV each side minimum differential signal amplitude (2.5 V maximum)
- Minimal loading of 0.5 pF at 20 k Ω to ground
- Operation in normal or inverted polarity is acceptable
- Any common mode voltage is acceptable so long as the maximum positive voltage does not exceed +5 V and the maximum negative voltage does not exceed -2.5 V

NOTE. *You can find more information about the P6982 probe routing and pinout in the Signal Routing section. (See Figure 27 on page 32.)*

Connect the probes to the logic analyzer

Connect the probes to the logic analyzer according to the following steps. (See Figure 7.)

1. Identify the beveled edges of the connector inside the module end of the probe.
2. Align the beveled edges of the connector to its mating connector on the logic analyzer module and press into place.
3. Use care to evenly tighten both screws on the module end of the probe until they are snug. First slightly tighten both screws, then snug each screw to 4 in-lbs (max).

NOTE. All P6900 series Logic Analyzer probes can be connected to the logic analyzer when it is powered on. In addition, all P6900 series Logic Analyzer probes connect to the logic analyzer in exactly the same manner.

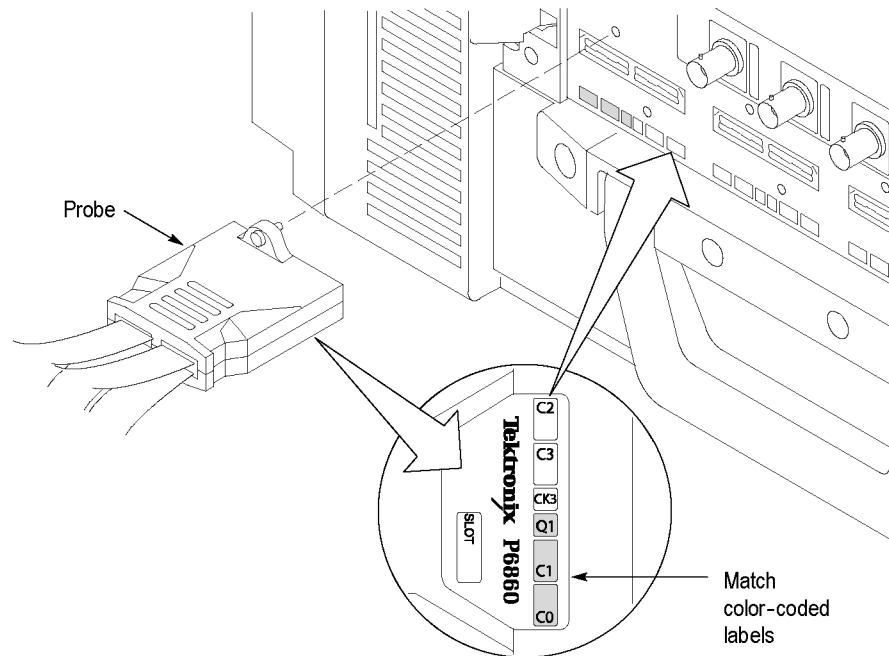

Figure 7: Connecting the probes to the logic analyzer

Connect the probes to the target system

You can connect the P6900 Series Probes to the target system without turning off the power to the target system. The target system must have either the probe retention posts or the alternate retention assembly installed. Installation procedures for both methods are described here.

Retention posts

The retention posts are mounted on a plastic carrier for easy installation to your circuit board. Two lengths of wires are shipped with the posts to allow use with thicker PCBs.

Use the correct retention post wires

If the PCB is $\leq .120$ in thick, use the wire that comes preattached to the posts. If the PCB is $> .120$ in thick, use the longer wire that is included with the posts.

The longer wires are embedded in the protective foam of the retention post kit. Make sure that you use the longer wires included in the kit when the PCB is $> .120$ in thick. Install the longer wires on the retention posts according to the following steps. (See Figure 8.)

1. Remove the old wire by pulling the side of the wire over the retaining tab and lifting the wire away from the post.
2. Place the new wire in the slot side without the tab, and then wrap the wire over the tab side until it engages in the slot (you will feel or hear a slight click).

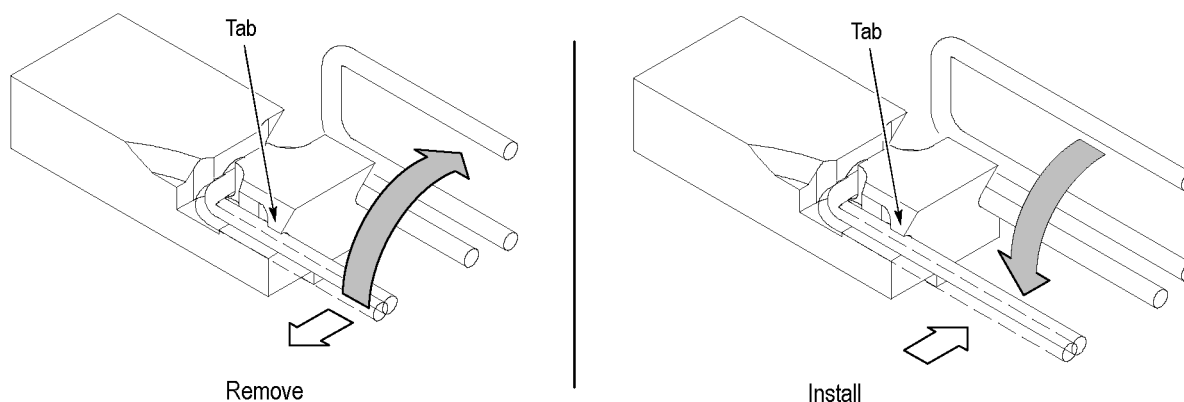

Figure 8: Replacing the wires on the retention posts

Install the retention posts

To install the retention posts on the PCB, do the following:

1. On the retention post/carrier assembly, locate the black retention post (the post with the keying pin) and align it to the keying pin hole on the PCB. (See Figure 9.)
2. Press the retention posts into the holes on the footprint on the PCB.

NOTE. *The following two steps – bending and soldering the wires to the circuit board – are the two most important steps in assuring that the probe retaining posts are correctly mounted. Bending the wires before soldering them helps prevent long-term cold solder flow.*

3. Press down on the carrier and bend the post wires out to anchor the posts to the PCB. Ensure the assembly is perpendicular to the PCB when bending and soldering the post wires.

The bend point in the retaining wire should be as close to the circuit board surface as possible. Grip the wire with a pair of needle-nose pliers about 1/8-inch above the circuit board surface and let the side of the through-hole (not the pliers) act as the fulcrum point for bending the wire. This method pulls the probe mounting posts tightly against the circuit board surface.

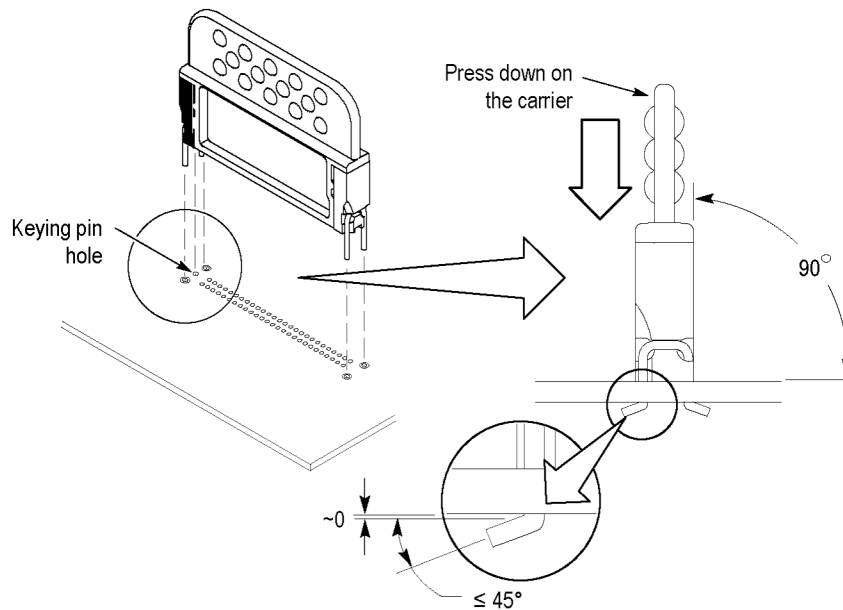

Figure 9: Installing the retention posts in the PCB

- Solder the posts to the PCB. (See Figure 10 on page 13.) The posts can be soldered from the top or bottom of the circuit board, but it is best to solder the bottom to avoid the heat-sinking effects of the posts on top.

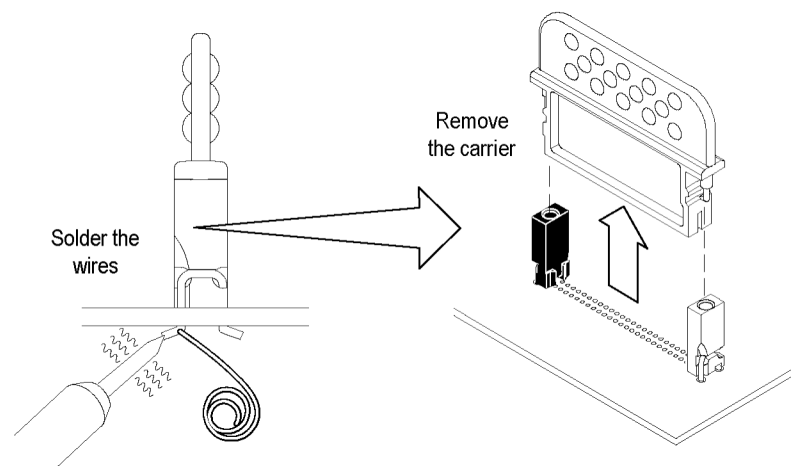

Figure 10: Soldering the retention posts in the PCB

- Pull off the carrier from the posts.

NOTE. The posts may have a small amount of movement after you solder them to the circuit board. This is normal and accounted for in the post design.

The probe should mate firmly to the board when the two screws are tightened to the mounting posts. The screws have a mechanical stop on them to prevent over-tightening the probe to the board.

After a probe has been installed and removed, there may be slightly more play in the posts. This is also normal and accounted for in the probe design.

Clean the compression footprints



CAUTION. To avoid electrical damage, always power off your target system before cleaning the compression footprint.

Before you connect the probe to the target system, clean the compression footprints on the board, according to the following steps:

- Use a lint-free, clean-room cloth lightly moistened with electronic/reagent grade isopropyl alcohol, and gently wipe the footprint surface.
- Remove any remaining lint using a nitrogen air gun or clean, oil-free dry air.

Alternate retention assembly

The alternate retention assembly provides a housing around the connector footprint to help stabilize the probe. Install the alternate retention assembly on the circuit board according to the following steps. (See Figure 11.)

1. Locate the correct footprint. If you intend to use multiple probes, your PCB has multiple footprints. Be careful to select the correct one.
2. Clean the compression footprint as described above.
3. Align the retention assembly over the footprint so that the keying pin on the retention assembly lines up with the keying pin hole on the footprint.
4. Insert the retention assembly into the holes in the footprint on the PCB.

NOTE. *The following two steps are important to ensure that the retention assembly is correctly mounted and that the probe makes proper contact with the PCB.*

5. Hold the retention assembly so that it is firmly flush with the surface of the footprint, and the four anchoring posts extend through the circuit board to the opposite side.
6. Using a pair of needle-nose pliers, grasp one of the posts. Using the circuit board hole as a fulcrum, bend the post outward so that it is flush with the PCB surface, anchoring the assembly to the PCB. Bend the other three posts in the same manner.
7. Solder the anchoring posts to the PCB.

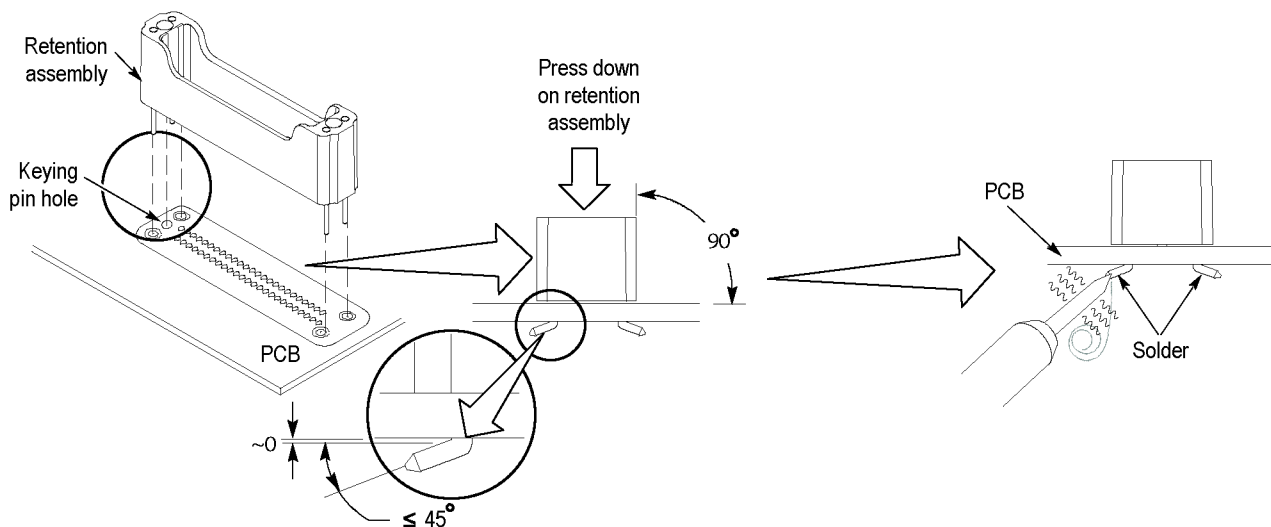

Figure 11: Installing the alternate retention assembly

Handling the cLGA Interface Clips (probe heads)

Always handle the cLGA interface clips in the probe heads with care. Keep the following points in mind when you handle the clips:

- Always handle the cLGA interface clips by the outer edges, being careful to avoid the contacts in the center. Do not touch the contacts with fingers, tools, wipes, or any other devices. (See Figure 12.)

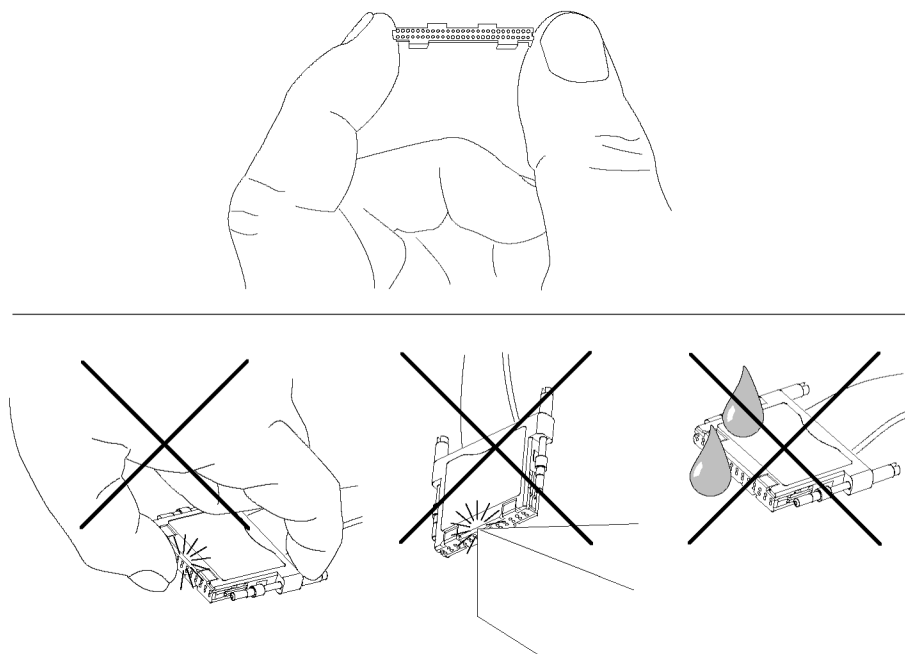

Figure 12: Proper handling of the interface clip

- Do not expose the connector to liquids or dry chemicals.
- If the board pad array needs to be cleaned, only use isopropyl alcohol and lint-free cloth as described above.
- Immediately following cleaning, or immediately prior to placement of connector to circuit board, the board pad array and connector contact array should be blown off with clean, oil-free dry air or nitrogen to remove loose debris. First start the blowing process by aiming away from the array areas, and then sweep across the pad and contact arrays in a repeated motion to remove loose debris.
- Place the connector onto the board pad array using the bosses or locator pins for alignment. Take care to prevent incidental contact with other surfaces or edges in the connector contact array area prior to board placement.
- Always store the probe head in the protective cover when not in use. (See Figure 16 on page 20.)

Connect the probe

Connect the probes using the following steps. (See Figure 13.)

1. Align the black screw on the probe to the black post on the PCB. If you are connecting the probe to the alternate retention assembly, align the silver screw on the probe to the silver side of the retention assembly.

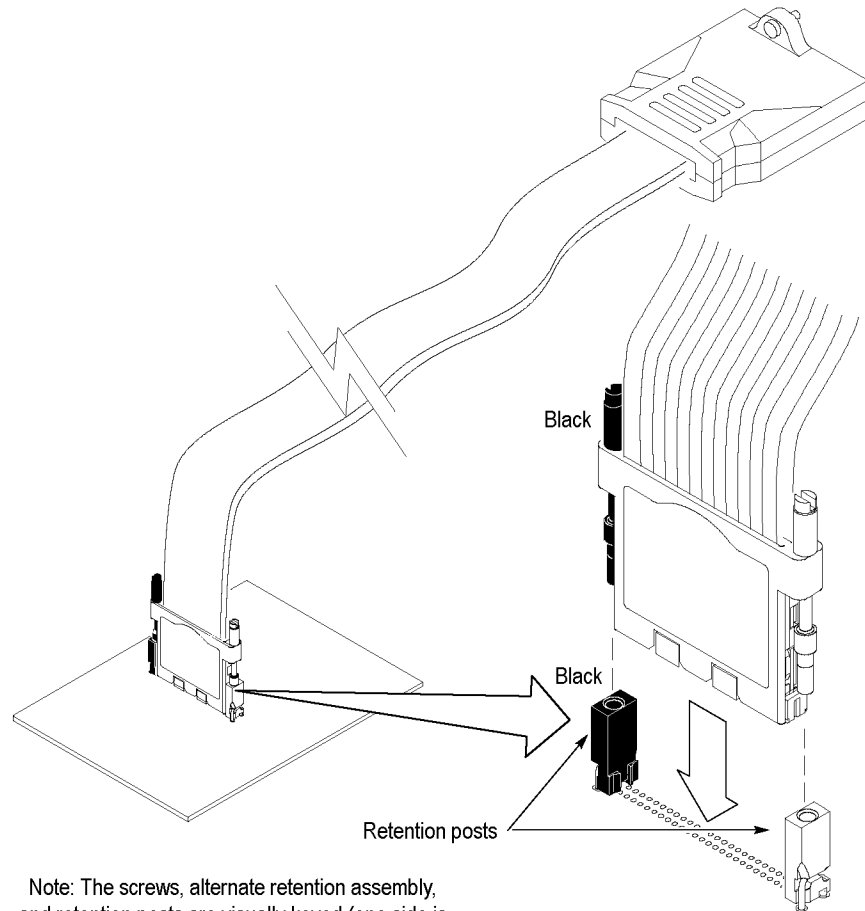

Note: The screws, alternate retention assembly, and retention posts are visually keyed (one side is black and one side is silver).

Figure 13: Connecting the probes to the target system

2. Start both screws in the posts, and tighten them evenly to ensure that the probe approaches and mates squarely to the PCB. If access is limited, use the adjustment tool that came with your probe. The probe is completely fastened to the PCB when the screws stop in the posts.
3. Verify that all of the channels are functional. You can find more information on any channel that appears to be nonfunctional in the following section. (See page 17, *Troubleshoot the probe connections to the DUT.*)

Troubleshoot the probe connections to the DUT

The most obvious symptom of a problem with the mounting post installation is seeing incorrect data in the logic analyzer acquisition. However, the nature of the incorrect data has a very consistent characteristic; the data from multiple channels go to a logic low and stay there. Intermittent bad data, or a single dead channel are not failures typically associated with probe mounting post installation problems.

1. Slightly move the probe head to either side, or press down on the probe head while making new acquisitions. If good data is now being acquired, then the probe mounting is most likely the cause.
2. If good data is not acquired, then remove the probe and check the posts for too much play. If there is significant play, then the probe mounting is most likely the cause.
3. If the posts have minimal play and you cannot see a gap between the bottom of the posts and the circuit board surface, then move the probe with bad data from one logic analyzer probe location to another.
4. If the problem follows the probe, then the probe is the problem. Visually inspect the cLGA interface clip on the probe for any damage or missing c-spring metal contacts.

If there is damage to the interface clip, or if any c-spring metal contacts are missing, replace the cLGA interface clip. (See page 56, *Replace the cLGA Clip.*)

5. If the problem does not follow the probe, it is either the logic analyzer or the probe connection at its previous location. Move the probe back to the original location to be certain that it was not a connection problem at the logic analyzer end.
6. Place another probe in the mounting posts of the original probe. If the new probe acquires data, then the old probe is probably at fault.

Connect the flying lead set

The flying lead set, Tektronix part number 196-3494-xx, is an optional accessory for your probe. The flying lead set allows you to connect to individual test points on your PCB. However, for general-purpose probing, the P6810 probe is recommended for best performance.

Connect the probe to the target system by performing the steps that follow. (See Figure 14.) You can connect the probe leads to the target system without turning off the power to the target system.

1. Connect the probe leads to the square pins on the PCB.
2. Connect the negative input to ground on the PCB.
3. Connect the leadset to the probe.

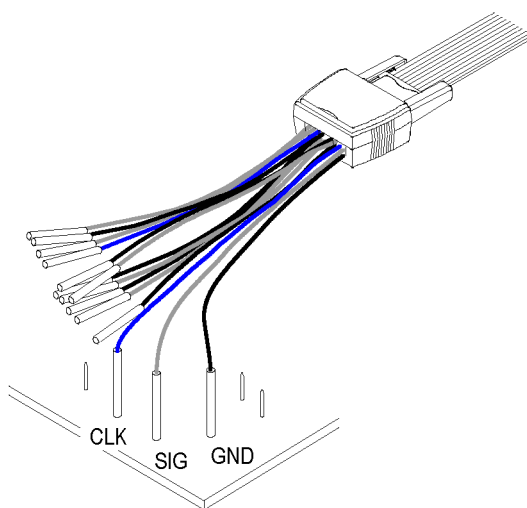

Figure 14: Using the flying lead set to connect to the target system

Dress the probe cables

Use the Velcro cable managers to combine the cables together or to help relieve strain on the probe connections.

Hang the probe cables so that you relieve the tension on the probes at the retention posts. (See Figure 15.)

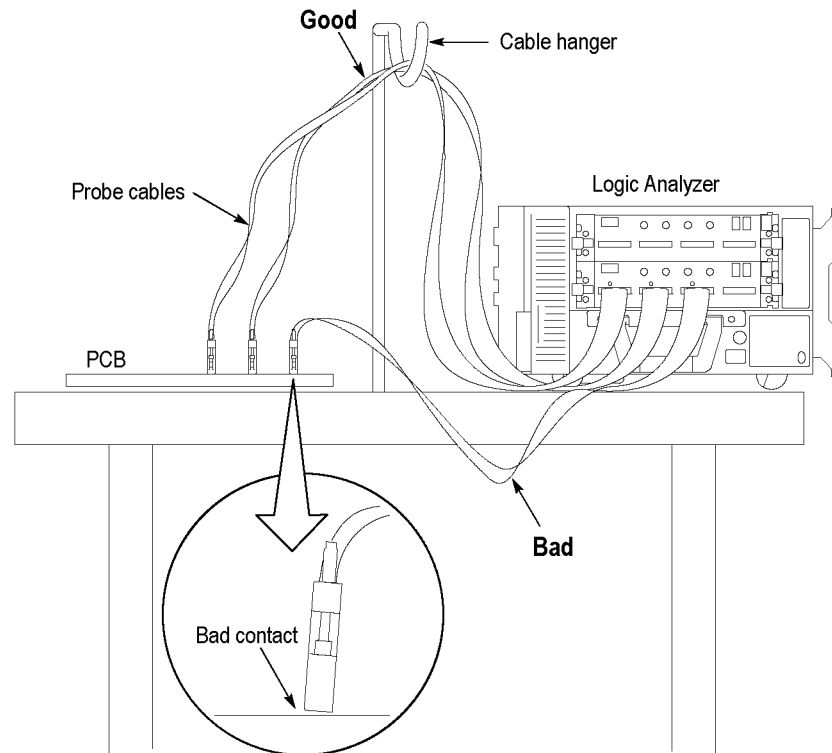

Figure 15: Proper dressing of the probe cables

Store the probe heads

To protect the interface clip, it is important to properly store the probe heads when the probes are not in use. (See Figure 16.)

Gently slide the probe cover over the probe end and store the probe.

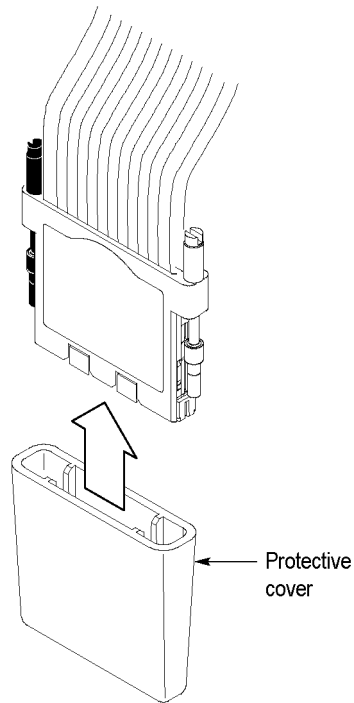

Figure 16: Protecting the probe heads

Reference

This section provides reference information for the P6900 Series High-Density Probes with D-Max probing technology.

Probe and target system interface design information

Once you have determined which probe is required, use the following information to design the appropriate connector into your target system board. The following topics are in this section:

- Signal fixturing considerations
- Signal connections (signal names and footprints)
- Mechanical considerations
- Electrical considerations

Signal fixturing considerations

This section contains the following information to consider for signal fixturing:

- Clocks and qualifiers
- Merged modules and source synchronous clocking
- Demultiplexing multiplexed buses
- 2X and 4X high resolution timing modes (Internal 2X and 4X)
- Probing analog signals
- Range recognition

Clocks and qualifiers. Every logic analyzer has some special purpose input channels. Inputs designated as clocks can cause the analyzer to store data. Qualifier channels can be logically ANDed and ORed with clocks to further define when the analyzer should latch data from the system under test. Routing the appropriate signals from your design to these inputs ensures that the logic analyzer can acquire data correctly. Unused clocks can be used as qualifier signals.

Depending on the channel width, each TLA7ACx Series logic analyzer module will have a different set of clock and qualifier channels. The following table shows the clock and qualifier channel availability for each module. (See Table 1 on page 22.)

Table 1: Logic analyzer clock and qualifier availability

TLA7ACx Module	Clock Inputs				Qualifier Inputs			
	CLK:0	CLK:1	CLK:2	CLK:3	QUAL:0	QUAL:1	QUAL:2	QUAL:3
TLA7AC2	✓	✓	✓	✓				
TLA7AC3	✓	✓	✓	✓	✓	✓		
TLA7AC4	✓	✓	✓	✓	✓	✓	✓	✓

All clock and qualifier channels are stored. The analyzer always stores the logic state of these channels every time it latches data.

Since clock and qualifier channels are stored in the analyzer memory, there is no need to double probe these signals for timing analysis. When switching from state to timing analysis modes, all of the clock and qualifier signals will be visible. This allows you to route signals not needed for clocking to the unused clock and qualifier channels.

It is a good practice to take advantage of the unused clock and qualifier channels to increase your options for when you will latch data. Routing several clocks and strobes in your design to the analyzer clock inputs will provide you with a greater flexibility in the logic analyzer clocking setup menus.

As an example, look at a microprocessor with a master clock, data strobe, and an address strobe. Routing all three of these signals to analyzer clock inputs will enable you to latch data on the processor master clock, only when data is strobed, or only when address is strobed. Some forethought in signal routing can greatly expand the ways in which you can latch and analyze data.

A microprocessor also provides a good example of signals that can be useful as qualifiers. There are often signals that indicate data reads versus data writes (R/W), signals that show when alternate bus masters have control of the processor buses (DMA), and signals that show when various memory devices are being used (ChipSel). All of these signals are good candidates for assignment to qualifier channels.

By logically ANDing the clock with one of these qualifiers you can program the analyzer to store only data reads or data writes. Using the DMA signal as a qualifier provides a means of filtering out alternate bus master cycles. Chip selects can limit data latching to specific memory banks, I/O ports, or peripheral devices.

Merged module sets and source synchronous clocking. TLA7ACx analyzer modules that are 102-channels or 136-channels wide can be merged together to act as a single logic analyzer with a larger channel count. Up to five modules can be merged to provide up to a 680-channel analyzer. A unique feature of the TLA7ACx module is that it supports source synchronous clocking. Combining these two capabilities provide some additional considerations for signal routing.

Source synchronous clocking is a method that manages the skew between the system clock and the data bus by requiring the sending device to drive an actual clock or strobe signal along with the data that is very tightly coupled with it in terms of skew. The receiving device then uses this strobe to capture the data.

A variant of this scheme is being applied to large microprocessor buses, where the bus is split into smaller, more easily managed groups that each have their own dedicated strobe. Although the timing relationship between a particular clock and its associated data group is very tight, the timing between the different groups can vary greatly and changes depending on which device has control of the bus.

Many source synchronous designs use wide buses. It is not uncommon to require a set of merged logic analyzer modules to provide the channel count needed in probing larger source synchronous systems. While all of the modules in a merged set can use their clock inputs independently if needed, remember that there are a maximum of four clock inputs on a 136-channel wide module.

To see the importance of this we will once again use a microprocessor system as an example. Tektronix logic analyzer processor has a 32-bit address bus and a 64-bit data bus. The data bus is split into four 16-bit subgroups that have independent source synchronous clocks. For the logic analyzer to correctly acquire data from this system it will need five clock inputs, one for the address bus and one each for the four 16-bit data bus subgroups.

To acquire both buses, the analyzer would need at least 96 channels (32 address and 64 data). However, a single 102 channel card does not have the required five clock inputs. By merging two 102-channel modules into a set you can obtain the needed number of clock inputs. Route the address bus to one module in the set and route the data bus, along with its four source synchronous clocks, to the second module in the set.

Demultiplexing multiplexed buses. TLA7ACx modules support both 2X and 4X demultiplexing. TLA7NAX modules support 2X demultiplexing. Each signal on a dual or quad multiplexed bus can be demultiplexed into its own logic analyzer channel. Refer to the following tables to determine the correct channel groups to use.

Table 2: 2X Demultiplexing source-to-destination channel assignments

Source	Destination channels receiving target system test data					
	TLA7AC4/ TLA7NA4	TLA7AC3/ TLA7NA3	TLA7AC2 /TLA7NA2	TLA7AA1/ TLA7NA1	TLA7AB4	TLA7AB2
A3:7-0	D3:7-0	D3:7-0	C3:7-0	C3:7-0	D3:7-0	C3:7-0
A2:7-0	D2:7-0	D2:7-0	C2:7-0	C2:7-0	D2:7-0	C2:7-0
A1:7-0	D1:7-0	D1:7-0	D1:7-0	—	D1:7-0	D1:7-0
A0:7-0	D0:7-0	D0:7-0	D0:7-0	—	D0:7-0	D0:7-0
C3:7-0	C1:7-0	C1:7-0	—	—	C1:7-0	—
C2:7-0	C0:7-0	C0:7-0	—	—	C0:7-0	—
E3:7-0	E1:7-0	—	—	—	E1:7-0	—
E2:7-0	E0:7-0	—	—	—	E0:7-0	—
CLK:0	QUAL:1	QUAL:1	—	—	QUAL:1	—
CLK:1	QUAL:0	QUAL:0	—	—	QUAL:0	—
CLK:2	QUAL:3	—	—	—	QUAL:3	—
CLK:3	QUAL:2	—	—	—	QUAL:2	—

Table 3: 4X Demultiplexing source-to-destination channel assignments

Source	Destination channels receiving target system test data					
	TLA7AA4	TLA7AA3	TLA7AA2	TLA7AA1	TLA7AB4	TLA7AB2
C3:7-0	C2:7-0	C2:7-0	A3:7-0 A2:7-0	A3:7-0 A2:7-0	C2:7-0	A3:7-0 A2:7-0
	C1:7-0	C1:7-0	C2:7-0	C2:7-0	C1:7-0	C2:7-0
	C0:7-0	C0:7-0			C0:7-0	
A1:7-0	A0:7-0	A0:7-0	A0:7-0	—	A0:7-0	A0:7-0
	D1:7-0	D1:7-0	D1:7-0		D1:7-0	D1:7-0
	D0:7-0	D0:7-0	D0:7-0		D0:7-0	D0:7-0
A3:7-0	A2:7-0	A2:7-0	—	—	A2:7-0	—
	D3:7-0	D3:7-0			D3:7-0	
	D2:7-0	D2:7-0			D2:7-0	
E3:7-0	E2:7-0	—	—	—	E2:7-0	—
	E1:7-0				E1:7-0	
	E0:7-0				E0:7-0	
CLK:3	CLK:2	—	—	—	CLK:2	—
	QUAL:3				QUAL:3	
	QUAL:2				QUAL:2	
CLK:1	CLK:0	CLK:0	—	—	CLK:0	—
	QUAL:1	QUAL:1			QUAL:1	
	QUAL:0	QUAL:0			QUAL:0	

When demultiplexing data there is no need to connect the destination channels to the multiplexed bus. Data from the source channels are routed to the destination channels internal to the logic analyzer. You can find more information about the mapping of source channels to destination channels in the *Demultiplexing Multiplexed Buses* section. (See page 24.)

Demultiplexing affects only the main memory for the destination channels. This means that the MagniVu memory is filled with data from whatever is connected to the demultiplexing destination channel probe inputs. This provides an opportunity to acquire high resolution MagniVu data on a few extra channels. Connecting the demultiplexing destination channels to other signals will allow viewing of their activity in the MagniVu memory but not the main memory.

2X and 4X high resolution timing modes. The 2X high resolution timing mode provides double the normal 500 MHz sample rate on one-half of the channels. By trading half of the analyzer's channels, the remaining channels can be sampled at a 1 GHz rate with double the memory depth. Likewise, 4X high resolution timing mode provides quadruple the normal 500 MHz sample rate on one-fourth of the channels. By trading three-fourths of the analyzer's channels, the remaining channels can be sampled at a 2 GHz rate with quadruple the memory depth.

Both of the high resolution timing modes use the same demultiplexing channel routing. (See Table 2.) (See Table 3.) By taking care to assign critical signals to the demultiplexing source channels, you can obtain extra timing resolution where it is most needed. Since demultiplexing affects only the main memory you will still have the MagniVu data available for all of the signals that are disconnected from the main memory when you switch to the high resolution timing modes.

Analog signals probing. The TLA7ACx module provides visibility of analog signals with Analog mux. Analog mux routes the actual signal seen by each channel's probe through a high bandwidth path to an analog multiplexer inside of the logic analyzer module. From the logic analyzer interface, you can route any input channel to one of four output connectors on the module. By connecting the analyzer analog outputs to your oscilloscope, you can see the analog characteristics of any signal probed by the logic analyzer.

Sometimes it is convenient to have analog signals accessible for easier probing. Signals such as A/D Converter inputs, D/A Converter outputs, low voltage power supplies, termination voltages, and oscillator outputs are just a few examples. Routing these signals to unused logic analyzer inputs provides a quick method of viewing their activity without ever picking up an oscilloscope probe.

Take care to ensure that such signals are voltage limited and will not exceed the maximum nondestructive input voltage for the logic analyzer probes of ± 15 V_{peak}.

Range recognition. When using range recognizers, the probe groups and probe channels must be in hardware order. Probe groups must be used from the most-significant probe group to the least-significant probe group based on the following order:

C3 C2 C1 C0 E3 E2 E1 E0 A3 A2 D3 D2 A1 A0 D1 D0 Q3 Q2 Q1 Q0 CK3
CK2 CK1 CK0

Probe channels must be from the most-significant channel to the least-significant channel based on the following order:

7 6 5 4 3 2 1 0

The above examples assumes a 136-channel LA module. The missing channels in LA modules with fewer than 136 channels are ignored. With merged modules, range recognition extends across the first three modules: the master module contains the most-significant channels.

Board design

This section provides information that helps you design your PCB mechanically and electrically for use with the P6900 Series Probes.

Probe dimensions The following figures show the dimensions for the P6960, P6960HS, P6980, and P6982 probes.

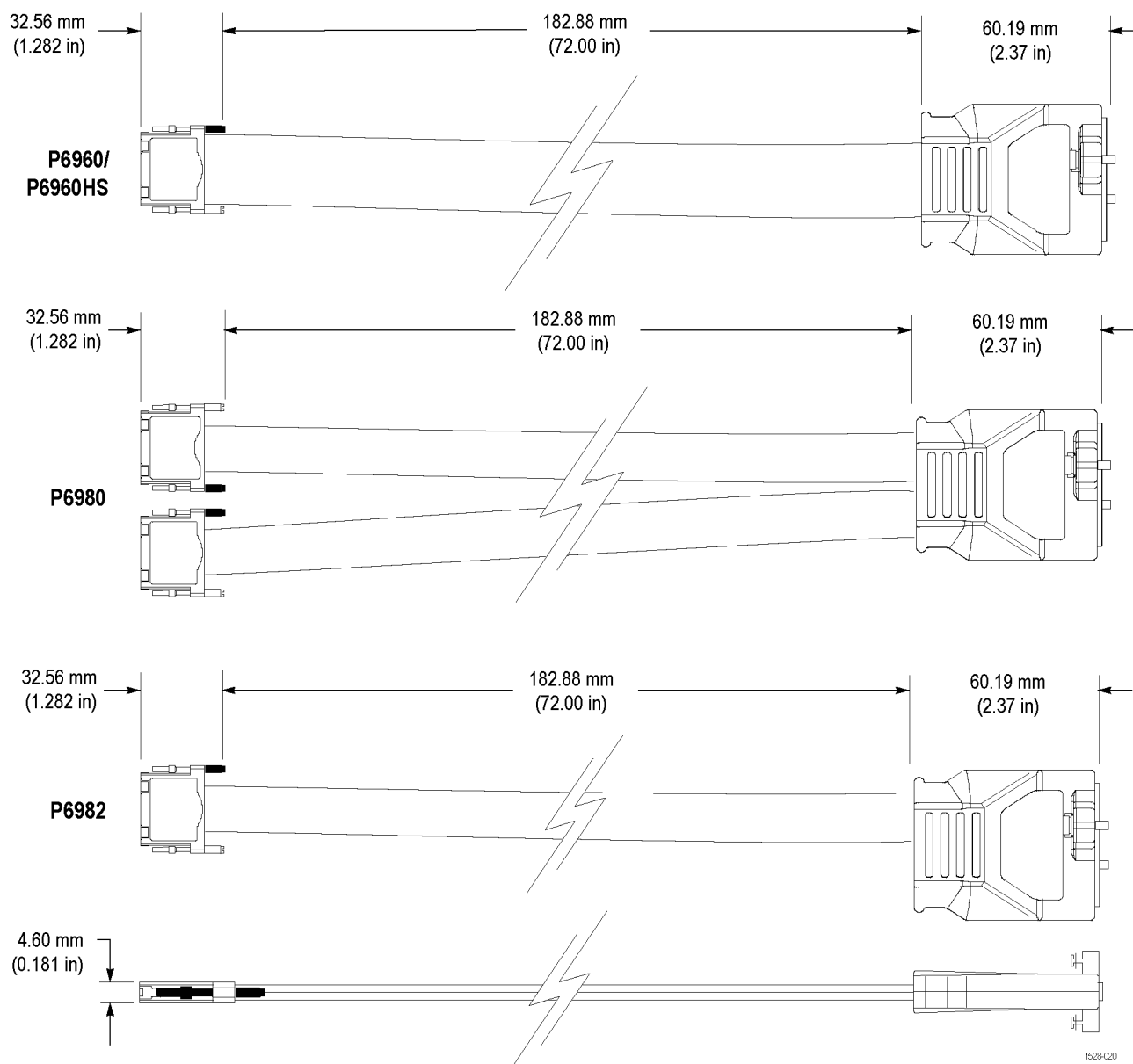

Figure 17: P6960, P6960HS, P6980, and P6982 probe dimensions

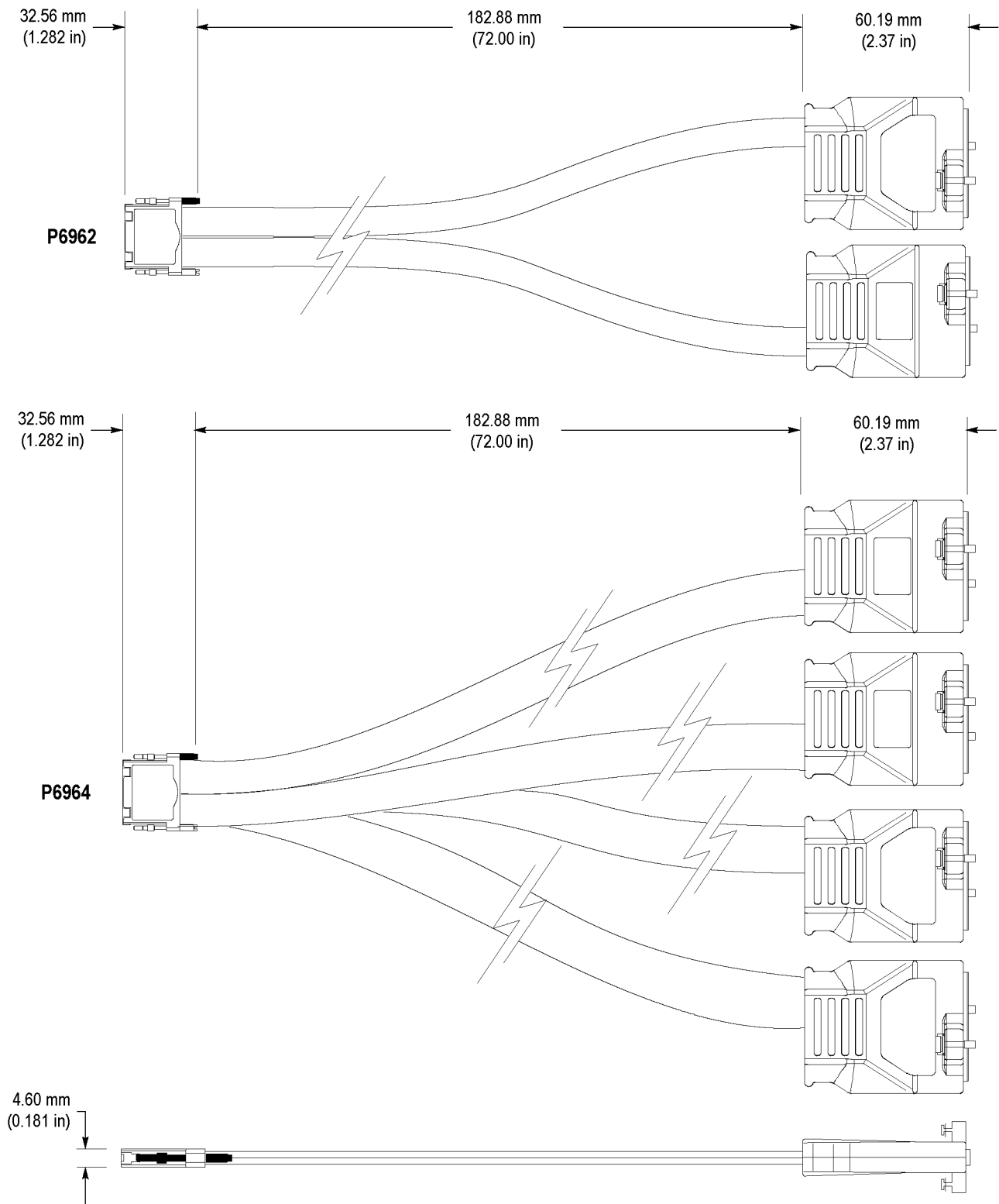

Figure 18: P6962 and P6964 probe dimensions

Retention post dimensions and keepout area

You can attach the probes to the PC board using two retention posts. (See Figure 19.) You can alternately attach the probes to the PC board retention assembly. (See Figure 23 on page 30.)

Both mounting methods hold the probe securely to the board, and ensure a reliable electrical and mechanical connection and pin-to-pad alignment to your design. Board thicknesses that are supported include 1.27 mm (0.050 in) to 6.35 mm (0.250 in). The dimensions of the retention posts are shown in the following figure. (See Figure 19.)

All dimensions are per standard IPC tolerance, which is ± 0.004 in.



CAUTION. To avoid solder creep, bend the post wires out after you insert the posts in the board, and then solder the post wires. You can solder the retention wires from the top or bottom of the circuit board.

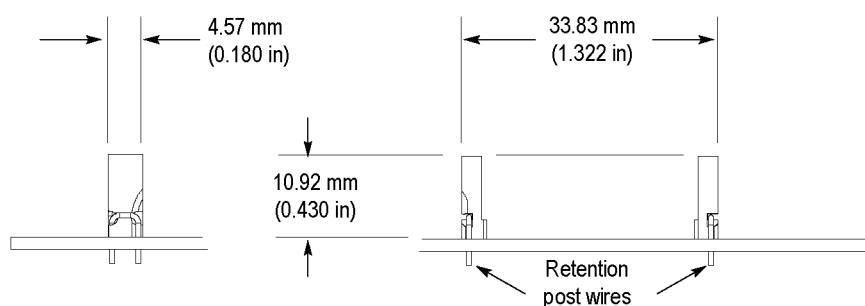

Figure 19: Retention post dimensions

The following figure shows the keepout area required for the retention posts. (See Figure 20.) Vias must be placed outside of the keepout area. Any traces routed on the top layer of the board must stay outside of the keepout area. Traces may be routed on inner layers of the board through the keepout area.

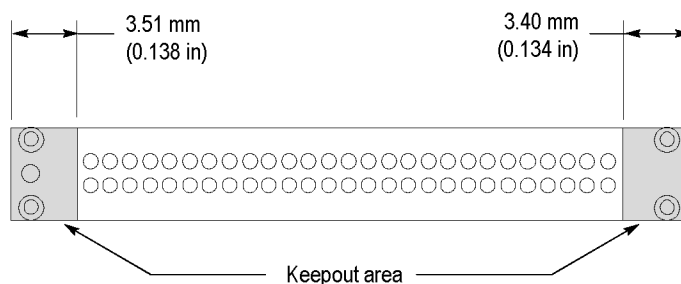

Figure 20: Keepout area

Side-by-side and end-to-end layout dimensions

The following figure shows the dimensions for side-by-side footprint layout. (See Figure 21.)

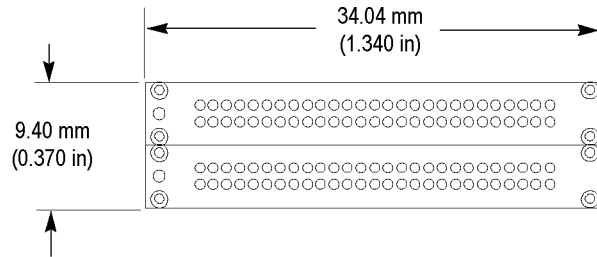

Figure 21: Side-by-side layout

The following figure shows the dimensions for an end-to-end footprint layout. (See Figure 22.)

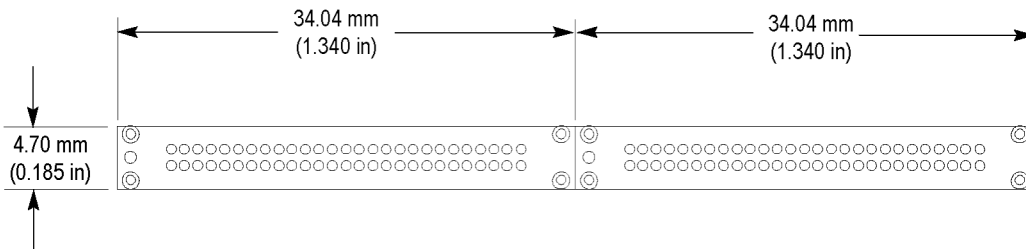

Figure 22: End-to-end layout

Alternate retention assembly dimensions and keepout area

The alternate retention assembly provides a housing around the connector footprint to help stabilize the probe. The following figure shows the dimensions of the assembly. (See Figure 23.)

All dimensions are per standard IPC tolerance, which is ± 0.004 in.



CAUTION. To avoid solder creep, bend the assembly wires out after you insert the wires in the board, and then solder the wires.

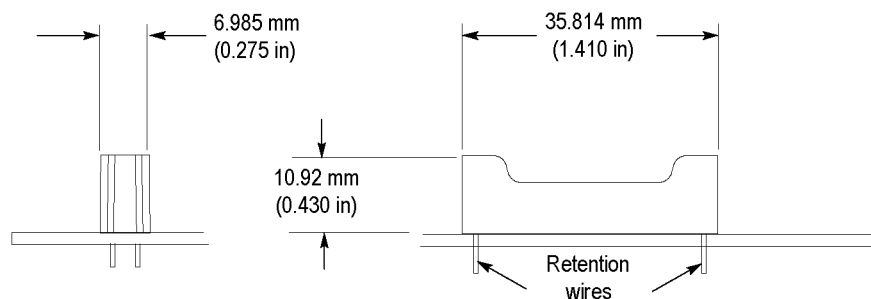

Figure 23: Alternate retention assembly dimensions

The following figure shows the keepout area required for the alternate retention assembly. (See Figure 24.)

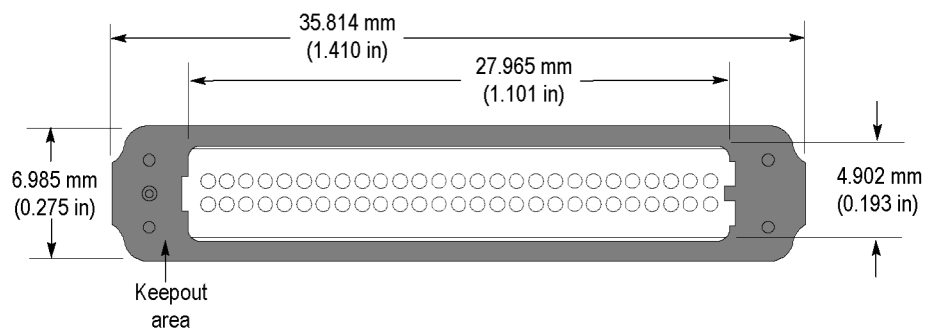

Figure 24: Keepout area



NOTE. Tektronix has provided a 3D CAD solid model file (named *dmax_socket_assembly.stp*) for the plastic retention assembly. It also includes footprint information for your circuit board. The file is attached to this PDF file. To access the attached file, open the PDF file and click on the paperclip icon on the left side of the document viewer.

Side-by-side and End-to-end layout dimensions

The following figure shows the dimensions for side-by-side footprint layout. (See Figure 25.)

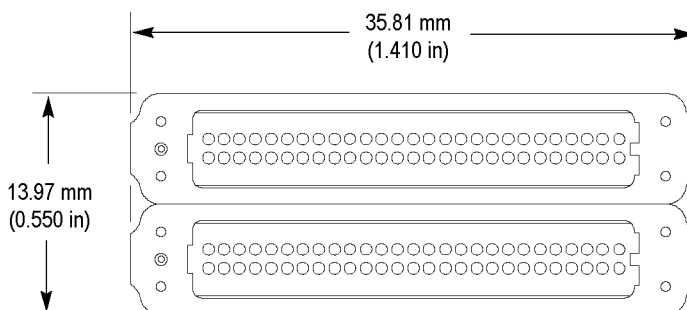

Figure 25: Side-by-side layout

The following figure shows the dimensions for an end-to-end footprint layout. (See Figure 26.)

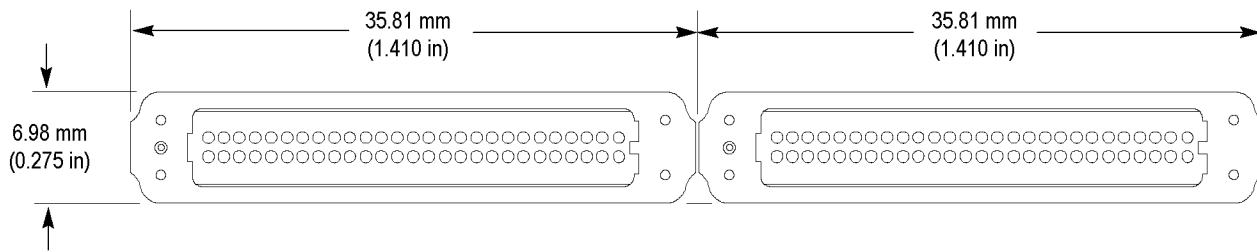

Figure 26: End-to-end layout

Signal routing

The following figure shows examples of pass-through signal routing for a single-ended data configuration and a differential data configuration. (See Figure 27.)

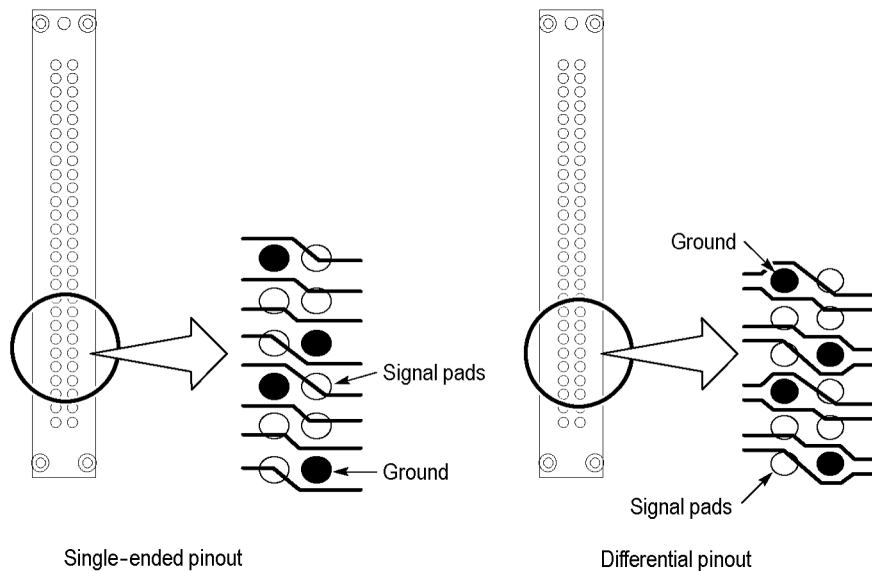

Figure 27: Signal routing on the target system

Mechanical considerations

This section provides information on compression footprint requirements and physical attachment requirements.

The PCB holes, in general, do not have an impact upon the integrity of your signals when the signals routed around the holes have the corresponding return current plane immediately below the signal trace for the entire signal path from driver to receiver.

NOTE. For optimum signal integrity, there should be a continuous, uninterrupted ground return plane along the entire signal path.

Physical attachment requirements for the P6900 Series Probes. The P6900 Series Probe interconnects are designed to accommodate PCB thickness ranging from 1.27 mm to 6.35 mm (0.050 in to 0.250 in). To accommodate this range, there are two wire lengths in the design:

- For board thicknesses of 0.050 in to 0.120 in, use the standard wire that comes mounted to the post in the retention kit included with each probe.
- For board thicknesses of 0.120 in to 0.250 in, use the long wire supplied with the probe (also included in the retention kit, embedded in foam).

(See page 11, *Use the correct retention post wires.*)

Electrical considerations

This section provides information on transmission lines and load models for the P6900 Series Probes.

The low-frequency model is typically adequate for rise and fall times of 1 ns or slower in a typical 25 Ω source impedance environment (50 Ω runs with a pass-through connection). For source impedance outside this range, and/or rise and fall times faster than 1 ns, use the high-frequency model to determine if a significant difference is obtained in the modeling result.

The compression land pattern pad is not part of the load model. Make sure that you include the compression land pad in the modeling.

Transmission lines. Due to the high performance nature of the interconnect, ensure that stubs, which are greater than 1/4 length of the signal rise time, are modeled as transmission lines.

P6900 Series probes load model. The following electrical model includes a low-frequency and high-frequency model of the High-Density Single-Ended and High-Density Differential Probes. (See Figure 28.) For the Differential Probes, the load model is applied to both the + side and the – side of the signal.

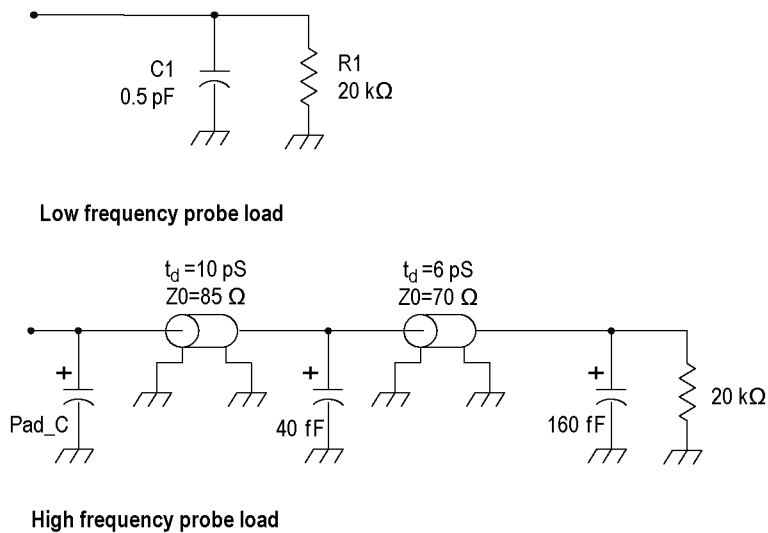

Figure 28: High-Density probe load model

The differential load for the P6960 and P6964 clock inputs and the P6980 and P6982 probes can be modeled by attaching the single line model to each side (+ and -) of the differential signal. The + and - sides of the differential signal are well insulated in the probe head up to and including the differential input stage.

Other design considerations

Via-in-pad Traditional layout techniques require vias to be located next to a pad and a signal routed to the pad, causing a stub and more PCB board area to be used for the connection. Many new digital designs require you to minimize the electrical effects of the logic analyzer probing that you design into the circuit board.

Using via-in-pad to route signals to the pads on the circuit board allows you to minimize the stub length of the signals on your board, thus providing the smallest intrusion to your signals. It also enables you to minimize the board area that is used for the probe footprint and maintain the best electrical performance of your design.

The following figure shows a footprint example where two pads use vias. (See Figure 30.) Detail A describes the recommended position of the via with respect to the pad.

All dimensions are per standard IPC tolerance, which is ± 0.004 in.

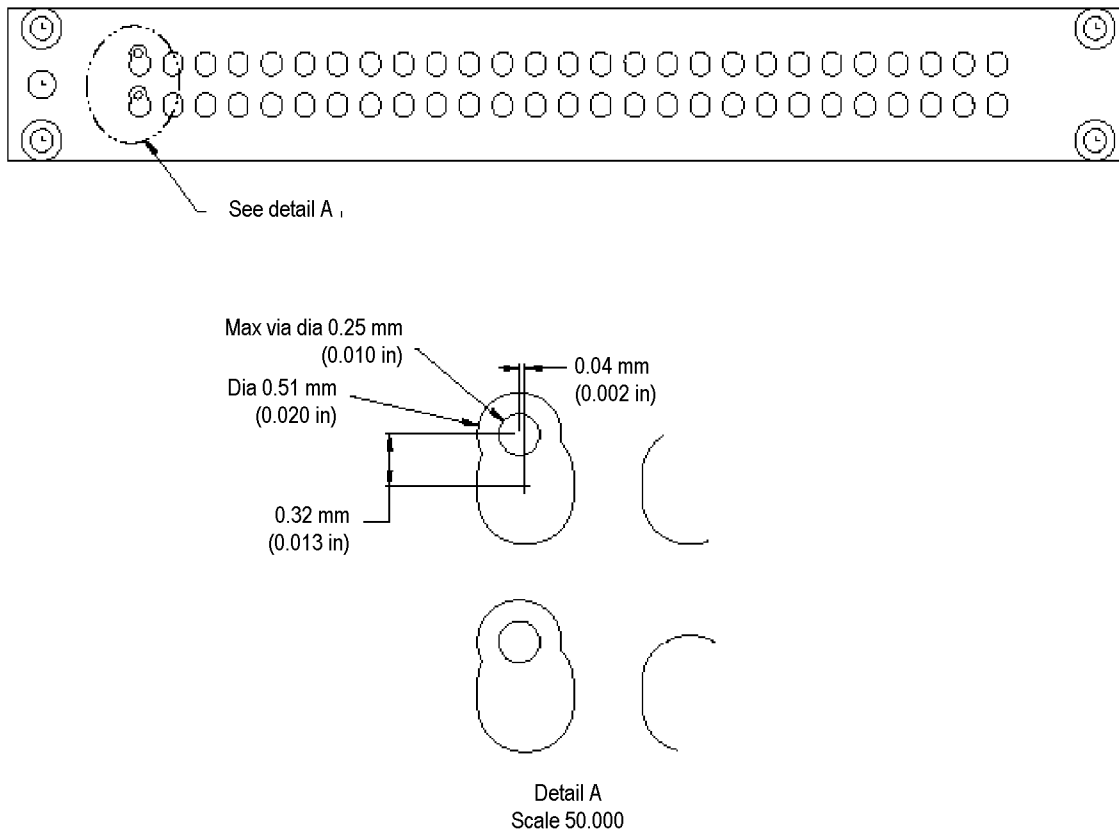

Figure 30: Optional Via-in-pad placement recommendation

Probe pinout definition and channel assignment

This section contains probe pinout definitions and channel assignment tables for the P6900 Series Probes.

P6960/P6960HS Single-ended probes with D-Max probing technology

The following figure shows the pad assignments, pad numbers, and signal names for the PCB footprint of the P6960/P6960HS single-ended data, differential clock logic analyzer probes. (See Figure 31.) The P6960/P6960HS probes have 32 data channels, one clock, and one qualifier for each footprint.

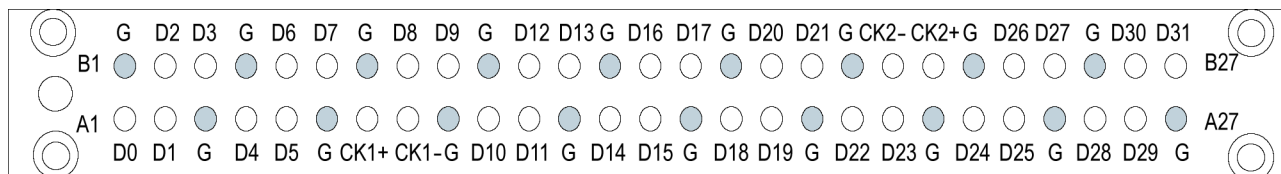

Figure 31: P6960/P6960HS single-ended PCB footprint pinout detail

The listing of channel mapping to a logic analyzer module for P6960/P6960HS single-ended data, differential clock logic analyzer probes is as follows. (See Table 4.)

Table 4: Channel assignment for P6960/P6960HS single-ended data, differential clock logic analyzer probes

Land pattern	Signal name	136-channel module only	136- and 102-channel modules			68-channel module only	68- and 34-channel modules
		Probe 4	Probe 3	Probe 2	Probe 1	Probe 2	Probe 1
A1	D0	E2:0	A2:0	A0:0	C2:0	A0:0	C2:0
A2	D1	E2:1	A2:1	A0:1	C2:1	A0:1	C2:1
A3	GND	GND	GND	GND	GND	GND	GND
A4	D4	E2:4	A2:4	A0:4	C2:4	A0:4	C2:4
A5	D5	E2:5	A2:5	A0:5	C2:5	A0:5	C2:5
A6	GND	GND	GND	GND	GND	GND	GND
A7	CK1+	Q3+	CK0+	CK1+	CK3+	CK1+	CK3+
A8	CK1-	Q3-	CK0-	CK1-	CK3-	CK1-	CK3-
A9	GND	GND	GND	GND	GND	GND	GND
A10	D10	E3:2	A3:2	A1:2	C3:2	A1:2	C3:2
A11	D11	E3:3	A3:3	A1:3	C3:3	A1:3	C3:3
A12	GND	GND	GND	GND	GND	GND	GND
A13	D14	E3:6	A3:6	A1:6	C3:6	A1:6	C3:6
A14	D15	E3:7	A3:7	A1:7	C3:7	A1:7	C3:7
A15	GND	GND	GND	GND	GND	GND	GND
A16	D18	E1:5	D3:5	D1:5	C1:5	D1:5	A3:5

Table 4: Channel assignment for P6960/P6960HS single-ended data, differential clock logic analyzer probes (cont.)

Land pattern		136-channel module only	136- and 102-channel modules				68-channel module only	68- and 34-channel modules
Pin number	Signal name	Probe 4	Probe 3	Probe 2	Probe 1	Probe 2	Probe 1	
A17	D19	E1:4	D3:4	D1:4	C1:4	D1:4	A3:4	
A18	GND	GND	GND	GND	GND	GND	GND	
A19	D22	E1:1	D3:1	D1:1	C1:1	D1:1	A3:1	
A20	D23	E1:0	D3:0	D1:0	C1:0	D1:0	A3:0	
A21	GND	GND	GND	GND	GND	GND	GND	
A22	D24	E0:7	D2:7	D0:7	C0:7	D0:7	A2:7	
A23	D25	E0:6	D2:6	D0:6	C0:6	D0:6	A2:6	
A24	GND	GND	GND	GND	GND	GND	GND	
A25	D28	E0:3	D2:3	D0:3	C0:3	D0:3	A2:3	
A26	D29	E0:2	D2:2	D0:2	C0:2	D0:2	A2:2	
A27	GND	GND	GND	GND	GND	GND	GND	
B1	GND	GND	GND	GND	GND	GND	GND	
B2	D2	E2:2	A2:2	A0:2	C2:2	A0:2	C2:2	
B3	D3	E2:3	A2:3	A0:3	C2:3	A0:3	C2:3	
B4	GND	GND	GND	GND	GND	GND	GND	
B5	D6	E2:6	A2:6	A0:6	C2:6	A0:6	C2:6	
B6	D7	E2:7	A2:7	A0:7	C2:7	A0:7	C2:7	
B7	GND	GND	GND	GND	GND	GND	GND	
B8	D8	E3:0	A3:0	A1:0	C3:0	A1:0	C3:0	
B9	D9	E3:1	A3:1	A1:1	C3:1	A1:1	C3:1	
B10	GND	GND	GND	GND	GND	GND	GND	
B11	D12	E3:4	A3:4	A1:4	C3:4	A1:4	C3:4	
B12	D13	E3:5	A3:5	A1:5	C3:5	A1:5	C3:5	
B13	GND	GND	GND	GND	GND	GND	GND	
B14	D16	E1:7	D3:7	D1:7	C1:7	D1:7	A3:7	
B15	D17	E1:6	D3:6	D1:6	C1:6	D1:6	A3:6	
B16	GND	GND	GND	GND	GND	GND	GND	
B17	D20	E1:3	D3:3	D1:3	C1:3	D1:3	A3:3	
B18	D21	E1:2	D3:2	D1:2	C1:2	D1:2	A3:2	
B19	GND	GND	GND	GND	GND	GND	GND	
B20	CK2-	Q2-	Q0-	CK2-	Q1-	CK2-	CK0-	
B21	CK2+	Q2+	Q0+	CK2+	Q1+	CK2+	CK0+	
B22	GND	GND	GND	GND	GND	GND	GND	

Table 4: Channel assignment for P6960/P6960HS single-ended data, differential clock logic analyzer probes (cont.)

Land pattern	Signal name	136-channel module only	136- and 102-channel modules			68-channel module only	68- and 34-channel modules
		Probe 4	Probe 3	Probe 2	Probe 1	Probe 2	Probe 1
B23	D26	E0:5	D2:5	D0:5	C0:5	D0:5	A2:5
B24	D27	E0:4	D2:4	D0:4	C0:4	D0:4	A2:4
B25	GND	GND	GND	GND	GND	GND	GND
B26	D30	E0:1	D2:1	D0:1	C0:1	D0:1	A2:1
B27	D31	E0:0	D2:0	D0:0	C0:0	D0:0	A2:0

P6962 single-ended probe with D-Max probing technology

The following figure shows the pad assignments, pad numbers, and signal names for the PCB footprint of the P6962 single-ended data, differential clock logic analyzer probe. (See Figure 31.) The P6962 probe has 32 data channels and two clocks for each footprint.

C2, C3 and E2, E3 group

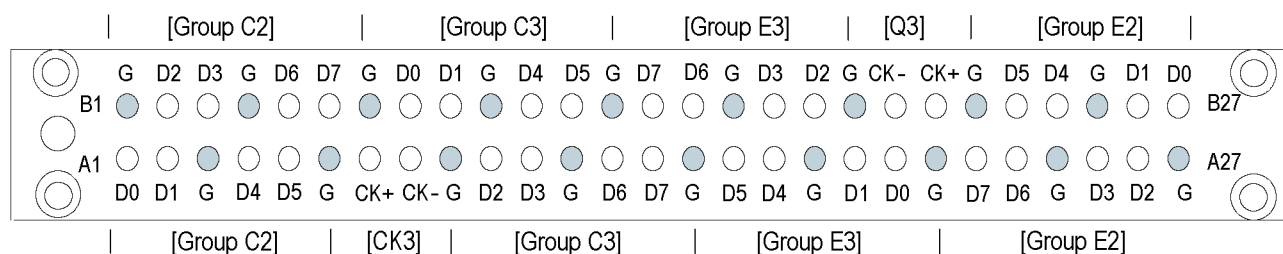

A0 - A3 group

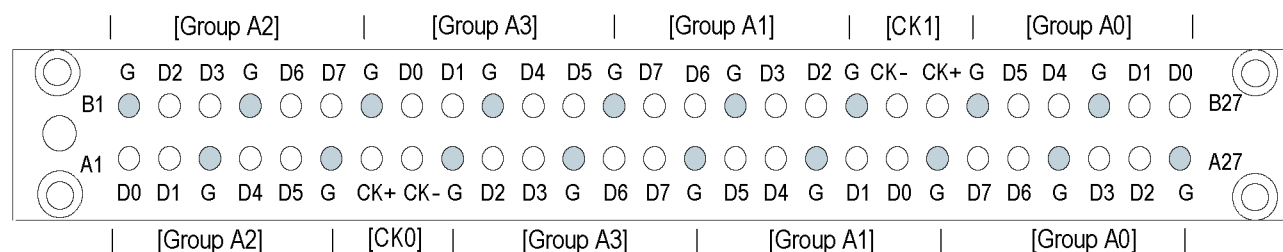

Figure 32: P6962 single-ended PCB footprint pinout detail

The following table lists the channel mapping to a logic analyzer module for a P6962 single-ended data, differential clock logic analyzer probe.

Table 5: Channel assignment for a P6962 single-ended data, differential clock logic analyzer probe

Pin number	C and E group probe	A0-A3 group probe
A1	C2:0	A2:0
A2	C2:1	A2:1
A3	GND	GND
A4	C2:4	A2:4
A5	C2:5	A2:5
A6	GND	GND
A7	CK+	CK+
A8	CK-	CK-
A9	GND	GND
A10	C3:2	A3:2
A11	C3:3	A3:3
A12	GND	GND
A13	C3:6	A3:6
A14	C3:7	A3:7
A15	GND	GND
A16	E3:5	A1:5
A17	E3:4	A1:4
A18	GND	GND
A19	E3:1	A1:1
A20	E3:0	A1:0
A21	GND	GND
A22	E2:7	A0:7
A23	E2:6	A0:6
A24	GND	GND
A25	E2:3	A0:3
A26	E2:2	A0:2
A27	GND	GND
B1	GND	GND
B2	C2:2	A2:2
B3	C2:3	A2:3
B4	GND	GND
B5	C2:6	A2:6
B6	C2:7	A2:7
B7	GND	GND

Table 5: Channel assignment for a P6962 single-ended data, differential clock logic analyzer probe (cont.)

Pin number	C and E group probe	A0-A3 group probe
B8	C3:0	A3:0
B9	C3:1	A3:1
B10	GND	GND
B11	C3:4	A3:4
B12	C3:5	A3:5
B13	GND	GND
B14	E3:7	A1:7
B15	E3:6	A1:6
B16	GND	GND
B17	E3:3	A1:3
B18	E3:2	A1:2
B19	GND	GND
B20	CK-	CK-
B21	CK+	CK+
B22	GND	GND
B23	E2:5	A0:5
B24	E2:4	A0:4
B25	GND	GND
B26	E2:1	A0:1
B27	E2:0	A0:0

P6964 single-ended probe with D-Max probing technology

The following figure shows the pad assignments, pad numbers, and signal names for the PCB footprint of the P6964 single-ended data, differential clock logic analyzer probe. (See Figure 33.) The P6964 probe has 32 data channels and two clocks for each footprint.

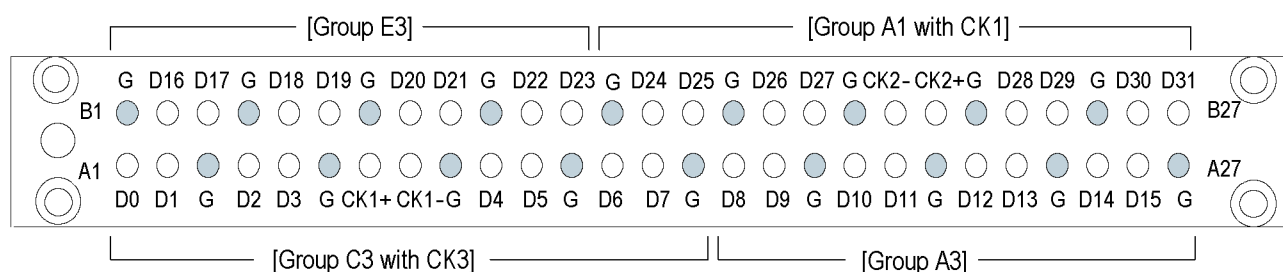

Figure 33: P6964 single-ended PCB footprint pinout detail

The following table lists the channel mapping to a logic analyzer module for a P6964 single-ended data, differential clock logic analyzer probe.

Table 6: Channel assignment for a P6964 single-ended data, differential clock logic analyzer probe

Pin number	Signal name	136 Channel
A1	D0	C3:7
A2	D1	C3:6
A3	GND	GND
A4	D2	C3:5
A5	D3	C3:4
A6	GND	GND
A7	CK1+	CK3+
A8	CK1-	CK3-
A9	GND	GND
A10	D4	C3:3
A11	D5	C3:2
A12	GND	GND
A13	D6	C3:1
A14	D7	C3:0
A15	GND	GND
A16	D8	A3:7
A17	D9	A3:6
A18	GND	GND
A19	D10	A3:5
A20	D11	A3:4
A21	GND	GND
A22	D12	A3:3
A23	D13	A3:2
A24	GND	GND
A25	D14	A3:1
A26	D15	A3:0
A27	GND	GND
B1	GND	GND
B2	D16	E3:0
B3	D17	E3:1
B4	GND	GND
B5	D18	E3:2
B6	D19	E3:3
B7	GND	GND

Table 6: Channel assignment for a P6964 single-ended data, differential clock logic analyzer probe (cont.)

Pin number	Signal name	136 Channel
B8	D20	E3:4
B9	D21	E3:5
B10	GND	GND
B11	D22	E3:6
B12	D23	E3:7
B13	GND	GND
B14	D24	A1:0
B15	D25	A1:1
B16	GND	GND
B17	D26	A1:2
B18	D27	A1:3
B19	GND	GND
B20	CK2-	CK1-
B21	CK2+	CK1+
B22	GND	GND
B23	D28	A1:4
B24	D29	A1:5
B25	GND	GND
B26	D30	A1:6
B27	D31	A1:7

P6980 differential probe with D-Max probing technology

The following figure shows the pad assignments, pad numbers, and signal names for the PCB footprint of the P6980 differential data and clock logic analyzer probe. (See Figure 34.) The P6980 probe has 16 data channels, and one clock or qualifier for each footprint. There are two footprints associated with one P6980 probe.

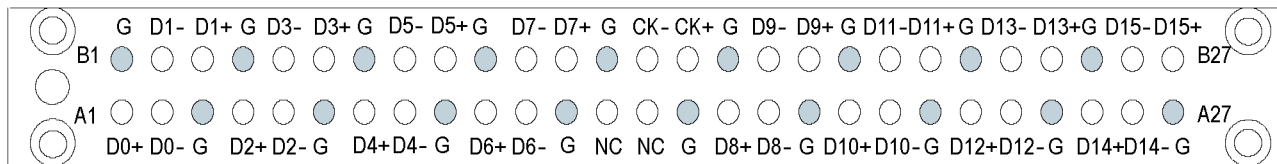

Figure 34: P6980 differential PCB footprint pinout detail

The following table lists the channel mapping to a 136 channel or 102 channel logic analyzer module for the P6980 differential data and clock logic analyzer probe.

Table 7: Channel assignment for a P6980 differential clock and data logic analyzer probe to a 136- or 102-channel logic analyzer module

Land pattern	Signal name	136-channel module only		136- and 102-channel modules					
		Probe 4	Probe 3	Probe 2	Probe 1	Probe 2	Probe 1	Probe 2	Probe 1
Pin number	Signal name	Head1	Head2	Head1	Head2	Head1	Head2	Head1	Head2
A1	D0+	E2:0+	E0:0+	A2:0+	D2:0+	A0:0+	D0:0+	C2:0+	C0:0+
A2	D0-	E2:0-	E0:0-	A2:0-	D2:0-	A0:0-	D0:0-	C2:0-	C0:0-
A3	GND	GND	GND	GND	GND	GND	GND	GND	GND
A4	D2+	E2:2+	E0:2+	A2:2+	D2:2+	A0:2+	D0:2+	C2:2+	C0:2+
A5	D2-	E2:2-	E0:2-	A2:2-	D2:2-	A0:2-	D0:2-	C2:2-	C0:2-
A6	GND	GND	GND	GND	GND	GND	GND	GND	GND
A7	D4+	E2:4+	E0:4+	A2:4+	D2:4+	A0:4+	D0:4+	C2:4+	C0:4+
A8	D4-	E2:4-	E0:4-	A2:4-	D2:4-	A0:4-	D0:4-	C2:4-	C0:4-
A9	GND	GND	GND	GND	GND	GND	GND	GND	GND
A10	D6+	E2:6+	E0:6+	A2:6+	D2:6+	A0:6+	D0:6+	C2:6+	C0:6+
A11	D6-	E2:6-	E0:6-	A2:6-	D2:6-	A0:6-	D0:6-	C2:6-	C0:6-
A12	GND	GND	GND	GND	GND	GND	GND	GND	GND
A13	NC	NC	NC	NC	NC	NC	ND	NC	NC
A14	NC	NC	NC	NC	NC	NC	ND	NC	NC
A15	GND	GND	GND	GND	GND	GND	GND	GND	GND
A16	D8+	E3:0+	E1:0+	A3:0+	D3:0+	A1:0+	D1:0+	C3:0+	C1:0+
A17	D8-	E3:0-	E1:0-	A3:0-	D3:0-	A1:0-	D1:0-	C3:0-	C1:0-
A18	GND	GND	GND	GND	GND	GND	GND	GND	GND
A19	D10+	E3:2+	E1:2+	A3:2+	D3:2+	A1:2+	D1:2+	C3:2+	C1:2+

Table 7: Channel assignment for a P6980 differential clock and data logic analyzer probe to a 136- or 102-channel logic analyzer module (cont.)

Land pattern		136-channel module only		136- and 102-channel modules					
		Probe 4		Probe 3		Probe 2		Probe 1	
Pin number	Signal name	Head1	Head2	Head1	Head2	Head1	Head2	Head1	Head2
A20	D10-	E3:2-	E1:2-	A3:2-	D3:2-	A1:2-	D1:2-	C3:2-	C1:2-
A21	GND	GND	GND	GND	GND	GND	GND	GND	GND
A22	D12+	E3:4+	E1:4+	A3:4+	D3:4+	A1:4+	D1:4+	C3:4+	C1:4+
A23	D12-	E3:4-	E1:4-	A3:4-	D3:4-	A1:4-	D1:4-	C3:4-	C1:4-
A24	GND	GND	GND	GND	GND	GND	GND	GND	GND
A25	D14+	E3:6+	E1:6+	A3:6+	D3:6+	A1:6+	D1:6+	C3:6+	C1:6+
A26	D14-	E3:6-	E1:6-	A3:6-	D3:6-	A1:6-	D1:6-	C3:6-	C1:6-
A27	GND	GND	GND	GND	GND	GND	GND	GND	GND
B1	GND	GND	GND	GND	GND	GND	GND	GND	GND
B2	D1-	E2:1-	E0:1-	A2:1-	D2:1-	A0:1-	D0:1-	C2:1-	C0:1-
B3	D1+	E2:1+	E0:1+	A2:1+	D2:1+	A0:1+	D0:1+	C2:1+	C0:1+
B4	GND	GND	GND	GND	GND	GND	GND	GND	GND
B5	D3-	E2:3-	E0:3-	A2:3-	D2:3-	A0:3-	D0:3-	C2:3-	C0:3-
B6	D3+	E2:3+	E0:3+	A2:3+	D2:3+	A0:3+	D0:3+	C2:3+	C0:3+
B7	GND	GND	GND	GND	GND	GND	GND	GND	GND
B8	D5-	E2:5-	E0:5-	A2:5-	D2:5-	A0:5-	D0:5-	C2:5-	C0:5-
B9	D5+	E2:5+	E0:5+	A2:5+	D2:5+	A0:5+	D0:5+	C2:5+	C0:5+
B10	GND	GND	GND	GND	GND	GND	GND	GND	GND
B11	D7-	E2:7-	E0:7-	A2:7-	D2:7-	A0:7-	D0:7-	C2:7-	C0:7-
B12	D7+	E2:7+	E0:7+	A2:7+	D2:7+	A0:7+	D0:7+	C2:7+	C0:7+
B13	GND	GND	GND	GND	GND	GND	GND	GND	GND
B14	CK-	Q3-	Q2-	CK0-	Q0-	CK1-	CK2-	CK3-	Q1-
B15	CK+	Q3+	Q2+	CK0+	Q0+	CK1+	CK2+	CK3+	Q1+
B16	GND	GND	GND	GND	GND	GND	GND	GND	GND
B17	D9-	E3:1-	E1:1-	A3:1-	D3:1-	A1:1-	D1:1-	C3:1-	C1:1-
B18	D9+	E3:1+	E1:1+	A3:1+	D3:1+	A1:1+	D1:1+	C3:1+	C1:1+
B19	GND	GND	GND	GND	GND	GND	GND	GND	GND
B20	D11-	E3:3-	E1:3-	A3:3-	D3:3-	A1:3-	D1:3-	C3:3-	C1:3-
B21	D11+	E3:3+	E1:3+	A3:3+	D3:3+	A1:3+	D1:3+	C3:3+	C1:3+
B22	GND	GND	GND	GND	GND	GND	GND	GND	GND
B23	D13-	E3:5-	E1:5-	A3:5-	D3:5-	A1:5-	D1:5-	C3:5-	C1:5-
B24	D13+	E3:5+	E1:5+	A3:5+	D3:5+	A1:5+	D1:5+	C3:5+	C1:5+

Table 7: Channel assignment for a P6980 differential clock and data logic analyzer probe to a 136- or 102-channel logic analyzer module (cont.)

Land pattern		136-channel module only		136- and 102-channel modules					
		Probe 4		Probe 3		Probe 2		Probe 1	
Pin number	Signal name	Head1	Head2	Head1	Head2	Head1	Head2	Head1	Head2
B25	GND	GND	GND	GND	GND	GND	GND	GND	GND
B26	D15-	E3:7-	E1:7-	A3:7-	D3:7-	A1:7-	D1:7-	C3:7-	C1:7-
B27	D15+	E3:7+	E1:7+	A3:7+	D3:7+	A1:7+	D1:7+	C3:7+	C1:7+

The following table lists the channel mapping to a 68 channel or 34 channel logic analyzer module for the P6980 differential data and clock logic analyzer probe.

Table 8: Channel assignment for a P6980 differential clock and data logic analyzer probe to a 68- or 34-channel logic analyzer module

Land pattern		68-channel module only for Probe 2		68- and 34-channel modules for Probe 1	
Pin number	Signal name	Head1	Head2	Head1	Head2
A1	D0+	A0:0+	D0:0+	C2:0+	A2:0+
A2	D0-	A0:0-	D0:0-	C2:0-	A2:0-
A3	GND	GND	GND	GND	GND
A4	D2+	A0:2+	D0:2+	C2:2+	A2:2+
A5	D2-	A0:2-	D0:2-	C2:2-	A2:2-
A6	GND	GND	GND	GND	GND
A7	D4+	A0:4+	D0:4+	C2:4+	A2:4+
A8	D4-	A0:4-	D0:4-	C2:4-	A2:4-
A9	GND	GND	GND	GND	GND
A10	D6+	A0:6+	D0:6+	C2:6+	A2:6+
A11	D6-	A0:6-	D0:6-	C2:6-	A2:6-
A12	GND	GND	GND	GND	GND
A13	NC	NC	ND	NC	NC
A14	NC	NC	ND	NC	NC
A15	GND	GND	GND	GND	GND
A16	D8+	A1:0+	D1:0+	C3:0+	A3:0+
A17	D8-	A1:0-	D1:0-	C3:0-	A3:0-
A18	GND	GND	GND	GND	GND
A19	D10+	A1:2+	D1:2+	C3:2+	A3:2+
A20	D10-	A1:2-	D1:2-	C3:2-	A3:2-
A21	GND	GND	GND	GND	GND
A22	D12+	A1:4+	D1:4+	C3:4+	A3:4+

Table 8: Channel assignment for a P6980 differential clock and data logic analyzer probe to a 68- or 34-channel logic analyzer module (cont.)

Land pattern		68-channel module only for Probe 2		68- and 34-channel modules for Probe 1	
Pin number	Signal name	Head1	Head2	Head1	Head2
A23	D12-	A1:4-	D1:4-	C3:4-	A3:4-
A24	GND	GND	GND	GND	GND
A25	D14+	A1:6+	D1:6+	C3:6+	A3:6+
A26	D14-	A1:6-	D1:6-	C3:6-	A3:6-
A27	GND	GND	GND	GND	GND
B1	GND	GND	GND	GND	GND
B2	D1-	A0:1-	D0:1-	C2:1-	A2:1-
B3	D1+	A0:1+	D0:1+	C2:1+	A2:1+
B4	GND	GND	GND	GND	GND
B5	D3-	A0:3-	D0:3-	C2:3-	A2:3-
B6	D3+	A0:3+	D0:3+	C2:3+	A2:3+
B7	GND	GND	GND	GND	GND
B8	D5-	A0:5-	D0:5-	C2:5-	A2:5-
B9	D5+	A0:5+	D0:5+	C2:5+	A2:5+
B10	GND	GND	GND	GND	GND
B11	D7-	A0:7-	D0:7-	C2:7-	A2:7-
B12	D7+	A0:7+	D0:7+	C2:7+	A2:7+
B13	GND	GND	GND	GND	GND
B14	CK-	CK1-	CK2-	CK3-	CK0-
B15	CK+	CK1+	CK2+	CK3+	CK0+
B16	GND	GND	GND	GND	GND
B17	D9-	A1:1-	D1:1-	C3:1-	A3:1-
B18	D9+	A1:1+	D1:1+	C3:1+	A3:1+
B19	GND	GND	GND	GND	GND
B20	D11-	A1:3-	D1:3-	C3:3-	A3:3-
B21	D11+	A1:3+	D1:3+	C3:3+	A3:3+
B22	GND	GND	GND	GND	GND
B23	D13-	A1:5-	D1:5-	C3:5-	A3:5-
B24	D13+	A1:5+	D1:5+	C3:5+	A3:5+
B25	GND	GND	GND	GND	GND
B26	D15-	A1:7-	D1:7-	C3:7-	A3:7-
B27	D15+	A1:7+	D1:7+	C3:7+	A3:7+

P6982 differential probe with D-Max probing technology

The following figure shows the pad assignments, pad numbers, and signal names for the PCB footprint of the P6982 differential data and clock logic analyzer probe. The P6982 probe has 16 data channels, and one clock or qualifier for each footprint.

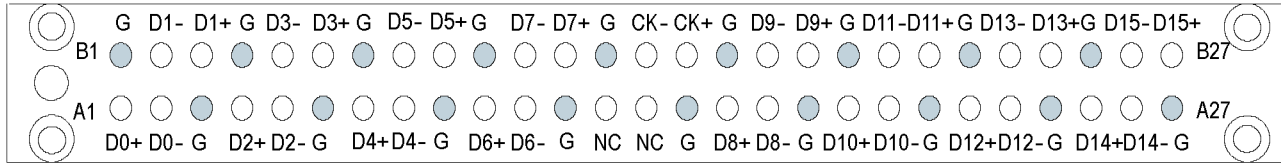

Figure 35: P6982 differential PCB footprint pinout detail

The following table lists the channel mapping to a 136 channel or 102 channel logic analyzer module for the P6982 differential data and clock logic analyzer probe.

Table 9: Channel assignment for a P6982 differential clock and data logic analyzer probe to a 136- or 102-channel logic analyzer module

Land pattern		136-channel module only	136- and 102-channel modules		
Pin number	Signal name	Probe 4	Probe 3	Probe 2	Probe 1
A1	D0+	E2:0+	A2:0+	A0:0+	C2:0+
A2	D0-	E2:0-	A2:0-	A0:0-	C2:0-
A3	GND	GND	GND	GND	GND
A4	D2+	E2:2+	A2:2+	A0:2+	C2:2+
A5	D2-	E2:2-	A2:2-	A0:2-	C2:2-
A6	GND	GND	GND	GND	GND
A7	D4+	E2:4+	A2:4+	A0:4+	C2:4+
A8	D4-	E2:4-	A2:4-	A0:4-	C2:4-
A9	GND	GND	GND	GND	GND
A10	D6+	E2:6+	A2:6+	A0:6+	C2:6+
A11	D6-	E2:6-	A2:6-	A0:6-	C2:6-
A12	GND	GND	GND	GND	GND
A13	NC	NC	NC	NC	NC
A14	NC	NC	NC	NC	NC
A15	GND	GND	GND	GND	GND
A16	D8+	E3:0+	A3:0+	A1:0+	C3:0+
A17	D8-	E3:0-	A3:0-	A1:0-	C3:0-
A18	GND	GND	GND	GND	GND
A19	D10+	E3:2+	A3:2+	A1:2+	C3:2+
A20	D10-	E3:2-	A3:2-	A1:2-	C3:2-
A21	GND	GND	GND	GND	GND

Table 9: Channel assignment for a P6982 differential clock and data logic analyzer probe to a 136- or 102-channel logic analyzer module (cont.)

Land pattern		136-channel module only	136- and 102-channel modules		
Pin number	Signal name	Probe 4	Probe 3	Probe 2	Probe 1
A22	D12+	E3:4+	A3:4+	A1:4+	C3:4+
A23	D12-	E3:4-	A3:4-	A1:4-	C3:4-
A24	GND	GND	GND	GND	GND
A25	D14+	E3:6+	A3:6+	A1:6+	C3:6+
A26	D14-	E3:6-	A3:6-	A1:6-	C3:6-
A27	GND	GND	GND	GND	GND
B1	GND	GND	GND	GND	GND
B2	D1-	E2:1-	A2:1-	A0:1-	C2:1-
B3	D1+	E2:1+	A2:1+	A0:1+	C2:1+
B4	GND	GND	GND	GND	GND
B5	D3-	E2:3-	A2:3-	A0:3-	C2:3-
B6	D3+	E2:3+	A2:3+	A0:3+	C2:3+
B7	GND	GND	GND	GND	GND
B8	D5-	E2:5-	A2:5-	A0:5-	C2:5-
B9	D5+	E2:5+	A2:5+	A0:5+	C2:5+
B10	GND	GND	GND	GND	GND
B11	D7-	E2:7-	A2:7-	A0:7-	C2:7-
B12	D7+	E2:7+	A2:7+	A0:7+	C2:7+
B13	GND	GND	GND	GND	GND
B14	CK-	Q3-	CK0-	CK1-	CK3-
B15	CK+	Q3+	CK0+	CK1+	CK3+
B16	GND	GND	GND	GND	GND
B17	D9-	E3:1-	A3:1-	A1:1-	C3:1-
B18	D9+	E3:1+	A3:1+	A1:1+	C3:1+
B19	GND	GND	GND	GND	GND
B20	D11-	E3:3-	A3:3-	A1:3-	C3:3-
B21	D11+	E3:3+	A3:3+	A1:3+	C3:3+
B22	GND	GND	GND	GND	GND
B23	D13-	E3:5-	A3:5-	A1:5-	C3:5-
B24	D13+	E3:5+	A3:5+	A1:5+	C3:5+
B25	GND	GND	GND	GND	GND
B26	D15-	E3:7-	A3:7-	A1:7-	C3:7-
B27	D15+	E3:7+	A3:7+	A1:7+	C3:7+

The following table lists the channel mapping to a 68 channel or 34 channel logic analyzer module for the P6982 differential data and clock logic analyzer probe.

Table 10: Channel assignment for a P6982 differential clock and data logic analyzer probe to a 68- or 34-channel logic analyzer module

Pin number	Signal name	68-channel module only for Probe 2	68- and 34-channel modules for Probe 1
A1	D0+	A0:0+	C2:0+
A2	D0-	A0:0-	C2:0-
A3	GND	GND	GND
A4	D2+	A0:2+	C2:2+
A5	D2-	A0:2-	C2:2-
A6	GND	GND	GND
A7	D4+	A0:4+	C2:4+
A8	D4-	A0:4-	C2:4-
A9	GND	GND	GND
A10	D6+	A0:6+	C2:6+
A11	D6-	A0:6-	C2:6-
A12	GND	GND	GND
A13	NC	NC	NC
A14	NC	NC	NC
A15	GND	GND	GND
A16	D8+	A1:0+	C3:0+
A17	D8-	A1:0-	C3:0-
A18	GND	GND	GND
A19	D10+	A1:2+	C3:2+
A20	D10-	A1:2-	C3:2-
A21	GND	GND	GND
A22	D12+	A1:4+	C3:4+
A23	D12-	A1:4-	C3:4-
A24	GND	GND	GND
A25	D14+	A1:6+	C3:6+
A26	D14-	A1:6-	C3:6-
A27	GND	GND	GND
B1	GND	GND	GND
B2	D1-	A0:1-	C2:1-
B3	D1+	A0:1+	C2:1+
B4	GND	GND	GND
B5	D3-	A0:3-	C2:3-
B6	D3+	A0:3+	C2:3+
B7	GND	GND	GND

Table 10: Channel assignment for a P6982 differential clock and data logic analyzer probe to a 68- or 34-channel logic analyzer module (cont.)

Pin number	Signal name	68-channel module only for Probe 2	68- and 34-channel modules for Probe 1
B8	D5-	A0:5-	C2:5-
B9	D5+	A0:5+	C2:5+
B10	GND	GND	GND
B11	D7-	A0:7-	C2:7-
B12	D7+	A0:7+	C2:7+
B13	GND	GND	GND
B14	CK-	CK1-	CK3-
B15	CK+	CK1+	CK3+
B16	GND	GND	GND
B17	D9-	A1:1-	C3:1-
B18	D9+	A1:1+	C3:1+
B19	GND	GND	GND
B20	D11-	A1:3-	C3:3-
B21	D11+	A1:3+	C3:3+
B22	GND	GND	GND
B23	D13-	A1:5-	C3:5-
B24	D13+	A1:5+	C3:5+
B25	GND	GND	GND
B26	D15-	A1:7-	C3:7-
B27	D15+	A1:7+	C3:7+

Specifications

Mechanical and electrical specifications

The following table lists the mechanical and electrical specifications for the P6900 Series Probes. The electrical specifications apply when the probe is connected between a compatible logic analyzer and a target system. (See Table 11.)

Refer to the *Tektronix Logic Analyzer Family Product Specifications* document (Tektronix part number 071-1344-xx) available on the *Tektronix Logic Analyzer Family Product Documentation* CD or downloadable from the Tektronix Web site for a complete list of specifications, including overall system specifications.

Table 11: Mechanical and electrical specifications

Characteristic	P6960, P6962, P6964	P6960HS	P6980, P6982
Threshold accuracy	$\pm(35 \text{ mV} \pm 1\% \text{ of setting})$	$\pm(35 \text{ mV} \pm 1\% \text{ of setting})$	$\pm(35 \text{ mV} \pm 1\% \text{ of setting})$
Input resistance	20 k Ω $\pm 1\%$	11.7 k Ω $\pm 1\%$	20 k Ω $\pm 1\%$
Input capacitance	0.5 pF	0.5 pF	0.5 pF
Minimum digital signal swing (TLA7AAx/TLA7ACx)	300 mV single-ended	150 mV single-ended	150 mV differential each side
Minimum digital signal swing (TLA7BBx)	200 mV single-ended	100 mV single-ended	100 mV differential each side
Maximum nondestructive input signal to probe	$\pm 15 \text{ V}$	$\pm 7.5 \text{ V}$	$\pm 15 \text{ V}$
Delay from probe tip to module input connector	7.70 ns ± 60 ps	7.70 ns ± 60 ps	7.70 ns ± 60 ps
Probe length	1.8 m (6 ft)	1.8 m (6 ft)	1.8 m (6 ft)
Operating range	+5 V to -2.5 V	+2.5 V to -1.25 V	+5 V to -2.5 V

NOTE. Because the length of the probes are electrically similar, they can be interchanged without problems.

The following table shows the environmental specifications for the probes.

Table 12: Environmental specifications

Characteristic	P6900
Temperature	
Operating	0 °C to +50 °C (0 °F to +122 °F)
Nonoperating	-51 °C to +71 °C (-60 °F to +160 °F)
Humidity	
	10 °C to 30 °C (+50 °F to +86 °F) 95% relative humidity
	30 °C to 40 °C (+86 °F to +104 °F) 75% relative humidity
	40 °C to 50 °C (+104 °F to +122 °F) 45% relative humidity
Altitude	
Operating	9843 ft (3,000 m)
Nonoperating	40,000 ft (12,192 m)
Electrostatic immunity	6 kV

Maintenance

The P6900 Series High-Density Logic Analyzer Probes do not require scheduled or periodic maintenance. Refer to the Functional Check section below to verify the basic functionality of the probes.

Probe calibration

To confirm that the probes meet or exceed the performance requirements for published specifications with a compatible logic analyzer module, you must return the probes to your local Tektronix service center.

Perform the functional check

Connect the logic analyzer probes to a signal source, start an acquisition, and verify that the acquired data is displayed in either the listing or waveform windows.

Inspect and clean the probes



CAUTION. *To prevent damage during the probe connection process, do not touch the exposed edge of the interface clip. Do not drag the contacts against a hard edge or corner.*

To maintain a reliable electrical contact, keep the probes free of dirt, dust, and contaminants. Remove dirt and dust with a soft brush. Avoid brushing or rubbing the c-spring contacts. For more extensive cleaning, use only a damp cloth. Never use abrasive cleaners or organic solvents.

Service strategy

The P6900 Series Probes use replaceable c-spring cLGA clips. If a probe failure other than the cLGA clip occurs, return the entire probe to your Tektronix service center for repair.

Replace the cLGA Clip

For replacement part number information, refer to the *Replaceable Parts List*. To replace the clip, do the following:

1. Gently pull one side of the clip away from the probe head, as shown in the following figure, and then remove the entire clip.
2. Align the new clip to the probe head and gently snap it into place.
3. Test the probe to confirm that all channels are functional.

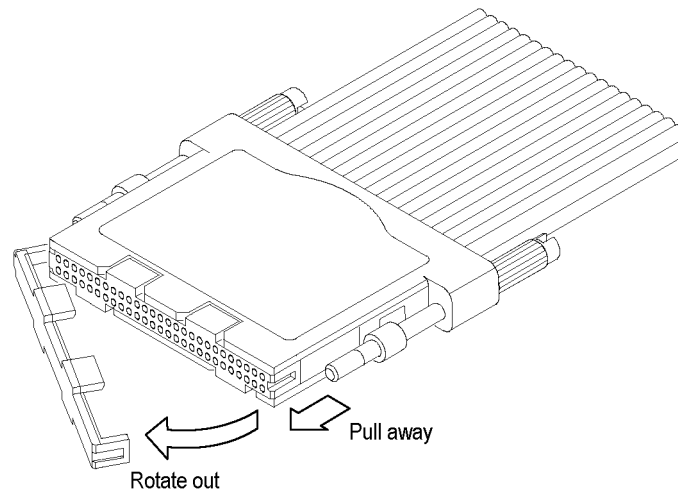

Figure 36: Replacing the cLGA clip

Legacy probe and attachment support

- Nexus Technology, a Tektronix Partner, sells accessories that allow you to use the P6960 probe with legacy attachment connectors as well as utilize the P6960 probe footprint with select P68xx and P64xx probe products.
- Please contact Nexus Technology directly for more information.
- Contact Information:

Nexus Technology

Phone: 877-595-8116

Fax: 877-595-8118

Repackaging instructions

Use the original packaging, if possible, to return or store the probes. If the original packaging is not available, use a corrugated cardboard shipping carton. Add cushioning material to prevent the probes from moving inside the shipping container.

Enclose the following information when shipping the probe to a Tektronix Service Center.

- Owner's address
- Name and phone number of a contact person
- Type of probe
- Reason for return
- Full description of the service required

Replaceable parts

This chapter contains a list of the replaceable components for the P6900 Series Probes. Use this list to identify and order replacement parts.

Parts ordering information

Replacement parts are available through your local Tektronix field office or representative.

Changes to Tektronix products are sometimes made to accommodate improved components as they become available and to give you the benefit of the latest improvements. Therefore, when ordering parts, it is important to include the following information in your order.

- Part number
- Instrument type or model number
- Instrument serial number
- Instrument modification number, if applicable

If you order a part that has been replaced with a different or improved part, your local Tektronix field office or representative will contact you concerning any change in part number.

Replaceable parts list

The P6900 Series Probes contain only the cLGA clip as a replaceable part. If probe failure occurs, return the entire probe to your Tektronix service representative for repair.

Refer to the following list for replaceable items:

Table 13: Parts list column descriptions

Column	Column name	Description
1	Figure & index number	Items in this section reference figure and index numbers to the exploded view illustrations that follow.
2	Tektronix part number	Use this part number when ordering replacement parts from Tektronix.
3 and 4	Serial number	Column three indicates the serial number at which the part was first effective. Column four indicate the serial number at which the part was discontinued. No entries indicates the part is good for all serial numbers.
5	Qty	This indicates the quantity of parts used.
6	Name & description	An item name is separated from the description by a colon (:). Because of space limitations, an item name may sometimes appear as incomplete. Use the U.S. Federal Catalog handbook H6-1 for further item name identification.

Abbreviations conform to American National Standard ANSI Y1.1-1972.

Table 14: P6960 replaceable parts list

Figure & index number	Tektronix part number	Serial no. effective	Serial no. discont'd	Qty	Name & description
(See Figure 37.)-1	010-6960-12			1	P6960 PROBE (INCLUDES SHEET OF LABELS)
-2	020-2622-XX			1	COMPONENT KIT, CLGA INTERFACE CLIP PREINSTALLED ON THE PROBE; 1 EA, P6900 SERIES PROBE, SAFETY CONTROLLED
-3	200-4893-XX			1	COVER,PROTECTIVE; BLACK VINYL (PLASTISOL) WITH STATIC-DISSIPATIVE ADDITIVE
	020-2908-XX			1	P6900 RETENTION ASSEMBLY KIT, QTY 2
	346-0300-XX			1	STRAP,VELCRO;ONE WRAP,BLACK,0.500W X 8.00L,QTY 2 BAGGED & LABELED
	003-1890-XX			1	TOOL,HAND; USED TO TIGHTEN PROBE HEAD TO DUT
	071-1539-XX			1	MANUAL,TECH; TRIFOLD,INSTALLATION/LABELING INSTRUCTIONS FOR P6960
	335-1208-XX			1	P6960 PROBE, SHEET OF LABELS

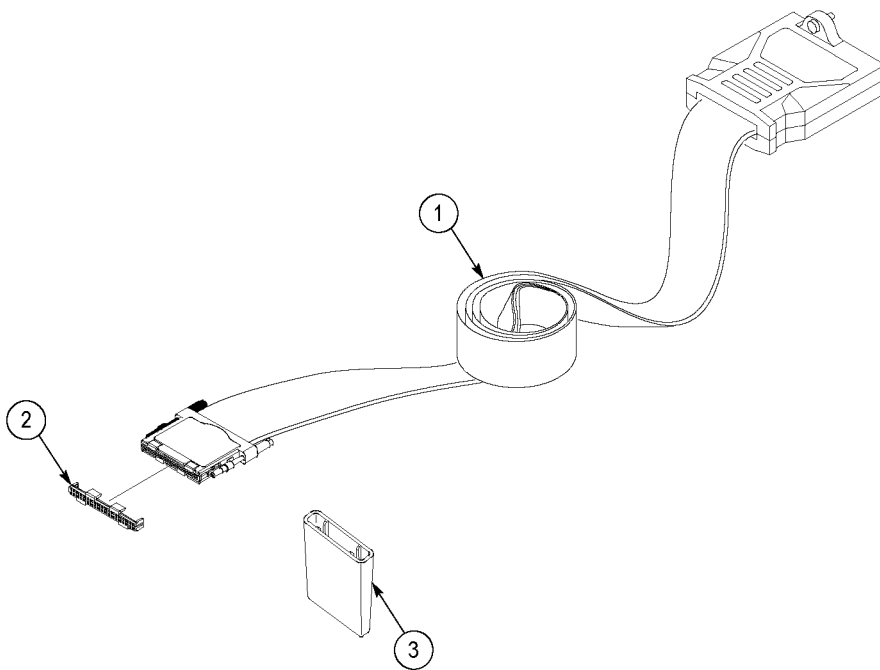

Figure 37: P6960 High-Density probe accessories

Table 15: P6960HS replaceable parts list

Figure & index number	Tektronix part number	Serial no. effective	Serial no. discont'd	Qty	Name & description
(See Figure 38.)-1	010-0825-10			1	P6960HS PROBE (INCLUDES SHEET OF LABELS)
-2	020-2622-XX			1	COMPONENT KIT, CLGA INTERFACE CLIP PREINSTALLED ON THE PROBE; 1 EA, P6900 SERIES PROBE, SAFETY CONTROLLED
-3	200-4893-XX			1	COVER, PROTECTIVE; BLACK VINYL (PLASTISOL) WITH STATIC-DISSIPATIVE ADDITIVE
	020-2908-XX			1	P6900 RETENTION ASSEMBLY KIT, QTY 2
	346-0300-XX			1	STRAP, VELCRO; ONE WRAP, BLACK, 0.500W X 8.00L, QTY 2 BAGGED & LABELED
	003-1890-XX			1	TOOL, HAND; USED TO TIGHTEN PROBE HEAD TO DUT
	071-1539-XX			1	MANUAL, TECH; TRIFOLD, INSTALLATION/LABELING INSTRUCTIONS FOR P6960
	335-3009-XX			1	P6960 PROBE, SHEET OF LABELS

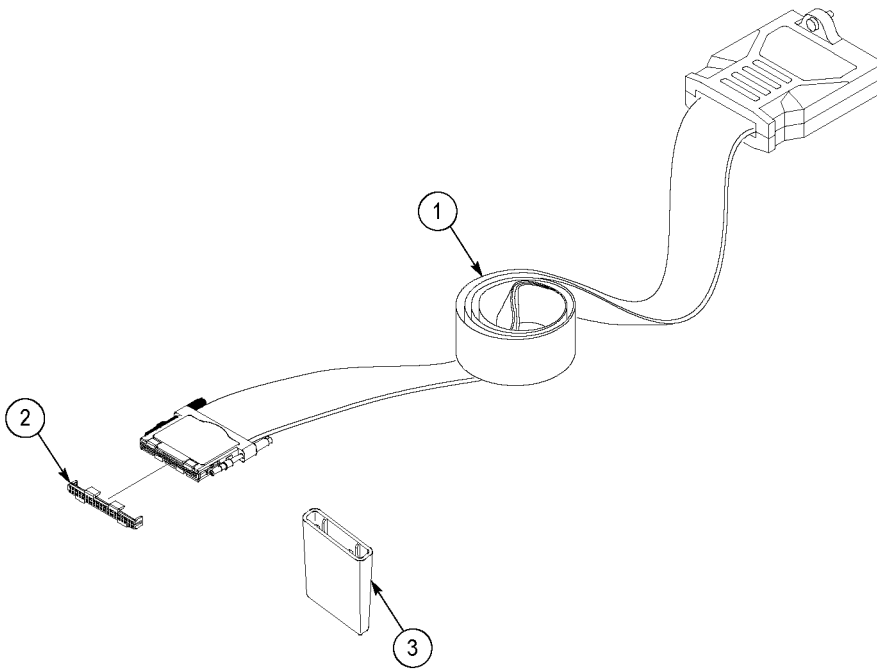

Figure 38: P6960HS High-Density probe accessories

Table 16: P6962 replaceable parts list

Figure & index number	Tektronix part number	Serial no. effective	Serial no. discontinued	Qty	Name & description
39--1	010-6962-10			1	P6962 PROBE (INCLUDES SHEET OF LABELS)
-2	020-2622-XX			1	COMPONENT KIT, CLGA INTERFACE CLIP PREINSTALLED ON THE PROBE; 1 EA, P6900 SERIES PROBE, SAFETY CONTROLLED
-3	200-4893-XX			1	COVER,PROTECTIVE; BLACK VINYL (PLASTISOL) WITH STATIC-DISSIPATIVE ADDITIVE
	020-2908-XX			1	P6900 RETENTION ASSEMBLY KIT, QTY 2
	346-0300-XX			1	STRAP,VELCRO;ONE WRAP,BLACK,0.500W X 8.00L,QTY 2 BAGGED & LABELED
	003-1890-XX			1	TOOL,HAND; USED TO TIGHTEN PROBE HEAD TO DUT
	071-2153-XX			1	MANUAL,TECH; QUADFOLD,INSTALLATION/LABELING INSTRUCTIONS FOR P6962
	335-1772-XX			1	P6962 PROBE, SHEET OF LABELS

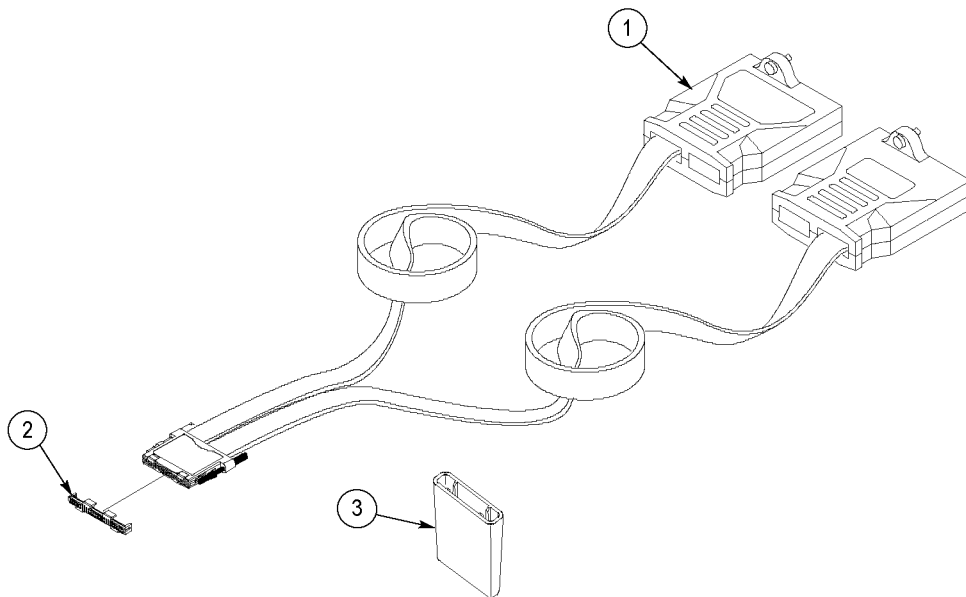

Figure 39: P6962 High-Density probe accessories

Table 17: P6964 replaceable parts list

Figure & index number	Tektronix part number	Serial no. effective	Serial no. discont'd	Qty	Name & description
40--1	010-6964-11			1	P6964 PROBE (INCLUDES SHEET OF LABELS)
-2	020-2622-XX			1	COMPONENT KIT, CLGA INTERFACE CLIP PREINSTALLED ON THE PROBE; 1 EA, P6900 SERIES PROBE, SAFETY CONTROLLED
-3	200-4893-XX			1	COVER,PROTECTIVE; BLACK VINYL (PLASTISOL) WITH STATIC-DISSIPATIVE ADDITIVE
	020-2908-XX			1	P6900 RETENTION ASSEMBLY KIT, QTY 2
	346-0300-XX			1	STRAP,VELCRO;ONE WRAP,BLACK,0.500W X 8.00L,QTY 2 BAGGED & LABELED
	003-1890-XX			1	TOOL,HAND; USED TO TIGHTEN PROBE HEAD TO DUT
	071-1685-XX			1	MANUAL,TECH; TRIFOLD,INSTALLATION/LABELING INSTRUCTIONS FOR P6964
	335-1315-XX			1	P6964 PROBE, SHEET OF LABELS

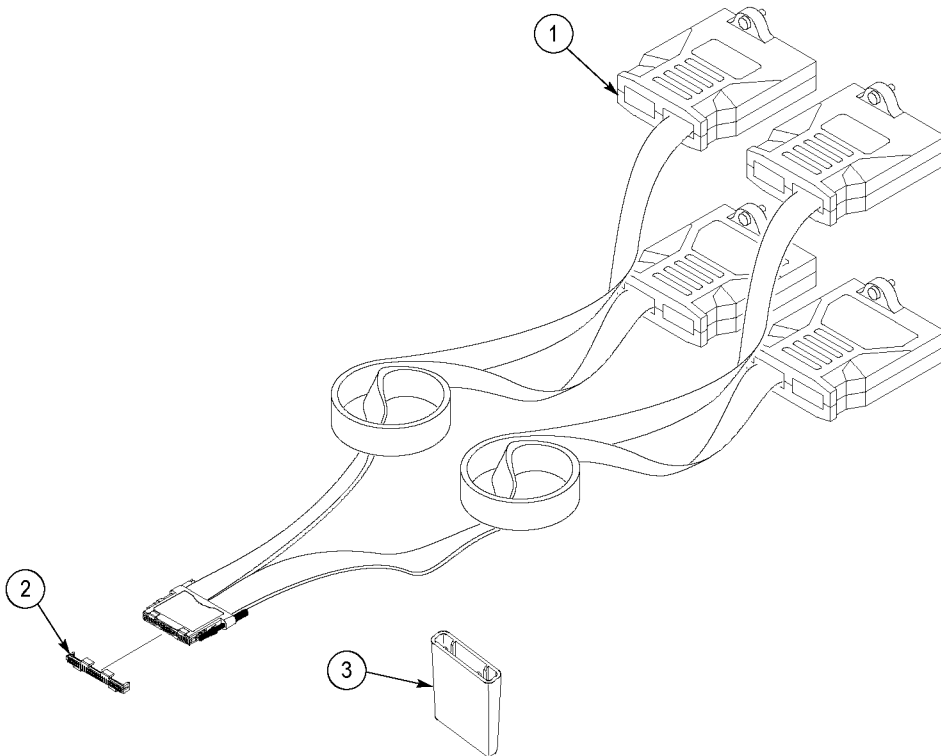

Figure 40: P6964 High-Density probe accessories

Table 18: P6980 replaceable parts list

Figure & index number	Tektronix part number	Serial no. effective	Serial no. discont'd	Qty	Name & description
41--1	010-6980-12			1	P6980 PROBE SET (INCLUDES SHEET OF LABELS)
-2	020-2622-XX			2	COMPONENT KIT, CLGA INTERFACE CLIP PREINSTALLED ON THE PROBE; 1 EA, P6900 SERIES PROBE, SAFETY CONTROLLED
-3	200-4893-XX			2	COVER,PROTECTIVE; BLACK VINYL (PLASTISOL) WITH STATIC-DISSIPATIVE ADDITIVE
	020-2908-XX			1	P6900 RETENTION ASSEMBLY KIT, QTY 2
	346-0300-00			1	STRAP,VELCRO;ONE WRAP,BLACK,0.500W X 8.00L,QTY 2 BAGGED & LABELED
	003-1890-XX			1	TOOL,HAND; USED TO TIGHTEN PROBE HEAD TO DUT
	071-1542-XX			1	MANUAL,TECH; TRIFOLD,INSTALLATION/LABELING INSTRUCTIONS FOR P6980
	335-1209-XX			1	P6980 PROBE, SHEET OF LABELS

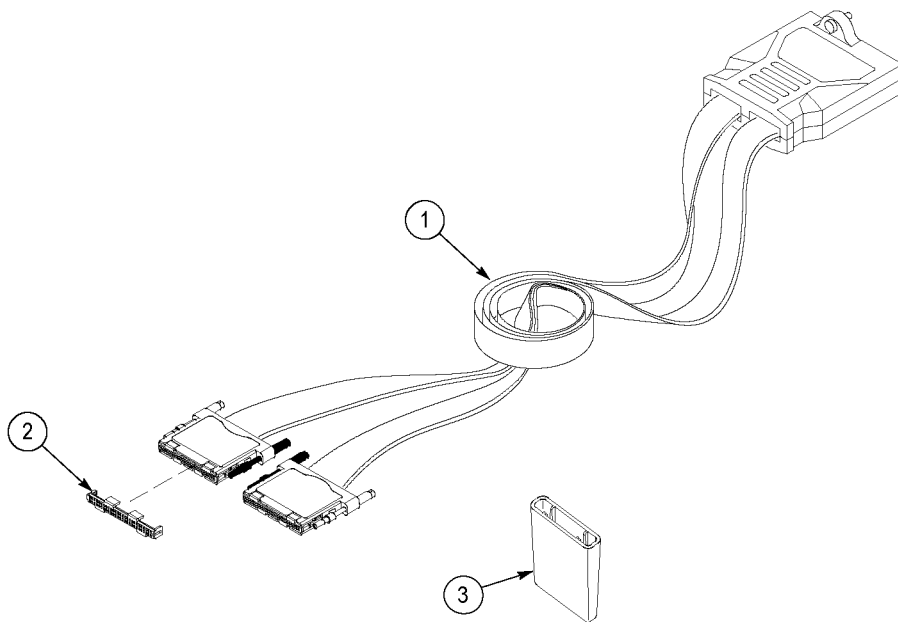

Figure 41: P6980 High-Density Differential probe accessories

Table 19: P6982 replaceable parts list

Figure & index number	Tektronix part number	Serial no. effective	Serial no. discont'd	Qty	Name & description
42--1	010-6982-11			1	P6982 PROBE SET (INCLUDES SHEET OF LABELS)
-2	020-2622-XX			1	COMPONENT KIT, CLGA INTERFACE CLIP PREINSTALLED ON THE PROBE; 1 EA, P6900 SERIES PROBE, SAFETY CONTROLLED
-3	200-4893-XX			1	COVER,PROTECTIVE; BLACK VINYL (PLASTISOL) WITH STATIC-DISSIPATIVE ADDITIVE
	020-2908-XX			1	P6900 RETENTION ASSEMBLY KIT, QTY 2
	346-0300-XX			1	STRAP,VELCRO;ONE WRAP,BLACK,0.500W X 8.00L,QTY 2 BAGGED & LABELED
	003-1890-XX			1	TOOL,HAND; USED TO TIGHTEN PROBE HEAD TO DUT
	071-1684-XX			1	MANUAL,TECH; TRIFOLD,INSTALLATION/LABELING INSTRUCTIONS FOR P6982
	335-1313-XX			1	P6982 PROBE, SHEET OF LABELS

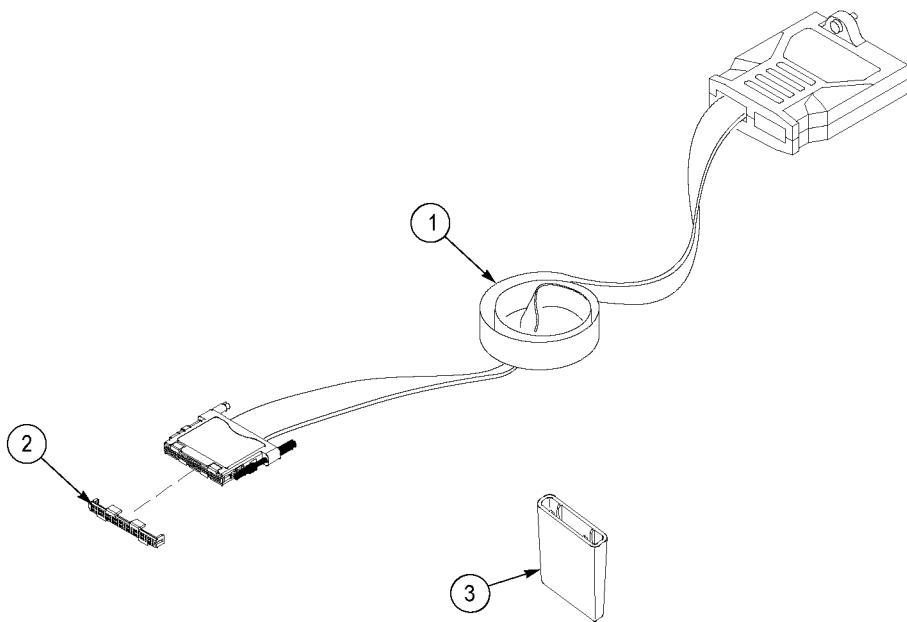

Figure 42: P6982 High-Density Differential probe accessories

Table 20: P6900 Series Probes optional accessories

Figure & index number	Tektronix part number	Serial no. effective	Serial no. discont'd	Qty	Name & description
43--1	196-3494-XX			1	P6900 FLYING LEADSET
-2	020-3043-XX			2	ADAPTER KIT; BAG OF 20 KLIPCHIP ADAPTER (40 TOTAL)
-3	020-2908-XX			1	P6900 RETENTION ASSEMBLY KIT, QTY 2
-4	020-2910-XX			1	P6900 RETENTION ASSEMBLY KIT, QTY 50

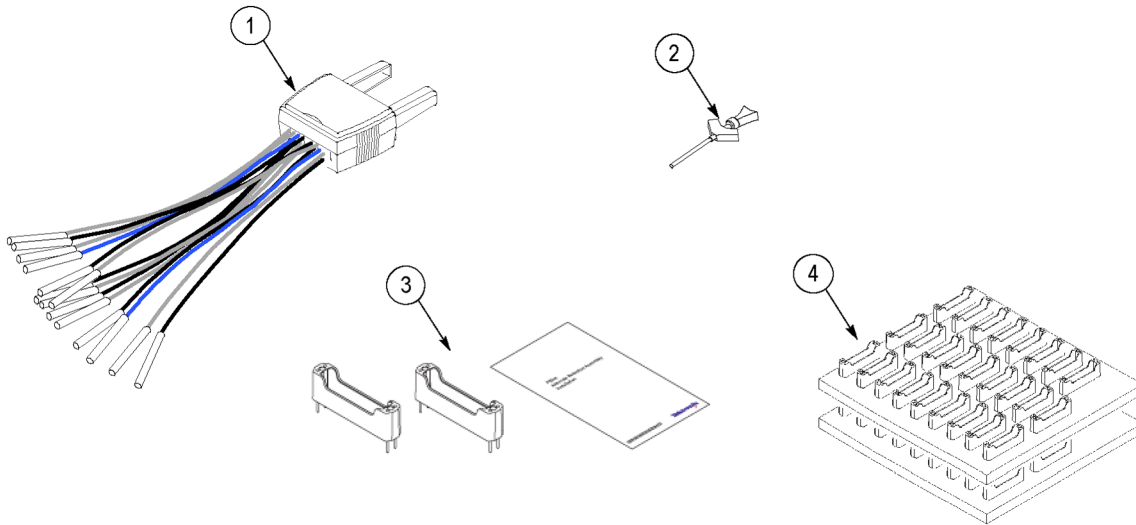

Figure 43: Optional accessories

Index

Symbols and Numbers

3D CAD file, 31

A

adapters
definition of, viii
alternate retention assembly, 14, 30
dimensions, 30
analog signals
probing, 26
attaching probe labels, 1

C

calibration
probe, 55
channel assignment, 37
See also channel mapping
channel assignment tables, 37
channel mapping
P6960, 37
P6960HS, 37
P6962, 40
P6964, 42
P6980, 44, 46
P6982, 48, 50
cleaning
compression footprints, 13
inspection and, 55
cLGA, vi
cLGA interface clip
handling, 15
replacing, 56
clocking
source synchronous, 22
clocks, 21
commonly used terms, vi
compression footprint, vi, 13
connecting
probes to logic analyzer, 10
probes to target system, 11

D

designing an interface, 21
electrical considerations, 33
mechanical
considerations, 32
differential input amplitude
definition, vii
dimensions
alternate retention
assembly, 30
footprint, 30, 31
probe, 27
probe footprint, 35
retention posts, 29
documentation
related, v

E

electrical considerations
P6900 Series Probes load
model, 33
transmission lines, 33
electrical specifications, 53
environmental specifications, 54

F

file attachments, 31
flying lead set, vii
footprint
dimensions, 30, 31
functional check, viii, 55

H

High Density Differential Probe,
P6980, 7
High Density Differential Probe,
P6982, 8
High Density Probe, P6960, 2
High Density Probe, P6960HS, 3
High Density Probe, P6962, 4
High Density Probe, P6964, 6
high resolution timing modes, 25

I

inspection and cleaning, 55
installing retention posts, 11
interface
design, 21

K

keepout area, viii, 29, 30

L

load model
P6900 Series Probes, 33
logic analyzer
connecting probes, 10

M

maintenance, 55
functional check, 55
inspection and cleaning, 55
probe calibration, 55
repackaging instructions, 57
service strategy, 56
mechanical considerations
physical attachment
requirements for P6900
Series Probes, 33
mechanical specifications, 53
merged module, 22
module, viii

O

ordering parts, 59

P

P6960
channel mapping, 37
pinout, 37
P6960HS
channel mapping, 37
pinout, 37

- P6962
 - channel mapping, 40
 - pinout, 39
- P6964
 - channel mapping, 42
 - pinout, 41
- P6980
 - channel mapping, 44, 46
 - pinout, 44
- P6982
 - channel mapping, 48, 50
 - pinout, 48
- parts
 - ordering information, 59
 - using the replaceable parts list, 60
- PCB (printed circuit board), viii
- probe
 - dimensions, 27
 - troubleshooting DUT connections, 17
- probe heads
 - handling the interface clips, 15
- probes
 - adapter, definition of, viii
 - calibration, 55
 - cleaning the compression footprints, 13
 - connecting probes to the logic analyzer, 10
 - connecting probes to the target system, 11
 - definition of, viii
 - footprint dimensions, 35
 - head, definition of, viii
 - labels, 1
 - P6960 High Density Probe, 2
 - P6960HS High Density Probe, 3
 - P6962 High Density Probe, 4
 - P6964 High Density Probe, 6
 - P6980 High Density Differential Probe, 7
 - P6982 High Density Differential Probe, 8
 - product description, 1
 - returning, 57
 - storing, 20, 57
- probing analog signals, 26
- Q**
 - qualifiers, 21
- R**
 - range recognition, 26
 - related documentation, v
 - repackaging instructions, 57
 - replacement parts, 59, 60
 - replacing the cLGA interface clip, 56
 - requirements
 - physical attachment for the P6900 Series Probes, 33
- retention post wires
 - using the correct retention post wires, 11
- retention posts, 11
 - dimensions, 29
 - installing, 11
- returning probes, 57
- S**
 - service strategy, 56
 - signal connections, 21
 - signal fixturing, 21
 - signal routing, 32
 - SMT KlipChip, viii
 - specifications
 - electrical, 53
 - environmental, 54
 - mechanical, 53
 - storing probes, 20, 57
- T**
 - target system
 - connecting probes, 11
 - terms
 - commonly used, vi
 - timing modes
 - high resolution, 25
 - transmission lines, 33
 - troubleshooting
 - probe DUT connections, 17
- U**
 - using the correct retention post wires, 11
- V**
 - via-in-pad, 36
 - vias, 36