

**P7600 Series Probes
Adapters**

Instructions

cables should be short (<6 in /152 mm) and have high-quality connectors at both ends.

The P76TA Solder Tip Adapter allows you to connect to P7500 Series TriMode solder-down tips; for example, the P75PST Performance Solder Tip.

The P76CA-BTI292 Coax Adapter allows the conversion of the P76TA or P76CA adapters' Buffered Tip Interface to a pair of 2.92 mm connectors. Using this adapter, the distance between the circuit under test and the oscilloscope can be extended. High bandwidth, low skew cable pairs should be used for this extended reach.

let the weight of the probe head pull on the coax connectors if the probe is hanging vertically off of the circuit.

Connection Procedures

Connect the adapter to the probe head or P76CA-BTI292 Coax Adapter, and then connect the cable or use the solder-down procedure for your circuit connection. These procedures are described in detail below.

Adapter to Probe Head or P76CA-BTI292

1. Align the adapter to the probe head or the P76CA-BTI292 adapter.
2. Push the adapter in until it seats against the probe head or adapter.
3. Use the 2 mm hex wrench to tighten the screw on the adapter.

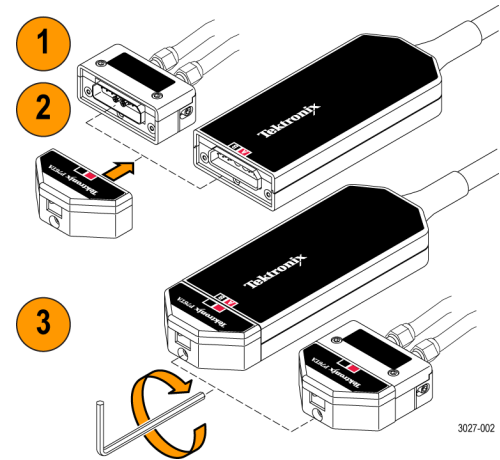
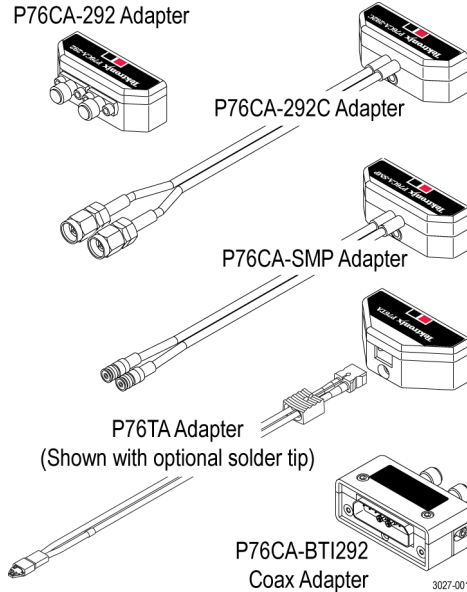

Overview

These instructions apply to the adapters below:

Adapter	Description
P76CA-292	2.92 mm Coax Adapter ¹
P76CA-292C	2.92 mm Coax Adapter with Cables
P76CA-SMP	SMP Coax Adapter with Cables
P76TA	P7500 Series Solder Tip Adapter ²
P76CA-BTI292	P7600 Custom Tip Interface Coax Adapter ¹

¹ Requires a matched-pair coaxial cable set
² Requires a P7500 Series TriMode solder tip

Accessories

All of the adapters include these instructions and a 2 mm hex wrench for securing the adapter to the probe head. The P76TA adapter also includes a kit of solder ramps to help minimize the solder tip lead lengths for best performance.

Description

The coax adapters are designed to complete the connection from Tektronix P7600 Series probes to SMP and SMA connectors on your circuit. The coax adapters support full TriMode capability (differential, single-ended, and common-mode configurations).

Use the P76CA-292 Coax Adapter with high bandwidth, low skew (<2 ps) cable pairs. The

Using the Adapters

The probe and probe adapters are extremely sensitive to electrostatic discharge (ESD). Always work at an ESD-approved workstation or in an ESD-approved environment.

Secure mechanical connections are necessary to ensure the best signal integrity between the adapters, the probe and the circuit under test. Therefore, always observe the best practices listed below for the best performance.

- Use the 2 mm hex wrench included with the adapters to tighten the screw on the adapter housing to the probe head.
- After you hand-tighten the coax connectors to your circuit, use two wrenches to secure each connector: One on the middle cable nut to minimize cable twist, and a torque wrench on the connector.
- When you tighten cable connectors that are close to each other (as on the P76CA-292 adapter), be careful not to strike adjacent connectors with the wrench.
- To preserve the adapter cables and maintain the highest signal fidelity, never kink the wires or put undue stress on them.
- Secure the probe and probe adapter to the circuit or chassis to prevent excessive strain on the connections. For example, do not

CAUTION. To prevent over-torquing the screw, only insert the long end of the wrench into the screw. The probe head can be damaged by over-torquing the screw.

Coax Adapters

To prevent damage and prolong connector and cable life, the cable and center conductors must not twist when making connections.

CAUTION. Always use a wrench to minimize the cable twist when you connect and disconnect the 2.92 mm adapters and cables. Use a torque wrench to tighten the connectors to 8 in-lbs. Failure to do so will shorten the service life of the adapters.

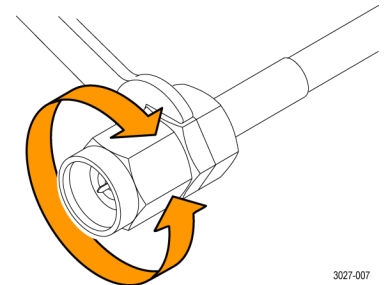

Coaxial cables can store a static charge when they are not connected to equipment or circuitry, so you should briefly short the center conductor of the cable to the outer conductor before

connecting the cable to the adapters or your circuit.

P7500 Series Solder Tips

1. Choose a location where the solder tip can reach your test points, while keeping the tip leads as short as possible (<0.032 in./0.8 mm). The solder ramps included with the P76TA adapter help to achieve this, as shown in the photo below. Note signal polarities and grounds where applicable.

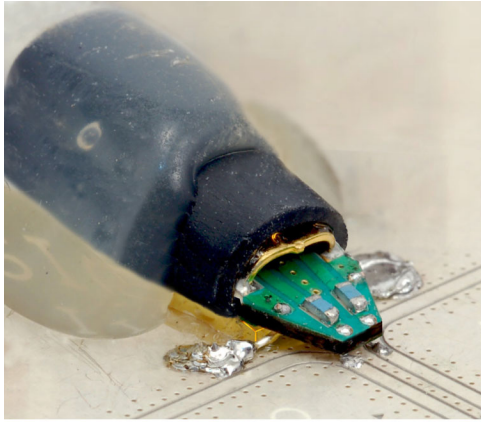

2. Apply solder to the test points on your circuit, and then solder wires to the test points. Use 4 to 8 mil wire for best results. A wire kit that also includes lead-free solder is available; see *Optional Accessories*.
3. Attach the solder ramp to the tip: Align the bottom of the tip to the notch in the ramp as shown, and then secure the tip to the ramp with glue or tape. The notch in the ramp helps you to position the tip as close as possible to the circuit connections.

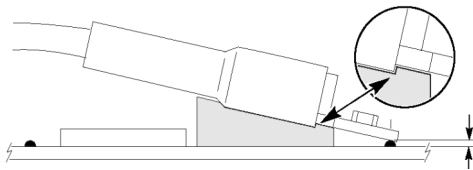

4. Slide the tip over the soldered wires on your circuit and solder the wires to the tip. Clip off any excess wires.
5. Secure the tip to your circuit with tape or hot glue.
6. Align the solder tip cable with the red band to the red A input of the probe adapter. Push the cable into the probe adapter until it seats in the adapter.
7. For a secure mechanical connection, use tape or hot glue to secure the adapter and probe head to your circuit.

Dimensions

Probe head (reference)

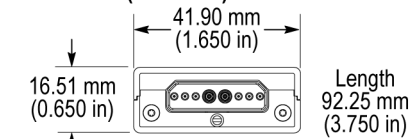

P76CA-292

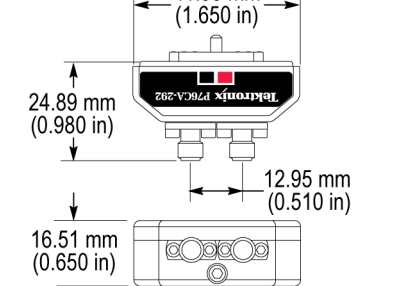

P76CA-292C

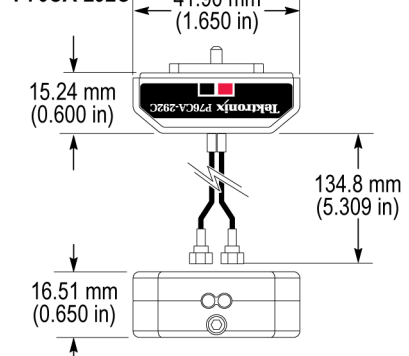

P76CA-SMP

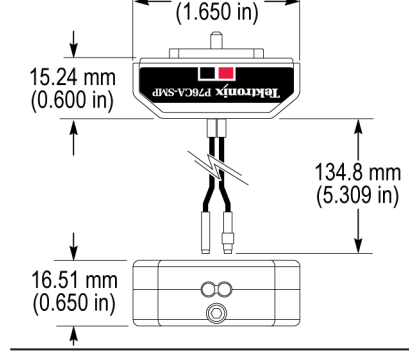

P76TA

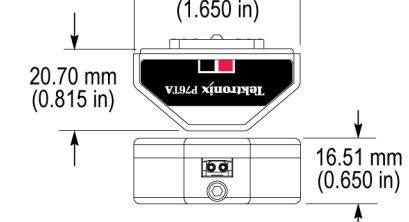

P76CA-BTI292

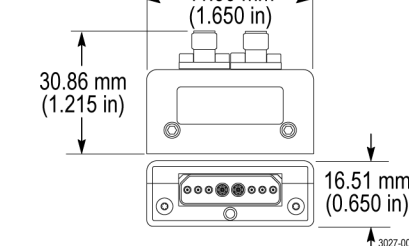

Electrical Characteristics (Typical)

The specifications in the table below apply to the P7633 probe when used with a MSO/DPO73304D/DX oscilloscope.

P7600 Series TriMode Coax Adapters

	P76CA-292	P76CA-292C	P76CA-SMP
Bandwidth	33 GHz	33 GHz	33 GHz
Rise time ¹			
10–90%	14 ps	14 ps	14 ps
20–80%	11 ps	11 ps	11 ps

¹ Temperature range +18 °C to +28 °C (64 °F to 82 °F)

P76TA Adapter + P75PST Tip + P7633/P7630 Probe or P76CA-BTI292 Adapter

Bandwidth	30 GHz
Rise time, 10–90%	16 ps
Rise time, 20–80%	12 ps

Optional Accessories

The following accessories are available for the adapters and tips.

30 GHz Performance Solder Tip	P75PST
20 GHz TriMode Solder Tip	P75TLRST
P7500 Series TriMode Solder Tip solder ramps (kit of 25)	020-3118-xx
Replacement wire kit (includes one roll each of: 4 mil wire, 8 mil wire, SAC305 lead-free solder)	020-2754-xx
Phase-matched SMA cables (38 in.)	174-5771-xx
Adapter wrench, 2 mm (1 each)	129-2781-xx



Equipment Recycling. This product complies with the European Union's requirements according to Directive 2002/96/EC on waste electrical and electronic equipment (WEEE). For more information about recycling options, check the Support/Service section of the Tektronix Web site (www.tektronix.com).

Warranty Information

For warranty information, go to www.tektronix.com/warranty.

Contacting Tektronix

Tektronix, Inc.
14200 SW Karl Braun Drive
PO Box 500
Beaverton, OR 97077
USA

For product information, sales, service, and technical support:

- In North America, call 1-800-833-9200.
- Worldwide, visit www.tektronix.com to find contacts in your area.